

INCH-POUND

MIL-DTL-24784/7B (SH)

15 February 2002

SUPERSEDING

MIL-DTL-24784/7A(SH)

15 March 1999

ASSOCIATED DETAIL SPECIFICATION

TECHNICAL REPAIR STANDARDS (TRS) FOR HULL, MECHANICAL, AND ELECTRICAL (HM&E) EQUIPMENT, ELECTRONIC EQUIPMENT, AND ORDNANCE EQUIPMENT

This specification is approved for use by the Naval Sea Systems Command, Department of the Navy, and is available for use by all Departments and Agencies of the Department of Defense.

1. SCOPE

1.1 Scope. This specification sets forth the content requirements and instructions for the development of technical repair standards (TRSs) for use in performing class B overhauls to hull, mechanical, and electrical (HM&E) equipment and components, electrical equipment and components, and ordnance equipment and components (see 6.2).

2. APPLICABLE DOCUMENTS

2.1 General. The documents listed in this section are specified in sections 3 and 4 of this specification. This section does not include documents cited in other sections of this specification or recommended for additional information or as examples. While every effort has been made to ensure the completeness of this list, document users are cautioned that they must meet all specified requirements documents cited in sections 3 and 4 of this specification, whether or not they are listed.

2.2 Government documents.

2.2.1 Specifications, standards, and handbooks. The following specifications, standards, and handbooks form a part of this document to the extent specified herein. Unless otherwise specified, the issues of these documents are those listed in the issue of the Department of Defense

Beneficial comments (recommendations, additions, deletions) and any pertinent data which may be of use in improving this document should be addressed to: Commander, Naval Sea Systems Command, ATTN SEA 05Q, 1333 Isaac Hull Ave SE Stop 5160, Washington Navy Yard DC 20376-5160 by using the Standardization Document Improvement Proposal (DD Form 1426) appearing at the end of this document or by letter.

AMSC N/A

AREA TMSS

DISTRIBUTION STATEMENT A. Approved for public release; distribution is unlimited.

MIL-DTL-24784/7B(SH)

Index of Specifications and Standards (DoDISS) and supplement thereto, cited in the solicitation (see 6.2).

SPECIFICATIONS

DEPARTMENT OF DEFENSE

- | | |
|---------------|---|
| MIL-DTL-24784 | Manuals, Technical: General Acquisition and Development Requirements. |
| MIL-PRF-28800 | Test Equipment for Use with Electrical and Electronic Equipment, General Specification for. |

HANDBOOKS

DEPARTMENT OF DEFENSE

- | | |
|--------------|--|
| MIL-HDBK-61 | Configuration Management Guidance. |
| MIL-HDBK-267 | Guide for Selection of Lubricants and Hydraulic Fluids for Use in Shipboard Equipment. |

(Unless otherwise indicated, copies of the above specifications, standards, and handbooks are available from the Standardization Documents Order Desk, 700 Robbins Avenue, Building. 4D, Philadelphia, PA 19111-5094.)

2.3 Non-Government publications. The following document(s) form a part of this document to the extent specified herein. Unless otherwise specified, the issues of the documents which are DoD adopted are those listed in the issue of the DoDISS cited in the solicitation. Unless otherwise specified, the issues of documents not listed in the DoDISS are the issues of the documents cited in the solicitation (see 6.2).

INTERNATIONAL STANDARDS ORGANIZATION (ISO)

- | | |
|-------------|--|
| ISO 14644-1 | Cleanrooms and Associated Controlled Environments- Part 1: Classification of Air Cleanliness. |
| ISO 14644-2 | Cleanrooms and Associated Controlled Environments- Part 2: Specifications for testing and Monitoring to Prove Continued Compliance with ISO 14644-1. |

(Application for copies should be addressed to the American National Standards Institute, 11 West 42nd Street, New York, NY 10036)

2.4 Order of precedence. In the event of a conflict between the text of this document and the references cited herein (except for related associated detail specifications), the text of this document takes precedence. Nothing in this document, however, supersedes applicable laws and regulations unless a specific exemption has been obtained.

MIL-DTL-24784/7B(SH)

3. REQUIREMENTS

3.1 General. The requirements for acquiring the product described herein shall consist of this document and MIL-DTL-24784.

3.2 Security classifications, distribution statement and destruction notice. The security classification, distribution statement and destruction notice shall be in accordance with MIL-DTL-24784.

3.3 Deliverable products and data items. Deliverable products and data items shall be in accordance with MIL-DTL-24784 (see 6.2) and as follows:

3.3.1 Engineering Judgment Records (EJR). If required by the technical manual contract requirements (TMCR) (see 6.2), EJRs shall accompany HM&E and ordnance TRSs submitted, but shall not form a part of the TRS. The EJR shall contain the engineering analysis and reasoning in support of all deviations to tolerances, limits, and other parameters included in the TRS. Each deviation shall be identified with the associated paragraph numbers of the TRS. If deviations from specification requirements are necessary, requests for deviation shall be submitted together with a separate engineering analysis.

- a. First Time Acquisitions. Concurrent with the first acquisition of a new system, equipment or component design, a concise formal EJR shall be developed for each data entry.
- b. Re-acquisitions. For a complete TRS or TRS change pages developed for existing equipment or systems, a formal EJR is not required for each data entry.
- c. Deviations. When changes or deviations from existing documents are proposed with regard to clearances, tolerances, materials, procedures, or the implementation of new procedures, worksheets justifying the change or deviation shall be submitted for approval.

3.3.2 Cost and pricing data. Cost and pricing data, if specified in the TMCR, shall be in accordance with MIL-DTL-24784 (see 6.2).

3.4 Arrangement. Unless otherwise specified in the TMCR (see 6.2), the manual shall be arranged in a standardized format that is, front matter, technical content, appendices, glossaries, indices and Technical Manual Deficiency/Evaluation Report (TMDER) and appropriately divided by volume, part, chapter and section in accordance with the requirements of MIL-DTL-24784 and the following.

3.4.1 TRS subject matter. The TRS shall provide detailed instructions for performing a class B overhaul. The TRS shall discuss critical procedures (see 6.4.3), testing and maintenance examinations, supporting illustrations, lists of items to be replaced and any special tools needed for the overhaul. The TRS shall also describe critical operations and checks that must be done during item reassembly, minimum quality control requirements, and specific post-overhaul inspections. The technical content for systems and equipment shall be formatted to meet HM&E

MIL-DTL-24784/7B(SH)

requirements (see 3.6) or electronics requirements (see 3.7) or ordnance requirements (see 3.8) as applicable (see 6.2). The TRS sequence and breakdown of divisions shall be as follows:

- a. The technical content shall follow the front matter and shall be arranged in chapters. Each chapter shall consist of one or more sections that are divided into main paragraphs, and then subdivided into subparagraphs. Each section and major (numbered) paragraph shall have a brief title describing the content or action required. The level of detail shall be geared to the journeyman-level mechanic.
- b. Technical content for a compound (composite) item, with major subassemblies (see 6.4.7), shall be divided so that each major item will be addressed in a separate chapter to promote the work-unit, work-package concept (see 6.4.8).
- c. Minor assemblies shall be divided into separate sections and included with their major subassemblies, to promote work group breakdown structure of authorized overhaul facilities.

3.4.2 Multipart volumes. The TRS shall be divided into two parts. Part 1 shall contain all overhaul procedures, requirements, and drawings necessary to perform the overhaul. Part 2 shall record all readings specified in Part 1.

3.5 Format and development instructions. Unless otherwise specified in the TMCR (see 6.2), the writing style, safety precautions, tabular material, graphics, and numbering shall be in accordance with MIL-DTL-24784.

3.6 HM&E TRS technical content. The TRS shall be developed as a two-volume package. HM&E TRS technical data shall be formatted as follows.

- a. Part one of the volume shall contain:
 1. Front matter (see MIL-DTL-24784).
 2. Chapter 1 - General information (see 3.6.1).
 3. Chapter 2 - Shipboard removal (and replacement) (see 3.6.2).
 4. Chapter 3 - Unit disassembly (see 3.6.3).
 5. Chapters 4 through "n" - Item overhaul procedures for each major component and assembly with a separate chapter for each component (pump, turbine) and major assembly (see 6.4.2) (governor, governor valve and servomotor, attached oil pump, motor driven oil pump) shall be provided. Each chapter shall discuss disassembly, inspection, repair, reassembly, testing, and so forth (see 3.6.4).
 6. Chapter n + 1 - Unit assembly (see 3.6.5).
 7. Chapter n + 2 - Unit shop test (see 3.6.6).
 8. Chapter n + 3 - Shipboard installation, alignment, and testing (see 3.6.7).
 9. Appendix A - Mandatory overhaul replacement parts list (see 3.6.8.1).
 10. Appendix B - Contingency material list (see 3.6.8.2).
 11. Technical manual deficiency/evaluation report (TMDER)/User activity technical manual comment sheet (UATMCS) (see MIL-DTL-24784).
- b. Part two of the volume shall contain:

MIL-DTL-24784/7B(SH)

1. Front matter that describes content and instructions for collecting and disposing of the data package (see MIL-DTL-24784).
2. Material condition/overhaul report (MC/OR) (see 3.6.8.3).
3. Appendix C - examination, test, and repair action record (ETRAR) (see 3.6.8.4).
4. Additional appendices (D and on) - special requirements (see 3.6.8.5).
5. TMDERs (see MIL-DTL-24784).

3.6.1 Chapter 1 - General information. This chapter shall provide a general overview of the data presented in the TRS. The chapter shall include the following information and identify with numbered paragraph headings as applicable.

3.6.1.1 Scope. The scope shall include a brief summary of the purpose, content, and arrangement of the TRS, including appendices. It shall also state that all commercial and Government activities involved in the overhaul process must meet all TRS class B overhaul requirements.

3.6.1.2 Points of contact. This paragraph shall state that the TRS takes precedence over all other technical documents for overhaul of the commodity. It shall further state that the shop supervisor or design division should be contacted regarding problems associated with use of the TRS.

3.6.1.3 Overhaul conformance. This paragraph shall state that compliance with the applicable chapters of the TRS is mandatory and that, upon completion of the overhaul, equipment must meet the stated performance specifications. This paragraph shall also contain the following information:

- a. Specify that configuration changes are not authorized without Government approval.
- b. Address visual inspection requirements of replacement parts and specify that the TRS does not require replacement part testing.
- c. State that parts listed in the mandatory overhaul replacement parts list (Appendix A) (see 3.6.8.1) are included because of high past failure rates and/or cost to repair or replace and that these parts shall be replaced regardless of condition. Therefore, this material shall be on hand prior to performing a class B overhaul in accordance with the TRS.
- d. Specify that the contingency material list (Appendix B) (see 3.6.8.2) contains a list of those parts that may need to be replaced during the overhaul. The decision to buy these contingency parts shall be made by the overhauling activity.
- e. Direct the TRS user to record specified readings test results, inspection and examination results, as well as corrective actions; and forward this data to the TRS maintenance activity.
- f. Specify that data readings are recorded at certain inspection and verification (I&V) (see 6.4.5) points during the overhaul. An individual shall be chosen to sign off on all mandatory I&V points. The local overhauling activity may designate additional I&V points if needed.

3.6.1.4 Documentation and references. A tabular listing shall be developed to present all documents, publications, product engineering drawings and schematics, specifications and stand-

MIL-DTL-24784/7B(SH)

ards, engineering change data, and other reference data used in the development of the TRS and referenced in the text. Applicable documents shall be listed in the order they are referenced in the text.

3.6.1.5 Unit assembly and subassembly. This paragraph shall identify the repairable items (see 6.4.6) covered by the TRS. Items shall be identified by nomenclature, model number, allowance parts list (APL), Commercial and Government Entity (CAGE) code, and manufacturer's part number. These data shall be listed in tabular form. This paragraph shall also provide a tabular list of the ship or machinery alterations which have been incorporated into the TRS and the hull numbers to which they apply. If no ship or machinery alterations have been incorporated into the TRS, a statement to that effect shall be included.

3.6.1.6 Parts replacement. Subparagraphs in this topic area shall be developed to specify that:

- a. The local manufacture or fabrication of certain parts is strictly forbidden. Because of the critical nature and stringent manufacturing requirements, the Government has restricted the manufacture of these parts to qualified sources. A tabular listing of all such parts shall be provided. The list shall contain the restricted part by name and part number. In addition, these parts shall be highlighted by an appropriate note in Appendices A or B (see 3.6.8.1 and 3.6.8.2), as applicable. A printout of those parts which have been restricted may be obtained from the Government activity providing supply support for the commodity.
- b. Parts examined which do not meet acceptance criteria may be repaired [if not on Appendix A (see 3.6.8.1) or a restricted part] or shall be turned in to the supply system or disposed of using current procedures and documentation. Local manufacture of nonrestricted parts may be accomplished when acquisition is delayed; however, these parts shall conform to drawing specifications and source inspections.
- c. Shop store items such as gaskets and packing material, locknuts and lockwashers, cotter pins, keys, and so forth, are not listed in the mandatory overhaul replacement parts list or contingency material list but shall be replaced. This material shall be on hand to accomplish the planned overhaul maintenance.

3.6.1.7 Special facilities, test equipment, skills, and test conditions. This paragraph shall note the special or unusual equipment, facilities, or personnel skills required to accomplish the TRS equipment overhaul. It shall include the following information as required:

- a. The special facilities required to perform the overhaul shall be identified as prescribed and listed in tabular form.
- b. Special test equipment (or acceptable alternative items) and repair aids required (specify quantities) in the examination, repair (including alignment, adjustment, and troubleshooting), and performance or acceptance testing of the items covered by the TRS, shall be identified and described. A tabular listing is preferred.
- c. Skills requiring special training shall be defined. This information shall be presented in a brief narrative form or a tabular listing.

MIL-DTL-24784/7B(SH)

- d. Special work station environmental conditions required in the overhaul process shall be specified: atmospheric pressure, specific temperatures, relative humidity, or clean rooms. This information may be appropriately detailed in table format.

3.6.2 Chapter 2 - Shipboard removal (and replacement). This chapter shall include procedural, inspection, repair, data recording, and testing information with supporting appendices, warning and caution statements, and sketches in accordance with applicable TRS requirements:

- a. Unit boundary identification (addressing overhaul considerations for complete or partial unit overhaul/removal).
- b. Draining unit.
- c. Insulation removal (with appropriate asbestos hazard warnings).
- d. Interference, interface, and piping removal (with appropriate asbestos hazard warnings).
- e. Unit installation site (foundation, interface, and so forth).
 - 1. Preparation.
 - 2. Cleaning.
 - 3. Inspection.
 - 4. Repair.
 - 5. Blanking-off, tagging, and so forth (including applicable tag out requirements).
 - 6. Removal (and replacement) routes (where specific routes have been developed, they shall be included or referenced as required).

3.6.3 Chapter 3 - Unit disassembly. This chapter of the TRS shall specify the requirements for disassembly of the major components of the unit to facilitate the work breakdown structure of a compound unit, as broken down into repair sections in Chapters 4 through "n", as required. Procedural and data recording requirements with supporting appendix pages, warning and caution statements, and sketches in accordance with the applicable requirements shall be provided for the following:

- a. Major unit boundary identification.
- b. Coupling separation/interface and piping removal, electrical disconnection.
- c. Major unit removal.

3.6.4 Chapter 4 through "n" (and others as required) - Item overhaul procedures.

These chapters shall contain procedures, minimum test and inspection requirements, processes, methods, and data deemed necessary for the satisfactory accomplishment of a class B overhaul. Acceptance or rejection criteria for wear, deterioration, dimensions, operating parameters, alignment, and other standards of acceptance shall be specified with limits listed in the text and in Appendix C (see 3.6.8.4). Each component or major assembly shall be defined in a separate chapter. The chapters and the sections within each chapter shall be arranged in a top-down logical sequence of disassembly, repair, and assembly. Each chapter shall contain the following sections:

- a. Removal, disassembly, inspection, and repair procedures.

MIL-DTL-24784/7B(SH)

- b. Examination and acceptance criteria, corrective action, mandatory replacement parts, cleaning methods, and data collection.
- c. Reassembly procedures.
- d. Acceptance testing (if applicable). Subsections will usually discuss subassemblies or individual parts (may be more than one related part per subsection).

3.6.4.1 Removal, disassembly, inspection, and repair procedures. Step-by-step procedures for the disassembly, repair, and inspection of the repairable items shall be developed. Detailed instructions shall be limited to areas where the sequence of operations is not obvious or where special techniques are required for access to a part requiring repair. When the sequence of disassembly is obvious, it is sufficient to state "Disassemble by removing parts in accordance with the disassembly sequence numbers." Additional instructions, cautions, and warnings should be specified in sequence with a disassembly instruction as required. Instructions on the tagging, labeling, and match-marking of parts shall be included in this paragraph. When examinations and inspections must be performed prior to or during disassembly, the TRS shall so specify. Step-by-step procedures shall be provided in any of the following cases (see MIL-DTL-24784):

- a. When accomplishment of the required action would not be obvious to a journeyman mechanic unfamiliar with the particular equipment covered by the TRS.
- b. When a peculiar or special action is required.
- c. When safety related or precautionary procedures are required to prevent personnel injury or equipment damage.
- d. When the required action involves an area with a known history of failure due to improper procedures.
- e. When because of the complexity of a particular procedure it is necessary to maintain the continuity of the TRS.

3.6.4.2 Mandatory replacement parts. When the requirement exists for the planned mandatory replacement of particular items, the TRS shall reference the mandatory overhaul replacement parts list (see figure 7-1), (see 6.2). The list shall be in tabular format, in Appendix A, and shall identify those parts that are required to be replaced, regardless of their condition. Replacement materials shall be available at the overhaul activity in accordance with their TRS instructions. Examples of mandatory replacement items may be parts such as seals, washers, vacuum tubes, air filters, and motor brushes.

3.6.4.3 Examination criteria Criteria to determine the suitability of worn or degraded critical parts for continued use shall be developed and shall explicitly state the measurable wear and deterioration limits which, if exceeded, would require corrective action to maintain reliability and specified performance. These data shall appear in the text and be presented, in tabular form, in Appendix C (see 3.6.8.4). Data shall identify the part and measurable limits. Departures from existing limits shall be highlighted with a text footnote. Corrective actions shall also be specified in the text.

3.6.4.4 Special cleaning methods When applicable to the repairable items covered in the TRS,

MIL-DTL-24784/7B(SH)

special processes and methods of cleaning and examination to be performed on each disassembled item shall be described. Special cleaning and inspection instructions shall include:

- a. The pre-cleaning examination requirements and cleaning process to be used for each item requiring cleaning.
- b. Step-by-step procedures for accomplishing the cleaning process.
- c. Specific identification of cleaning materials to be used by their commonly known name and specification number. These data may be provided in tabular format.
- d. Quantitative instructions for the variables associated with the cleaning process; for example: air pressure, moisture content, solvent temperature, soak time, ultrasonic frequency, drying time, and temperature.
- e. Procedures for use of special tools, jigs, or fixtures.
- f. Post-cleaning examination, preservation, and handling instructions.
- g. Cautions or warnings to be observed to protect personnel and equipment.
- h. Other data as may be determined appropriate for the repairable items.

3.6.4.5 Inspection, data collection, and corrective actions. Procedures, special instructions, examination, and technical information (including supplementary illustrations and tabular lists) required to perform effective inspection and repair of the repairable items covered in the TRS shall be identified (see 6.2). The actions to be performed shall ensure that the repairable items meet or exceed the specified performance requirements of the final acceptance test (FAT) (see 6.4.4) and satisfies all quality assurance inspection requirements.

3.6.4.5.1 Fault identification. Detailed step-by-step procedures for identifying problems shall be developed.

3.6.4.5.2 Corrective action. Detailed step-by-step procedures for corrective actions, including the repair and replacement of defective, damaged, or deteriorated parts, shall be developed.

3.6.4.5.3 I & V. I&V points shall be noted in the TRS left-hand margin by "I" or "V", both in the text and Appendix C. I&V points shall be determined by using the best engineering judgment. All data to be collected shall be specified in the text. The requirement to sign all I&V points shall be included in the front matter of parts 1 and 2 of the TRS. Signature blocks shall be provided as appropriate in the ETRAR (see 3.6.8.4).

3.6.4.5.4 Alignment and adjustment procedures. Detailed procedures shall be identified or developed for sophisticated mechanical and electrical alignments and adjustments. Procedures shall describe the methods used and special tools and equipment required to achieve the setting and positioning of adjustments and controls, and mechanical, gearing, and linkage alignments within the repairable item.

3.6.4.6 Reassembly. Illustrations, reassembly instructions, and examination requirements for the reassembly of the repairable items shall be developed as required. The use of any special tools, jigs, fixtures, or test equipment shall be specified. Where sequence of reassembly is obvious, it is sufficient to state "Reassemble by installing parts in accordance with the reassembly sequence

MIL-DTL-24784/7B(SH)

numbers". Additional instructions, cautions, warnings, and dangers shall be specified in sequence within a reassembly instruction when required. Figures prepared to support disassembly instructions may be repeated; however, sequence numbers shall be changed to reflect proper numerical order for reassembly. The instructions or procedures shall indicate the following:

- a. The use of corrosion-preventive compounds, paints, or other materials and the use of gaskets or sealing compound materials shall be specified by nomenclature, trade name, specification number, and national stock number (NSN). Non-NSN consumables and materials shall be avoided whenever possible.
- b. Identification of all points requiring lubrication, the kind of lubricants required, and the method of application. Lubricants to be used shall be those specified in the standard lubricants lists. A NSN shall be listed if available. Additional information regarding lubrication can be found in MIL-HDBK-267.
- c. Any special instructions for installing fasteners, safety wiring, cotter pins, and other locking devices.
- d. Special instructions for aligning, adjusting, and measuring tolerances, clearances, end play, backlash, and tolerances between gears and linkage alignment data.
- e. Identification of critical examinations and tests during reassembly and, if required, provisions for data collection.
- f. Reference to tables, appendices, or illustrations as applicable.
- g. Other data as may be determined appropriate for the repairable items type.

3.6.4.7 Acceptance test. Acceptance testing shall be specified for each individual component, if needed, and for the system as a whole. The section shall specify that:

- a. After completing all repair or overhaul actions and when the repairable item is considered ready for final examination, the item shall be inspected for proper identification and tested to verify satisfactory performance.
- b. The acceptance test (see 6.4.1) shall be accomplished in accordance with the established performance requirements. Reference shall be made to pertinent data contained elsewhere in the TRS.
- c. Specified data collection requirements for the item shall be included in the TRS ETRAR (see 3.6.8.4).

3.6.5 Chapter n + 1 (or as applicable) - Unit assembly. This chapter shall specify all criteria addressed in Chapter 3 as applicable to unit reassembly. The following items shall be covered:

- a. Major unit installation.
- b. Piping, interface installation and alignment.
- c. Coupling cold alignment.

3.6.6 Chapter n + 2 (or as applicable) - Unit shop test. This chapter shall be developed to facilitate work breakout for a complete unit that requires a unit shop test prior to shipboard installation. An approved outline for the generic unit shall be used in determining the following unit test requirements:

MIL-DTL-24784/7B(SH)

- a. Test stand requirements.
- b. Unit flush.
- c. Unit shop test requirements.

3.6.7 Chapter n + 3 (or as applicable) - Shipboard installation, alignment, and testing.

This chapter shall specify requirements for:

- a. Unit installation.
- b. Insulation installation.
- c. Cold alignment recheck.
- d. Piping, interface installation and alignment.
- e. System check.
- f. Coupling hot alignment.
- g. Unit break-in.
- h. FAT.
- i. Interfacing system inspection.

3.6.8 Appendices. The TRS shall provide pertinent supplementary and reference data required in the inspection, parts replacement, testing, and final acceptance of the repairable items covered in the TRS. Each appendix shall contain a statement delineating its purpose and application. Appendices shall be in accordance with MIL-DTL-24784.

3.6.8.1 Appendix A - Mandatory overhaul replacement parts list. This appendix shall contain a comprehensive list of items which shall be replaced, regardless of observed condition (see 3.6.4.2). There shall be a separate sheet listing the mandatory replacement parts for each unit subassembly or major subassembly component. It shall be a tabular listing of parts similar to figure 7-1. The parts designated for the mandatory overhaul replacement parts list shall be specified by the Government acquisition activity using the following considerations:

- a. Parts which are usually damaged or destroyed during equipment disassembly.
- b. Parts normally subject to accelerated wear.
- c. Parts known to be more economical to replace than inspect.
- d. Parts which have a history of high usage.
- e. Parts that have a high documented failure rate and are costly to replace between overhauls.
No direct or indirect citation of the actual failure rate of any part is allowed. Technical manuals shall not list or cite any figures of merit for the reliability or maintainability of the equipment (or parts) at any level of indenture.

All TRS written requirements shall be met before a class B overhaul will be certified as complete. If a material ordering guide (MOG) exists for an item being covered in the TRS, the MOG may be used to develop appendix A.

3.6.8.2 Appendix B - Contingency material list. A contingency material list shall be developed. It shall be a tabular listing of parts, similar to figure 7-2. When developed, there shall be a

MIL-DTL-24784/7B(SH)

separate sheet for each unit subassembly or major subassembly or component. The contingency material list is a guide for material that may be needed when the unit is overhauled. It shall list the parts which may require replacement during the overhaul of the unit. Any part listed in the contingency material list shall be addressed in the appropriate inspection and repair subsection of the TRS. Those parts whose costs approach or exceed the total cost of the unit shall not be listed. Parts which rarely require replacement and are not normally replacement parts for unit overhaul shall not be listed. A MOG, if it exists, may be used to develop Appendix B.

3.6.8.3 MC/OR. A certification document shall state that the overhaul has been properly completed and meets all means specified in the acceptance criteria. It will also provide a means to collect additional information from the line mechanic concerning conditions observed prior to, and during, the overhaul. Directions for recording data and distribution of the report shall be specified in the TRS text. A typical MC/OR is shown in figure 7-3. At a minimum, MC/ORs shall conform to the following:

- a. Check-the-box and short fill-in questions shall be used to the greatest degree possible.
- b. A heading identifying the component shall be completed.
- c. Specific questions regarding the "as found" material condition of the item shall be prepared.
- d. Provision shall be made for the mechanic to supply informal comments and short remarks.
- e. Specific questions or statements regarding the "as overhauled" state of the item shall be prepared.
- f. Provision shall be made for the mechanic to record or highlight any approved or unapproved deviations and out-of-spec data.
- g. A separate MC/OR shall be prepared for each subassembly and major subassembly component and shall be included in the appropriate data section in part 2.
- h. MC/ORs shall be identified in the table of contents, list of effective pages, and TRS text.

3.6.8.4 Appendix C (part 2) - ETRAR. Required ETRAR information (see figure 7-4) shall include the system test step number and the desired response and tolerance limits. Other information may vary according to the equipment type or user requirements. Separate summary sheets shall be developed for each subassembly and major subassembly or component as previously specified in the TRS and assigned an appropriate title. Each instruction to record data in the TRS text shall also be entered in the ETRAR. When possible, a line drawing identifying the measurement to be taken shall be provided on the same page. Reading specifications or parameters that depart from original design characteristics shall be highlighted and footnoted with rationale. A space for signatures at specified data entry and I & V points shall also be provided. The last section of Appendix C for each major subassembly component and the last section of the total unit shop test and unit FAT shall specify the minimum criteria for determining whether the class B overhaul requirements are in accordance with Government testing criteria. No space for recording data on these pages shall be provided. However, activities shall be directed to submit all local shipyard test forms with the completed overhaul record (part 2 of the TRS).

3.6.8.5 Additional appendices (D and on). When specified in the TMCR (see 6.2), the text in the body of the TRS shall specify any other special requirements covered, with additional appendices.

MIL-DTL-24784/7B(SH)

3.7 Electronic equipment TRS technical content. The sequence of electronic equipment TRSs technical data shall conform to the following:

- a. Front matter (see MIL-DTL-24784).
- b. Chapter 1 - General information (see 3.7.1).
- c. Chapter 2 - Facilities, test equipment, personnel, and test conditions (see 3.7.2).
- d. Chapter 3 - Inspection methods (see 3.7.3).
- e. Chapter 4 - Performance test procedure (see 3.7.4).
- f. Chapter 5 - Overhaul procedure and FAT (see 3.7.5).
- g. Chapter 6 - Packaging, handling, storage, and transportation (PHST) (see 3.7.6).
- h. Appendix A - Repairable item data (see 3.7.7.1).
- i. Appendix B - Test support equipment data (see 3.7.7.2).
- j. Appendix C - Test data record sheets (see 3.7.7.3).
- k. Additional appendices (D - G) - Other appendices or enclosures (as required) (see 3.7.7.4).
- l. TMDERs/UATMCSs (see MIL-DTL-24784).

3.7.1 Chapter 1 - General information. This chapter shall state the purpose, organization, and intended use of the TRS. This section shall include the following information.

3.7.1.1 Frontispiece illustration. The front matter shall include pictorial representation of the repairable items (see 6.4.6) covered in the TRS shall be placed on the left-hand page preceding Chapter 1 (see MIL-DTL-24784).

3.7.1.2 Production process. This chapter shall include production process flow charts or work flow block diagrams (see MIL-DTL-24784) graphically depicting the required sequence of repair/overhaul events during the maintenance process described in the TRS. These displays may consist of block diagrams depicting the entire process with more detailed flow charts showing specific phases of the repair/overhaul process. Sufficient detail shall be provided to clearly illustrate the described process.

3.7.1.3 Scope. The scope shall:

- a. Include a brief summary of the technical content of the TRS including all appendices. It shall include statements that:
 1. Conformance with the TRS is required of designated commercial and Government activities authorized to conduct the class B overhaul of the items covered in the TRS.
 2. Ensure that component configuration changes are not authorized unless previously approved by the life cycle manager (LCM).
 3. The TRS reflects the latest (state the date) approved configuration and technical documentation (see MIL-HDBK-61).
- b. Identify the repairable items (see 6.4.6) covered by the TRS using approved nomenclature, NSN, APLs, and all applicable commercial items and items with CAGE code and part

MIL-DTL-24784/7B(SH)

numbers. It shall also identify the next higher assembly, equipment, and system in which the repairable item is used. These data shall be listed in tabular form.

- c. In cases where the TRS specifically pertains to a repairable end item containing a repairable subassembly, it shall contain statements that:
 1. Identify the subassembly in the same fashion as item (b) above and the applicable subassembly TRS document number.
 2. Briefly state the relationship of the subassembly to the repairable end item.
 3. Provide the data in tabular form.
- d. Provide a tabular list of ship alterations (SHIPALTs), field changes, engineering changes, etc., that have been incorporated into the TRS.
- e. Provide a point of contact for answering questions which may arise during overhaul/repair concerning configuration or SHIPALTs in accordance with the requirements of the acquisition activity (see MIL-HDBK-61).

3.7.1.4 Item description. A tabular listing of the overall dimensions, approximate weight, and approximate volume of the repairable items covered by the TRS shall be determined. Overall dimensions shall be the height, width, and depth in inches; approximate weight shall be the total weight in pounds and ounces; and approximate volume shall be the total volume in cubic feet and inches for the uncrated repairable items, with appropriate metric conversions, if required.

3.7.1.5 Documentation. A tabular listing of all publications, product engineering drawings and schematics, specifications and standards, engineering and field changes data, and other reference data used in the development of the TRS shall be presented. Applicable documents shall be listed in the order they are referenced in the text.

3.7.1.6 Deviations and waivers. A statement shall be provided that waivers and deviations for minor material or performance characteristics may be approved at the local level only with Government approval. Major design or logistic deviation and waiver request will be approved in writing by the Government. Parts, clearances, or conditions for which specified requirements cannot be met require compliance with MIL-HDBK-61, execution of Form 1694 for deviations and waivers, and approval for a departure from specification.

3.7.2 Chapter 2 - Facilities, test equipment, personnel, and test conditions. This chapter shall state the requirements for the facilities, equipments, and overhaul personnel required to accomplish effective, efficient refurbishment of the items covered by the TRS. This section shall consist of the following information.

3.7.2.1 Facilities. The facilities required (specify quantities) for the repair process shall be identified and described. The following information shall be normally listed in a tabular form:

- a. Work area, space, and storage requirements.
- b. Shop machine, handling, and support equipment requirements (common and special).
- c. Electrical power and ground requirements.

MIL-DTL-24784/7B(SH)

- d. Hazard or safety and security requirements.
- e. Electromagnetic interference and compatibility requirements.
- f. Forced ventilation or air changes required from the facility.
- g. Service requirements; for example, water, gas, hydraulic oil, and so forth (specify required pressures and flow rates).
- h. Other facility requirements as determined.

3.7.2.2 Test equipment. A tabular listing shall be developed and shall describe all test equipment and repair aids required (specify quantities) in the examination, repair (including alignment, adjustment, and troubleshooting), and performance or acceptance testing of the repairable items covered by the TRS. These data shall be provided in the form shown on figure 7-5.

- a. General purpose electronic test equipment (GPETE) shall be selected from standard or substitute standard GPETE as listed in MIL-PRF-28800. (When it is determined that there is no standard or substitute standard GPETE suitable for performing the required tests, the situation shall be described, justified, and referred to the Government. Written authorization must be obtained prior to the selection of nonstandard test equipment).
- b. Equipment that is no longer manufactured nor available to the Government shall not be listed.
- c. The accuracy of the recommended test equipment shall be less than 25 percent of the tolerance allowed for the measured parameter.
- d. Common hand tools normally used at depot maintenance facilities for example, screwdrivers, wrenches, and pliers, shall not be listed in the tabular format.
- e. Unique or special maintenance and calibration requirements of the equipment listed in this section of the TRS shall be specified. If no unique or special maintenance and calibration is required of any listed equipment, the TRS shall so specify.

3.7.2.2.1 Test equipment list. The following types of equipment shall be listed:

- a. GPETE.
- b. Special purpose electronic test equipment.
- c. Automatic test equipment, and its peripheral equipment and software.
- d. Dynamic test equipment; for example, rate tables, tilt tables, centrifuges, vacuums, and atmospheric pressure equipment.
- e. Weapon system or equipment product hardware (when prescribed as a test bed for repairable items testing).
- f. Special test equipment or test set-up accessories; for example, adapters, extender cards, and connecting cables required to interface with the repairable items.
- g. Special test holding fixtures, jigs, gauges, and special handtools.
- h. Standard measuring instruments required for inspection or examination that are not normally available at depot maintenance facilities.

3.7.2.3 Personnel. The number of personnel required in the overhaul process to perform the examination, test, and repairs specified in the TRS shall be estimated. Each skill, work category, or function shall be defined and an estimate of the number of man-hours per category needed shall be provided in a brief, narrative form or in a tabular listing.

MIL-DTL-24784/7B(SH)

3.7.2.4 Test conditions. All special depot work station environmental conditions required in the overhaul process shall be so specified; for example, atmospheric pressure, temperature, relative humidity, and clean rooms, including class (see ISO 14644-1 and ISO 14644-2). This information may be presented in table format.

3.7.3 Chapter 3 - Inspection methods. This chapter shall define the conventional and any special inspection methods, procedures, and responsibilities involved in the overhaul of the items covered by the TRS. Normally, the inspection requirements specified in the TRS shall include the following.

3.7.3.1 Responsibility for inspection. A short paragraph shall specify that the quality assurance element of the overhaul activity is responsible for the performance of all inspection requirements.

3.7.3.2 Document inspection. A paragraph shall specify the requirement to review all applicable publications such as standard documents, references, drawings, and schematics to determine whether they are relevant to the items under inspection.

3.7.3.3 Initial inspection. This paragraph shall specify all initial inspection requirements (for example, visual inspection for loose, broken, or damaged parts, conductors, contacts, and terminals). It shall verify the repairable items configuration, and ensure that all applicable engineering, production, and field changes have been properly incorporated. This paragraph shall also specify that all discrepancies and defects are to be noted and corrected before proceeding with further examinations and tests.

3.7.3.4 In-process and final inspection. This paragraph shall specify (by category or type) all critical repair processing operations covered in the TRS requiring informal I&V. This information shall be presented as a tabular listing that cites the appropriate portion of the TRS (by section or paragraph number) that delineates the required inspection procedure.

3.7.4 Chapter 4 - Performance test procedure. This chapter shall provide detailed mechanical and electrical performance test procedures necessary to verify that the repairable item is operating within standards in all modes of operation. The test procedures shall serve two primary purposes:

- a. To be used as an initial performance test of the item prior to the accomplishment of the overhaul.
- b. To be used as a FAT after all required repairs have been accomplished and the repairable item is considered to be ready-for-issue (RFI).

The object of the initial functional examination is to determine the status of the repairable item as received by the depot; to compare test results with data contained in incoming repairable items discrepancy or failure reports; to identify repair item malfunctions and discrepancies; and to determine the extent of repairs required.

3.7.4.1 Performance test procedure requirements. Performance test procedure requirements

MIL-DTL-24784/7B(SH)

shall include:

- a. Safety precautions and instructions.
- b. The titles of tests or examinations to be performed.
- c. Preliminary set-up data required to perform the tests or examinations (see figure 7-6).
- d. Detailed step-by-step procedures for accomplishing the tests or examinations.
- e. Test equipment and tools. Only equipment in chapter 2 that applies to performance testing shall be specified.
- f. Other data as may be determined for the repairable items type may be shown.

3.7.4.2 Test data record. The TRS shall require that the results of the test procedure be recorded on the test data record. The satisfactory operation of the RFI repairable items shall be verified by the depot quality assurance element personnel.

- a. The data required are the procedural steps, performance requirements, TRS title, TRS number, item nomenclature, and item part number (see figure 7-7).
- b. The TRS shall also indicate that the designated depot maintenance activity responsible for the repairable items repair, shall establish and maintain a file of the completed TRS test data records.
- c. Other instructions as may be determined for the repairable items type shall be specified.

3.7.5 Chapter 5 - Overhaul procedure and FAT. This chapter shall contain all procedures, processes, and methods for the satisfactory accomplishment of all overhaul and repair work (see 6.2). It shall also contain the instructions required for the accomplishment of the FAT of the repairable items covered by the TRS. Acceptance or rejection criteria for wear, deterioration, dimensions, electrical parameters, alignments, adjustments, and other standards of acceptance shall be specified. Additional information may be required to properly accomplish particularly difficult repair actions.

3.7.5.1 Removal, disassembly, and inspection. Illustrations and step-by-step procedures (see MIL-DTL-24784) for the removal, disassembly, and inspection of the repairable items shall be developed. Disassembly instructions shall be limited to areas where the sequence of disassembly is not obvious or where special techniques are required for access to a part requiring repair. Where examinations, inspections, and tests must be performed during disassembly, the TRS shall so specify.

3.7.5.1.1 Disassembly illustrations. Illustrations shall show the sequence of disassembly and shall contain part identification data by item number, noun name, quantity, and reference designation.

3.7.5.1.2 Criteria for suitability of worn-in-parts versus new parts. Criteria to determine the suitability of worn or degraded critical parts for continued use shall be presented. The criteria shall explicitly state those measurable wear or deterioration limits which, if exceeded, require replacement by new parts. These data shall be briefly presented, preferably in table format, and shall identify the parts involved, provide the measurable limits, and specify the required actions.

MIL-DTL-24784/7B(SH)

Mandatory replacement items shall be clearly identified and reference made to the appropriate listing in the TRS Appendix A.

3.7.5.2 Cleaning and inspection. When applicable to the repairable items covered in the TRS, the process and methods of cleaning and examination to be performed on each disassembled item shall be described. Cleaning and inspection instructions shall contain the following:

- a. The pre-cleaning examination requirements and the cleaning process to be used for each item requiring cleaning.
- b. Step-by-step procedures for accomplishing the process (see 3.7.5.1).
- c. Specific identification of cleaning material to be used in the process by their commonly known name and specification number. These data may be provided in tabular format.
- d. Quantitative instructions for the variables associated with the cleaning process; for example, air pressure, moisture content, solvent temperature, soak time, ultrasonic frequency, drying time, and temperature.
- e. Procedures for use of any special tools, jigs, or fixtures required during cleaning.
- f. Post-cleaning examination, preservation, and handling instructions.
- g. Cautions, warnings, or dangers to be observed to protect personnel and equipment.
- h. Other data as may be determined appropriate for the repairable items.

3.7.5.3 Reassembly and inspection. Illustrations and all reassembly instructions and examination requirements for the reassembly of the repairable items shall be developed. The use of any special tools, jigs, fixtures, or test equipment shall be specified. If reassembly is the reverse of disassembly, a statement to that effect will satisfy this requirement. The instructions or procedures shall indicate the following:

- a. Use of corrosion-preventive compounds, paints, or other materials. Gaskets or sealing compound materials shall be specified by nomenclature, trade name, specification number, and NSN.
- b. Identification of all points requiring lubrication, the kind of lubricants required, and the method of application.
- c. The correct manner of installing all fasteners, safety wiring, cotter pins, and other locking devices.
- d. The method of aligning, adjusting, and measuring tolerances (both electronic and mechanical), clearances, end-play back-lash and tolerances between any two gears.
- e. Gearing and linkage alignment data.
- f. Identification of critical examinations and tests required during reassembly.
- g. References to tables and illustrations as applicable.
- h. Other data as may be determined appropriate for the repairable items type.

3.7.5.4 Fault location and repair. Step-by-step procedures, special instructions, examination, and technical information (including supplementary illustrations and tabular lists) shall be determined to perform effective and efficient troubleshooting and repair of the repairable items covered in the TRS. The actions to be performed shall ensure that the items shall meet or exceed

MIL-DTL-24784/7B(SH)

the specified performance requirements of the FAT (see 6.4.4) and shall satisfy all quality assurance inspection requirements.

3.7.5.4.1 Fault location. Detailed step-by-step procedures for troubleshooting and fault location to the faulty part, misalignment, or other trouble cause, shall be included.

3.7.5.4.2 Repair and replacement. Detailed step-by-step procedures for corrective actions, including the repair and replacement of defective, damaged, or deteriorated parts shall be identified or developed.

3.7.5.4.3 Alignments and adjustments. Detailed step-by-step procedures shall be identified or developed for all mechanical and electrical alignments and adjustments. Procedures shall include detail of methods used, and special tools and equipment required to achieve the setting and positioning of all (a) electronic tuning adjustments and controls, and (b) mechanical, gearing, and linkage alignments within the repairable item which, if maladjusted, would cause faulty operation.

3.7.5.4.4 Supplementary technical data requirements. If required by the TMCR (see 6.2), this section shall contain all supplementary technical information, illustrations, and tabular lists to aid the overhaul personnel in performing the specified actions. Such data shall include:

- a. Hazard or safety instructions.
- b. Test equipment and repair aids requirements. Only that equipment listed in Chapter 2 (see 3.7.2), that applies to the procedure being developed (fault location, repair and replacement, alignment) may be specified.
- c. Test set-up diagrams.
- d. Detailed step-by-step procedures for accomplishing the tests.
- e. Waveforms, truth tables, fault logic, and timing circuit diagrams.
- f. Illustrations, exploded views and gearing and linkage diagrams (see MIL-DTL-24784).
- g. Troubleshooting diagrams (see figure 7-8).
- h. Parts list and location instructions and illustrations.
- i. Printed-circuit board (PCB) foil layouts, as appropriate.
 1. Printed-circuit boards shall be illustrated foil side up. When printed wiring appears on both sides of the board, both sides shall be illustrated. All parts mounted on the board shall be outlined in black solid (front) or dashed line (rear) (even though mounted on the reverse side of the board) and their connections to the printed wiring clearly illustrated.
 2. If insufficient room exists, separate illustrations of front and rear views shall be provided. Internal elements of such items as electron tubes, coils, transformers, and transistors shall be illustrated schematically within the part outline and each part shall be labeled with the applicable reference designation.
 3. To facilitate parts location, a locating grid and corresponding guide chart shall be provided when more than 30 items are mounted on a board.
 4. Test point graphic symbols shall be located outside the board area, when not printed on the board by manufacturer, with call-out leaders drawn from these symbols to the test point locations. In like manner (when equivalent information is not printed on the board)

MIL-DTL-24784/7B(SH)

the input and output terminals shall be labeled with the functions (signals and voltages) carried, and their point of origin or destination.

- j. Other special information, instructions, methods, processes, and materials peculiar to the repair operation that are not contained elsewhere in the TRS.

Obvious repair actions, such as soldering and use of hand tools, shall not be included except where these actions involve hazards to personnel or equipment.

3.7.5.5 FAT. This section shall specify that:

- a. After accomplishment of all overhaul actions, and the repairable item is considered ready for final examination, the item shall be inspected for proper identification, workmanship quality, and subjected to the FAT (see 6.4.4) to verify satisfactory performance.
- b. The FAT shall be accomplished in accordance with the established performance parameter requirements and test procedures (see 3.7.4) and make reference to the other pertinent data contained elsewhere in the TRS.
- c. The FAT shall be witnessed by designated quality assurance personnel responsible for final inspection and acceptance of the repairable item.
- d. The test results and all required data shall be recorded on the TRS test data record (see 3.7.4.2).
- e. Upon satisfactory completion of all FAT provisions, the TRS test data record shall be verified for completeness and accuracy, and duly dated, signed, and approved by the applicable responsible depot personnel thereby certifying the satisfactory operation of the repairable electronic item and its condition as RFI to the fleet.
- f. The overhaul activity shall ensure the disposition of the completed TRS test data record as follows:
 - 1. One copy of the record shall be packaged with the repaired item for information purposes.
 - 2. One copy shall be mailed to the field maintenance agent (FMA) if a FMA has been designated for the repaired items.
 - 3. One copy shall be mailed to the technical repair agency or its designated representative.
 - 4. The original shall be retained by the overhaul activity in a central file as a permanent record of the items repair. The file shall be maintained current.

3.7.6 Packaging, handling, storage, and transportation (PHST). This chapter shall identify the PHST requirements including any special stowage (shipboard), storage (shore based), handling equipment, and transportation (delivery concepts and needs) for systems, equipment, and support items (spares and repair parts).

3.7.6.1 Packaging and handling requirements. This section shall describe the packaging and handling requirements (conventional, special, or both) applicable to the repairable items covered in the TRS. This section shall specify that the maintenance activity designated for overhaul of the

MIL-DTL-24784/7B(SH)

item shall determine and maintain the latest instructions, documentation, work details, and requirements for packaging and handling the repairable item.

3.7.6.1.1 Special handling procedures. This section shall describe the procedures required for using the special crates, boxes, containers, transportation vehicles, and other facilities for repairable items handling. If there are no requirements for special handling procedures or equipment, the TRS shall so specify.

3.7.6.1.2 Special packaging procedures. This section shall describe the procedures required for special packaging of the repairable items. If there are no requirements for special packaging procedures, the TRS shall so specify.

3.7.6.1.3 Classified repairable items. When the repairable items covered in the TRS are classified items, this section shall specify security requirements and controls necessary for proper handling, packaging, marking, storage, and shipping of the repairable items.

3.7.6.2 Special preservation, storage, and transportation requirements. This section shall identify the requirements for special preservation, storage, and transportation of the repairable items. For example, preservation for storage when the repair item is not to be installed (fleet use) for an extended period of time and the methods used for preservation and storage of the repairable items are critical. If there are no requirements for special preservation, storage, and transportation, the TRS shall so specify.

3.7.7 Appendices. The TRS shall provide pertinent supplementary and reference data required in the inspection, repair, troubleshooting, testing, final acceptance, packaging, and handling of the repairable items covered in the TRS. Each appendix shall contain a lead-in statement delineating its purpose and application.

3.7.7.1 Appendix A - Repairable item data. This appendix shall consist of repairable items, servicing and troubleshooting block diagrams, schematic diagrams, component location illustrations, and parts list tables.

3.7.7.1.1 Service and troubleshooting block diagrams. Servicing and troubleshooting block diagrams shall be included for the repairable items type covered by the TRS.

3.7.7.1.2 Repairable items schematic diagrams. Repairable items schematic diagrams shall be included for the repairable items type covered by the TRS.

3.7.7.1.3 Repairable items component location illustrations. Repairable items component location illustrations shall provide positive and rapid location of parts. Types of component location illustrations shall show exploded views, engineering drawings, and sectional views.

3.7.7.1.4 Repairable items parts list tables. Repairable items parts list tables shall be in accordance with figure 7-9.

MIL-DTL-24784/7B(SH)

3.7.7.1.5 Mandatory overhaul replacement parts list. This section shall contain a comprehensive list of items that shall be replaced regardless of observed conditions. There shall be a separate sheet listing the mandatory replacement parts (see figure 7-1) (see 6.2) for each subassembly or breakout item listed in Chapter 5. The parts to be recommended for the mandatory overhaul replacement parts list shall be dependent on the repair experience of the TRS developer and shall be specified by the Government acquisition activity by considering those parts which:

- a. Are damaged or destroyed during disassembly.
- b. Are subject to wear.
- c. Are judged to be more economical to replace than to inspect and repair.
- d. Have a history of high usage.
- e. Parts that have a high documented failure rate and are costly to replace between overhauls. No direct or indirect citation of the actual failure rate of any part is allowed. Technical manuals shall not list or cite any figures of merit for the reliability or maintainability of the equipment (or parts) at any level of indenture.

3.7.7.1.6 Contingency material list. A contingency material list shall be developed. It shall be a tabular listing of parts similar to figure 7-2. When developed, there shall be a separate sheet for each subassembly or breakout item listed in Chapter 5. The contingency material list is a guide for material that may be needed when the unit is overhauled. It shall list the parts which may require replacement during the overhaul of the unit. Any part listed in the contingency material list shall be addressed in the appropriate inspection and repair subsection of the TRS. Those parts whose costs approach or exceed the total cost of the unit shall not be listed. Parts which rarely require replacement and are not normally replacement parts for unit overhaul shall not be listed.

3.7.7.2 Appendix B - Test support equipment data. This section shall contain augmenting instructions, data, and illustrations required to fabricate, maintain, and calibrate (unique requirements) the test and repair support equipment utilized in the TRS:

- a. Examples of support equipment are: test fixtures and special electronic test equipment; mounting, holding, and support jigs; special tools and gauges; special mechanical and electrical interface or interconnection (mating) adapters, cables, and connectors, and so forth.
- b. If there are no requirements for special test support equipment data, the TRS shall so specify.

3.7.7.3 Appendix C - Test data record sheets. This section shall contain the TRS test data record sheets for the repairable items covered by the TRS.

3.7.7.4 Additional appendices (D and on). Other appendices shall be developed for the specific repairable items type covered by the TRS as required.

3.8 Ordnance TRS technical content. The sequence of ordnance TRSs shall conform to the following:

- a. Front matter (see MIL-DTL-24784).
- b. Chapter 1 - General requirements information (see 3.8.1).

MIL-DTL-24784/7B(SH)

- c. Chapter 2 - Examination, tests, and corrective actions (see 3.8.2).
- d. Chapter 3 - Planned overhaul and repair maintenance (see 3.8.3).
- e. Chapter 4 - Reassembly and grooming (see 3.8.4).
- f. Chapter 5 - FAT (see 3.8.5).
- g. Chapter 6 - Facilities, equipment and personnel requirements (see 3.8.6).
- h. Chapter 7 - Preservation, packaging, handling, storage, and transportation requirements (see 3.8.7).
- i. Chapter 8 - Overhaul and repair record requirements (see 3.8.8).
- j. Appendix A - Contingency material list (see 3.8.9b).
- k. Appendix B - Planned overhaul and repair material list (see 3.8.9a).
- l. Appendix C - Traveler and inspection, discrepancy and repair report (see 3.8.8.2).
- m. Enclosures (see 3.8.10).
- n. TMDERs (see MIL-DTL-24784).

3.8.1 Chapter 1 - General requirements information. This chapter delineates repairable end-product requirements, procedures for obtaining changes or waivers, and work flow diagrams or charts. The chapter shall include, as a minimum, the following information.

3.8.1.1 Frontispiece illustration. The front matter shall include a pictorial representation of the repairable items (see 6.4.6) covered in the TRS shall be placed on the left-hand page preceding Chapter 1 (see MIL-DTL-24784).

3.8.1.2 Content. Chapter 1 shall include statements that:

- a. The overhauling or repairing activity is responsible for overhauling or repairing the system, equipment, or component so that it satisfies the post-overhaul or repair requirements specified in Chapter 5 - FAT (see 6.4.4).
- b. When there is conflict between the TRS and original design, the requirements in the TRS and associated quality assurance test and inspection plans (QATIPs) shall take precedence. Prior to the inclusion of procedures in the TRS and QATIPs that are in conflict with original design criteria, approval shall be obtained from the LCM.
- c. Component configuration changes shall not be made when such changes will prohibit use of approved parts for the item involved unless required engineering changes, waivers, or deviations have been obtained in accordance with provisions of MIL-HDBK-61. This action shall be detailed in order to maintain authorized configurations.
- d. Production process flow charts or work flow block diagrams (see MIL-DTL-24784) graphically depicting the sequence of repair or overhaul events required to occur throughout the maintenance process described in the TRS. These displays may consist of an overall block diagram depicting the entire process with more detailed flow charts for specific phases or repair or overhaul activity. Sufficient detail should be provided to clearly illustrate the described process.

3.8.2 Chapter 2 - Examination, tests, and corrective actions. This chapter shall include maintenance requirements and associated actions, and shall include the following information.

MIL-DTL-24784/7B(SH)

3.8.2.1 Pre-overhaul and repair maintenance inspection. Examinations and inspections required prior to and during repair and refurbishment to determine the need for work in addition to that prescribed by planned overhaul or repair maintenance (see 6.4.9), commensurate with prescribed levels of maintenance shall be specified. The method of examination or inspection shall be described and acceptance and rejection criteria specified. Examples of items and examination and inspection criteria are in 3.8.2.5.

3.8.2.2 Pre-overhaul and repair performance or other evaluation tests. Performance or other evaluation tests necessary for item failure diagnosis and for the determination of requirements for corrective maintenance in addition to that prescribed by planned overhaul or repair maintenance shall be specified. Testing and evaluation requirements shall be scaled to the activity level of maintenance and shall specify the detailed steps for test accomplishment.

3.8.2.3 Corrective maintenance actions. Corrective maintenance actions appropriate to the level of maintenance which are acceptable to correct deficiencies found during pre-overhaul and repair performance tests and examinations and inspections shall be specified (see 6.2). Corrective actions include replacement, repair, or refurbishment. Where corrective actions must be accomplished and certified in accordance with a specific procedure, the TRS shall invoke the applicable procedure.

3.8.2.4 Recording results. Methods for recording inspection and examination results, and corrective actions taken shall be specified. Distribution requirements for reports shall be identified.

3.8.2.5 Inspection and acceptance criteria. Inspection and acceptance criteria shall include the following (see 6.2):

- a. Items that are subject to wear, corrosion, erosion, and aging shall be examined and tested to see whether such wear or other deterioration would ultimately result in failure to meet performance specifications. Specific acceptance criteria shall be furnished in the TRS for each such item. The criteria shall be based on actual wear, corrosion, erosion, and aging data when such data are available. These criteria shall be based on ensuring satisfactory performance for the planned period of service between refurbishments for the particular item. The criteria will in many instances be a matter of engineering judgement when wear or deterioration rates have not been established for shipboard operating conditions.
- b. Where specific parts are mentioned, the part number (NSN, national item identification number, manufacturers or Government part number as applicable), and applicable reference document shall be written in the TRS text to minimize the possibility of misunderstanding.
- c. When the technical manual includes charts of clearances and tolerances, this information may be used as a starting point in specifying allowable wear. The following list illustrates typical examples of items and applicable criteria of acceptability:
 1. Bushings or bearings and mating shafts. Clearances or dimensions.
 2. Pump wear rings or rotors. Clearances or dimensions.

MIL-DTL-24784/7B(SH)

3. Thrust bearings. End play.
4. Gear trains. Backlash, contact pattern, and alignment.
5. Pressure containing parts. Wall thickness (thinnest area, erosion path, or both), and leakage rate.
6. Couplings and shafts. Alignment and clearance.
7. Piping, valves, fittings. Thickness and leakage rate.
8. Operating mechanisms. Backlash or play.
9. Cylinders and pistons. Clearances, diameters, and leakage rate.
10. Valves, disks, and seats. Dimensions for important parts, seat angles, seat rings, ball diameters.
11. Electrical wire. Insulation resistance.
12. Switches, transformers, relays, and other electronic or electrical components. Electrical and mechanical characteristics.

3.8.3 Chapter 3 - Planned overhaul and repair maintenance.

3.8.3.1 Planned overhaul and repair requirements. Planned overhaul and repair requirements delineated in scope to appropriate level of maintenance shall be specified. These requirements shall include cleaning, refurbishing, and replacement of parts. By planned overhaul or repair work, it is intended to mean the minimum maintenance work for the system, equipment, or compound regardless of condition. These requirements shall be delineated to reflect the extent of maintenance to be performed by specific levels of maintenance such as designated overhaul activity and specialized overhaul activity (DOA/SOA), and designated repair activity and tender repair. Illustrations, diagrams and other presentation styles shall be in accordance with MIL-DTL-24784. Such requirements are not dependent on data obtained from pre-overhaul and repair examination and tests. The requirements shall be determined by application of engineering judgment and consideration of the following:

- a. Review of the design.
- b. Service of the item.
- c. Past experience.
- d. Performance requirements.
- e. Trade-off in cost and reliability between individual part replacement versus part refurbishment.

3.8.3.2 Disassembly instructions. General disassembly instructions will normally suffice except in cases when certain detailed disassembly procedures are required to prevent damage to critical components or when personnel safety may be jeopardized. In these cases, disassembly procedures and limits shall be specified to the degree appropriate to the level of maintenance. When disassembly instructions are given correctly in technical manuals, the manuals may be referenced if instructions are lengthy and require the manual to ensure clarity and comprehension. When examinations, inspections, and tests shall be performed prior to or during disassembly, the TRS shall so specify. QATIPs hold points shall be specified. Detailed disassembly instructions apply to actions required for both planned and corrective overhaul and repair maintenance.

3.8.3.3 Planned overhaul and repair material lists. Planned overhaul and repair material lists

MIL-DTL-24784/7B(SH)

shall be included (see figure 7-1). These lists shall identify those parts which are specifically required to be replaced regardless of their condition. Selected materials shall be on hand at the appropriate maintenance level activities to accomplish the planned maintenance actions in accordance with the TRS. These material lists, depending upon extent, may either be contained in the body of the TRS or placed in an appendix and referred to in the body of the TRS. No direct or indirect citation of the actual failure rate of any part is allowed. Technical manuals shall not list or cite any figures of merit for the reliability or maintainability of the equipment (or parts) at any level of indenture.

3.8.3.4 Contingency material list. Contingency material lists shall be included (see figure 7-2). These lists shall identify those parts based on engineering analysis or experience, delineated with respect to levels of maintenance, which may be expected to require some replacement. It shall be stated that the contingency material lists are provided so that the maintenance activity will have the necessary material on hand if required. It is not intended to make the acquisition of such material mandatory. Contingency material lists may be either contained in the TRS body or placed in an appendix and referred to in the body of the TRS.

3.8.3.5 Criteria for suitability of worn-in parts versus new parts. Criteria shall be provided by which the overhauling activity determines whether worn or degraded parts are suitable for continued use until the next similar overhaul or repair period. The criteria shall explicitly state those measurable, wear or deterioration limits which, if exceeded, require replacement by new parts.

3.8.3.6 Receipt inspection of new or refurbished parts. Procedures shall be included for the critical inspection and review of new parts and of overhauled and repaired parts received from DOA/SOA activities (including their comparison with parts being replaced to establish equivalency before installation).

3.8.4 Chapter 4 - Reassembly and grooming. Paragraphs in this chapter shall:

- a. Provide all necessary reassembly instructions, including required hold points for quality inspection accomplishment as delineated by QATIPs. Where such instructions are given correctly in technical documentation they shall be referenced instead of repeating lengthy instructions in the TRS. Where critical examinations and tests are required to be performed during reassembly, the TRS shall so specify.
- b. Specify grooming which is required before or during post-overhaul tests. Grooming instructions given in technical manuals shall be referenced rather than repeated in the TRS. Typical examples of grooming are:
 1. Adjustment of relief bypass valves.
 2. Rotor balancing to reduce noise levels.
 3. Honing of valve seats to reduce leakage.
 4. Improving coupling alignment.

MIL-DTL-24784/7B(SH)

- c. Specify that, upon completion of grooming, the overhaul or repair activity will place suitable data on the body of the part which will provide in legible form the following information: part number, serial number (if applicable), overhaul or repair activity identification, and the date of overhaul or repair. These data may be engraved in prepared metal plates, printed on suitable decal material, or stenciled on the part depending upon the part dimensions, use environment, and material composition. Identification methods shall be included in the TRS for the applicable item.

3.8.5 Chapter 5 - FATs. Paragraphs in this chapter shall:

- a. Specify the system, equipment, or component performance requirements.
- b. Specify the examinations and tests, including required test equipment and documentation, required to ensure that the item satisfies the above performance requirements.
- c. Specify hold points for quality inspection accomplishment as delineated by QATIPs.
- d. Specify the method of recording test data.

3.8.6 Chapter 6 - Facilities, equipment, and personnel requirements. This chapter shall note the special equipment, facilities, and personnel skills required to accomplish the equipment overhaul covered by the TRS.

3.8.6.1 Facility requirements. This paragraph shall contain a complete description of the minimum plant facilities and test beds required to accomplish the overhaul. Clean rooms and other unique requirements shall be designated when required. Care shall be taken not to over subscribe facility requirements. A summary of all utilities required such as air, water, power, steam, shall be provided.

3.8.6.2 Test equipment requirements. All the tools and test equipment required to accomplish the overhaul shall be listed in tabular form. Only tools and testing devices usually found at a well stocked repair facility may be designated unless specifically required. Equipment type, manufacturer, model number, and equivalency data and title of the test or procedural step to which it applies shall be identified (see MIL-DTL-24784).

3.8.6.3 Test conditions. All test procedures and special requirements to verify the proper overhaul of the equipment shall be included. References may be made to applicable tests, procedures, and data for clarity. If special requirements such as clean rooms, positive pressure air flow, and so forth are imposed, they shall be highlighted in this section.

3.8.6.4 Personnel requirements. The number and minimum experience level of the technician who can be expected to perform the task shall be included. If special training, skill, or experience is required to accomplish a particular step, phase of operations, or testing, it shall be noted. This section shall also identify QA personnel requirements.

3.8.7 Chapter 7 - Preservation, packaging, handling, storage, and transportation requirements. This chapter shall identify the requirements for special preservation, storage, and transportation of the repairable items. For example, preservation for storage when the item is not to be installed for

MIL-DTL-24784/7B(SH)

an extended period of time and the methods used for preservation and storage are critical. If there are no requirements for special preservation, storage, and transportation, the TRS shall so specify.

3.8.8 Chapter 8 - Overhaul and repair record requirements. The TRS shall require the recording of information during the overhaul process to:

- a. Provide a permanent record of the overhaul and repair test and inspection.
- b. Define items and areas requiring additional work.
- c. Provide data for future overhaul planning.
- d. Serve as a basis for determining the adequacy of the TRS for use on subsequent overhauls or refurbishments.
- e. Provide data for automated data processing (ADP) reporting systems as required.
- f. Serve as an information library which may be used in analyzing post-overhaul malfunctions.

3.8.8.1 Data record. Fulfillment of overhaul and repair record requirements shall be accomplished through preparation and completion of the travel and inspection, discrepancy and repair report (TIDRR) in accordance with the example format, preparation and completion instructions shown on figure 7-10. The TIDRR shall serve a dual purpose, permanent record by directing the movement of the item being overhauled and repaired from receipt to issue status, and by providing for a record of inspections, discrepancies, and overhaul and repair actions accomplished during the overhaul process. The TIDRR shall be comprised of five sections traveller, inspection and discrepancy, planned overhaul and repair actions, examinations and tests, and remarks, that will require recording, as a minimum, data required of and derived from:

- a. Examinations.
- b. Tests.
- c. Corrective actions.
- d. Disassembly, reassembly and grooming.
- e. Overhaul and repair actions.
- f. FATs.

3.8.8.2 TIDRR. The TRS originator shall provide the TIDRR data sheet form in the example format shown on figure 7-10, in quality suitable for reproduction. When completed, TIDRRs shall be retained by the overhaul and repair activity for review by the cognizant engineering agent and as a data source for repairables management program information requirements and ADP reporting systems input preparation.

3.8.9 Appendices. Appendices shall be used to separate relatively bulky information from the body of the TRS when such separation will increase the clarity of the overall TRS. When used, appendices shall be identified by capital letters (for example, (A), (B), and (C)). The following are examples of material which, may be placed in appendices:

- a. Planned overhaul and repair material list (see 3.8.3.3).
- b. Contingency material list (see 3.8.3.4).

MIL-DTL-24784/7B(SH)

- c. Format for the TIDRR (see 3.8.8.2).

3.8.10 Enclosures. Enclosures may be used to include closely related material which, is not an inherent part of the TRS. The enclosures, identified in full shall be listed by numbers (for example, (1), (2), and (3)) in the order that they are mentioned in the text.

4. VERIFICATION

4.1 Quality assurance provisions. The quality assurance requirements for delivery of book plans, review draft copies, preliminary technical manuals, final reproducible copy, technical manuals, replenishment materials, changes and revisions shall be in accordance with MIL-DTL-24784.

5. PACKAGING

5.1 Packaging. For acquisition purposes, the packaging requirements shall be as specified in the contract or order (see 6.2). When actual packaging of materiel is to be performed by DoD personnel, these personnel need to contact the responsible packaging activity to ascertain requisite packaging requirements. Packaging requirements are maintained by the Inventory Control Point's packaging activity within the Military Department or Defense Agency, or within the Military Department's System Command. Packaging data retrieval is available from the managing Military Department's or Defense Agency's automated packaging files, CD-ROM products, or by contacting the responsible packaging activity.

6. NOTES

(This section contains information of a general or explanatory nature that may be helpful, but it is not mandatory.)

6.1 Intended use. The TRS supplements the technical maintenance section of the technical manual for HM&E items, electronic items or ordnance items as applicable and provides all necessary technical information required to rebuild or restore the HM&E item, electronic item, or ordnance item. Normal maintenance and test procedures covered in the technical manual for the item should not be repeated in the TRS except when deemed necessary for clarity or continuity. Instead, reference to the manual will be made.

6.2 Acquisition requirements. Acquisition documents must specify the following:

- a. Title, number, and date of the specification (or any TMCR referencing this specification).
- b. Type and quantity of the manual required (see 1.1).
- c. Issue of DoDISS to be cited in the solicitation, and if required, the specific issue of individual documents referenced (see 2.2.1).
- d. Deliverable products and data items (see 3.3).
- e. EJRs (see 3.3.1).
- f. Cost and pricing data (see 3.3.2).
- g. Arrangement if other than standardized format (see 3.4).

MIL-DTL-24784/7B(SH)

- h. Identify whether the TRS is for HM&E equipment, electronic equipment, or ordnance equipment (see 3.4.1).
- i. Format and development instructions if other than as specified in MIL-DTL-24784 (see 3.5).
- j. When TRS will reference mandatory overhaul replacement parts list (see 3.6.4.2, 3.7.7.1.5, and 3.8.3.3)
- k. Identification of procedures, data collection and corrective actions required (see 3.6.4.5, 3.7.5.4, and 3.8.2.3)
- l. When additional appendices are required (see 3.6.8.5, 3.7.7.4, and 3.8.9)
- m. Identification of overhaul procedures (see 3.6.4, 3.7.5, and 3.8.3.1)
- n. When a separate list of mandatory replacement parts is required (see 3.7.7.1.5)
- o. Requirements for corrective maintenance actions (see 3.8.2.3).
- p. Inspection and acceptance criteria (see 3.6.4.7, 3.7.7.5, and 3.8.2.5).
- q. Packaging requirements (see 5.1).

6.3 Technical manual acquisition. This specification (or a TMCR based on this specification) must be listed on the Contract Data Requirements List (DD Form 1423) in order to acquire the technical manuals described by this specification. An alternate acquisition strategy should be devised by contracting officers for those solicitations or contracts which are exempted from using the Uniform Contract Line Item Numbering System (UCLINS).

6.4 Definitions. The words or phrases used throughout this specification must be as defined in MIL-DTL-24784 and the following.

6.4.1 Acceptance tests. An examination and test of an item after completion of its overhaul or repair to ensure that the item satisfies minimum specified performance requirements.

6.4.2 Assembly. A number of parts or subassemblies or any combination thereof joined together to perform a specific function and capable of being disassembled.

6.4.3 Critical procedures. Those procedures which:

- a. Are necessary to restore the equipment to performance specifications.
- b. If not accomplished, would prevent the equipment from operating between overhauls.
- c. Contain safety related or precautionary measures designed to minimize personal injury or equipment damage.

6.4.4 FAT. The examination and testing of repairable items after completion of overhaul or repair to ensure that the items satisfy performance requirements.

6.4.5 I & V. Inspection requirements are developed for processes that require either specialized training and certification or independent observation. Verification requirements are developed for processes that do not require independent observation. I&V requirements are identified by the shipyard technical authority to ensure that all repair, overhaul, conversion, or refurbishment of Naval ship systems, subsystems, and components fully meet Navy requirements. TRSs also state when I&V functions are to be performed. Those time periods are called I&V designated points.

MIL-DTL-24784/7B(SH)

6.4.6 Repairable item. An item of durable nature which, when unserviceable, normally can be economically restored to a serviceable condition through repair procedures performed by a Government or commercial overhaul facility.

6.4.7 Subassembly. A portion of an assembly or unit which is replaceable as a whole, but also has a part or parts which are individually replaceable. (The distinction between an assembly and a subassembly is determined by the individual application. An assembly in one instance may be a subassembly in another, where it forms a portion of an assembly.)

6.4.8 Work-unit/work-package concept. An individual unit of information containing all data necessary for a technician to perform a specific task with minimal referencing.

6.4.9 Planned overhaul and repair maintenance. The minimum overhaul or repair maintenance required for an item covered by a TRS. This work is determined by such means as experience and engineering judgment. The purpose of this requirement is to permit preplanning or repair to the maximum extent practicable to minimize potential failures before they develop into major defects or malfunctions.

6.5 Subject term (key word) listing.

Examination test and repair action record.

Material condition/overhaul report.

Material deficiency evaluation report.

Technical manual identification number.

6.6 Changes from previous issue. Marginal notations are not used in this revision to identify changes with respect to the previous issue due to the extent of the changes.

| ITEM _____ | | APPENDIX A MANDATORY OVERHAUL REPLACEMENT PARTS | | | | S9233-XXX/XXXX-XXX |
|------------|-------------|--|-----------|---------------|-----|--------------------|
| APL NO. | DESCRIPTION | NAVSEA OR MFG. DWG. NO | PC NO. | MFG. PART NO. | QTY | FSN OR NSN |
| | | | | | | |

A-XX

FIGURE 7-1. Overhaul replacement parts list, mandatory. (Sample)

| ITEM _____ | | APPENDIX B CONTINGENCY MATERIAL LIST | | | | S9233-XXX/XXXX-XXX | |
|------------|-------------|---|-----------|---------------|---------|--------------------|------------|
| APL NO. | DESCRIPTION | NAVSEA OR MFG. DWG. NO | PC NO. | MFG. PART NO. | QT Y | % usage factor | FSN OR NSN |
| | | | | | | | |

B-XX

FIGURE 7-2. Contingency material list. (Sample)

MIL-DTL-24784/7B(SH)

| | | |
|--|---|--|
| S9233-XX-TRS-XX/XXXX-XXX-XXX | | |
| MATERIAL CONDITION/OVERHAUL REPORT | | |
| SHIP: | HULL NO. | |
| AS FOUND MATERIAL CONDITION (CHECK ONE) | | |
| <input type="checkbox"/> UNUSUALLY GOOD, MAINTENANCE COULD HAVE BEEN DELAYED | <input type="checkbox"/> AS EXPECTED, MAINTENANCE WAS NECESSARY | <input type="checkbox"/> UNUSUALLY BAD, MAINTENANCE SHOULD HAVE BEEN DONE SOONER |
| REMARKS: | | |
| AS OVERHAULED CONDITION RECORD | | |
| WAS MANDATORY OVERHAUL REPLACEMENT MATERIAL (APPENDIX A) REPLACED? | YES | NO |
| | <input type="checkbox"/> | <input type="checkbox"/> |
| COULD MANDATORY OVERHAUL REPLACEMENT MATERIAL HAVE BEEN REUSED: (EXPLAIN IF YES) | YES | NO |
| | <input type="checkbox"/> | <input type="checkbox"/> |
| DID OVERHAULED ITEM MEET ALL THE ACCEPTANCE CRITERIA IN THE TRS? | YES | NO |
| | <input type="checkbox"/> | <input type="checkbox"/> |
| REMARKS: (EXPLAIN IN BLOCKS MARKED NO) | | |
| WAS THERE AN APPROVED DEVIATION OF MATERIAL OR SPECIFIED PROCEDURES? (EXPLAIN IF YES) | YES | NO |
| | <input type="checkbox"/> | <input type="checkbox"/> |
| I CERTIFY, BASED ON PERSONAL KNOWLEDGE, THAT THE ABOVE ITEM HAS BEEN SATISFACTORILY OVERHAULED AND MEETS THE ACCEPTANCE CRITERIAL PROVIDED HEREIN. | | |

FIGURE 7-3. Material condition/overhaul report.

EXAMINATION, TEST AND REPAIR ACTION RECORD

SHIP NAME & HULL NO. _____ TMAN _____

ITEM/SUBASSEMBLY _____ ITEM SERIAL NO. _____

| TRS PARA NO. | DRAWING | | LIMITS SPECIFICATION | READINGS | | CORRECTIVE ACTION TAKEN | SIGNATURES |
|--------------------|------------|-----------|-------------------------|---------------|---------|----------------------------|------------|
| | REF NO. | PC NO. | | REF LETTER | INITIAL | | |
| | | | | | | | |
| | | | | | | | |
| | | | | | | | |
| | | | | | | | |

(USE BACK OF SHEET FOR REMARKS)

C-XX

FIGURE 7-4. Examination test and repair action record.

MIL-DTL-24784/7B(SH)

SXXXX-XX-TRS-XXX

2.2.1 Minimum use specifications are the principal parameters required for performance of the required tests, and are included to assist in the selection of alternate equipment, which may be used at the discretion of the using activity. Satisfactory performance of alternate items shall be verified prior to use. All applicable equipment must bear evidence of current calibration in accordance with MIL-C-45662.

2.2.2 The instruments utilized in these procedures were selected from those known to be available at Department of Defense facilities, and the listing by make or model number carries no implication of preference, recommendation, or approval by the Department of Defense for use by other agencies. It is recognized that equivalent equipment produced by other manufacturers may be capable of equally satisfactory performance in the procedure. Alternate equipment, where necessary, shall be selected in accordance with MIL-STD-1364. Refer to Table 2-2 for recommended test equipment.

Table 2-2. Test Equipment

| MFR AND MODEL NUMBER | DESCRIPTION | MINIMUM USE SPECIFICATIONS |
|-----------------------------|-------------------------------|---|
| TS-2133/WRC-1 | Test Fixture | Test A2A6 |
| HP 606B or Equivalent | Signal Generator | 2-29 MHz at 10 aV out |
| HP 5245L or Equivalent | Frequency Counter | 1 KHz to 35 MHz |
| AN/USM-281 or Equivalent | Oscilloscope | Scope trace between 2.3-3.6 Vdc with min. ripple |
| Simpson 260 or Equivalent | Multimeter | As Required |
| Fluke 8120 or Equivalent | Digital Voltmeter | +28Vdc |
| HP 141T or Equivalent | Display and Main Frame | CRT display of information processed by HP 8443A, 8552B and 8553B |
| HP 8443A or Equivalent | Tracking Generator | 100 Kh=Hz to 100 MHz -120 dBm to +10 dBm |
| HP 8552B or Equivalent | 1-F Section | 10 dB/div log, 2 db/div log and linear displays |
| HP 8553B or Equivalent | Spectrum Analyzer/ RF Section | 1 kHz to 23.5 MHz 3 to 90 aV |
| HP 1121A or Equivalent | 500 MHz Probe | 100k ohm, 3 pf input AC, Impedance |
| NAVSECNORDIV TS-2133/WRC/A1 | MHz Repair Aid | Interface with A2A6A1 |
| NAVSECNORDIV TS-2133/WRC/A2 | 100 kHz SYN Repair Aid | Interface with A2A6A2 |
| NAVSECNORDIV TS-2133/WRC/A3 | 1 & 10 kHz Repair Aid | Interface with A2A6A3 |
| NAVSECNORDIV TS-2133/WRC/A5 | 500 Hz SYN Repair Aid | Interface with A2A6A5 |

FIGURE 7-5. Test equipment requirements table.

MIL-DTL-24784/7B(SH)

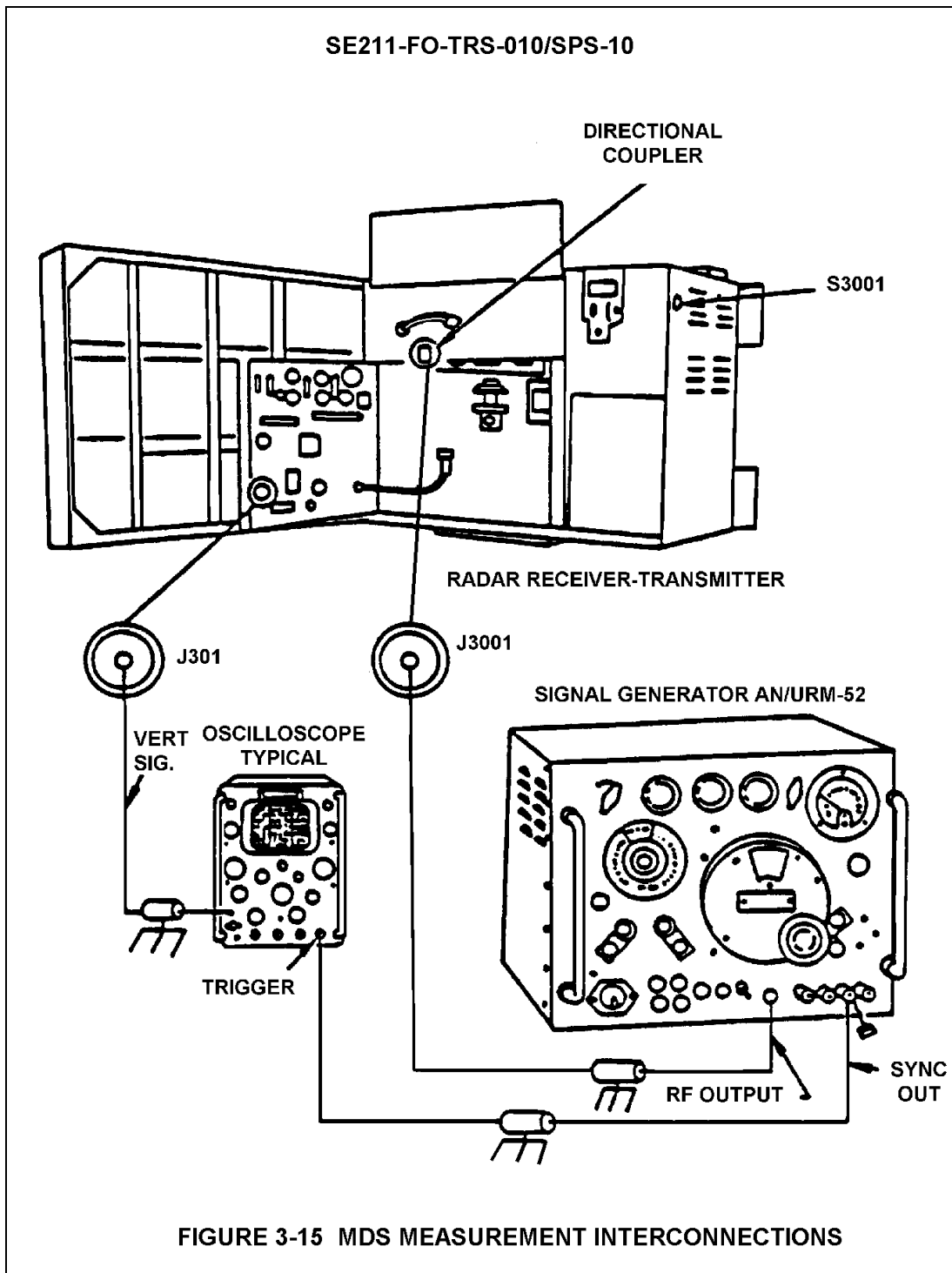

FIGURE 7-6. Performance test set-up. (Sample)

MIL-DTL-24784/7B(SH)

| SXXXX-XX-TRS-XX | | | | | |
|---|----------------------------|---|---------------------------|------------------------|------------------------|
| TRS TEST DATA RECORD | | | | | |
| DOP ACTIVITY NAME _____ | | | | | |
| LOCATION _____ | | | | | |
| TRS TITLE <u>RF AMPLIFIER ELECTRONIC ASSEMBLY</u> | | | | | |
| NOMENCLATURE | | PART NO. | SER NO. | | |
| RF AMPLIFIER ELECTRONIC ASSEMBLY | | 666230-019 | | | |
| TEST VERIFICATION CHECKLIST | | | | | |
| EQUIPMENT | | | TEST | | |
| PROC STEP | PERFORMANCE REQUIREMENT | ACTUAL PERFORMANCE (RECORD TEST RESULTS) | TEST INSPEC- TION DATE | CONDUCTOR (INITIAL) | INSPECTOR (INITIAL) |
| 4.3.1f | -1 TO -11 dB | | | | |
| 4.3.1g | ± 3 dB. MAX. VARIATION | | | | |
| 4.3.1h | ± 1 dB. MAX. VARIATION | | | | |
| 4.3.1i | ±3 dB. MAX. VARIATION | | | | |
| 4.3.1j | -1 TO -11 dB (2-20 MHz) | | | | |
| | -3 TO -15 dB (21-29 MHz) | | | | |
| 4.3.2e | -1 TO -11 dB | | | | |
| 4.3.2f | -50 dB BELOW REFERENCE | | | | |
| 4.3.2g | -14 TO -25 VDC | | | | |
| 4.3.2h | NLT - 18 Db | | | | |
| 4.3.2K | (1) NLT + 18 dB | | | | |
| DOP | | TEST RESULTS ACCEPTED BY | | | |
| TEST SUPERVISOR: | DOP: | CUSTOMER: (OPTIONAL) | | | |
| | QUALITY ASSURANCE OFFICE | AGENCY | | | |
| APPROVED: _____ | APPROVED: _____ | CONCURRED BY: _____ | | | |
| DATE: _____ | DATE: _____ | DATE: _____ | | | |
| FIGURE C-2 RF AMPLIFIER ELECTRONIC ASSEMBLY | | | | | |
| C-7 | | | | | |

FIGURE 7-7. Test data record. (Sample)

MIL-DTL-24784/7B(SH)

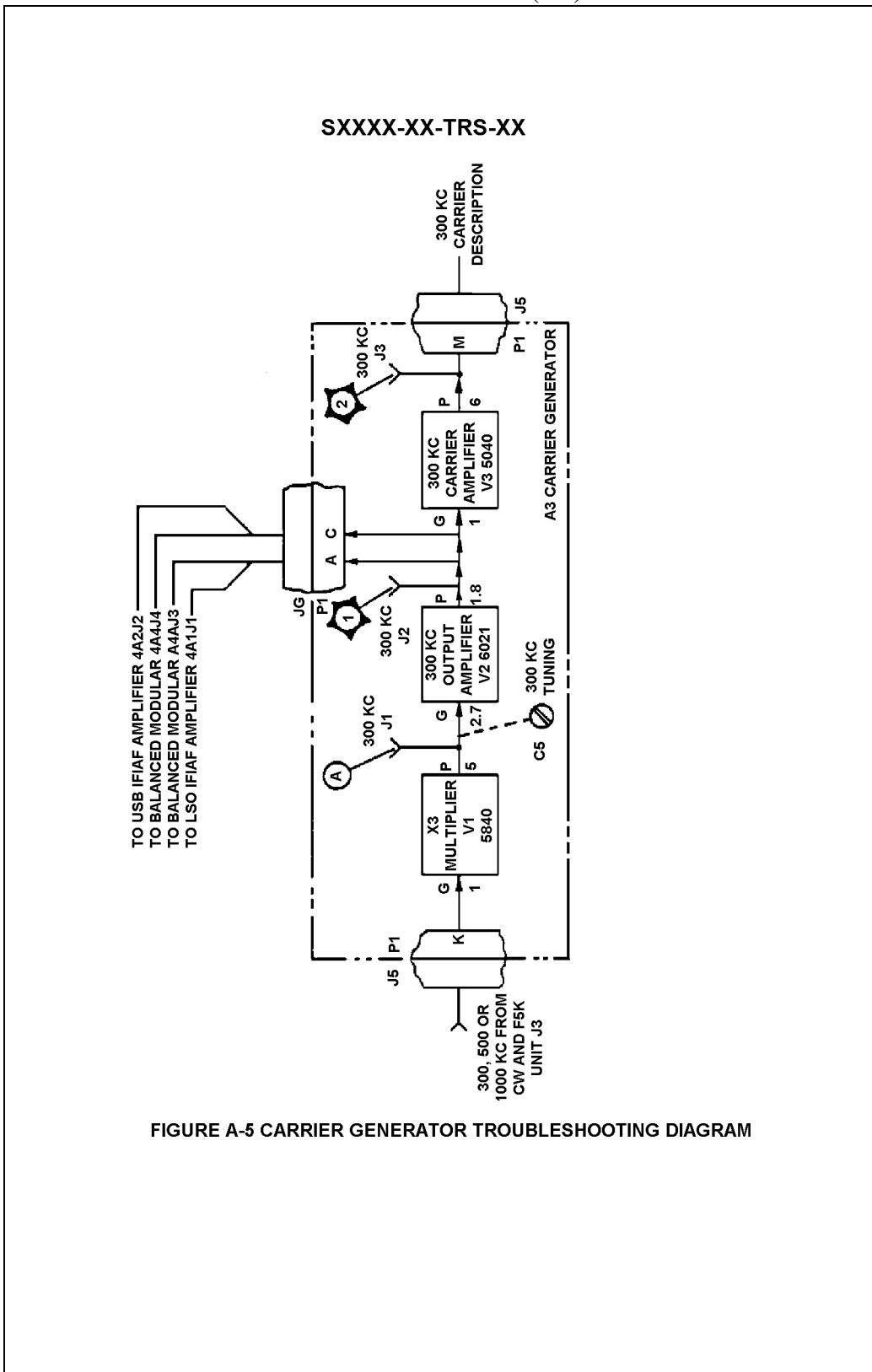

FIGURE 7-8. Repairable item troubleshooting block diagram. (Sample)

MIL-DTL-24784/7B(SH)

SXXXX-XX-TRS-XXX

TABLE A-1 REPAIRABLE ITEMS PARTS LIST

| REF DESIG | NAME AND DESCRIPTION | FIG. NO. |
|--------------|---|-------------|
| A2A6 | TRANSLATOR-SYNTHESIZER SUBASSEMBLY, Mfr 06845 PN 2058940-0501 | 5-1 |
| A2A6C1 | CAPACITOR, MIL Type CS13F470K | 5-1 |
| A2A6C2 | SAME AS A2A6C1 | 5-1 |
| A2A6J4 | CONNECTOR, Receptacle, Electrical, 2.08 x 0.42 x 0.62 in., 17 Contacts Mfr 71468, PN DBMF17W2S2C31 | 5-1 |
| A2A6J5 | CONNECTOR, Receptacle, Electrical, 2.08 x 0.42 x 0.62 in., 13 Contacts Mfr 71468, PN DBMF13W3S2C31 | 5-1 |
| A2A6J6 | CONNECTOR, Receptacle, Electrical, 2.08 x 0.42 x 0.62 in., 9 Contacts Mfr 71468, PN DBMF9W4S2C31 | 5-1 |
| A2A6P1 | CONNECTOR, Plug, Electrical, 2.72 x 0.42 x 0.62 in., 25 Contacts, Mfr 71468, PN DCM25W3P | 5-1 |
| A2A6P2 | CONNECTOR, Plug, Electrical, 1.54 x 0.42 x 0.62 in., 3 Contacts, Mfr 71468, PN DAM3W3P | 5-1 |
| A2A6P3 | SAME AS A2A6P2 | 5-1 |
| A2A6P7 | CONNECTOR, Plug, Electrical, Red, 0.14 Dia x 0.34 in., Mfr 98291, PN SKT-14 | 5-1 |
| A2A6P8 | CONNECTOR, Plug, Electrical, Green, 0.14 dia x 0.34 in., Mfr 98291, PN SKT-14 | 5-1 |
| A2A6P9 | CONNECTOR, Plug, Electrical, Orange, 0.14 dia x 0.34 in., Mfr 98291, PN SKT-14 | 5-1 |
| A2A6P10 | CONNECTOR, Plug, Electrical, Gray, 0.14 dia x 0.34 in., Mfr 98291, PN SKT-14 | 5-1 |
| A2A6P11 | CONNECTOR, Plug, Electrical, Rt Angle, 0.14 dia x 0.34 in., Mfr 06845, PN 559998-273 | 5-1 |
| A2A6P12 | SAME AS A2A6P11 | 5-1 |
| A2A6P13 | CONNECTOR, Plug, Electrical, Mfr 06845, PN 559998-299 | 5-1 |
| A2A6P14 | SAME AS A2A6P11 | 5-1 |
| A2A6P15 | SAME AS A2A6P7 | 5-1 |

A-XX

FIGURE 7-9. Repairable item parts list table. (Sample)

MIL-DTL-24784/7B(SH)

| TRAVELER AND INSPECTION / DISCREPANCY / REPAIR REPORT (TIDRR) | | | | | | | | | |
|---|--------------------------|------|--------------|-----------------|----------------|--------------|---------------|---------------|------|
| NOMENCLATURE | | FSN | | FINN/FSCM | | PART NO. | | | |
| | | | | | | | | | |
| SYSTEM TITLE | | | | EQUIPMENT TITLE | | | | | |
| | | | | | | | | | |
| JOB ORDER NUMBER: | | | | TIDRR NO. | | | | | |
| TIDRR PREP BY | | CODE | DATE | TIDRR APPR BY | | CODE | DATE | | |
| | | | | | | | | | |
| TRAVELER SECTION (T) | | | | | | | | | |
| WORK SEQ | PROCESSING OPERATION | | | WORK CTR | SHOP CODE | SHOP SUPV | MAN- HOURS | QUAL ASSUR | DATE |
| | UNPACK | | | | | | | | |
| | VISUAL INSPECTION | | | | | | | | |
| | RECEIVING TEST/EXAM. | | | | | | | | |
| | DISASSEMBLY | | | | | | | | |
| | PLANNED OVER HEAD/REPAIR | | | | | | | | |
| | IN-PROCESS TESTS | | | | | | | | |
| | CORRECTIVE ACTION | | | | | | | | |
| | ASSEMBLY | | | | | | | | |
| | PERFORMANCE TESTS | | | | | | | | |
| | GROOM/PAINT | | | | | | | | |
| | MARK/IDENTIFICATION | | | | | | | | |
| | ACCEPTANCE TEST | | | | | | | | |
| | CLAIBRATE | | | | | | | | |
| | TOUCH-UP | | | | | | | | |
| | VISUAL CHECKS | | | | | | | | |
| | FINAL ACCEPTANCE TESTS | | | | | | | | |
| | PACKING PACKAGING | | | | | | | | |
| | | | | | | | | | |
| | | | | | | | | | |
| PROCESSING | | | TIDRR REVIEW | | | | | | |
| START | COMPLETE | | SUPERVISOR | CODE | QUAL ASSURANCE | | CODE | | |
| | | | | | | | | | |

PART 1. TRAVELER SECTION (T) APPENDIX A
PAGE OF

FIGURE 7-10. Traveler and inspection, discrepancy and repair report. (TIDRR).
(Sheet 1 of 5)

MIL-DTL-24784/7B(SH)

| | | | | | |
|---|-------------------------------|-------------------------------|-------------|-------------------------------|-------------|
| TRS NO: SXXXX-XX-TRS-XXX / X-X-X | | | | | |
| ITEM NOMENCLATURE | | | | TIDRR NO. | |
| INSPECTION/DISCREPANCY RECORD | | | | | |
| NO | REPORTED DISCREPANCIES | RECOMMENDED ACTION | | | |
| | | | | | |
| <input type="checkbox"/> VERIFIED <input type="checkbox"/> NOT VERIFIED | | INSPECTOR | SHOP | DATE | |
| | | | | | |
| NO | DISCR & REC ACTION | CORRECTIVE ACTION ITEM | | QA | |
| | | | | | |
| WORK COMPLETE & SATISFACTORY | | | | | |
| DATE | SUPERVISOR | CODE | DATE | QUALITY ASSUR | CODE |
| | | | | | |
| PART 2. INSPECTION AND DISCREPANCY RECORD (I/D) | | | | APPENDIX A PAGE OF | |

FIGURE 7-10. Traveler and inspection, discrepancy and repair report (TIDRR) - Continued.
(Sheet 2 of 5)

MIL-DTL-24784/7B(SH)

TRS NO: SXXXX-XX-TRS-XXX / X-X-X

| PLANNED OVERHAUL/REPAIR ACTION RECORD | | | | | |
|---------------------------------------|---------------------|------------------------|---------------|-------------------|------|
| TRS PARA NO | ACTION ACCOMPLISHED | REPAIR PART NO USED | SHOP SUPVR | Q.A. INSP | DATE |
| | | | | | |
| WORK COMPLETE AND SATISFACTORY | | | | | |
| DATE | SUPERVISOR | CODE | DATE | QUALITY ASSURANCE | CODE |
| | | | | | |

PART 3. PLANNED OVERHAUL/REPAIR ACTION RECORD (O/R)
APPENDIX A
PAGE OF

FIGURE 7-10. Traveler and inspection, discrepancy and repair report (TIDRR) - Continued.
(Sheet 3 of 5)

MIL-DTL-24784/7B(SH)

TRS NO: SXXXX-XX-TRS-XXX / X-X-X

ITEM NOMENCLATURE:
ITEM PART NO.

TIDDR NO.
ITEM SER NO.

| EXAMINATIONS/TESTS RECORD | | | | | | |
|--------------------------------|--------------------------|----------------|--------|-------------------|-----------|--|
| | PERFORMANCE REQUIREMENTS | VALUE OR RANGE | | SHOP SUPVR | Q.A. INSP | |
| | | SPEC | OBSERV | | | |
| | | | | | | |
| WORK COMPLETE AND SATISFACTORY | | | | | | |
| DATE | SUPERVISOR | CODE | SRW | QUALITY ASSURANCE | CODE | |
| | | | | | | |

PART 4. EXAMINATION AND TEST RECORD (E/T)

APPENDIX A
PAGE OF

FIGURE 7-10. Traveler and inspection, discrepancy and repair report (TIDRR) - Continued.
(Sheet 4 of 5)

MIL-DTL-24784/7B(SH)

| | |
|---|------------------------------------|
| TRS NO. SXXXX-XX-TRS-XXX / X-X-X | |
| TIDDR NO. ITEM SER. NO. | |
| REF NO. | WRITTEN COMMENT/SIGNATURE |
| | |
| PART 5. REMARKS SHEET (R) | APPENDIX A PAGE OF |

FIGURE 7-10. Traveler and inspection, discrepancy and repair report (TIDRR) - Continued.
(Sheet 5 of 5)

MIL-DTL-24784/7B(SH)

Custodian:
Navy - SH

Review Activity:
Navy - EC

Preparing activity:
Navy - SH
(Project TMSS-N318)

STANDARDIZATION DOCUMENT IMPROVEMENT PROPOSAL

INSTRUCTIONS

1. The preparing activity must complete blocks 1, 2, 3, and 8. In block 1, both the document number and revision letter should be given.
2. The submitter of this form must complete blocks 4,5,6, and 7 and send to preparing activity.
3. The preparing activity must provide a reply within 30 days from receipt of the form.

NOTE: This form may not be used to request copies of documents, nor to request waivers, or clarification of requirements on current contracts. Comments submitted on this form do not constitute or imply authorization to waive any portion of the referenced document(s) or to amend contractual requirements.

I RECOMMEND A CHANGE:

1. DOCUMENT NUMBER

MIL-DTL-24784/7B (SH)

2. DOCUMENT DATE (YYYYMMDD)

15 February 2002

3. DOCUMENT TITLE TECHNICAL REPAIR STANDARDS (TRS) FOR HULL, MECHANICAL, AND ELECTRICAL (HM&E), EQUIPMENT, ELECTRONIC EQUIPMENT, AND ORDNANCE EQUIPMENT

4. NATURE OF CHANGE *(Identify paragraph number and include proposed rewrite, if possible. Attach extra sheets as needed)*

5. REASON FOR RECOMMENDATION

6. SUBMITTER

a. NAME *(Last, First, Middle Initial)*

b. ORGANIZATION

c. ADDRESS *(Include Zip Code)*d. TELEPHONE *(Include Area Code)*

(1) Commercial

(2) DSN

(if applicable)

7. DATE SUBMITTED

(YYYYMMDD)

8. PREPARING ACTIVITY

a. NAME

SEA 05Q

b. TELEPHONE *(Include Area Code)*

(1) Commercial

(202) 781-3726

(2) DSN

c. ADDRESS *(Include Zip Code)*

Commander, Naval Sea Systems Command
ATTN: SEA 05Q, 1333 Isaac Hull Ave SE Stop 5160,
Washington Navy Yard DC 20376-5160

IF YOU DO NOT RECEIVE A REPLY WITHIN 45 DAYS, CONTACT:

Defense Standardization Program Office (DLSC-LM)
8725 John J. Kingman Road, Suite 2533,
Fort Belvoir, VA 22060-6221
Telephone (703) 767-6888 DSN 427-6888