

INCH-POUND

MIL-DTL-24749A(SH)

21 August 1997

SUPERSEDING

MIL-S-24749(SH)

13 August 1990

## DETAIL SPECIFICATION

GROUNDING STRAPS AND BOSSES, ELECTROMAGNETIC  
GENERAL SPECIFICATION FOR

This specification is approved for use by the Naval Sea Systems Command, Department of the Navy, and is available for use by all Departments and Agencies of the Department of Defense.

## 1. SCOPE

1.1 Scope. This specification covers the general requirements and tests for electrical grounding straps, hereafter identified as bond straps and bosses.

1.2 Classification. The bond straps contained in this specification are classified into four types meeting general characteristics as follows: (see 6.1 and 6.2)

- Type I - Corrosion-resisting bond straps of CRES 316 wire rope with mounting bosses attached to each end.
- Type II - Flat CRES 316 bond strap with mounting holes in each end.
- Type III - Flat copper bond strap with mounting holes in each end.
- Type IV - Flat copper braid bond strap with mounting holes in each end.

Beneficial comments (recommendations, additions, deletions) and any pertinent data which may be of use in improving this document should be addressed to: Commander, Naval Sea Systems Command, SEA 03Q, 2531 Jefferson Davis Highway, Arlington, VA 22242-5160 by using the self-addressed Standardization Document Improvement Proposal (DD Form 1426) appearing at the end of this document or by letter.

AMSC N/A

FSC 5975

DISTRIBUTION STATEMENT A. Approved for public release; distribution is unlimited.

## MIL-DTL-24749A(SH)

## 2. APPLICABLE DOCUMENTS

2.1 General. The documents listed in this section are specified in sections 3 and 4 of this specification. This section does not include documents cited in other sections of this specification or recommended for additional information or as examples. While every effort has been made to ensure the completeness of this list, document users are cautioned that they must meet all specified requirements cited in sections 3 and 4 of this specification, whether or not they are listed.

2.2 Government documents.

2.2.1 Specifications, standards, and handbooks. The following specifications, standards, and handbooks form a part of this document to the extent specified herein. Unless otherwise specified, the issues of these documents are those listed in the issue of the Department of Defense Index of Specifications and Standards (DODISS) and supplement thereto, cited in the solicitation (see 6.2).

## SPECIFICATIONS

## FEDERAL

- FF-W-92 - Washer, Flat (Plain).
- QQ-A-200/4 - Aluminum 5083 H11 Bar.
- QQ-A-250/7 - Aluminum Alloy 5086, Plate and Sheet.
- QQ-B-575 - Braid, Wire, (Copper, Tin-Coated, or Silver Coated, Tubular, or Flat).
- QQ-N-281 - Nickel-Copper Alloy Bar, Rod, Plate, Sheet, Strip, Wire, Forgings, and Structural and Special Shaped Section.
- QQ-P-35 - Passivation Treatments for Corrosion-
- QQ-S-763 - Steel Bars, Wire, Shapes, and Forgings, Corrosion Resisting.

## DEPARTMENT OF DEFENSE

- MIL-S-1222 - Studs, Bolts, Hex Cap Screws, Socket Head Cap Screws and Nuts.
- MIL-J-24445 - Joint, Bimetallic Bonded, Aluminum to Steel.
- MIL-A-45225 - Aluminum Alloy Armor, Forged.
- MIL-F-18240 - Fastener Element Self-Locking, Threaded Fastener, 250°F Maximum.
- MIL-W-83420/2 - Wire Rope, Flexible, Type I, Composition B.

## STANDARDS

## DEPARTMENT OF DEFENSE

- MIL-STD-167-1 - Mechanical Vibrations of Shipboard Equipment (Type I - Environmental and Type II - Internally Excited).
- MIL-STD-248 - Welding and Brazing Procedure and Performance Qualification.
- MIL-STD-1252 - Inertia Friction Welding Process, Procedure and Performance Qualification.

MIL-DTL-24749A(SH)

(Unless otherwise indicated, copies of the above specifications, standards, and handbooks are available from the Defense Automated Printing Service, 700 Robbins Avenue, BLDG. 4D, Philadelphia, PA 19111-5094.)

2.3 Non-Government publications. The following document(s) form a part of this document to the extent specified herein. Unless otherwise specified, the issues of the documents which are DoD adopted are those listed in the issue of the DoDISS cited in the solicitation. Unless otherwise specified, the issues of documents not listed in the DoDISS are the issues of the documents cited in the solicitation (see 6.2).

AMERICAN SOCIETY FOR TESTING AND MATERIALS (ASTM)

- ASTM A 312 - Standard Specification for Seamless and Welded Austenitic Stainless Steel Pipes.
- ASTM A 580 - Standard Specification for Stainless Steel Wire.
- ASTM A 666 - Standard Specification for Austenitic Stainless Steel, Sheet, Strip, Plate and Flat Bar.
- ASTM B 36 - Standard Specification for Brass Plate, Sheet, and Rolled Bar. (DoD adopted)
- ASTM B 152 - Standard Specification for Copper Sheet, Strip, Plate, and Rolled Bar. (DoD adopted)

(Application for copies should be addressed to the American Society for Testing and Materials, 100 Barr Harbor Drive, West Conshohocken, PA 19428-2859.)

(Non-Government standards and other publications are normally available from the organizations that prepare or distribute the documents. These documents also may be available in or through libraries or other informational services.)

2.4 Order of precedence. In the event of a conflict between the text of this document and the references cited herein, the text of this document takes precedence. Nothing in this document, however, supersedes applicable laws and regulations unless a specific exemption has been obtained.

### 3. REQUIREMENTS

3.1 First article. When specified (see 6.2), a sample shall be subjected to first article inspection (see 6.3) in accordance with 4.3.

#### 3.2 Bond strap components.

3.2.1 Type I bond strap assembly. Type I bond strap assembly shall consist of three components: (a) one bond strap, (b) two self locking bolts and washers and (c) two (aluminum/CRES bimetallic or CRES) bosses (see figure 1).

3.2.1.1 Bond strap. A bond strap consists of two components; (a) one annealed and pickled CRES 316, 1/4" diameter stranded wire cable, and (b) two lugs fabricated from CRES 316L Schedule 80S pipe (see figure 2).

3.2.1.1.1 Stranded wire cable. Stranded wire cable shall be 1/4 inch diameter CRES 316 in accordance with MIL-W-83420/2. Wire will be annealed and pickled in accordance with ASTM A 580 condition A.

3.2.1.1.2 Lug. Lugs shall be fabricated from CRES 316L SCHED 80S pipe in accordance with ASTM A 312. The lugs shall be formed from the blank pipe as follows: prepare pipe by cutting 1 1/2 inch length; insert stranded wire through entire 1.5" length of pipe; compress end 3/4 inch to .24 inch thickness and ensure that both mounting surfaces of the lug are smooth and flat; burnish the end to remove sharp edges; drill 25/64 inch hole in the lug to facilitate 3/8" self locking bolt.

## MIL-DTL-24749A(SH)

3.2.1.2 Boss. Bosses shall be either of four different types: CRES 316L conforming to QQ-S-763; bimetallic (CRES 316L/Aluminum) in accordance with MIL-STD-1252 and MIL-J-24445; bimetallic (CRES/Brass); or bimetallic (Brass/Aluminum); (see figure 3). Bosses used with Type I bond straps shall be the CRES 316L or CRES 316L/Aluminum bimetallic.

3.2.1.2.1 Aluminum bimetallic bosses. The foot of the aluminum bosses shall be manufactured from aluminum alloy 5083 or 5456 in accordance with MIL-A-45225, aluminum alloy 5083-H11 in accordance with QQ-A-200/4, or aluminum alloy 5086 in accordance with QQ-A-250/7. The foot shall be bonded to QQ-S-763 to form the Aluminum/CRES boss or ASTM B 36 to form the Aluminum/Brass boss. An interstitial layer of an appropriate metal may be used to enhance strength and weldability. Acceptable interstitial metals include chromium, tantalum, molybdenum and titanium (see figure 3).

3.2.1.2.2 CRES/Brass bimetallic boss. The foot of the CRES/Brass bimetallic bosses shall be manufactured from CRES 316L in accordance with QQ-S-763. The foot shall be bonded to brass in accordance with ASTM B 36 (see figure 3).

3.2.1.3 Bolts and washers. Bolts and washers used in conjunction with bosses shall be fabricated from the same material as the threaded portion of the boss, for example: QQ-S-763 for CRES and ASTM B 36 for brass.

3.2.1.3.1 Bolt. The bolt shall be a 3/8 inch -16 v 3/4 inch self-locking bolt in accordance with MIL-F-18240 and MIL-S-1222. Bolts shall be made of corrosion resistant steel CRES 316, in accordance with QQ-S-763 or brass in accordance with ASTM B 36.

3.2.1.3.2 Washer, flat. The washer shall be a 3/8 inch flat washer in accordance with FF-W-92 and AN960-C616L. Washers shall be corrosion resistant steel CRES 316 in accordance with QQ-S-763 or brass in accordance with ASTM B 36.

3.2.2 Type II bond strap. Type II bond straps shall be manufactured of corrosion resistant steel (CRES 316) meeting ASTM A 666, annealed and passivated in accordance with QQ-P-35 (see figure 4).

3.2.3 Type III bond strap. Type III bond straps shall be manufactured of flat copper meeting ASTM B 152 (see figure 4).

3.2.4 Type IV bond strap. Type IV bond straps shall consist of two components; (a) one strap braid, and (b) two end terminals (see figure 5).

3.2.4.1 Braid. Bond strap braid material shall be flat copper braid in accordance with QQ-B-575.

3.2.4.2 End terminal. End terminals shall be flat copper in accordance with ASTM B 152.

3.3 Physical requirements. Bond strap dimensions shall be as specified herein. Dimensions are in inches. Strap length shall be of standard sizes as detailed on figure 8; or as specified by the contracting activity (see 6.2).

3.3.1 Type I bond strap.

3.3.1.1 Stranded wire cable. Stranded wire cable shall meet the dimensions as detailed in paragraph 3.2.1.1.1 and figure 8.

3.3.1.2 Lug. Lugs shall meet the dimensions as detailed on figure 2.

3.3.2 Type II, III, and IV bond straps. Bond straps shall be furnished in the dimensions detailed on figure 8. Bond strap dimensions shall be applicable after manufacturing. Type II and III bond strap length to width dimensions shall not be greater than a 5 to 1 ratio.

## MIL-DTL-24749A(SH)

3.3.3 Fabrication. Bond straps shall conform to the fabrication details on figure 2, and as specified herein for Type I bond straps; and figures 4 and 5 for Types II, III and IV bond straps. Standard sizes for all bond straps are shown on figure 8. Fabrication techniques shall be used which lend themselves to automation, allowing ease of manufacturing at minimum cost.

3.4 Performance requirements.

3.4.1 Visual inspection. When tested as specified in 4.5.1, bond straps shall be visually inspected to ensure conformance with the requirements specified herein (see 3.2, 3.3 and 3.5).

3.4.2 Bosses. Bosses shall be tested as specified in 4.5.2 and meet the requirements contained therein.

3.4.3 Pull test. When tested as specified in 4.5.3, Type I bond straps shall withstand a load of 1000 lbs and be maintained within plus or minus 50 lbs for 3 minutes. No visually observable wire breakage shall occur.

3.4.4 Vibration. Type I bond straps shall be tested as specified in 4.5.4. Any current interruption equal to or greater than one microsecond shall be reason for rejection of the sample.

3.4.5 Conformability and flexibility. Type I bond straps shall be tested as specified in 4.5.5. The strap shall exhibit no visual evidence of wire breakage.

3.4.6 Electrical resistance. Bond straps shall be tested as specified in 4.6.6. The strap direct current (dc) resistance shall not be greater than 1.15 milliohm per 1 inch of strap length.

3.5 Identification. Bond straps shall be marked with an identifying legend consisting of the part number (see 6.2 and 6.4), and the manufacturer's Commercial and Government Entity (CAGE) code. Type I bond strap bosses shall be marked with the metal type of the boss foot, "AL" for aluminum and "CR" for CRES. Brass/Aluminum and Brass/CRES bosses shall be marked "BA" and "BC" respectively. Marking shall be by metal stamp with a minimum character height of not less than 0.08 inches.

3.6 Recycled, recovered, or environmentally preferable materials. Recycled, recovered, or environmentally preferable materials should be used to the maximum extent possible provided that the material meets or exceeds the operational and maintenance requirements, and promotes economically advantageous life cycle costs.

3.7 Workmanship. Every detail of manufacture shall be in accordance with the best practices for manufacture of bond straps and the following:

- (a) The materials used shall be free from all defects that could adversely affect installation, appearance, or long term use.
- (b) Lug terminals, flat copper straps, and soldered terminals of flat braid straps shall be free from blistering, burrs, cracks, laps, peeling, pitting, sharp edges, slag, or other foreign material which could affect welding or bond strap installation.

3.8 JAN and J marking. The United States Government has adopted, and is exercising legitimate control over the certification marks "JAN" and "J", respectively, to indicate that items so marked or identified to, and meeting all of the criteria specified herein and in applicable specifications shall bear the certification mark "JAN" except that items too small to bear the certification mark "JAN" shall bear the letter "J". The "JAN" or "J" shall be placed immediately before the part number except that if such location would

## MIL-DTL-24749A(SH)

place a hardship on the manufacturer in connection with such marking, the "JAN" or "J" may be located on the first line above or below the part number. Items furnished under contracts or orders which either permit or require deviation from the conditions or requirements specified herein or in applicable specifications shall not bear "JAN" or "J". In the event an item fails to meet the requirements of these specification and the applicable specification sheet or associated specifications, the manufacturer shall remove completely the military part number and the "JAN" or "J" certification mark shall not be used on products acquired to contractor drawings or specifications. The United States Government has obtained Certificate of Registration Number 504,860 for the certification mark "JAN" and Registration Number 1,586,261 for the certification mark "J".

## 4. VERIFICATION

4.1 Classification of inspections. The inspection requirements specified herein are classified as follows:

- (a) First article inspection (see 4.3).
- (b) Quality conformance inspection (see 4.4).

4.2 Inspection conditions. Unless otherwise specified, all inspections shall be performed in accordance with the test conditions specified in 4.3.

4.3 First article inspection. A first article preliminary inspection shall determine that all samples are acceptable products for testing and that obvious defects are detected prior to the tests. Sample bond straps having any defect that may affect the results of first article testing shall be rejected.

4.3.1 First article testing. A first article sample of each type bond strap, as specified by the contracting activity, shall be tested and shall be representative of the bond straps to be provided.

4.3.2 Sequence of inspection. Samples shall be tested as specified in table I.

TABLE I. First article inspection and testing.

Inspection/test	Requirement	Test
<u>Type I bond strap assembly</u>		
Visual inspection	3.2.1, 3.3.1, 3.3.3, 3.4.1, 3.5, 3.7	4.5.1
Type I bond strap bosses	3.4.2	4.5.2
Pull test	3.4.3	4.5.3
Vibration	3.4.4	4.5.4
Conformability and flexibility	3.4.5	4.5.5
Electrical resistance	3.4.6	4.5.6
Packaging	Sect 5	5.1
<u>Type II, III and IV bond strap</u>		
Visual inspection	3.2.2, 3.2.3, 3.2.4, 3.3.2, 3.3.3, 3.4.1, 3.5, 3.7	4.5.1
Packaging	Sect 5	5.1

MIL-DTL-24749A(SH)

4.3.3 Number of units to be inspected. A first article sample of each type bond strap delivered under this specification shall be tested as specified.

4.4 Quality conformance inspection. Quality conformance inspections shall be as specified in tables II and III.

## MIL-DTL-24749A(SH)

TABLE II. Quality conformance inspection and testing.

Inspection test	Requirement	Test	Defect characteristic 1/
<u>Type I bond strap assembly</u>			
Visual inspection	3.2, 3,3, 3.4.1, 3.5, 3.6 and 3.7	4.5.1	Minor
Pull test	3.4.3	4.5.3	Major
Electrical resistance	3.4.6	4.5.6	Major
Packaging	Sect 5	5.1	Minor
<u>Type II, III and IV bond strap</u>			
Visual inspection	3.2, 3.3, 3.4.1, 3.5, 3.6 and 3.7	4.5.1	Minor
Packaging	Sect 5	5.1	Minor

Major defect - A defect likely to result in failure or reduce materially the usability of the product for its intended purpose.

Minor defect - A defect not likely to reduce materially the usability of the product for its intended purpose, or is a departure from established standards having little bearing on the effective use or operation of the product.

TABLE III. Quality conformance inspection sampling.

Lot size	Major characteristic	Minor characteristic
2 to 8	All	2
9 to 15	All	3
16 to 25	15	3
26 to 50	20	5
51 to 90	20	6
91 to 150	20	7
151 to 280	20	10
281 to 500	47	11
501 to 1200	47	15
1201 to 3200	53	18
3201 to 10,000	68	22
10,001 to 35,000	77	29
35,001 to 150,000	96	29

4.4.1 Inspection lot. An inspection lot is defined as items of the same type, size, material, and style produced at the same facility using the same purchased components, production processes and equipment and being offered for delivery at one time.



## MIL-DTL-24749A(SH)

4.4.2 Quality conformance inspection sampling. As a minimum, the contractor shall randomly select a sample quantity of completed bond straps for inspection and testing in accordance with the sampling plan, tables II and III, defined herein. Sample size depends on the classification of the defect characteristic as shown in table II. The sample size for each characteristic is shown in table III. As an example, for a lot size of 75 Type I bond straps, use table III to determine the number of random samples to be tested for both major and minor Defect Characteristics. For this case, 20 and 6, respectively. Return to table II, defect characteristic column, to determine if the results of a particular test is considered as major or minor. If the defect is considered "major", 20 random samples, as determined from table III, should be selected for test/inspection. If the defect is considered "minor", then only 6 random samples, as determined from table III, need be selected for test/inspection. If one or more defects is found in any sample, the entire lot shall be rejected. If a lot is rejected, the contractor has the option of screening 100 percent of the lot for the defective characteristic(s) or providing a new lot which shall be inspected and tested in accordance with the sampling plan, tables II and III contained herein. The contractor shall maintain for a period of 3 years after contract operation all records of inspections, tests, and any resulting rejections.

4.4.2.1 Rejection of a lot. Rejected inspection lots may be resubmitted for Government acceptance only if manufacturer performs 100% inspection on all bond straps in the lot for the defective characteristic(s) and replaces all defective units. Resubmitted lots shall be kept separate from the new lots and shall be clearly identified as a resubmitted lot. Resubmitted lots shall be inspected and tested in accordance with the sampling plan, tables II and III, contained herein.

4.4.2.2 Test criteria. Quality conformance testing of type I bond strap bosses shall be in accordance with 4.5.2.

#### 4.5 Methods of test.

4.5.1 Visual inspection. A visual inspection shall be performed on all samples prior to testing. The inspection shall determine that all samples are acceptable products for testing and that obvious defects are identified prior to the start of tests. The visual inspection shall determine conformance to, but shall not be limited to, the requirements of 3.2, 3.3, 3.4, 3.5, 3.6, and 3.7. Sample products having defects that may affect the result of testing shall be rejected.

4.5.2 Bosses. Quality conformance testing of boss material manufactured in accordance with MIL-STD-1252 shall consist of the following:

- (a) For every 100 items or portion thereof, of a production run, randomly select two (2) specimens for testing.
- (b) One of the specimens shall be sectioned, polished, etched, and metallographically examined at 100x magnification. Weld heat affected zone (HAZ) shall be uniform across the bond line. The bond or weld shall be uniform and free of any indications of unbonded areas or inclusions that exceed the acceptance standards of the base metal specifications.

## MIL-DTL-24749A(SH)

- (c) The remaining specimen shall be subjected to the bend test and the as-clad RAM tensile test in accordance with MIL-J-24445.
- (d) If either specimen fails, the entire lot of 100, or portion thereof, shall be discarded and the welding procedure sheet shall be verified in accordance with MIL-STD-1252.

4.5.3 Pull test. Type I bond straps shall be placed in a tensile testing configuration with the load distribution shown on figure 6 used as guidance. The load shall be 1,000 lb and maintained within plus or minus 50 lb for 3 minutes. The strap shall meet the requirements specified in 3.4.3.

4.5.4 Vibration. Type I bond straps shall be attached to a vibration table, using figure 7 as guidance, and tested in accordance with the endurance test of MIL-STD-167-1. The test frequency range shall be from 4 to 33 hertz at a table amplitude of  $0.02 \pm 0.004$  in specified therein. The test sample shall be isolated from ground, wired in series, and a current of  $100 \pm 10$  milliamperes shall be made to flow through the series circuit during the test. A suitable instrument shall be used to monitor the current flow and to indicate any discontinuity of contact or interruption of current flow equal to or greater than one microsecond. Strap assemblies shall meet the requirements specified in 3.4.4.

4.5.5 Conformability and flexibility. Conformability and flexibility of sample type I straps shall be confirmed by bending the strap 180 degrees back and forth over a 1 inch diameter pin for fifty cycles. The bending force shall be no greater than 5 lbs. The strap shall meet the requirements of 3.4.5.

4.5.6 Electrical resistance. Bond straps shall be tested for direct current resistance from end to end. The strap assembly dc resistance shall be no greater than the requirements specified in 3.4.6.

## 5. PACKAGING

5.1 Packaging. For acquisition purposes, the packaging requirements shall be as specified in the contract order (see 6.2). When actual packaging of material is to be performed by DoD personnel, these personnel need to contact the responsible packaging activity to ascertain requisite packaging requirements. Packaging requirements are maintained by the Inventory Control Point's packaging activity within the Military Department of Defense Agency, or within the Military Department's System Command. Packaging data retrieval is available from the managing Military Department's Defense Agency's automated packaging files, CD-ROM products, or by contacting the responsible packaging activity.

## 6. NOTES

(This section contains information of a general or explanatory nature that may be helpful but is not mandatory.)

## MIL-DTL-24749A(SH)

6.1 Intended use. The bond straps covered by this specification are intended for, but not limited to, shipboard bonding applications and as specified for secure electrical information processing (SEIPS) equipment bonding. Recommended usage should be as follows:

- (a) Types I and II - For bonding items in areas of environmental stresses (such as, installations exposed to the weather), where corrosion is a concern.
- (b) Types III and IV - For bonding items in non-weather exposed areas.

6.2 Acquisition requirements. Acquisition documents must specify the following:

- (a) Title, number and date of this specification.
- (b) Type of bond strap (see 1.2).
- (c) Issue of DODISS to be cited in the solicitation, and if required, the specific issue of individual documents referenced (see 2.1.1 and 2.2).
- (d) Whether other than standard bond strap lengths are required (see 3.3).
- (e) Packaging required (see 5.1).
- (f) Bond strap part number(s), when applicable (see 3.5 and 6.4.1).
- (g) Quantity of bond straps.
- (h) Boss part number(s) (see 6.4.2).
- (i) Quantity of each type boss.
- (j) Quantity of each individual component(s).
- (k) Any special instructions or remarks.

6.3 First article. When first article inspection is required, the contracting officer should provide specific guidance to offerors whether the item(s) should be first article sample, a first production item, or a standard production item from the contractor's current inventory (see 3.1) and the number of items to be tested as specified in 4.4. The contracting officer should also include specific instructions in acquisition documents regarding arrangements for examinations, approval of first article test results, and the disposition of first articles. Invitations for bids should provide that the Government reserves the right to waive the requirements for samples for first article inspection to those bidders offering a product which has been previously acquired or tested by the Government, and that bidders offering such products, who wish to rely on such production or test, must furnish evidence with the bid that prior Government approval is presently appropriate for the pending contract. Bidders should not submit alternate bids unless specifically requested to do so in the solicitation.

6.4 Part or identifying numbers (PINS).

6.4.1 Bond straps. Bond straps shall be identified by a combination of digits and letters in accordance with the following example:

## MIL-DTL-24749A(SH)

EXAMPLE: M24749-T-S-L-W-H

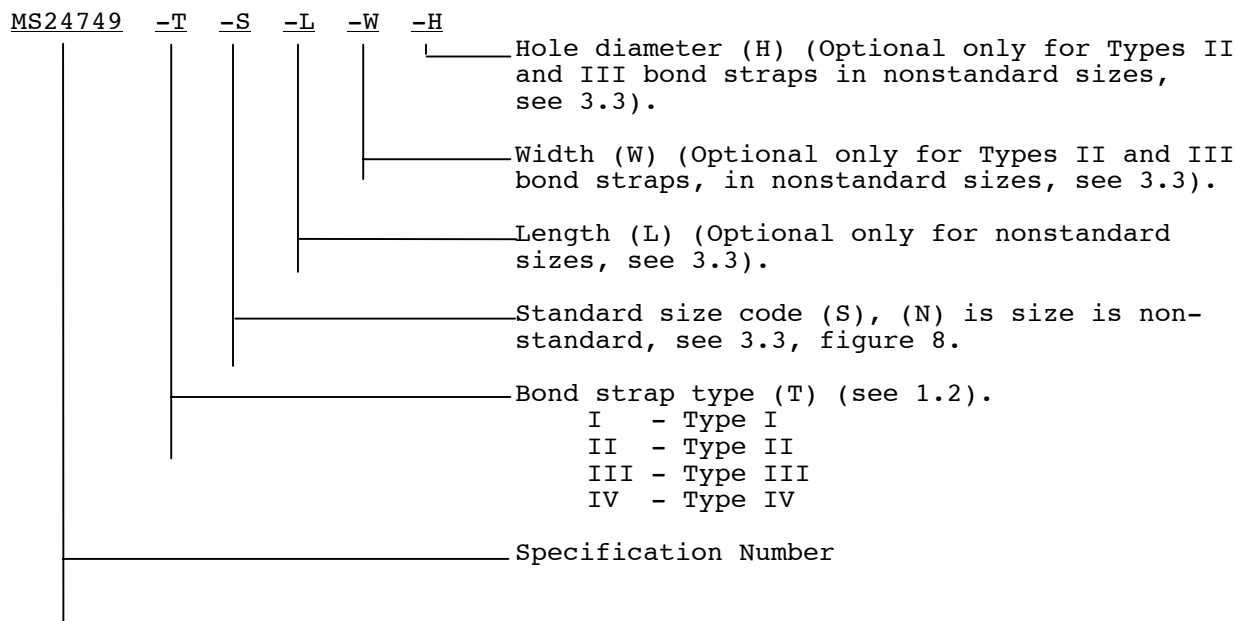

EXAMPLE: MS24749-II-B, Type II bond strap, standard size B.

EXAMPLE: MS24749-III-23-5-0.375, Type III bond strap, 23-inch length, 5-inch width, 3/8-inch (0.375-in.) hole diameter.

6.4.2 Bosses. Each boss shall be packaged and issued with one self locking bolt and flat washer. Bosses shall be identified by the following two letter designators:

AL, CR, BA, or BC

<u>Specification number</u>	<u>Bosses material</u> (see 3.2.1.2)
MS24749	AL - Aluminum to CRES 316L CR - CRES 316L BA - Brass to aluminum BC - Brass to CRES 316L

6.5 Sub-contracted material and parts. The packaging requirements of the reference documents listed in section 2 do not apply when material and parts are acquired by the contractor for incorporation into bond straps and bond strap assemblies and lose their separate identity when bond straps and bond strap assemblies are shipped.

6.6 Preservation. Bonding straps of the same type and length, or bosses of the same foot material, in the quantity specified (see 6.2), shall be unit protected in accordance with ASTM D 3951.

MIL-DTL-24749A(SH)

6.7 Packing. Commercial packing should conform to ASTM D 3951.

6.8 Strap information. Information should be furnished with the bond straps and shall include manufacturers lot number, part number, length, and marking information.

6.9 Subject term (key word) listing.

Bonding  
Bond straps  
Boss  
Bosses  
Ground Strap  
Grounding

6.10 Workmanship. MIL-HDBK-454, General Guidelines for Electronic Equipment, should be used as a guideline to ensure the use of best practices for manufacturing bond straps.

6.11 Changes from previous issue. Marginal notations are not used in this revision to identify changes with respect to the previous issue due to the extensiveness of the changes.

Preparing activity:  
Navy - SH  
(Project 5975-N095)

MIL-DTL-24749A(SH)

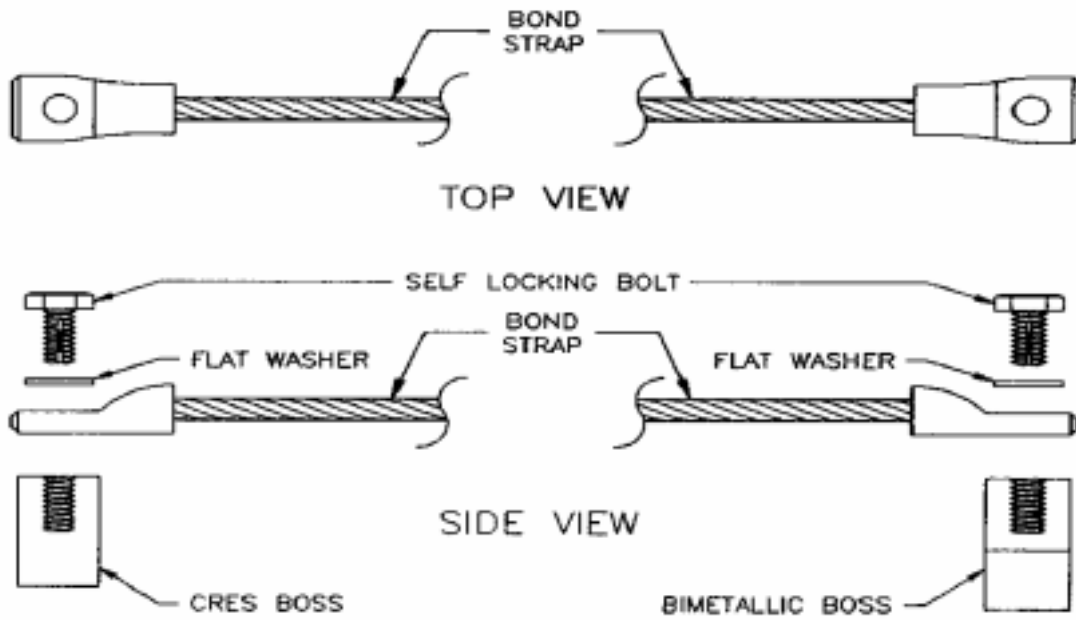
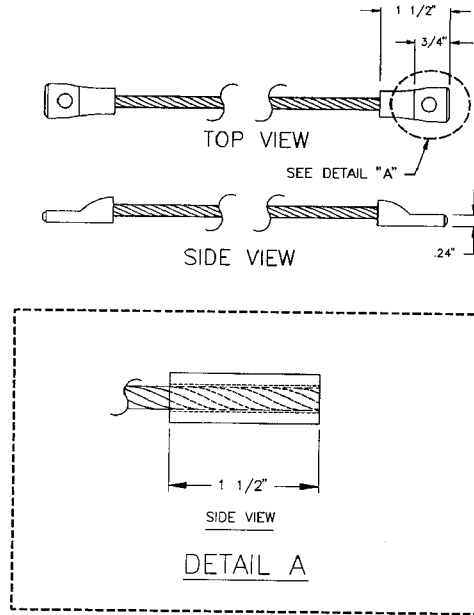

FIGURE 1. Type I bond strap assembly and associated components.

## MIL-DTL-24749A(SH)



## NOTES:

1. Insert stranded wire through entire 1.5" length of CRES 316L pipe as shown in detail "A" before compression.
2. Compress the end  $3\frac{1}{4}$ " to  $.24$ " thickness. Ensure both mounting surfaces of the lug are smooth and flat, and burnish the tip.
3. Drill  $\frac{25}{64}$ " hole in each lug to facilitate  $\frac{3}{8}$ " self locking bolts.

FIGURE 2. Bond Strap Fabrication Details.

MIL-DTL-24749A(SH)

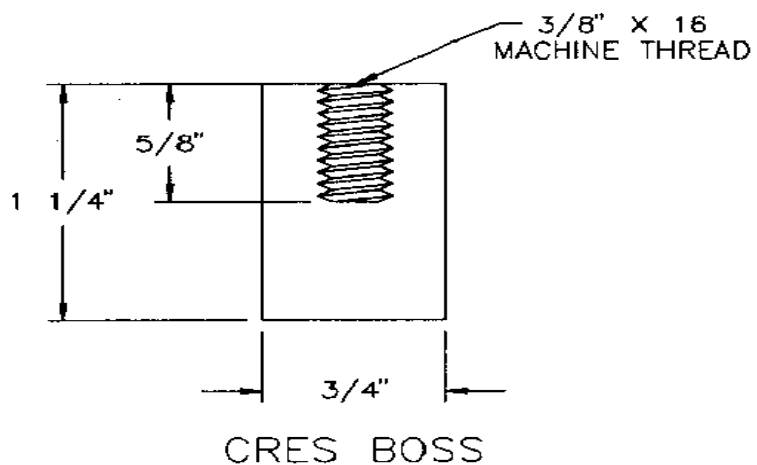
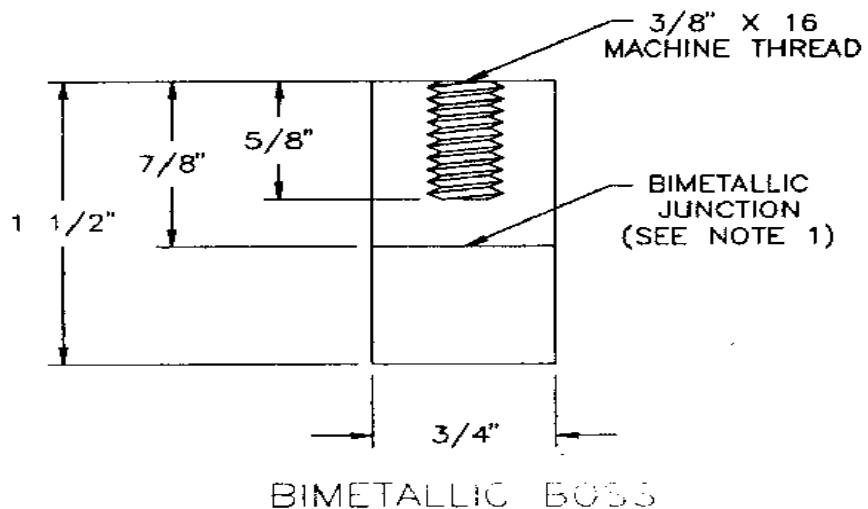

## NOTE:

1. Bolt holes shall not penetrate through bondlines of bimetallic transition layer.

FIGURE 3. Bosses.



MIL-DTL-24749A(SH)

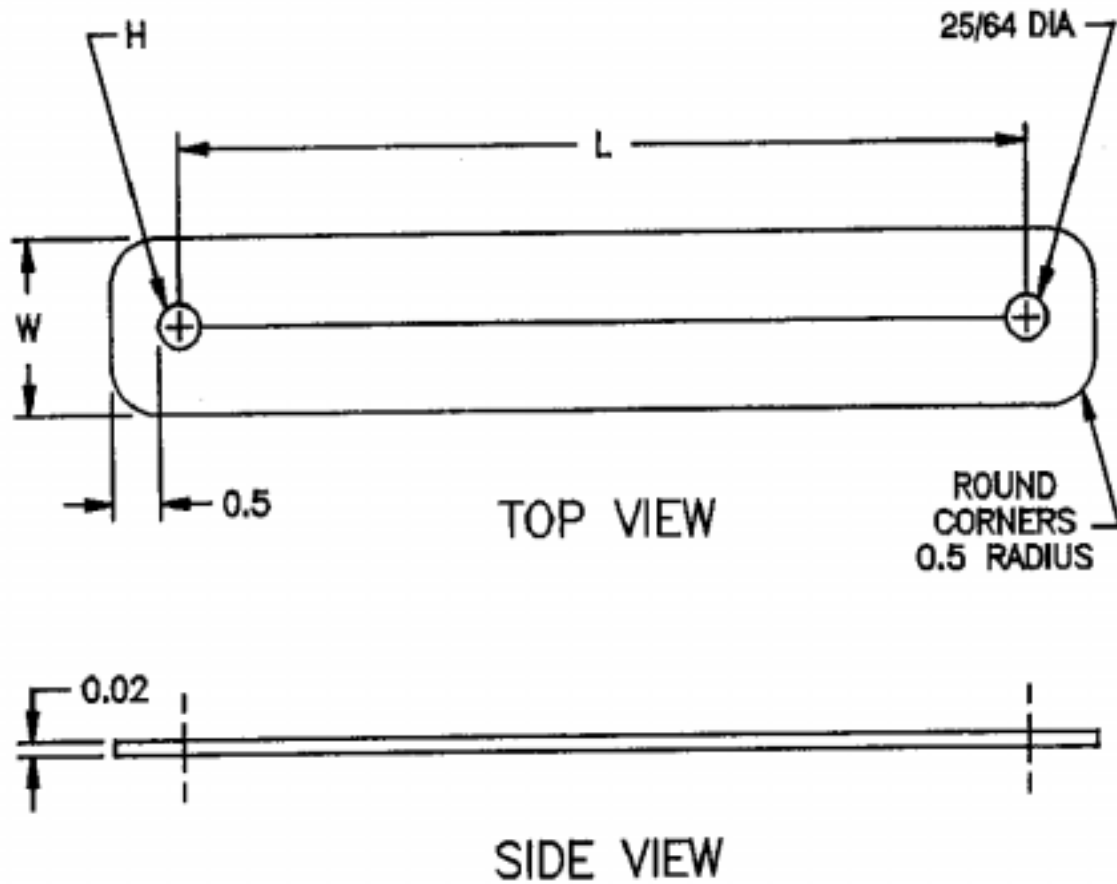

NOTES:

1. Length ( $L$ ), width ( $W$ ) and hole diameter ( $H$ ) may be specified in non-standard sizes (see 6.4.1).
2. See figure 8 for Type II and III bond strap standard sizes.

FIGURE 4. Type II and III bond strap fabrication details.

MIL-DTL-24749A(SH)

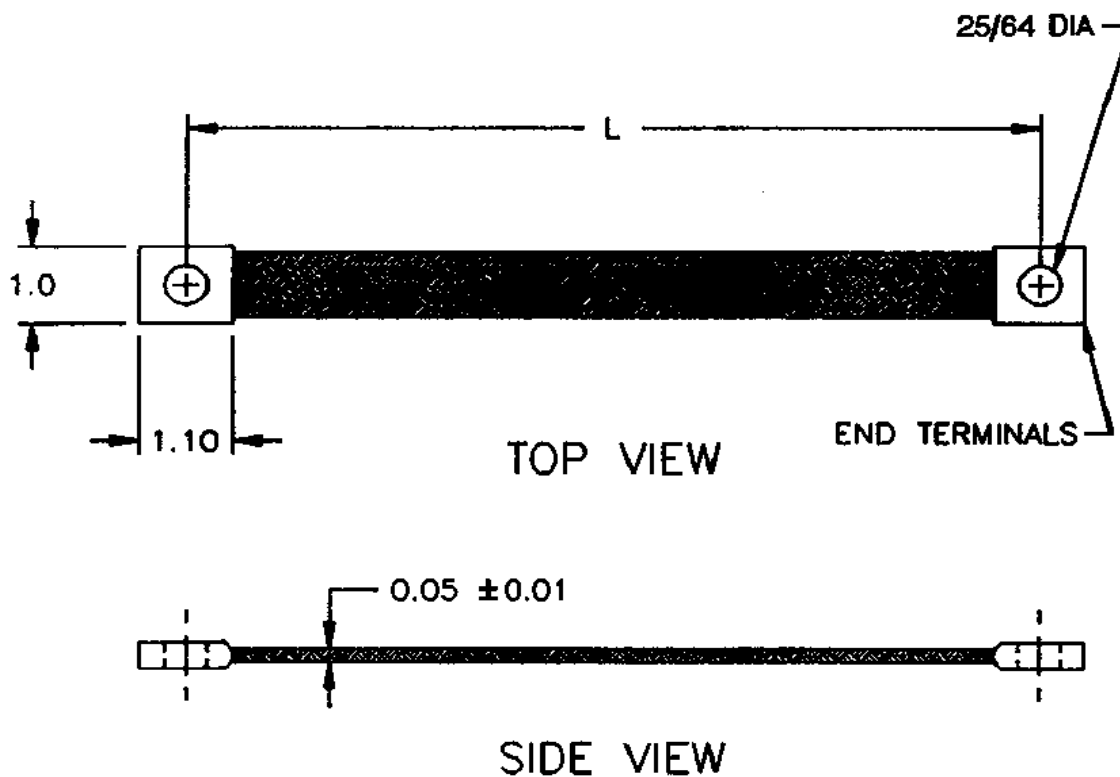

## NOTES:

1. End terminals shall be 1.18 inches long by 2 inches wide before bending.
2. End terminals shall be hot tin dipped with a coating of solder on one side. Each terminal shall be bent 180 degrees widthwise, with solder coated side on the inside of the bend, to fit the braid using a 0.0625 inch metal plate as a bending template.
3. Braid material shall be flux coated 1.0 inch on each end. End terminals shall be heated and compressed onto the braid ensuring good solder flow.
4. Holes shall be punched in each end after end terminal installation.
5. Length (L) may be specified in non-standard sizes (see 6.4.1).
6. All sizes are in inches.
7. See Figure 8 for Type IV bond strap standard sizes.

Figure 5. Type IV bond strap fabrication details.

MIL-DTL-24749A(SH)

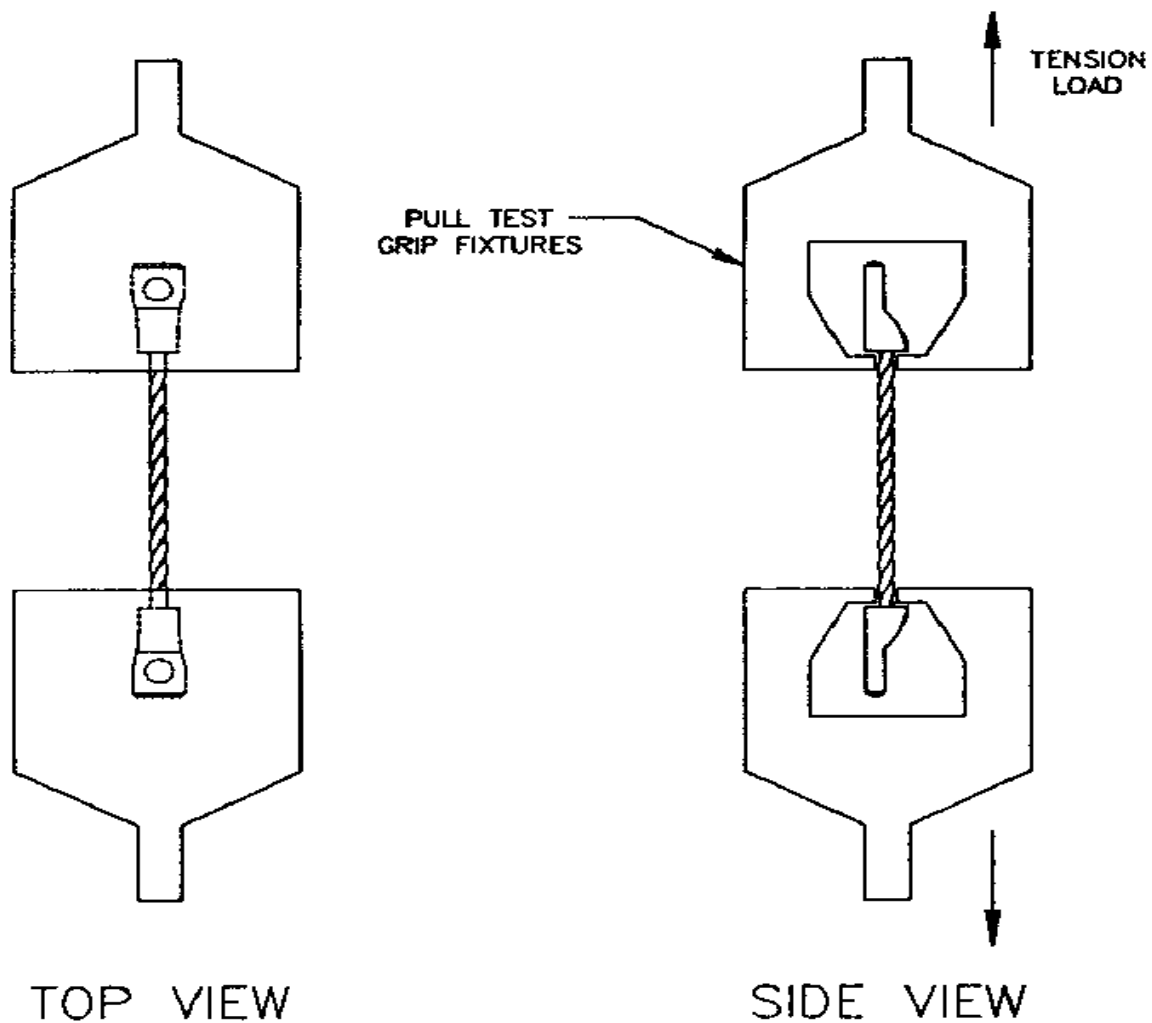

NOTES:

1. Grips shall be designed to transfer load uniformly to the base of lugs, across the diameter of lug.

FIGURE 6. Pull test.

MIL-DTL-24749A(SH)

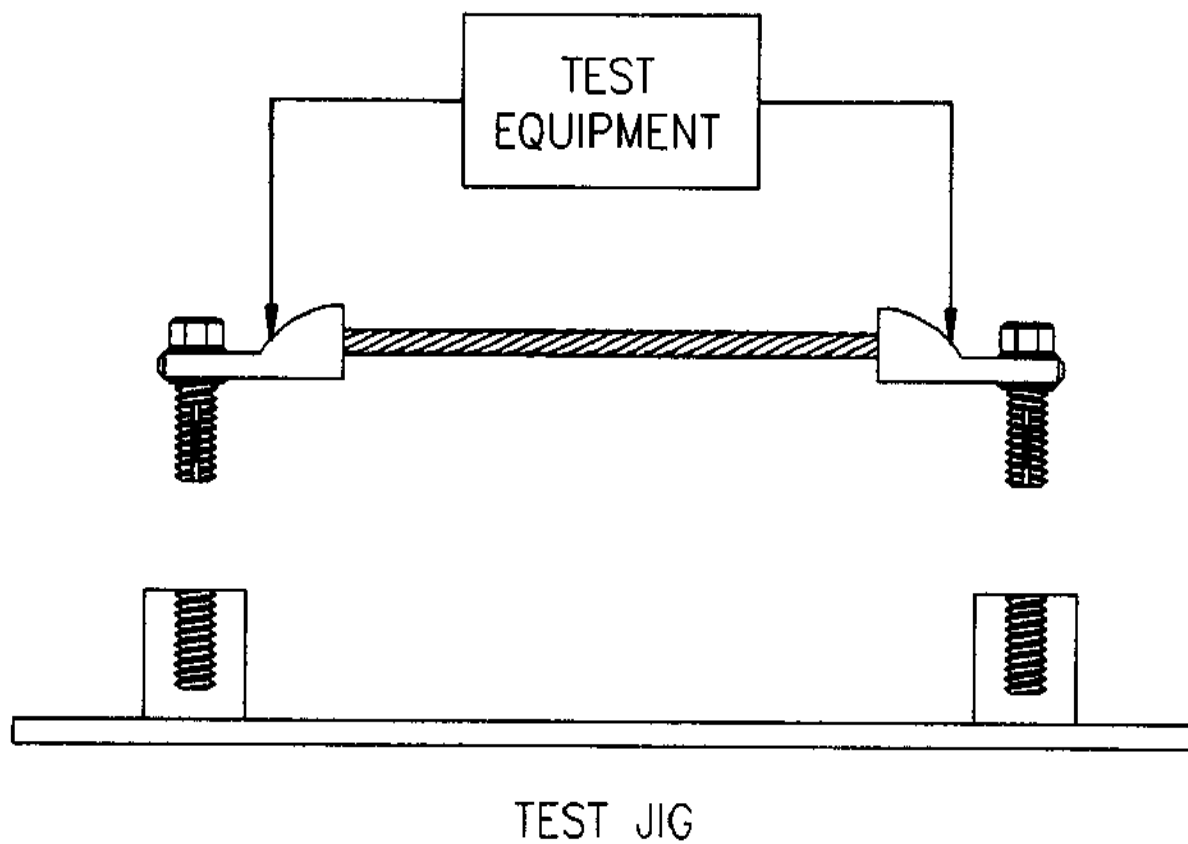

NOTES:

1. The test jig is not required for the electrical resistance test.

FIGURE 7. Test configuration.

## MIL-DTL-24749A(SH)

Standard Sizes (see 3.3)	
Standard Size Code	L (Length)
A	6.0
B	12.0
C	18.0
N	variable

FIGURE 8a. Type I bond strap standard sizes.

Standard Sizes (see 3.3)			
Standard Size Code	L (Length)	W (Width)	H (Hole Diameter)
A	3.0	1.0	25/64
B	6.0	1.5	25/64
C	9.0	2.0	25/64
D	12.0	2.5	25/64

FIGURE 8b. Type II and III bond strap standard sizes.

Standard Sizes (see 3.3)			
Standard Size Code	L (Length)	W (Width)	H (Hole Diameter)
A	6.0	1.0	25/64
B	12.0	1.0	25/64
C	18.0	1.0	25/64

FIGURE 8c. Type IV bond strap standard sizes.

## NOTES:

1. All sizes are in inches.

FIGURE 8. Standard bond strap sizes.