

INCH-POUND

MIL-DTL-24578C(SH)

w/AMENDMENT 1

1 December 2015

SUPERSEDING

MIL-DTL-24578C(SH)

31 March 2015

DETAIL SPECIFICATION

VALVES, GLOBE, PRESSURE INSTRUMENT, STEM TEST CONNECTION, UNION END

This specification is approved for use by the Naval Sea Systems Command, Department of the Navy, and is available for use by all Departments and Agencies of the Department of Defense.

1. SCOPE

1.1 Scope. This specification covers ¼-inch outside diameter (od), union end globe valves with a stem test connection (see 6.2) for use with pressure gauge and instrument tubing.

1.2 Classification. Valves are of the following types, classes, styles, and options (if applicable) as specified (see 6.2). (Part or identifying number [PIN] codes are provided along with the classifications to avoid unnecessary duplication of information in 1.3.)

1.2.1 Types. The valve types are as follows:

Type	Characteristic	PIN Code
Type I	Inline	A
Type II	Angle	B

1.2.2 Classes. The valve classes are as follows:

Class	Characteristic	PIN Code
Class 1	Stainless steel	1
Class 2	Nickel-copper alloy	2
Class 3	Nickel-chromium alloy	3

1.2.3 Styles. The valve styles are as follows:

Style	Characteristic	PIN Code
Style A	Socket weld union tailpiece	A
Style B	Heat recoverable coupling (HRC) union tailpiece	B
Style C	Without union nut, tailpiece, and tailpiece O-ring	C

Comments, suggestions, or questions on this document should be addressed to Commander, Naval Sea Systems Command, ATTN: SEA 05S, 1333 Isaac Hull Avenue, SE, Stop 5160, Washington Navy Yard DC 20376-5160 or emailed to CommandStandards@navy.mil, with the subject line "Document Comment". Since contact information can change, you may want to verify the currency of this address information using the ASSIST Online database at <https://assist.dla.mil>.

MIL-DTL-24578C(SH)
W/AMENDMENT 1

1.2.4 Options. The valve options are only applicable to Class 2, Style A valves and must specify the following tailpiece material:

Option	Characteristic	PIN Code
Option 1	Nickel-copper	1
Option 2	70/30 Copper-nickel	2

1.3 Part or identifying number (PIN). PINs to be used for globe valves acquired to this specification are created as follows: (see 1.2.1 through 1.2.4 for PIN code designations)

<u>M</u>	<u>24578</u>	<u>-</u>	<u>X</u>	<u>X</u>	<u>X</u>	<u>X</u>
Prefix for Military Specification	Specification Number	-	Type	Class	Style	Option (specified only for Class 2, Style A)
Examples: The PIN for an inline, nickel-copper alloy globe valve with a socket weld union 70/30 copper-nickel tailpiece would be M24578-A2A2. The PIN for an inline, stainless steel globe valve with a socket weld union tailpiece would be M24578-A1A.						

2. APPLICABLE DOCUMENTS

2.1 General. The documents listed in this section are specified in sections 3 and 4 of this specification. This section does not include documents cited in other sections of this specification or recommended for additional information or as examples. While every effort has been made to ensure the completeness of this list, document users are cautioned that they must meet all specified requirements of documents cited in sections 3 and 4 of this specification, whether or not they are listed.

2.2 Government documents.

2.2.1 Specifications, standards, and handbooks. The following specifications, standards, and handbooks form a part of this document to the extent specified herein. Unless otherwise specified, the issues of these documents are those cited in the solicitation or contract.

FEDERAL SPECIFICATIONS

QQ-N-281 - Nickel-Copper Alloy Bar, Rod, Plate, Sheet, Strip, Wire, Forgings, and Structural and Special Shaped Sections

DEPARTMENT OF DEFENSE SPECIFICATIONS

MIL-S-901 - Shock Tests, H.I. (High-Impact) Shipboard Machinery, Equipment, and Systems, Requirements for

MIL-C-15726 - Copper-Nickel Alloy, Sheet, Plate, Strip, Bar, Rod, and Wire

DEPARTMENT OF DEFENSE STANDARDS

MIL-STD-167-1 - Mechanical Vibrations of Shipboard Equipment (Type I – Environmental and Type II – Internally Excited)

MIL-STD-792 - Identification Marking Requirements for Special Purpose Components

(Copies of these documents are available online at <http://quicksearch.dla.mil/>.)

MIL-DTL-24578C(SH)
W/AMENDMENT 1

2.3 Non-Government publications. The following documents form a part of this document to the extent specified herein. Unless otherwise specified, the issues of these documents are those cited in the solicitation or contract.

AMERICAN NATIONAL STANDARDS INSTITUTE (ANSI)

- ANSI/ASME B1.1 - Unified Inch Screw Threads (UN and UNR Thread Form)
- ANSI/ASQ Z1.4 - Sampling Procedures and Tables for Inspection by Attributes

(Copies of these documents are available online at [http://webstore.ansi.org/.](http://webstore.ansi.org/))

ASTM INTERNATIONAL

- ASTM A269/269M - Standard Specification for Seamless and Welded Austenitic Stainless Steel Tubing for General Service
- ASTM A276/A276M - Standard Specification for Stainless Steel Bars and Shapes
- ASTM A473 - Standard Specification for Stainless Steel Forgings
- ASTM A582/582M - Standard Specification for Free-Machining Stainless Steel Bars
- ASTM B164 - Standard Specification for Nickel-Copper Alloy Rod, Bar, and Wire
- ASTM B446 - Standard Specification for Nickel-Chromium-Molybdenum-Columbium Alloy (UNS N06625), Nickel-Chromium-Molybdenum-Silicon Alloy (UNS N06219), and Nickel-Chromium-Molybdenum-Tungsten Alloy (UNS N06650) Rod and Bar
- ASTM B564 - Standard Specification for Nickel Alloy Forgings

(Copies of these documents are available online at www.astm.org.)

SAE INTERNATIONAL

- SAE-AMS-5648 - Steel, Corrosion and Heat-Resistant, Bars, Wire, Forgings, Tubing, and Rings, 17 CR – 12Ni – 2.5Mo (316) Solution Heat Treated
- SAE-AMS-7259 - Rubber: Fluorocarbon (FKM), High Temperature/Fluid Resistant, Low Compression Set/ 85 to 95 Hardness, For Seals in Fuel Systems and Specific Engine Oil Systems
- SAE-AMS-QQ-S-763 - Steel, Corrosion Resistant, Bars, Wire, Shapes, and Forgings
- SAE-AS568 - Aerospace Size Standard for O-rings

(Copies of these documents are available online at www.sae.org.)

2.4 Order of precedence. Unless otherwise noted herein or in the contract, in the event of a conflict between the text of this document and the references cited herein, the text of this document takes precedence. Nothing in this document, however, supersedes applicable laws and regulations unless a specific exemption has been obtained.

3. REQUIREMENTS

3.1 Materials. Materials shall be as specified in [table I](#) and shall be configured so as to prevent galling, seizing, or excessive wear on operating parts.

3.1.1 Recycled, recovered, environmentally preferable, or biobased materials. Recycled, recovered, environmentally preferable, or biobased materials should be used to the maximum extent possible, provided that the material meets or exceeds the operational and maintenance requirements, and promotes economically advantageous life cycle costs.

MIL-DTL-24578C(SH)
W/AMENDMENT 1

3.1.2 Hazardous materials. Materials and products utilized in this specification shall be absent of chemicals listed on the NAVSEA List of Targeted Chemicals (refer to NAVSEA for the most recent list). These chemicals pose significant risk to the user and the environment and are deemed both undesirable and unsustainable by NAVSEA. NAVSEA is minimizing the use of Hazardous Materials in the design and development of its assets. It is recommended that alternative materials be considered for associated applications to minimize the integration of targeted chemicals in NAVSEA assets delineated in this specification.

TABLE I. Materials.

Part Name	Material	Applicable Documents
Class 1		
Body	Corrosion-resisting steel (stainless steel)	ASTM A473, Type 316 or 316L SAE-AMS-QQ-S-763, Class 316
Bonnet	Corrosion-resisting steel (stainless steel)	ASTM A582/582M, Type 416
Stem	Corrosion-resisting steel (stainless steel)	ASTM A473, Type 316 SAE-AMS-QQ-S-763, Class 316 ASTM A276/A276M, Type 316 ASTM A269/269M, Grade 316 SAE-AMS-5648
Packing (O-ring)	Rubber, Fluorocarbon Elastomer	SAE-AMS-7259
Tailpiece	Corrosion-resisting steel (stainless steel)	ASTM A276/A276M, Type 304L or 316L
Bonnet and tailpiece nuts	Corrosion-resisting steel (stainless steel)	ASTM A276/A276M, Type 300 series ASTM A582/582M, Type 303
Class 2		
Body	Nickel-copper alloy	ASTM B164, QQ-N-281
Bonnet	Corrosion-resisting steel (stainless steel)	ASTM A582/582M, Type 416
Stem	Nickel-copper alloy	ASTM B164, QQ-N-281
Packing (O-ring)	Rubber, Fluorocarbon Elastomer	SAE-AMS-7259
Tailpiece	Nickel-copper alloy Copper nickel alloy ^{4/}	ASTM B164, QQ-N-281 MIL-C-15726 (70/30)
Bonnet and tailpiece nuts	Corrosion-resisting steel (stainless steel)	ASTM A582/582M, Type 303, 303Se
Class 3		
Body	Nickel-chromium alloy	ASTM B446 or ASTM B564
Bonnet	Nickel-chromium alloy	ASTM B446 or ASTM B564
Stem	Nickel-chromium alloy	ASTM B446 or ASTM B564
Packing (O-ring)	Rubber, Fluorocarbon Elastomer	SAE-AMS-7259
Tailpiece	Nickel-chromium alloy	ASTM B446 or ASTM B564

MIL-DTL-24578C(SH)
W/AMENDMENT 1TABLE I. Materials – Continued.

Part Name	Material	Applicable Documents
Class 3		
Bonnet and tailpiece nuts	Nickel-chromium alloy Corrosion-resisting steel	ASTM B446 or ASTM B564 ASTM A582/582M, Type 303, 303Se
NOTE: ^{1/} 70/30 Copper nickel tailpieces shall be limited to copper nickel tubing installations.		

3.2 Design and construction.

3.2.1 Design pressure. Valves shall operate at a pressure of 6,000 pounds per square inch (lb/in²) and shall pass the structural pressure tests specified in 3.5.

3.2.1.1 Fluid restriction. Valves shall restrict the system fluid from contacting the bonnet.

3.2.2 Dimensions and configuration. Valves shall conform to the dimensional envelope shown on [figure 1](#) with end connections in accordance with [figure 2](#). Valves shall be supplied with tailpieces, union nuts, and O-rings as shown on figures [3](#), [4](#), and [5](#), and test connection and cap as shown on [figure 1](#) (see 4.2).

3.2.2.1 Tailpieces. The tailpieces shall be of either Style A, the socket-weld coupling type, or Style B, the HRC type, as shown on figures [3](#) and [4](#), respectively (see 6.2). Ordering the valve without tailpieces shall be Style C.

3.2.2.2 Tailpiece material marking codes. The tailpieces for Class 1 and 2 valves shall be marked depending upon their material type as shown on figures [3](#) and [4](#). For Class 3 valves, a light knurl shall be used on the tailpiece's largest diameter surface where Class 1 and 2 tailpieces are marked with grooves.

3.2.3 Handwheel operation. Valves shall shut with a clockwise turn of the handwheel and open with a counterclockwise motion when viewed from directly over the handwheel (see 4.2).

3.2.4 Stem test connection. Valves shall be fitted with a stem test connection located above the handwheel. Stem test connection shall be as shown on [figure 1](#) and shall be capped. Cap shall be vented and shall seal against the stem seal to avoid inadvertent venting. Cap shall be permanently attached by a lanyard to valve bonnet. Lanyard shall be attached in such a manner as to not interfere with the operation of either the valve or the test connection. Lanyard shall be wire rope coated with flexible, translucent plastic of commercial design with suitable crimped fittings (see 4.2).

3.2.5 Union connection. Valve design shall provide for a union type connection between the body and the bonnet. The design shall also provide for a positive metal-to-metal backseat to prevent the stem from backing out of the bonnet. This shall be accomplished without the addition of separate pieces or additional operations (such as swaging). The intention is to have the stem assembled from the bottom of the bonnet (see 4.2).

3.2.6 Handwheel dimension and configuration. Valve handwheel shall not exceed the dimension shown on [figure 1](#), shall be round with a non-slip feature or "T" shaped, and shall attach to the stem so as to preclude relative motion between the stem and handwheel. The preferred method of attachment is by flats or spline. If a friction device is used to attach the handwheel to the stem, a locking method to preclude unintentional loosening of the friction device shall be included. Handwheel material shall be metal or plastic or a combination of metal and plastic (see 4.2).

3.2.7 Gauge board mounting. Valve shall include a method for mounting in a 0.640-inch diameter opening on a 1/8- to 5/16-inch thick gauge board with full "panel nut" engagement without interfering with normal valve operation. Additionally, the valve shall include a lock washer between the gauge board and the panel nut to prevent unintentional loosening. This design shall also include a method for positive prevention of unintentional loosening (see 4.2).

MIL-DTL-24578C(SH)
W/AMENDMENT 1

3.2.8 Threaded parts. Threaded parts shall have threads in accordance with ANSI/ASME B1.1 (see 4.2).

3.2.9 Locking devices. Locking devices, where required for threaded fasteners or threaded parts, shall be of the “self-locking” type (see 4.2).

3.2.10 Torque. Valves shall open and close fully with a torque applied to the stem not to exceed 62 inch-pounds (see 4.2).

3.3 Shock. Valves furnished under this specification shall pass the requirements of high-impact (HI) shock tests in accordance with MIL-S-901 supplemented with parameters and testing requirements identified in this specification (see 4.3.1).

3.3.1 Classification. Equipment and test classification shall be in accordance with Grade A, hull and bulkhead mounted principal unit, complete assembly, Class I, Type A, of MIL-S-901.

3.4 Vibration. Valves furnished under this specification shall pass the vibration requirements as specified in MIL-STD-167-1, Type I environmental vibration, up to and including 50 cycles per second (see 4.3.2).

3.5 Structural soundness. Valves shall withstand the following:

a. Valve body and test connection shall withstand an operating pressure of 6,000 lb/in² and a test pressure one and one half times the operating pressure (see 4.3.3).

b. Valve seats shall withstand a hydrostatic gauge pressure of 6,000 lb/in² above and below the seat (see 4.3.3).

c. Valves shall withstand a pneumatic gauge pressure of 100 lb/in² above and below the seat (see 4.3.3).

3.6 Marking.

3.6.1 Valve marking. Each valve shall be low stress die stamped, electro, vibro, or laser etched on the body in accordance with MIL-STD-792, legibly, as follows (see 3.6.2 and 4.2):

a. 6,000 water, oil, and gas (WOG)

b. ¼-inch

c. Manufacturer’s name or trademark

d. Direction of flow shall be marked on the side of the body

e. Manufacturer’s drawing number

f. MIL-DTL-24578

3.6.2 Identification plates. When body configuration does not allow space, an identification plate shall be supplied with each valve and shall contain statements 3.6.1e and 3.6.1f.

3.7 Special tools. Special tools shall not be required to install or service the valves. Special tools are defined as those tools not listed in the Federal Supply Catalog. Copies of this catalog may be consulted in the office of the Defense Contract Management Agency (DCMA).

4. VERIFICATION

4.1 Sampling for conformance inspection.

4.1.1 Inspection lot. An inspection lot shall consist of all valves of the same type and class produced under essentially the same conditions and offered for delivery at one time.

4.1.2 Sampling for visual and dimensional examination. Sampling of each lot for visual and dimensional examination as specified in 4.2 shall be conducted in accordance with ANSI/ASQ Z1.4, as specified (see 6.2).

4.2 Visual and dimensional examination. Sample valves shall be visually and dimensionally examined to determine conformance with the applicable drawings and with the requirements specified in 3.2.2 through 3.2.10 and 3.6.

MIL-DTL-24578C(SH)
W/AMENDMENT 1

4.3 Tests.

4.3.1 Shock test. Each type and class valve design shall be shock tested to ensure compliance with the requirements specified in 3.3 and shall be subject to review for similarity of design and materials. Evidence of previously conducted successful tests may be accepted as meeting this test.

4.3.1.1 Shock test procedure. Valves shall be hydrostatically pressurized internally to 6,000 lb/in². Testing medium shall be clean tap water with no additive other than cutting oil at temperatures not less than 40 °F nor exceeding 100 °F. A total of nine blows shall be applied in accordance with MIL-S-901 for each condition and position specified in [table II](#) below. Momentary malfunction at the time for impact blow is permitted and acceptable. Permanent deformation, misalignment, or functional impairments shall be cause for rejection.

TABLE II. HI shock tests.

Component Type	Positions	Pressure Condition
Throttling	Full closed	Pressurized on inlet side
Globe, angle, throttle, dump, reducing, needle, sleeve	Disc at mid-position not on either seat	Pressure throughout

4.3.1.2 Shock test examination. Each valve tested shall receive a complete visual and dimensional examination before and after the post shock tests. The “before” visual and dimensional tests shall be performed on the external surfaces only since the valve is not to be disassembled for internal visual and dimensional checking until after all post shock tests have been completed. No relaxation or deviations in post shock testing shall be permitted unless specifically approved by NAVSEA.

4.3.1.3 Post shock tests. The following minimum post shock tests are required in all cases, whether or not a specification or drawing exists. The tests shall be conducted in the order listed, as follows:

- a. An external visual and dimensional check. Do not disassemble the valve. This may include a dye penetrant or magnetic particle inspection, depending upon the requirements of individual contracts.
- b. A hydrostatic test, to the full cold rated pressure. This pressure shall be maintained for at least 10 minutes.
- c. A seat tightness test, maintained for at least 3 minutes.
- d. A final visual and dimensional check including valve internals.

4.3.1.4 Shock test pass/fail. The valve shall pass all post shock tests without exception. In the case of the visual and dimensional checks, any permanent damage that is detrimental to the valve shall be considered cause for rejection. This shall include any permanent deformation of any pressure containing part.

4.3.1.5 Adjustments. Adjustments to correct minor malfunctions during shock tests shall be permitted within the scope of what a person on watch could be expected to do without leaving the station. For example, tightening a packing gland is permissible. Replacing a yielded or sheared bolt is not.

4.3.2 Vibration test. Each valve design shall be vibration tested under normal operating conditions to duplicate shipboard installation and shall successfully meet the requirements specified in 3.4.

4.3.3 Structural soundness test. Each valve shall be hydrostatically tested, as follows, to ensure compliance with the requirements specified in 3.5. Any weeping, leakage, or permanent deformation shall be cause for rejection.

- a. Hydrostatically test body and test connection cap assembly with the valve in the half open position at 9,000 lb/in² for 1 minute. Permanent deformation shall be cause for rejection.
- b. Hydrostatically test valve and seat after hand closure, in accordance with 3.5, on each side of the seat at 6,000 lb/in² for 1 minute. Zero leakage shall be permitted.
- c. Air test above and below seat after hand closure, in accordance with 3.5, under water or with soap suds at 100 lb/in². Zero leakage shall be permitted.

MIL-DTL-24578C(SH)
W/AMENDMENT 1

4.3.4 Stem back-out test. With valve in the full open position, the valve shall be turned counterclockwise by hand. Valve shall resist further opening through the stem back-out device, and the positive method specified in 3.2.5 shall prevent the stem from backing out of the body. The torque to be applied for this test shall be three times the maximum permissible operating torque (see 3.2.10).

5. PACKAGING

5.1 Packaging. For acquisition purposes, the packaging requirements shall be as specified in the contract or order (see 6.2). When packaging of materiel is to be performed by DoD or in-house contractor personnel, these personnel need to contact the responsible packaging activity to ascertain packaging requirements. Packaging requirements are maintained by the Inventory Control Point's packaging activities within the Military Service or Defense Agency, or within the military service's system commands. Packaging data retrieval is available from the managing Military Department's or Defense Agency's automated packaging files, CD-ROM products, or by contacting the responsible packaging activity.

6. NOTES

(This section contains information of a general or explanatory nature that may be helpful, but is not mandatory.)

6.1 Intended use. Valves covered by this specification are intended for use as an instrument piping isolation valves (gauge valves). 70/30 Copper nickel tailpieces may be limited to copper nickel tubing.

6.2 Acquisition requirements. Acquisition documents should specify the following:

- a. Title, number, and date of this specification.
- b. Type, class, style, and option (if applicable) of valve required (see 1.2 and 3.2.2.1).
- c. Specific requirements for sampling (see 4.1.2).
- d. Packaging requirements (see 5.1).

6.3 Ordering data. DELETED

6.3.1 Ordering example. DELETED

6.3.2 Data requirement. DELETED

6.4 Sub-contracted material and parts. DELETED

6.5 Subject term (key word) listing.

Angle valve

Heat recoverable coupling

Inline valve

Socket weld union

6.6 Changes from previous issue. DELETED

6.7 Amendment notations. The margins of this specification are marked with vertical lines to indicate modifications generated by this amendment. This was done as a convenience only and the Government assumes no liability whatsoever for any inaccuracies in these notations. Bidders and contractors are cautioned to evaluate the requirements of this document based on the entire content irrespective of the marginal notations.

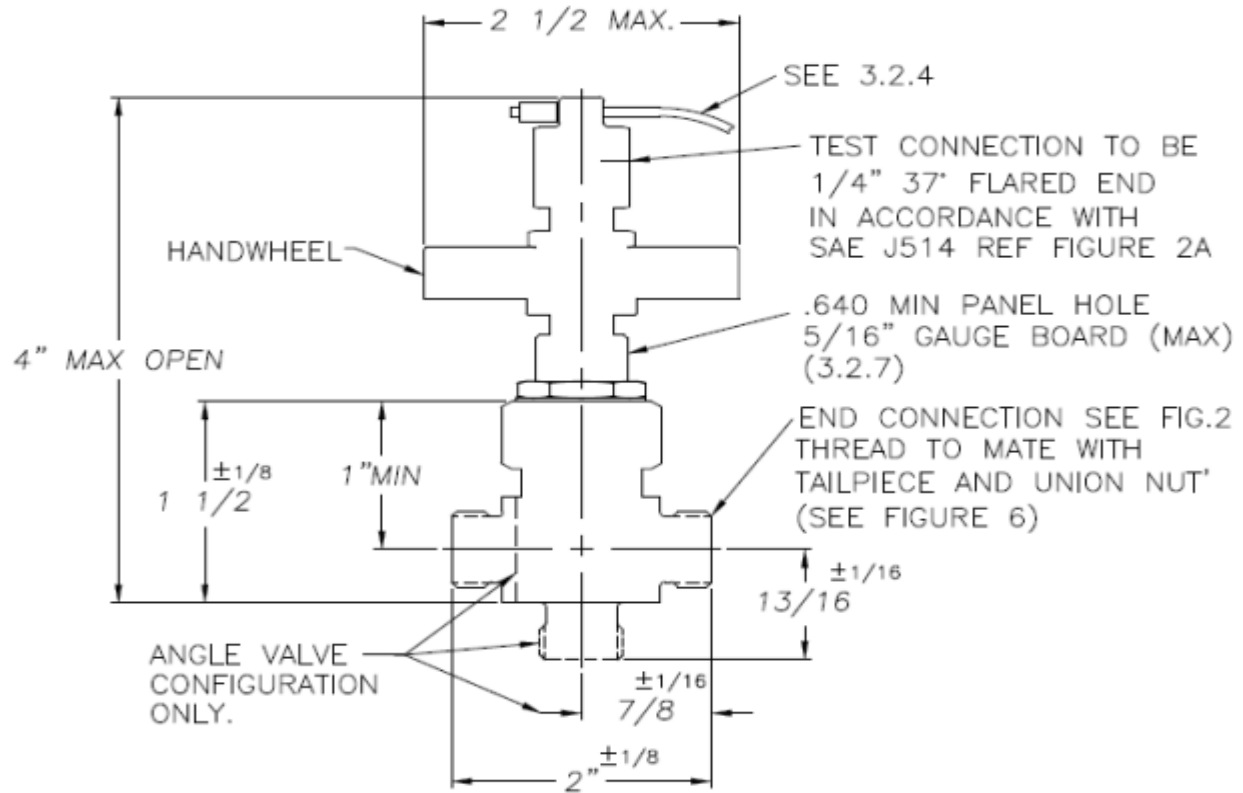
MIL-DTL-24578C(SH)
W/AMENDMENT 1

NOTE: TEST CONNECTION CAP SHALL BE SUITABLY DRILLED $\frac{1}{16}$ DIA FOR VENTING.

FIGURE 1. Valve envelope dimensions.

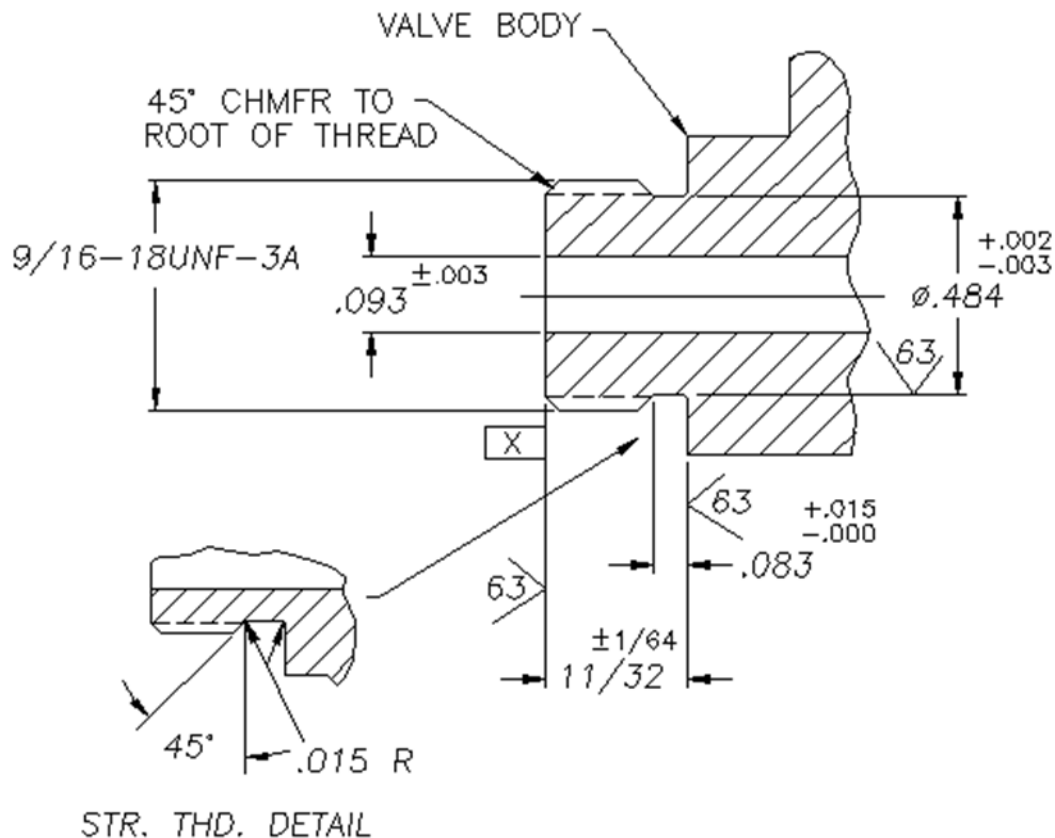
MIL-DTL-24578C(SH)
W/AMENDMENT 1

NOTE:

1. 9/16 THD. TO BE PERPENDICULAR WITH WITH SURFACE "X" WITHIN .003 T.I.R.
2. ALL DIA'S TO BE CONCENTRIC WITH EACH OTHER WITHIN .003 T.I.R.

FIGURE 2. End connection detail.

MIL-DTL-24578C(SH)
W/AMENDMENT 1

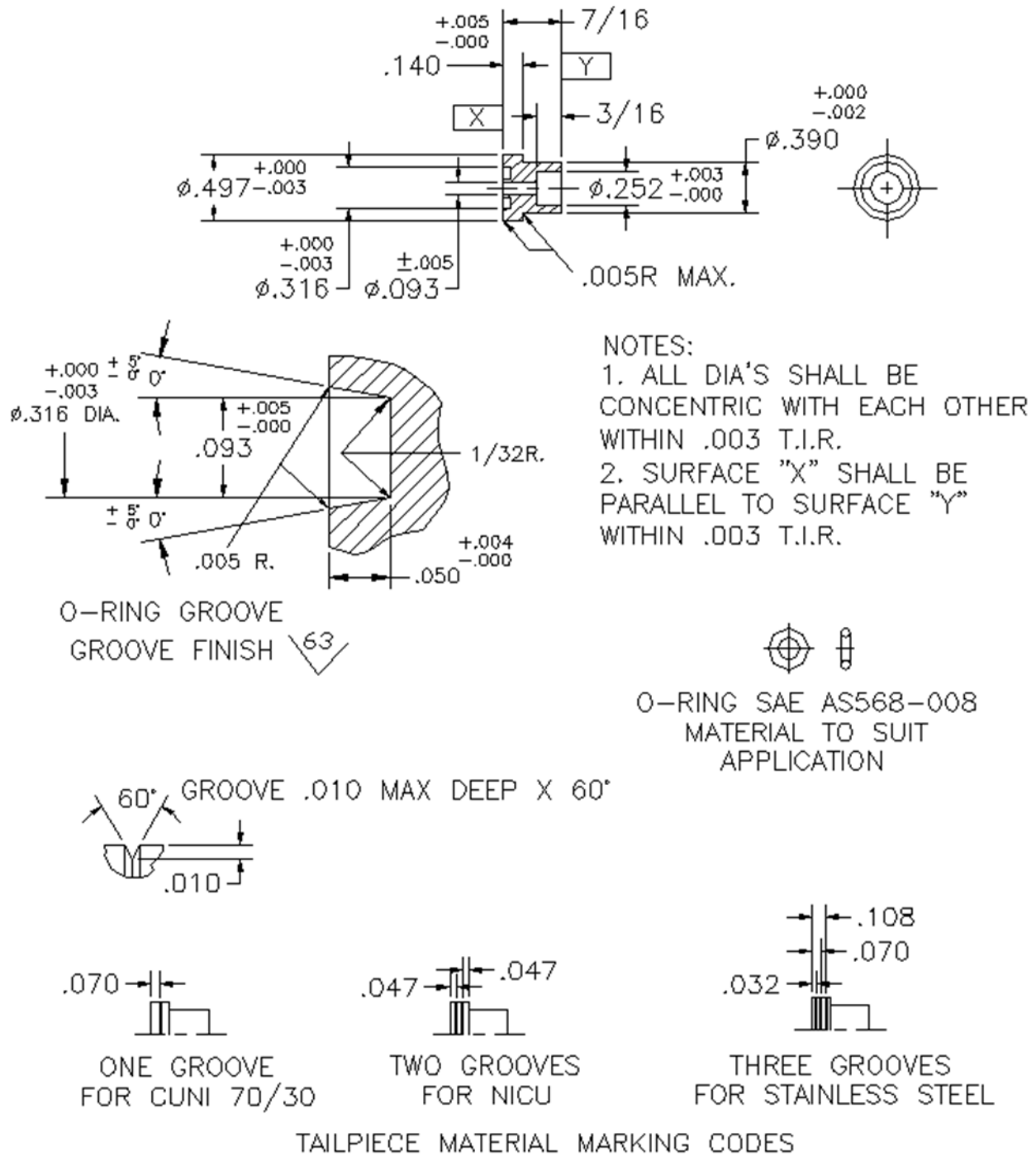

FIGURE 3. Tailpiece – socket weld.

MIL-DTL-24578C(SH)
W/AMENDMENT 1

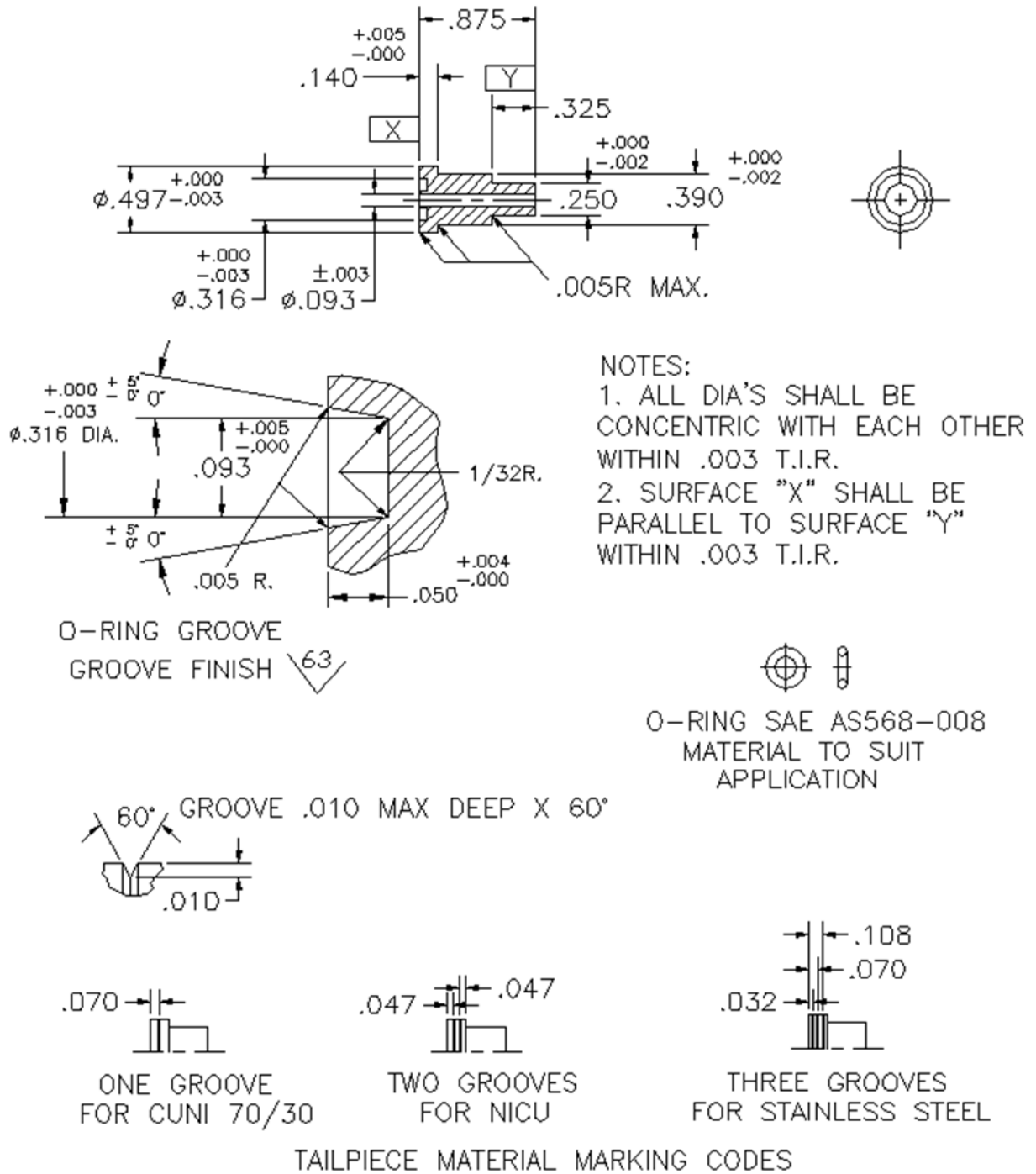
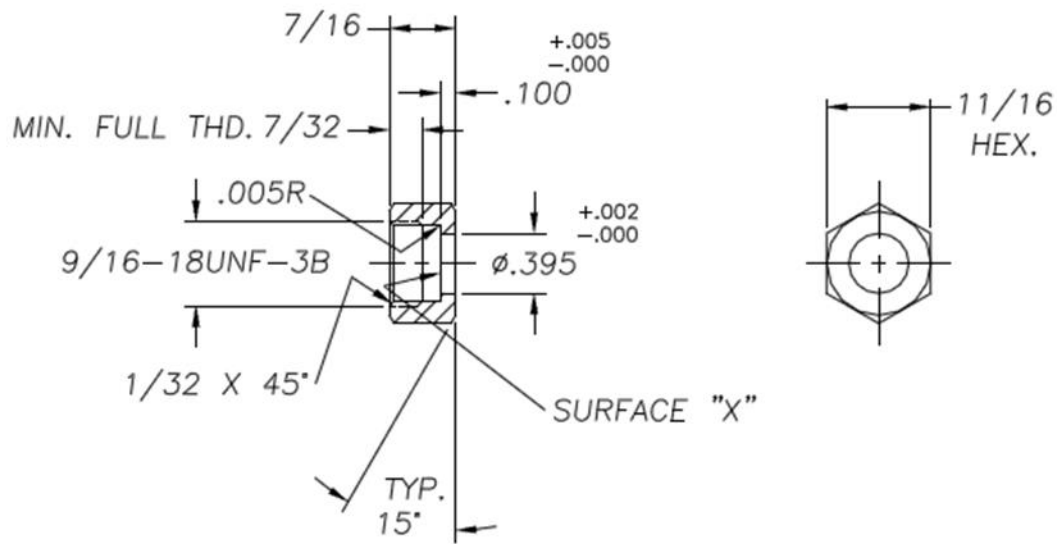

FIGURE 4. Tailpiece – heat recoverable.

MIL-DTL-24578C(SH)
W/AMENDMENT 1

NOTE:

1. $9/16$ THD. TO BE PERPENDICULAR WITH SURFACE "X" WITHIN $.003$ T.I.R.
2. $9/16$ THD. TO BE CONCENTRIC WITH $.395$ DIA WITHIN $.003$ T.I.R.

FIGURE 5. Union nut.

MIL-DTL-24578C(SH)
W/AMENDMENT 1

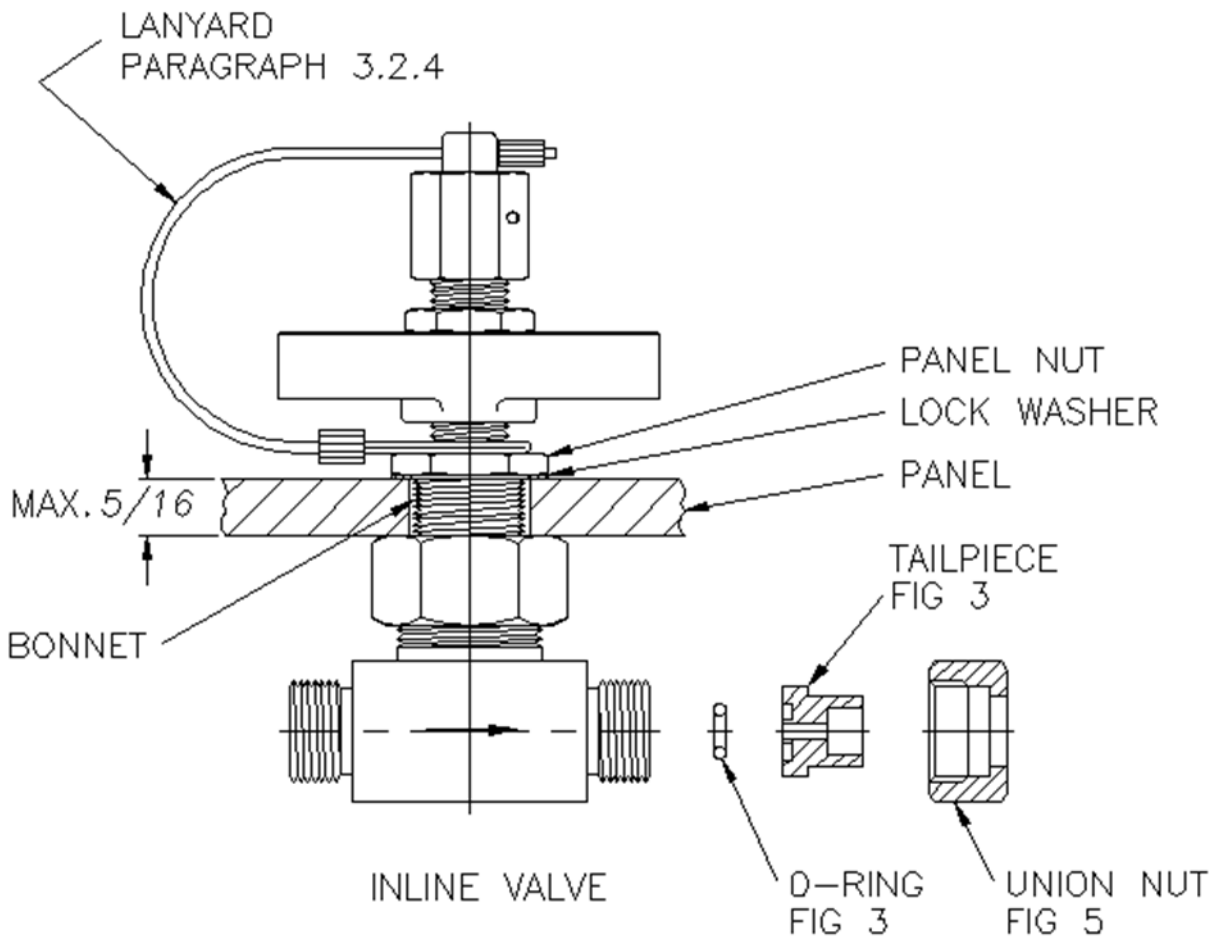

FIGURE 6. Typical assembly.

Review activity:
DLA – CC

Preparing activity:
Navy – SH
(Project 4820-2015-012)

NOTE: The activities listed above were interested in this document as of the date of this document. Since organizations and responsibilities can change, you should verify the currency of the information above using the ASSIST Online database at <https://assist.dla.mil>.