

**INCH-POUND**  
MIL-DTL-24347B  
w/ Amendment 2  
07 May 2008  

---

SUPERSEDING  
MIL-DTL-24347B  
w/ Amendment 1  
06 September 2002

## DETAIL SPECIFICATION

### MONITOR, AVAILABLE LOAD, 60 AND 400 HERTZ, A.C., 1 PHASE, ELECTRICAL POWER (NAVAL SHIPBOARD USE)

This specification is approved for use by all Departments and Agencies of the Department of Defense.

#### 1. SCOPE

1.1 Scope. This specification covers an available load monitor (ALM-2) to be used for sensing a load on either a 115 or 440 volt single phase circuit of either 60 or 400 hertz (Hz). ALM-2 is a direct replacement for ALM-1. ALM-1 is not to be procured for new constructions or replacement purposes.

#### 2. APPLICABLE DOCUMENTS

2.1 General. The documents listed in this section are specified in sections 3, 4 or 5 of this specification. This section does not include documents cited in other sections of this specification or recommended for additional information or as examples. While every effort has been made to ensure the completeness of this list, document users are cautioned that they must meet all specified requirements of documents cited in sections 3, 4 or 5 of this specification, whether or not they are listed.

##### 2.2 Government documents.

2.2.1 Specifications, standards, and handbooks. The following specifications, standards, and handbooks form a part of this document to the extent specified herein. Unless otherwise specified, the issues of these documents are those cited in the solicitation or contract (see 6 2).

#### DEPARTMENT OF DEFENSE SPECIFICATIONS

<a href="#">MIL-S-901</a>	- Shock Tests, H.I. (High-Impact); Shipboard Machinery, Equipment and Systems, Requirements for.
<a href="#">MIL-E-917</a>	- Electric Power Equipment, Basic Requirements.
<a href="#">MIL-E-2036</a>	- Enclosures for Electric and Electronic Equipment, Naval Shipboard.
<a href="#">MIL-DTL-15024</a>	- Plates, Tags and Bands for Identification of Equipment. General Specification for.
<a href="#">MIL-P-15024/5</a>	- Plates, Identification.
<a href="#">MIL-PRF-19500</a>	- Semiconductor Devices. General Specification for.

Comments, suggestions, or questions on this document should be addressed to: Defense Supply Center, Columbus, ATTN: DSCC-VAT, Post Office Box 3990, Columbus, Ohio 43218-3990 or by email [CircuitProtect@dla.mil](mailto:CircuitProtect@dla.mil). Since contact information can change, you may want to verify the currency of this address information using the ASSIST Online database at <http://assist.daps.dla.mil>.

MIL-DTL-24347B  
w/ Amendment 2

DEPARTMENT OF DEFENSE STANDARDS

- [MIL-STD-167-1A](#) - Mechanical Vibrations of Shipboard Equipment (Type I - Environmental and Type II - Internally Excited).
- [MIL-STD-461](#) - Requirements for the Control of Electromagnetic Interference Characteristics of Subsystems and Equipment.
- [MIL-STD-810](#) - Environmental Engineering Considerations and Laboratory Tests.
- [MIL-STD-1399-300A](#) - Interface Standard for Shipboard Systems Section 300A Electric Power, Alternating Current (Metric).

DEPARTMENT OF DEFENSE HANDBOOKS

- [MIL-HDBK-470](#) - Designing and Developing Maintainable Products and Systems, Volume I.
- [MIL-HDBK-781](#) - Reliability Test Methods, Plans, and Environments for Engineering Development, Qualification, and Production.

(Copies of these documents are available online at <http://assist.daps.dla.mil/quicksearch/> or <http://assist.daps.dla.mil> or from the Standardization Document Order Desk, 700 Robbins Avenue, Building 4D, Philadelphia, PA 19111-5094).

2.3 Order of precedence. Unless otherwise noted herein or in the contract, in the event of a conflict between the text of this document and the references cited herein, the text of this document takes precedence. Nothing in this document, however, supersedes applicable laws and regulations unless a specific exemption has been obtained.

### 3. REQUIREMENTS

3.1 First article. When specified (see 6.2), a sample shall be subjected to first article inspection (see 6.4) in accordance with 4.2.

3.2 General requirements. The enclosure and hardware material shall be of corrosion resistance material. The monitor fabricated of static components, shall be in accordance with MIL-E-917, and the requirements of this specification except as otherwise specified in the contract or order. If any requirement specified herein conflicts with the requirements of MIL-E-917, the requirements of this specification shall govern.

3.2.1 Pure tin. The use of pure tin, as an underplate or final finish, is prohibited both internally and externally. Tin content of the available load monitor components and solder shall not exceed 97 percent, by mass. Tin shall be alloyed with a minimum of 3 percent lead, by mass (see 6.7).

3.2.2 Painting. Parts not fabricated of a corrosion-resisting material or having a corrosion-resistant treatment as specified in MIL-E-917, except for semi-conductors, shall be painted as specified in MIL-E-917. One coat of gray enamel or epoxy shall be applied to the outside of the enclosure. Touching-up will be permitted for marks or scratches due to factory handling. Powder coat which meets the color requirement is permissible.

3.3 Definitions. Definitions shall be as specified in MIL-STD-1399-300A.

3.4 Performance. The single phase monitor shall perform the functions specified herein when connected in either a single or three phase main power circuit of either 115 or 440 normal voltage and either a 60 or 400 Hz normal frequency. The monitor shall operate within the specified limits when the voltage is reduced to 85 percent of normal or raised to 10 percent above normal. The operating frequency range shall be plus or minus 5 percent of normal. A typical monitor external wiring diagram is shown on figure 1. The monitor shall receive its voltage from the load side connections of the disconnect device. Under the above conditions, the monitor shall permit the load disconnect to close and stay latched if a load of 1-1/2 amperes (plus or minus 15 percent) exists. When the load current is reduced below 1-1/2 amperes (plus or minus 15 percent), the monitor shall actuate its normally open single contact static device to close and cause the disconnect device to open. Upon receipt of a signal, the contact shall have a delay adjustable from 5 seconds to 30 seconds before it operates. If current goes above 1-1/2 amperes before the set delay time, the monitor shall reset. The delay time shall be set at 15 seconds unless otherwise directed in the contract or order.

MIL-DTL-24347B  
w/ Amendment 2

3.4.1 Contact device. The static single contact device in the monitor is considered normally open when normal voltage and a load current of 1-1/2 amperes (plus or minus 15 percent) or more is available at the monitor. The normally open contact shall have a minimum continuous rating of 10 amperes, and intermittent rating of 15 amperes.

3.4.2 Input power. The monitor shall meet the performance requirements of 3.4 when powered in accordance with MIL-STD-1399-300A, types II and III.

3.5 Static components. Static components shall be in accordance with MIL-E-917. JAN, JANTX, JANTXV semiconductors in accordance with MIL-PRF-19500 are preferred. It is recommended that MIL-PRF-19500 be consulted for guidance when assessing the quality and reliability of controlled rectifiers, transistors and diodes. Field adjustment of the sensing circuits shall be provided to compensate for aging of components. Each monitor shall be provided with a toroid-type current sensing transformer as shown on figure 2 for external mounting on one wire connected on the load side of the disconnect device.

3.6 Trip duty. The monitor shall sense the load circuit continuously and shall permit the closing and tripping of the disconnect device continuously at 10-second intervals (see 4.5.6.1).

3.7 Enclosure. The enclosure shall be of dripproof or watertight construction in accordance with MIL-E-2036 (see 6.2), and as shown on figure 3. Holes of 1-1/16 inch diameter shall be placed in the two sides of the enclosure. The manufacturer shall recommend cable connectors that will ensure dripproof or watertight construction.

3.8 Internal components. Internal components shall be in accordance with MIL-E-917 and shall be mounted in an assembly which can be readily removed from the enclosure. The terminal board for connection of external wiring shall be marked as shown on figure 1. Printed circuit boards shall be conformal coated.

3.9 Ventilation. Ventilation shall be by natural draft.

3.10 Environmental.

3.10.1 Ambient temperature. The normal ambient temperature shall be 50 degrees Celsius (°C). The monitor shall meet the specification requirements when operating in an ambient temperature from 0 to 65°C.

3.10.2 Humidity. The monitor shall meet the requirements specified herein when exposed to an ambient humidity within the humidity range specified in MIL-STD-810 (see 4.5.14).

3.11 Mounting. The monitor shall comply with the mounting dimensions shown on figure 3. Dimensions for the monitor current sensing transformer shall be as shown on figure 2 and shall meet the mounting requirements specified in 3.5.

3.12 Weight. The weight of the monitor and its separate sensing transformer shall be held to a maximum of 4.0 pounds.

3.13 Insulation resistance. The insulation resistance of all circuits shall be not less than 10 megohms (see 4.5.3).

3.14 Dielectric strength. The monitor shall withstand, for 1 minute, a dielectric test voltage between separate circuits and to ground as follows (see 4.5.11):

<u>Ac ((rms) input or output voltage)</u>	<u>Test voltage (rms)</u>
60 and under	600
61 to 90	900
91 to 600	1000 plus twice rated
Over 600	2000 plus 2-1/4 times rated

MIL-DTL-24347B  
w/ Amendment 2

## ALL CONNECTING WIRING OF 2828CM

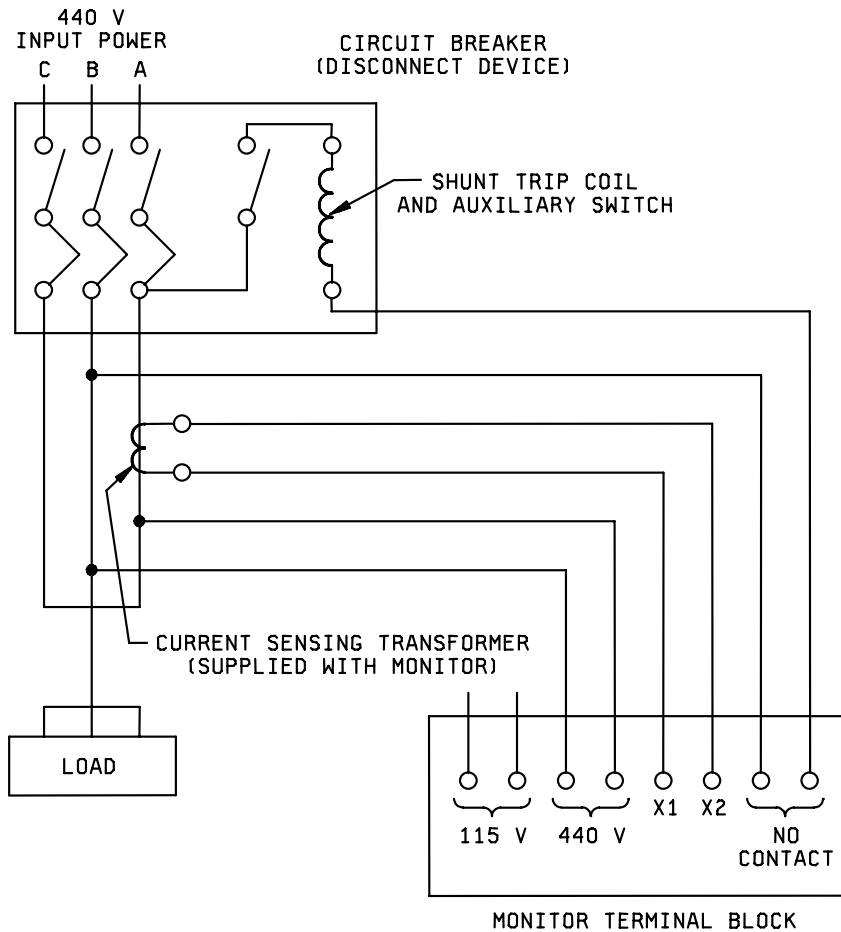

Typical wiring shown for monitor when connected to a circuit breaker with shunt trip coil on a 440 volt circuit. Monitor normally open static contact is rated at a minimum of 10 amperes continuous, and intermittent rating of 15 amperes.

In each application the 115 volt - 115 volt or 440 volt - 440 volt terminals, as applicable, shall be connected to the load side of the main circuit disconnect device.

FIGURE 1A. Typical external wiring connections to monitor for shunt trip application.

MIL-DTL-24347B  
w/ Amendment 2

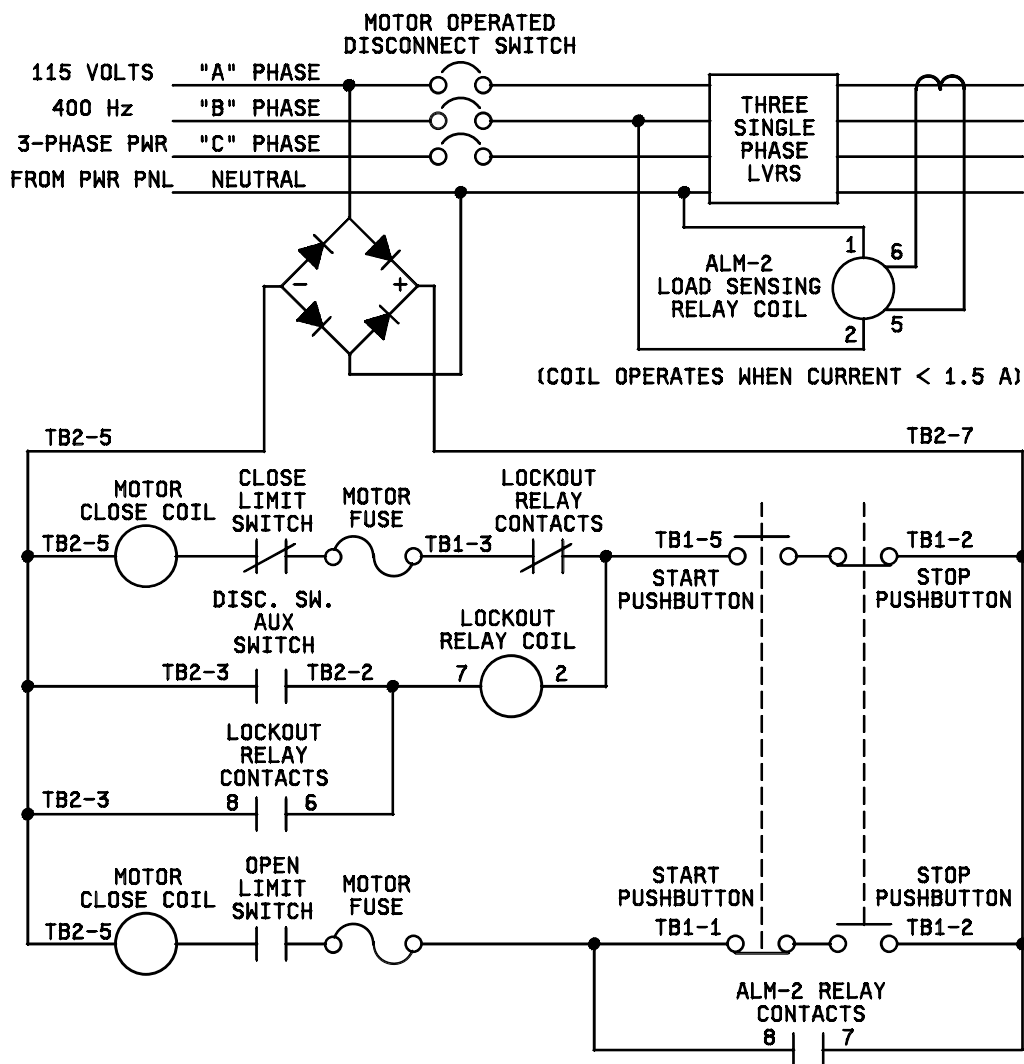

Typical wiring shown for monitor when connected to a circuit breaker with motor operator on a 115 volt circuit. Monitor normally open static contact is rated at a minimum of 10 amperes continuous, and intermittent rating of 15 amperes.

In each application the 115 volt - 115 volt or 440 volt - 440 volt terminals, as applicable, shall be connected to the load side of the main circuit disconnect device.

Figure 1B. Typical external wiring connections to monitor for motor operated circuit breaker application.

MIL-DTL-24347B  
w/ Amendment 2

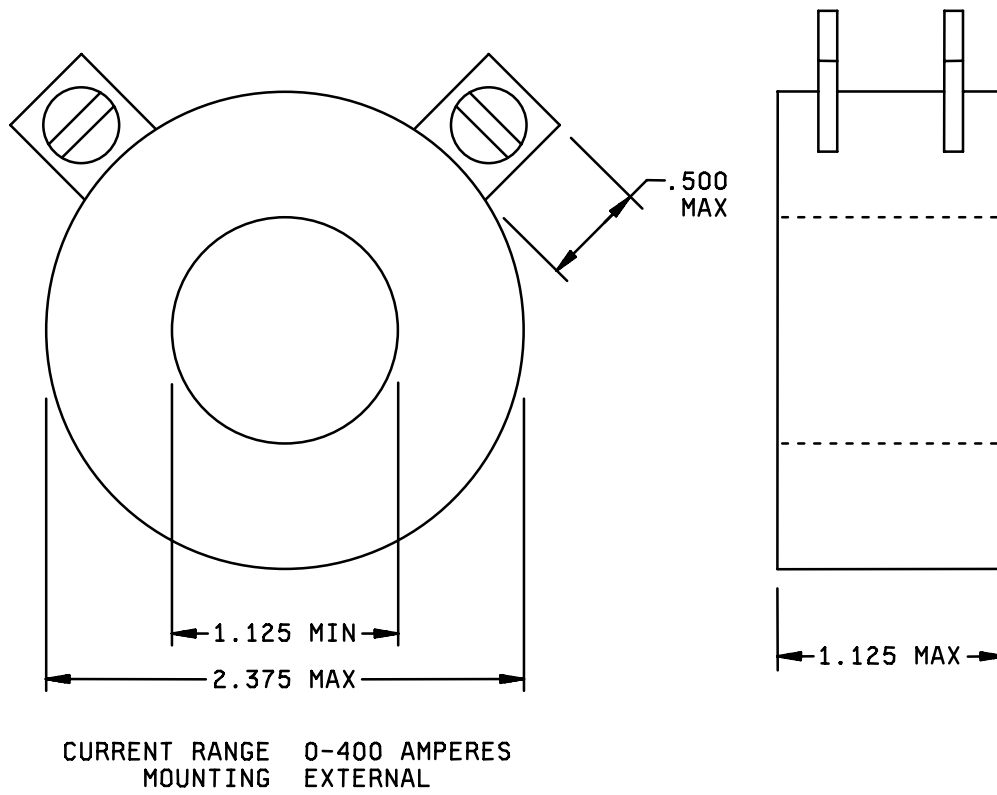

FIGURE 2. Outline dimensions for monitor current sensing transformer.

MIL-DTL-24347B  
w/ Amendment 2

3.15 Vibration. The monitor shall withstand vibration in accordance with type I of MIL-STD-167-1A without mechanical damage or malfunctioning (see 4.5.12).

3.16 Shock. The monitor shall withstand shock specified in MIL-S-901 for light weight equipment without the use of shock mounts. With rated voltage applied all devices shall function properly during and after the shock test (see 4.5.15). Mounting fixture 4A in accordance with MIL-S-901 shall apply.

3.17 Interference. The monitor shall meet the interference limits as specified in MIL-STD-461 (see 4.5.8).

3.18 Inclined operation. The monitor shall show no change in operation when inclined at an angle of 45 degrees from the vertical in any direction (see 4.5.7).

3.19 Warm -up. The monitor shall meet the performance requirement specified herein after being energized for a maximum of 1 minute (see 4.5.5).

3.20 Reliability. The upper test mean time between failure (MTBF) for continuous and intermittent operation shall be 40,000 hours, under the environmental conditions specified for the monitor, when tested in accordance with 4.5.10. It is recommended that MIL-HDBK-781 be used as guidance in accomplishing this testing. A failure (as used herein) shall be as specified in 4.5.16.

3.21 Maintainability. The monitor shall facilitate trouble-shooting, fault isolation, and repair down to the lowest nonrepairable part or nonrepairable assembly (see 4.5.10).

3.22 Interchangeability. In no case shall parts be physically interchangeable or reversible unless such parts are also interchangeable or reversible with regard to function, performance and strength.

3.23 Connection diagram and identification plates. Plates shall be in accordance with MIL-DTL-15024 and MIL-P-15024/5. The plates shall be brass or corrosion-resistant steel of not less than 0.030 inch in thickness and marked by etching, engraving, stamping or photoprocess. The marking shall be not less than 0.003 inch deep.

3.23.1 Connection diagram plate. Each monitor shall be provided with a connection diagram plate mounted on the inside surface of the front cover. The plate shall contain the data shown on figure 1.

3.23.2 Identification plate. Each monitor shall be provided with an identification plate mounted on the outside of the front cover. The identification plate for the complete equipment assembly shall indicate the following data:

MONITOR: AVAILABLE LOAD VOLTAGE: 115-400 PH.1 AC  
 ALM-2: ALM-Q FREQ: 60-400 DUTY: CONT. AMB.: 50°C  
 CONTACT: NORMALLY OPEN UNDER LOAD CONTACT RATING: minimum 10 AMP. CONT.  
 CLOSING LOAD: 1-1/2 AMPS. OPENING LOAD: LESS 1-1/2 AMPS.  
 CAT. NO. \_\_\_\_\_ SER NO. \_\_\_\_\_ YEAR \_\_\_\_\_  
 STK. NO. \_\_\_\_\_ CONTRACT \_\_\_\_\_ NAVSHIPS 0963- \_\_\_\_\_  
 MANUFACTURER'S NAME AND ADDRESS

3.23.3 Component identification. Components shall be identified by stamping or stenciling the data immediately adjacent to the component.

3.24 Provisioning. See 6.5.

3.25 Recycled, recovered, or environmentally preferable materials. Recycled, recovered, or environmentally preferable materials should be used to the maximum extent possible provided that the material meets or exceeds the operational and maintenance requirements, and promotes economically advantageous life cycle costs.

MIL-DTL-24347B  
w/ Amendment 2

3.26 Workmanship. Metal surfaces shall have a smooth finish and all details of manufacture, including the preparation of parts and accessories, shall be in accordance with the best practice for high quality electrical equipment. Particular attention shall be given to neatness and thoroughness of soldering, wiring, impregnation of coils, marking of parts, plating, lacquering, riveting, clearance between connections, ruggedness, and suitability of enclosure.

## 4. VERIFICATION

4.1 Classification of inspections. The inspection requirements specified herein are classified as follows:

- a. First article inspection (see 4.2).
- b. Conformance inspection (see 4.3).

4.2 First article inspection. First article inspection shall consist of the examination and tests specified in [table I](#) (see 6.4).

4.2.1 First article sample. The first article sample shall be one monitor of each type.

4.3 Conformance inspection.

4.3.1 Inspection of product for delivery. Each production monitor shall be subjected to the conformance inspection specified in [table I](#).

4.3.2 Periodic inspection. Two years after first article inspection and after each two years in which the monitor is offered for delivery thereafter, one monitor shall be subjected to the periodic inspection specified in [table I](#).

4.4 Examination. Each monitor shall be examined to determine compliance with the workmanship requirements of 3.26.

4.5 Test procedures. Unless otherwise specified herein, all tests requiring electrical loading of equipment shall normally be performed using a resistive load for uniformity and convenience.

4.5.1 Effectiveness of enclosure. The equipment enclosure shall be tested in accordance with [MIL-E-2036](#) for dripproof and watertight requirements. Dripproof and watertight enclosures shall be accepted or rejected based on inspection to ascertain that the enclosure effectively performs its specified function (see [figure 3](#)). External wiring connections shall be made to the unit.

4.5.2 Creepage and clearance. Creepage and clearance distances shall be demonstrated by actual measurement in accordance with [MIL-E-917](#).

4.5.3 Insulation resistance. Insulation resistance shall be as specified in 3.13. The measurement of insulation resistance shall be made with all circuits of different voltage above ground connected together. Circuits or groups of circuits of equal voltage shall be tested separately. Insulation resistance shall be measured with an insulation-resistance-indicating meter at 500 volts dc. The time of test voltage application shall be not less than 60 seconds. Measurements shall be made at any convenient ambient temperature with all circuits cold. The relative humidity and ambient temperature shall be recorded. The monitor shall not be damaged when the main shipboard power circuit cables are being tested between phases or between phase and ground with the 500-volt dc tester.

4.5.4 Wiring. The connecting voltage leads and current sensing leads to the monitor shall be individually subjected to open circuit and grounded to determine that no damage occurs to the monitor.

4.5.5 Warm-up. When the monitor is subjected to nominal voltage and frequency at both 0°C and 65°C ambient the equipment shall meet the requirements of 3.20.



MIL-DTL-24347B  
w/ Amendment 2

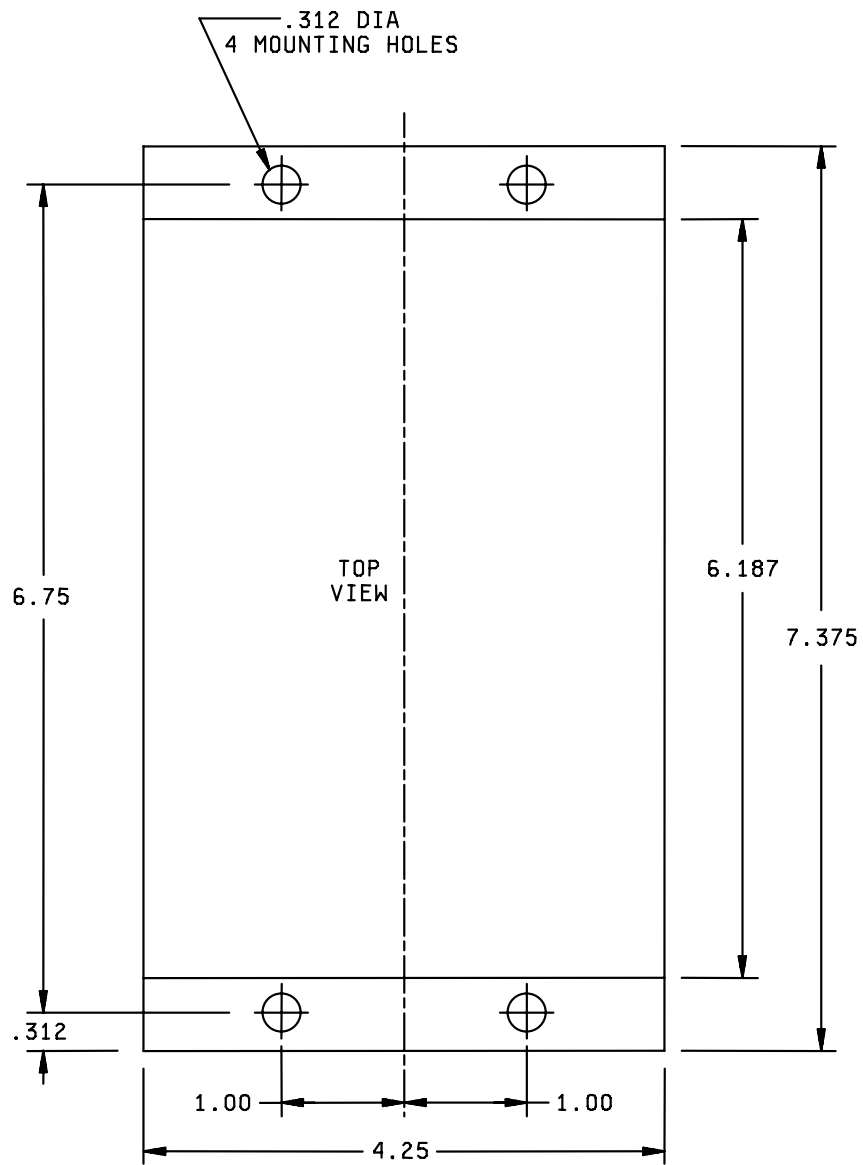

4 INCHES OVERALL DEPTH OF ENCLOSURE-(MAX).

FIGURE 3. Monitor outline and mounting dimensions.

MIL-DTL-24347B  
w/ Amendment 2TABLE I. First article, conformance and periodic inspection.

Inspection	First article inspection	Conformance inspection	Periodic Inspection	Requirement	Inspection
General examination	X	X	X	3.26	4.4
Effectiveness of enclosure	X	N/A	N/A	3.7	4.5.1
Creepage and clearance	X	N/A	X	3.2	4.5.2
Insulation resistance	X	N/A	X	3.13	4.5.3
Wiring	X	N/A	X	3.4	4.5.4
Warm-up	X	N/A	X	3.19	4.5.5
Performance	X	X	X	3.4	4.5.6
Trip duty	X	N/A	X	3.6	4.5.6.1
Inclined operation	X	N/A	X	3.18	4.5.7
Interference	X	N/A	N/A	3.17	4.5.8
Reliability	X	N/A	N/A	3.20	4.5.9
Maintainability	X	N/A	N/A	3.21	4.5.10
Dielectric strength	X	X	X	3.14	4.5.11
Vibration	X	N/A	N/A	3.15	4.5.12
Voltage surge	X	N/A	X	3.4.2	4.5.13
Humidity	X	N/A	N/A	3.10.2	4.5.14
Shock	X	N/A	X	3.16	4.5.15

4.5.6 Performance. The monitor connection wiring diagram shown on [figure 1A](#) shall be used for this testing (see [3.4](#)). The monitor tests shall be performed with each circuit breaker having a shunt trip and also a remote control switch. The opening coils of the above disconnect devices shall have a resistance from 15 to 400 ohms. The single phase monitor shall perform the functions specified herein when connected in either a single or three phase main power circuit of either 115 or 440 normal voltage and either a 60 or 400 Hz normal frequency. The monitor shall operate satisfactorily within the specified limits when the voltage is reduced to 85 percent of normal or raised to 10 percent above normal. The operating frequency range shall be plus or minus 5 percent of normal. The monitor shall perform satisfactorily when two cables are connected in parallel to form one leg of the load circuit and the current sensing transformer is placed around one cable only which has an available current of 1-1/2 amperes (plus or minus 15 percent) or more. Under the above conditions the monitor shall permit the load disconnect device to close and stay latched if a load of 1-1/2 amperes (plus or minus 15 percent) or more exists. When the above load is removed, the monitor shall actuate its normally open static contact to a closed position and cause the load disconnect device to open. The static normally open contact in the monitor shall have a minimum 10-ampere continuous current carrying rating. The tests shall be performed over an ambient temperature range as specified in [3.10.1](#). The same monitor is then in accordance with connection wiring diagram 1B, testing shall be repeated to demonstrate the ALM output is capable to open the 250 ampere Navy Standard AQB type breakers via the motor operator under the same test condition.

4.5.6.1 Performance latch and trip. During the testing of [4.5.6](#), it shall be demonstrated that the monitor has latched and tripped the associated disconnect device or open the circuit breaker via motor operator for at least 40 cycles of operation (see [3.6](#)).

4.5.6.2 Reset. During the performance test, the available current shall be increased to 1-1/2 amperes. The current shall then be reduced to less than 1-1/2 amperes before the delay time is reached and the monitor sends a trip signal. The monitor shall reset.

4.5.7 Inclined operation. The monitor shall be tested for inclined operation at rated voltage and frequency. Inclination of the monitor in the following positions shall not affect the performance requirements of [3.4](#) and [3.18](#):

- a. Inclined 45 degrees forward.
- b. Inclined 45 degrees backward.
- c. Inclined 45 degrees to the right side.
- d. Inclined 45 degrees to the left side.

MIL-DTL-24347B  
w/ Amendment 2

4.5.8 Interference (see 3.17). The monitor shall meet the requirements of MIL-STD-461 for conducted and radiated susceptibility and radiated emissions as applicable for its intended use.

4.5.9 Reliability. Reliability tests shall be as follows:

4.5.9.1 Demonstration phase. Unless otherwise specified (see 6.2), the demonstration phase of reliability testing shall be conducted on at least 5 (but not more than 10) monitors. It is recommended that test plan IIID of MIL-HDBK-781 be used as guidance in performing this testing. The upper test MTBF shall be as specified in 3.20.

4.5.9.2 Test schedule. The test shall consist of an uninterrupted series of three 8-hour periods per day. One of the three periods shall be manned. The remaining two periods need not be manned.

4.5.9.3 Stress conditions. Unless otherwise specified below or in the contract or order (see 6.2), it is recommended that the environmental and electrical stress conditions noted under the combined environments for shipboard and underwater vehicle equipments in MIL-HDBK-781 be used as guidance for this testing.

a. Electrical stress: When operation from two or more nominal voltages is required, the nominal voltage for reliability testing shall be the highest required nominal voltage.

b. Thermal stress: The test time for each thermal cycle shall be 8 hours.

4.5.9.4 Sampling phase. When specified (see 6.2), the sampling phase of reliability testing shall be conducted on at least 5 (but not more than 10) monitors. It is recommended that test plan IVD of MIL-HDBK-781 be used as guidance in performing this testing. The upper test MTBF shall be as specified in 3.20. The test schedule and stress conditions of 4.5.9.2 and 4.5.9.3 shall apply.

4.5.10 Maintainability demonstration. When specified (see 6.2), conformance to 3.21 shall be verified through a maintenance demonstration procedure, maintenance task selection, and maintenance task performance. It is recommended that MIL-HDBK-470 be used as guidance in performing this demonstration.

4.5.11 Dielectric strength.

4.5.11.1 General. The dielectric strength test shall be conducted following completion of the tests specified in 4.5.1 through 4.5.9. the dielectric test shall be made upon the completely assembled equipment and not upon individual parts (see 6.5).

4.5.11.2 Test voltage. The frequency of the testing voltage shall be not less than 60 Hz and shall approximate a true sine wave. The value of test voltage shall be as specified in 3.14 and shall be applied continuously for 1 minute. Rectifiers, bridges and zener references shall be shorted out before applying the voltage.

4.5.11.3 Measurement of test voltage. The measurement of the voltage used in dielectric tests shall be made by the voltmeter method whereby the meter derives its voltage from the high-voltage circuit either directly or by means of a voltmeter coil placed in the testing transformer, or through an auxiliary ratio transformer.

4.5.11.4 Points of application. The test voltage shall be successively applied between each electric circuit, and all other electrical circuits and grounded metal parts not electrically connected to it.

4.5.12 Vibration. Equipment shall be subjected to type I vibration tests in accordance with MIL-STD-167-1A, when energized at approximately nominal voltage and frequency (see 3.15).

4.5.13 Voltage surge. The indicator shall be subjected to an impulse test of 450 volts with spikes to 2500 volts in accordance with MIL-STD-1399-300A.

4.5.14 Humidity. Humidity tests shall be in accordance with method 507.4, of MIL-STD-810.

4.5.15 Shock. Shock tests shall be conducted in accordance with MIL-S-901 for grade A, class I equipment (see 3.16). After the shock tests, the equipment shall be spot checked for the specified operation (see 3.4).

MIL-DTL-24347B  
w/ Amendment 2

4.5.15.1 Disposition. If a monitor passes the shock test, it may be furnished as an item under the contract or order after correction of possible minor damage and touch up of paint.

4.5.16 Nonconformance. For acceptance, the monitor shall be as follows:

- a. Breakage or appreciable distortions shall not occur for any parts.
- b. Electrical malfunction. The sensing features shall not malfunction, become inoperative or deviate from specifications.
- c. Insulation resistance shall not vary from its original value.

4.6 Inspection of packaging. Sample stowage packs, and the inspection of the preservation-packing and marking for shipment and storage shall be in accordance with the requirements of section 5 and the documents specified therein.

## 5. PACKAGING

5.1 Packaging. For acquisition purposes, the packaging requirements shall be as specified in the contract or order (see 6.2). When packaging of materiel is to be performed by DoD or in-house contractor personnel, these personnel need to contact the responsible packaging activity to ascertain packaging requirements. Packaging requirements are maintained by the Inventory Control Point's packaging activities within the Military Service or Defense Agency, or within the military service's system commands. Packaging data retrieval is available from the managing Military Department's or Defense Agency's automated packaging files, CD-ROM products, or by contacting the responsible packaging activity.

## 6. NOTES

(This section contains information of a general or explanatory nature that may be helpful, but is not mandatory.)

6.1 Intended use. The monitor is intended for use to sense a power circuit and permit the closing and latching of the associated disconnect device if a load in the specified range exists. When the load is removed for a period of time exceeding the preset delay interval, the monitor should signal the disconnect device to open.

6.2 Acquisition requirements. Procurement documents should specify the following:

- a. Title, number, and date of the specification.
- b. ASSIST Online database should be cited in the solicitation, and if required, the specific issue of individual documents referenced. If not otherwise specified, the versions of the individual documents referenced will be those in effect on the date of release of the solicitation (see 2.).
- c. When first article is required (see 3.1).
- d. Whether dripproof or watertight enclosures are required (see 3.7).
- e. Conditions for reliability tests, if other than specified herein (see 4.5.9).
- f. Whether maintainability demonstration is required (see 4.5.10).
- g. When fire-retardant treated materials are not required (see 5.1)
- h. Level of preservation, packing and marking required (see 5.1).
- i. Packaging requirements (see 5.1).

MIL-DTL-24347B  
w/ Amendment 2

6.3 Technical manuals. The requirement for technical manuals should be considered when this specification is applied on a contract. If technical manuals are required they must be listed on a separate Contract Data Requirements List (DD Form 1423), which is included as an exhibit to the contract. The technical manuals must be acquired under separate contract line item in the contract.

6.4 First article. When first article inspection is required, the contracting officer should provide specific guidance to offerors whether the items should be a first article sample and the number of items to be tested as specified in 4.2. The contracting officer should also include specific instructions in acquisition documents regarding arrangements for examinations, approval of first article test results, and disposition of first articles. Invitations for bids should provide that the Government reserves the right to waive the requirement for samples for first article inspection to those bidders offering a product which has been previously acquired or tested by the Government, and that bidders offering such products, who wish to rely on such production or test, must furnish evidence with the bid that prior Government approval is presently appropriate for the pending contract. Bidders should not submit alternate bids unless specifically requested to do so in the solicitation.

6.5 Provisioning. Spare parts, and repair parts should be furnished as specified in the contract. When ordering spare parts or repair parts, the contract should state that such spare parts and repair parts should meet the same requirements as the parts used in the manufacture of the equipment. Packaging for such parts should also be specified.

6.6 Sub-contractor material and parts. The packaging requirements of referenced documents listed in section 2 do not apply when material and parts are acquired by the contractor for incorporation into the equipment and lose their separate identity when the equipment is shipped.

6.7 Tin whisker growth. The use of alloys with tin content greater than 97 percent, by mass, may exhibit tin whisker growth problems after manufacture. Tin whiskers may occur anytime from a day to years after manufacture and can develop under typical operating conditions, on products that use such materials. Conformal coatings applied over top of a whisker-prone surface will not prevent the formation of tin whiskers. Alloys of 3 percent lead, by mass, have shown to inhibit the growth of tin whiskers. For additional information on this matter, refer to [ASTM-B545](#) (Standard Specification for Electrodeposited Coatings of Tin).

6.8 Environmentally preferable material. Environmentally preferable materials should be used to the maximum extent possible to meet the requirements of this specification. As of the dating of this document, the U.S. Environmentally Protection Agency (EPA) is focusing efforts on reducing 31 priority chemicals. The list of chemicals is available on their website at <http://www.epa.gov/epaoswer/hazwaste/minimize/chemlist.htm>. Further information is available at the following EPA site: <http://www.epa.gov/epaoswer/hazwaste/minimize/>. Included in the EPA list of 31 priority chemicals are cadmium, lead, and mercury. Use of the materials on the list should be minimized or eliminated unless needed to meet the requirements specified herein (see Section 3).

6.9 Subject term (key word) listing.

Contact device  
Dripproof  
Enclosure  
Watertight

6.10 Amendment notations. The margins of this specification are marked with vertical lines to indicate modifications generated by this amendment. This was done as a convenience only and the Government assumes no liability whatsoever for any inaccuracies in these notations. Bidders and contractors are cautioned to evaluate the requirements of this document based on the entire content irrespective of the marginal notations.

MIL-DTL-24347B  
w/ Amendment 2

Custodians:  
Navy - SH  
DLA - CC

Preparing activity:  
DLA - CC  
  
(Project 5925-2007-007)

NOTE: the activities listed above were interested in this document as of the date of this document. Since organizations and responsibilities can change, you should verify the currency of the information above using the ASSIST Online database at <http://assist.daps.dla.mil>.