

INCH-POUND

MIL-DTL-22641D  
31 January 2000  
SUPERSEDING  
MIL-A-22641C  
27 July 1972

## DETAIL SPECIFICATION

ADAPTERS, COAXIAL TO WAVEGUIDE,  
GENERAL SPECIFICATION FOR

This specification is approved for use by all Departments and Agencies of the Department of Defense.

## 1. SCOPE

1.1 Scope. This specification covers the general requirements for adapters that connect series N connectors to waveguides, 5/8-inch coaxial lines to waveguides, and 7/8-inch coaxial lines to waveguides, series TNC connectors to waveguides, and series SMA connectors to waveguides, for general application by the armed services (see 6.1, 6.2.1 and 6.6).

1.2 Classification. For the purpose of this specification, adapters are classed as follows (see 3.1):

- Class 1 - Coaxial, series N to waveguides.
- Class 2 - 5/8-inch coaxial lines to waveguides.
- Class 3 - 7/8-inch coaxial lines to waveguides.
- Class 4 - Coaxial, series TNC to waveguides.
- Class 5 - Coaxial, series SMA to waveguides.

## 2. APPLICABLE DOCUMENTS

2.1 General. The documents listed in this section are specified in sections 3 and 4 of this specification. This section does not include documents cited in other sections of this specification or recommended for additional information or as examples. While every effort has been made to ensure the completeness of this list, document users are cautioned that they must meet all specified requirements documents cited in sections 3 and 4 of this specification, whether or not they are listed.

2.2 Government documents.

2.2.1. Specifications, standards and handbooks. The following specifications, standards and handbooks form a part of this document to the extent specified herein. Unless otherwise specified, the issues of these documents are those listed in the issue of the Department of Defense Index of Specifications and Standards (DODISS) and supplement thereto, cited in the solicitation (see 6.2).

## SPECIFICATIONS

## FEDERAL

QQ-B-654 - Brazing Alloys, Silver.

## DEPARTMENT OF DEFENSE

MIL-DTL-85 - Waveguides, Rigid, Rectangular, General Specification for.  
MIL-F-3922 - Flanges, Waveguide, General Purpose, General Specification for.  
MIL-C-5541 - Chemical Conversion Coatings on Aluminum and Aluminum Alloys.  
MIL-F-14072 - Finishes for Ground Based Electronic Equipment.  
MIL-DTL-15090 - Enamel, Equipment, Light Gray (Navy Formula No. 111).  
MIL-PRF-39012 - Connectors, Coaxial, Radio Frequency, General Specification for.  
MIL-DTL-22641/16 - Adapters, Coaxial to Waveguide (Series N to Waveguide - Class I).  
MIL-DTL-22641/20 - Adapters, Coaxial to Waveguide (Series SMA to Waveguide - Class 5).

Beneficial comments (recommendations, additions, deletions) and pertinent data of use in improving this document should be addressed to: Defense Supply Center Columbus, ATTN: DSCC-VAT, P.O. BOX 3990, Columbus, OH 43216-5000, by using the self-addressed Standardization Document Improvement Proposal (DD Form 1426) at the end of this document or by letter.

## MIL-DTL-22641D

## STANDARDS

## FEDERAL

FED-STD-H28 - Screw-Thread Standards for Federal Services.

## DEPARTMENT OF DEFENSE

MIL-STD-130 - Identification Marking of U.S. Military Property.  
MIL-STD-202 - Test Method Standard for Electronic and Electrical Component Parts.

(Unless otherwise indicated, copies of the above specifications and standards are available from the Standardization Document Order Desk, 700 Robbins Avenue, Building 4D, Philadelphia, PA 19111-5094.)

2.3 Non-Government publications. The following documents form a part of this document to the extent specified herein. Unless otherwise specified, the issues of the documents which are DoD adopted are those listed in the issue of the DODISS cited in the solicitation. Unless otherwise specified, the issues of documents not listed in the DODISS are the issues of the documents cited in the solicitation (see 6.2).

## AMERICAN NATIONAL STANDARDS INSTITUTE (ANSI)

ANSI-Z540.1-94 - Laboratories, Calibration, and Measuring and Test Equipment (DoD adopted).

(Application for copies should be addressed to the American National Standards Institute, Sales and Service, 11 West 42<sup>nd</sup> Street, New York, NY 10036.)

## INSTITUTE FOR INTERCONNECTING AND PACKAGING ELECTRONIC CIRCUITS (IPC)

IPC-J-STD-004 - Requirements for Soldering Fluxes (DoD adopted).  
IPC-J-STD-005 - Requirements for Soldering Pastes (DoD adopted).  
IPC-J-STD-006 - Requirements for Electronic Grade Solder Alloys and Fluxed and Non-Fluxed Solid Solders for Electronic Soldering Applications (DoD adopted).

(Application for copies should be directed to the Institute for Interconnecting and Packaging Electronic Circuits, 2215 Sanders Rd., Suite 200 South, Northbrook, IL 60062.)

2.4 Order of precedence. In the event of a conflict between the text of this document and the references cited herein (except for related specification sheets), the text of this document takes precedence. Nothing in this document, however, supersedes applicable laws and regulations unless a specific exemption has been obtained.

## 3. REQUIREMENTS

3.1 Specification sheets. The individual item requirements shall be as specified herein and shall be in accordance with the applicable specification sheets (see 2.2.1). In the event of any conflict between the requirements of this specification and the specification sheet, the latter shall govern.

3.1.1 First Article. Adapters furnished under this specification shall be products that have been tested and have passed the first article inspection specified in 4.4.

3.1.2 Design and construction. Adapters shall be of the design, construction, and overall physical dimensions specified, and shall be capable of adapting the specified waveguide to the specified coaxial line (see 3.1).

3.2 Material. The material shall be as specified in the specification sheet (see 3.1). When a definite material is not specified, a material shall be used which will enable the adapters to meet the performance requirements of this specification. Acceptance or approval of any constituent material shall not be construed as a guaranty of the acceptance of the finished product.

3.2.1 Metal parts. All metal parts shall be free from chips, burrs, and scratches in accordance with good commercial practice. Electrical conducting brass parts shall be silver-plated not less than 0.0003-inch thick and then rhodium flashed. The internal surfaces of all aluminum adapters shall be chemically treated in accordance with MIL-C-5541.

3.2.1.1 Dissimilar metals. Unless suitably protected against electrolytic corrosion, dissimilar metals shall not be used in contact with each other (see 6.4.1).

## MIL-DTL-22641D

3.2.2 Plastic Parts. All plastic parts shall be free from visible cracks or flaws.

3.2.2.1 Plastic caps. The waveguide flange and RF connector ends of the adapter are to be sealed with push-on plastic caps to prevent damage and to prevent the entrance of moisture and foreign material during storage.

3.2.3 Threaded parts. All threaded parts shall be in accordance with FED-STD-H28.

3.2.4 Connectors. Connector for a specified adapter shall be as specified (see 3.1). Materials, design, and construction of the connectors shall conform to MIL-PRF-39012.

3.2.5 Waveguide flange. The waveguide flange used with each adapter shall properly mate with the flange specified (see 3.1), which shall conform to MIL-F-3922.

3.2.5.1 Mating. No constructional detail of the adapters shall interfere with mating of the waveguide flange with its counterpart.

3.2.6 Waveguide. The waveguide used with each adapter shall be of the type specified (see 3.1), and shall conform to MIL-DTL-85.

3.2.6.1 Positioning of the coaxial extension. The coaxial extension of each adapter shall be positioned on the waveguide so that all the electrical requirements are satisfied; however, since there are multiples of the satisfactory electrical lengths from the end plate which will also satisfy the requirements, the distance from the end plate to the coaxial extension shall be chosen as the shortest length possible.

3.2.7 Angular alignment. In assembling flanges to a section of waveguide, 1 inch by 0.5 inch and larger sizes, the flange face shall make an angle of 90 degrees  $\pm$  30 minutes with the E- and H-plane of the internal surfaces of the waveguide; for smaller sizes, the flange face shall make an angle of 90 degrees  $\pm$  15 minutes.

3.2.8 Brazed or welded joints. When a sleeve flange is attached to a waveguide by a weld or braze, the flange face shall be machined smooth and shall show no sign of pits, air pockets, or other surface irregularities.

3.2.9 Soldered joints. All joints shall be silver soldered except that the end plate may be soft soldered. The silver solder shall conform to QQ-B-654. The soft solder shall conform to composition SN-60 of IPC J-STD-004, IPC J-STD-005, and IPC J-STD-006. All soldered joints shall be thoroughly cleaned to avoid corrosion.

3.2.10 Finish. All exterior surfaces of the adapter, except the mating surface, shall be finished in accordance with finish number P511, type I of MIL-F-14072 for aluminum alloy adapters, and finish number P213, type I of MIL-F-14072 for copper alloy adapters, with final film E of MIL-F-14072 conforming to type III, class 2, of MIL-DTL-15090.

3.3 Recycled, recovered, or environmentally preferable materials. Recycled, recovered, or environmentally preferable materials should be used to the maximum extent possible provided that the material meets or exceeds the operational and maintenance requirements, and promotes economically advantageous life cycle costs. All components supplied shall be new and unused.

3.4 Voltage standing wave ratio (VSWR). When adapters are tested as specified in 4.6.2 and 4.6.2.1, the voltage standing wave ratio shall not exceed the values specified (see 3.1).

3.5 RF insertion loss (when specified, see 3.1). When adapters are tested as specified in 4.6.3, the insertion loss shall not exceed that specified (see 3.1).

3.6 Pressurization. When adapters are tested as specified in 4.6.4, there shall be no leakage, as detected by the continuous formation of escaping air bubbles. Air leakage through the RF connector is not acceptable.

3.7 Shock (specified pulse). When adapters are tested as specified in 4.6.5, the VSWR and RF insertion loss shall be as specified (see 3.1).

3.8 Vibration. When adapters are tested as specified in 4.6.6, the VSWR and RF insertion loss shall be as specified (see 3.1), and the pressurization shall be as specified in 3.6.

3.9 Salt spray (corrosion). When adapters are tested as specified in 4.6.7, there shall be no destructive corrosion or pitting. Destructive corrosion is any type of corrosion which in any way interferes with mechanical or electrical performance of the adapter.

3.10 Dielectric withstanding voltage (coaxial end). When adapters are tested as specified in 4.6.8, there shall be no evidence of breakdown.

3.11 Gauge. Adapters shall withstand the gauge test specified in 4.6.9, as specified for the applicable class.

## MIL-DTL-22641D

3.12 Marking. Flanges shall be marked in accordance with MIL-STD-130, with the part or identifying number (see 3.1 and 6.2.1) and the manufacturer's code symbol. The end plate shall include the frequency band, RF insertion loss, and VSWR of the particular adapter (see 3.1). All markings shall withstand normal abuse and be legible for the life of the adapter. The height of the part or identifying number shall be appropriately sized to correspond with the area to be marked (from .125 inch to .250 inch, if part marking area permits), with an absolute minimum of .03125 inch high characters in all cases. The PIN shall be comparable in height to the manufacturer's name or code symbol. Marking shall be applied directly on the adapter in the location specified (see 3.1).

3.13 Workmanship. Adapters shall be processed in such a manner as to be uniform in quality, and all surfaces shall be free from pits, corrosion, cracks, rough edges, chips, burrs, scratches, flaws and other defects that will affect life, serviceability, or appearance.

## 4. VERIFICATION

4.1 Test equipment and inspection facilities. Test and measuring equipment and inspection facilities of sufficient accuracy, quality, and quantity to permit performance of the required inspection shall be established and maintained by the supplier. The establishment and maintenance of a calibration system to control the accuracy of the measuring and test equipment shall be in accordance with ANSI-Z540.1-94.

4.2 Classification of inspections. The inspections specified herein shall be classified as follows:

- (a) First article inspection (see 4.4).
- (b) Conformance inspection (see 4.5).
  - (1) Inspection of product for delivery (see 4.5.1).

4.3 Inspection conditions. Unless otherwise specified herein, all inspections shall be performed in accordance with the test conditions specified in the "GENERAL REQUIREMENTS" of MIL-STD-202.

4.4 First article inspection. First article inspection shall be performed by the supplier, after award of contract and prior to production, at a location acceptable to the Government. First article inspection shall be performed on sample units that have been produced with equipment and procedures normally used in production. First article approval is valid only on the contract or purchase order under which it is granted, unless extended by the Government to other contracts or purchase orders.

4.4.1 Sample size. Three adapters shall be subjected to first article inspection.

4.4.2 Inspection routine. The samples shall be subjected to the inspections specified in table I, in the order shown. No failures shall be permitted.

Table I. First article inspection.

Examination or test	Requirement paragraph	Method paragraph	Number of sample to inspect
Visual and mechanical exam	3.1, 3.1.2 to 3.2.10, 3.12, 3.13	4.6.1	3
VSWR	3.4	4.6.2, 4.6.2.1	3
RF insertion loss <sup>1/</sup>	3.5	4.6.3	3
Pressurization	3.6	4.6.4	3
Shock (specified pulse)	3.7	4.6.5	3
Vibration	3.8	4.6.6	3
Salt spray (corrosion)	3.9	4.6.7	3
Dielectric withstanding voltage	3.10	4.6.8	3
Gauge (as specified)	3.11	4.6.9	3

<sup>1/</sup> When specified.

4.5 Conformance inspection.

4.5.1 Inspection of product for delivery. Inspection of product for delivery shall consist of groups A and B inspection.

4.5.1.1 Inspection lot. An inspection lot shall consist of all adapters of the same part or identifying number, produced under essentially the same conditions, and offered for inspection at one time.

4.5.1.2 Group A inspection. Group A inspection shall consist of visual and mechanical examination (see 4.6.1).

## MIL-DTL-22641D

4.5.1.2.1 Sampling plan. This specification utilizes an accept on zero defect ( $c = 0$ ) sampling plan. Statistical sampling and inspection shall be performed on an inspection lot basis with a random sample of adapters selected in accordance with Table II. No failures shall be permitted.

Table II. Group A Sampling Plan.

Lot size	Sample size
1 - 13	100 percent
14-150	13
151-280	20
281-500	29
501-1200	34
1201-3200	42
3201-10,000	50
10,001-35,000	60
35,001-150,000	74
150,001-500,000	90
500,001 and over	102

4.5.1.2.2 Rejected lots. If an inspection lot is rejected, the supplier may rework it to correct the defects, or to screen out the defective units, and to resubmit for reinspection. Resubmitted lots shall be separate from new lots and shall be clearly identified as reinspected lots. Reinspected lots shall be inspected using tightened inspection.

4.5.1.3 Group B inspection. Group B inspection shall consist of the tests specified in table III.

4.5.1.3.1 Sampling plan. This specification utilizes an accept on zero defect ( $c=0$ ) sampling plan. Statistical sampling and inspection shall be performed on an inspection lot basis with a random sample of adapters selected in accordance with Table II. No failures shall be permitted.

Table III. Group B inspection.

Test	Requirement paragraph	Method paragraph
VSWR	3.4	4.6.2, 4.6.2.1
RF insertion loss (when specified)	3.5	4.6.3
Pressurization	3.6	4.6.4
Gauge (as applicable)	3.11	4.6.9

4.5.1.3.2 Rejected lots. If an inspection lot is rejected, the supplier may rework it to correct the defects, or to screen out the defective units, and to resubmit for reinspection. Resubmitted lots shall be inspected using tightened inspection. Resubmitted lots shall be separate from new lots, and shall be clearly identified as reinspected lots.

4.5.1.3.3 Disposition of sample units. Sample units which have passed all the group B inspection may be delivered on the contract or purchase order, if the lot is accepted and the sample units are still within specified electrical tolerances. .

#### 4.6 Methods of examination and test.

4.6.1 Visual and mechanical examination. Adapters shall be examined to verify that the materials, design, construction, physical dimensions, workmanship and marking are in accordance with the applicable requirements (see 3.1, 3.1.2 to 3.2.10 inclusive, 3.12, and 3.13).

4.6.2 Voltage standing wave ratio (VSWR) (see 3.4). VSWR shall be measured over the specified frequency band (see 3.1), using the waveguide as the input end. The VSWR shall again be measured over the specified frequency band (see 3.1), using the series N or coaxial connection (as applicable) as the input end.

4.6.2.1 Procedure. VSWR of the assemblies shall be measured using a system as shown on figure 1, or equivalent, and shall be no greater than the value specified. Tuners and pads shall be used, where necessary, to reduce residual VSWR of the system to a level which will assure accurate results before connecting the assembly under test.

4.6.3 RF insertion loss (when specified) (see 3.5). The adapter shall be tested as shown in figure 2. Included in the insertion loss of the adapter is the reflection and dissipating loss of two standard test adapters - one for each interface of the adapter under test. Before performing the measurement on the adapter under test, the following two-step checkout procedure shall be performed:

Step 1 - The insertion loss of [1] and [2] of figure 2 shall be measured.

Step 2 - The insertion loss of [4] and [3] shall be measured.

To perform the measurement on the adapter under test, [1], [5], and [3] shall be inserted as shown, and the insertion loss shall be measured.

MIL-DTL-22641D

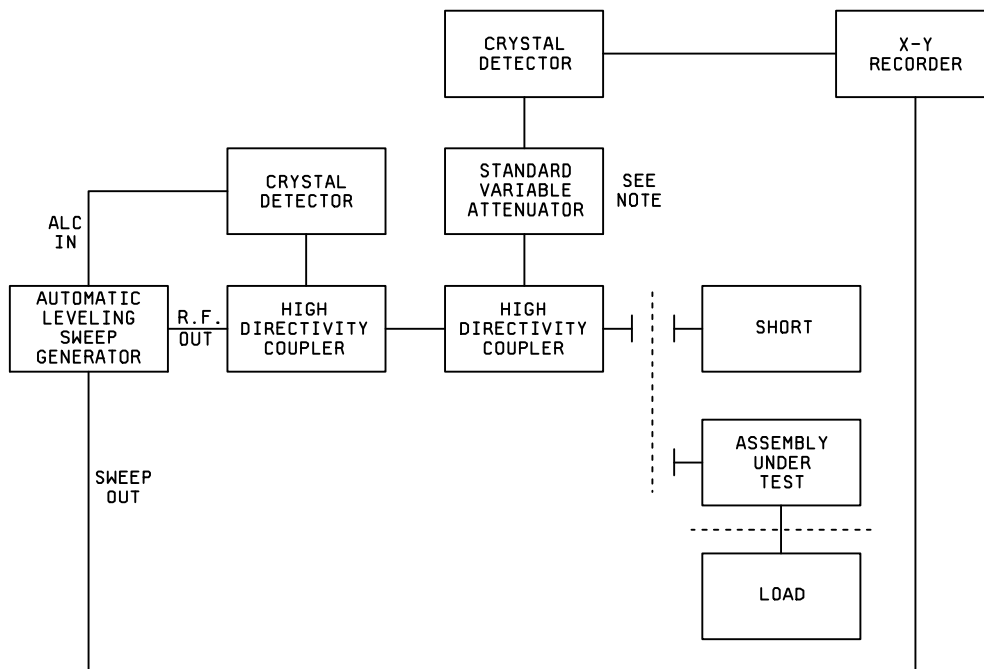

Note: Use 20 dB pad when calibrating for coaxial end measurements then remove.

FIGURE 1. VSWR test setup.

MIL-DTL-22641D

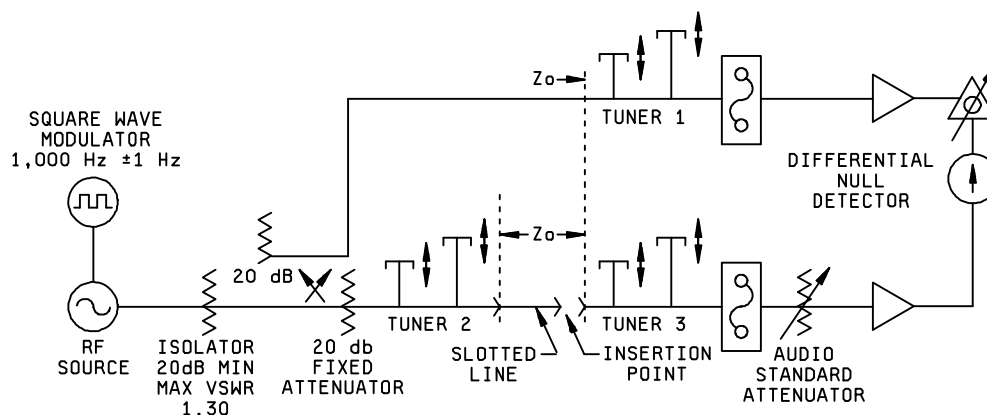

NOTE: Slotted line with low residual reflection, hermaphroditic output fitting compatible with tuner 3 input fitting. VSWR less than  $1.006 + .003F$  (F in GHz).

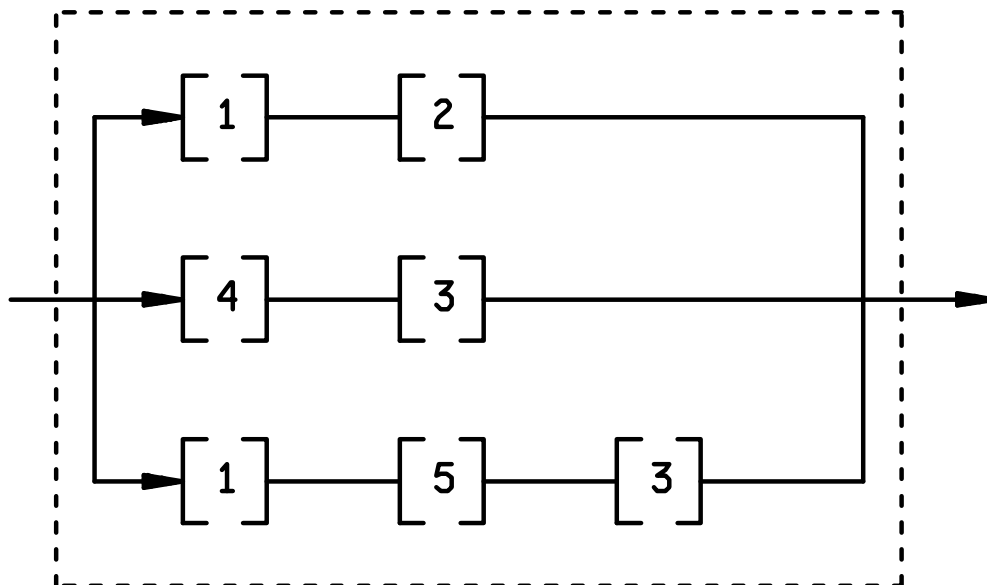

## NOTES:

1. Standard test adapter with hermaphroditic input fitting compatible with output fitting of slotted line, and output interface compatible with input interface of adapter to be tested.
2. Standard test adapter of opposite sex to [1] and hermaphroditic output fitting compatible with input fitting of tuner 3.
3. Standard test adapter with hermaphroditic output fitting compatible with input fitting of tuner 3, and input interface compatible with output interface of adapter to be tested.
4. Standard test adapter of opposite sex to [3] and hermaphroditic input fitting compatible with output fitting of the slotted line.
5. Adapter under test.

FIGURE 2. Method of insertion loss measurement.

## MIL-DTL-22641D

4.6.4 Pressurization (see 3.6). With the waveguide end properly sealed, adapters shall be subjected to the internal gas pressure specified (see 3.1) for a period of at least 20 seconds while immersed in tap water at a temperature of approximately 20°C. Where no limits are specified (see 3.1), the internal gas pressure shall be 30 pounds per square inch. During immersion, the adapters shall be observed for evidence of leakage as indicated by escaping air bubbles.

4.6.5 Shock (specified pulse) (see 3.7). Adapters shall be tested in accordance with method 213, test condition G of MIL-STD-202, with requirement of one shock applied to each of the three mutually perpendicular axes of the test specimen. After this test, VSWR and insertion loss shall be measured as specified in 4.6.2, 4.6.2.1 and 4.6.3.

4.6.6 Vibration (see 3.8). Adapters shall be tested in accordance with method 201 of MIL-STD-202. The following details and exceptions shall apply:

- (a) Initial measurements - Not applicable.
- (b) Method of mounting - Adapters shall be attached to the vibration table by a clamp. No part of the adapter shall touch any object other than the clamp.
- (c) Direction of motion - One hour in each of three mutually perpendicular directions (total of 3 hours).
- (d) Final measurements - After this test, VSWR and insertion loss shall be measured as specified in 4.6.2, 4.6.2.1, and 4.6.3 and the pressurization test shall be performed as specified in 4.6.4.

4.6.7 Salt spray (corrosion) (see 3.9). Unless otherwise specified (see 3.1), adapters shall be tested in accordance with method 101 of MIL-STD-202. The following details and exceptions shall apply:

- (a) Applicable salt solution - 5 percent.
- (b) Test condition - A.
- (c) Examination after test - Adapters shall be washed, dried, and examined for destructive corrosion or pitting.

4.6.8 Dielectric withstanding voltage (see 3.10). Adapters shall be tested in accordance with method 301 of MIL-STD-202. The following details shall apply:

- (a) Special preparations or conditions:
  - (1) The temperature shall be approximately 23°C (73.4°F); the pressure shall be approximately 30 inches of mercury absolute; the maximum relative humidity shall be 50 percent. When facilities are not available for these specified test conditions, the adapters shall be tested at the prevailing atmospheric conditions. In case of dispute, retest shall be made at the specified test conditions.
  - (2) Precautions shall be taken to prevent air-gap voltage breakdown.
- (b) Magnitude of test voltage - 1500 volts root mean square instantaneously applied, except for Class 5 adapters in which case 1000 volts root mean square shall be applied.
- (c) Nature of potential - Alternating current.
- (d) Points of application of test voltage - Between the center conductor and the outer shell of the adapter.
- (e) Examination - After the test, adapters shall be examined for evidence of breakdown.

4.6.9 Gauge test (as applicable) (see 3.11).

4.6.9.1 Class 1, 4, and 5 adapters. Class 1, 4, or 5 adapters shall be rigidly mounted in a suitable jig or fixture and the applicable mating characteristics specified in table IV shall be measured. For measurements of required forces, a gauge containing the test pin and a suitable force indicating dial shall be aligned to within 0.004 TIR of any plane passing through the axis of the center contact. Insertion or withdrawal of the test pin shall be made smoothly and at a rate such that the dial does not bounce or otherwise give a false reading. The test pin may be chamfered to facilitate entry, but the specified insertion length shall not include the chamfer length and the finish shall be 16 microinches.

Table IV. Mating characteristics.

Test	Class 1	Class 4	Class 5
Oversize test pin	0.074 + .0001 inch diameter (nonclosed entry contact only)	.057 + .0001 inch diameter (nonclosed entry contact only)	.0375 + .0001 inch diameter
Insertion depth	.125 inch minimum	.125 inch minimum	.030/.045 inch
Number of insertions	1	1	3
Max diameter test pin	Steel test pin diameter .066 + .0001 inch	Steel test pin diameter .054 + .0001 inch	Steel test pin diameter .0370 + .0001 inch : (Insertion depth - .050/.075)
Insertion force	2 bs maximum	2 bs maximum	3 lbs maximum
Min diameter test pin	Steel test pin diameter .063 - .0001 inch	Steel test pin diameter .052 - .0001 inch	.0355 - .0001 inch diameter (Insertion depth - .050/.075)
Withdrawal force	2 ounces minimum	2 ounces minimum	1 ounce minimum



## MIL-DTL-22641D

4.6.9.2 Class 2 adapters. For class 2 adapters, the gauge test shall be as follows:

- (a) The 0.625-inch coaxial female fittings shall be equivalent to standard female coupling UG-141/U, and shall be capable of properly mating with 0.625-inch coaxial male fitting that is equivalent to a standard male coupling UG-140/U.
- (b) The 0.625-inch coaxial male fittings shall be equivalent to standard male coupling UG-140/U, and shall be capable of properly mating with a standard female coupling UG-141/U.
- (c) Mating shall be considered accomplished after 25 successful insertions and withdrawals.

4.6.9.3 Class 3 adapters. For class 3 adapters, the gauge test shall be as follows:

- (a) The 0.875-inch coaxial female fittings shall be equivalent to standard female coupling UG-46/U, and shall be capable of properly mating with a 0.875-inch coaxial male fitting which is equivalent to a standard male coupling UG-45/U.
- (b) The 0.875-inch coaxial male fittings shall be equivalent to standard male coupling UG-45/U, and shall be capable of properly mating with a standard female coupling UG-46/U.
- (c) Mating shall be considered accomplished after 25 successful insertions and withdrawals.

## 5. PACKAGING

5.1 Packaging. For acquisition purposes, the packaging requirements shall be as specified in the contract or order (see 6.2). When actual packaging of material is to be performed by DoD personnel, these personnel need to contact the responsible packaging activity to ascertain requisite packaging requirements. Packaging requirements are maintained by the Inventory Control Point's packaging activity within the Military Department or Defense Agency, or within the Military Department's System Command. Packaging data retrieval is available from the managing Military Department's or Defense Agency's automated packaging files, CD-ROM products, or by contacting the responsible packaging activity.

## 6. NOTES

(This section contains information of a general or explanatory nature which may be helpful, but is not mandatory.)

6.1 Intended use. Adapters covered by this specification are intended for use in the microwave region of the electromagnetic frequency spectrum.

6.2 Acquisition requirements. Acquisition documents must specify the following:

- (a) Title, number, and date of this specification.
- (b) Title, number, and date of the applicable specification sheet, and the complete part number (see 3.1 and 6.2.1).
- (c) Issue of DoDISS to be cited in the solicitation, and if required, the specific issue of individual documents referenced (see 2.2.1 and 2.3).

6.2.1 Part or Identifying Number (PIN). The PIN consists of the letter "M", the basic number of the specification sheet, and an assigned dash number as shown in the following example (see 3.1):

M 22641/16 - 001

M	-	Military designator
22641/16	-	Specification sheet number
001	-	Dash number

6.3 Subject term (key word) listing.

- Connectors
- Dissimilar metals
- Flange
- Insertion loss
- Mating
- Microwave
- Radio frequency (RF)
- Series N
- Series SMA
- Series TNC
- Soldering
- VSWR

MIL-DTL-22641D

6.4 Definitions. For the purpose of this specification, the following definition applies:

6.4.1 Dissimilar metals. Dissimilar metals are defined in MIL-STD-889.

6.5 Changes from previous issue. Marginal notations are not used in this revision to identify changes with respect to the previous issue due to the extent of the changes.

6.6 Engineering information. Illustrations and additional engineering information for currently available adapters are included in MIL-HDBK-216, RF Transmission Lines and Fittings.

Custodians:

Army - CR  
Navy - EC  
Air Force - 11  
DLA - CC

Preparing activity:  
DLA - CC

(Project 5985-1124)

Review activities:

Army - AR, GL, MI  
Navy - AS, MC, OS  
Air Force - 99

MIL-DTL-22641D

**STANDARDIZATION DOCUMENT IMPROVEMENT PROPOSAL****INSTRUCTIONS**

1. The preparing activity must complete blocks 1, 2, 3, and 8. In block 1, both the document number and revision letter should be given.
2. The submitter of this form must complete blocks 4, 5, 6, and 7.
3. The preparing activity must provide a reply within 30 days from receipt of the form.

NOTE: This form may not be used to request copies of documents, nor to request waivers, or clarification of requirements on current contracts. Comments submitted on this form do not constitute or imply authorization to waive any portion of the referenced document(s) or to amend contractual requirements.

<b>I RECOMMEND A CHANGE:</b>	<b>1. DOCUMENT NUMBER</b> MIL-DTL-22641D	<b>2. DOCUMENT DATE</b> 31 January 2000
<b>3. DOCUMENT TITLE</b> ADAPTERS, COAXIAL TO WAVEGUIDE, GENERAL SPECIFICATION FOR		
<b>4. NATURE OF CHANGE</b> <i>(Identify paragraph number and include proposed rewrite, if possible. Attach extra sheets as needed.)</i>		
<b>5. REASON FOR RECOMMENDATION</b>		
<b>6. SUBMITTER</b>		
a. NAME (Last, First, Middle initial)	b. ORGANIZATION	
c. ADDRESS (Include Zip Code)	d. TELEPHONE (Include Area Code) Commercial DSN FAX EMAIL	7. DATE SUBMITTED
<b>8. PREPARING ACTIVITY</b>		
a. Point of Contact ATTN: DSCC-VAT	b. TELEPHONE Commercial      DSN      FAX      EMAIL 614-692-0506    850-0506    614-692-6941    david_arps@dsccl.dla.mil	
c. ADDRESS Defense Supply Center Columbus P.O. Box 3990 Columbus, OH 43216-5000	<b>IF YOU DO NOT RECEIVE A REPLY WITHIN 45 DAYS, CONTACT:</b> Defense Standardization Program Office (DLSC -LM) 8725 John J. Kingman Road, Suite 2533 Fort Belvoir, Virginia 22060-6221 Telephone (703) 767-6888    DSN 427-6888	