

INCH-POUND

MIL-DTL-21617B
 6 April 2012
 SUPERSEDING
 MIL-DTL-21617A
 24 July 2003

DETAIL SPECIFICATION

CONNECTORS, PLUG AND RECEPTACLE, ELECTRICAL, RECTANGULAR, POLARIZED SHELL, MINIATURE TYPE GENERAL SPECIFICATION FOR

This specification is approved for use by all Departments
 and Agencies of the Department of Defense.

1. SCOPE

1.1 Scope. This specification covers multi-contact, rectangular, polarized shell, miniature type, electrical and electronic rack and panel connectors (plugs and receptacles).

1.2 Classification. Connectors are of the following types, classes, and styles, as specified herein.

1.2.1 Part or Identifying Number (PIN). The PIN consist of the letter "M", the basic number of the specification sheet, and an assigned dash number as shown in the following example:

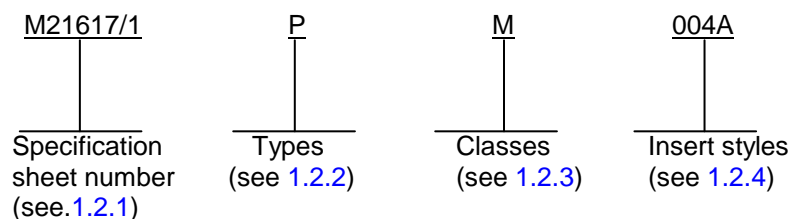

1.2.2 Types.

- Type P - Plug.
- Type J - Receptacle.
- Type JS - Receptacle, pressurized type.

Comments, suggestions, or questions on this document should be addressed to: DLA Land and Maritime, ATTN: VAI, P.O. Box 3990, Columbus, OH 43218-3990 or email: RectangularConnector@dla.mil. Since contact information can change, you may want to verify the currency of this address information using the ASSIST Online database at <https://assist.daps.dla.mil/>.

MIL-DTL-21617B

1.2.3 Classes.

Class F - Female, inserts containing socket contacts.

Class M - Male, inserts containing pin contacts.

1.2.4 Insert styles.

- 004A - 4 contacts
- 008A - 8 contacts
- 013A - 13 contacts
- 017A - 17 contacts
- 023A - 23 contacts
- 026A - 26 contacts
- 032A - 32 contacts
- 040A - 40 contacts
- 007C - 7 coaxial contacts
- 016C - 3 coaxial contacts and 13 size 20 contacts

2. APPLICABLE DOCUMENTS

2.1 General. The documents listed in this section are specified in sections 3, 4, or 5 of this specification. This section does not include documents cited in other sections of this specification or recommended for additional information or as examples. While every effort has been made to ensure the completeness of this list, document users are cautioned that they must meet all specified requirements documents cited in sections 3, 4, or 5 of this specification, whether or not they are listed.

2.2 Government documents.

2.2.1 Specifications, standards, and handbooks. The following specifications, standards, and handbooks form a part of this document to the extent specified herein. Unless otherwise specified, the issues of these documents are those cited in the solicitation or contract.

DEPARTMENT OF DEFENSE STANDARDS

- MIL-STD-202 - Test Methods for Electronic and Electrical Component Parts.
- MIL-STD-889 - Dissimilar Metals.

(Copies of these documents are available online at <https://assist.daps.dla.mil/quicksearch/> or from the Standardization Document Order Desk, 700 Robbins Avenue, Building 4D, Philadelphia, PA 19111-5094.)

MIL-DTL-21617B

2.3 Non-Government publications. The following documents form a part of this document to the extent specified herein. Unless otherwise specified, the issues of these documents are those cited in the solicitation or contract (see 6.2).

ASTM INTERNATIONAL

- ASTM B85/B85M - Aluminum-Alloy Die Castings
- ASTM B488 - Gold for Engineering Uses Electrodeposited Coatings Of
- ASTM D2000 - Rubber Products in Automotive Applications
- ASTM D5948 - Compounds, Molding, Thermosetting

(Copies of these documents are available online at <http://www.astm.org> or to the American Society for Testing and Materials, 1916 Race Street, Philadelphia, PA 19103-1187.)

ELECTRONIC COMPONENTS INDUSTRY ASSOCIATION (ECIA)

- EIA-364 - Electrical Connector/Socket Test Procedures Including Environmental Classifications
- EIA-364-06 - Contact Resistance Test Procedure for Electrical Connectors
- EIA-364-20 - Withstanding Voltage Test Procedure for Electrical Connectors, Sockets and Coaxial Contacts
- EIA/ECA-364-21 - Insulation Resistance Test Procedure for Electrical Connectors, Sockets, and Coaxial Contacts
- EIA-364-25 - Probe Damage Test Procedure for Electrical Connectors
- EIA/ECA-364-26 - Salt Spray Test Procedure for Electrical Connectors, Contacts and Sockets
- EIA-364-27 - Mechanical Shock (Specified Pulse) Test Procedure for Electrical Connectors
- EIA-364-28 - Vibration Test Procedure for Electrical Connectors and Sockets
- EIA-364-32 - Thermal Shock (Temperature Cycling) Test Procedure for Electrical Connectors and Sockets
- EIA-364-56 - Resistance to Soldering Heat Test Procedure for Electrical Connectors and Sockets

(Copies of these documents are available online at <http://www.eciaonline.org> or from the Electronic Component Industry Association, 1111 Alderman Drive, Suite 400, Alpharetta, GA 30005-4175.)

IPC – ASSOCIATION CONNECTION ELECTRONICS INDUSTRIES

- J-STD-004 - Soldering Fluxes Requirements For
- J-STD-006 - Electronic Grade Solder Alloys and Fluxed and Non-Fluxed Solid Solders for Electronic Soldering Applications Requirements For

(Copies of these documents are available online at <http://www.ipc.org> or from the IPC - Association Connecting Electronics Industries, 3000 Lakeside Drive, Suite 309 S, Bannockburn, IL 60015-1249.)

MIL-DTL-21617B

SAE INTERNATIONAL

SAE-AMS-P-81728	- Plating, Tin-Lead (Electrodeposited)
SAE-AMS-QQ-N-290	- Nickel Plating (Electrodeposited)
SAE-AMS-QQ-P-416	- Plating, Cadmium (Electrodeposited)
SAE-AMS2700	- Passivation of Corrosion Resistant Steels

(Copies of these documents are available from SAE International, 400 Commonwealth Drive, Warrendale, PA 15096-0001, Tel: 877-606-7323 (inside USA and Canada) or 724-776-4970 (outside USA), www.sae.org.)

2.4 Order of precedence. Unless otherwise noted herein or in the contract, in the event of a conflict between the text of this document and the references cited herein (except for related specification sheets), the text of this document takes precedence. Nothing in this document, however, supersedes applicable laws and regulations unless a specific exemption has been obtained.

3. REQUIREMENTS

3.1 Specification sheets. The individual item requirements shall be as specified herein and in accordance with the applicable specification sheet. In the event of any conflict between the requirements of this specification and the specification sheet, the latter shall govern.

3.2 First article. When specified (see 6.2), a sample shall be subjected to first article inspection in accordance with 4.3.

3.3 Materials. Materials shall be as identified herein. However, when a definite material is not specified, a material shall be used which will enable the connectors to meet all requirements of this specification. Acceptance or approval of any constituent material shall not be construed as a guarantee for acceptance of the finished product.

3.3.1 Interface materials, platings and processes. Interface materials, platings, and processes have been established to provide assurances that connectors manufactured to this specification will properly interface to similar industry standard or government specified connector systems without problems of electrochemical incompatibility or excessive interface surface wear. The manufacturers of connectors supplied to this specification may be allowed to use alternate recognized industry standard materials, platings, and processes from those identified in 3.3. Alternate materials, platings and processes used must be coordinated with the qualifying activity as part of the qualification process. Use of alternates to those referenced guidance items by the supplier must not result in inferior short or long term performance or reliability of supplied connectors as compared with connectors manufactured using the referenced materials, platings, or processes. Short or long term failures or reliability problems due to use of these alternates shall be the responsibility of the supplier.

3.3.2 Recycled, recovered, or environmentally preferable materials. Recycled, recovered or environmentally preferable materials should be used to the maximum extent possible provided that the material meets or exceeds the operational and maintenance requirements, and promotes economically advantageous life cycle costs.

3.3.3. Metals and finishes. All exposed metal parts, other than electrical contacts, may be aluminum, aluminum alloy, brass, steel or corrosion resistant steel. All exposed metal parts, other than electrical contacts, shall be cadmium plated in accordance with SAE-AMS-QQ-P-416, type II, class 3, except that preliminary plating of other metal will be permissible. The resultant finish shall be electrically conductive.

MIL-DTL-21617B

3.3.4 Dissimilar metals. When dissimilar metals are used in intimate contact with each other, protection against electrolysis and corrosion shall be provided. The use of dissimilar metals, which in contact, tend toward active electrolytic corrosion (particularly brass, copper, or steel used in contact with aluminum and aluminum alloy is not acceptable (see 3.3.3). For guidance, reference MIL-STD-889. Where dissimilar metals are used in intimate contact with each other, protection against electrolysis and corrosion shall be provided. Dissimilar metals such as brass, copper or steel (except corrosion-resisting steel), shall be passivated in accordance with SAE-AMS2700 (see 3.3.1) and shall not be used in intimate contact with aluminum or aluminum alloy.

3.3.5. Pure tin. The use of pure tin is prohibited. Tin content used in connector materials shall not exceed 97 percent, and an alloy material shall be chosen to inhibit the growth of tin whiskers (see 6.3).

3.3.6 Nonmagnetic materials. All parts shall be made from materials considered to be nonmagnetic.

3.3.7 Shell die castings. Shell die castings and workmanship shall be aluminum in accordance with ASTM B85/B85M alloys A13800, A03840, or A14130.

3.3.8 Insert materials.

3.3.8.1 Rigid insert material. Rigid insert materials shall be mineral filled type conforming to Melamine type MME, Diallyl Orho-Phthalatic type MDG or Diallyl Iso-Phalatec type MIG in accordance with ASTM D5948.

3.3.8.2 Resilient materials. Resilient materials shall be in accordance with ASTM D2000, M2BC 710 A24B24E034 and shall be molded of a high grade resilient dielectric or elastomer having a shore hardness not greater than 85 and shall conform to the additional requirements specified herein.

3.4 Electrical characteristics. Connectors shall have the electrical characteristics shown on table I.

TABLE I. Nominal current rating.

Contact size	Amperes
20	7.5
16	13.0
12	23.0
8	46.0
4	80.0

3.5 Design and construction. Connectors shall be of the design, construction, and physical dimensions specified herein and in accordance with the applicable specification sheets (see 3.1). Bosses and barriers shall be used as necessary to meet leakage requirements.

3.5.1 Insert design. Inserts shall be designed and constructed with proper sections and radii in order that they will not crack, chip, or break in assembly or in normal service. Structural weakness shall not be caused by depressions used to achieve longer creepage paths.

MIL-DTL-21617B

3.5.2 Contacts. Contact dimensions shall conform to table II and shall be as shown on figure 1.

TABLE II. Contact dimensions. 1/

Contact size	A \pm .001 (0.025) (mm)	B minimum (mm)	C maximum (mm)	D minimum (mm)	E minimum (mm)
20	.040 (1.02)	.043 (1.09)	.090 (2.29)	.070 (1.78)	.093 (2.36)
16	.0625 (1.59)	.065 (1.65)	.127 (3.23)	.078 (1.98)	.125 (3.17)
12	.094 (2.39)	.112 (2.84)	.190 (4.83)	.156 (3.96)	.375 (9.52)
8	.142 (3.61)	.207 (5.26)	.300 (7.62)	.250 (6.35)	.312 (7.92)
4	.225 (5.71)	.262 (6.65)	.441 (11.20)	.312 (7.92)	.312 (7.92)

1/ All dimensions are after plating.

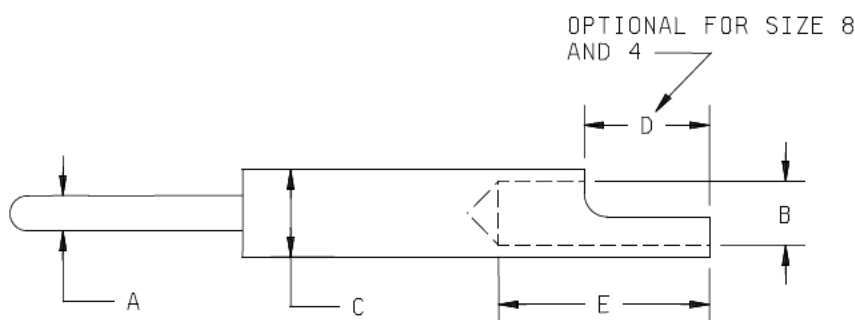

FIGURE 1. Contact dimensions.

3.5.3 Contact material. Contacts shall be made from copper alloy material and shall be gold plated in accordance with ASTM B488, type II, code C, class 1.27 (50 microinches) minimum, over a nickel underplate 50 to 150 microinches (1.27 μ m to 3.81 μ m) thick, in accordance with SAE-AMS-QQ-N-290. Silver shall not be used as an underplate.

3.5.4 Terminals. The interior surfaces of the solder cups of the contacts shall be either gold flash or tin/lead, the following details shall apply:

- Gold flash, over a nickel underplate 50 to 150 microinches (1.27 μ m to 3.81 μ m) thick, in accordance with SAE-AMS-QQ-N-290.
- Tin/lead in accordance with SAE-AMS-P-81728.

3.5.5 Tinning solder cups. Where pretinned solder cups are required, the interior surface of solder cups shall be completely tinned over 100 percent of the full circle portion and for at least 50 percent of the remainder of the solder well area with solder conforming to composition Sn60 of J-STD-006. Only fluxes meeting J-STD-004, shall be used, any excess of which shall be removed. Solder cup terminals shall be so constructed that liquid solder cannot leak through to the front of the socket and prevent insertion of the pin. No excess solder shall be on the exterior of the solder cup.

MIL-DTL-21617B

3.5.6 Contact identification. Contact positions shall be designated as specified in the individual specification sheets. Letters or numerals shall be clearly legible and shall be either raised or depressed. Letters or numerals shall be arranged to avoid confusion between contacts. All letters shall appear on the front of each insert and, as many as practical, on the rear face. Lettering of the socket insert shall correspond with that of the mating pin insert.

3.5.7 Contact arrangement. Contacts shall be arranged in accordance with the individual specification sheet requirements.

3.5.8 Contact design. Contacts shall be so designed that mating or unmating the connectors will not damage them.

3.5.8.1 Pin engaging end. The entering ends of pins, sizes 8, 12, and 16, shall be formed with a spherical radius approximately one-half the diameter of the pin, allowing for a flat not in excess of 0.015 inch (0.38 mm) diameter in the center of the spherical development. The entering end of size 20 pin shall be either formed with a spherical or a conical tip. The tip of the spherical end of the size 4 pin shall be cut off to form a blunt end such that the diameter of the blunt end shall be .125 inch (3.18 mm) less than the pin diameter.

3.5.8.2 Socket engaging end. The entering end of the socket contact shall be rounded or chamfered to allow for directing and centering of the entering pin. The socket contact shall provide the spring action for maintaining the contact pressure between the pin and socket. Size 16 socket contact shall be of the closed entry design to exclude the entrance of a pin .005 inch (0.13 mm) larger than the allowable maximum diameter of a mating pin. Socket contact size 20 shall be either closed or open entry design. Closed entry socket contacts size 16 shall pass the resistance to test prod damage test specified in [4.5.12](#).

3.5.9 Polarization. Polarization of the plug, with its receptacle, shall be accomplished by the shells. The polarization of the plug with its receptacle shall be accomplished before engagement of contact pins in their respective sockets.

3.5.10 Mating. Plugs and receptacles shall be capable of being mated and unmated by hand without the aid of any tools within the operating temperature range for these connectors (see [3.5.13](#)).

3.5.11 Connector shell design. Connector shell design shall be either solid or split shell design.

3.5.12 Connector shells. Connector shells, both plug and receptacle shall be provided with a means of accommodating back shells for straight and 90° angle exit of the cable from the connector assembly. Back shells, both straight and right angle, are accessories and are not supplied as a part of the connector assembly.

3.5.13 Operating temperature. Connectors shall have maximum operating temperature of +125°C and a minimum operating temperature of -55°C.

3.6 Performance.

3.6.1 Insulation resistance. When tested as specified in [4.5.2](#), the initial insulation resistance shall be not less than 5,000 megohms. After being subjected to the moisture resistance test specified in [4.5.13](#), the insulation resistance shall be not less than 1 megohm.

3.6.2 Withstanding voltage. When tested as specified in [4.5.3](#), connectors shall be capable of withstanding the applicable test voltages shown in table III without flashover.

MIL-DTL-21617B

TABLE III. Withstanding test voltages.

Service rating	Sea level test voltage 60 Hz (rms)
A	1,500
D	2,000
E	2,800
Coaxial contacts	1,000

3.6.3 Vibration. When the complete connector assembly, wired with the appropriate size wire, is tested as specified in 4.5.4, there shall be no cracking, breaking, or loosening of parts. There shall be no loss of electrical continuity of any of the contact circuits.

3.6.4 Mechanical shock (specified pulse). When tested as specified in 4.5.5, there shall be no evidence of mechanical failure of metallic or dielectric materials.

3.6.5 Insertion and withdrawal force (mated connectors). When tested as specified in 4.5.6, the force required to either engage or separate any pair of mated connectors (plug and receptacle) shall not exceed a maximum force of 30 pound-force (13.6 kilogram force).

3.6.6 Durability. The connector assembly shall withstand the test specified in 4.5.7 without evidence or mechanical damage.

3.6.7 Contact resistance. When tested as specified in 4.5.8, the resistance of mated pin and socket contacts at +25°C ±3°C, shall not exceed the voltage drop at the current rating specified in table IV.

TABLE IV. Contact resistance.

Contact size	Test current (amperes)	Voltage drop (millivolts) maximum
20	7.5	35
16	20	40
12	35	35
8	60	30
4	110	25

3.6.8 Contract retention. Individual contacts shall withstand the axial loads shown in 4.5.9.

3.6.9 Contact separation. When tested as specified in 4.5.10, the force to separate an individual gauge pin of minimum size shall meet the minimum individual force and not exceed the maximum individual force values shown in table V.

MIL-DTL-21617B

TABLE V. Contact separation forces.

Contact size	Test pin +.0002, -.0000 (+0.005 - 0.000 mm) (mm)	Maximum average force pounds (Newton)	Minimum individual force pounds (gram force)
20	.039 (1.00)	.625 (2.78)	.0625 (28.35)
16	.0615 (1.52)	1.500 (6.67)	.1875 (85.05)
12	.093 (2.36)	2.750 (7.78)	.375 (170.1)
8	.141 (3.58)	5.000 (22.24)	.625 (283.5)
4	.224 (5.69)	8.000 (35.60)	.750 (340.2)

3.6.10 Insert retention. Connector inserts shall not show evidence of physical damage when tested as specified in 4.5.11.

3.6.11 Resistance to test prod damage (size 16 socket contacts). When tested as specified in 4.5.12, the socket contacts shall be capable of withstanding the contact separation test of 4.5.10.

3.6.12 Moisture resistance. When tested as specified in 4.5.13, connectors shall meet a potential test of one and one-half times the ac voltage specified in table VI for a period of 5 minutes between any pair of contacts or any contact to shell.

TABLE VI. Service rating voltages. ^{1/}

Service rating	AC volts (rms) 60 Hz
A	350
D	500
E	900

^{1/} Basic voltages, for moisture resistance and salt spray (corrosion) tests.

3.6.13 Air leakage, type JS receptacle (not applicable to styles 007C and 016C). When pressurized connectors are tested as specified in 4.5.14, there shall be no leakage in excess of 1 cubic inch (16.4 milliliter) per hour of air at a pressure differential of 30 psi (2.07 kilopascal).

3.6.14 Thermal shock. When tested as specified in 4.5.15, connectors shall not show evidence of physical damage after being subjected to temperature cycling test from +125°C to -55°C.

3.6.15 Salt spray (corrosion). When tested as specified in 4.5.16, exposure to a salt laden atmosphere shall not cause sufficient corrosion to interfere with mating or unmating the connectors. There shall be no exposure of the base metal on the 25 sets of individual pin and socket contacts subjected to the test. The connectors shall meet a potential test of twice the ac voltage specified in table VI.

3.6.16 Solderability. Solderable, contact terminations shall withstand the test specified in 4.5.17, unless solder cup terminations are specified. For solder cup terminations contacts may be removed from the insulator or an alternate method using a hand iron may be used on the contacts in an assembled (non-removed) configuration.

MIL-DTL-21617B

3.6.17 Resistance to soldering heat. When tested as specified in 4.5.18, the connectors shall be visually inspected and shall show no evidence of distortion or physical damage and shall meet the contact retention requirements of 3.6.8.

3.7 Interchangeability. Receptacles of a given size and design manufactured by one source to the requirements of this specification shall be capable of mating with associated plugs manufactured to the requirements of this specification by other sources. The connector assemblies having the same part number shall be directly and completely interchangeable with each other with respect to installation and performance as specified herein.

3.7.1 Identification marking of connectors. Each connector shall be legibly and permanently marked, die cast, or stamped as indicated in the individual type requirements (see 3.8), with the manufacturer's name or trademark and with the appropriate PIN as specified in the individual slash sheets.

3.8 Workmanship. Connectors shall meet the design and dimensional requirements of this specification. There shall be no evidence of loose contacts, poor molding or fabricating, damaged or improperly assembled contacts, peeling or chipping of the plating and finish, parting lines of mold which would indicate flash and improper molding techniques, improper tinning of solder cups, nicks and burrs of metal parts surfaces, and no post molding warpage of connectors (see 4.5.1).

4. VERIFICATION

4.1 Classification of inspection. The inspection of connectors shall be classified as follows:

- a. First article inspection (see 4.3).
- b. Conformance inspection (see 4.4).

4.2 Inspection conditions. Unless otherwise specified, all inspections shall be performed in accordance with the test conditions specified in MIL-STD-202 and EIA-364.

4.3 First article inspection. First article inspection shall be performed by the contractor, after award of contract and prior to production, at a location acceptable to the Government. First article inspection shall be performed on sample units, which have been produced with equipment and procedures normally used in production. First article approval is valid only on the contract under which it is granted, unless extended by the Government to other contracts.

4.3.1 Sample size. Eight (8) connector pairs shall be subjected to first article inspection.

4.3.2 Inspection routine. The sample pairs shall be subjected to the inspections in table VII, in the order shown. All sample units shall be subjected to the inspections of group I. The sample shall be divided equally into four groups of two pairs each, and subjected to the inspections for their particular group.

4.3.3 Failures. One or more failures shall be cause for refusal to grant lot approval.

MIL-DTL-21617B

TABLE VII. First article inspection.

Inspection	Requirement paragraph	Test paragraph	Condition
<u>Group I</u>			
Visual and mechanical examination	3.1, 3.5 and 3.8	4.5.1	All connectors
Insulation resistance	3.6.1	4.5.2	Mated
Withstanding voltage	3.6.2	4.5.3	Unmated
Vibration	3.6.3	4.5.4	Mated
Mechanical shock	3.6.4	4.5.5	Mated
Insertion and withdrawal force (mated connectors)	3.6.5	4.5.6	Mate/unmate
Durability	3.6.6	4.5.7	Unmated
Contact resistance	3.6.7	4.5.8	Mated
<u>Group II</u>			
Visual and mechanical examination	3.1, 3.5 and 3.8	4.5.1	All connectors
Contact retention	3.6.8	4.5.9	Unmated
Contact separation	3.6.9	4.5.10	Unmated
Insert retention	3.6.10	4.5.11	Unmated
Resistance to test prod damage (initial test) <u>1/</u>	3.6.11	4.5.12.1	Unmated
Contact separation (socket contacts) <u>1/</u>	3.6.9	4.5.10	Unmated
Resistance to test prod damage <u>1/</u>	3.6.11	4.5.12.2	Unmated
Contact separation (socket contacts) <u>1/</u>	3.6.9	4.5.10	Unmated
Moisture resistance	3.6.12	4.5.13	Unmated
Insulation resistance	3.6.1	4.5.2	Mated
Air leakage (type JS receptacle only)	3.6.13	4.5.14	Mated
Thermal shock	3.6.14	4.5.15	Mated
<u>Group III</u>			
Visual and mechanical examination	3.1, 3.5 and 3.8	4.5.1	All connectors
Salt spray (corrosion)	3.6.15	4.5.16	Unmated
<u>Group IV</u>			
Visual and mechanical examination	3.1, 3.5 and 3.8	4.5.1	All connectors
Solderability	3.6.16	4.5.17	Unmated
Resistance to soldering heat	3.6.17	4.5.18	Unmated
Contact retention	3.6.8	4.5.9	Unmated

1/ Size 16 socket contacts.

4.4 Conformance inspection.

4.4.1 Inspection of product for delivery. Inspection of product for delivery shall consist of groups A and B inspections and shall be performed on a lot-by-lot basis.

4.4.2 Inspection lot. An inspection lot shall consist of all connectors of the same PIN, produced under essentially the same conditions, and offered for inspection at one time.

MIL-DTL-21617B

4.4.2.1 Group A inspection. Group A inspection shall consist of the inspections specified in table VIII in the order shown and shall be performed on a sample of parts randomly selected in accordance with table IX. If one or more defects are found, the lot shall be screened for that particular defect and the defects removed. After screening and removal of the defects, a new sample of parts shall be randomly selected in accordance with the tightened inspection sampling plan shown in table IX, and the lot shall be retested. If one or more defects are found in the second sample, the lot shall be rejected and shall not be supplied to this specification. Group A shall be performed on a lot-by-lot basis.

4.4.2.1.1 Sampling plan for group A. The sampling plan for group A shall be in accordance with table IX.

TABLE VIII. Group A inspection.

Inspection	Requirement paragraph	Test method paragraph	Sampling plan
Visual and mechanical inspection	3.1, 3.5 and 3.8	4.5.1	See table IX

TABLE IX. Sampling plan for group A inspection.

Lot size	Sample size	Sample size (tightened inspection)
2 to 15	All	All
16 to 25	20	20
26 to 280	20	32
281 to 500	47	48
501 to 1,200	47	73
1,201 to 3,200	53	73
3,201 to 10,000	68	86
10,001 to 35,000	77	100

4.4.2.2 Group B inspection. Group B inspection shall consist of the inspections specified in table X in the order shown, and shall be performed on a sample of parts randomly selected in accordance with table IX from an inspection lot which has previously passed the group A inspections. If one or more defects are found, the lot shall be screened for that particular defect and the defects removed. After screening and removal of the defects, a new sample of parts shall be randomly selected in accordance with the tightened inspection sampling plan shown in table XI, and the lot shall be retested. If one or more defects are found in the second sample, the lot shall be rejected and shall not be supplied to this specification. Group B shall be performed on a lot-by-lot basis.

MIL-DTL-21617B

TABLE X. Group B inspection.

Inspection	Requirement paragraph	Test paragraph	Sampling plan
Contact resistance	3.6.7	4.5.8	See table XI
Insulation resistance	3.6.1	4.5.2	
Dielectric withstanding voltage	3.6.2	4.5.3	

4.4.2.2.1 Sampling plan for group B. The sampling plan for group B shall be in accordance with table XI.

TABLE XI. Sampling plan for group B inspection.

Lot size	Sample size	Sample size (tightened inspection)
2 to 8	All	All
9 to 15	13	All
16 to 25	13	20
26 to 50	13	20
51 to 90	13	20
91 to 150	13	20
151 to 280	20	20
281 to 500	29	47
501 to 1,200	34	47
1,201 to 3,200	42	53
3,201 to 10,000	50	68
10,001 to 35,000	60	77

4.4.3 Disposition of sample units. Lot sample units, which have passed group A or B inspections may be supplied on the contract or purchase order if the lot is accepted.

4.5 Test methods.

4.5.1 Examination of product. Connectors shall be examined for compliance with the dimensions and workmanship requirements of this specification and in accordance with the applicable specification sheets. (see [3.1](#), [3.5](#) and [3.8](#)).

4.5.2 Insulation resistance (see [3.6.1](#)). Unmated connector assemblies shall be tested in accordance with test procedure EIA/ECA-364-21 the insulation resistance shall not exceed the values specified in [3.6.1](#). Electrification time shall not exceed 2 minutes.

4.5.3 Withstanding voltage (see [3.6.2](#)). The unmated connectors shall be tested in accordance with test procedure EIA-364-20. The connectors shall show no evidence of flashover when the applicable voltage of table III is applied between any contact and any other contact or shell and held for a period of 1 minute. For coaxial contacts, the test voltage of table III shall be applied between the center conductor and the outer conductor.

MIL-DTL-21617B

4.5.4 Vibration (see 3.6.3). Complete mated connectors shall be vibrated in accordance with test procedure EIA-364-28, test condition III, to determine conformance with 3.6.3. The following conditions shall apply:

- a. All contacts shall be wired with the appropriate size wire. At least one pair of contacts shall be connected to a suitable testing circuit with at least 0.1 ampere flowing through the contacts.
- b. Plugs and receptacles shall be held together only by the normal locking device.
 - (1) Strain relief shall be provided by the use of back shells.
 - (2) Wires shall be supported on a stationary frame not closer than 12 inches (305 mm) from the connectors.
- c. There shall be no interruption of continuity of the contact circuits.

4.5.5 Mechanical shock (specified pulse) (see 3.6.4). A mated plug and receptacle shall be tested in accordance with test procedure of EIA-364-27. The following conditions shall apply:

- a. Mounting method in accordance with test procedure EIA-364-27.
- b. Test condition A.
- c. Measurements: All contacts shall be monitored for electrical continuity during test and connectors shall be examined for evidence of failure of metallic or dielectric materials and engagement of the mated portions after test.
- d. The shock test shall be repeated 3 times in both directions of the referenced 90° axis planes (a total of 18 drops).

4.5.6 Insertion and withdrawal force (mated connectors) (see 3.6.5). The mating and unmating forces recorded during the mate and unmate cycle shall not be less than the value specified in 3.6.5. The mating and unmating operation shall be carried out in one smooth continuous motion the following conditions shall apply:

- a. A test fixture shall be provided to solidly mount both halves of the connector pair and shall closely duplicate the normal operations of mating and unmating of the connector. The test fixture shall be designed to include a force gage capable of indicating the force required to fully mate and unmate the connector halves. The fixture shall be designed to properly align the connector halves before, and during, the mating and unmating operation, eliminating any effect from connector half misalignment.
- b. The connector plug and receptacle shall be mounted on specimen plates, by means of the .120 inch (3.05 mm) diameter mounting holes. The plates shall be of such size and material as to permit adaptation to test apparatus without damage to the specimen. The plates shall simulate actual rack and panel mountings and shall be fabricated from solid sheets.

4.5.7 Durability (see 3.6.6). The complete connector assemblies shall be subjected to 500 cycles of insertion and withdrawal at a rate not exceeding 600 cycles per hour. The insertions and withdrawals shall be accomplished in a manner similar to that which the connectors shall be subjected to in service. After 500 cycles, the plug and receptacle assemblies shall conform to the durability requirements of 3.6.6.

MIL-DTL-21617B

4.5.8 Contact resistance (see 3.6.7). The contact resistance shall be tested in accordance with test procedure EIA-364-06. The following details apply:

- a. The electrical resistance of each pair of the 25 sets of mated pin and socket contacts shall be determined by measuring the voltage drop across the assembled contacts when carrying the specified current.
- b. The voltage drop shall be measured at the extreme terminal end of the contacts as shown on figure 2.

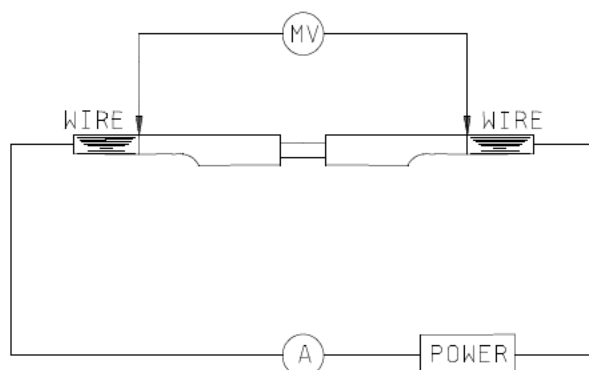

FIGURE 2. Measurement of potential.

4.5.9 Contact retention (see 3.6.8). Individual contacts in connectors shall withstand axial loads in either direction as shown in table XII. Measurements shall be made on individual contacts with all other contacts in place and the insert assembled in its shell. The loads shall be applied uniformly at approximately 1 pound (0.45 kg) per second.

TABLE XII. Contact axial loads.

Contact size	Axial load lbs min
20	7 (3.18 kg)
16	10 (4.54 kg)
12	15 (6.80 kg)
8	20 (9.07 kg)
4	20 (9.07 kg)

4.5.10 Contact separation (see 3.6.9). The average force required to separate the test pin from socket contact shall not exceed the maximum average values shown in table V, and none of the values shall be less than the minimum individual force indicated in table V. The values shall be obtained from a sample lot of 25 socket contacts. The separation force may be determined with socket contacts either in or out of their insulators. Gradually increasing loads shall be applied until the test pin properly separates from the socket. Depth of engagement shall conform to that encountered in service the following conditions shall apply:

- a. Provisions shall be made for mounting socket contacts in a suitable position for applying gradually increasing loads during withdrawal of the minimum diameter hardened steel test pins.
- b. The finish on the steel pins shall not exceed 10 microinches (0.25 μm), and the gauging end of the pin shall be rounded or chamfered.

MIL-DTL-21617B

4.5.11 Insert retention (see 3.6.10). Connector inserts shall withstand a uniformly distributed axial load of 60 pounds (27 kg) in either direction without being dislocated from their normal position in the connector shell. The insert assembly shall retain its normal position in the connector shell for the specified load the following condition shall apply:

- a. The load shall be increased gradually at a rate of approximately 1 pound (0.45 kg) per second until the specified load is reached.

4.5.12 Resistance to test prod damage (see 3.6.11). Socket contacts shall be tested in accordance with test procedure EIA-364-25. The following details shall apply:

4.5.12.1 Initial test. Eight (8) size 16 socket contacts shall meet the requirements of contact separation (see 3.5.9) after having been subjected to the following test:

- a. A test prod of hardened steel having a diameter equal to a nominal mating pin shall be inserted into each socket to .50 inch (12.7 mm), .375 inch (9.53 mm), and .25 inch (6.35 mm) depth.
- b. At each of these depths, measured from the face of the insert, a bending moment of 2 pound - force inch (226 mN m) ± 10 percent shall be applied to the prod, about the inserted end of the prod, and the connector shall be rotated in one direction through 360°, in order that a uniform force is applied to the inside surface of the socket.

Note: This test shall be performed with the socket contacts in their inserts, and the sockets locked, if necessary, to prevent rotation in the inserts during the test.

4.5.12.2 Test procedure for resistance to test prod damage. In order to insure uniform test results, the test fixture shown in the appendix shall be used to perform the tests required by 3.6.11. Procedures shall be as follows:

- a. With the weight in position for the 2 inch-pound moment and no spacers on the pin, insert the pin in a socket of an assembled receptacle or plug while the axis of the socket is in a horizontal position.
- b. With the fixture free and unsupported, rotate the receptacle or plug 360° about a horizontal axis, maintaining the socket in a horizontal position.
- c. Repeat with size 1 spacer.
- d. Repeat with size 2 spacer.
- e. After withdrawal of the fixture, the socket shall pass the contact separation force requirement of 3.6.9.

MIL-DTL-21617B

4.5.13 Moisture resistance (see [3.6.12](#)). Unmated plugs and receptacles shall be tested in accordance with test procedure EIA/ECA-364-26. The following conditions shall apply:

- a. Connectors shall be mounted in a horizontal position.
- b. After initial conditioning no measurements are required and no voltages are to be applied to connectors during exposure.
- c. After final conditioning and completion of step 6 of the final cycle, the connectors shall be removed from the cabinet and the unmated connectors shall meet the moisture resistance requirement as specified in [3.6.12](#) and table VI for the applicable service rating.

4.5.14 Air leakage, type JS receptacle (see [3.6.13](#)). While subject to a pressure differential of 30 psi (207 kilopascals) at a stabilized temperature of -55°C, type JS pressurized receptacles shall not exceed the requirement as indicated in [3.6.13](#) measured at atmospheric pressure under conditions specified in [4.2](#).

4.5.15 Thermal shock (see [3.6.14](#)). The mated connectors shall be subjected to temperature cycling in accordance with test procedure EIA-364-32, test condition B, except that the lower temperature shall be -55°C.

4.5.16 Salt spray (corrosion) (see [3.6.15](#)). The mated plugs and receptacles and 25 sets of individual pin and socket contacts shall be subjected to a salt spray (corrosion) test in accordance with test procedure EIA-364-26, test condition B. The following conditions shall apply:

- a. Upon removal, from the oven, the connectors shall be mated and shall meet the moisture resistance requirement as specified in [3.6.12](#) and table VI for the applicable service rating.

4.5.17 Solderability (see [3.6.16](#)). Solder type contacts shall be tested in accordance with method 208 of MIL-STD-202.

4.5.18 Resistance to soldering heat (see [3.6.17](#)). All connectors with solder terminations shall be tested in accordance with test procedure EIA-364-56. The connectors shall be tested in accordance with procedure 1.

5. PACKAGING.

5.1 Packaging. For acquisition purposes, the packaging requirements shall be as specified in the contract or order (see [6.2](#)). When packaging of materiel is to be performed by DoD or in-house contractor personnel, these personnel need to contact the responsible packaging activity to ascertain packaging requirements. Packaging requirements are maintained by the Inventory Control Point's packaging activities within the Military Service or Defense Agency, or within the military service's system commands. Packaging data retrieval is available from the managing Military Department's or Defense Agency's automated packaging files, CD-ROM products, or by contacting the responsible packaging activity

MIL-DTL-21617B

6. NOTES

(This section contains information of a general or explanatory nature that may be helpful, but is not mandatory.)

6.1 Intended use. The connectors covered by this specification are intended for military use because they must be able to operate satisfactory under random vibration, 100 g's of shock, and temperatures ranging from -55 to +125 degrees Celsius. Commercial electronic components are not designed to withstand such extreme and sudden environmental conditions and would experience catastrophic failure. Connectors specified in this specification use cadmium plating and are not suitable for space applications.

6.1.1 Type P, plug. Plugs are intended for use at the end of a cable mounted on panel of a unit plug-in to be mated with a panel mounted receptacle.

6.1.2 Type J, receptacle. Receptacles are intended for fixed panel mounting of unit and for use with conduit to eliminate the necessity of a conduit box.

6.1.3 Type JS, pressurized receptacle. Pressurized receptacles are intended for use on pressurized devices, and their performance requirements are determined by the particular application. They should maintain the degree of pressurization required by the equipment specification and be suitable for mating with plugs conforming to the requirements of this specification.

6.1.4 Determining wire size to be used with contact. It is intended that the wire soldered to each connector contact should be of the AWG size (or smaller diameter) corresponding to the contact size number. For example, it is intended that an AWG size 20 wire be soldered to at least a size 20 contact.

6.2 Acquisition requirements. Acquisition documents must specify the following:

- a. Title, number, and date of this specification.
- b. First article testing requirements (see [3.2](#))
- c. Packaging requirements (see [5.1](#)).
- d. PIN (see [1.2.1](#) and [3.7.1](#)).

MIL-DTL-21617B

6.3 Tin whisker growth. The use of alloys with tin content greater than 97 percent may exhibit tin whisker growth problems after manufacture. Tin whiskers may occur anytime from a day to years after, and can develop under typical operation conditions on products that use such materials. Conformal coatings applied over top of a whisker-prone surface will not prevent the formation of tin whiskers. Alloys of 3 percent lead have shown to inhibit the growth of tin whiskers.

6.4 Definitions. For purposes of this specification, the following definitions apply:

6.4.1 Insert. A connector insert is that part which holds the contacts in their proper arrangement and electrically insulates them from each other and from the shell.

6.4.2 PIN. PIN is a new term encompassing previous terms used in specification such as part number, type designator, identification numbers etc.

6.4.3 Pin. A connector pin is a male contact. It is normally connected to the "dead" side of a circuit.

6.4.4 Plug. A connector plug is that portion of the connector assembly that is normally "removable". The plug will be provided with socket contacts.

6.4.5 Receptacle. A connector receptacle is that portion of the connector assembly, which is normally "fixed", that is, rigidly attached to a supporting surface. It will be provided with pin contacts.

6.4.6 Shell. A connector shell is the outside case into which the insert and contacts are assembled.

6.4.7 Socket. A connector socket is a female contact. It is normally connected to the "live" side of a circuit.

6.5 Environmentally preferable material. Environmentally preferable materials should be used to the maximum extent possible to meet the requirements of this specification. As of the dating of this document, the U.S. Environmental Protection Agency (EPA) is focusing efforts on reducing 31 priority chemicals. The list of chemicals and additional information is available on their website at <http://www.epa.gov/osw/hazard/wastemin/priority.htm>. Included in the list of 31 priority chemicals are cadmium, lead, and mercury. Use of these materials should be minimized or eliminated unless needed to meet the requirements specified herein (see [section 3](#)).

6.6 Subject term (key word) listing.

- Aluminum
- Air leakage
- Cadmium
- Coaxial contacts
- Contact separation
- Gold
- Lead
- Nickel
- Solder cup
- Test prod
- Tin

MIL-DTL-21617B

6.7 Superseding PIN. The following is an example of the former PIN and the superseding PIN herein.

Superseded PIN

JM023A

Superseding PIN

M21617/14JM023A

6.8 Changes from previous issue. The margins of this specification are marked with vertical lines to indicate where changes from the previous issue were made. This was done as a convenience only and the Government assumes no liability whatsoever for any inaccuracies in these notations. Bidders and contractors are cautioned to evaluate the requirements of this document based on the entire content irrespective of the marginal notations and relationship to the last previous issue.

MIL-DTL-21617B

APPENDIX A

TEST FIXTURE

A.1 SCOPE

A.1.1 Scope. This appendix details the test probes/fixtures covered by this specification. The information contained herein is intended for compliance. This appendix is a mandatory part of this specification.

A.2 APPLICABLE DOCUMENTS

(This section is not applicable to this appendix.)

A.3 PROCEDURE

A.3.1 Test fixtures.

A.3.2 Supply of test fixtures. The laboratory or activity that performs the tests will be responsible for the supply of all necessary test fixtures and gauges.

A.3.3 Order of precedence. In the event of a conflict between the text of this appendix and the references cited herein, the text of this appendix shall take precedence.

MIL-DTL-21617B

APPENDIX A

A.3.4 Resistance to test prod test fixture. The test fixture shall be as shown on figure A-1.

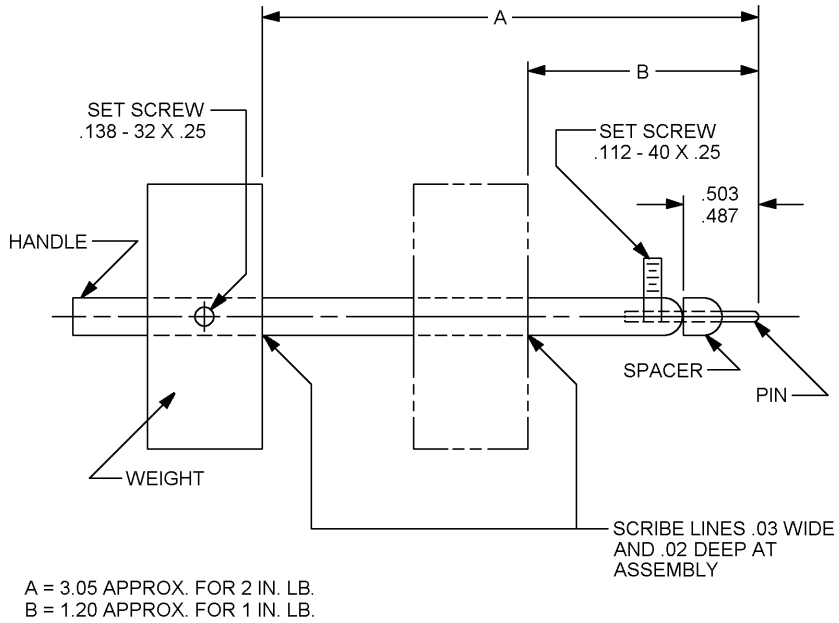

ASSEMBLY

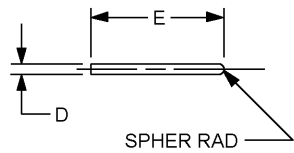

MATERIAL: HARDENED STEEL

PIN

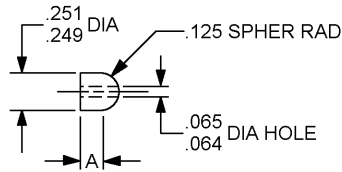

MATERIAL: BRASS

SPACERS

SIZE 1, A = .251
.248

SIZE 2, A = .126
.124

Contact size	D (mm)	E (mm)
16	.0633 ± .0002 (1.608 ± 0.005)	.875 ± .002 (25.23 ± 0.05)

FIGURE A-1. Test fixture resistance to test prod damage.

MIL-DTL-21617B

APPENDIX A

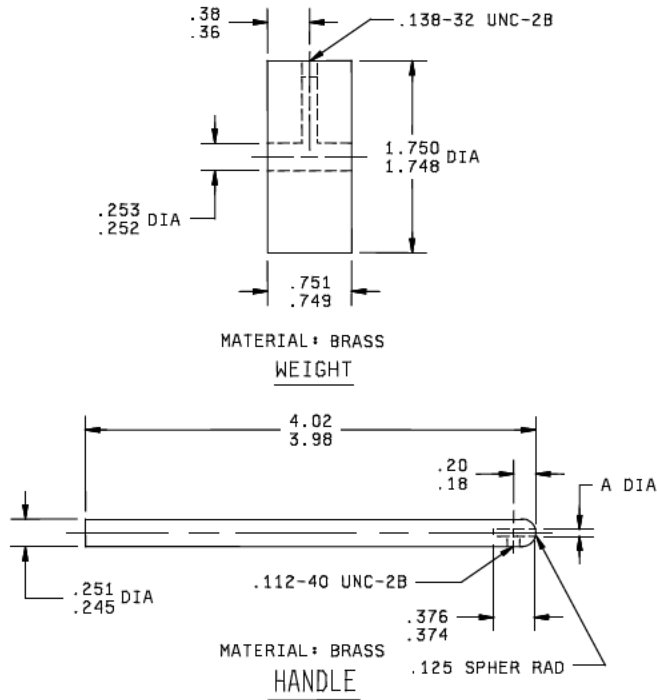

Contact size	A
16	.064 +.001, -.000 (1.63 + 0.025, -0.00 mm)

Inches	mm	Inches	mm	Inches	mm	Inches	mm
.064	1.62	.18	4.5	.252	6.40	.503	19.05
.065	1.65	.20	5.1	.253	6.43	1.748	44.40
.112	2.84	.245	6.22	.36	9.1	1.750	44.45
.124	3.15	.248	6.30	.374	9.50	1.20	30.48
.125	3.18	.249	6.32	.376	9.55	3.05	77.47
.126	3.20	.25	6.35	.38	9.7	3.98	101.09
.138	3.50	.251	6.38	.487	12.37	4.02	102.11

NOTES:

1. Dimensions are in inches.
2. Metric equivalents are given for information only.
3. Unless otherwise specified, tolerance is $\pm .005$ (0.13 mm).

FIGURE A-1. Test fixture resistance to test prod damage - Continued.

MIL-DTL-21617B

CONCLUDING MATERIAL

Custodians:

Army – CR
Navy – EC
Air Force - 85
DLA – CC

Preparing activity:
DLA – CC

(Project 5935-2011-126)

Review activities:

Army - AV, MI

NOTE: The activities listed above were interested in this document as of the date of this document. Since organizations and responsibilities can change, you should verify the currency of the information above using the ASSIST Online database at <https://assist.daps.dla.mil/>.