

INCH-POUND

MIL-DTL-19648D  
 15 February 2002  
 SUPERSEDING  
 MIL-R-19648C  
 27 October 1986

## DETAIL SPECIFICATION

RELAYS, TIME DELAY, THERMAL,  
 GENERAL SPECIFICATION FOR

Inactive for new design after the date of this document. No superseding specification.

This specification is approved for use by all Departments and Agencies of the Department of Defense.

## 1. SCOPE

1.1 Scope. This specification covers the general requirements for thermal, time delay relays for use in electrical applications. Relays covered by this specification are capable of meeting the electrical and environmental requirements when mounted directly to the structure of aircraft, missile, spacecraft, ship, and other primary vehicles or in ground support and shipboard equipment. Other ratings may be as specified (see 3.1).

1.2 Classification.

1.2.1 Military part number. The military part number is to consist of the letter "M," the basic number of the specification sheet, and an assigned dash number (see 3.1) as shown in the following:

M19648	/1	-101
Specification designator	Specification sheet number	Dash number

1.2.2 Levels and classes. Relays covered by this specification are to be of the following levels and classes, as specified (see 3.1 and 6.2.1).

1.2.2.1 Shock. The shock level is to be in accordance with table I as specified (see 3.1 and 6.2.1).

TABLE I. Shock level.

Level	Test condition	Applicable test method of MIL-STD-202
1	G	213
2	I	213
3	Hi-impact	207

Beneficial comments (recommendations, additions, deletions) and any pertinent data which may be of use in improving this document should be addressed to Defense Supply Center, Columbus, Post Office Box 3990, Columbus, OH 43216-5000, by using the Standardization Document Improvement Proposal (DD Form 1426) appearing at the end of this document or by letter.

AMSC N/A  
 DISTRIBUTION STATEMENT A. Approved for public release; distribution is unlimited.

FSC 5945

## MIL-DTL-19648D

1.2.2.2 Temperature class. The temperature class is to be in accordance with table II as specified (see 3.1 and 6.2.1).

TABLE II. Temperature class.

Class	Operating ambient temperature range, °C
A	-55 to +85
B	-65 to +125

1.2.2.3 Vibration. The vibration levels is to be in accordance with table III as specified (see 3.1 and 6.2.1).

TABLE III. Vibration level.

Level	Acceleration value	Frequency range	MIL-STD-202	
			Method	Condition
1	10G	10 to 55 Hz	201	
2	10G	10 to 500 Hz	204	A
3	15G	10 to 2000 Hz	204	B
4	20G	10 to 2000 Hz	204	D

## 2. APPLICABLE DOCUMENTS

2.1 General. The documents listed in this section are specified in sections 3 and 4 of this specification. This section does not include documents cited in other sections of this specification or recommended for additional information or as examples. While every effort has been made to ensure the completeness of this list, document users are cautioned that they must meet all specified requirements documents cited in sections 3 and 4 of this specification, whether or not they are listed.

### 2.2 Government documents.

2.2.1 Specifications, standards, and handbooks. The following specifications, standards, and handbooks form a part of this document to the extent specified herein. Unless otherwise specified, the issues of these documents are those listed in the issue of the Department of Defense Index of Specifications and Standards (DoDISS) and supplement thereto, cited in the solicitation (see 6.2).

#### STANDARDS

##### DEPARTMENT OF DEFENSE

- MIL-STD-130 - Identification Marking of US Military Property.
- MIL-STD-202 - Test Methods for Electronic and Electrical Component Parts.
- MIL-STD-889 - Dissimilar Metals.
- MIL-STD-1285 - Marking of Electrical and Electronic Parts.

(Unless otherwise indicated, copies of the above specifications, standards, and handbooks are available from the Document Automation and Production Service, Building 4D (DPM-DODSSP), 700 Robbins Avenue, Philadelphia, PA 19111-5094.)

2.3 Order of precedence. In the event of a conflict between the text of this document and the references cited herein (\* except for related associated specifications, specification sheets, or MS

## MIL-DTL-19648D

sheets), the text of this document takes precedence. Nothing in this document, however, supersedes applicable laws and regulations unless a specific exemption has been obtained.

### 3. REQUIREMENTS

3.1 Specification sheets. The individual item requirements shall be as specified herein and in accordance with the applicable specification sheet. In the event of any conflict between the requirements of this specification and the specification sheet, the latter shall govern.

3.1.1 Relays not covered by specification sheets. Performance criteria shall be as specified herein and in accordance with the individual service's or manufacturer's drawing. In the event of any conflict between the requirements of this specification and the applicable drawing, the latter shall govern.

3.2 First article. When specified in the contract or purchase order, a sample shall be subjected to first article inspection (see 4.4 and 6.3).

3.2.1 Inspection of relays not covered by specification sheets. Relays furnished under this specification and not covered by specification sheets shall be products which have been tested and have passed the inspection specified in 4.5.

3.3 Material. Material shall be as specified herein. However, when a definite material is not specified, a suitable material shall be used which will enable the relay to conform to the performance requirements of this specification. Acceptance or approval of any constituent material shall not be construed as a guaranty of the acceptance of the finished product.

3.3.1 Metals. Metals shall be of a corrosion-resistant type or shall be plated or treated to resist corrosion. Zinc plating, cadmium plating, or unfused pure tin plating shall not be used on internal parts of hermetically sealed relays. Zinc plating or cadmium plating shall not be used externally. Unfused tin plating shall have a plating thickness of 200 microinches minimum if used for external parts.

3.3.1.1 Dissimilar metals. When dissimilar metals (as defined in MIL-STD-889, paragraph 3.1) are used in intimate contact with each other, protection against electrolysis and corrosion shall be provided. The use of dissimilar metals which, in contact, tend toward active electrolytic corrosion (particularly brass, copper, or steel used in contact with aluminum or aluminum alloy) is not acceptable. However, metal-plating or metal-spraying of dissimilar base metals to provide similar or suitable abutting surfaces is permitted. The use of dissimilar metals separated by a suitable insulating material is also permitted.

3.4 Design and construction. The relays shall be of the design, construction, and physical dimensions specified (see 3.1 and 6.2.1).

3.4.1 Heater winding. The heater winding shall be electrically insulated from the case or frame.

3.4.1.1 Rated heater voltage (see 6.6.1). Rated heater voltage shall be as specified (see 3.1 and 6.2.1).

3.4.2 Contact arrangement and contact rating. Contact arrangement and contact rating shall be as specified (see 3.1 and 6.2.1). The rating shall be specified in current and voltage, ac or dc; and type of load, resistive, inductive, or tungsten lamp. For ac ratings, frequency shall be 60 Hz unless otherwise specified.

3.4.3 Terminals. The terminals shall be of the design specified (see 3.1 and 6.2.1).

## MIL-DTL-19648D

3.4.3.1 Solder-lug terminals. Unless otherwise specified (see 3.1 and 6.2.1), solder-lug terminals used for a 2-ampere rating or less shall be designed to allow the securing of two or more AWG No. 20 wires. Terminals used for more than a 2-ampere rating shall be designed to allow the securing of three or more wires, the size of which shall be as specified (see 3.1 and 6.2.1).

3.4.4 Adjustments. Relays having adjustable thermal settings shall be so designed that the setting of any relay adjustment will not be altered by any tests specified herein.

3.4.5 Weight. Weight of the relay shall be as specified (see 3.1 and 6.2.1).

3.5 Solderability. When relays are tested as specified in 4.7.2, 95 percent of the total length of fillet, which is between the standard wrap wire and the terminal, shall be tangent to the surface of the terminal being tested. There shall be no pinholes, voids, etc. A ragged or interrupted line at the point of tangency between the fillet and the terminal under test shall be considered a defect. After the test there shall be no evidence of fracture, loosening of parts, or any other mechanical failure of relays.

### 3.6 Electrical characteristics.

3.6.1 Contact resistance. When tested as specified in 4.7.3.1, contact resistance shall meet the requirements of 3.6.1.1 and 3.6.1.2. All measurements shall be taken from the outside of the header.

3.6.1.1 At rated load. Initial contact resistance and the resistance measured subsequent to any test, with exception of life test, shall not exceed 0.050 ohm; during and after life test, resistance shall not exceed 0.150 ohm.

3.6.1.2 At minimum current (0.100 ampere). Initial contact resistance and the resistance measured subsequent to any test, with the exception of life test, shall not exceed 0.5 ohm; during and after life test, resistance shall not exceed 1.0 ohm.

3.6.2 Normal operate time (see 6.6.2). When relays are tested as specified in 4.7.3.2, normal operate time shall be as specified (see 3.1 and 6.2.1).

3.6.2.1 Normal operate time tolerance (see 6.6.3). Relays shall meet the requirements of 3.6.2.1.1 or 3.6.2.1.2, as applicable.

3.6.2.1.1 During and after life test (except heater life). The timing change from the initial operate time shall not exceed two times the specified normal operate time tolerance (see 3.1) during and after the tests specified in 4.7.16.1 and 4.7.16.2.

3.6.2.1.2 After heater life and other tests. The tolerance on normal operate time shall be increased by 50 percent of normal operate time tolerance (see 3.1) after exposure to any one of the following tests:

- Acceleration
- Thermal shock
- Overvoltage
- Shock
- Vibration
- Heater life

After the relay has been subjected to two or more of these tests, normal operate time tolerance shall be increased to two times the normal operate time tolerance.

## MIL-DTL-19648D

3.6.3 Minimum operate and minimum hold-in voltage (see 6.6.4 and 6.6.5). When tested as specified in 4.7.3.3, relays shall operate in not more than four times normal operate time (see 3.1). After the relay operates, normally open (NO) contacts shall remain closed and normally closed (NC) contacts shall remain open. A slight hesitation at the moment of operation shall not be interpreted as releasing.

3.6.4 Release time (when specified). When relays are tested as specified in 4.7.3.4, the release time shall be as specified (see 3.1).

3.6.5 Recovery time (when specified). When relays are tested as specified in 4.7.3.5, recovery time shall be as specified (see 3.1).

3.7 Seal. When tested as specified in 4.7.4, sealed relays shall meet the requirements of 3.7.1 or 3.7.2, as applicable (see 3.1 and 6.2.1).

3.7.1 Seal test I (applicable to hermetically sealed relays). When relays are tested as specified in 4.7.4.1, there shall be no leakage in excess of  $1 \times 10^8$  standard atmospheric cubic centimeters per second ( $\text{atm cm}^3/\text{s}$ ).

3.7.2 Seal test II (applicable to nonhermetically sealed relays). When relays are tested as specified in 4.7.4.2, there shall be no leakage.

3.8 Dielectric withstanding voltage. When relays are tested as specified in 4.7.5, there shall be no evidence of arcing, flashover, or electrical breakdown; leakage current shall not exceed 1.0 milliamperes.

3.9 Insulation resistance. When relays are tested as specified in 4.7.6, the insulation resistance between insulated terminals and between any insulated terminals and case or frame shall be 100 megohms minimum.

3.10 Terminal strength (solder-lug and plug-in terminals). When relay terminals are tested as specified in 4.7.7, there shall be no loosening or breakage of terminals, cracking or flaking of glass insulators other than crazing or chipping of the glass meniscus, or any other damage. There shall be no deterioration of relay performance beyond specified limits. After terminal strength test, hermetically sealed relays shall meet the sealing requirements specified in 3.7.

3.11 Thermal shock. When relays are tested as specified in 4.7.8, normal operate time tolerance before the test and during the high and low temperature tests shall be as specified (see 3.1). Following the thermal shock test, normal operate time tolerance shall be as specified in 3.6.2.1.2.

3.12 Shock. When relays are tested as specified in 4.7.9, there shall be no evidence of mechanical or electrical damage, nor shall the test impair the normal operation of the relay. There shall be no closing of open contacts or opening of closed contacts in excess of 10 microseconds. Following the shock test, contact resistance and normal operate time tolerance shall be as specified in 3.6.1 and 3.6.2.1.2, respectively.

3.13 Centrifugal acceleration (when applicable, see 3.1 and 6.2.1). When tested as specified in 4.7.10, relays shall meet the requirements of 3.13.1 or 3.13.2, as applicable (see 3.1 and 6.2.1).

3.13.1 Acceleration test 1. When relays are tested as specified in 4.7.10.1, normal operate time shall be as specified (see 3.1), under the constant acceleration. After the test, normal operate time and normal operate time tolerance shall be as specified (see 3.1 and 3.6.2.1.2).

3.13.2 Acceleration test 2. When relays are tested as specified in 4.7.10.2, NO contacts shall remain

## MIL-DTL-19648D

open and NC contacts shall remain closed at all times during the test while the relay is not energized. NO contacts shall remain closed and NC contacts shall remain open at all times while the relay is saturated at rated heater input. After the test, normal operate time and normal operate time tolerance shall be as specified (see 3.1 and 3.6.2.1.2).

3.14 Overvoltage. When relays are tested as specified in 4.7.11, relays shall not be damaged and normal operate time shall be as specified (see 3.1). Following overvoltage test, normal operate time tolerance and insulation resistance shall be as specified in 3.6.2.1.2 and 3.9, respectively.

3.15 Vibration. When tested as specified in 4.7.12 for the level specified (see 1.2.2.3, 3.1, and 6.2.1), there shall be no contact chatter in excess of 10 microseconds at any time in either the stabilized deenergized, or in the saturated condition. At rated heater input and at maximum vibration frequency (or resonant frequency) (see 4.7.12.1, 4.7.12.2, and 4.7.12.3), the operate time at the first sign of chatter shall be not less than 80 percent of normal operate time and the duration of the chatter shall be not more than 25 percent of the normal time. Following the vibration test, the insulation resistance at room temperature, contact resistance, normal operate time tolerance and dielectric withstanding voltage at sea level shall be as specified in 3.9, 3.6.1, 3.6.2.1.2 and 4.7.5.1 respectively.

3.16 Moisture resistance. When tested as specified in 4.7.13, relays shall show no evidence of breaking, cracking, crazing, spalling, or loosening of terminals. Immediately after the tenth moisture-resistance cycle, at a relative humidity of 90 to 95 percent and a temperature of 25°C, the insulation resistance shall be at least 1 megohm. After the moisture-resistance test and after 24 hours conditioning at room ambient temperature and humidity, the insulation resistance of the relays shall be at least 50 megohms and the contact resistance and normal operate time shall be as specified (see 3.6.1 and 3.1). The relays shall have no corrosion of the case or terminals as a result of the moisture-resistance test. Slight discoloration no longer than the diameter of the terminal is permitted at the junction of the terminal and the header.

3.17 Overload. When tested as specified in 4.7.14, the contact resistance following testing shall not exceed 0.100 ohm and the normal operate time shall be as specified (see 3.1).

3.18 Salt spray (corrosion). When tested as specified in 4.7.15, there shall be no evidence of corrosion, no peeling, chipping, or blistering of the finish, nor exposure of base metal. Slight discoloration no longer than the diameter of the terminal is permitted at the junction of the terminal and the header.

3.19 Life. When tested as specified in 4.7.16, relays will not operate erratically. Contact resistance and insulation resistance at room ambient shall be as specified in 3.6.1 and 3.9, respectively. At the intervals specified and at the end of life test, normal operate time tolerance shall be as specified in 3.6.2.1.1 and 3.6.2.1.2.

3.20 Marking. Unless otherwise specified (see 3.1 and 6.2), the relays shall be marked in accordance with MIL-STD-130 and shall include the following:

- a. Manufacturer's name or code symbol in accordance with MIL-STD-1285.
- b. Date code in accordance with MIL-STD-1285.
- c. Heater voltage.
- d. Specification part number.

MIL-DTL-19648D

- e. Contact rating (volts and amperes).
- f. Circuit diagram.
- g. Time delay rating.

3.20.1 Military part number. The military part number shall be in accordance with 1.2.1.

3.21 Recycled, recovered, or environmentally preferable materials. Recycled, recovered, or environmentally preferable materials should be used to the maximum extent possible provided that the material meets or exceeds the operational and maintenance requirements, and promotes economically advantageous life cycle costs.

3.22 Workmanship. Relays shall be processed in such a manner as to be uniform in quality and shall be free from cracked or displaced parts, sharp edges, burrs, and other defects that will affect life, serviceability, or appearance.

#### 4. VERIFICATION

4.1 Classification of inspections. The inspection requirements specified herein are classified as follows:

- a. Materials inspection (see 4.2).
- b. First article inspection (see 4.4).
- c. Inspection of relays not covered by specification sheets (see 4.5).
- d. Conformance inspection (see 4.6).

4.2 Materials inspection. Materials inspection shall consist of certification supported by verifying information that the materials used in fabricating the relays are in accordance with the applicable referenced specification or requirements prior to such fabrication.

4.3 Inspection conditions. Unless otherwise specified herein, all inspections shall be performed in accordance with the test conditions specified in the "GENERAL REQUIREMENTS" of MIL-STD-202.

4.4 First article inspection. First article inspection (see 3.2) shall be performed by the supplier after award of contract and prior to production or delivery at a facility acceptable to the Government. First article inspection shall be performed on sample units which have been produced with equipment and procedures normally used in production. First article approval is valid only on the contract or purchase order under which it is granted, unless extended by the Government to other contracts or purchase orders.

4.4.1 Sample size. The number of relays to be subjected to first article inspection shall be as specified in table IV.

4.4.2 Inspection routine. The sample shall be subjected to the inspections specified in table IV, in the order shown. All sample units shall be subjected to the inspection, except solderability, of group I. The sample shall then be divided as specified in table IV for groups II and III and subjected to the inspection for their particular group.

## MIL-DTL-19648D

TABLE IV. First article inspection.

Inspection	Requirement paragraph	Test method paragraph	Number of sample units to be inspected	Number of failures
<u>Group I</u>			11	} 1 <u>6/</u>
Visual and mechanical examination 1/	3.1, 3.4, 3.20, 3.21	4.7.1		
Solderability 2/	3.5	4.7.2		
Electrical characteristics	3.6.1 thru 3.6.5	4.7.3.1 thru		
Seal	3.7	4.7.3.5		
Dielectric withstanding voltage	3.8	4.7.4		
Insulation resistance	3.9	4.7.5 4.7.6		
<u>Group II</u>			4	
Thermal shock 3/	3.11	4.7.8		
Shock 3/	3.12	4.7.9		
Centrifugal acceleration (when applicable) 3/	3.13	4.7.10		
Overvoltage	3.14	4.7.11		
Vibration 3/	3.15	4.7.12		
Overload	3.17	4.7.14		
Moisture resistance	3.16	4.7.13		
Terminal strength	3.10	4.7.7		
Seal test II	3.7.2	4.7.4 and 4.7.4.2		
Dielectric withstanding voltage	3.8	4.7.5		
Insulation resistance	3.9	4.7.6		
<u>Group III</u>				0
Life 3/ 4/	3.19	4.7.16	3	
Salt spray 5/	3.18	4.7.15		
Life (heater)	3.19	4.7.16.3	3	

1/ One unsealed sample for internal examination only.

2/ Two sample units only.

3/ For operate time tolerance, see 3.1 and 3.6.2.1.

4/ Two sample units per load rating but not less than three total.

5/ Use heater life samples for salt spray.

6/ One noncatastrophic failure allowed for single submission. Two noncatastrophic failures for group submission.

4.4.3 Failures. One noncatastrophic failure is allowed for single submission inspection of table IV. Two noncatastrophic failures are allowed for group submission. Noncatastrophic failures are as follows:

- a. Dielectric withstanding voltage not less than 75 percent of initial rating.
- b. Insulation resistance not less than 50 megohms.
- c. Contact resistance not more than two times rated value.



## MIL-DTL-19648D

- d. Normal operate time within  $\pm$  four times operate time tolerance or  $\pm 40$  percent of normal operate time, whichever is less.

Failures exceeding the above limits shall be cause for refusal to grant first article approval.

4.5 Inspection requirements for items not covered by specification sheets. Inspection requirements for items not covered by specification sheets (see 3.2.1) shall be performed by the supplier, after award of contract, and prior to production, at a laboratory acceptable to the Government (see 6.2.1). The inspection shall be performed on sample units which have been produced with equipment and procedures normally used in production. Unless otherwise specified (see 6.2.1), the samples and inspection routine shall be as specified in 4.4.1, 4.4.2, and table IV. Approval of inspection requirements for items not covered by specification sheets is valid only on the contract or purchase order under which approval is granted, unless extended by the Government to other contracts or purchase orders.

4.6 Conformance inspection.

4.6.1 Inspection of product for delivery. Inspection of product for delivery shall consist of group A inspection.

4.6.1.1 Inspection lot. An inspection lot shall consist of all relays covered by a single specification sheet, produced under essentially the same conditions, and offered for inspection at one time.

4.6.1.2 Group A inspection. Group A inspection shall consist of the inspections specified in table V, in conjunction with table VI, in the order shown.

TABLE V. Group A inspection.

Inspection	Requirement paragraph	Test method paragraph	Sampling plan
Visual and mechanical examination (external)	3.1, 3.4, 3.5, 3.20, 3.22	4.7.1.1	See table VI
Normal operate time	3.6.2	4.7.3.2	} See table VI
Release time (when specified)	3.6.4	4.7.3.4	
Recovery time (when specified)	3.6.5	4.7.3.5	
Contact resistance	3.6.1	4.7.3.1	
Seal <sup>1/</sup>	3.7	4.7.4	
Dielectric withstanding voltage	3.8	4.7.5	
Insulation resistance	3.9	4.7.6	}

<sup>1/</sup> Performed prior to final seal.

4.6.1.2.1 Sampling plan. A sample of parts shall be randomly selected in accordance with table VI, if one or more defects are found, the lot shall be rescreened and defects removed. After screening and removal of defects, a new sample of parts shall be randomly selected in accordance with table VI, if one or more defects are found in the second sample, the lot shall be rejected and shall not be supplied to this specification.

## MIL-DTL-19648D

Table VI. Group A inspection.

Lot size		Electrical Characteristics <sup>1/</sup>	Visual and Mechanical Examination
2 to	12	100 percent	100 percent
13 to	125	100 percent	13
126 to	150	125	13
151 to	280	125	20
281 to	500	125	29
501 to	1,200	125	34
1,201 to	3,200	125	42
3,201 to	10,000	192	50
10,001 to	35,000	294	60
35,001 to	150,000	294	74
150,001 to	500,000	345	90
500,001 and over		435	102

<sup>1/</sup> Electrical characteristics would, in this case, include: normal operate time, release time (when specified), recovery time (when specified), contact resistance, seal, dielectric withstanding voltage, and insulation resistance.

#### 4.7 Methods of inspection.

##### 4.7.1 Visual and mechanical examination.

4.7.1.1 External. Relays shall be examined to verify that the external design and construction, physical dimensions, weight, and marking are in accordance with the applicable requirements (see 3.1, 3.4, 3.5, 3.20 and 3.22.)

4.7.1.2 Internal. Relays shall be disassembled and examined to verify that the internal design and construction are in accordance with the applicable requirements (see 3.1 and 3.4.).

4.7.2 Solderability (see 3.5). Relays shall be tested in accordance with method 208 of MIL-STD-202. The following details shall apply:

- a. Number of terminations - Two per relay.
- b. Solder dip - Applicable.
- c. Examination of terminations - Applicable.

##### 4.7.3 Electrical characteristics.

4.7.3.1 Contact resistance (see 3.6.1). Relays shall be tested in accordance with method 307 of MIL-STD-202. The following details shall apply:

- a. Method of connection - Connection jigs or other suitable means.
- b. Test current:
  - (1) Normal bridge current if Kelvin bridge is used.

## MIL-DTL-19648D

(2) Maximum rated current if voltmeter-ammeter method is used.

c. Maximum open-circuit test voltage - 25 percent of rated contact voltage, or 6 volts, whichever is lower.

d. Number of activations prior to measurement - Not applicable.

e. Number of test activations - Three.

f. Number of measurements per activation - One.

4.7.3.2 Normal operate time (NOT) (see 3.6.2). Rated heater voltage, as specified (see 3.1 and 6.2.1), shall be applied until NO contacts close or NC contacts open. The time of operation shall be measured using a suitable circuit such as shown in figure 1. The timer shall be electronic for time delays specified as less than 0.1 second. Synchronous motor-driven timers may be used for time delays specified as 0.1 second or longer. The relay shall be at a stabilized ambient temperature of  $25^{\circ}\text{C} \pm 5^{\circ}\text{C}$ .

4.7.3.3 Operate time and hold in at minimum voltage. The relay shall be subjected in turn, to maximum and minimum rated temperature. After two hours in each condition and while still being subjected to the condition, 83 percent of nominal heater voltage shall be applied to the relay heater. The time interval between application of heater voltage and operation of the contacts, shall be measured. Application of the heater voltage shall be continued for 15 times normal operate time plus 5 minutes.

4.7.3.4 Release time (when specified)(see 3.6.4).

4.7.3.4.1 Instant release time (see 6.6.7). When specified (see 3.1), the instant release time shall be measured using generally the same equipment as for normal operate time, keeping in mind that for short intervals, automatic timing means are necessary. In any event, the heater power shall be cut off automatically and instantly at the end of normal operate time by means of a high-speed magnetic-relay, operated by the thermal relay under test. The time interval shall be measured from this cut-off point until NO contacts reopen or NC contacts reclose (see figure 2.).

4.7.3.4.2 Saturate release time (SRT) (see 6.6.8). When specified (see 3.1), the saturate release time shall be measured using generally the same equipment as for normal operate time. The relay shall be saturated at rated heater power for 15 times normal operate time plus 5 minutes before power is cut off. The time interval shall be measured from cut-off of heater power until NO contacts reopen, or NC contacts reclose (see figure 1.).

## MIL-DTL-19648D

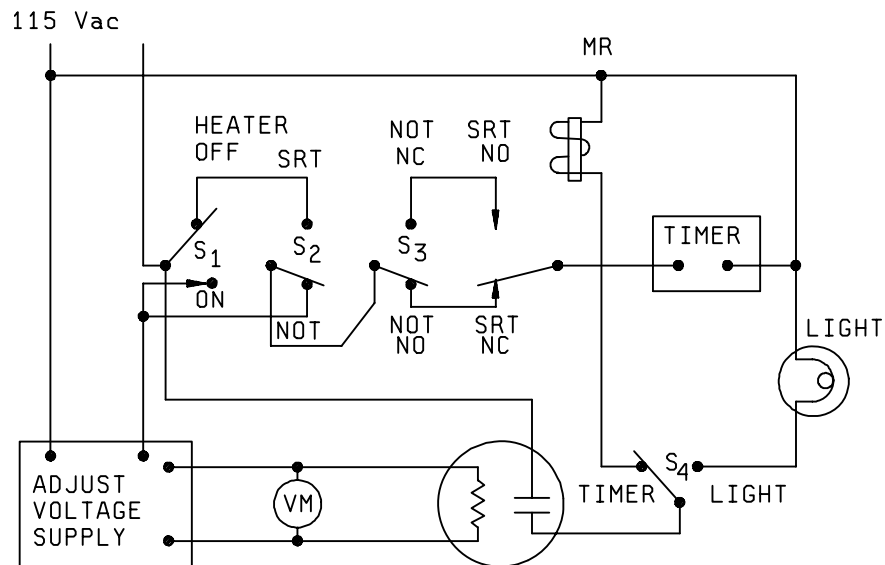

NOTE: Set switches S2, S3, and S4 as required, then initiate test with switch S1.

FIGURE 1. Timing circuit for normal operate time and saturate release time for NO and NC relays.

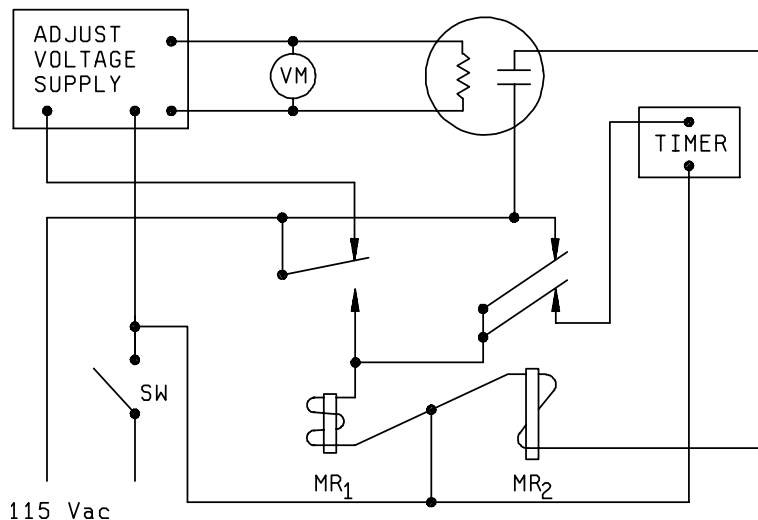

FIGURE 2. Instant release timing circuit (for NO relays only).

#### 4.7.3.5 Recovery time (when specified) (see 3.6.5).

4.7.3.5.1 Instant recovery time (see 6.6.9). When specified (see 3.1), start by measuring normal operate time as specified in 4.7.3.2. Power to heater shall be cut off automatically (as for instant release time) at instant when relay operates, and the relay shall be allowed to cool for the instant recovery time permitted by the specification sheet. At end of this time, the heater shall be reenergized and recovery operate time shall be measured. This shall be not less than 85 percent of normal operate time. Input voltage to the heater shall be the same for both normal and recovery operate time.

## MIL-DTL-19648D

4.7.3.5.2 Saturate recovery time (see 6.6.10). When specified (see 3.1), start by measuring normal operate time as specified in 4.7.3.2. Excitation of heater shall be continued at rated voltage for 15 times normal operate time plus 5 minutes. Heater power shall be cut off and the relay shall be allowed to cool for saturate recovery time permitted by the specification sheet. At end of this time, the heater shall be reenergized. The recovery operate time measured shall be not less than 85 percent of normal operate time. Input voltage to the heater shall be the same for both normal and recovery operate time.

4.7.4 Seal (see 3.7). Relays shall be tested in accordance with method 112 of MIL-STD-202. The following details shall apply:

4.7.4.1 Seal test I.

- a. Test condition C.
- b. Procedure I or III.
- c. Degree of leakage rate sensitivity - See 3.7.1.
- d. Measurements after test - Not applicable.

4.7.4.2 Seal test II.

- a. Test condition B.
- b. Measurements after test - Not applicable.

4.7.5 Dielectric withstanding voltage (see 3.8).

4.7.5.1 At atmospheric pressure. Relays shall be tested in accordance with method 301 of MIL-STD-202. The following details shall apply:

- a. Magnitude of test voltage, nature of potential and points of application.
  - (1) Sea level - 1,000  $\pm$ 50 V rms, 60 Hz, between any switching circuits and heater, between any switching circuits and case, and between heater and case. (For heaters or contacts rated at 115 V, 400 Hz, or above, this test voltage shall be 1,250  $\pm$ 50 V rms, 60 Hz).
  - (2) Sea level - 500  $\pm$ 10 V rms, 60 Hz between open contacts within all switching circuits in the energized and unenergized positions.
- b. Leakage current shall be monitored.

4.7.5.2 At reduced barometric pressure. Relays shall be tested as specified in 4.7.5.1a (1) and in accordance with method 105 of MIL-STD-202. The following details shall apply:

- a. Method of mounting - Normal mounting means.
- b. Test-condition letter - D, unless otherwise specified (see 3.1 and 6.2.1).
- c. Tests during subjection to reduced pressure - Same as 4.7.5.1 except test voltage shall be 350  $\pm$ 10 volts, 60 Hz between all points as specified in 4.7.5.1a (2).

## MIL-DTL-19648D

d. Leakage current shall be monitored.

4.7.6 Insulation resistance (see 3.9). The insulation resistance shall be measured in accordance with method 302 of MIL-STD-202. The following details shall apply:

a. Test condition letter - A.

b. Points of measurement shall be:

1. Between heater terminals, commonly connected, and case.
2. Between each NO contact and case.
3. Between each movable or "common" contact (or NC contact) and case with heater deenergized.
4. Between all contact terminals, commonly connected and the heater terminals.

4.7.7 Terminal strength (see 3.10). The terminal strength shall be measured as specified in 4.7.7.1, 4.7.7.2, or 4.7.7.3, as applicable.

4.7.7.1 Solder terminals, 0.047 inch diameter or less. Each terminal shall be twisted  $45 \pm 5$  degrees clockwise,  $90 \pm 10$  degrees counterclockwise, and then  $45 \pm 5$  degrees clockwise. The twisting force shall be applied at the point where connections would normally be made. Following the twist test, the applicable pull force specified in table VII shall be applied to each terminal at the point where connections would normally be made. The pull shall be applied in any one direction  $45 \pm 5$  degrees from the normal axis of the terminal for a period of 15 to 30 seconds. Terminals shall be returned to their normal position.

TABLE VII. Pull force.

Terminal diameter (inches)	Pull force (pounds)
0.035 - 0.047	$5 \pm 0.5$
0.023 - 0.0349	$3 \pm 0.3$
Less than 0.023	$2 \pm 0.2$

4.7.7.2 Plug-in terminals, 0.047 inch diameter or less. Each terminal shall be bent 20 to 30 degrees in both directions from the normal axis of the terminal in a given plane and after returning it to normal, the terminal shall be bent 20 to 30 degrees in both directions perpendicular to the previous plane. The terminals shall be returned to their normal positions. Following the bend test, the applicable pull force specified in table VII shall be applied to each terminal for a period of 15 to 30 seconds.

4.7.7.3 Solder and plug-in terminals greater than 0.047 inch diameter. A pull force of  $10 \pm 1$  pounds shall be applied to each terminal in any one direction  $45 \pm 5$  degrees from the normal axis of the terminal for a period of 15 to 30 seconds. The force shall be applied to solder terminals at the point where connections would normally be made or to plug-in terminals in the last one-fourth of length.

4.7.8 Thermal shock (see 3.11). Relays shall be tested in accordance with method 107 of MIL-STD-202. The following details and exceptions shall apply:

- a. Test condition - A (for class A relays);  
B (for class B relays).

## MIL-DTL-19648D

- b. Measurements before, during, and after test - Before and after thermal shock test, normal operate time shall be tested as specified in 4.7.3.2. During the last cycle of the test, the relay shall be subjected to the low and high temperature extremes for 90 minutes each with the heater unenergized. Within the last 10 minutes of each 90-minute period, normal operate time shall be tested as specified in 4.7.3.2, except ambient temperature shall be as specified above.

4.7.9 Shock (see 3.12). Relays shall be tested in accordance with 4.7.9.1 or 4.7.9.2, as specified (see 3.1 and 6.2.1).

4.7.9.1 Method I. Relays shall be tested in accordance with method 213 of MIL-STD-202. The following details and exceptions shall apply:

- a. Mounting - Normal mounting means.
- b. Test condition level - see 1.2.2.1.
- c. Measurements during test - Relays shall be monitored for closing of open contacts or opening of closed contacts in excess of 10 microseconds in accordance with method 310, test circuit A, of MIL-STD-202.
- d. Electrical operating conditions - For each direction of shock, the heater shall be unenergized during two shocks and energized during one shock with rated heater voltage for 15 times normal operate time plus 5 minutes before test.
- e. Measurements after shock - As specified in 3.12.

4.7.9.2 Method II. Relays shall be tested in accordance with method 207 of MIL-STD-202. The following details and exceptions shall apply:

- a. Mounting - Normal mounting means.
- b. Test condition - See table I of 1.2.2.1.
- c. Measurements after test - As specified in 3.12.

4.7.10 Centrifugal acceleration (when applicable) (see 3.13). Relays shall be tested in accordance with 4.7.10.1 or 4.7.10.2, as specified (see 3.1 and 6.2.1).

4.7.10.1 Acceleration test 1.

- a. Relays shall be mounted on the test centrifuge by normal mounting means.
- b. Relays shall be subjected to constant acceleration of the value specified (see 3.1) in both directions along each of three mutually perpendicular axes, one of which shall be parallel to the direction of contact motion.
- c. The acceleration shall be increased from zero to the specified value in approximately 2 minutes and held at the maximum for 2 minutes in both the unenergized and the energized conditions.
- d. A neon light or other suitable indicator shall be connected across the contacts during the entire test to determine the ability of the relay contacts to remain in the proper position.

## MIL-DTL-19648D

- e. Ambient temperature shall be 25°C ±5°C.
- f. During test, in both directions along each of three mutually perpendicular axes, operate time with rated heater input voltage shall be measured. At end of test, normal operate time shall be measured (see 4.7.3.2).

4.7.10.2 Acceleration test 2. Relays shall be tested as specified in 4.7.10.1a thru 4.7.10.1e. In addition, the following shall apply:

- a. Normal heater voltage shall be applied for 15 times rated operate time plus 5 minutes before application of acceleration and during testing. Continuity of each contact shall be continuously monitored. After the test, normal operate time shall be measured as specified in 4.7.3.2.

4.7.11 Overvoltage (see 3.14). Relay heaters shall be energized at room temperature for 8 hours at 110 percent of rated operating voltage. Normal operating time shall be measured before and after test. At end of test, normal operate time tolerance shall be increased by 5 percent.

4.7.12 Vibration (see 3.15). The relays shall be subjected to the applicable test specified in table VIII. At end of test, normal operate time tolerance shall meet the requirements of 3.6.2.1.2.

TABLE VIII. Vibration test.

Level	Test paragraph	Frequency range	Method
1	4.7.12.1	10 - 55 Hz	201 of MIL-STD-202
2	4.7.12.2	10 - 500 Hz	204 of MIL-STD-202, condition A
3	4.7.12.3	10 - 2000 Hz	204 of MIL-STD-202, condition B
4	4.7.12.4	10 - 2000 Hz	204 of MIL-STD-202, condition D

4.7.12.1 Level 1. The following details and exceptions shall apply:

- a. Relays shall be rigidly mounted by their normal mounting means. Plug-in units shall be firmly held in mating socket.
- b. Contacts shall be monitored in accordance with method 310 of MIL-STD-202, test circuit A. The contacts shall be monitored for chatter during the entire test.
- c. Relays shall be energized for the first 60 minutes and unenergized for last 60 minutes.
- d. At the end of the required vibration period in each plane, with the frequency at maximum of range, energize the relay at rated heater input and measure operate time to first evidence of chatter and duration of chatter. The time to the first sign of chatter shall be not less than 80 percent of the normal operate time, and the chatter duration not more than 25 percent of the normal operate time.
- e. At the conclusion of the test, insulation resistance, dielectric withstanding voltage at sea level, contact resistance and normal operate time shall be measured as specified in 4.7.6, 4.7.5.1, 4.7.3.1, and 4.7.3.2, respectively.

4.7.12.2 Level 2. Relays shall be tested in accordance with details specified in table VIII and 4.7.12.1, except that test condition A of method 204 shall be used. During the first three cycles of the frequency band in each direction, a light dc load (0.01 ampere maximum and 6 volts maximum) shall be applied to the contacts and 90 percent of the actual minimum hold-in voltage shall be applied to the heater. The



## MIL-DTL-19648D

relays shall be carefully observed for evidence of resonance during this portion of test. If no resonance is detected, the next three cycles shall be run with the relay stabilized at rated voltage and the last three cycles unenergized. If resonance is found, the frequency shall be adjusted to the maximum resonance and the relay vibrated for the period of time normally required for the next three cycles energized, three cycles unenergized. Then, with vibration at maximum point of resonance, energize the relay at rated heater input and measure operate time to first sign of chatter and duration of chatter. The time to the first sign of chatter shall be not less than 80 percent of the operate time, and the chatter duration not more than 25 percent of the operate time. The frequency band (or bands) over which resonance occurs shall be recorded.

4.7.12.3 Level 3. Details shall be as specified in 4.7.12.2 except test condition B shall apply.

4.7.12.4 Level 4. Details shall be as specified in 4.7.12.2 except test condition D shall apply.

4.7.13 Moisture resistance (see 3.16). Relays shall be tested in accordance with method 106 of MIL-STD-202. The following details and exceptions shall apply:

- a. Initial measurement - Insulation resistance shall be measured at room ambient temperature at the end of the initial drying period (see 4.7.6).
- b. Polarization - During steps 1 to 6 inclusive, a polarizing voltage of 100 volts dc shall be applied between all terminals tied together and the metal mounting (noncorrosive) panel. The negative polarity shall be applied to the metal panel. Steps 7a and 7b are not applicable.
- c. Loading voltage - Not applicable.
- d. Final measurements - Insulation resistance shall be measured for first article tests after 1 hour of drying at room temperature at the end of last cycle and dielectric withstanding voltage, normal operate time, contact resistance, and corona. Insulation resistance shall be measured for quality conformance inspection tests.

4.7.14 Overload (see 3.17). Unless otherwise specified (see 3.1), the relay contacts shall make and break at rated voltage, the current specified in 4.7.14.1, 4.7.14.2, or 4.7.14.3, as applicable, for 50 operations each. At the end of the test, contact resistance and normal operate time shall be measured as specified in 4.7.3.1 and 4.7.3.2, respectively.

4.7.14.1 Resistive. When the load is specified as resistive ac (see 3.1 and 6.2.1), contacts shall make and break twice the rated current. When the load is specified as resistive dc (see 3.1 and 6.2.1), contacts shall make and break 1.25 times the rated current load. Switching rate and ratio of "on" to "off" time shall be as specified for the life test in 4.7.16.

4.7.14.2 Inductive. When the load is specified as inductive ac (see 3.1 and 6.2.1), contacts shall make and break two rated inductive load circuits connected in parallel across the power source. When the load is specified as inductive ac (see 3.1 and 6.2.1), the inductive load component shall be the same as used in the life test (see 4.7.16) and the series resistance shall be reduced to 80 percent of the value used in the life test. Switching rate and ratio of "on" to "off" time shall be as specified for the life test in 4.7.16.

4.7.14.2.1 Inductive load component. For contacts rated inductively up to and including 1.0 ampere dc, a load component of 200 millihenries minimum inductance shall be used. For contacts rated inductively greater than 1.0 ampere dc up to and including 5.0 amperes dc, a load component of 50 millihenries minimum inductance shall be used. For contacts rated inductively greater than 5.0 amperes dc up to and including 10.0 amperes dc, a load component of 20 millihenries inductance shall be used. The inductance

## MIL-DTL-19648D

shall be measured on a 60-cycle inductance bridge with approximately 5 volts rms applied to the inductive load component. The inductance shall be measured with maximum rated dc current flowing through the inductive load component. The inductive load component shall be air gapped to give substantially constant inductance over the application range of current. Inductive ac load circuits shall use a suitable combination of resistive and inductive load to insure that the power factor will be 50 percent at the frequency used. For all dc induction loads from 2 to 100 amperes, approval by the qualifying activity is required (see 6.8).

4.7.14.3 Tungsten lamp. When the load is specified as tungsten lamp (see 3.1 and 6.2.1), contacts shall make and break twice the rated load, which shall be composed entirely of tungsten lamps operated at their rated voltage. Switching rate and ratio of "on" to "off" time shall be as specified for the life test in 4.7.16.

4.7.15 Salt spray (corrosion) (see 3.18). Relays shall be tested in accordance with method 101 of MIL-STD-202. The following details shall apply:

- a. Test condition letter - B.
- b. Measurements after exposure - Not applicable.

After test, relays shall be examined for evidence of corrosion; peeling, chipping, and blistering of the finish; and exposure of base metal.

4.7.16 Life (see 3.19).

4.7.16.1 Life test with specified off time (for mechanical and contact life test). All contacts of each relay shall be subjected to cycling with nominal coil voltage and rated contact load and voltage (see 3.1 and 6.2.1). The cycling rate shall be determined as follows:

Off time = 6 x normal operate time (N.O.T.) or 300 seconds, whichever is greater.

On time = N.O.T. plus 2 x N.O.T. tolerance.

Following is a listing of operate time ratings and applicable life test cycles:

<u>N.O.T. rating (seconds)</u>	<u>Cycles of operation</u>
Up to 60	5,000
Above 60 to 80	4,000
Above 80 to 120	2,200
Above 120 to 160	1,600
Above 160 to 180	1,500
Above 180 to 300	1,000

The relay operation cycling shall be such that the heater voltage shall be removed immediately after the relay contacts operate (open or close) as applicable. Every operation cycle of the contacts shall be monitored for failure to close (normally open relay) or failure to open (normally closed relay), as applicable. A failure to open or a failure to close for each cycle shall be considered a "miss." The test equipment used for continuous monitoring of the contacts shall have an automatic cutoff when a "miss" occurs or it shall record the number and time of occurrence of each "miss." The test equipment shall also count and record the number of cycles the relay is energized. The first 50 percent of the test cycles shall be performed at the maximum ambient temperature rating of the applicable temperature class (see 1.2.2.2

## MIL-DTL-19648D

and 3.1). A periodic test of normal operate time after each 20 percent of the life test shall be conducted after stabilizing the relay at room temperature of  $25^{\circ}\text{C} \pm 5^{\circ}\text{C}$  for at least 1 hour, and the test results recorded. The remaining 50 percent of the life test shall be conducted at room temperature ambient of  $25^{\circ}\text{C} \pm 5^{\circ}\text{C}$ . During and at the end of test specified in 4.7.16.1, the relay shall meet N.O.T. tolerance requirements of 3.6.2.1.2.

4.7.16.2 Life test with heater power recycled immediately after contact operation (for accelerated contact life test). The relay contacts shall be loaded with rated resistive current and voltage. Heater voltage shall be rated voltage. The additional contact life cycles and applicable normal operate time range are:

<u>N.O.T. rating (seconds)</u>	<u>Additional cycles</u>	<u>Total life test cycles</u>
Up to 60	20,000	25,000
Above 60 to 80	11,000	15,000
Above 80 to 120	8,800	11,000
Above 120 to 160	4,800	6,400
Above 160 to 180	4,000	5,500
Above 180 to 300	3,000	4,000

For the first cycle, the relay shall be operated for normal operate time (N.O.T.) plus N.O.T. tolerance. Successive heater energizing time(s) shall be decreased until the cycling time is as short as practicable consistent with the contacts completely making and breaking, or breaking and making the load (as applicable) for each operation. At the end of the additional cycling test, the relay shall be subjected to  $25^{\circ}\text{C}$  ambient temperature for at least 1 hour. Normal operate time shall be measured at the end of the 1-hour period followed by contact resistance, insulation resistance, and dielectric withstanding voltage as specified in 4.7.3.2, 4.7.3.1, 4.7.6, and 4.7.5, respectively.

4.7.16.3 Heater life test. Before heater life test, conduct normal operate time test (see 4.7.3.2) on three relays following which the three relays shall be placed in an ambient temperature of maximum rated (see 3.1) with the heater energized with nominal voltage for a period of 200 hours. At the end of this period with the relay at  $25^{\circ}\text{C}$ , normal operate time test (see 4.7.3.2) shall be conducted. The relays shall then be subjected to  $25^{\circ}\text{C} \pm 5^{\circ}\text{C}$  ambient temperature and the heater energized with nominal voltage for an additional 200 hours. At the end of the second 200-hour period, the relay shall be allowed to stabilize at  $25^{\circ}\text{C}$  and normal operate time shall be tested as specified in 4.7.3.2.

4.7.16.4 Load impedance. A load impedance shall be connected to each NO and NC contact, and the power supply shall be connected to each movable, or "common" contact. If the life test load is resistive, suitable resistors shall be used as load resistance. If the life test load is specified as tungsten lamp, resistance components shall be composed entirely of tungsten lamps, which shall be operated at their rated voltage. Specified current shall flow when the lamps have stabilized. If the life test is specified as inductive, an appropriate inductive load component shall be used. A suitable resistor load may be placed in series with the inductive load component to obtain rated steady state current flow. If the contact rating includes two or more loads, a minimum of two sample units shall be loaded with each load. For all dc inductive loads from 2 amperes to 100 amperes, approval of the inductors by the qualifying activity is required (see 6.8).

## MIL-DTL-19648D

4.7.16.5 Power supply characteristics. If the rated contact load is dc, the ripple (cause by commutator, rectifier or battery charger) shall not exceed 5 percent under maximum load measured at the load terminals; the no-load and full-load voltage shall not differ more than 5 percent measured at the relay contacts connected to the source; and the source impedance shall be essentially noninductive. For ac contact loads, the source impedance shall not exceed 2 percent of the load impedance.

## 5. PACKAGING

5.1 Packaging. For acquisition purposes, the packaging requirements shall be as specified in the contract or order (see 6.2). When actual packaging of materiel is to be performed by DoD personnel, these personnel need to contact the responsible packaging activity to ascertain requisite packaging requirements. Packaging requirements are maintained by the Inventory Control Point's packaging activity within the Military Department or Defense Agency, or within the Military Department's System Command. Packaging data retrieval is available from the managing Military Department's or Defense Agency's automated packaging files, CD-ROM products, or by contacting the responsible packaging activity.

## 6. NOTES

(This section contains information of a general or explanatory nature that may be helpful, but is not mandatory.)

6.1 Intended use. Relays conforming to this specification are intended for use in electronic and communication equipment. Their principal areas of application are for ground-support electronic and communication equipment. Relays covered by this specification operate satisfactorily in systems under the following demanding conditions: operating temperature range of -65°C to +125°C, 20 g's to 100 g's of vibration, 50 g's to 1500 g's of shock, and have reduced susceptibility to corrosion in salt water environments. This does not preclude the use of these relays in other military applications.

6.2 Acquisition requirements. Acquisition documents must specify the following:

- a. Title, number, and date of the specification.
- b. Issue of DoDISS to be cited in the solicitation, and if required, the specific issue of individual documents referenced (see 2.2).
- c. Packaging requirements (see 5.1).

6.2.1 Items not covered by specification sheets. For relays not covered by specification sheets, the procurement document should specify the following:

- a. Title, number, and date of this specification.
- b. Title, number, and individual services or manufacturers drawing.
- c. Shock level, temperature class, and vibration level (see 1.2.2).
- d. Rated heater voltage (see 3.4.1.1).
- e. Contact arrangement and contact rating (see 3.4.2).
- f. Terminal design (see 3.4.3).

## MIL-DTL-19648D

- g. Weight of relay (see 3.4.5).
- h. Normal operate time (see 3.6.2).
- i. Applicable seal test (see 3.7).
- j. Applicable acceleration test, if required (see 3.13).
- k. Dielectric withstanding voltage (see 3.8).
  - (1) Test condition letter, if other than D (see 4.7.5.2b).
- l. Applicable shock test (see 3.12).
- m. Number of sample units (see 4.5).
- n. Levels of preservation and packing required (see 5.1 and 5.2).
- o. If special or additional identification marking is required (see 5.3).

6.3 First article inspection. Information pertaining to first article inspection of products covered by this specification should be obtained from the procuring activity for the specific contracts involved (see 3.2).

6.4 Subject (key word) listing.

Temperature class  
Vibration level

6.5 PIN. This specification requires a PIN that describes codification and/or classification and appropriate references to associated documents (see 1.2.1 and 3.1).

6.6 Definitions. For the purpose of this specification, the following definitions apply:

6.6.1 Rated heater voltage (see 3.4.1.1). Rated heater voltage is that voltage at which the relay is designed to operate; that is, the voltage required in the heater element to cause the relay to perform its operation in the time delay specified in the specification sheet.

6.6.2 Normal operate time (see 3.6.2). Normal operate time is the time interval between applying power at nominal voltage to the energizing heater, starting with all elements of the relay substantially at ambient temperature, and electrically closing normally open (NO) contacts (including contact bounce time) or electrically opening normally closed (NC) contacts.

6.6.3 Normal operate time tolerance (see 3.6.2.1). Normal operate time tolerance is the tolerance applied when the operating time is measured to nominal voltage with the relays stabilized at room ambient.

6.6.4 Minimum operate voltage (see 3.6.3). Minimum operate voltage is the minimum value of voltage at which the relay will operate in not more than four times normal operate time, and remain operated.

6.6.5 Minimum hold-in voltage (see 3.6.3). Minimum hold-in voltage is the minimum value to which the heater voltage can be reduced after saturation at rated voltage, for which the contacts will always maintain their energized positions.

## MIL-DTL-19648D

6.6.6 Nonstandard relays (see 4.5). Nonstandard relays are relays not covered by specification sheets.

6.6.7 Instant release time (see 4.7.3.4.1). Instant release time is the time interval, after cutting off power to the energizing heater at the instant of the end of operate time, until normally open contacts reopen or normally closed contacts reclose and all contact bounce has ceased.

6.6.8 Saturate release time (see 4.7.3.4.2). Saturate release time is the time interval, after cutting off power to the energizing heater at saturation at rated heater voltage until normally open contacts reopen or normally closed contacts reclose and all contact bounce has ceased.

6.6.9 Instant recovery time (see 4.7.3.5.1). Instant recovery time is the time interval required for cooling, after cutting off power to the energizing heater at the instant of the end of operate time, to regain 85 percent of the normal operate time at the next cycle of operation.

6.6.10 Saturate recovery time (see 4.7.3.5.2). Saturate recovery time is the time interval required for cooling, after cutting off power to the energizing heater after saturation at rated voltage, to regain 85 percent of the normal operate time on the next cycle of operation.

6.6.11 Saturate time. Saturate time is the time interval after power is applied to the energizing heater, starting with all elements of the relay substantially at ambient temperature, until all elements have reached a substantially stable temperature.

6.7 Cross reference of part numbers. For the substitutability relationship of items covered by this specification and items covered by superseded documents, see 3.1.

6.8 Inductors. Inductors meeting the requirements of MIL-I-81023, "Inductor, 28 V.D.C. Laboratory Test, General Specification For" have been considered acceptable.

6.9 Changes from previous issue. Marginal notations are not used in this revision to identify changes with respect to the previous issue due to the extensiveness of the changes.

Custodians  
 Army - CR  
 Navy - EC  
 Air Force - 11  
 DLA - CC

Preparing activity  
 DLA - CC  
  
 (Project 5945-1134)

Review activities:  
 Army - AR, AT, AV  
 Navy - AS, MC, OS, SH  
 Air Force - 19

## STANDARDIZATION DOCUMENT IMPROVEMENT PROPOSAL

### INSTRUCTIONS

1. The preparing activity must complete blocks 1, 2, 3, and 8. In block 1, both the document number and revision letter should be given.
2. The submitter of this form must complete blocks 4, 5, 6, and 7, and send to preparing activity.
3. The preparing activity must provide a reply within 30 days from receipt of the form.

NOTE: This form may not be used to request copies of documents, nor to request waivers, or clarification of requirements on current contracts. Comments submitted on this form do not constitute or imply authorization to waive any portion of the referenced document(s) or to amend contractual requirements.

<b>I RECOMMEND A CHANGE:</b>	<b>1. DOCUMENT NUMBER</b> MIL-DTL-19648D	<b>2. DOCUMENT DATE (YYMMDD)</b> 020215
<b>3. DOCUMENT TITLE</b> Relays, Time Delay, Thermal, General Specification for		
<b>4. NATURE OF CHANGE</b> (Identify paragraph number and include proposed rewrite, if possible. Attach extra sheets as needed.)		
<b>5. REASON FOR RECOMMENDATION</b>		
<b>6. SUBMITTER</b>		
a. NAME (Last, First, Middle initial)	b. ORGANIZATION	
c. ADDRESS (Include Zip Code)	d. TELEPHONE (Incl. Area Code) (1) Commercial (2) DSN (If applicable)	7. DATE SUBMITTED (YYYYMMDD)
<b>8. PREPARING ACTIVITY</b>		
a. NAME Defense Supply Center, Columbus ATTN: VAT	b. TELEPHONE (Include Area Code) (1) Commercial (2) DSN (614) 692-0542 850-0542	
c. ADDRESS (Include Zip Code)  Post Office Box 3990 Columbus, OH 43216-5000	<b>IF YOU DO NOT RECEIVE A REPLY WITHIN 45 DAYS, CONTACT:</b> Defense Standardization Program Office (J-330) 8725 John J. Kingman Road, Suite 4235 Fort Belvoir, Virginia 22060-6221 Telephone (703) 767-6888 DSN 427-6888	