

INCH-POUND

MIL-DTL-14055G  
1 May 2014  
SUPERSEDING  
MIL-DTL-14055F  
17 August 2011

## DETAIL SPECIFICATION

### CUP, HYDRAULIC BRAKE ACTUATING CYLINDER: SYNTHETIC RUBBER

Inactive for new design after 22 January 1999.

This specification is approved for use by all Departments and Agencies of the Department of Defense.

#### 1. SCOPE

1.1 Scope. This specification covers molded cups, 2 inches in diameter and under, compounded from high temperature resistant rubber for use in hydraulic actuating cylinders employing hydraulic brake fluid of non-mineral oil type.

#### 2. APPLICABLE DOCUMENTS

2.1 General. The documents listed in this section are specified in sections 3 and 4 of this specification. This section does not include documents cited in other sections of this specification or recommended for additional information or as examples. While every effort has been made to ensure the completeness of this list, document users are cautioned that they must meet all specified requirements of documents cited in sections 3, and 4 of this specification, whether or not they are listed.

#### 2.2 Government documents.

2.2.1 Specifications, standards, and handbooks. The following specifications, standards, and handbooks form a part of this document to the extent specified herein. Unless otherwise specified, the issues of these documents are those cited in the solicitation or contract.

#### FEDERAL STANDARD

FED-STD-791 - Lubricants, Liquid Fuels, and related Products; Methods of Testing

#### DEPARTMENT OF DEFENSE SPECIFICATIONS

MIL-PRF-46176- Brake Fluid, Silicone, Automotive, All Weather, Operational and Preservative

Comments, suggestions, or questions on this document should be addressed to: DLA Land and Maritime, Attn: VAI, P.O. Box 3990, Columbus, OH 43218-3990, or emailed to [FluidFlow@dla.mil](mailto:FluidFlow@dla.mil). Since contact information can change, you may want to verify the currency of this address information using the ASSIST Online database at <https://assist.dla.mil>.

MIL-DTL-14055G

(Copies of these documents are available online at <http://quicksearch.dla.mil>.)

2.3 Non-Government publications. The following documents form a part of this document to the extent specified herein. Unless otherwise specified, the issues of these documents are those cited in the solicitation or contract.

ASTM INTERNATIONAL

- ASTM A1008/A1008M - Steel, Sheet, Cold-Rolled, Carbon, Structural, High-Strength Low-Alloy, High-Strength Low-Alloy with Improved Formability, Solution Hardened, and Bake Hardenable
- ASTM A624/A624M - Tin Mill Products, Electrolytic Tin Plate, Single Reduced
- ASTM B36/B36M - Brass Plate, Sheet, Strip and Rolled Bar
- ASTM B152/B152M - Copper, Sheet, Strip, Plate, and Rolled Bar
- ASTM B209 - Aluminum and Aluminum-Alloy Sheet and Plate (METRIC)
- ASTM D91 - Oils, Lubricating, Precipitation Number of
- ASTM D573 - Rubber-Deterioration in an Oven
- ASTM D2240 - Rubber Property-Durometer Hardness

(Copies of these documents are available online at <http://www.astm.org>.)

INTERNATIONAL ORGANIZATION FOR STANDARDIZATION (ISO)

- ISO 17025 General requirements for the competence of testing and calibration laboratories

(Copies of these documents are available online at <http://www.iso.ch>.)

NCSL INTERNATIONAL

- NCSL Z540.3 Requirements for the Calibration of Measuring and Test Equipment

(Copies of these documents are available online at <http://www.ncsli.org>.)

SAE INTERNATIONAL

- SAE J431 - Automotive Gray Iron Castings
- SAE J527 - Brazed Double Wall Low Carbon Steel Tubing

(Copies of these documents are available online at [www.sae.org](http://www.sae.org).)

2.4 Order of precedence. Unless otherwise noted herein or in the contract, in the event of a conflict between the text of this document and the references cited herein, the text of this document takes precedence. Nothing in this document, however, supersedes applicable laws and regulations unless a specific exemption has been obtained.

## MIL-DTL-14055G

## 3. REQUIREMENTS

3.1 Qualification. Cylinder cups furnished under this specification shall be products that are authorized by the qualifying activity for listing on the applicable Qualified Products List (QPL) before contract award (see 4.4 and 6.3).

3.2 Used, rebuilt or remanufactured components. No used, rebuilt or remanufactured components, pieces, or parts, shall be used on the cylinder cups.

3.3 Materials. The materials used in the cylinder cups shall be a compound using a copolymer product of butadiene and styrene (SBR) or ethylene propylene rubber (EPDM) as the basic material. The quality of the ingredients used in an approved compound shall be so controlled as to insure uniformity of performance of the cylinder cups.

3.3.1 Reference critical interface, materials, and processes. The materials and processes identified in this specification are intended to assure mechanical compatibility, eliminate problems of contamination of critical hydraulic fluids and hydraulic brake systems. Manufacturers of wheel cylinder cups, master cylinder primary cups, and master cylinder secondary cups supplied to this specification may use alternate industry recognized standards for materials and processes, provided prior approval is granted by the qualifying activity. The use of such alternatives shall not result in inferior short term or long-term performance or reliability.

3.3.2 Recycled, recovered environmentally preferable, or biobased materials. Recycled, recovered, environmentally preferable, or biobased materials should be used to the maximum extent possible, provided that the material meets or exceeds the operational and maintenance requirements, and promotes economically advantageous life cycle costs.

3.4 Physical Properties.3.4.1 Durometer hardness (Shore A).

3.4.1.1 Durometer hardness for qualification. When tested as specified in 4.7.2 for qualification, the durometer hardness of the cups shall be within the limits of 55 to 75 points.

3.4.1.2 Durometer hardness for conformance. When tested as specified in 4.7.2 for conformance, the durometer hardness of the cups shall be equal to the qualified value  $\pm 5$  points, providing it is within the limits of 55 to 75 points. The qualified value is the durometer hardness value obtained on a particular size and compound of cup at the time of qualification testing. The same value is thereby established for the other sizes of cups of that same compound for which qualification has been established.

3.4.2 Accelerated aging. After cylinder cups have been subjected to the accelerated aging test specified in 4.7.3, the change in durometer hardness (see 3.4.1) shall be within the limits of -5 to +5 points.

3.4.3 Low temperature.

3.4.3.1 Bendability. When subjected to the bend test specified in 4.7.4.1, the cup shall not crack and shall return to its approximate original shape within 1 minute.

3.4.3.2 Fluid leakage. When cups are tested as specified in 4.7.4.2, there shall be no leakage of fluid during the test.

3.4.4 Resistance to fluids at elevated temperature. After cylinder cups have been tested as specified in 4.7.5, changes in physical properties shall be within the limits shown in table I.

## MIL-DTL-14055G

TABLE I. Change in physical properties.

Physical properties	Change
Volume	+5 to +20 percent
Outside diameter (lip)	0 to +5.75 percent
Outside diameter (base)	0 to +5.75 percent
Durometer hardness	0 to -15 points

3.4.5 Heat-pressure stroking. When tested as specified in 4.7.6, the cylinder cups shall conform to the following requirements.

3.4.5.1 Volume loss. The volume loss of brake fluid due to leakage past the secondary cup of the master cylinder or past the wheel cylinder cups during any 24,000-stroke period in the test, shall not exceed 3.5 milliliters or 10 milliliters for the 70,000-stroke period. (see 4.7.6.3)

3.4.5.2 Pressure change. The pressure in the simulated brake system shall not vary more than  $\pm 50$  psi (3.45 bars) from the initial stroking pressure throughout the 70 - hour test period. (see 4.7.6.3)

3.4.5.3 Leakage. After the 24-hour cooling period specified in the test, the following shall be cause for rejection (see 4.7.6.3):

1. Constant dampness past the cups on two or more inspections due to leakage.
2. Fluid discoloration of the filter paper on two or more inspections due to leakage.

3.4.5.4 Lip diameter interference. After test, the minimum lip diameter of the cups shall be greater than the cylinder bore by the minimum dimensions shown in table II. This dimensional quality of a cup is known as its lip diameter interference. (see 4.7.6.3)

TABLE II. Lip diameter interference. 1/ 2/

Cup Size (diameter)	Wheel Cylinder Cup	Master and Slave Cylinder Cup
To 1 in. (2.54cm)	0.030 in. min. (0.0762cm)	0.020 in. min. (0.0508cm)
1 to 1.5 in. (2.54 to 3.81cm)	0.035 in. min. (0.0889cm)	0.025 in. min. (0.0635cm)
1.5 to 2 in. (3.81 to 5.08cm)	0.040 in. min. (0.1016cm)	0.030 in. min. (0.0762cm)

1/ Dimensions are in inches.

2/ Metric equivalents are given for information only.

3.4.5.5 Appearance of rubber cups. At the completion of the test, the cylinder cups shall show no more than a moderate amount of shipping, scuffing, blistering, cracking, tackiness, or change in shape from original appearance. (see 4.7.6.3)

3.4.5.6 Hardness. Rubber cups shall not decrease in hardness by more than 15 points. (see 4.7.6.3)

3.4.5.7 Corrosion. Pistons and cylinder bore shall not show corrosion as evidenced by pitting to an extent discernible to the naked eye. (see 4.7.6.3)

3.4.5.8 Sedimentation. Not more than 1.5 percent sediment by volume shall be in the centrifuge tube after the fluid from the stroking test has been tested as specified in 4.7.6.3. The sedimentation shall show no crystalline particles. (see 4.7.6.3)

3.4.6 Corrosiveness. When the cylinder cups have been tested for corrosiveness as specified in 4.7.7, the test results shall be as follows.

3.4.6.1 Metal strips. The metal strips shall not be pitted nor etched. (see 4.7.7.3) The permissible loss in weight of the strips shall be as specified in table III.

## MIL-DTL-14055G

TABLE III. Loss in weight.

Metal	Loss in Weight mg/sq cm, Max.
Tinned iron	0.2
Steel	0.2
Aluminum alloy	0.1
Cast iron	0.2
Brass	0.4
Copper	0.4

3.4.6.2 Disintegration of rubber cup. The rubber cup exposed to the brake fluid-water mixture shall show no sloughing, tackiness, blisters, nor any other form of disintegration. (Sloughing is indicated by the presence of carbon black on the surface of the rubber cup.) The base diameter of the cup shall not increase more than 0.050 inch (1.3 mm). The hardness of the rubber shall not decrease more than 15 points. (see 4.7.7.3)

3.4.6.3 Fluid. Following the corrosiveness test, the test fluid shall show no jelling or crystalline deposit, and shall contain not more than 0.05 percent (by volume) precipitated matter. (see 4.7.7.3)

3.4.7 Storage corrosion. When cylinder cups are tested as specified in 4.7.8 there shall be no evidence of corrosion adhering to or penetrating the wall of the test cylinder bore which was in contact with the test cup. Slight discoloration (staining) or corrosion away from the contact surface of the test cups shall not be cause for rejection.

3.5 Identification. The part or identification number (PIN) shall be marked on the package and shall include the PIN, the manufacturer's name or CAGE code, and date code. The identification mark of the manufacturer and other marking as specified on applicable drawings (see 6.2) shall be molded into each cylinder cup.

3.6 Workmanship. Wheel cylinder cups, master cylinder primary cups, and master cylinder secondary cups shall be processed in such a manner as to be uniform in quality and shall be free from burrs, crazing, cracks, voids, pimples, chips, blisters, pinholes, protuberances, embedded foreign matter and other physical defects that will adversely affect life, serviceability, or appearance.

#### 4. VERIFICATION

4.1 Classification of inspection. The inspection requirements specified herein are classified as follows:

- a. Qualification inspection (see 4.4).
- b. Conformance inspection (see 4.5).

4.2 Test equipment and inspection facilities. Test and measuring equipment and inspection facilities of sufficient accuracy, quality and quantity to permit performance of the required inspection shall be used. The establishment and the maintenance of a calibration system to control the accuracy of all test and measuring equipment shall be in accordance with ISO 17025 and NCSL Z540.3, as applicable.

4.3 Inspection conditions. Unless otherwise specified, all testing shall be conducted at atmospheric pressure within the range of 28 to 31 inches of mercury (71.1 to 78.4 centimeters of mercury), a temperature between 60°F and 100°F (15.6°C to 37.8°C), and a relative humidity of not more than 90%. Tolerances of the test conditions shall be as follows:

- a. Temperature: +10°F, -5°F (+5.55°C, -2.8°C)
- b. Pressure (gauge): ±5%

## MIL-DTL-14055G

4.3.1 Stabilization of test temperatures. Unless otherwise specified, the test temperature in the chamber shall be stabilized before conducting the test.

4.3.2 Test fluids. Unless otherwise specified, the test fluid shall be brake fluid in accordance with MIL-PRF-46176.

4.4 Qualification inspection (see 6.3). Qualification inspection shall be performed at a laboratory acceptable to the qualifying activity on sample units produced with equipment and procedures used in production.

4.4.1 Samples for qualification inspection. Samples for qualification inspection shall be representative of the products proposed to be furnished to this specification.

4.4.2 Inspection routine. The samples shall be subjected to the inspections specified in table IV in the order shown.

TABLE IV. Quality certification inspection.

Requirement	Requirement paragraph	Test method paragraph	Qualification	Conformance (Group A)	Periodic (Group B)
Accelerated aging	3.4.2	4.7.3	X		X
Bendability	3.4.3.1	4.7.4.1	X		
Fluid leak	3.4.3.2	4.7.4.2	X		
Resistance to fluids	3.4.4	4.7.5	X		X
Heat pressure stroking	3.4.5	4.7.6	X		X
Sedimentation	3.4.5.8	4.7.6.3	X		
Corrosiveness	3.4.6	4.7.7	X		
Storage corrosion	3.4.7	4.7.8	X		
Visual	3.4.5.5	4.7.6.3	X	X	
Hardness	3.4.1.1	4.7.2	X	X	

4.4.3 Failures. One or more failures shall be cause for refusal to grant qualification approval.

4.4.4 Retention of qualification. To retain qualification, the supplier shall submit a report at 12-month intervals to the qualifying activity. The qualifying activity shall establish the initial reporting date. Each report shall contain a summary of the results obtained from both the sampling tests and the periodic control tests performed during the 12-month interval. The number of lots and quantities of molded cups that have passed and failed shall be included. All reworked sampling lots shall be accounted for and identified.

4.4.4.1 Nonconformance of qualification. If the summary of test results indicates nonconformance with the requirements specified herein and the corrective measures acceptable to the qualifying activity has not been taken, action may be taken to remove the failing product from the QPL.

4.4.4.2 Periodic qualification test report. Failure to submit the report within 30 days after the end of each 12-month period may result in loss of qualification. In addition to the periodic submission of inspection data, the manufacturer shall immediately notify the qualifying activity at any time during the 12-month period that the inspection data indicates failure of the qualified product to meet the requirements specified herein. If there has been no production during the reporting period, a report shall be submitted certifying that the manufacturer still has the capabilities and the facilities necessary to produce the qualified product. If there has been no production during two consecutive report periods, the manufacturer may be required, at the discretion of the qualifying activity, to submit his qualified product for testing in accordance with the qualification inspection requirements.

## MIL-DTL-14055G

4.5 Conformance inspection.

4.5.1 Inspection of product for delivery. Inspection of product for delivery shall consist of individual inspections in [table V](#).

TABLE V. Individual inspection.

Inspection	Requirement paragraph	Test paragraph
Visual, mechanical, inspection	<a href="#">3.4.5.5</a>	<a href="#">4.7.6.3</a>
Durometer Hardness	<a href="#">3.4.1.2</a>	<a href="#">4.7.2</a>

4.5.2 Sampling for individual inspections. Molded cups for sampling shall be selected from a production lot ([see 4.5.2.1](#)) and shall be subjected to the individual inspections. The sampling size shall be as specified in [4.5.2.2](#).

4.5.2.1 Production lot. A production lot shall consist of all molded cups of the same Part or Identifying Number (PIN) which have been manufactured under the same conditions and on the same continuous run.

4.5.2.2 Inspection sample. The inspection sample shall be product selected at random from the production lot without regard to quality and shall be the size specified in [table VI](#).

TABLE VI. Lot and sample size.

Lot size	Sample size
2 to 5	100 percent
16 to 150	5
151 to 1,200	20
1,201 to 10,000	32
10,001 to 35,000	50
35,001 to 500,000	80
500,001 and over	125

4.5.2.3 Nonconformance of sampling tests. If one or more defects are identified, then the entire production lot shall be screened for that defect and all defects shall be removed. A second inspection sample shall then be selected and the sampling tests shall be performed again. If one or more defects are identified from the second inspection lot, then the entire production lot shall be rejected and not supplied to this specification.

4.5.3. Periodic tests. Periodic tests as specified in [table VII](#) shall be performed on five molded cups for each size at least once per year regardless of the total number of molded cups produced, [see 4.5.3.1](#). The five molded cups selected shall be as representative as possible of those produced during the period in terms of molded cup material and joint configuration. If there has been no production for a particular size, during the past year, the periodic test is not required for that size.

TABLE VII. Periodic inspection.

Inspection	Requirement paragraph	Test paragraph
Accelerated aging	<a href="#">3.4.2</a>	<a href="#">4.7.3</a>
Low temperature	<a href="#">3.4.3</a>	<a href="#">4.7.4</a>
Resistance to fluids	<a href="#">3.4.4</a>	<a href="#">4.7.5</a>
Heat pressure stroking	<a href="#">3.4.5</a>	<a href="#">4.7.6</a>

## MIL-DTL-14055G

4.5.3.1 Reduced test frequencies periodic tests. If there have been no reported failures after two consecutive intervals, then periodic testing, with the written approval of the Qualifying Activity, may be performed at 24 month intervals. If there are no reported failures after the next 24 month interval, then periodic testing, with the written approval of the Qualifying Activity, can be done at 36 month intervals. If the design, material, construction, or processing of the part are changed, or if there are any quality problems or failures, the Qualifying Activity may require resumption of the original test frequency.

#### 4.6 Manufacturing production.

4.6.1 Change to manufacturing process, materials or equipment. The manufacturer shall notify the qualifying activity, in writing, of any changes in the manufacturing process, materials, or equipment used to manufacture a qualified product list (QPL) product. Subsequently, the qualifying activity shall notify the manufacturer, in writing, if a full re-qualification, partial re-qualification, or no additional testing is required as a result of these changes.

4.6.2 No production during reporting period (12 months). When no production occurs during the reporting period, a report shall be submitted to the qualifying activity certifying that the manufacturer still has the capability and facilities necessary to produce the QPL product.

#### 4.7 Methods of inspection.

4.7.1 Test methods. The following tests and test methods assure wheel cylinder cups, master cylinder primary cups, and master cylinder secondary cups integrity within typical operating conditions and applications. Alternate test methods are allowed with prior approval by the qualifying activity. The test methods described herein are the preferred methods and take precedence when alternate test methods give differing or conflicting results.

4.7.2 Durometer hardness. To determine conformance to 3.4.1, the durometer hardness shall be determined in accordance with ASTM D2240 or Method 361 of FED-STD-791, and using a type A Shore durometer. The same operator shall make all hardness determinations for any one test.

4.7.2.1 Apparatus. The apparatus shall incorporate the use of a rubber anvil having a durometer hardness in the same range as the cup being tested and of such shape as to mate with the inner contour of the cup, and metal fixture to hold the anvil firmly and provide a level seat for the instrument.

4.7.3 Accelerated aging. The cups shall be subjected to the accelerated aging test specified in ASTM D573 with the following exceptions:

- a. Two cups shall be rinsed in isopropyl alcohol or ethyl alcohol and wiped dry with a lint-free cloth to remove dirt and packing debris. The cups shall not remain in the alcohol for more than 30 seconds.
- b. The cups shall be tested for durometer hardness as specified in 4.7.2.
- c. The cups shall be aged at a temperature of  $212^{\circ}\text{F} \pm 2^{\circ}\text{F}$  ( $100^{\circ}\text{C} \pm 1.5^{\circ}\text{C}$ ) for 70 hours.
- d. At the end of the 70-hour period, the cups shall be removed from the oven, placed on a table with a wooden top and allowed to cool for 30 minutes to room temperature. The cups shall then be retested for durometer hardness to determine their conformance to 3.4.2.

#### 4.7.4 Low temperature test.

4.7.4.1 Bendability. Cups when subjected to bendability testing shall meet the requirements in 3.4.3.1. The following details and conditions shall apply:

- a. One cylinder cup shall be used as a test specimen.
- b. The specimen shall be rinsed in isopropyl alcohol or ethyl alcohol, and wiped dry with a lint-free cloth.
- c. The cylinder cup shall not remain in the alcohol for more than 30 seconds.



## MIL-DTL-14055G

- d. The test cup shall be subjected to -40°F to -45.4°F (-40°C to -43°C) for 22 hours.
- e. The cup shall be bent through an angle of approximately 90 degrees and immediately released. The cold cup shall be handled in a manner to prevent warming.
- f. Within a minute examine test cup for cracking and change in shape from original appearance to determine conformance to [3.4.3.1](#).

4.7.4.2 Leakage. Cups when subjected to leakage testing shall meet the requirements in [3.4.3.2](#). The following details and conditions shall apply:

- a. The test setup shall include the following:
  1. A cold chamber large enough to permit arrangement of the apparatus within, for checking and operation without removal from the chamber.
  2. A master cylinder and four wheel cylinders so connected that their operation closely approximates the brake system in actual service.
  3. A pressure gage.
- b. The test setup shall conform to the following:
  1. The brake cylinder containing the specimens under test shall meet the dimensional limitations of a new cylinder.
  2. The retractor spring shall be such as to require not more than 50 psi (3.45 bar) line pressure to make a complete stroke at room temperature.
- c. The specimens for test shall consist of one primary and one secondary master cylinder cup and eight wheel cylinder cups.
  1. The specimens shall be rinsed in isopropyl alcohol or ethyl alcohol and wiped dry with a lint-free cloth.
  2. The specimens shall not remain in the alcohol for more than 30 seconds.
  3. The specimens shall be assembled in the test cylinders.
  4. During assembly of the cylinder assembly, the cylinder walls shall be coated with and each other part shall be dipped in brake fluid conforming to MIL-PRF-46176.
  5. The cylinder assembly shall be assembled with the master cylinder in the test apparatus in the cold chamber.
  6. The system shall be filled with brake fluid conforming to MIL-PRF-46176 and all air bled from the system. Boots shall not be used.
  7. The assembly shall be subjected to a temperature of -67°F ± 2°F (-55°C ± 1.5°C) for 120 hours.
  8. The pistons and cups shall remain in a static position during the first 72 hours of the test and thereafter shall be actuated 6 strokes at 100 psi (6.89 bar) and 6 strokes at 500 psi (34.47 bar) each 24 hours, that is, after 72, 96, and 120 hours.
  9. The strokes shall be approximately 1 minute apart and the pistons shall return to the stop after each stroke.
  10. The pressure in the system shall be noted and the cylinder examined for leakage during the test, to determine conformance to [3.4.3.2](#).

4.7.5 Resistance to fluids at elevated temperatures. Wheel cylinder cups when subjected to the elevated temperature test shall meet the requirements of [3.4.4](#). The following details and exceptions shall apply.

- a. The apparatus shall include:
  1. A micrometer caliper, shadowgraph, or other device for measuring accurately in thousandths of an inch.
  2. Screwcap glass jars of approximately 1/2-pint (237 ml) capacity with screwcaps made of tinned steel (no organic coating) and containing no gasket or liner.
  3. An air oven conforming to ASTM D573 as specified in [4.7.3](#).

## MIL-DTL-14055G

- b. Four wheel cylinder cups shall be subjected to the tests.
1. The specimens shall be stabilized at room temperature.
  2. The specimens shall be rinsed in isopropyl alcohol or ethyl alcohol and wiped dry with a lint-free cloth.
  3. The specimens shall not remain in the alcohol for more than 30 seconds.
  4. Two of the specimens shall have the durometer hardness determined as specified in 4.7.2 and recorded.
  5. The lip and base diameters of the two specimens shall be measured to the nearest 0.001 inch (0.025mm), and the results recorded. The measurements shall be made by taking the average of two readings at right angles to each other. Base diameter measurement shall be taken within 0.015 inch (0.38 mm) from the back and parallel to the base of the specimen.
  6. Volume of the two specimens shall be determined and recorded. Volume determination shall be by weighing the specimen to the nearest milligram in air and in distilled water at room temperature, the difference being the weight of the water displaced by the specimen.
  7. Air weight shall be taken with specimen in a tared bottle.
  8. After weighing in water, the specimens shall be quickly dipped in alcohol to remove the water and dried with a lint-free cloth.
  9. Immediately after drying, each specimen shall be placed in a container and completely immersed in 2.54 oz (75 ml) of the fluid specified in MIL-PRF-46176. Containers shall be sealed to prevent vapor loss, placed in the oven and held at 248°F ± 5°F (120°C ± 3°C) for 70 hours.
  10. At the end of the 70-hour period the specimens shall be removed from their containers, rinsed in isopropyl alcohol or ethyl alcohol, wiped dry with a lint-free cloth, and the final physical properties determined within 30 minutes after removal from the fluid, to determine conformance to 3.4.4.
  11. The method of determining physical properties after testing shall be the same as before testing.
  12. The weightings shall be the last operation before and the first operation after the immersion in brake fluid and shall be accomplished without delay.
  13. The increase in volume shall be calculated as follows:

$$\text{Percent increase in volume} = \frac{(W_3 - W_4) - (W_1 - W_2)}{(W_1 - W_2)} \times 100$$

Where:  $W_1$  = initial weight in air.  
 $W_2$  = initial weight in water.  
 $W_3$  = final weight in air.  
 $W_4$  = final weight in water.

- c. Each of the remaining two specimens shall be placed in a container and completely immersed in 2.54 oz (75 ml) of the fluid specified in MIL-PRF-46176.
1. Containers shall be sealed to prevent vapor loss, placed in the oven and held at 248°F ± 5°F (120°C ± 3°C) for 70 hours.
  2. At the end of the 70 hour period, the containers shall be removed from the oven and with the cups still in the fluid, shall be allowed to stand for 24 hours at room temperature.
  3. The contents of the jar shall then be thoroughly agitated and transferred to a cone shaped centrifuge tube and the volume of sediment determined in accordance with ASTM D91.

## MIL-DTL-14055G

4.7.6 Heat-pressure stroking.4.7.6.1 Test apparatus.

- a. The test apparatus shall use the stroking fixture apparatus shown on [figure 1](#) with the components arranged as shown on [figure 2](#).
- b. The master cylinder assembly shall be one cast iron housing hydraulic brake master cylinder having a diameter of approximately 1-1/8 in (28 mm) and fitted with an uncoated steel standpipe. Master cylinder used is PIN SAE RM-15a 1-1/8 in (28 mm) diameter or equivalent.
- c. Brake assemblies:
  1. Three cast iron housing straight bore hydraulic brake wheel cylinder assemblies having a diameter approximately 1-1/8 in (28 mm).
  2. Wheel cylinder used is PIN SAE RM-14a or equivalent with stroking fixture apparatus.
  3. Three fixture units are required, including appropriate adapter mounting plates to hold the brake wheel cylinder assemblies as shown on [figure 2](#).
  4. The amount of force applied by the actuating mechanism shall be adjustable and capable of supplying sufficient stroke and thrust to the master cylinder to create a pressure of at least 1000 psi (68.95 bar) in the simulated brake system.
  5. A hydraulic gauge and pressure recorder capable of establishing the pressure curve of the system and monitoring the pressure developed shall be installed on a hydraulic line extending from the master cylinder to the outside of the oven.
  6. This line shall be provided with a shutoff valve and a bleeding valve for removing air from the connecting tubing.
  7. The actuating mechanism shall be designed to provide a stroking rate of approximately 1000 strokes/h.
  8. The pressure build up rate versus cylinder stroke and time shall correspond to the rate portrayed on [figure 3](#).
- d. The heated air bath cabinet shall be an insulated cabinet or oven having sufficient capacity to house the three wheel cylinder fixture assemblies, master cylinder and necessary connections. The following conditions shall apply.
  1. A suitable thermostatically-controlled heating system is required to maintain a motor vehicle brake fluid temperature of 248°F + 9°F (120°C + 5°C).
  2. Heaters shall be shielded to prevent direct radiation of wheel or master cylinders.
  3. Fluid temperature shall be monitored at random intervals during the test at the master cylinder reservoir, using a temperature recording device.

MIL-DTL-14055G

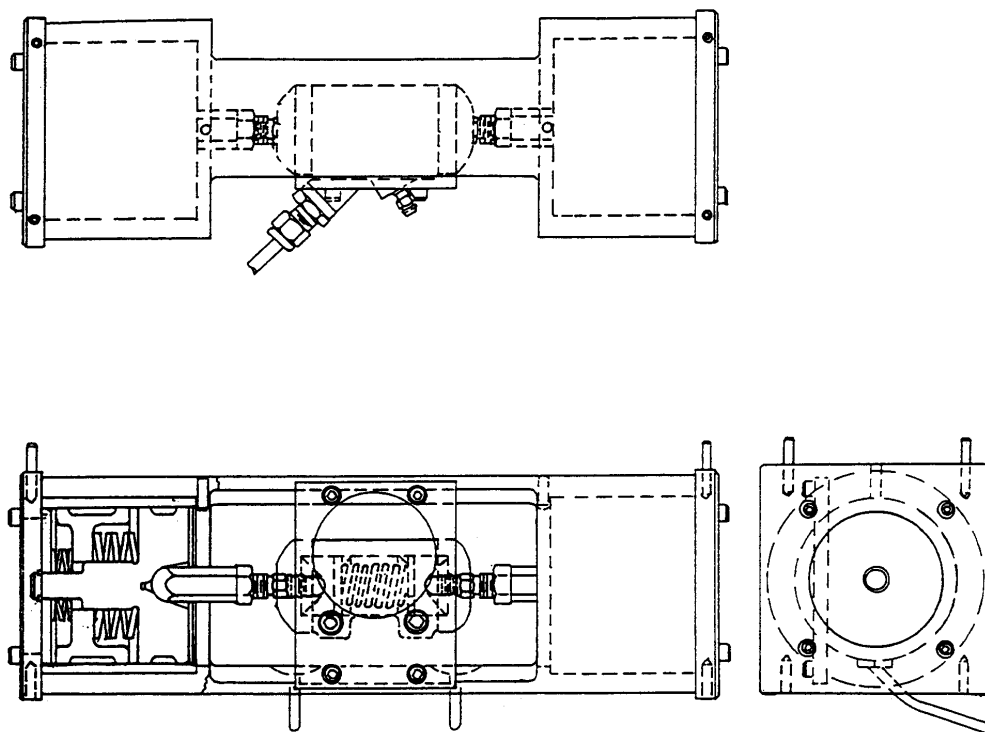

FIGURE 1. Stroking fixture apparatus.

MIL-DTL-14055G

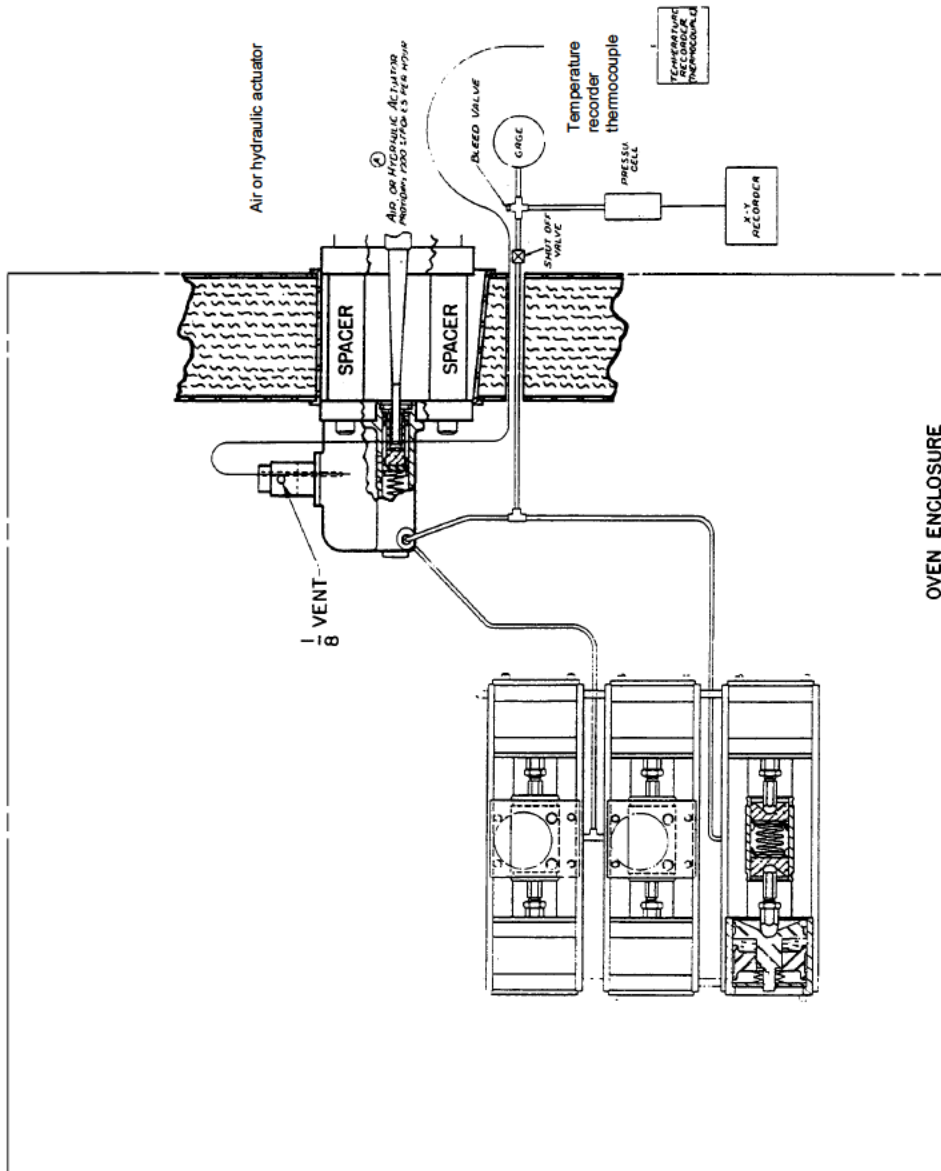

FIGURE 2. Stroking test apparatus.

MIL-DTL-14055G

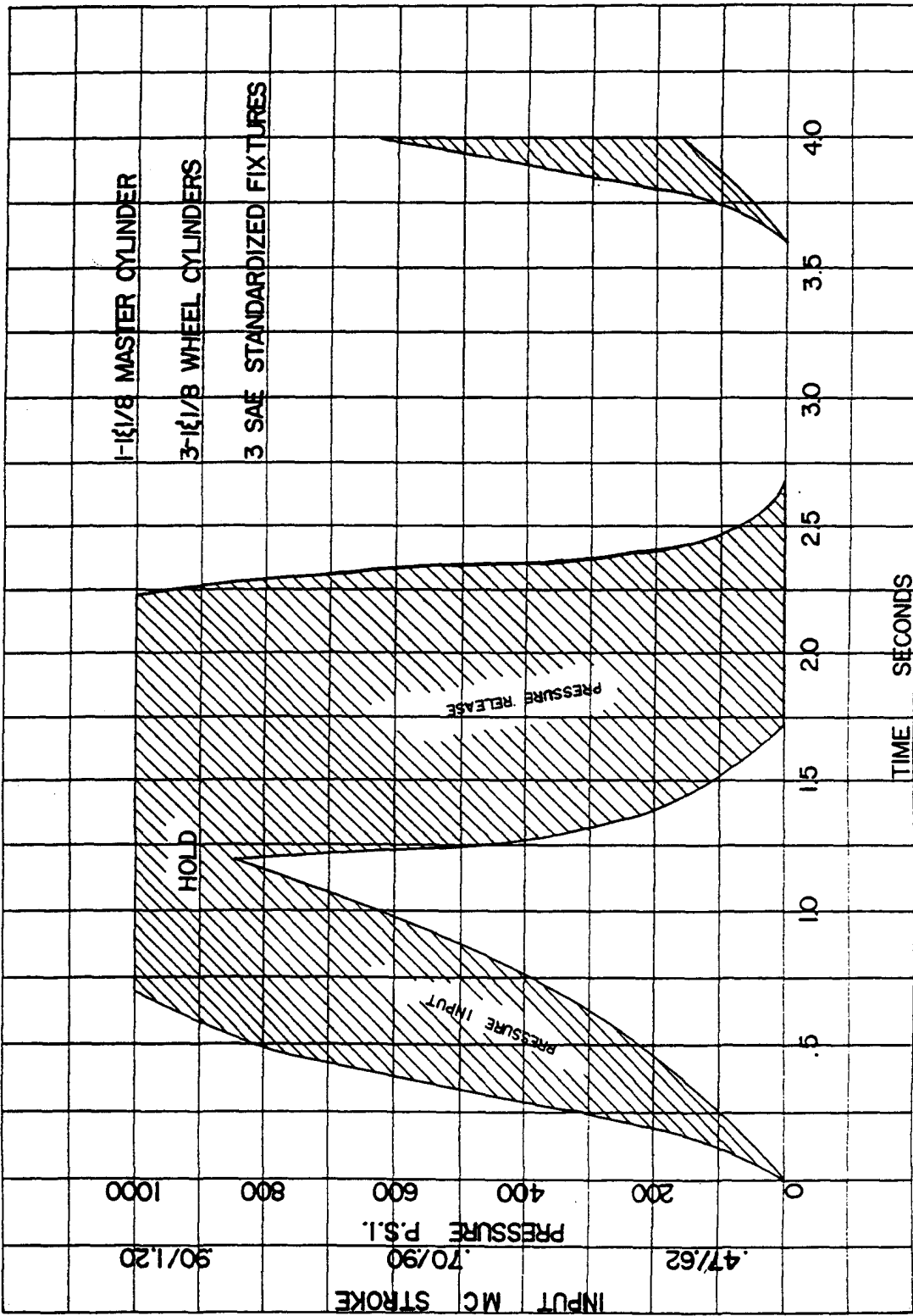

FIGURE 3. Master cylinder stroke.

## MIL-DTL-14055G

4.7.6.2 Preparation of test apparatus.4.7.6.2.1 Wheel cylinder assemblies.

- a. Use new wheel cylinder assemblies PIN SAE RM-14a or equivalent having diameters as specified in 4.7.6.1.b.
- b. Pistons (PIN SAE RM-12 or equivalent) shall be made from unanodized ASTM B209, aluminum alloy 2024-0.
- c. Disassemble cylinders and discard rubber cups.
- d. Clean all metal parts with isopropyl alcohol and dry with clean compressed air.
- e. Inspect the working surfaces of all metal parts for scoring, galling or pitting and cylinder bore roughness and discard all defective parts.
- f. Remove any stains on cylinder walls with crocus cloth and isopropyl alcohol.
- g. If stains cannot be removed, discard the cylinder.
- h. Measure the internal diameter of each cylinder at locations approximately 0.75 in (19 mm) from each of the cylinder bores, taking measurements in line with the hydraulic inlet opening and at right angles to the center line.
- i. Discard the cylinder if any of these four readings exceeds maximum or minimum limits of 1.1285 - 1.126 in (28.66 - 28.60 mm).
- j. Measure the outside diameter of each piston at two points approximately 90 degrees apart.
- k. Discard any piston if either reading exceeds maximum or minimum limits of 1.124 - 1.123 in (28.55 - 28.52mm).
- l. Select parts to insure that the clearance between each piston and mating cylinder is within 0.003 - 0.005 in (0.08 - 0.13 mm).
- m. Use new test cups that are free of lint and dirt.
- n. Discard any cups showing imperfections such as cuts, tooling marks, molding flaws or blisters.
- o. Measure the lip and base diameters of all test cups with an optical comparator or a micrometer to the nearest 0.001 in (0.025 mm) along the center line of cups and at right angles to this center line.
- p. Determine base diameter measurements within 0.032 in (0.8 mm) of the bottom edge and parallel to the base of the cup.
- q. Discard any cups if the two measured lip or base diameters differ by more than 0.003 in (0.08 mm).
- r. Average the lip and base diameters of each cup.
- s. Determine the hardness of all cups by the procedure specified in 4.7.2.
- t. Clean rubber parts with isopropyl alcohol and a lint-free cloth.
- u. Dry with clean compressed air.
- v. Dip the rubber and metal parts of the wheel cylinders, except housings, in the fluid specified in MIL-PRF-46176 and install them in accordance with manufacturer's instructions. Rubber boots shall not be used.
- w. Manually stroke the cylinders to insure that they operate easily.
- x. Install cylinders in the simulated brake system.

4.7.6.2.2 Master cylinder assembly.

- a. Use a new PIN SAE RM-15a master cylinder or equivalent having a PIN SAE RM-13 piston or equivalent made from ASTM B36/B36M copper alloy UNS No. C26800, temper H02 and new standard PIN SAE RM-4a primary master cylinder test cup or equivalent and a PIN SAE RM-5a SBR secondary master wheel cylinder test cup or equivalent, and PIN SAE RM-3 wheel cylinder test cup or equivalent as specified on figures 4, 5, and 6.
- b. Inspect and clean all parts as specified in 4.7.6.2.1.
- c. Measure each land of the master cylinder piston at two points approximately 90 degrees apart.
- d. Discard the piston if any of these readings exceed maximum or minimum limits of 1.124 - 1.123 in (28.55 - 28.52 mm).
- e. Dip the secondary cup in the test brake fluid, assemble on the piston, and maintain the assembly in a vertical position at 73.4°F ± 9°F (23°C ± 5°C) for at least two hours.

## MIL-DTL-14055G

- f. Determine the lip and base diameter of the secondary cup as installed on the piston and the primary. The lip diameter of the primary and secondary cups shall be measured and recorded to the nearest 0.001 in (0.02 mm), taking the average of two readings at right angles to each other. The lip diameter of the secondary cup shall be measured after the cup has been assembled on the piston.
- g. Inspect the relief and supply ports of the master cylinder and discard the cylinder if their ports have burrs or wire edges.
- h. Measure the internal diameter of the cylinder at two locations: approximately mid-way between the relief and supply ports and approximately 0.75 in (19 mm) beyond the relief port toward the bottom or discharge end of the bore, taking measurements at each location on the vertical and horizontal center lines of the bore.
- i. Discard the cylinder if any readings exceeds maximum or minimum limits of 1.128 - 1.125 inch (28.65 - 28.58 mm).
- j. Dip the rubber and metal parts of the master cylinder, except the housing, in the fluid specified in MIL-PRF-46176 and install them in accordance with manufacturer's instructions. Discard boot and push rod assembly.
- k. Manually stroke the master cylinder to insure that it operates easily. Install the master cylinder in the simulated brake system.

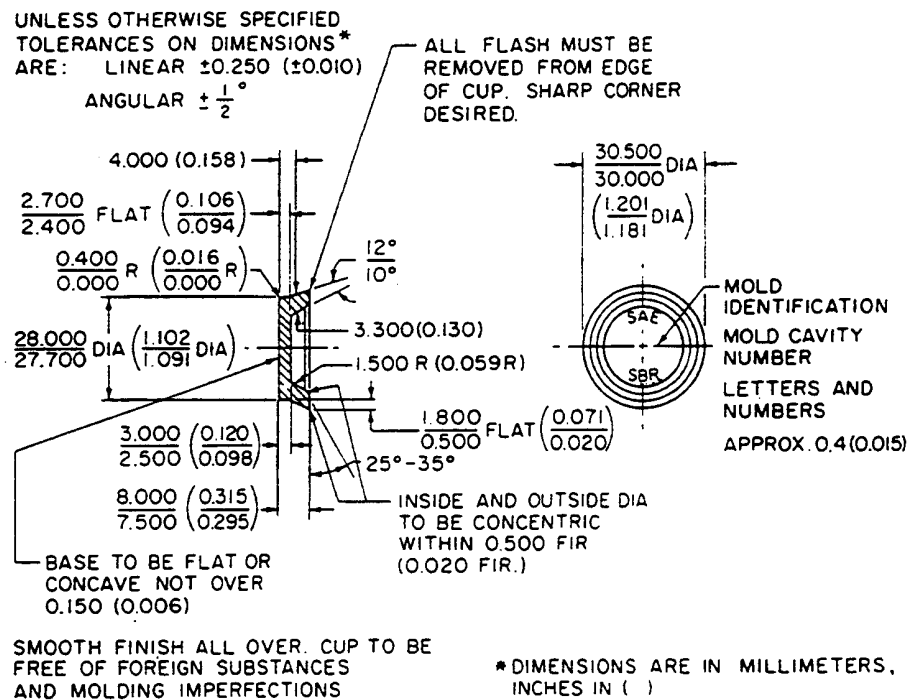

FIGURE 4. SAE test cup wheel cylinder.



MIL-DTL-14055G

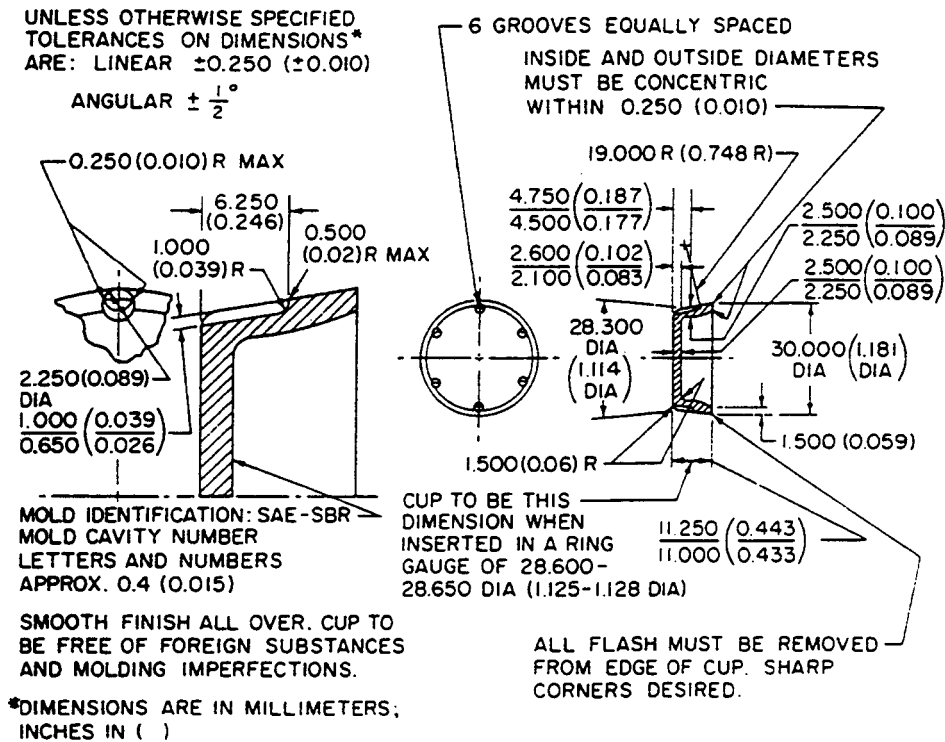

FIGURE 5. SAE test cup primary master cylinder.

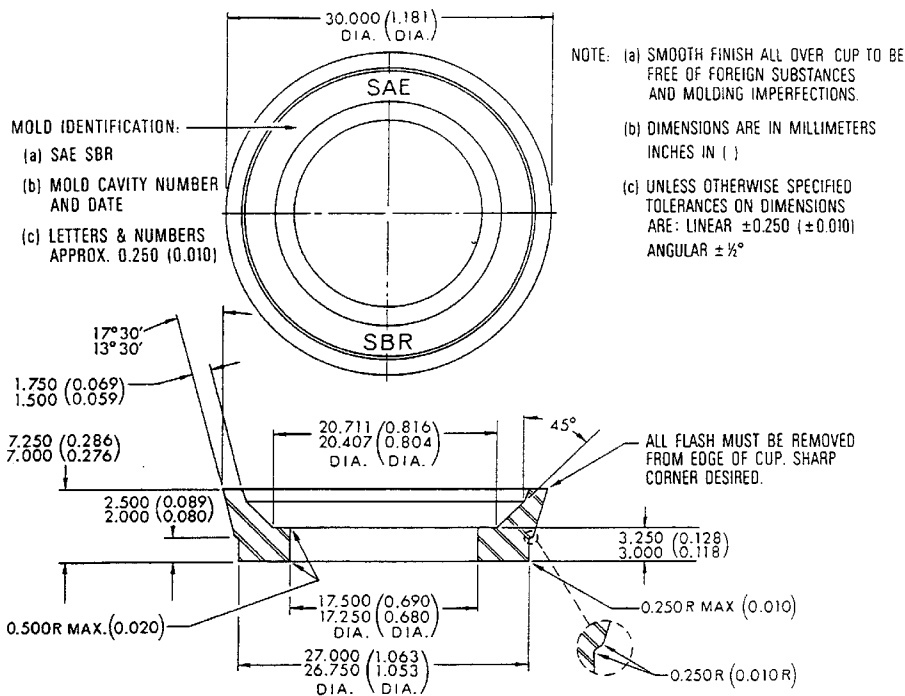

FIGURE 6. SAE test cup secondary master cylinder.

## MIL-DTL-14055G

4.7.6.2.3 Tubing. Use double wall steel tubing 1/4 inch (6.3 mm) outside diameter or 5/16 inch (7.94 mm) outside diameter meeting SAE J527. Tubing from one outlet of master cylinder to the pair of wheel cylinders or to the single wheel cylinder shall alternately be replaced with new tubing for each test (minimum length 3 feet (915 mm)). Uniformity in tubing size is desirable between master cylinder and wheel cylinder; 1/4 in (6.3 mm) tubing is more adaptable with available tube connectors. The standard PIN SAE RM-15a master cylinder has two outlets for tubing, both of which should be used.

4.7.6.2.4 Assembly and adjustment of test apparatus.

- a. Install wheel and master cylinders.
- b. Fill the system with brake fluid conforming to MIL-PRF-46176, bleeding all wheel cylinders and the pressure equipment and gauges to remove entrapped air from the system.
- c. Operate the actuator manually to apply a pressure of more than the required operating pressure and inspect the system for leaks.
- d. Adjust the actuator and pressure relief valve to obtain a pressure of  $1000 \pm 50$  psi ( $68.95 \pm 3.45$  bar) at the end of the stroke of approximately 1 in (25 mm).
- e. The pressure buildup rate versus cylinder stroke and time shall correspond to the rate portrayed on [figure 3](#).
- f. The wheel cylinder piston travel is approximately  $0.19 \pm 0.01$  in ( $4.8 \pm 0.25$  mm) when a pressure of  $1000 \pm 50$  psi ( $68.95 \pm 3.45$  bar) is reached.
- g. Adjust the stroking rate to  $1000 \pm 100$  strokes/h.
- h. Record the fluid level in the master cylinder standpipe at  $73.4^\circ\text{F} \pm 9^\circ\text{F}$  ( $23^\circ\text{C} \pm 5^\circ\text{C}$ ) with the master cylinder piston in the fully returned position.

4.7.6.3 Stroking test procedure.

- a. Run a pressure versus stroke curve utilizing the pressure recorder to determine conformance to [3.4.5.2](#):
  1. At room temperature before stroking.
  2. After the fluid is at the test temperature.
  3. Before shutdown at the test temperature.
  4. And at room temperature after stroking.
- b. Operate the system at  $16,000 \pm 1,000$  cycles at  $73.4^\circ\text{F} \pm 9^\circ\text{F}$  ( $23^\circ\text{C} \pm 5^\circ\text{C}$ ).
- c. Repair any leaks and add fluid to the master cylinder standpipe to bring the fluid level to the level originally recorded at room temperature with the piston fully returned.
- d. Start test again and raise the temperature of the fluid in the master cylinder within  $6 \pm 2$  hours to  $248^\circ\text{F} \pm 9^\circ\text{F}$  ( $120^\circ\text{C} \pm 5^\circ\text{C}$ ).
- e. During test, observe operation of the master cylinder for complete piston return and wheel cylinders for proper operation.
- f. Observe fluid level in relation to the room temperature level at random intervals.
- g. Continue the test to 94,000 total recorded strokes which shall include the number of strokes during operation at  $73.4^\circ\text{F} \pm 9^\circ\text{F}$  ( $23^\circ\text{C} \pm 5^\circ\text{C}$ ), the number of strokes required to bring the system to the operating temperature of  $248^\circ\text{F} \pm 9^\circ\text{F}$  ( $120^\circ\text{C} \pm 5^\circ\text{C}$ ), plus the number of strokes at this operating temperature.
- h. Stop the test, and with the master cylinder piston in the fully returned position to relieve retained pressure in the system, allow the equipment to cool to room temperature. Inspect to determine conformance to [3.4.5.3](#).
- i. Record the amount of fluid required to replenish any loss of fluid to the  $73.4^\circ\text{F} \pm 9^\circ\text{F}$  ( $23^\circ\text{C} \pm 5^\circ\text{C}$ ) and  $1000 \pm 50$  psi ( $68.95 \pm 3.45$  bar), examine wheel cylinders for leakage and add and record volume of fluid required to bring the fluid level to the  $73.4^\circ\text{F} \pm 9^\circ\text{F}$  ( $23^\circ\text{C} \pm 5^\circ\text{C}$ ) original level to determine conformance to [3.4.5.1](#).
- j. Within 16 hours remove the master and wheel cylinders from the system, retaining the fluid in the cylinders by immediately capping or plugging the ports.
- k. Disassemble the cylinders, collecting the fluid from the master cylinder and wheel cylinders in a glass jar.

## MIL-DTL-14055G

- l. Record any sludge, jell, or abrasive grit present in the test fluid.
- m. When collecting the stroked fluid, all the residue which has deposited on the rubber and metal internal parts should be removed by rinsing and agitating such parts in the stroked fluid and using a soft brush to assure that all loose adhering sediment is collected.
- n. Clean rubber cups in isopropyl alcohol and dry with clean, compressed air.
- o. Inspect cups for tackiness, scoring, scuffing, blistering, cracking, chipping, (heel abrasions), and change in shape from original appearance to determine conformance to 3.4.5.5.
- p. Within 1 hour after disassembly, measure the lip and base diameter of each cylinder cup by the procedure specified in 4.7.6.2.2 with the exception that the lip or base diameters of cups may differ by more than 0.003 in (0.08 mm) to determine conformance to 3.4.5.4.
- q. Determine the hardness of each cup by the procedure specified in 4.7.2 to determine conformance to 3.4.5.6.
- r. Within 1 hour after draining cylinders, agitate fluid in glass jar to suspend and uniformly disperse sediment and transfer a 100 ml portion of this fluid to an ASTM cone-shaped centrifuge tube and determine percent sediment as described in ASTM D91 to determine conformance to 3.4.5.8.
- s. Inspect cylinder parts, recording any gum deposits.
- t. Rub any deposits adhering to cylinder walls with a cloth wetted with isopropyl alcohol to determine abrasiveness and removability.
- u. Clean cylinder parts in isopropyl alcohol and dry with compressed air, and inspect for pitting and scoring on pistons and cylinder walls to determine conformance to 3.4.5.7.
- v. Measure and record diameters of pistons and cylinders by the procedures specified in 4.7.6.2.1 and 4.7.6.2.2.

4.7.7 Corrosiveness.

4.7.7.1 Rubber cups. Three rubber cups are required. The base diameter and the hardness of the cups shall be determined prior to testing.

4.7.7.2 Metal Strips. Three strips of each of the following metals are required:

TABLE VIII. Metals.

Metal	Description
Tin Plate	ASTM A624/A624M
Carbon steel	ASTM A1008/A1008M
Aluminum alloy	ASTM B209
Cast iron	SAE J431, G11H18
Brass	ASTM B36/B36M, Copper Alloy UNS No. C26800, temper 1102.
Copper	ASTM B152/B152M, Copper UNS No. C11400

- a. Each strip shall measure 3 inches by 1/2 inch by less than 1/4 inch (76 mm X 12.8mm X less than 6.4 mm).
- b. A hole 3/16 inch (4.8 mm) in diameter, centered 1/4 inch (6.4 mm) from one end, shall be drilled in each strip.
- c. All strips, with the exception of the tinned iron strips, shall be cleaned by abrading with 320A water proof carborundum paper and Stoddard solvent, until all surface scratches, cuts and pits are removed from the strips.
- d. The strips shall then be polished with 00 grade steel wool.
- e. All strips, including the tinned iron, shall then be rinsed with isopropyl alcohol or 95 percent ethyl alcohol and dried with a clean lint-free cloth and brought to constant weight in desiccators.

## MIL-DTL-14055G

4.7.7.3 Procedure.

- a. When the strips are ready for testing, weigh them to the nearest 0.1 mg.
- b. Fasten one strip of each of the metals together through the holes in the strips, using an uncoated cotter pin or a Size Number 6 or 8 uncoated mild steel bolt with nut, to ensure electrolytic contact between the strips.
- c. The strips shall be arranged on the pin in the same order in which they are listed above (see [4.7.7.2](#)) and shall be bent as required so that there will be a separation of at least 1/8 inch (3 mm) between adjacent strips for a distance of approximately 2-1/4 inches (60 mm) measured from the free end of the strips.
- d. The three sets of assembled strips shall then be placed in separate screw cap jars of approximately 1-pint capacity.
- e. The screw caps shall be made of tinned steel (no organic coating), containing no gasket or liner, and shall have a 1/32-inch (0.8 mm) hole drilled near the center of the cap.
- f. One wheel cylinder cup shall be placed in the container in such a manner that the pinned ends of the strips rest in and, are in contact with the concavity of the cup.
- g. A sufficient amount of brake fluid meeting the requirements of MIL-PRF-46176 shall be poured into each jar to a depth of 1/2 inch (12.7 mm) above the tops of the assembled strips.
- h. The lids of the jars shall then be secured and the jars placed for  $120 \pm 2$  hours in a gravity convection oven maintained at a temperature of  $212^{\circ}\text{F} \pm 3.6^{\circ}\text{F}$  ( $100^{\circ}\text{C} \pm 2^{\circ}\text{C}$ ). Following the test period, the metal strips and the rubber cups shall be removed from the jars.
- i. The metal strips shall be disassembled, cleaned of all adhering sediment, sludge, and corroded particles, by being first flushed with water and wiped with a cloth wetted with isopropyl alcohol or 95 percent ethyl alcohol.
- j. The strips shall then be visually examined for evidence of corrosion, pitting, or etching.
- k. The strips shall be brought to constant weight in a desiccators and then weighed to nearest 0.1 milligram.
- l. Calculate the weight loss per unit area of each strip by dividing the observed loss in weight of the strip (in milligrams) by its total surface area (in square centimeters).
- m. The average of the three determinations made in each type of metal specimen shall be calculated and recorded as the average weight loss in milligrams per square centimeter to determine conformance to [3.4.6.1](#).
- n. The three rubber cups, when removed from the fluid, shall be quickly washed with isopropyl alcohol or 95 percent ethyl alcohol, dried with a clean lint-free cloth, and visually examined for evidence of sloughing, softening, tackiness, and disintegration to determine conformance to [3.4.6.2](#).
- o. The base diameter and hardness of the rubber cups shall be measured to determine compliance with the requirements specified in [3.4.6.2](#).
- p. These measurements shall be made within 10 minutes following removal of the cups from the fluid.
- q. One-hundred milliliters of test fluid-water mixture shall be centrifuged in a cone-shaped centrifuge tube and the volume of sediment determined in accordance with ASTM D91 to determine conformance to [3.4.6.3](#).

4.7.8 Storage corrosion.

4.7.8.1 Apparatus. The apparatus shall include a humidity cabinet capable of maintaining 70°F to 115°F (21°C - 46°C) at 95 percent humidity; three cylinder assemblies of proper size for the size of cups being tested; containing unanodized aluminum pistons and hydraulic assembly fluid conforming to MIL-PRF-46176.

## MIL-DTL-14055G

4.7.8.2 Procedure.

- a. Disassemble the three cylinder assemblies and, using a lint-free cloth, wipe all fluid from the cylinders, pistons, boots, and springs.
- b. Cylinders or parts showing light stains or corrosion shall be discarded.
- c. Assemble the six test cups into the wheel cylinders using a light film of brake fluid conforming to MIL-PRF-46176 to completely coat the cylinder walls, cups, springs, and pistons.
- d. Assemble the clean boots onto the cylinders to hold the pistons in position.
- e. Leave one inlet hole open and close the remaining holes with a suitable rubber or metal plug.
- f. Number the cylinders 1 through 3.
- g. Adjust the humidity cabinet to 115°F (46°C) and 95 percent humidity.
- h. Place the cylinders in the cabinet with open holes facing down.
- i. Maintain the temperature and humidity at above levels for 16 hours.
- j. Readjust the cabinet controls to 70°F (21°C) and 95 percent humidity and maintain these conditions for 8 hours to complete the first cycle.
- k. Repeat this 24-hour cycle for 12 days.
- l. When the foregoing cycling is interrupted due to the incidence of one or more nonworking days, the cups shall remain in the humidity cabinet with the cabinet controls set to maintain 70°F (21°C) at 95 percent humidity until cycling is resumed on the following working day
- m. For inspection purposes number 1 cylinder assembly shall be removed from the humidity cabinet at the end of six cycles, number 2 cylinder assembly at the end of the 10 cycles and number 3 cylinder assembly at the end of 12 cycles.
- n. In case this inspection would fall on a nonworking day, the inspection shall be made on the following working day.
- o. Cylinder assemblies shall be inspected as follows:
  1. During removal from the humidity cabinet and subsequent disassembly, and inspection operations, the cylinders shall be maintained in the same position as they were in the cabinet to avoid fluid contamination of the inside of the cylinder.
  2. The pistons and cups shall be removed from the cylinder by pulling them out from their respective ends. Slight air (dry) pressure may be applied internally in the cylinder, if necessary, to aid in the removal of cups and pistons.
  3. To determine conformance to 3.4.7 inspect the cylinder bore under a strong light for corrosion, discoloration, or spots, particularly noting the area of the fluid ring left by the lip of the cup during its exposure in the humidity cabinet.

## 5. PACKAGING

5.1 Packaging. For acquisition purposes, the packaging requirements shall be as specified in the contract or order (see 6.2). When packaging of material is to be performed by DoD or in-house contractor personnel, these personnel need to contact the responsible packaging activity to ascertain packaging requirements. Packaging requirements are maintained by the Inventory Control Point's packaging activity within the Military Service or Defense Agency, or within the Military Service's System Commands. Packaging data retrieval is available from the managing Military Department's or Defense Agency's automated packaging files, CD-ROM products, or by contacting the responsible packaging activity.

## 6. NOTES

(This section contains information of a general or explanatory nature that may be helpful, but is not mandatory.)

## MIL-DTL-14055G

6.1 Intended use. The wheel cylinder cups, master cylinder primary cups, and master cylinder secondary cups are intended for use in wheel cylinders, master cylinders, and slave cylinders in hydraulic-brake systems of trucks and other heavy-duty automotive equipment where the cylinder cups are subjected to temperatures ranging from +248°F to -67° F (+120°C to - 55°C). Wheel cylinder cups, master cylinder primary cups, and master cylinder secondary cups that are intended for use for commercial hydraulic components are not designed to withstand these extreme conditions or sudden environmental changes, and could experience catastrophic failure.

6.2 Acquisition requirements. Acquisition documents should specify the following:

- a. Title, number, and date of this specification.
- b. Size of cups.
- c. Packaging requirements ([see 5.1](#)).

6.3 Qualification. With respect to products requiring qualification, awards will be made only for products which are, at the time of award of contract, qualified for inclusion in Qualified Products List No. 14055, whether or not such products have actually been so listed by that date. The attention of contractors is called to these requirements; and manufacturers are urged to arrange to have the products that they propose to offer to the Federal Government tested for qualification in order that they may be eligible to be awarded contracts or orders for the products covered by this specification. Information pertaining to qualification of products may be obtained from DLA Land and Maritime, P.O. Box 3990, ATTN: VQ, Columbus, Ohio 43218-3990 or emailed to [vqp.chief@dla.mil](mailto:vqp.chief@dla.mil). An online listing of products qualified to this specification may be found in the Qualified Products Database (QPD) at <https://assist.dla.mil>.

6.3.1 Provisions governing qualification (SD-6). Copies of "Provisions Governing Qualification" are available online at <https://assist.dla.mil> or from the Standardization Document Order Desk, 700 Robbins Avenue, Building 4D, Philadelphia, PA 19111-5094.

6.4 Environmentally preferable material. Environmentally preferable materials should be used to the maximum extent possible to meet the requirements of this specification. As of the dating of this document, the U.S. Environmental Protection Agency (EPA) is focusing efforts on reducing 31 priority chemicals. The list of chemicals and additional information is available on their website <http://www.epa.gov/osw/hazard/wastemin/priority.htm>. Included in the EPA list of 31 priority chemicals are cadmium, lead, and mercury. Use of these materials should be minimized or eliminated unless needed to meet the requirements specified herein ([see section 3](#)).

6.5 Equivalent test methods. The index of test methods in FED-STD-791 lists the corresponding equivalent test methods of the American Society for Testing and Materials where applicable.

6.6 Test materials. Metal strips, the standard compatibility fluid, and suitable test jars can be obtained from the Society of Automotive Engineers, 400 Commonwealth Drive, Warrendale, PA 15096.

6.7 Subject term (key word) listing.

fluid  
Isopropanol

6.8 Changes from previous issues. The margins of this specification are marked with vertical lines to indicate where changes from the previous issue were made. This was done as a convenience only and the Government assumes no liability whatsoever for any inaccuracies in these notations. Bidders and contractors are cautioned to evaluate the requirements of this document based on the entire content irrespective of the marginal notations and relationship to the last previous issue.

MIL-DTL-14055G

CONCLUDING MATERIAL

Custodians:

Army – AT  
Navy – SH  
Air Force - 99  
DLA - CC

Preparing activity:

DLA - CC

Review activities:

Army – AR  
Navy – MC, SA, YD  
Air Force – 71

Project 2530-2013-002

NOTE: The activities listed above were interested in this document as of the date of this document. Since organizations and responsibilities can change, you should verify the currency of the information above using the ASSIST Online database at <https://assist.dla.mil>.