

INCH-POUND

MIL-DTL-12133/6A
 19 October 2015
 SUPERSEDING
 MIL-W-12133/6
 24 April 1986

DETAIL SPECIFICATION SHEET

WASHER, SPRING TENSION, WAVE, SPRING STEEL

This specification is approved for use by all Departments and Agencies of the Department of Defense.

The requirements for acquiring the product described herein shall consist of this specification sheet and procurement specification MIL-DTL-12133.

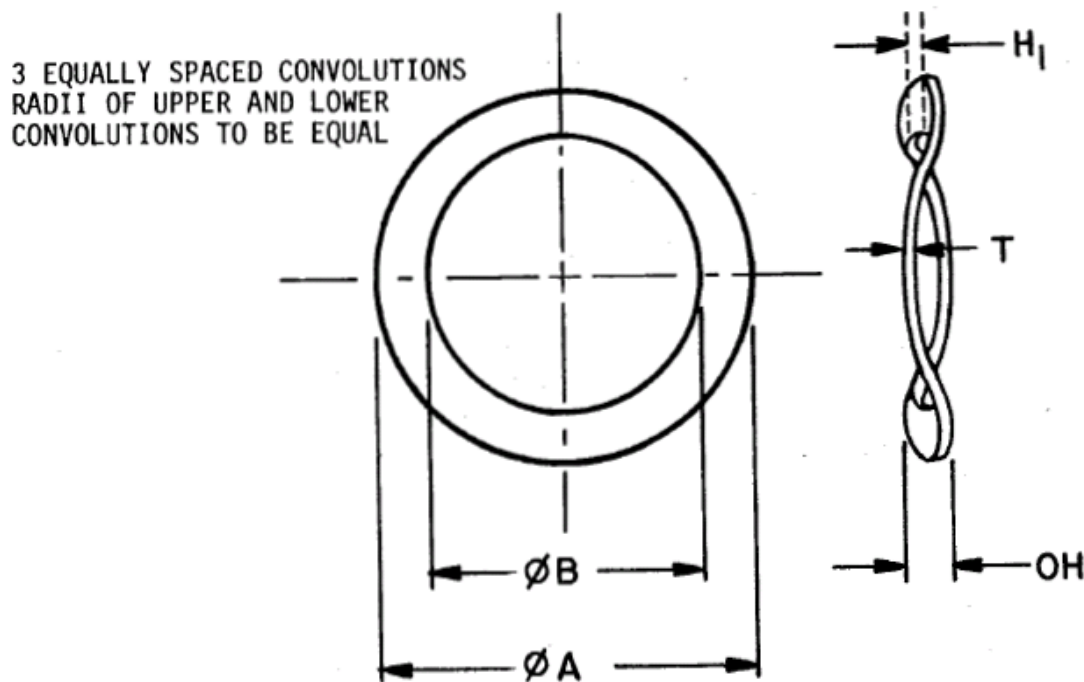

FIGURE 1. WASHER, SPRING TENSION, WAVE, SPRING STEEL.

MIL-DTL-12133/6A

TABLE I. DASH NUMBERS AND DIMENSIONS.

Dash No	Ø A OD ±.010	Ø B ID ±.010	T Thk ±.001	OH		Hi Test Deflection	Load At Hi Lb
				Free Hgt	Tol		
01	.265	.187	.008	.060	±.003	.030	6-14
02	.367	.265	.006	.030		.015	2-4
03	.500	.265	.010	.035		.017	20-25
04	.492	.350	.007	.035		.020	3-5
05	.618	.440	.008	.040		.025	3-5
06	.734	.531	.009	.050		.030	4-7
07	.855	.650	.010	.060		.030	4-7
08	.925	.719	.010	.066		.033	6-9
09	1.102	.856	.012	.075	±.006	.037	9-13
10	1.159	.901	.013	.080		.040	10-14
11	1.235	.961	.014	.087		.043	13-17
12	1.351	1.051	.014	.099		.048	16-20
13	1.593	1.239	.018	.110		.055	21-27
14	1.621	1.261	.019	.112		.056	22-28
15	2.132	1.658	.023	.148		.073	33-43
16	2.645	2.057	.028	.184		.090	50-64
17	3.917	3.047	.042	.258		.128	105-135
18	4.997	3.890	.050	.355		.172	156-198
19	5.817	4.530	.055	.440		.209	191-243

MIL-DTL-12133/6A

REQUIREMENTS:

1. Material. Spring steel (see MIL-DTL-12133).
2. Protective coating and surface treatment. Plain, Cadmium plate or Zinc coating (see MIL-DTL-12133).
3. Part number: The part number consists of the letter "M", the basic number of this specification sheet, followed by a dash number taken from Table I and a finish code letter, "P" for Plain, "C" for Cadmium plate, "A" for Zinc coating.

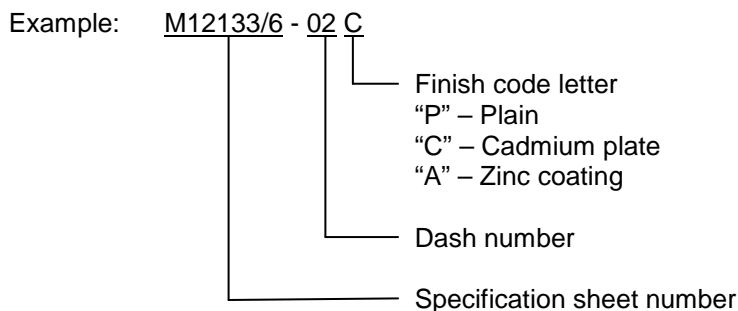

M12133/6-02C Indicates – Washer, Spring Tension, Wave, Spring Steel; .367 OD; .265 ID; .006 thick; .030 free height; Cadmium plate.

NOTES:

1. All dimensions are in inches.
2. CHANGES FROM PREVIOUS ISSUE. Marginal notations are not used in this revision to identify changes with respect to the previous issue due to the extent of the changes.

MILITARY INTEREST

Custodians:

Army - AR
 Navy - OS
 Air Force - 99

Preparing activity:

DLA - IS

(Project 5310-2015-010)

NOTE: The activities listed above were interested in this document as of the date of this document. Since organizations and responsibilities can change, you should verify the currency of the information above using the ASSIST Online database at <https://assist.dla.mil>.