

INCH-POUND
------------

MIL-DTL-10215L  
15 August 2008  
SUPERSEDING  
MIL-DTL-10215K  
20 November 2003

## DETAIL SPECIFICATION

### SPEEDOMETERS, TACHOMETERS, FLEXIBLE SHAFT ASSEMBLIES, FLEXIBLE SHAFT ASSEMBLY CORES AND ADAPTERS

This specification is approved for use by all departments and agencies of the Department of Defense.

#### 1. SCOPE

1.1 Scope. This specification covers mechanical speedometers and tachometers, flexible shaft assemblies, flexible shaft assembly cores and adapters.

1.2 Classification. The speedometers, tachometers, shaft assemblies, cores and adapters are of the groups and classes as specified below (see 6.2).

1.2.1 Groups. The groups of speedometers, tachometers, flexible shaft assemblies, cores and adapters are as follows:

Group A - Speedometer, 0-60 miles per hour (mph), fixed mounting

Group B - Tachometer, fixed mounting

Group F - Flexible shaft assemblies, flexible shaft assembly cores, and adapters

Comments, suggestions, or questions on this document should be addressed to Defense Supply Center Richmond, ATTN: DSCR-VEB, 8000 Jefferson Davis Highway, Richmond, VA 23297-5616, or e-mailed to <a href="mailto:STDZNMGT@dla.mil">STDZNMGT@dla.mil</a> . Since contact information can change, you may want to verify the currency of this address information using the ASSIST database at <a href="http://assist.daps.dla.mil/">http://assist.daps.dla.mil/</a> .
-----------------------------------------------------------------------------------------------------------------------------------------------------------------------------------------------------------------------------------------------------------------------------------------------------------------------------------------------------------------------------------------------------------------------------------------------------------------------

## MIL-DTL-10215L

1.2.2 Classes. The classes of shaft assemblies (flexible, metallic or plastic), cores and adapters are as follows:

- Class 1 - Shaft assembly, flexible, metallic
- Class 4 - Core, flexible shaft assembly
- Class 5 - Adapter, speedometer, and tachometer, 90 degree drive
- Class 7 - Adapter, speedometer, and tachometer, straight drive
- Class 8 - Adapter, coupling/bulkhead, speedometer and tachometer drive
- Class 9 - Shaft assembly, flexible, plastic

1.3 Part or identifying number (PIN). The PIN to be used for instruments acquired to this specification is created as follows:

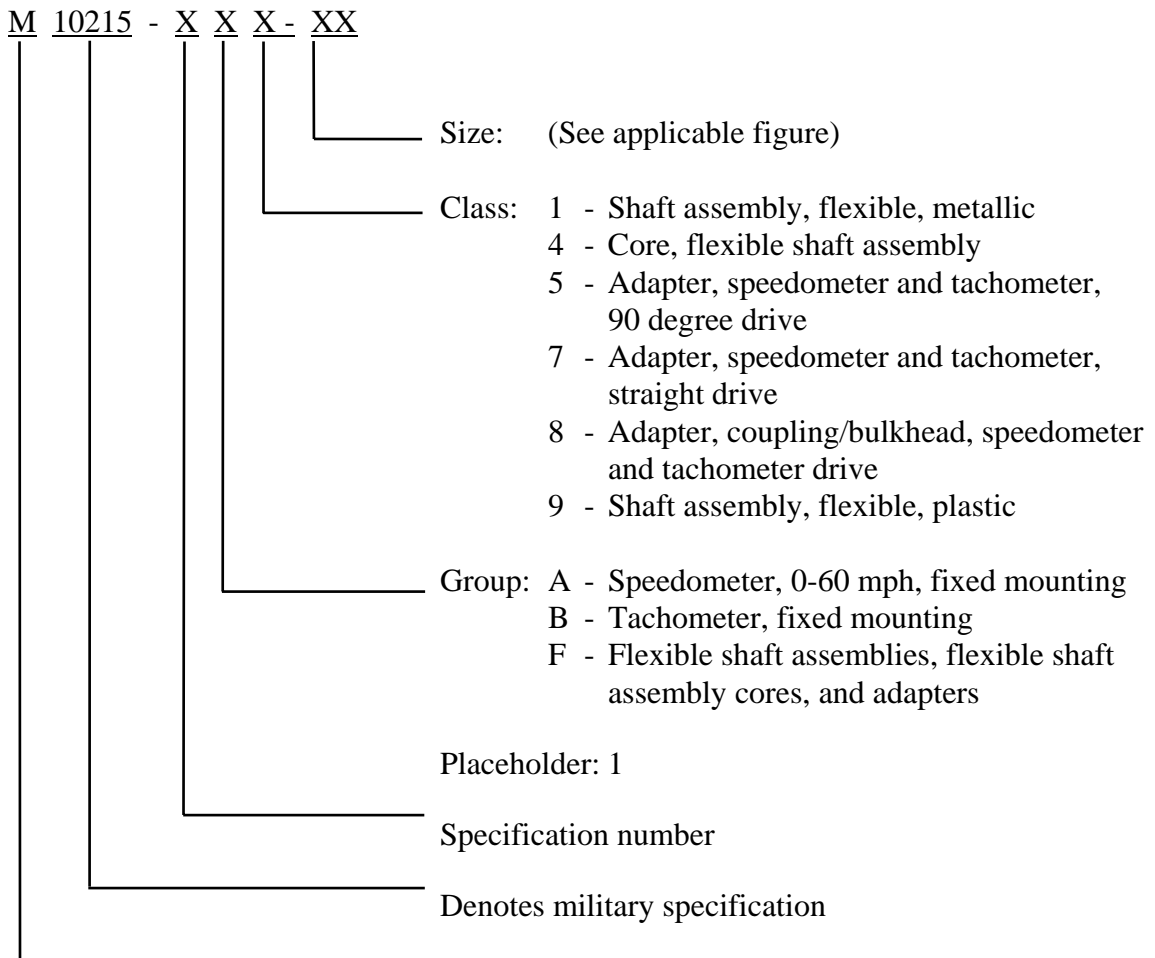

## 2. APPLICABLE DOCUMENTS

2.1 General. The documents listed in this section are specified in sections 3, 4 or 5 of this standard. This section does not include documents cited in other sections of this standard or recommended for additional information or as examples. While every effort has been made to ensure the completeness of this list, document users are cautioned they must meet all specified requirements of the documents cited in sections 3, 4 or 5 of this specification, whether or not they are listed.

## MIL-DTL-10215L

### 2.2 Government documents.

2.2.1 Specifications and standards. The following specifications and standards form a part of this document to the extent specified herein. Unless otherwise specified, the issues of these documents are those cited in the solicitation or contract.

#### FEDERAL SPECIFICATIONS

L-P-380 - Plastic Molding Material Methacrylate.

#### FEDERAL STANDARDS

FED-STD-595 - Colors Used in Government Procurement (Color chip 37875).

#### DEPARTMENT OF DEFENSE SPECIFICATIONS

MIL-W-80 - Window, Observation, Acrylic Base, Antielectrostatic, Transparent (for Indicating Instrument).

DOD-P-15328 - Primer (Wash), Pretreatment (Formula No. 117 for Metals) (Metric).

MIL-PRF-22750 - Coating, Epoxy, High-Solids.

MIL-PRF-23827 - Grease, Aircraft and Instrument, Gear and Actuator Screw.

MIL-DTL-53039 - Coating, Aliphatic Polyurethane, Single Component, Chemical Agent Resistant.

MIL-DTL-64159 - Coating, Water Dispersible Aliphatic Polyurethane, Chemical Agent Resistant.

#### DEPARTMENT OF DEFENSE STANDARDS

MIL-STD-130 - Identification Marking of U.S. Military Property.

MIL-STD-202 - Test Method Standard - Electronic and Electrical Component Parts.

(Copies of these documents are available online at <http://assist.daps.dla.mil/quicksearch/> or [www.dodssp.daps.mil](http://www.dodssp.daps.mil) or from the Standardization Document Order Desk, 700 Robbins Avenue, Building 4D, Philadelphia, PA 19111-5094.)

2.2.2 Other government documents and drawings. The following other government drawing, form a part of this document to the extent specified herein. Unless otherwise specified, the issues are those cited in the solicitation or contract.

## MIL-DTL-10215L

### DRAWING

#### ARMY

12369000 - Chemical Agent Resistant Coatings (CARC) Paint Systems Index.

(Copies of the drawing are available from US Army Tank-Automotive & Armaments Command, Attn: AMSTA-TR-E/ESA, 6501 East 11 Mile Road, Warren, MI 48397-5000.)

### STANDARDIZATION DOCUMENT

SD-6 - Provisions Governing Qualification.

(Copies of this document are available at <http://assist.daps.dla.mil/quicksearch> or [www.dodssp.daps.mil](http://www.dodssp.daps.mil) or from the Standardization Document Order Desk, 700 Robbins Avenue, Building 4D, Philadelphia, PA 19111-5094.)

2.3 Non-government publications. The following documents form a part of this document to the extent specified herein. Unless otherwise specified, the issues of these documents are those cited in the solicitation or contract.

#### ASTM INTERNATIONAL

ASTM A 380 - Standard Practice for Cleaning, Descaling, and Passivation of Stainless Steel Parts, Equipment, and Systems.  
ASTM B 117 - Standard Practice for Operating Salt Spray (Fog) Apparatus.  
ASTM D 3935 - Standard Specification for Polycarbonate (PC) Unfilled and Reinforced Material.  
ASTM G 21 - Standard Practice for Determining Resistance of Synthetic Polymeric Materials to Fungi.

(Copies of these documents are available online at <http://www.astm.org/> or from ASTM International, 100 Barr Harbor Drive, P.O. Box C700, West Conshohocken, PA 19428-2959.)

2.4 Order of precedence. In the event of a conflict between the text of this document and the references cited herein, the text of this document takes precedence. Nothing in this document, however, supersedes applicable laws and regulations unless a specific exemption has been obtained.

## MIL-DTL-10215L

## 3. REQUIREMENTS

3.1 Qualification. Components furnished under this specification shall be products authorized by the qualifying activity for listing on the applicable qualified products list (QPL) before contract award (see 4.3 and 6.3).

3.2 Materials. Unless otherwise specified herein, materials shall be in accordance with the manufacturer's standard practice.

3.2.1 Dial. The dial shall be fabricated from metal.

3.2.2 Case window. The case window shall be fabricated from clear plastic conforming to MIL-W-80 or, if molded, conforming to type I, class 3 of L-P-380 or group 1, class 1 of ASTM D 3935.

3.2.3 Recycled, recovered or environmentally preferable materials. Recycled, recovered or environmentally preferable materials should be used to the maximum extent possible provided the material meets or exceeds the operational and maintenance requirements and promotes economically advantageous life cycle costs.

3.3 Design and construction. The design and construction of the instruments and components shall be in accordance with the interface and envelope dimensions in figures 1 through 9; however, the figures are not intended to limit the manufacturer's design.

3.3.1 Speedometer and tachometer.

3.3.1.1 Mounting and connector. The instruments shall be provided with a bezel, a means for mounting and a connector for attachment of a flexible drive shaft assembly.

3.3.1.2 Case.

3.3.1.2.1 Case window. A case window shall be provided to facilitate illumination of the dial from an outside source.

3.3.1.2.2 Dehumidifier. Means shall be provided to dehumidify trapped air after the speedometer or tachometer is sealed. The dehumidification component shall be secured so that it will not become loose when the speedometer or tachometer is subjected to vibration.

## MIL-DTL-10215L

3.3.1.3 Dial.

3.3.1.3.1 Marking. The face of the dial shall include the markings specified in figures 8 through 9 and table 1. The printing shall be commercial style lettering of the size specified in table I. The dial face shall have a black background with numerals, letters, and graduations conforming to color number 37875 of FED-STD-595.

TABLE I. Dial face marking.

Marking	Height (inches)	Height (mm)
Numerals for mph scale	7/32	5.6
Graduations, major, mph scale	7/32	5.6
Graduations, minor, mph scale	1/8	3.2
"Miles per hour" or "MPH"	1/8	3.2
"Revolutions per minute" or "RPM"	1/8	3.2
"Hours" and "10th" or "100 <sup>th</sup> "	3/32	2.4
"Miles" and "10th"	3/32	2.4
MS or military part number	3/32	2.4
Manufacturer's identification	1/16 (max.)	1.6

3.3.1.3.2 Fastening. The dial shall be secured to the body of the speedometer or tachometer in such a position that the marking on the face of the dial and the numerals on the odometer or engine hour meter shall be legible when illuminated through the case window from an outside source.

3.3.1.4 Pointer. The pointer shall be attached to the indicator movement and shall be damped to reduce oscillation from vibration. The pointer shall not touch the dial or window. The shape of the pointer shall facilitate reading of any point in the range of the dial. Not less than the top half of the visible portion of the pointer shall be white conforming to color number 37875 of FED-STD-595.

3.3.1.4.1 Damping. The pointer shall be damped to prevent an oscillation of more than  $\pm 0.5$  mph above 10 on the speedometer dial, or  $\pm 30$  revolutions per minute (rpm) above 500 rpm on the tachometer dial when the speedometer or tachometer is operated directly off a drive shaft, with no fluctuation in speed.

3.3.1.5 Recording devices.

3.3.1.5.1 Odometer. The instrument, when furnished for use with a speedometer, shall be of the nonreset-type, consisting of six numeral wheels located in the dial as shown in figure 8. The odometer shall register actual mileage within  $\pm 0.1$  percent. The odometer shall totalize and record up to 99,999.9 in multiples of 0.1 mile before automatically turning to zero.

3.3.1.5.2 Engine hour meter. The engine hour meter shall accurately record hours of engine operation within  $\pm 2$  percent. The engine hour meter shall totalize and record up to

## MIL-DTL-10215L

9,999.9 hours in multiples of 0.1 hour or up to 9,999.99 hours in multiples of 0.01 hour before automatically turning to zero.

3.3.2 Drive mechanism. A flexible shaft assembly shall drive speedometers and tachometers with adapters as required.

3.3.2.1 Flexible shaft assembly. The flexible shaft assembly shall consist of a flexible outer casing and a flexible inner core. The outer casing shall be equipped with reusable means for attaching the assembly to both the instrument and the take-off point. The configuration shall fall within the envelope limits indicated in figures 1, 2 or 3, as applicable. End connections affecting interchangeability shall conform to the interface requirements in figures 1, 2 and 3. A means shall be provided in the assembly to prevent the core from falling out.

3.3.2.1.1 Flexible shaft assembly, oscillation. When the flexible shaft assembly is tested as specified in 4.5.3.2.1, pointer oscillation shall not exceed 1 mph at speeds above 10 mph on the speedometer dial and shall not exceed 50 rpm on the tachometer dial at rotating speeds above 500 rpm.

3.3.2.1.2 Core. The flexible shaft assembly core shall conform to figure 4. The outer layer of core wires shall be wound in the direction of right hand lay.

3.3.2.2 Adapters. Adapters shall conform to figures 5, 6 or 7, as applicable.

### 3.4 Performance.

3.4.1 Calibration. When tested as specified in 4.5.2.1 and under the conditions as specified in 4.2.1, the calibration of the instruments shall be such as to meet the following performance requirements.

3.4.1.1 Speedometers. When tested as specified in 4.5.2.1.1, the speedometer pointer shall accurately indicate the vehicle speed specified in table II within the specified calibration limits when the drive shaft is driven at the specified speeds after the speedometer temperature has been stabilized at 77 °F and 160 °F. An additional 3 mph tolerance above or below the recorded speed at 77 °F shall be allowed when the speedometer is tested at or above 160 °F. The pointer shall leave the stop at or before the moment when the drive shaft is being driven at a speed for which the correct indicated speed is 3 mph.

TABLE II. Speedometer calibration limits.

Drive shaft speed (rpm)	Calibration limits at 77 °F	
	(mph)	
167	10	+1 to -1
500	30	+2 to -1
1,000	60	+3 to -0

## MIL-DTL-10215L

3.4.1.2 Odometer. When tested as specified in 4.5.2.1.2, the odometer shall register within a tolerance of +1 percent.

3.4.1.3 Tachometers. When tested as specified in 4.5.2.1.3, the tachometer pointer shall accurately indicate a rotating speed on the dial twice that of the drive shaft within a tolerance of  $\pm 60$  rpm. The drive shaft shall be rotated at 250, 1,000, and 1,500 rpm. The test shall be conducted with the tachometer temperature stabilized at ambient air temperatures of 77 °F, and 160 °F. When tested at or above, 160 °F, an additional tolerance is required. These calibration tolerances are determined by multiplying the initial reading by 5 percent and adding or subtracting it to/from the initial tolerance upper and lower limits. The pointer shall leave the stop at or before the moment when the drive shaft is being driven at a speed for which the correct indicated speed is 100 rpm.

3.4.1.4 Engine hour meter. When tested as specified in 4.5.2.1.4, the total limit of engine operation during each phase of testing shall be recorded in hours by the engine hour meter on the tachometer within  $\pm 2$  percent.

3.4.1.5 Flexible shaft and core assemblies. When tested as specified in 4.5.2.1.5, the flexible shaft and core assemblies shall not exceed  $\pm 2$  mph speedometer pointer oscillation.

### 3.4.2 Resistance to wear.

3.4.2.1 Speedometers and tachometers. After testing as specified in 4.5.3.1 and under the conditions as specified in 4.2.1, the speedometers and tachometers shall meet the previously recorded readings obtained under 3.4.1 within  $\pm 3$  percent.

3.4.2.2 Flexible shaft assembly. When tested as specified in 4.5.3.2, the flexible shaft assembly shall withstand operation for 500 hours without any evidence of failure.

3.4.2.3 Adapters. When tested as specified in 4.5.3.2.2, adapters shall withstand operation for 500 hours without any evidence of failure.

### 3.4.3 Flexible shaft assembly and adapters (operating torque).

3.4.3.1 Flexible shaft assembly. When tested as specified in 4.5.4.1 and under the conditions as specified in 4.2.1, at a temperature of -65 °F, the torque required to rotate the flexible drive shaft core (see 4.2.2) while starting and uniformly accelerating from 0 to 1,000 rpm in 15 seconds shall at no time exceed 80 ounce-force inches (ozf inches) (0.56 newton meters (Nm)).

3.4.3.2 Flexibility (flexible shaft assembly, non-metallic). When tested as specified in 4.5.4.2, the casing of the flexible shaft assembly shall be able to bend 180° in a 10-inch diameter with an applied force of no greater than 8 pounds-force (lbf) (35.6 newtons (N)) .

3.4.3.3 Adapters. When tested as specified in 4.5.4.3 at a temperature of -65 °F, the torque required to rotate adapters of each class while uniformly accelerating from 0 to 1,000 rpm in 15 seconds shall at no time exceed 80 ozf inches (0.56 Nm).



## MIL-DTL-10215L

3.4.3.4 Torsional strength (flexible shaft assembly). When tested as specified in 4.5.4.4, the flexible shaft assembly core shall exhibit a torsional breaking force of not less than 15 lbf inches (1.7 Nm).

3.4.3.4.1 Tensile strength, end fittings. When tested as specified in 4.5.4.4, end fittings attached to the core shall withstand a load of not less than 50 lbs (22.7 kg) applied in tension, without exhibiting any plastic deformation

### 3.5 Environmental.

3.5.1 Lubrication leakage (lubricated flexible shaft assembly only). After the flexible drive shaft assembly is tested in accordance with 4.5.5.1, there shall be no evidence of lubricant leakage. Subsequent to the test, the drive shaft assembly shall meet the requirements of 3.4.3.1.

3.5.2 Vibration resistance. After the speedometers and tachometers are tested in accordance with 4.5.5.2, neither the components nor the assemblies shall show any evidence of disintegration. At the conclusion of the test, the components shall meet the previously recorded reading obtained under 3.4.1 within  $\pm 3$  percent.

3.5.3 Shock resistance. When the speedometers and tachometers are tested in accordance with 4.5.5.3, they shall show no evidence of pointer sticking, no delay of functioning and no disintegration of component materials or assemblies. At the conclusion of the test, the components shall meet the previously recorded reading obtained under 3.4.1 within  $\pm 3$  percent.

3.5.4 Waterproofness, speedometers, tachometers, flexible shaft assemblies and adapters. When the speedometers, tachometers, flexible shaft assemblies and adapters are tested in accordance with the requirements in 4.5.5.4.2 through 4.5.5.4.4, they shall show no evidence of leakage. The saline solution content shall be in accordance with 4.5.5.4.1.

3.5.5 Corrosion resistance. When the speedometers, tachometers, flexible shaft assemblies and adapters are tested in accordance with 4.5.5.5, they shall show no evidence of corrosion affecting operation and shall meet the requirements of 3.4.1.

3.5.6 Fungus resistance. When the speedometers, tachometers, flexible shaft assemblies and adapters are tested as specified in 4.5.5.6, they shall show no evidence of fungus growth affecting operation and shall subsequently meet the applicable requirements of 3.4.1.

3.5.7 Ozone resistance. When the flexible shaft assembly is tested as specified in 4.5.5.7, it shall show no evidence of cracking, rupture or other deterioration.

3.6 Painting. Unless otherwise specified (see 6.2), cleaning, pretreatment, priming and painting shall conform to the appropriate CARC paint system selected from U.S. Army drawing number 12369000. When instrument bezels made of stainless steel are used, they shall be passivated in accordance with ASTM A 380, primer washed in accordance with DOD-P-15328, and finish painted in accordance with MIL-DTL-64159 or MIL-DTL-53039, color Green 383, to a dry film thickness of 1.8 to 3.2 mils. When speedometers and tachometers (figures 8 and 9) are used in the interior of a vehicle or system, they shall be finish painted with an epoxy topcoat in

## MIL-DTL-10215L

accordance with MIL-PRF-22750, colors Green 34094 or 34095, to a dry film thickness of 1.3 to 1.7 mils.

3.7 Identification and marking. Unless otherwise specified (see 6.2), identification and marking of the items shall be in accordance with MIL-STD-130. As a minimum, it shall consist of the manufacturer's CAGE code and the applicable military part number. All markings shall be permanently and legibly printed or stamped on the dial of the speedometers and tachometers, on the casings of the flexible shaft assemblies and on the housing of the adapters. The drive ratio and date of manufacture shall also be marked on the housing of all adapters, and the flexible shaft assembly cores shall be tagged.

3.8 Workmanship. Components shall be free of defects such as rust, burrs and sharp edges that may result in injury of personnel (see 4.5.1). All solder cleaning agents and flux shall be non-corrosive. All traces of flux shall be removed from soldering.

#### 4. VERIFICATION

4.1 Classification of inspections. The inspection requirements specified herein are classified as follows:

- a. Qualification inspection (see 4.3).
- b. Conformance inspection (see 4.4).

4.2 Inspection conditions. Unless otherwise specified (see 6.2), all inspections shall be conducted under the following conditions.

4.2.1 Conditions. Tests shall be conducted under general laboratory conditions acceptable to the Federal Government.

4.2.1.1 Temperatures. Unless otherwise specified herein, tests and temperature tolerances shall be conducted at an ambient temperature of  $77\text{ }^{\circ}\text{F} \pm 15\text{ }^{\circ}\text{F}$  ( $25\text{ }^{\circ}\text{C} \pm 8\text{ }^{\circ}\text{C}$ ), hereafter referred to as simply  $77\text{ }^{\circ}\text{F}$ . If specified, some high temperature tests will be conducted at  $160\text{ }^{\circ}\text{F} \pm 5\text{ }^{\circ}\text{F}$  ( $71\text{ }^{\circ}\text{C} \pm 3\text{ }^{\circ}\text{C}$ ), hereafter referred to as simply  $160\text{ }^{\circ}\text{F}$  while low temperature tests, if specified, will be conducted at  $-65\text{ }^{\circ}\text{F} \pm 5\text{ }^{\circ}\text{F}$  ( $-54\text{ }^{\circ}\text{C} \pm 3\text{ }^{\circ}\text{C}$ ), hereafter referred to as simply  $-65\text{ }^{\circ}\text{F}$ . Unless otherwise specified herein, the test specimen shall be thermally stabilized for 1 hour prior to being tested. Note: these temperature tolerances apply throughout this document.

4.2.1.2 Pressure. Unless otherwise specified herein, all tests shall be conducted at a pressure of  $101.3\text{ kPa} \pm .2\text{ kPa}$ .

4.2.1.3 Humidity. Unless otherwise specified herein, all tests shall be conducted at a humidity level of  $50\% \pm 5\%$

4.2.2 Standard specimens. Unless otherwise specified (see 6.2), and excepting acceptance tests, the shaft assembly shall conform to size no. 05 of figure 1 or size no. 05 of figure 2.

## MIL-DTL-10215L

4.2.3 Apparatus. In addition to the standard measuring equipment, the test apparatus shall include a temperature controlled air chamber, a submersion tank, and a test stand with suitable drives for rotating the drive shaft at controlled speeds.

4.3 Qualification inspection. Qualification inspection (see 3.1) shall include examination of the product (see 4.5.1) and the applicable tests of table III.

TABLE III. Classification of inspections.

Title	Requirement	Inspection	Qualification	Conformance
Performance and calibration:	3.4, 3.4.1	4.5.2, 4.5.2.1		
Speedometers	3.4.1.1	4.5.2.1.1	X	
Odometer	3.4.1.2	4.5.2.1.2	X	
Tachometers	3.4.1.3	4.5.2.1.3	X	
Engine hour meter	3.4.1.4	4.5.2.1.4	X	
Flexible shaft and core assemblies	3.4.1.5	4.5.2.1.5	X	
Resistance to wear:	3.4.2	4.5.3		
Speedometer and tachometer	3.4.2.1	4.5.3.1	X	
Flexible shaft assembly	3.4.2.2	4.5.3.2	X	
Flexible shaft assembly, oscillation	3.3.2.1.1	4.5.3.2.1	X	
Adapters	3.4.2.3	4.5.3.2.2	X	
Operating Torque:	3.4.3	4.5.4		
Flexible shaft assemblies	3.4.3.1	4.5.4.1	X	
Flexibility (non-metallic only)	3.4.3.2	4.5.4.2	X	
Adapters	3.4.3.3	4.5.4.3	X	X
Torsional strength	3.4.3.4	4.5.4.4	X	
Tensile strength	3.4.3.4.1	4.5.4.4	X	X
Environmental:	3.5	4.5.5		
Lubrication leakage	3.5.1	4.5.5.1	X	
Vibration resistance	3.5.2	4.5.5.2	X	
Shock resistance	3.5.3	4.5.5.3	X	
Waterproofness:	3.5.4	4.5.5.4		
Speedometers, tachometers Flexible shaft assembly, and adapters	3.5.4.1	4.5.5.4.2, 4.5.5.4.2.1	X X	X X
Corrosion resistance:	3.5.5	4.5.5.5		
Speedometers, tachometers, flexible Shaft assembly, and adapters		4.5.5.5.1	X	
Fungus resistance:	3.5.6	4.5.5.6		
Speedometers, tachometers, flexible Shaft assembly, and adapters		4.5.5.6.1	X	
Ozone resistance:	3.5.7	4.5.5.7		
Flexible shaft assembly		4.5.5.7.1	X	

## MIL-DTL-10215L

4.3.1 Qualification sample. Qualification sampling shall be in accordance with table IV.

TABLE IV. Qualification sample and sample size.

Sample item	Sample size
Group A speedometers	3
Group B tachometer	3
Class 1 or class 9 shaft assembly, flexible, speedometer and tachometer	4
Class 5 adapter, speedometer and tachometer, 90 degree drive	4
Class 7 adapter, speedometer and tachometer, straight drive	4
Class 8 adapter, coupling/bulkhead, speedometer and tachometer drive	4

4.3.2 Qualification test sequence. The qualification sample selected from table IV shall be tested in accordance with the sequence specified in tables V-A through V-C for the applicable component.

TABLE V-A. Qualification test sequence for speedometers and tachometers.

Specimen	Paragraph	Test
A	4.5.3.1 and table IX	Resistance to wear
	4.5.5.4.2, 4.5.5.4.2.1, 4.5.5.4.4	Waterproofness
	4.5.2.1.1	
B	4.5.2.1.1	
	4.5.5.3	Shock resistance
	4.5.5.6	Fungus resistance
C	4.5.2.1.1	
	4.5.5.2	Vibration resistance
	4.5.5.5	Corrosion resistance

## MIL-DTL-10215L

TABLE V-B. Qualification test sequence for flexible shaft assemblies.

Specimen	Paragraph	Test
A	4.5.5.4.3, 4.5.5.4.4	Waterproofness
	4.5.3.2	Resistance to wear
	4.5.5.5	Corrosion resistance
B	4.5.5.1	Lubrication leakage
	4.5.4.1	Operating torque
C	4.5.4.2	Flexibility (non-
	4.5.3.2.1	Oscillation
	4.5.5.6	Fungus resistance
D	4.5.4.4	Torsional strength
	4.5.5.7	Ozone resistance

TABLE V-C. Qualification test sequence for adapters.

Specimen	Paragraph	Test
A	4.5.3.2.2	Resistance to wear
	4.5.5.4.3, 4.5.5.4.4	Waterproofness
B	4.5.5.5	Corrosion resistance
C	4.5.5.6	Fungus resistance
D	4.5.4.3	Operating torque

4.3.3 Maintenance of qualification. At specified intervals determined by the qualifying activity, the manufacturer must be able to demonstrate the company still has the capabilities and facilities necessary to produce the QPL items in accordance with this specification and in accordance with the provisions governing qualification in SD-6.

4.4 Conformance inspections. Conformance inspection shall include the examination of the product (see 4.5.1) and the applicable tests of table III.

## MIL-DTL-10215L

4.4.1 Sampling plan. Unless otherwise specified (see 6.2), the sampling plan for conformance inspection examination and tests shall be random selection from the inspection lot in accordance with table VI.

TABLE VI. Sampling plan for conformance inspection.

Inspection lot size	Sample size examination		
	Major	Minor	Test
2 to 8	*	5	5
9 to 15	13	5	5
16 to 25	13	5	5
26 to 50	13	5	5
51 to 90	13	7	7
91 to 150	13	11	11
151 to 280	20	13	13
281 to 500	29	16	16
501 to 1,200	34	19	19
1,201 to 3,200	42	23	23
3,201 to 10,000	50	29	29
10,001 to 35,000	60	35	35
35,001 to 150,000	74	40	40
150,001 to 500,000	90	40	40
500,001 and over	102	40	40

\*Indicates 100 percent of lot must be inspected.

4.4.1.1 Lot formation. An inspection lot shall consist of all speedometers, tachometers, and flexible shaft assemblies of a single type, group, class and part identification number (PIN), from an identifiable production period, from one manufacturing location submitted at the same time for acceptance.

## MIL-DTL-10215L

4.5 Methods of inspection.

4.5.1 Examination of product. Instruments and components shall be examined for the defects listed in table VII. Examination shall be visual, tactile or by measurement with standard inspection equipment.

TABLE VII. Classification of defects.

Defect	Method of examination	Category	
		Major	Minor
Design, materials and construction affecting interchangeability (see 3.3)	Standard inspection equipment and functional	101	
Design, materials and construction not affecting interchangeability (see 3.3)	Standard inspection equipment and functional		201
Painting not as specified (see 3.6)	Visual		202
Identification and marking not as specified (see 3.7)	Visual		203
Workmanship (see 3.8)	Visual		204

4.5.2 Performance.4.5.2.1 Calibration.

4.5.2.1.1 Speedometers. To determine conformance to 3.4.1.1, the speedometers and tachometers shall be mounted in an air chamber with the dial face tilted 10 degrees backward from the vertical while connected to a flexible shaft assembly, The air chamber shall be maintained at each of the following temperatures for 4 hours: 77 °F and 160 °F. After each 4-hour period and while still maintaining the temperature, the drive shaft shall be rotated at 167 rpm, 500 rpm, and 1,000 rpm, and the pointer indications shall be compared to the limits as set forth in table II.

4.5.2.1.2 Odometer. To determine conformance to 3.4.1.2, rotation of the drive shaft shall be continued for 6 hours at a speed of 1,000 rpm at 77 °F at the conclusion of the test specified in 4.5.2.1.1. The odometer-indicated mileage for the 6-hour period shall be compared with the correct mileage.

4.5.2.1.3 Tachometers. To determine conformance to 3.4.1.3, tachometers shall be tested as specified in 4.5.2.1.1, except that the drive shaft shall be rotated at 250 rpm, 1,000 rpm, and 1,500 rpm.

## MIL-DTL-10215L

4.5.2.1.4 Engine hour meter. To determine conformance to 3.4.1.4, the drive shaft shall be rotated at one of the optional speeds and for the time length specified in table VIII at the conclusion of the test specified in 4.5.2.1.3. During and after the test, the engine hour meter reading shall be observed.

TABLE VIII. Tachometer hour meter optional test speeds.

Tachometer type	rpm	Time
I	1,000	6 hours, 9.6 minutes
I	1,026	6 hours

4.5.2.1.5 Flexible shaft and core assemblies. To determine conformance to 3.4.1.5, the flexible shaft and core assemblies shall be connected to a previously calibrated speedometer and shall be rotated to indicate 35 mph for a period of 10 minutes. The speedometer shall be observed for any deviations from the requirements of 3.4.1.5.

4.5.3 Resistance to wear.

4.5.3.1 Speedometers and tachometers. To determine conformance to 3.4.2.1, the speedometers and tachometers shall be operated for 1,000 hours at the speeds and temperatures specified in table IX. At the conclusion of the 1,000-hour test period, the speedometers and tachometers shall be subjected to the applicable calibration test specified in 4.5.2.1 at 77 °F.

TABLE IX. Speedometer and tachometer wear test.

Hours	Temperature	Speed
750	77 °F	Equal indicating periods for 1/3, 2/3 and full scale readings
250	160 °F	(Same as above)

4.5.3.2 Flexible shaft assembly. To determine conformance to 3.4.2.2, a flexible shaft assembly 10 feet (3.05 meters (m)) long shall be mounted in a test fixture in such a manner that the shaft is confined in a S-shape having two bends of 180 degrees in the same plane, with each bend having a 5-inch (12.7-centimeter (cm)) radius. With a constant load of  $22 \pm 2$  ozf inches, ( $0.16 \pm 0.01$  Nm) at the speedometer and tachometer end of the shaft core, the core shall be operated at the speeds, temperatures, and times specified in table X.

TABLE X. Flexible shaft assembly and adapter wear test.

Hours	Temperature	Speed (rpm)
100	77 °F	750
100	77 °F	1,250
200	77 °F	2,000
25	160 °F	750
25	160 °F	1,250
50	160 °F	2,000



## MIL-DTL-10215L

4.5.3.2.1 Flexible shaft assembly, oscillation. To determine conformance to 3.3.2.1.1, a flexible shaft assembly 10 feet (3.05 m) long shall be connected to a previously calibrated speedometer and shall be rotated at indicated speedometer speeds from 10 to 60 mph at 10 mph intervals or 20 to 100 km/h at 20 km/h intervals. Running time at each speed shall then be repeated with a previously calibrated tachometer. The indicated tachometer rpm shall be between 500 and 4,000 at 500 rpm intervals with a running time of 10 minutes at each rotating speed.

4.5.3.2.2 Adapter. To determine conformance to 3.4.2.3, the adapter shall be mounted in a fixture with a constant load of  $22 \pm 2$  ozf inches ( $0.16 \pm 0.01$  Nm) and operated at the speeds, temperatures and times specified in table X.

#### 4.5.4 Operating torque.

4.5.4.1 Flexible shaft assemblies. To determine conformance to 3.4.3.1, the flexible shaft assembly (see 4.2.2) shall be placed in a test fixture with the test sample temperature and air temperature maintained constant at  $-65$  °F for 7 hours. At the conclusion of the 7-hour period and while still at the above specified temperature, the core shall be rotated without load. The torque required to rotate the core in starting and accelerating shall be measured.

4.5.4.2 Flexibility (non-metallic only). To determine conformance to 3.4.3.2, a section of flexible shaft assembly approximately 17 inches (43 cm) from one end shall be bent 180 degrees around a 10-inch (25.4-cm) diameter mandrel in an ambient air temperature of 77 °F. A spring scale or other suitable measuring device shall be used at the fitting end to record the maximum force required.

4.5.4.3 Adapters. To determine conformance to 3.4.3.3, the adapter shall be placed in a test fixture with the test sample temperature and air temperature maintained constant at  $-65$  °F for 7 hours. At the conclusion of the 7-hour period and while still held at the above specified temperature, the core shall be rotated without load. The torque required to rotate the core in starting and accelerating shall be measured.

4.5.4.4 Torsional strength (flexible shaft assembly). To determine compliance to 3.4.3.4, the flexible shaft assembly core shall be placed in a torsion-testing machine in a straight position without slack so that 10 inches (25.4 cm) of the speedometer and tachometer end of the core will be subjected to torsion. The core shall be twisted in a clockwise direction. The test shall be repeated with the drive end of the core in the machine. The core end fittings shall then be subjected to a load applied in tension to the core with the fittings anchored to determine conformance to 3.4.3.4.1.

#### 4.5.5 Environmental.

4.5.5.1 Lubrication leakage (lubricated flexible shaft assembly only). To determine conformance to 3.5.1, the flexible shaft assembly shall be carefully sealed at both ends. Oil, grease, and dirt should be removed by degreasing the assembly and sealed ends with a solvent cleaner and scrubbing and then thoroughly drying. The flexible shaft shall then be placed in a temperature controlled air chamber at a constantly maintained temperature of  $250$  °F  $\pm$   $5$  °F ( $121$  °C  $\pm$   $3$  °C) for 2 hours. At the conclusion of the 2-hour period, the assembly shall be

## MIL-DTL-10215L

removed from the air chamber and suspended from the transmission end in a vertical position. The lower end of the flexible shaft assembly shall be wiped over the entire area with a good quality, absorbent tissue. Then the tissue shall be visually inspected; no evidence of absorbed lubricant shall be allowed. Subsequently, the flexible shaft assembly shall be subjected to the test specified in 4.5.4.1 to determine conformance to 3.4.3.1.

4.5.5.2 Vibration resistance. To determine conformance to 3.5.2, the speedometer and tachometer shall be mounted as if in operation and subjected to the vibration test as specified in MIL-STD-202, method 201, except that motion shall be applied for 1 hour in each direction of the three major axes. During vibration, the speedometer and tachometer shall be operated in such a manner that the speedometer and tachometer pointer shall be at midscale, and observation shall be made for oscillation. At the conclusion of the test, the speedometer and tachometer shall be subjected to the applicable performance tests specified in 4.5.2.1 at 77 °F.

4.5.5.3 Shock resistance. To determine conformance to 3.5.3, the speedometer and tachometer shall be mounted as if in operation and subjected to the shock (specified pulse) test as specified in MIL-STD-202, method 213, test condition I (using the sawtooth waveform). The test shall be repeated 10 times and applied in the vertical axis. During shock, the speedometer and tachometer shall be operated in such a manner that the speedometer and tachometer pointer shall be at midscale, and observation shall be made for oscillation. At the conclusion of the test, the speedometer and tachometer shall be subjected to the applicable performance tests specified in 4.5.2.1 at 77 °F.

4.5.5.4 Waterproofness.

4.5.5.4.1 Saline solution. The salt used shall be sodium chloride containing on a dry basis not more than 0.1 percent of sodium iodide and not more than 0.2 percent of total impurities. The solution shall be prepared by dissolving 5 parts by weight of salt in 95 parts by weight of distilled water. The solution shall be kept free of sediment by filtration or decantation when used in the waterproofness tests specified in 3.5.4.

4.5.5.4.2 Vacuum test for speedometers and tachometers. To determine conformance to 3.5.4, the speedometers and tachometers shall be subjected to a vacuum test. The test chamber shall be evacuated to a pressure 6 pounds below atmospheric to create a minimum of 6 psi (0.42 kg/cm<sup>2</sup>) of internal pressure to all voids within the component while totally immersed in the saline solution for 30 minutes during qualification testing and 5 minutes during conformance testing. The component shall be operated and carefully observed for air bubbles from the interior of the device during the specified time period. Bubbles that are the result of entrapped air on the various exterior surfaces of the device shall not be considered a leak. The speedometer and tachometer connectors shall be sealed with caps simulating the mating flexible cable connectors or as otherwise specified. The flexible shaft assemblies and adapters shall be sealed against leakage.

4.5.5.4.2.1 Pressure test for speedometers and tachometers. Following the first test in 4.5.5.4.2, the speedometers and tachometers shall be subjected to a pressure test. The test chamber shall then be pressurized to 6 pounds above atmospheric to create a minimum of 6 psi (0.42 kg/cm<sup>2</sup>) of internal pressure to all voids within the component while totally immersed in the saline solution for 30 minutes during qualification testing and 5 minutes during conformance testing. The

## MIL-DTL-10215L

component shall be operated and carefully observed for air bubbles from the interior of the device during the specified time period. Bubbles that are the result of entrapped air on the various exterior surfaces of the device shall not be considered a leak. The speedometer and tachometer connectors shall be sealed with caps simulating the mating flexible cable connectors. Test results obtained shall be compared with the data from the vacuum test in 4.5.5.4.2.

4.5.5.4.3 Internal pressure test for flexible shaft assemblies, and adapters. To determine conformance to 3.5.4, the flexible shaft assemblies and adapters shall be subjected to an internal pressure test of 6 psi (0.42 kg/cm<sup>2</sup>) while totally immersed in tap water for 30 minutes during qualification testing and 5 minutes during conformance testing. The component shall be operated and carefully observed for air bubbles from the interior of the device during the specified time period. Bubbles that are the result of entrapped air on the various exterior surfaces of the device shall not be considered a leak. The flexible shaft assemblies and adapters shall be sealed against leakage.

4.5.5.4.4 Speedometers, tachometers, flexible shaft assemblies, and adapters (post inspection). Following the application of the external and internal pressure tests, the components shall be disassembled and inspected for the presence of water. If water is present, the component shall be rejected. If the component is dry, it shall be reassembled and subjected to 15 hours of dry operation (three 5-hour periods) at full rated output. Damage that would impair mechanical operation of the component shall be considered evidence of failure.

4.5.5.5 Corrosion resistance.

4.5.5.5.1 Speedometers, tachometers, flexible shaft and core assemblies, and adapters. To determine compliance to 3.5.5, the speedometers, tachometers, flexible shaft and core assemblies, and adapters shall be subjected to the corrosion resistance test specified in ASTM B 117 for 200 hours. At the conclusion of the 200-hour period, the speedometer and tachometer shall be subjected to the applicable test specified in 4.5.2.1. The speedometer and tachometer and both ends of the flexible shaft assemblies and adapters shall be sealed against leakage with connectors simulating the applicable mating parts or as otherwise specified.

4.5.5.6 Fungus resistance.

4.5.5.6.1 Speedometers, tachometers, flexible shaft and core assemblies, and adapters. To determine conformance to 3.5.6, the speedometers, tachometers, flexible shaft and core assemblies, and adapters shall be tested as specified in ASTM G 21. After the tests, the speedometers, tachometers, flexible shaft and core assemblies, and adapters shall be subjected to the applicable test specified in 4.5.2.1. The speedometer and tachometer and both ends of the flexible shaft assemblies and adapters shall be sealed against leakage with connectors simulating the applicable mating parts or as otherwise specified.

4.5.5.7 Ozone resistance.

4.5.5.7.1 Flexible shaft assembly. To determine conformance to 3.5.7, the flexible shaft assembly shall be conditioned at ambient room temperature for 45 minutes. The flexible shaft assembly shall then be placed in a test exposure chamber containing air mixed with ozone in the

## MIL-DTL-10215L

proportion of  $50 \pm 5$  parts per 100 million parts of atmospheric air by volume for 168 hours at a temperature of  $100 \text{ }^\circ\text{F} \pm 5 \text{ }^\circ\text{F}$  ( $38 \text{ }^\circ\text{C} \pm 3 \text{ }^\circ\text{C}$ ). Immediately after the completion of the test period, each sample shall be examined for evidence of cracking using 7X magnification, with the specimen coiled in a 12-inch (30-cm) inside diameter loop.

## 5. PACKAGING

5.1 Packaging. For acquisition purposes, the packaging requirements shall be as specified in the contract or order (see 6.2). When packaging of materiel is to be performed by DoD or in-house contractor personnel, these personnel need to contact the responsible packaging activity to ascertain packaging requirements. Packaging requirements are maintained by the Inventory Control Point's packaging activities within the Military Service or Defense Agency, or within the military service's system commands. Packaging data retrieval is available from the managing Military Department's or Defense Agency's automated packaging files, CD-ROM products, or by contacting the responsible packaging activity..

## 6. NOTES

(This section contains information of a general or explanatory nature that may be helpful, but is not mandatory.)

6.1 Intended use. The speedometers, tachometers, flexible shaft assemblies, flexible shaft assembly cores and adapters covered by this specification are intended for use in indicating speed in miles per hour or engine speed in revolutions per minute, and to record total distance in miles traveled by the vehicle or total hours of operation of the engine.

6.1.1 Military unique. The speedometers, tachometers, and related parts covered by this specification are intended for use in military motor vehicles. These devices may be subjected to severe conditions including vibration, shock, saltwater submersion, and temperature extremes.

6.2 Acquisition requirements. Acquisition documents should specify the following:

- a. Title, number and date of this specification.
- b. Group (see 1.2.2), class (see 1.2.3) and quantity required.
- c. Painting, if other than as specified (see 3.6).
- d. Identification and marking, if other than as specified (see 3.7).
- e. Inspection conditions, if other than specified (see 4.2).
- f. Standard specimens, if other than specified (see 4.2.2).
- g. Sampling plan, if other than specified (see 4.4.1).
- h. Packaging requirements (see 5.1).

6.3 Qualification. With respect to products requiring qualification, awards will be made only for products which are, at the time of award of contract, qualified for inclusion in QPL-10215 whether or not such products have actually been listed by that date. The attention of the contractors is called to these requirements, and manufacturers are urged to arrange to have the products that they propose to offer to the Federal Government tested for qualification in order that they may be eligible to be awarded contracts or orders for the products covered by this specification.

## MIL-DTL-10215L

Information pertaining to qualification of products may be obtained from Defense Supply Center Richmond, Attn: DSCR-VEB, 8000 Jefferson Davis Highway, Richmond, VA 23297-5616 or via email at [STDZNMGT@dla.mil](mailto:STDZNMGT@dla.mil).

6.4 Subject term (key word) listing.

distributor  
engine  
mechanical  
vehicle

6.5 Changes from the previous issue. The margins of this specification are marked with vertical lines to indicate where changes from the previous issue were made. This was done as a convenience only, and the Government assumes no liability whatsoever for any inaccuracies in these notations. Bidders and contractors are cautioned to evaluate the requirements of this document based on the entire content irrespective of the marginal notations and relationship to the last previous issue.

6.6 Supersession. This specification supersedes the documents listed in table XI.

Table XI. Supersession data.

Document	Date
MIL-PRF-10215J	16 January 2001
MIL-S-10215H	4 November 1992
MS35916D	11 July 1991
MS39021F	11 July 1991
MS39130D	14 November 1985
MS39132G	27 January 1988
MS51071H	12 August 1987
MS51072F	4 August 1987
MS52116A	19 January 1988
DS52140	28 September 1977
MS53099A	24 June 1970

## MIL-DTL-10215L

6.7 Cross-reference data. Instruments and components conforming to this specification are interchangeable/substitutable with instruments and components conforming to the documents listed in table XII.

Table XII. Cross-reference data.

Document	Date	MIL-DTL-10215K	MIL-DTL-10215L
MIL-PRF-10215J	16 January 2001	N/A	N/A
MIL-S-10215H	4 November 1992	N/A	N/A
MS35916D	11 July 1991	Figure 10	Figure 9
MS39021F	11 July 1991	Figure 8	Figure 8
MS39130D	14 November 1985	Figure 5	Figure 5
MS39132G	27 January 1988	Figure 6	Figure 6
MS51071H	12 August 1987	Figure 1	Figure 1
MS51072F	4 August 1987	Figure 4	Figure 4
MS52116A	19 January 1988	Figures 2 and 3	Figures 2 and 3
DS52140	28 September 1977	Figure 9	Deleted
MS53099A	24 June 1970	Figure 7	Figure 7

6.8 Cross-reference classification data. Table XIII displays the revised classification data between MIL-PRF-10215J and MIL-DTL-10215L.

Table XIII. Cross-reference classification data.

MIL-PRF-10215J	MIL-DTL-10215K	MIL-DTL-10215L
Type I	Type I	Type I
Type II	Deleted	Deleted
Group A	Group A - Speedometer (0-60 miles per hour), fixed mounting	Group A - Speedometer (0-60 miles per hour), fixed mounting
Group B	Group B - Tachometer, fixed mounting	Group B - Tachometer, fixed mounting
Group C	Deleted	Deleted
Group D	Deleted	Deleted
	Group E - Speedometer (0-100 k/hr), fixed mounting	Deleted
	Group F - Flexible shaft assemblies, flexible shaft core assemblies and adapters	Group F - Flexible shaft assemblies, flexible shaft core assemblies and adapters
Class 1	Class 1	Class 1
Class 2	Deleted	Deleted
Class 3	Deleted	Deleted
Class 4	Class 4	Class 4
Class 5	Class 5	Class 5
Class 7	Class 7	Class 7
Class 8	Class 8	Class 8
Class 9	Class 9	Class 9

## MIL-DTL-10215L

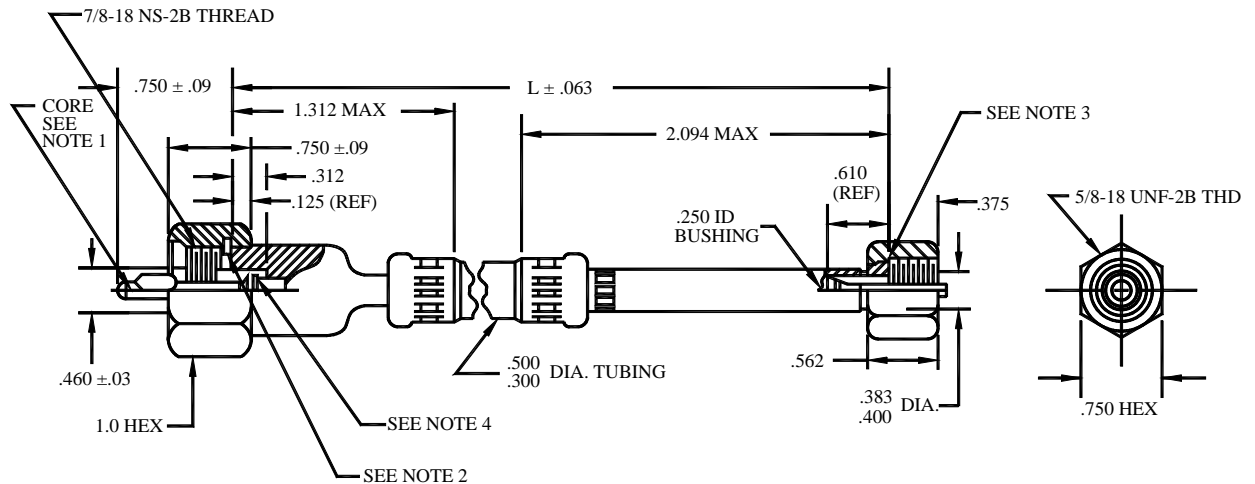

Dimensions are in inches.

Unless otherwise specified, tolerances are  $\pm 1/64$  for fractional values and  $\pm 0.010$  for decimal values.

Size no.	Former MS part no.	Former Army part no.	Shaft length
01	MS 51071-1	8735736	17.5
02	MS 51071-2	7976738	22.5
03	MS 51071-3	7983060	40
04	MS 51071-4	7527480	55
05	MS 51071-5	7320561	62.5
07	MS 51071-7	7064526	67.5
08	MS 51071-8	7415912	72.5
09	MS 51071-9	7096559	77.5
10	MS 51071-10	7526039	85
11	MS 51071-11	7412913	90
12	MS 51071-12	7983059	95
13	MS 51071-13	7527479	100
14	MS 51071-14	7983213	107.5
15	MS 51071-15	7983057	144
16	MS 51071-16	7954735	156
17	MS 51071-17	7987478	168
18	MS 51071-18	8340482	216
19	MS 51071-19	7344191	120
20	MS 51071-20	8345795	138
21	MS 51071-21	-----	13

## NOTES:

1. For core assembly details and associated core assemblies, see figure 4.
2. For gasket material and dimensions, see former Army part number 7539688.
3. For gasket material and dimensions, see former Army part number 7539689.
4. For washer material and dimensions, see former Army part number 5329467.
5. Tubing shall be metal covered with rubber or plastic to meet performance requirements of procurement specification.

FIGURE 1. Shaft assembly, flexible metallic, tachometer and speedometer.

## MIL-DTL-10215L

PREFERRED CONSTRUCTION  
(See FIGURE 3 for optional construction)

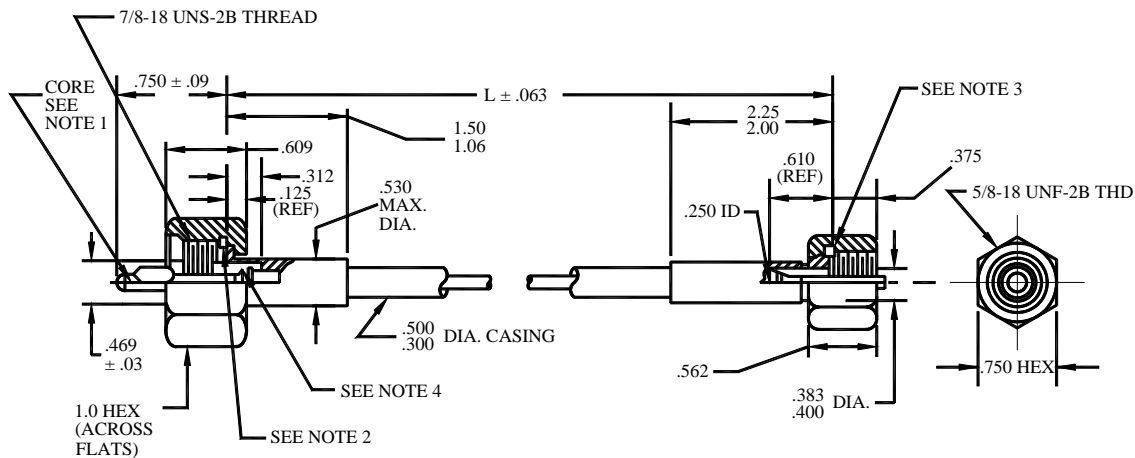

Dimensions are in inches.

Unless otherwise specified, tolerances are  $\pm 1/64$  for fractional values and  $\pm 0.010$  for decimal values.

Size no.	Former MS part no.	Shaft length
01	MS 52116-1	17.5
02	MS 52116-2	22.5
03	MS 52116-3	40
04	MS 52116-4	55
05	MS 52116-5	62.5
07	MS 52116-7	67.5
08	MS 52116-8	72.5
09	MS 52116-9	77.5
10	MS 52116-10	85
11	MS 52116-11	90
12	MS 52116-12	95
13	MS 52116-13	100
14	MS 52116-14	107.5
15	MS 52116-15	144
16	MS 52116-16	156
17	MS 52116-17	168
18	MS 52116-18	216
19	MS 52116-19	120
20	MS 52116-20	138

NOTES:

1. For core assembly details and associated core assemblies, see figure 4.
2. For gasket material and dimensions, see former Army part number 7539688.
3. For gasket material and dimensions, see former Army part number 7539689.
4. For washer material and dimensions, see former Army part number 5329467.
5. Tubing shall be metal covered with rubber or plastic to meet performance requirements of procurement specification.

FIGURE 2. Shaft assembly, flexible, plastic, tachometer and speedometer.



## MIL-DTL-10215L

OPTIONAL CONSTRUCTION  
(See FIGURE 2 for preferred construction)

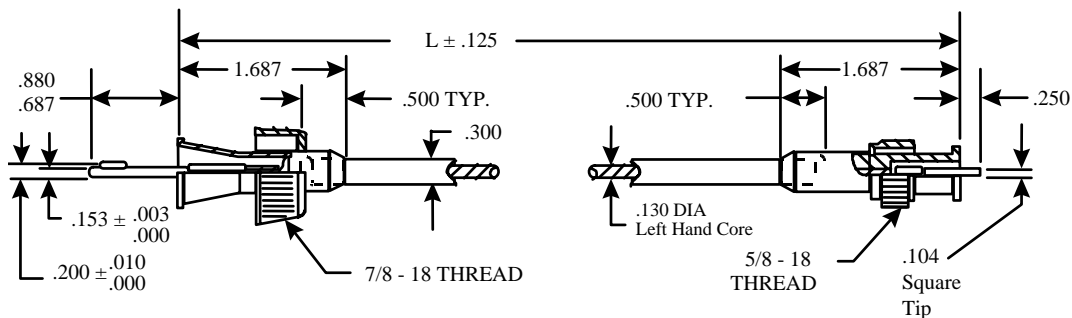

Dimensions are in inches.

Unless otherwise specified, tolerances are  $\pm 1/64$  for fractional values and  $\pm 0.010$  for decimal values.

Size no.	Former MS part no.	Shaft length
21	MS 52116-21	72
22	MS 52116-22	84
23	MS 52116-23	96
24	MS 52116-24	108
25	MS 52116-25	120
26	MS 52116-26	132
27	MS 52116-27	144
28	MS 52116-28	156
29	MS 52116-29	168
30	MS 52116-30	180
31	MS 52116-31	192
32	MS 52116-32	204
33	MS 52116-33	216
34	MS 52116-34	228
35	MS 52116-35	240
36	MS 52116-36	252
37	MS 52116-37	264
38	MS 52116-38	276
39	MS 52116-39	288
40	MS 52116-40	300

FIGURE 3. Shaft assembly, flexible, plastic, tachometer and speedometer - optional construction.

## MIL-DTL-10215L

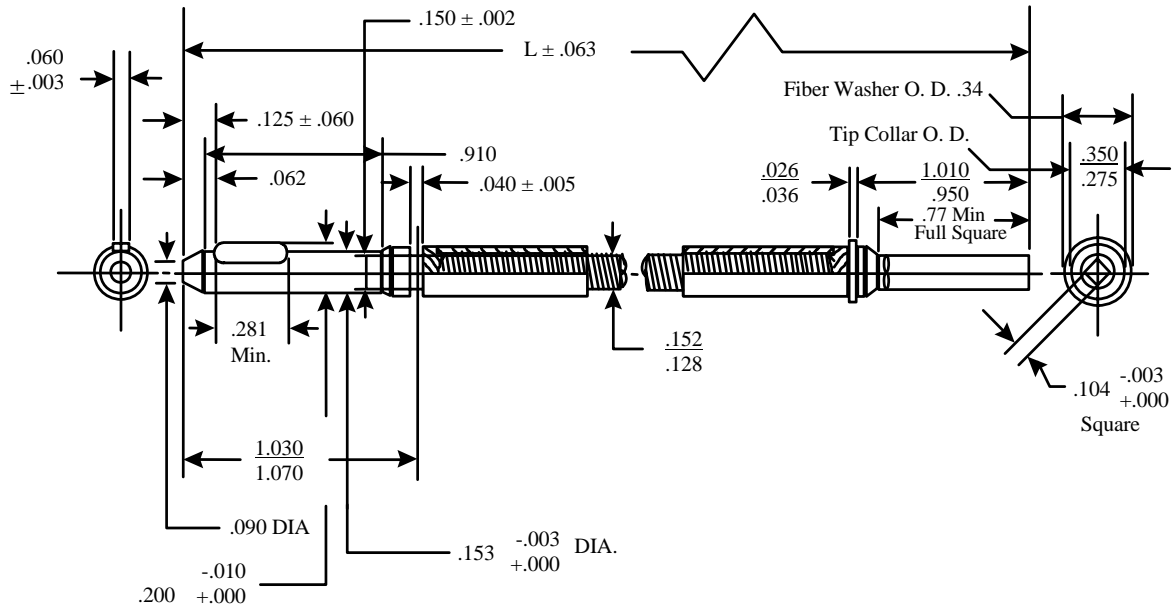

Dimensions are in inches.

Unless otherwise specified, tolerances are  $\pm 1/64$  for fractional values and  $\pm 0.010$  for decimal values.

Size no.	Former MS part no.	Former Army part no.	Core length
01	MS 51072-1	8749985	18.7
02	MS 51072-2	7976737	23.7
03	MS 51072-3	7418497	41.2
04	MS 51072-4	7527483	56.2
05	MS 51072-5	7064607	63.7
07	MS 51072-7	7064520	68.7
08	MS 51072-8	7418498	73.7
09	MS 51072-9	7418491	78.7
10	MS 51072-10	7527481	86.2
11	MS 51072-11	7415830	91.2
12	MS 51072-12	7418490	96.2
13	MS 51072-13	7527482	101.2
14	MS 51072-14	7984852	108.7
15	MS 51072-15	7984853	145.2
16	MS 51072-16	7064524	157.2
17	MS 51072-17	8366051	169.2
18	MS 51072-18	8741685	217.2
19	MS 51072-19	7355827	121.2
20	MS 51072-20	8345796	139.2
21	MS 51072-21		14.2

NOTE: For associated shaft assemblies see figure 1. Outer layer of core wire shall be wound in the direction of right hand lay.

FIGURE 4. Core, flexible shaft assembly, tachometer and speedometer.

MIL-DTL-10215L

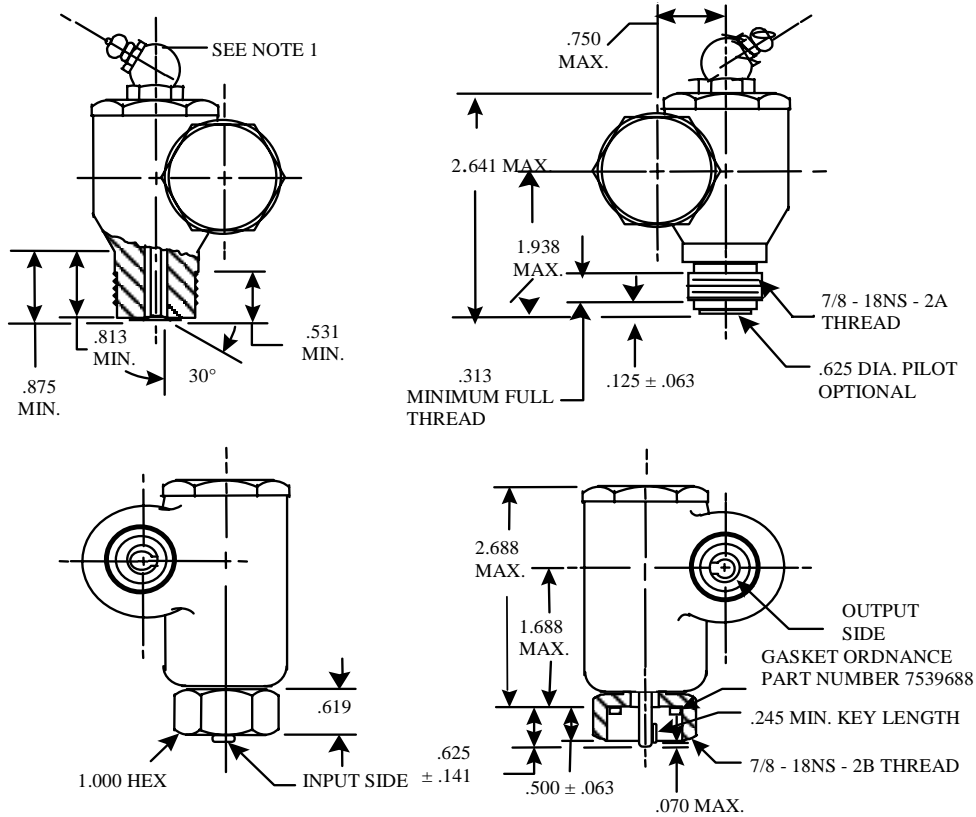

LEFT HAND HOUSING

RIGHT HAND HOUSING

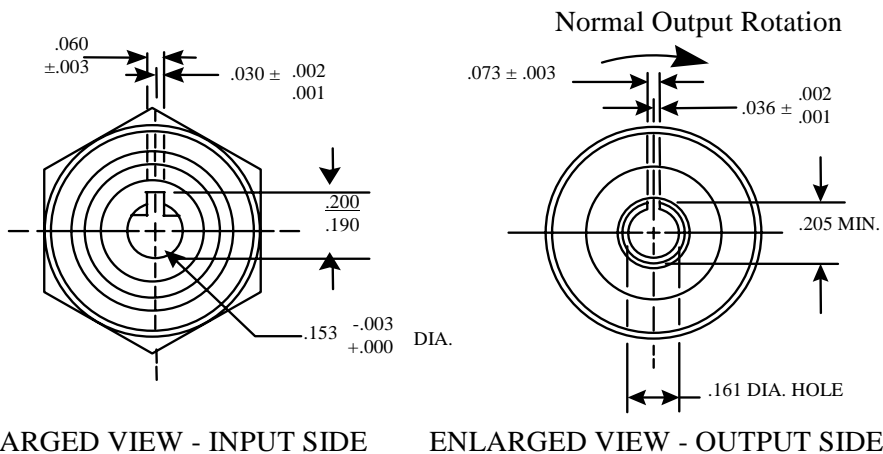

Dimensions are in inches.

Unless otherwise specified, tolerances are ±1/64 for fractional values and ±0.010 for decimal values.

NOTE: Lubricate with grease conforming to MIL-PRF-23827. Sealed lubrication or lubrication fittings are optional.

FIGURE 5. Adapter, speedometer and tachometer, 90 degree drive.

## MIL-DTL-10215L

Size no.	Former MS part no.	Former Army part no.	RPM ratio output/input	Input shaft rotation when output shaft is rotated clockwise <sup>1,2</sup>	Housing type
01	MS 39130-1		0.158	Clockwise	right hand
02	MS 39130-2		0.166	counter-clockwise	right hand
03	MS 39130-3	7372726	0.200	Clockwise	right hand
04	MS 39130-4		0.200	counter-clockwise	right hand
05	MS 39130-5	10900477	0.210	Clockwise	left hand
06	MS 39130-6	10917230	0.222	Clockwise	right hand
07	MS 39130-7		0.250	Clockwise	right hand
08	MS 39130-8		0.250	counter-clockwise	right hand
09	MS 39130-9		0.300	Clockwise	right hand
10	MS 39130-10		0.300	counter-clockwise	right hand
11	MS 39130-11	10900443	0.364	Clockwise	right hand
12	MS 39130-12	10921625	0.364	counter-clockwise	right hand
13	MS 39130-13		0.416	Clockwise	right hand
14	MS 39130-14		0.421	counter-clockwise	right hand
15	MS 39130-15	8340483	0.500	Clockwise	right hand
16	MS 39130-16		0.500	counter-clockwise	right hand
17	MS 39130-17	6228369	0.500	Clockwise	left hand
18	MS 39130-18	6228367	0.500	counter-clockwise	left hand
19	MS 39130-19		0.611	Clockwise	right hand
20	MS 39130-20		0.611	counter-clockwise	right hand
21	MS 39130-21		0.705	Clockwise	right hand
22	MS 39130-22		0.714	counter-clockwise	right hand
23	MS 39130-23		0.833	counter-clockwise	right hand
24	MS 39130-24		0.909	Clockwise	right hand
25	MS 39130-25	7983058	1.000	Clockwise	right hand
26	MS 39130-26		1.000	counter-clockwise	right hand
27	MS 39130-27	7987721	1.000	Clockwise	left hand
28	MS 39130-28	6209787	1.000	counter-clockwise	left hand
29	MS 39130-29		1.100	Clockwise	right hand
30	MS 39130-30		1.100	counter-clockwise	right hand

<sup>1</sup>Shaft rotation is determined when looking into the input or output connector.

<sup>2</sup>Previous revisions of this table referred to the input shaft rotation with respect to output side as "same" (counter-clockwise) and "reverse" (clockwise).

FIGURE 5. Adapter, speedometer and tachometer, 90 degree drive - Continued.

## MIL-DTL-10215L

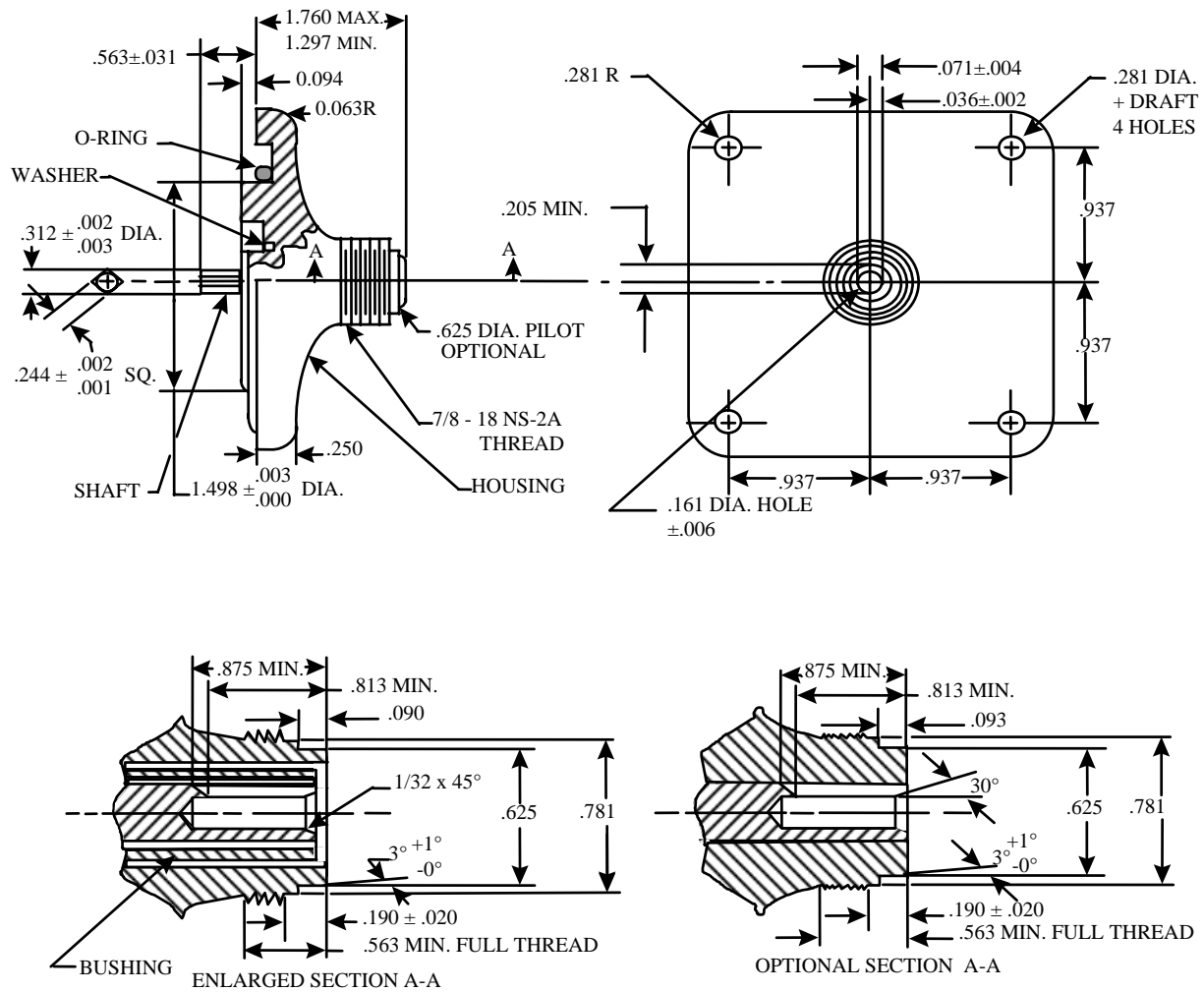

Dimensions are in inches.

Unless otherwise specified, tolerances are  $\pm 1/64$  for fractional values and  $\pm 0.010$  for decimal values.

FIGURE 6. Adapter, speedometer and tachometer, straight drive.

MIL-DTL-10215L

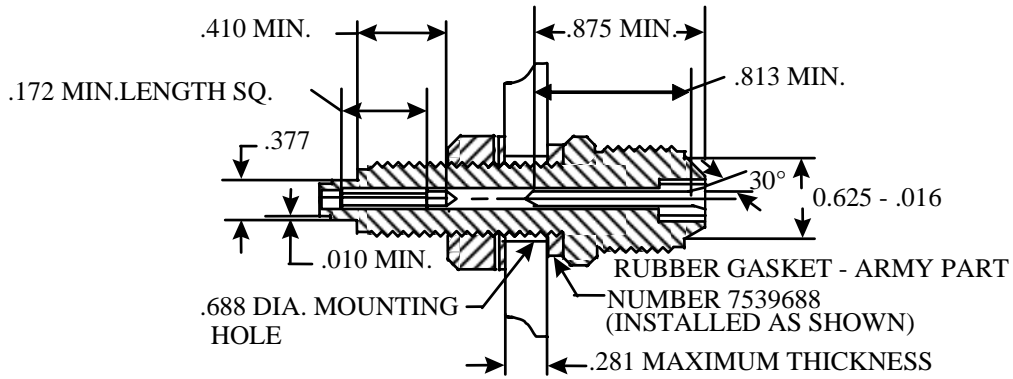
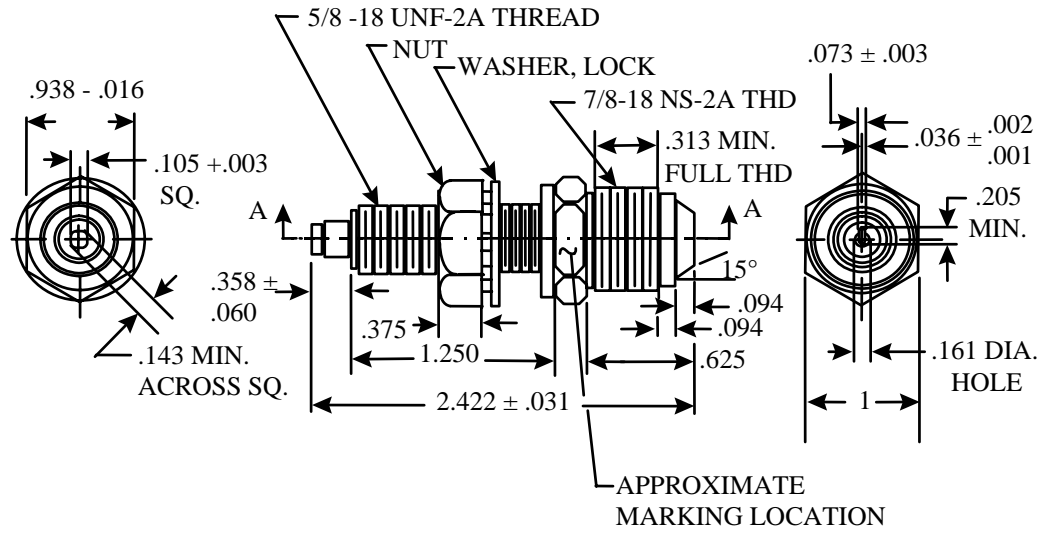

SECTION A-A

Dimensions are in inches.

Unless otherwise specified, tolerances are ±1/64 for fractional values and ±0.010 for decimal values.

Size no.	Former MS part no.	Former Army part no.	Description	Application
01	MS 53099-1	7983056	Without rubber gasket	Non-waterproof
02	MS 53099-2	None	With rubber gasket	Waterproof

FIGURE 7. Adapter, coupling/bulkhead, tachometer and speedometer drive.

MIL-DTL-10215L

FIGURE 8. Speedometer, (0-60 mph).

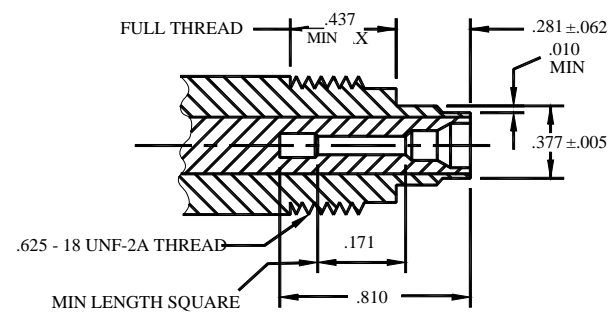
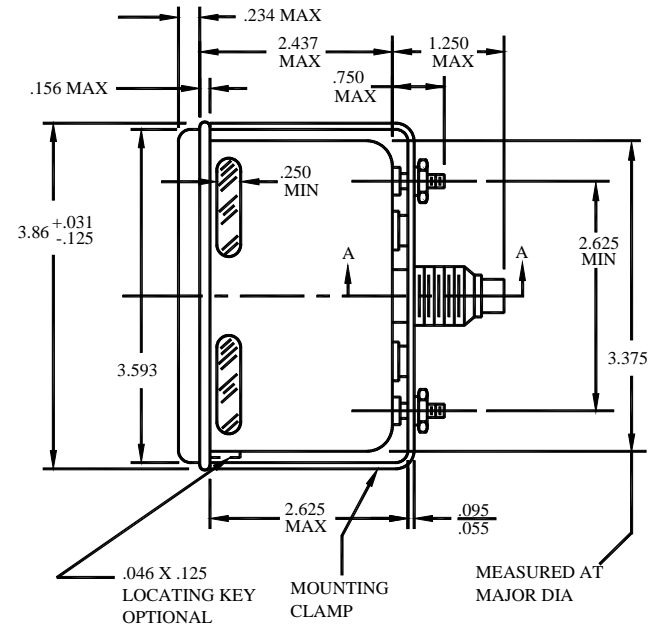
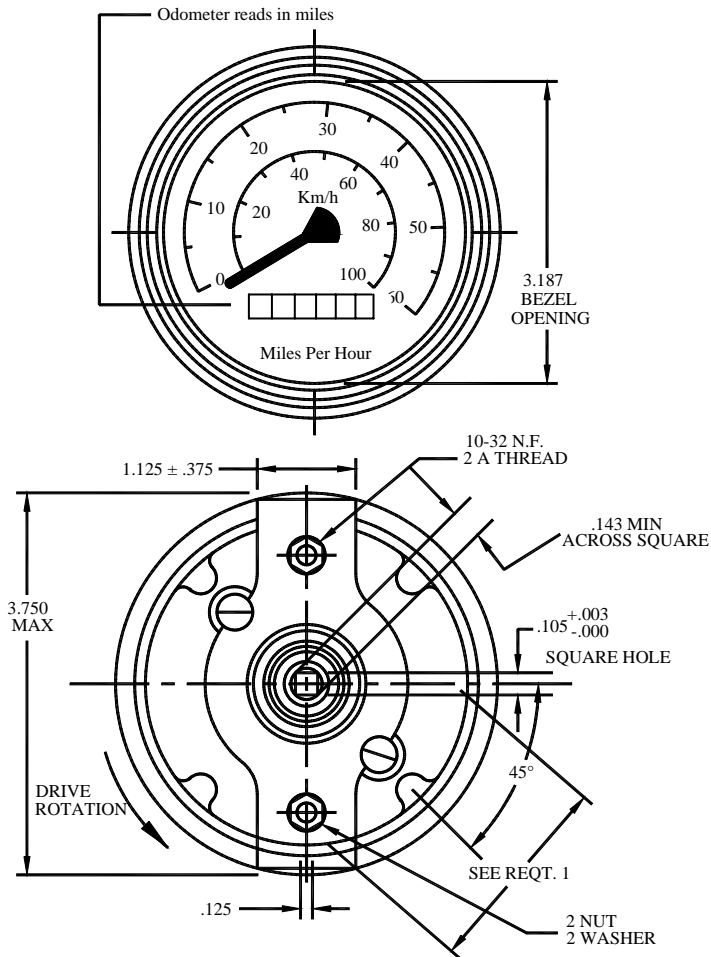

SECTION A-A  
INSTRUMENT CONNECTION

REQUIREMENTS: 1. FOUR (4) ILLUMINATING WINDOWS SHALL BE 1.86 MIN. CHORDAL LENGTH, EQUALLY SPACED 45° OFF HORIZONTAL CENTERLINE.  
OPTIONAL CONSTRUCTION: 360° ILLUMINATING WINDOW.

NOTE: UNLESS OTHERWISE SPECIFIED, DIMENSIONS ARE IN INCHES, TOLERANCES ARE ±.015 ON DECIMALS, ±1° ON ANGULAR DIMENSIONS.

[D1]

MIL-DTL-10215L

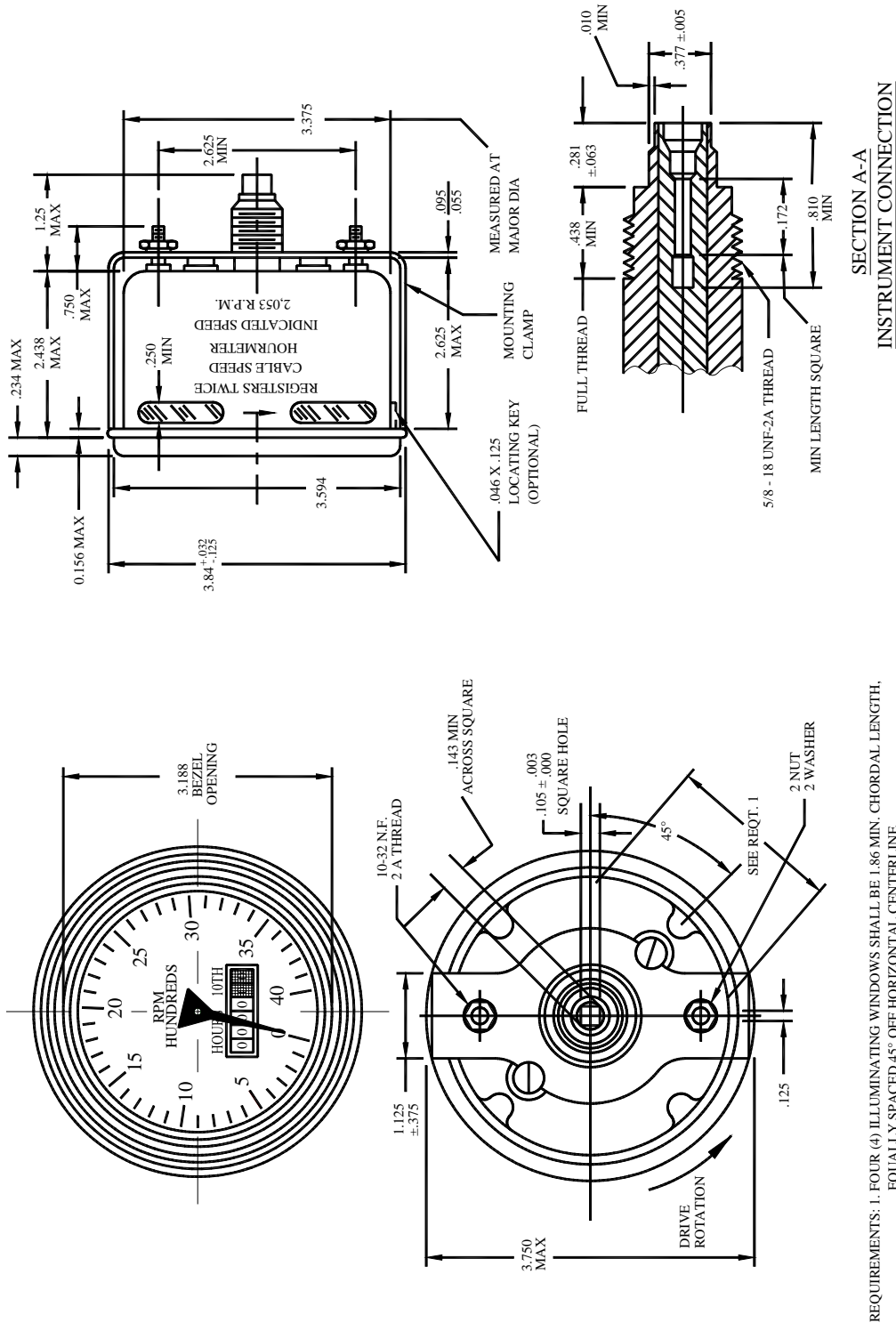

FIGURE 9. Tachometer, fixed mounting (4,000 rpm).

REQUIREMENTS: 1. FOUR (4) ILLUMINATING WINDOWS SHALL BE 1.86 MIN. CHORDAL LENGTH, EQUALLY SPACED 45° OFF HORIZONTAL CENTERLINE.  
OPTIONAL CONSTRUCTION: 360° ILLUMINATING WINDOW.

2. UNLESS OTHERWISE SPECIFIED, DIMENSIONS ARE IN INCHES, TOLERANCES ARE ±0.015 ON DECIMALS, ±1° ON ANGULAR DIMENSIONS.



MIL-DTL-10215L

Custodians:

Army – AT

Navy – MC

Preparing Activity:

DLA – GS8

(Project 6680-2008-001)

Review Activity:

Army – MI

NOTE: The activities listed above were interested in this document as of the date of this document. Since organizations and responsibilities can change, you should verify the currency of the information above using the ASSIST database at <http://assist.daps.dla.mil/>.