

MIL-C-85528/1
19 May 1983

MILITARY SPECIFICATION SHEET

CONNECTOR, ELECTRICAL, MOUNTING DEVICE, FLANGE TYPE,
FULL MOUNTING PERIMETER DEVICE, TYPE I (HEAVY DUTY)

This specification is approved for use by all Departments and Agencies of the Department of Defense.

The complete requirements for acquiring the mounting flanges described herein shall consist of this document and the latest issue of specification MIL-C-85528.

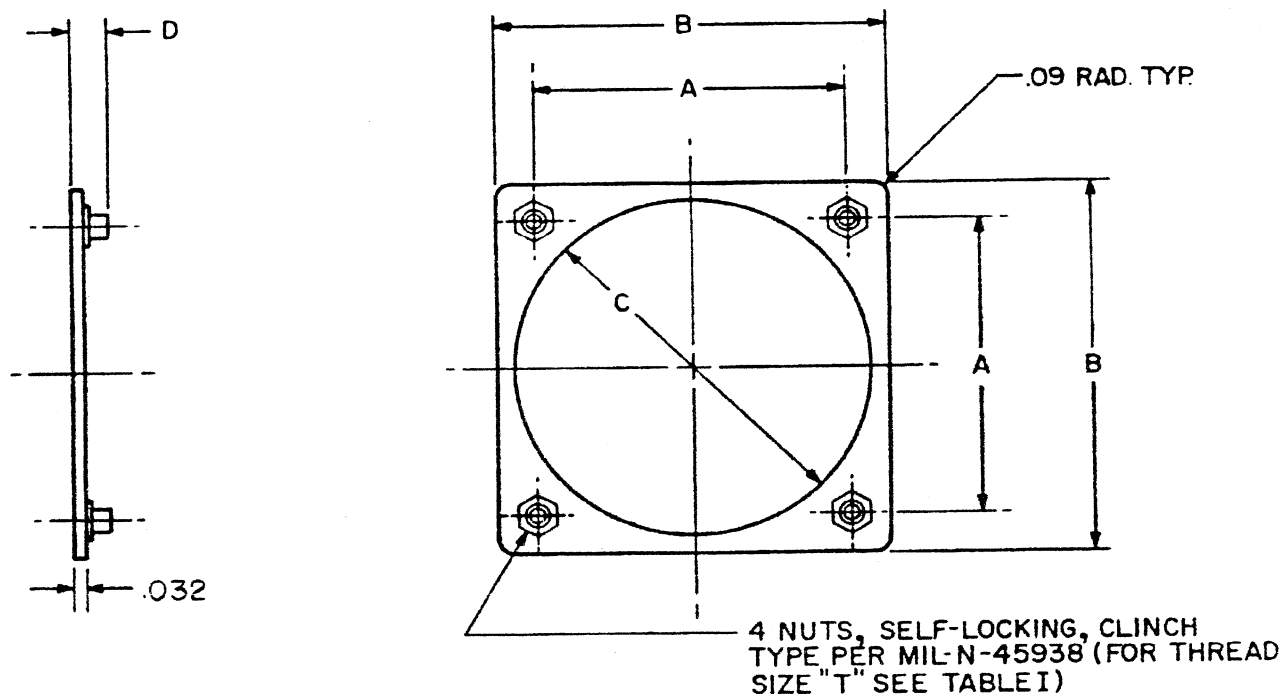

NOTES:

1. Dimensions are in inches.
2. Metric equivalents are given for general information only.
3. Unless otherwise specified, tolerance is $\pm .010$.
4. Shell size variances (see Table I).
5. Cross referencing-applications (see Table II).

FIGURE 1. Mounting flange, Type I.

MIL-C-85528/1

REQUIREMENTS:

Physical:

Material:

Mounting flange - Aluminum alloy .040 + .003 thk,
6061-T6 per QQ-A-250/11.

Nut, self-locking, clinch type, alloy steel per MIL-N-45938.
Cadmium plated per QQ-P-416, Type II. Supplementary molybdenum
disulfide coating.

Finish:

Mounting flange - Alodine per MIL-C-5541. Epoxy polyamide
primer, 2 coats, applied per MIL-P-23377, if required.
(See example.)

MILITARY PART NUMBER:

Example: M85528/1-8-A

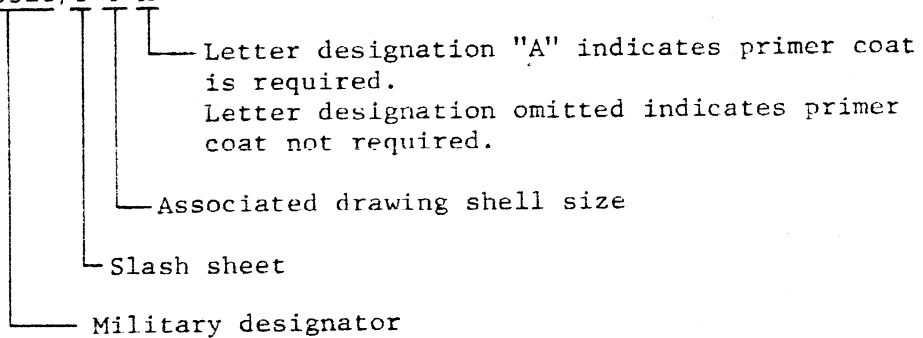
TABLE I. Mounting flanges.

PART NUMBER M85528/1-	SHELL SIZE	T THRD UNC3B	A \pm .003	B \pm .015	C \pm .015 -.000	D
8	8	4.40	.594	.800	.570	.106/.166
10	10	4.40	.719	1.005	.700	.106/.166
12	12	4.40	.812	1.098	.820	.106/.166
14	14	4.40	.906	1.192	.945	.106/.166
16	16	4.40	.969	1.255	1.070	.106/.166
18	18	4.40	1.062	1.348	1.196	.106/.166
20	20	4.40	1.156	1.500	1.320	.106/.166
22	22	4.40	1.250	1.625	1.440	.106/.166
24	24	6.32	1.375	1.750	1.570	.123/.183
25	25	6.32	1.500	1.891	1.658	.123/.183

TABLE II. Mounting flange cross reference Type I.

PROC SPEC	MIL-STD	SHELL SIZES								PART NO.	ASSOCIATED DRAWING SHELL SIZES															
MIL-C-5015	3100	8S	10	10S1	12S	12	14S	14	16S	16	18	MXXXX/1XA	8	10	--	12	12	14	14	16	16	18				
	3102	20	22	24	28	32	36	8S	10S	10S1	12S		12	14S	14	16S	16	18	8	10	--	12	12	14	14	16
MIL-C-26482	3110	8	10	12	14	16	18	20	22	24		8	10	12	14	16	18	20	22	24						
	3112	8	10	12	14	16	18	20	22	24		8	10	12	14	16	18	20	22	24						
	3120	8	10	12	14	16	18	20	22	24		8	10	12	14	16	18	20	22	24						
	3122	8	10	12	14	16	18	20	22	24		8	10	12	14	16	18	20	22	24						
	3470	8	10	12	14	16	18	20	22	24		8	10	--	--	--	--	--	--	--						
	3472	8	10	12	14	16	18	20	22	24		--	--	--	--	--	--	--	--	--						
MIL-C-81703	3130	3	7	12	19	27	37			--	10	--	--	--	--	--	--	--								
MIL-C-27599	20026	9	11	13	15	17	19	21	23	25		10	12	14	16	18	20	22	24	25						
	20030	9	11	13	15	17	19	21	23	25		10	12	14	16	18	20	22	24							
	27334	8	10	12	14	16	18	20	22	24		8	10	12	14	16	18	20	22	24						
	27335	8	10	12	14	16	18	20	22	24		8	10	12	14	16	18	20	22	24						
	27338	8	10	12	14	16	18	20	22	24		8	10	12	14	16	18	20	22	24						
	27339	8	10	12	14	16	18	20	22	24		8	10	12	14	16	18	20	22	24						
MIL-C-38999	27466	9	11	13	15	17	19	21	23	25		10	12	14	16	18	20	22	24	25						
	27469	9	11	13	15	17	19	21	23	25		10	12	14	16	18	20	22	24	--						
	27472	8	10	12	14	16	18	20	22	24		8	10	12	14	16	18	20	22	24						
	27475	8	10	12	14	16	18	20	22	24		8	10	12	14	16	18	20	22	24						
	27476	8	10	12	14	16	18	20	22	24		8	10	12	14	16	18	20	22	24						
	27496	9	11	13	15	17	19	21	23	25		10	12	14	16	18	20	22	24	25						
	27497	8	10	12	14	16	18	20	22	24		--	--	--	--	--	--	--	--	--						
	27499	8	10	12	14	16	18	20	22	24		8	10	12	14	16	18	20	22	24						
	27505	9	11	13	15	17	19	21	23	25		10	12	14	16	18	20	22	24	25						
	27508	8	10	12	14	16	18	20	22	24		8	10	--	--	--	--	--	--	--						
	27513	8	10	12	14	16	18	20	22	24		8	10	12	14	16	18	20	22	24						
	27515	9	11	13	15	17	19	21	23	25		10	12	14	16	18	20	22	24	25						
	MIL-C-81511	-----	--	--	--	--	--	--	--	--	--		--	--	--	--	--	--	--	--	--					
	MIL-C-83723	/1A	8	10	12	14	16	18	20	22	24		8	10	12	14	16	18	20	22	24					
/2B		8	10	12	14	16	18	20	22	24		8	10	12	14	16	18	20	22	24						
/3B		10	12	14	16	18	20	22	24		12	--	--	--	--	--	--	24	25							
/4B		10	12	14	16	18	20	22	24		12	--	--	--	--	--	24	25								

MIL-C-85528/1

MIL-C-85528/1

Custodians:

Army - CR
Navy - AS
Air Force - 85

Preparing activity:

Navy - AS
(Project No. 5935-3284-1)

Review activities:

Army - AR, MI
Navy - EC, SH
Air Force - 11, 99
DLA - ES

User activities:

Army
Navy
Air Force