

MILITARY SPECIFICATION

CONNECTORS AND ACCESSORIES, ELECTRICAL, CIRCULAR, UMBILICAL, ENVIRONMENT RESISTANT,
REMOVABLE CRIMP CONTACTS, FOR MIL-STD-1760 APPLICATIONS (METRIC),
GENERAL SPECIFICATION FOR

This specification is approved for use by all Departments
and Agencies of the Department of Defense

1 SCOPE

1.1 Scope This specification covers connectors and accessories, electrical, circular, umbilical. The connector assembly provides the necessary connections required to meet MIL-STD-1760, class I electrical interface between stores and their associated launchers using a "blind mating" mechanism. The connector assembly consists of a receptacle installed on the launcher, a receptacle installed on the store, and a buffer plug installed between the two receptacles. This specification also includes the required mounting adapters and nut, accessory adapter, cable bushing, and protective covers (see 6.1 for details on intended use and application)

1.2 Physical characteristics. The connector assembly (see figure 1) consists of a launcher receptacle, MIL-C-83538/4, a buffer plug, MIL-C-83538/3, and a store receptacle, MIL-C-83538/1. In addition, there are connector caps to protect the launcher receptacle and the store receptacle after they have been installed on launchers and stores and are not mated with the buffer plug. The launcher receptacle cap, MIL-C-83538/8, meets all the environmental, EMI, and retention requirements that apply to the buffer plug. The store receptacle cap, MIL-C-83538/7, meets the rain requirement of 5 centimeters (2 inches) per hour and the sand and dust requirement (see 3.37). The launcher receptacle accessory adapter, MIL-C-83538/9, mates with the same accessories in accordance with MIL-C-38999, series III and are covered in MIL-C-85049

1.2.1 Contact styles

- a. Connectors used with standard contact arrangements as indicated in MIL-STD-1560, 25-20, are as follows:

P - Pin: Buffer plug only (nonremovable).
S - Socket. Receptacles only (removable)

The "P" or "S" designators are used to indicate that connectors will be used with full complements of the applicable standard contacts as indicated in MIL-STD-1560.

Receptacles accommodate crimp removable contacts "(S)" and may be ordered without standard contacts by adding an appropriate note on the purchase order; however, the connector Part or Identifying Number (PIN) and the marking requirements remain unchanged (see 3.4.2 1, 3.39.1, and 6.2)

Beneficial comments (recommendations, additions, deletions) and any pertinent data which may be of use in improving this document should be addressed to 645 LOG/LGME, Gentile AFS, 1060 Hamilton Street, Dayton, OH 45444-5400, by using the Standardization Document Improvement Proposal (DD Form 1426) or by letter

AMSC N/A

DISTRIBUTION STATEMENT A Approved for public release, distribution is unlimited

FSC 5935

MIL-C-83538

- b Receptacles used with other than standard contact arrangements as indicated in MIL-STD-1560 are as follows

B - Socket contact insert

The "B" designator is used to indicate that the connectors will be used with other than standard contacts as indicated in MIL-STD-1560 (example. PC board, thermocouple, contacts) The "B" designator is part of the connector PIN and is marked on the receptacles

The standard contacts are not supplied with the receptacles. The contacts that will be used with the receptacles must be ordered separately (see 3 4 2 1, 3 4 2, and 6 2)

2 APPLICABLE DOCUMENTS

2 1 Government documents

2 1.1 Specifications, standards, and handbooks. The following specifications, standards, and handbooks form a part of this document to the extent specified herein. Unless otherwise specified, the issues of these documents are those listed in the issue of the Department of Defense Index of Specifications and Standards (DODISS) and supplement thereto, cited in the solicitation (see 6 2)

SPECIFICATIONS

FEDERAL

- QQ-N-290 - Nickel Plating (Electrodeposited)

MILITARY

- MIL-T-5624 - Turbine Fuel, Aviation, Grades JP-4 and JP-5
 MIL-C-22520 - Crimping Tools, Terminal, Hand or Power Actuated, Wire Termination, and Tool Kits, General Specification for.
 MIL-C-39029 - Contacts, Electrical Connector, General Specification for.
 MIL-G-45204 - Gold Plating, Electrodeposited.
 MIL-A-46146 - Adhesive Sealants, Silicone, RTV, Non-Corrosive (For Use with Sensitive Metals and Equipment).
 MIL-C-55330 - Connectors, Electrical And Fiber Optic, Packaging of
 MIL-I-81969 - Installing and Removal Tools, Connector, Electrical Contact, General Specification for
 MIL-C-85049 - Connector Accessories, Electrical, General Specification for.

STANDARDS

MILITARY

- MIL-STD-454 - Standard General Requirements for Electronic Equipment.
 MIL-STD-790 - Product Assurance Program for Electronic and Fiber Optic Parts Specifications.
 MIL-STD-810 - Environmental Test Methods.
 MIL-STD-1285 - Marking of Electrical and Electronic Parts
 MIL-STD-1344 - Test Methods for Electrical Connectors
 MIL-STD-1472 - Human Engineering Design Criteria for Military Systems, Equipments and Facilities
 MIL-STD-1560 - Insert Arrangements for MIL-C-38999 Connectors
 MIL-STD-1760 - Aircraft/Store Electrical Interconnection System
 MIL-STD-45662 - Calibration Systems Requirements.
 MS9068 - Packing, Preformed - AMS 3304, or AMS 3325 or AMS 3326
 MS27488 - Plug, Sealing, Electrical Connector
 MS90376 - Caps, Dust, Plastic, Electrical Connector

(See supplement 1 for list of associated specifications)

MIL-C-83538

(Unless otherwise indicated, copies of federal and military specifications, standards, and handbooks are available from the Defense Printing Service Detachment Office, Building 4D (Customer Service), 700 Robbins Avenue, Philadelphia, PA 19111-5094)

2.2 Non-Government publications. The following documents form a part of this document to the extent specified herein. Unless otherwise specified, the issues of the documents which are DoD adopted are those listed in the issue of the DODISS cited in the solicitation. Unless otherwise specified, the issues of documents not listed in the DODISS are the issues of the documents cited in the solicitation (see 6.2)

ELECTRONIC INDUSTRIES ASSOCIATION (EIA)

- | | | |
|------------|---|---|
| EIA RS-359 | - | EIA Standard Colors For Color Identification and Coding (ANSI C-83 1-1973) |
| EIA-364 | - | EIA Standard For Insert Bonding Integrity. |
| EIA-557 | - | EIA Standard Implementation of Statistical Process Control (SPC) in Manufacturing Process |

(Application for copies should be addressed to the Electronic Industries Association, 2001 Eye Street, NW, Washington, DC 20006.)

INTERNATIONAL STANDARDS ORGANIZATIONS

- | | | |
|---------------|---|---|
| ISO/R68-1973 | - | ISO-Basic Profile for Triangular Screw Threads, .25 to 5 mm. |
| ISO/R261-1973 | - | ISO-Metric Screw Threads, General Plan, .25 to 300 mm |
| ISO/R262-1973 | - | ISO-Metric Screw Threads for Screws, Bolts, and Nuts, 6 to 39 mm |
| ISO/R965-1973 | | |
| Part 1 | - | ISO General Purpose Metric Screw Threads, Tolerances, Principles and Basic Data |
| Part 2 | - | ISO General Purpose Metric Screw Threads, Tolerances, Limits of Sizes for Medium Quality Commercial Bolt And Nut Threads 1.6 to 39 mm |
| Part 3 | - | ISO General Purpose Metric Screw Threads, Tolerances and Deviations for Constructional Threads, Tolerances 1.6 to 355 mm. |

(Application for copies should be addressed to the American National Standard Institute, 1430 Broadway, New York, NY 10018.)

2.3 Order of precedence In the event of a conflict between the text of this document and the references cited herein (except for related associated detail specifications, or specification sheets), the text of this document takes precedence. Nothing in this document, however, supersedes applicable laws and regulations unless a specific exemption has been obtained.

3 REQUIREMENTS

3.1 Specification sheets. The individual item requirements shall be as specified herein and in accordance with the applicable specification sheet. In the event of any conflict between the requirements of this specification and the specification sheet, the latter shall govern.

3.2 Qualification. Connectors furnished under this specification shall be products which are authorized by the qualifying activity for listing on the applicable qualified products lists at the time of award of contract (see 4.4 and 6.3)

3.2.1 Reliability. The contractors reliability program for assembled connectors and assembly procedures shall meet the requirements of MIL-STD-790 with the exception that the failure reporting period shall be 12 months in lieu of 6 months.

3.2.2 Quality.

3.2.2.1 Statistical process control (SPC) The contractor shall implement and use statistical process control techniques in the manufacturing process for parts covered by this specification. The SPC program shall be developed and maintained in accordance with EIA-557. The SPC program shall be documented and maintained as part of the overall reliability assurance program as specified in MIL-STD-790

MIL-C-83538

3.3 Materials

3.3.1 Environmental safety Highly toxic or carcinogenic materials shall not be used in the fabrication or maintenance of the connector assembly.

3.3.2 Metals Metals shall be of a corrosion-resistant type or shall be plated or treated to resist corrosion.

3.3.2.1 Dissimilar metals and compatible couples When dissimilar metals are used in intimate contact with each other, protection against galvanic corrosion shall be provided. The use of dissimilar metals in contact, which tend toward active galvanic corrosion (particularly brass, copper, or steel used in contact with aluminum or aluminum alloy) is not acceptable. However, metal plating of dissimilar base metals to provide similar or suitable abutting surfaces is permitted. The use of dissimilar metals separated by a suitable insulating material is also permitted. Dissimilar metals and compatible couples are defined in requirement 16 of MIL-STD-454.

3.3.3 Components Materials for specific components of the connector shall be as follows.

- a. Shell: Corrosion-resistant steel.
- b. Coupling ring: Corrosion-resistant steel.
- c. Insert: Reinforced epoxy resin or other suitable rigid dielectric.
- d. Spring fingers: Heat-treated beryllium copper or corrosion-resistant steel.
- e. Filler compound: RTV silicone in accordance with MIL-A-46146, or equivalent.
- f. Gasket, grommet, and interfacial seal: Silicone or fluorosilicone.

3.3.4 Fungus resistant. Materials used in the construction of these connectors shall be fungus inert in accordance with requirement 4 of MIL-STD-454.

3.3.5 Magnetic permeability The relative permeability of the wired, assembled, and fully mated connector assembly shall be less than 2.0 when measured in accordance with 4.7.35.

3.4 Design and construction Connectors and accessories shall be designed and constructed to withstand normal handling incident to installation and maintenance in service.

3.4.1 Human performance/human engineering The connector assembly design shall be directed toward simplicity and error-free ease of installation and maintenance. The requirements of MIL-STD-1472 shall be met, as appropriate, with emphasis on areas including personnel safety, component marking, and component alignment and keying for blind mate operations. The design of the buffer plug shall be such that the buffer plug can be installed on the launcher receptacle without special tools and with personnel wearing nuclear/biological/chemical warfare protective clothing (specifically, gloves or arctic gloves). The forces available for gripping the buffer plug are covered in MIL-STD-1472 (arm, hand, thumb, and finger sustained hold: 35 newtons (about 8 pounds)). The space in the rail launcher allows room for only the thumb and one finger when wearing biological/chemical warfare or arctic gloves.

3.4.2 Contacts Contacts used in this connector shall be standard crimp contacts qualified to MIL-C-39029. The twinaxial socket contacts shall be in accordance with MIL-C-39029/91. The high bandwidth 1 and 2 coaxial socket contacts shall be in accordance with MIL-C-39029/103. The high bandwidth 3 and 4 coaxial socket contacts shall be in accordance with MIL-C-39029/75. The power and discrete socket contacts shall be in accordance with MIL-C-39029/56. The buffer plug shall contain a full set of nonremovable pin contacts. Unless otherwise specified in the purchase order, each receptacle shall contain a full complement of socket contacts with each connector unit package.

3.4.2.1 Contact arrangement The contact arrangement shall comply with the 25-20 arrangement of MIL-STD-1560. The engaging end of the pin contact in assembled connectors shall be located within 0.61 mm (0.024 inch) diameter of true position and the engaging end of socket contacts in assembled connectors shall be located within 0.38 mm (0.015 inch) diameter of true position. Test voltages for service ratings shall be in accordance with table XI.

MIL-C-83538

3.4.2.2 Installing and removal tools. Both the MIL-I-81969/8 and the MIL-I-81969/14 tools shall properly assemble and disassemble the socket contacts into their connector inserts. Unless otherwise specified in the purchase order, one MIL-I-81969/14 tool for each contact size shall be enclosed in the unit package. For indirect shipments, connectors may be ordered without installing and removal tools (see 6.2).

3.4.3 Insert design. The insert and wire sealing or wire supporting member of the connector shall be designed to provide suitable sealing and support around the wires installed in the connector. The design shall permit the removal and replacement of individual contacts into the launcher receptacle and store receptacle insert with the tools defined in 3.4.2.2. Individual contacts in the buffer plug are not removable. The contact locking device shall be sufficient to meet the contact retention requirements of 3.18. Inserts shall be secured in the connector shell to prevent rotation or axial movement.

3.4.4 Sealing

3.4.4.1 Wire sealing. Assemblies shall be designed to meet the environmental requirements of this specification using wire outer diameter within the applicable range as shown in table I.

TABLE I. Wire sizes and diameters

Contact size	Wire size (AWG)	Finished wire outside dimensions			
		Minimum		Maximum	
		mm	Inches	mm	Inches
20	24, 22, 20	1.02	.040	2.11	.083
16	20, 18, 16	1.65	.065	2.77	.109
12 coaxial	14, 12	2.46	.097	3.61	.142
8 twinaxial	M17/176-00002	3.15	.124	3.40	.134

3.4.4.2 Sealing plugs. Store receptacles shall be designed to accept sealing plugs in accordance with MS27488 in lieu of wire where unwired contacts are employed. Sealing plugs in accordance with MIL-C-85049/80 for coaxial, triaxial, or concentric twinaxial contact locations may be used to eliminate requiring the installation of an unwired contact in the launcher receptacle or store receptacle. These sealing plugs, when installed in the receptacles, shall not preclude the mating of a buffer plug that is fully populated with pin contacts. Unless otherwise specified in the purchase order, no sealing plugs shall be enclosed with the receptacle package.

3.4.4.3 Mating seal. Connectors with pin inserts shall have a resilient face with individual pin barriers (see figure 2). The pin barrier projections shall seal in their respective lead-in chambers of the hard face socket insert. The resilient interfacial seal shall provide individual contact seals in the mated condition to ensure circuit isolation between each contact and contact to shell. The receptacles shall be provided with a peripheral seal.

3.4.5 Shell. The store receptacle design shall allow mounting of the receptacle flush with the store outer skin. Shells, including mounting flanges, shall be of one-piece construction and shall be designed to retain their inserts in one position, both axially and with respect to rotation, by mechanical means. Adhesive may be used as a supplementary retention means for environmental resisting connectors. Each receptacle connector shall have at least one blue color band in accordance with EIA RS-359, indicating a rear release contact retention system. The blue color band shall be located so that it is readily visible to any person servicing a mounted connector.

3.4.5.1 Shell spring fingers. Spring fingers shall be designed to make electrical contact with the mating shell without interfering with proper engagement. The springs shall be retained about the shell periphery.

3.4.5.2 Jam-nut mounting receptacles. Jam-nut mounting receptacles shall be provided with a mounting nut, MIL-C-83538/6, with provisions for locking, and an O-ring (MS9068).

3.4.5.3 Weight. The launcher receptacle (including the buffer plug unit) shall not exceed 180 grams and the store receptacle shall not exceed 160 grams. These weights include mounting provisions but do not include accessory hardware (such as cable clamps) and do not include the launcher receptacle engagement/disengagement mechanism.

MIL-C-83538

3.4.6 Screw threads Screw threads shall conform to ISO/R68-1973, ISO/R261-1973, ISO/R262-1973, and ISO/R965-1973, as applicable. Threads shall be checked using ring or plug gauges. Slight out-of-roundness beyond the specified tolerances is acceptable if threads can accept the gauges without forcing.

3.4.7 Installation The launcher receptacle and associated buffer plug are designed for installation in an engagement/disengagement mechanism in the launcher. This mechanism provides the engagement and retraction forces for mating and unmating the connector assembly. The connector assembly (see figure 1) shall comply with the alignment requirements herein during and after exposure to any logical combination of environment requirements defined herein.

3.4.7.1 Alignment provisions The launcher receptacle/buffer plug assembly and store receptacle shall include self-alignment provisions. The interface between the launcher receptacle connector and the buffer plug shall be scoop-proof and keyed.

3.4.7.2 Applied holding force. The force required to maintain sufficient mating of the combined launcher receptacle/buffer plug assembly and store receptacle for complying with the requirements herein shall not exceed 289 newtons (65 pounds) $\pm 10\%$.

3.4.8 Cavity fill If the rear grommet design does not allow for intimate contact between it and the complete inner perimeter of the shell, any resulting cavity between the insert and the shell shall be filled with RTV silicone conforming to MIL-A-46146, or equivalent.

3.4.9 Plating

3.4.9.1 Contacts (buffer plug unit) Contacts shall be gold-plated to a minimum thickness of 0.00127 mm (.000050 inch) in accordance with MIL-G-45204 over a suitable underplate. Silver underplate shall not be used.

3.4.9.1.1 Contacts (crimp). The plating and plating thickness on crimp contacts shall be as specified in MIL-C-39029.

3.4.9.2 Shells and coupling ring. Electrodeposited nickel in accordance with QQ-N-290, class 2, 0.003 to 0.005 mm (.0001 to .0002 inch) thickness.

3.4.9.2.1 Shell spring fingers. Shell spring fingers shall be suitably protected to prevent corrosion.

3.4.10 Exhaust heat The launcher receptacle, when protected by a buffer plug or receptacle cover, shall withstand, without damage, direct impingement of rocket motor exhaust. The replaceable buffer plug shall retain structural integrity and remain attached to the launcher receptacle during and after exposure to the above cycle. The launcher receptacle shall retain a minimum insulation resistance of 10 megohm contact-to-contact and contact-to-shell during and after exposure.

3.5 Interchangeability. All major components (launcher receptacle, store receptacle, buffer plug unit, accessories and contacts) of the connector assembly having the same PIN shall be completely interchangeable with each other with respect to installation and performance.

3.6 Maintenance aging. When tested as specified in 4.7.2, the contact installing and removal forces shall not exceed the requirements of table II.

TABLE II Installing and removal forces

Contact size	Installing and removal forces (maximum)	
	Newtons	Pounds
20	89	20
16	89	20
12	133	30
8 Triaxial	156	35

MIL-C-83538

3.7 Temperature cycling When tested as specified in 4.7.3, there shall be no blistering, peeling, or separation of plating or other damage detrimental to the operation of the connector. The test temperatures shall be -65°C minimum to $+200^{\circ}\text{C}$ maximum.

3.8 Coupling

3.8.1 Coupling torque of bayonet coupled components. When tested as specified in 4.7.4.1, the coupling torque for mating and unmating of the launcher receptacle from the buffer plug and protective covers from launcher receptacle shall be 4.1 newton-meters (3 ft-lb) maximum and shall be not less than 0.6 newton-meters (5 ft-lb) for unmating. The torque for mating and unmating the protective cover from the store receptacle shall be 1.5 newton-meters (1.2 ft-lb) maximum and shall be not less than 0.3 newton-meters (.25 ft-lb) for unmating.

3.8.2 Coupling force. When tested as specified in 4.7.4.2, the coupling force for mating and unmating the combined launcher receptacle/buffer plug assembly from the store receptacle shall not exceed 262 newtons (59 pounds). These forces do not apply under the ice and freezing rain conditions of 3.36.

3.8.3 Decoupling rate When tested as specified in 4.7.4.3, the decoupling rate shall achieve full separation within 50 milliseconds following application of a 320 newton force (72 pounds) along the Z axis $\pm 10^{\circ}$ (see figure 3). Full separation shall be achieved after 25 mm maximum movement of the combined launcher receptacle/buffer plug assembly and store receptacle from the full mated position. During this decoupling, the buffer plug shall remain attached to the launcher receptacle.

3.8.4 Self-alignment. When tested as specified in 4.7.4.4, the self-alignment provisions between the launcher receptacle/buffer plug assembly and the store receptacle shall be such that these assemblies will mate even if they are simultaneously initially misaligned by the following (see figure 3 for axis and angle definitions):

X axis: ± 2.03 mm (.08 inch)
 Y axis: ± 2.03 mm (.08 inch)
 Angle a: $\pm 5^{\circ}$
 Angle b: $\pm 5^{\circ}$
 Angle c: $\pm 5^{\circ}$

3.8.5 Holding force The launcher receptacle, buffer plug, and store receptacle shall be capable of withstanding a holding force of 890 newtons (200 pounds) maximum.

3.9 Durability. When tested as specified in 4.7.5, the launcher receptacle and store receptacle shall comply with the performance requirements herein after 500 mating and unmating cycles, at each mating interface.

3.10 Altitude immersion (qualification only). When tested as specified in 4.7.6, the mated connector pair shall have a minimum insulation resistance as specified in 3.11.1 and dielectric withstanding voltage as specified in 3.12.

3.11 Insulation resistance.

3.11.1 Insulation resistance at ambient temperature. When tested as specified in 4.7.7.1, the insulation resistance between any pair of contacts and between any contact and the shell shall be greater than 5,000 megohms. Insulation resistance after altitude immersion shall be 1,000 megohms minimum. Insulation resistance after humidity shall be 100 megohms minimum.

3.11.2 Insulation resistance at elevated temperature. When tested as specified in 4.7.7.2, the insulation resistance between any pair of contacts and between any contact and the shell shall be greater than 1,000 megohms.

3.12 Dielectric withstanding voltage When tested as specified in 4.7.8.1 or 4.7.8.2, the maximum leakage current shall be 2 milliamperes, and there shall be no evidence of electric breakdown or flashover.

3.13 Insert retention When tested as specified in 4.7.9, unmated connectors shall retain their inserts in their proper location in the shell and there shall be no evidence of cracking, breaking, separation from the shell, or loosening of parts.

MIL-C-83538

3.14 Salt spray (corrosion) When tested as specified in 4.7.10, unmated connectors shall show no exposure of basis material due to corrosion which will adversely affect performance.

3.15 Electrical engagement When tested as specified in 4.7.11, wired, mated connectors shall provide a minimum of 1.27 mm (.050 inch) electrical engagement.

3.16 Gauge location Using test gauges conforming to figure 4, the axial location of contacts shall be measured as specified in 4.7.12. Gauge location measurements shall fall within the range specified (see 3.1).

3.17 Gauge retention When tested as specified in 4.7.13, the test gauges conforming to figure 5 shall be retained in the contact cavities and the axial displacement of the test gauges while under load shall not exceed 0.03 mm (.012 inch).

3.18 Contact retention. When tested as specified in 4.7.14, the axial displacement of the contact shall not exceed 0.03 mm (.012 inch). No damage to contacts or inserts shall result.

3.19 Altitude (low temperature). When tested as specified in 4.7.15, the connector shall meet the requirements of dielectric withstanding voltage at sea level specified in 3.12 and insulation resistance at ambient temperature specified in 3.11.

3.20 Accessory thread strength. When tested as specified in 4.7.16, the launcher receptacle and store receptacle shall be capable of withstanding a torque of 28.3 ± 2.8 newton-meters (20 ± 2 ft-lb).

3.21 Vibration (qualification only). When tested as specified in 4.7.17, there shall be no electrical discontinuity and there shall be no disengagement of the mated connectors, backing off of the coupling mechanism, evidence of cracking, breaking, or loosening of parts.

3.22 Shock. When tested as specified in 4.7.18, there shall be no electrical discontinuity and there shall be no disengagement of the mated connectors, evidence of cracking, breaking, or loosening of parts.

3.23 Shell-to-shell conductivity. When tested as specified in 4.7.19, the resistance from launcher receptacle shell to the buffer plug of a mated launcher receptacle/buffer plug assembly shall not exceed 2.5 millionohms. The resistance from launcher receptacle overbraid attachment point to the store receptacle adapter plate (as defined on MIL-C-83538/1) shall not exceed 8 millionohms. After conditioning (salt spray and coupling torque) the above values may increase 100 percent.

3.24 Humidity. When tested as specified in 4.7.20, wired, mated connectors shall show no deterioration which will adversely affect performance of the connector. Following the test, and during the final cycle, insulation resistance shall be 100 megohms or greater.

3.25 Shell spring finger forces When tested as specified in 4.7.21, the forces necessary to engage and separate plugs with receptacle shells shall be within the axial force of 2 newtons (.5 pound) minimum, and 156 newtons (35 pounds) maximum.

3.26 EMI shielding When tested as specified in 4.7.22, the EMI shielding capabilities of mated shells shall be not less than that specified in table III at the specified frequencies.

MIL-C-83538

TABLE III. EMI shielding effectiveness

Frequency MHz	Leakage attenuation (dB) Minimum
0.2 to 100	90
200	88
300	88
400	87
800	85
1,000	85
1,500	76
2,000	70
3,000	69
4,000	68
6,000	66
10,000	65

3.27 Insertion Loss. When tested as specified in 4.7.23, the mated connector shall comply with the applicable contact resistance requirements of MIL-C-39029 for all contacts except the total allowed resistance though the combined mated triplet of launcher receptacle, buffer plug, and store receptacle shall not exceed 2.0 times the limit of MIL-C-39029 for the applicable size contacts. In addition, the coaxial contacts for the high bandwidth signals shall provide a maximum attenuation of.

a. High bandwidth 1, referenced to 50 ohms:

20 Hz to 20 MHz measured insertion loss shall not exceed 0.20 dB.
 20 MHz to 500 MHz measured insertion loss shall not exceed 0.12 dB
 500 MHz to 1.6 GHz the measured insertion loss shall not exceed
 $0.11 \text{ dB} \times \sqrt{F}$, where F is the test frequency in GHz.

b. High bandwidth 2, referenced to 50 ohms: 20 Hz to 20 MHz measured insertion loss shall not exceed 0.20 dB

c. High bandwidth 3 and 4, referenced to 75 ohms 20 Hz to 20 MHz measured insertion loss shall not exceed 0.20 dB.

3.28 Voltage standing wave ratio When tested as specified in 4.7.24, the mated connector shall provide a maximum voltage standing wave ratio of 1.75 for the high bandwidth signals over the frequency range of:

a. 20 Hz to 1.6 GHz for high bandwidth 1 referenced to 50 ohms.

b. 20 Hz to 20 MHz for high bandwidth 2 referenced to 50 ohms

c. 20 Hz to 20 MHz for high bandwidth 3 and 4 referenced to 75 ohms.

3.29 Ozone. When tested as specified in 4.7.25, the connectors shall show no evidence of cracking of dielectric material or other damage due to ozone exposure that will adversely affect performance.

3.30 Acoustic noise. When tested as specified in 4.7.26, the connector assembly shall withstand exposure to the acoustic noise levels defined in MIL-STD-810, method 515, procedure II, category I with L_0 of 160 dB, f_0 of 1,000 Hz and a duration of 30 hours. There shall be no electrical discontinuity during this test when the holding forces of 3.4.7.2 are applied. There shall be no disengagement of the mated connectors, evidence of cracking, breaking, or loosening of parts.

3.31 Fluid immersion When tested as specified in 4.7.27, connectors shall meet the requirements for coupling torque (see 3.8) and dielectric withstanding voltage (see 3.12)

3.31.1 Retention system fluid immersion When tested as specified in 4.7.28, the insert assemblies shall meet the requirements of contact retention (see 3.18). Effects of the fluids on resilient sealing members shall not be a consideration of this test.

MIL-C-83538

3.32 Contact walkout When tested as specified in 4.7.29, contacts shall not become dislodged from their normal position

3.33 Installing/removal tool abuse (qualification only) When tested as specified in 4.7.30, there shall be no evidence of damage to the contacts, the connector insert, or the contact retaining mechanism

3.34 High temperature exposure

3.34.1 High temperature exposure with contact loading When tested as specified in 4.7.31.1, the contacts shall maintain their specified locations as shown (see 3.1) and there shall be no electrical discontinuity

3.34.2 High temperature exposure When tested as specified in 4.7.31.2 for 1,000 hours, connectors shall perform satisfactorily and pass succeeding tests in the qualification test sequence

3.34.3 Postlaunch temperature. When tested as specified in 4.7.31.3, the store receptacle shall retain structural integrity and shall retain a minimum insulation resistance of 10 megohms contact-to-contact and contact-to-shell during and after exposure of its mating surface to a temperature soak of 480°C for a duration of 5 minutes.

3.35 Electrolytic erosion. When tested as specified in 4.7.32, pin contacts shall show no exposure of base metal due to electrolytic erosion. Corrosion deposits shall not be considered as defects.

3.36 Icing and freezing rain When tested as specified in 4.7.33, the connector assembly shall withstand the icing and freezing rain environment (see spray condition) specified in 4.7.33. The force required to separate the connector shall not exceed 333 newtons (75 pounds)

3.37 Sand and dust. When tested as specified in 4.7.34, the connector assembly shall withstand the blowing dust and blowing sand conditions of MIL-STD-810, method 510. Blowing dust air velocity shall be 8.9 meters/second minimum. The blowing sand air velocity shall be 29 meters/second minimum with a sand concentration of 2.2 ± 0.5 grams/cubic meter. Immediately following this exposure, the coupling force and decoupling force shall not exceed the requirements specified herein (see 3.8.2 and 3.8.3) by more than 25 percent

3.38 Insert bonding integrity when tested as specified in 4.7.37, there shall be no air leakage between contact cavities

3.39 Marking The launcher receptacle, store receptacle, buffer plug unit, and accessories shall be permanently marked with the manufacturer's name or trademark, date code, and the following information, as applicable. Stamping shall be in accordance with MIL-STD-1285 where space permits. Metal stamping shall be accomplished before plating. The following is an example of the Part or Identifying Number (PIN).

M83538/**	*	*	**	*	*
Specification sheet no. (see supplement)	Class (see 3.1)	Shell size (see 3.1)	Insert arrangement (see MIL-STD-1560)	Contact style (see 1.3.1)	Adapter type (see 3.1)

3.39.1 Contact location identification Contact locations shall be identified as indicated on the applicable military standard. All positions shall be identified on the front and rear faces of the insert except where space limitations make this impracticable. Location of contact identifying characters shall be in close proximity to the holes but need not be placed exactly where indicated on the standard. The preferred color of the contact identifying character is white. When the background is a color against which white is difficult to distinguish, a color will be chosen for which the identifying character can be easily distinguished

MIL-C-83538

3.39.2 JAN brand. The United States Government has adopted, and is exercising legitimate control over the certification marks "JAN" and "J", respectively, to indicate that items so marked or identified are manufactured to, and meet all the requirements of military specifications. Accordingly, items acquired to, and meeting all of the criteria specified herein and in applicable specifications shall bear the certification mark "JAN" except that items too small to bear the certification mark "JAN" shall bear the letter "J". The "JAN" or "J" shall be placed immediately before the PIN except that if such location would place a hardship on the manufacturer in connection with such marking, the "JAN" or "J" may be located on the first line above or below the PIN. Items furnished under contracts or orders which either permit or require deviation from the conditions or requirements specified herein or in applicable specifications shall not bear "JAN" or "J". In the event an item fails to meet the requirements of this specification and the applicable specification sheets or associated detail specification, the manufacturer shall remove the "JAN" or the "J" from the sample tested and also from all items represented by the sample. The "JAN" or "J" certification mark shall not be used on products acquired to contractor drawings or specification. The United States Government has obtained Certificate of Registration Number 504,860 for the certification mark "JAN".

3.40 Workmanship. The connector assembly and associated components shall be fabricated in accordance with requirement 9 of MIL-STD-454. Particular attention shall be given to neatness and thoroughness of marking parts, plating, welding, soldering, staking, and bonding. The connector components shall be free from crazing, cracks, knit-lines, flow-lines, voids, pimples, chips, blisters, pinholes, sharp cutting edges, burrs, and other defects that will adversely affect life, serviceability, or appearance.

4 QUALITY ASSURANCE PROVISIONS

4.1 Responsibility for inspection. Unless otherwise specified in the contract or purchase order, the contractor is responsible for the performance of all inspection requirements (examinations and tests) as specified herein. Except as otherwise specified in the contract or purchase order, the contractor may use his own or any other facilities suitable for the performance of the inspection requirements specified herein, unless disapproved by the Government. The Government reserves the right to perform any of the inspections set forth in this specification where such inspections are deemed necessary to ensure supplies and services conform to prescribed requirements.

4.1.1 Responsibility for compliance. All items shall meet all requirements of sections 3 and 5. The inspections set forth in this specification shall become a part of the contractor's overall inspection system or quality program. The absence of any inspection requirements in the specification shall not relieve the contractor of the responsibility of ensuring that all products or supplies submitted to the Government for acceptance comply with all requirements of the contract. Sampling inspection, as part of manufacturing operations, is an acceptable practice to ascertain conformance to requirements, however, this does not authorize submission of known defective material, either indicated or actual, nor does it commit the Government to accept defective material.

4.1.2 Test equipment and inspection facilities. Test and measuring equipment and inspection facilities of sufficient accuracy, quality, and quantity to permit performance of the required inspections shall be established and maintained by the contractor. The establishment and maintenance of a calibration system to control the accuracy of the measuring and test equipment shall be in accordance with MIL-STD-45662.

4.1.3 Reliability assurance program. A reliability assurance program shall be established and maintained in accordance with MIL-STD-790. Evidence of such compliance shall be verified by the qualifying activity of this specification as a prerequisite for qualification and continued qualification.

4.1.3.1 Statistical process control (SPC). A SPC program shall be established and maintained in accordance with EIA-557. Evidence of such compliance shall be verified by the qualifying activity as a prerequisite for qualification and retention of qualification.

4.1.4 Fungus resistance certification. Certification of requirement 4 of MIL-STD-454 is required (see 3.3.4).

MIL-C-83538

4.2 Classification of inspections The inspection requirements specified herein are classified as follows

- a Qualification inspection (see 4.4)
- b Quality conformance inspection (see 4.5)

4.3 Inspection conditions Unless otherwise specified herein, all inspections shall be performed in accordance with the test conditions specified in the "GENERAL REQUIREMENTS" of MIL-STD-1344

4.4 Qualification inspection. Qualification inspection shall be performed at a laboratory acceptable to the Government (see 6.3) on sample units produced with equipment and procedures normally used in production. Qualification approval may be granted upon successful completion of the inspections and tests of 4.4.3 conducted on samples of 4.4.1; such approval to include classes, finishes, shell configurations, and insert arrangements other than those actually tested providing that the capability to manufacture these parts is demonstrated by providing exhibit samples.

4.4.1 Sample size. The following test samples, manufactured by normal production methods, shall be provided. Tested and untested connectors, accessories and materials may be required at no cost to the Government for qualification verification by the responsible qualification activity (see 6.3).

- a Each test group (except group 4 and group 5) in table VI shall consist of four mating sets of the combined launcher receptacle/buffer plug and store receptacle. Connectors shall be fitted with MIL-C-85049 straight strain relief accessories.
- b Test group 4 in table VI shall consist of 10 mating sets of the combined launcher receptacle /buffer plug and store receptacle. Connectors shall be fitted with MIL-C-85049 straight strain relief accessories.
- c. Test group 5 in table VI shall consist of 10 launcher receptacles and 11 store receptacles. Connectors shall be fitted with MIL-C-85049 straight strain relief accessories.

4.4.2 Preparation of samples. Except as otherwise specified for shielded contacts, wiring of crimp-type contacts shall be accomplished using tools conforming to MIL-C-22520, class I. The length of stripped portion of conductor shall be at least long enough to reach the bottom of the crimp barrel, but shall not be so long that more than 0.79 mm (.031 inch) of conductor is exposed at end of the barrel when conductor end touches bottom of barrel. Samples provided as specified in 4.4.1 shall be wired with wire having a smooth extruded jacket of waterproof construction. Two samples shall have wires as listed for maximum diameter and the other two samples shall have wires as listed for minimum diameter in table V. Two power contact cavities of each sample provided shall contain unwired contacts and sealing plugs in accordance with MS27488.

TABLE V Test wire sizes.

Contact size	Maximum diameter	Minimum diameter
20	M22759/7-20 M22759/8-20	M22759/18, /19, /32, /33 -22 M22759/44, /45, /46 -22 M22759/11, /12, /13, /14 -24 M22759/22, /23
16	M22759/3, /4, /7, or /8 -16	M22759/18, /19, /32, M22759/44, /45 -16
12 coaxial/shielded	M17/94-RG179 M17/113-RG316	M17/94-RG179 M17/113-R316
8 twinaxial	M17/176-00002	M17/176-00002

MIL-C-83538

4.4.3 Test routine Samples provided in accordance with 4.4.1 shall be subjected to each test group in table VI in the order shown.

4.4.3.1 Failures One or more failures shall be cause for refusal to grant qualification

TABLE VI Qualification and group C periodic test

Inspection	Requirement paragraph	Test paragraph
<u>Group 1</u>		
Visual and mechanical examination	3.1, 3.3, 3.4, 3.5, 3.39, and 3.40	4.7.1
Magnetic permeability	3.3.5	4.7.35
Self-alignment	3.8.4	4.7.4.2
Maintenance aging	3.6	4.7.2
Temperature cycling	3.7	4.7.3
Coupling	3.8	4.7.4
Durability	3.9	4.7.5
Altitude immersion (qualification only)	3.10	4.7.6
Insulation resistance at ambient temperature	3.11.1	4.7.7.1
Dielectric withstanding voltage at sea level	3.12	4.7.8.1
Insert retention	3.13	4.7.9
Shell-to-shell conductivity	3.23	4.7.19
Salt spray (corrosion)	3.14	4.7.10
Coupling force/torque	3.8	4.7.4
Shell-to-shell conductivity	3.23	4.7.19
Decoupling rate	3.8.3	4.7.4.1
Electrical engagement	3.15	4.7.11
Post test examination	3.39 and 3.40	4.7.36

MIL-C-83538

TABLE VI Qualification and Group C periodic test - Continued

Inspection	Requirement paragraph	Test paragraph
<u>Group 2</u>		
Visual and mechanical examination	3.1, 3.3, 3.4, 3.5, 3.39, and 3.40	4.7.1
Gauge location	3.16	4.7.12
Gauge retention	3.17	4.7.13
Maintenance aging	3.6	4.7.2
Contact retention	3.18	4.7.14
Altitude (low temperature)	3.19	4.7.15
Insulation resistance at ambient temperature	3.11.1	4.7.7.1
Dielectric withstanding voltage at sea level	3.12	4.7.8.1
Temperature cycling	3.7	4.7.3
Coupling	3.8	4.7.4
Insulation resistance at elevated temperature	3.11.2	4.7.7.2
Dielectric withstanding voltage at sea level	3.12	4.7.8.1
Dielectric withstanding voltage at altitude	3.12	4.7.8.2
Durability	3.9	4.7.5
Accessory thread strength	3.20	4.7.16
Vibration (qualification only)	3.21	4.7.17
Shock	3.22	4.7.18
Shell-to-shell conductivity	3.23	4.7.19
High temperature exposure (qualification only)	3.34	4.7.31
Humidity	3.24	4.7.20
Insulation resistance at ambient temperature	3.11	4.7.7.1
Dielectric withstanding voltage at sea level	3.12	4.7.8.1
Contact retention	3.18	4.7.14
Post test examination	3.39 and 3.40	4.7.36
<u>Group 3</u>		
Visual and mechanical examination	3.1, 3.3, 3.4, 3.5, 3.39, and 3.40	4.7.1
Durability	3.9	4.7.5
Shell spring finger forces	3.25	4.7.21
Shell-to-shell conductivity	3.23	4.7.19
Salt spray (corrosion)	3.14	4.7.11
Insertion loss	3.27	4.7.23
Voltage standing wave ratio	3.28	4.7.24
Shell-to-shell conductivity	3.23	4.7.19
EMI shielding	3.26	4.7.22
Post test examination	3.39 and 3.40	4.7.36
<u>Group 4</u>		
Visual and mechanical examination	3.1, 3.3, 3.4, 3.5, 3.39, and 3.40	4.7.1
Ozone exposure	3.29	4.7.25
Insulation resistance at ambient temperature	3.11.1	4.7.7.1
Dielectric withstanding voltage	3.12	4.7.8.1
Fluid immersion	3.31	4.7.27
Dielectric withstanding voltage at sea level	3.12	4.7.8.1
Coupling	3.8	4.7.4
Post test examination	3.39 and 3.40	4.7.36

MIL-C-83538

TABLE VI. Qualification and Group C periodic test - Continued.

Inspection	Requirement paragraph	Test paragraph
<u>Group 5</u>		
Visual and mechanical examination	3.1, 3.3, 3.4, 3.5, 3.39, and 3.40	4.7.1
Retention system fluid immersion	3.31.1	4.7.28
Contact retention	3.18	4.7.14
Post test examination	3.39 and 3.40	4.7.36
<u>Group 6</u>		
Visual and mechanical examination	3.1, 3.3, 3.4, 3.5, 3.39, and 3.40	4.7.1
Contact walkout	3.32	4.7.29
Installing/removal tool abuse (qualification only)	3.33	4.7.30
High temperature exposure with contact loading	3.34.1	4.7.31.1
Insert retention	3.13	4.7.9
Post test examination	3.39 and 3.40	4.7.36
<u>Group 7</u>		
Visual and mechanical examination	3.1, 3.3, 3.4, 3.5, 3.39, and 3.40	4.7.1
Dielectric withstanding voltage at sea level	3.12	4.7.8.1
Electrolytic erosion	3.35	4.7.32
Salt spray (corrosion)	3.14	4.7.10
Coupling	3.8	4.7.4
Post test examination	3.39 and 3.40	4.7.36
<u>Group 8</u>		
Visual and mechanical examination	3.1, 3.3, 3.4, 3.5, 3.39, and 3.40	4.7.1
Ice and freezing rain	3.36	4.7.36
Sand and dust	3.37	4.7.37
Coupling	3.8	4.7.4
Post test examination	3.39 and 3.40	4.7.36
<u>Group 9.</u>		
Visual and mechanical examination	3.1, 3.3, 3.4, 3.5, 3.39, and 3.40	4.7.1
3.34.3		
Post launch temperature	3.39 and 3.40	4.7.31.3
Post test examination		4.7.36
<u>Group 10</u>		
Visual and mechanical examination	3.1, 3.3, 3.4, 3.5, 3.39, and 3.40	4.7.1
Acoustic noise	3.30	4.7.26
Post test examination	3.39 and 3.40	4.7.36

MIL-C-83538

4.4.4 Retention of qualification To retain qualification, the contractor shall forward a report at least every 12 months to the qualifying activity. The qualifying activity shall establish the reporting date. The report shall consist of the following:

- a. A summary of the results of the test performed for groups A and B inspection indicating, as a minimum, the number of lots that have passed and the number that have failed. The results of tests of all reworked lots shall be identified and accounted for.
- b. A summary of the results of tests performed for group C inspection including the number and mode of failures. The summary shall include results of all group C inspection tests performed and completed during the reporting period. If the summary of the test results indicates nonconformance with specification requirements, and corrective action acceptable to the qualifying activity has not been taken, action may be taken to remove the failing product from the qualified products list. Failure to submit the report within 30 days after the end of each reporting period may result in loss of qualification for the product. In addition to the periodic submission of inspection data, the contractor shall immediately notify the qualifying activity if at any time during the reporting period that the inspection data indicates failure of the qualified product to meet the requirements of this specification.

In the event that no production occurred during the 12-month reporting period, a report shall be submitted certifying that the company still has capabilities and facilities necessary to produce the item. If during two consecutive reporting periods there has been no production, the manufacturer may be required, at the discretion of the qualifying activity, to submit the products (a representative product of each connector) to testing in accordance with qualification inspection requirements.

4.5 Quality conformance inspections

4.5.1 Inspection of product for delivery. Inspection of product for delivery shall consist of groups A and B inspections.

4.5.1.1 Group A inspection Group A inspection shall consist of the visual and mechanical inspections specified in table VIII. The documentation requirements of MIL-STD-1344 do not apply.

TABLE VIII Group A inspection 1/

Inspection	Requirement paragraph	Test paragraph
Visual inspection 2/	3.1, 3.3, 3.4, 3.5, 3.39, and 3.40	4.5.1.1.1
Critical examination 2/ 3/	3.1, 3.2.2, and 3.3	4.5.1.1.2
Insulation resistance at ambient temperature 2/ 3/ 4/	3.11.1	4.7.7.1
Dielectric withstanding voltage at sea level 2/ 3/ 4/	3.12	4.7.8.1

1/ Contacts shipped with connectors shall be from lots that have met the requirements of MIL-C-39029.

2/ 100 percent inspection

3/ The contractor may use in-process controls for this requirement.

4/ Test between adjacent contacts and between two peripheral contacts and the shell.

4.5.1.1.1 Visual examination (group A inspection) Each connector and accessory shall be visually examined for completeness, workmanship, and identification requirements. Attention shall be given to those assemblies that require a gasket to determine the condition of the gasket. Gaskets missing, twisted, buckled, kinked, or damaged in any way shall be cause for rejection. Each connector shall be visually inspected for the presence of compound between wire termination end of insert and shell.

MIL-C-83538

4.5.1.1.2 Critical examinations (group A inspection). The following dimensions and features shown on the pertinent military standard are considered critical

- a. Mating diameters (see 3.1) (maximum on plugs, minimum on receptacles)
- b. Key or keyway positions
- c. Registration of grommet and insert markings (hole pattern between the grommet and the front face of the insert)

4.5.1.2 Group B inspection. Group B inspection shall consist of the inspections specified in table X in the order shown and shall be made on sample units which have been subjected to and have passed the group A inspection. For group B inspection, the documentation and standard test conditions of MIL-STD-1344 do not apply.

4.5.1.2.1 Sampling plan (group B inspection). A sample size shall be randomly selected in accordance with table IX. If one or more defects are found the lot shall be rescreened and defects removed. A new sample in accordance with table VIII shall then be randomly selected. If one or more defects are found in the second sample the lot shall be rejected and shall not be supplied to this specification.

4.5.1.2.2 Lot definition (group B inspection). The production lot definition of MIL-STD-790 is further defined as follows:

- a. A production lot consists of all connectors covered under one military specification or standard, manufactured from the specified raw materials, processed under the same specification and procedures, produced by the same type of equipment, and submitted for inspection at one time. Each production lot of assembled connectors shall be a group identified by a common manufacturing record through all significant assembly operations.
- b. Traceability of connectors to specific physical/chemical test reports of incoming raw material is not required.
- c. Common manufacturing records and traceability shall begin with the start of connector assembly.

TABLE IX. Sampling plans

Lot size	Sample size
1 to 13	100 percent
14 to 150	13 units
151 to 280	20 units
281 to 500	29 units
501 to 1,200	34 units
1,201 to 3,200	42 units

TABLE X Group B inspection

Inspection	Requirement paragraph	Test paragraph	Number of samples
Visual and mechanical examination ^{1/}	3.1, 3.3, 3.4, 3.5,	4.7.1	See table IX
Shell spring finger forces (receptacles with spring fingers only) ^{1/}	3.39, and 3.40	4.7.21	
Coupling	3.25	4.7.4	
	3.8		

^{1/} The contractor may use in-house controls for this requirement

MIL-C-83538

4.5.1.2.3 Disposition of sample units Sample units which have passed all of group B inspections may be delivered on the contract or purchase order if the lot is accepted and the sample units are still within specified tolerances

4.5.2 Periodic inspection Periodic inspection shall consist of group C inspection. Except where the results of this inspection show noncompliance with the applicable requirements (see 4.5.2.1.4), delivery of products which have passed groups A and B inspections shall not be delayed pending the results of this periodic inspections

4.5.2.1 Group C inspection (periodic test) Periodic tests shall be performed on a 12-month and 24-month basis, beginning with the 12-month periodic test, which must be accomplished within this period after notification of qualification and alternating thereafter with the 24-month periodic test. Samples submitted to either of these periodic tests shall have passed groups A and B inspections

4.5.2.1.1 Twelve-month periodic test The following tests shall be performed as follows:

- a. On two mating sets of the combined launcher receptacle, buffer plug and the store receptacle in regular production during that period - Humidity in accordance with 4.7.20.
- b. On one mating set of the combined launcher receptacle, buffer plug and store receptacle - High temperature exposure with contact loading in accordance with 4.7.31.1 except that the time period shall be 250 hours
- c. On two mating sets of the combined launcher receptacle, buffer plug and store receptacle, one set being subjected to each of the specified fluids - Fluid immersion shall be in accordance with 4.7.27 except that the fluids shall be
 1. MIL-T-5624, JP5, sample 7, table XIII
 2. Hydraulic fluid, sample 4, table XIII (M2-V chervron oil, or equivalent).
- d. On one launcher receptacle, buffer plug and store receptacle conduct the salt spray test of 4.7.11.

4.5.2.1.2 Twenty-four month periodic tests Every 24 months, mating connector sample units shall be selected and tested in accordance with the following

- a. Three mating sets of the combined launcher receptacle, buffer plug and store receptacle shall be provided. One set shall be fully wired with the applicable wire listed in maximum diameter column of table V and subjected to the applicable tests of table VI, group 1. The remaining sample sets shall be fully wired with the applicable wire listed in minimum diameter column of table V and subjected to the applicable tests of table VI, group 2
- b. On one launcher receptacle, buffer plug and store receptacle conduct the salt spray test of 4.7.10

4.5.2.1.3 Failures If one or more sample units fail to pass group C inspection, the sample shall be considered to have failed

4.5.2.1.4 Noncompliance If a sample fails to pass group C inspection, the manufacturer shall take corrective action on the materials or processes or both, as warranted, and on all units of product which are to be corrected and which were manufactured with essentially the same materials and processes, and which are considered subject to the same failure. Acceptance and shipment of the product shall be discontinued until corrective action acceptable to the qualifying activity has been taken. After the corrective action has been taken, group C inspection shall be repeated on additional sample units (all inspections, or the inspection which the original sample failed, at the option of the qualifying activity). Groups A and B inspections may be reinstated, however, final acceptance shall be withheld until the group C reinspection has shown that corrective action was successful. In the event of failure after reinspection, information concerning the failure shall be furnished to the cognizant inspection activity and the qualifying activity

4.5.3 Failures of groups A, B, or C Lots which fail groups A, B, or C and are not resubmitted for testing or failed resubmission shall not be shipped and the "JAN" marking shall be removed within 30 days

MIL-C-83538

4.6 Inspection of packaging. The sampling and inspection of the preservation, packaging, and container marking shall be in accordance with the requirements of MIL-C-55330.

4.7 Methods of inspection

4.7.1 Visual and mechanical examination Connectors, accessories, and piece parts shall be visually and mechanically examined to ensure conformance with the specification and the applicable military standards (see 3.1, 3.3, 3.4, 3.5, 3.39, and 3.40). The contractor may use in process controls to satisfy these requirements.

4.7.2 Maintenance aging (see 3.6). Connectors shall be tested in accordance with method 2002 of MIL-STD-1344. The following detail shall apply: Installing/removal tool shall be in accordance with MIL-I-81969/8 and MIL-I-81969/14. A minimum of 20 percent, but not less than three contacts of each connector shall be tested. Fifty percent of maintenance aging shall be performed with M81969/8 tools and fifty percent with M81969/14 tools. There shall be no lubricant used during this test.

4.7.3 Temperature cycling (see 3.7). Mated connectors shall be subjected to the temperature cycling of MIL-STD-1344, method 1003, test condition A, except that steps 2 and 4 shall be of 2 minutes maximum duration. The temperature of step 1 shall be $-65^{\circ}\text{C} \pm 0^{\circ}\text{C}$, -5°C , and the temperature of step 3 shall be $+200^{\circ}\text{C}$. A suitable fixture, approved by the qualifying activity, shall apply a mating force of 289 newtons (65 pounds) $\pm 10\%$ to hold the connector pair together (see figure 6). A suitable fixture, approved by the qualifying activity, shall apply a mating force of 289 newtons (65 pounds) $\pm 10\%$ to hold the connector pair together (see figure 14).

4.7.4 Coupling (see 3.8). For qualification testing, mating connectors shall be coupled and uncoupled. The forces or torques which must be applied to facilitate full coupling and uncoupled shall be measured and recorded.

4.7.4.1 Coupling torque of bayonet coupled component (see 3.8.1). For qualification testing, mating connectors shall be coupled and uncoupled. The torques which must be applied to facilitate full coupling and uncoupling shall be as specified in 3.8.1.

4.7.4.2 Coupling force (see 3.8.2). For qualification testing, mating connectors shall be coupled and uncoupled. The forces which must be applied to facilitate full coupling and uncoupling shall be as specified in 3.8.2.

4.7.4.3 Decoupling rate (see 3.8.3). Using an appropriate test fixture that can apply up to a 320 newton force to the launcher receptacle attachment points (via mechanical or electromechanical mechanism), measure and record the distance at which electrical and physical separation occurs and the time at which this separation occurs.

4.7.4.4 Self-alignment (see 3.8.4). The connector shall be tested for compliance with the alignment provisions of 3.8.4 by mounting the launcher receptacle with attached buffer plug in a floating mount assembly and mounting the store receptacle in an adjustable but fixed mount assembly. The store receptacle and its mount shall be adjusted to misalign the centerline of the receptacle from the centerline of the launcher receptacle by the values identified in 3.8.4. The misalignments shall be cumulative.

4.7.5 Durability (see 3.9). The wired, assembled launcher receptacles (with buffer plug) and store receptacles shall be mated and unmated 500 cycles at a rate of 300 cycles per hour maximum. The mating and unmating shall be accomplished so that the launcher receptacle/buffer plug assembly and store receptacle are completely separated during each cycle. The mating shall use a suitable blind-mate actuation mechanism such that the alignment pins of the connectors are exercised.

4.7.6 Altitude immersion (qualification only) (see 3.10) Mated connectors shall be tested in accordance with method 1004 of MIL-STD-1344. The following details shall apply:

- a. Service rating N shall apply.
- b. All wire ends shall be located within the chamber and exposed to the chamber atmosphere but not submerged or sealed.

MIL-C-83538

- c. At the end of the third cycle, while the connectors are still submerged in the solution, the insulation resistance at ambient temperature, shall be measured as specified in 4.7.7.1 and the dielectric withstanding voltage test shall be performed as specified in 4.7.8.1
- d. A suitable fixture, approved by the qualifying activity, shall apply a mating force of 289 newtons (65 pounds) $\pm 10\%$ to hold the connector pair together (see figure 14)

4.7.7 Insulation resistance

4.7.7.1 Insulation resistance at ambient temperature (see 3.11.1). Unmated store receptacle and combined launcher receptacle/buffer plug connectors shall be tested as specified in method 3003 of MIL-STD-1344. The following details and exceptions shall apply.

- a. For lot acceptance testing, where it is undesirable to install actual contacts in connectors, simulated contacts and special techniques may be used in performing this test.
- b. The tolerance on the applied voltage shall be 10 percent.
- c. Connectors shall be mated when testing after altitude immersion, humidity and altitude (low temperature).

4.7.7.2 Insulation resistance at elevated temperature (see 3.11.2). Unmated store receptacle and combined launcher receptacle/buffer plug connectors shall be tested as specified in method 3003 of MIL-STD-1344. The following details and exceptions shall apply.

- a. The tolerance on the applied voltage shall be ± 10 percent.
- b. Test temperature of $+200^{\circ}\text{C} +5^{\circ}\text{C}$, -0°C , for 30 minutes
- c. Measurements shall be made while the connectors are still in the chamber at the specified temperature.

4.7.8 Dielectric withstanding voltage (see 3.12)

4.7.8.1 Dielectric withstanding voltage at sea level. Wired, unmated store receptacle and combined launcher receptacle/buffer plug connectors shall be tested in accordance with method 3001 of MIL-STD-1344. Connectors shall be mated when testing after altitude immersion, humidity, and altitude (low temperature). The following details and exceptions shall apply

- a. The magnitude of the test voltage shall be as specified in table XI.
- b. Fifty percent of the contacts available shall be tested, but in no case shall less than six dielectric withstanding voltage readings be taken. If the number of contacts is three or less, all contacts shall be tested. The test voltage shall be applied between each wired contact, and each adjacent contact, and the shell.
- c. The test voltage shall be maintained at the specified value for 2 seconds minimum.
- d. For quality conformance, simulated contacts and special techniques may be used

TABLE XI. Test voltages, ac rms, 60 Hz.

Altitude	Service rating N	
	Mated	Unmated
Sea level	1,000	1,000
15,240 meters (50,000 feet)	600	400
21,336 meters (70,000 feet)	600	260
30,480 meters (100,000 feet)	600	200

MIL-C-83538

4.7.8.2 Dielectric withstanding voltage at altitude Mated connectors and unmated connector halves with pin contacts shall be tested in accordance with method 3001 of MIL-STD-1344. The following details and exceptions shall apply:

- a The magnitude of the test voltages shall be as specified in table XI.
- b Fifty percent of the contacts available shall be tested, but in no case shall less than six dielectric withstanding voltage readings be taken. If the number of contacts is three or less, all contacts shall be tested. The test voltage shall be applied between each wired contact and each adjacent contact and the shell.
- c The test voltage shall be maintained at the specified value for 2 seconds minimum.
- d The leads of all test circuits shall be brought out through the walls of the chamber. There shall be no wire splices inside the chamber. The wire ends of all leads shall be unsealed.
- e The chamber shall be evacuated to each of the specified altitude pressure equivalents listed below.

<u>Altitude</u>	<u>Equivalent pressure</u>
15,240 meters (50,000 feet)	87 torr
21,336 meters (70,000 feet)	33 torr
30,480 meters (100,000 feet)	8 torr

4.7.9 Insert retention (see 3.13) Unmated connectors shall be tested in accordance with method 2010 of MIL-STD-1344. The following details and exceptions shall apply:

- a Force to be applied: 17.5 ± 9 newtons per square mm (100 \pm 5 pounds per square inch) with a 4.4 newtons (25 pounds) minimum force.
- b Connectors may be wired.

4.7.10 Salt spray (corrosion) (see 3.14). The wired, store receptacle and combined launcher receptacle/buffer plug shall be mated and unmated 50 cycles at a rate of 300 cycles per hour maximum. The mating and unmating shall be accomplished so that the connector assembly are completely separated during each cycle. The connectors shall then be subjected to the salt spray test in accordance with method 1001 of MIL-STD-1344. The following details and exceptions shall apply:

- a. For connectors that have already been subjected to a mating/unmating test, the 50 mating/unmating cycles prior to salt spray are not required.
- b. The pretest mating/unmating cycles shall use a suitable blind-mate actuation mechanism.
- c. For group 7 test only, perform 450 mating/unmating cycles after salt spray exposure.
- d. The connectors shall be tested for 452 hours mated, followed by 48 hours unmated.
- e. The connectors shall not be mounted but shall be suspended from the top of the chamber using waxed twine or string, glass rods, or glass cord.
- f. Wire ends must be protected to prevent salt migration.
- g. A suitable fixture, approved by the qualifying activity, shall apply a mating force of 289 newtons (65 pounds) \pm 10% to hold the connector pair together (see figure 14).

4.7.11 Electrical engagement (see 3.15) The combined launcher receptacle/buffer plug and store receptacle shall be wired so it provides a complete series circuit through all contacts of the mated connector. A suitable power source and indicator shall be provided such that the earliest point at which the circuit is completed, during normal connector mating, can be established.

MIL-C-83538

4.7.11.1 Electrical engagement-store receptacle to buffer plug Connector halves shall be slowly mated by normal mating means until first indication of a completed circuit is observed. Means shall be provided to assure that electrical contact is made between the pin and the spring of the socket contact, rather than the hood of the socket contact. The mating operation shall be held at this point and the overall connector length shall be measured from solid reference points on the connector halves. The mating operation shall then be continued until the connector halves are in the completely mated position by applying a holding force of 289 newtons (65 pounds) $\pm 10\%$. A second overall length measurement shall then be taken from the same reference points. The difference of these two measurements shall be not less than that specified in 3.15. Both the outer shield and inner conductor circuits shall be included in the test of shielded contacts.

4.7.11.2 Electrical engagement-launcher receptacle to buffer plug Connector halves shall be slowly mated by normal mating means until first indication of a completed circuit is observed. Means shall be provided to assure that electrical contact is made between the pin and the spring of the socket contact, rather than the hood of the socket contact. The mating operation shall be held at this point and the overall connector length shall be measured from solid reference points on the connector halves. The mating operation shall then be continued until the connector halves are in the completely mated position. A second overall length measurement shall then be taken from the same reference points. The difference of these two measurements shall be not less than that specified in 3.15. Both the outer shield and inner conductor circuits shall be included in the test of shielded contacts.

4.7.12 Gauge location (see 3.16). Applicable test gauges, conforming to figure 4 shall be installed in three randomly selected cavities in each connector. With each test gauge fully seated back against its contact retention device, the axial location of the front end of each gauge shall be measured relative to the reference point indicated in 3.1, as applicable.

4.7.13 Gauge retention (see 3.17). Applicable test gauges conforming to figure 5 shall be installed in three randomly selected cavities in each connector. The axial load specified in 4.7.14 shall be applied to individual test gauges in both directions. The load shall be applied at a rate of approximately 4.45 newtons (1 pound) per second until the specified load has been reached. Gauge displacement shall be measured with respect to the connector shell after an initial load of 8.9 newtons (2 pounds) has been applied to assure that all slack has been taken up.

4.7.14 Contact retention (see 3.18) Unless otherwise specified, contacts shall be tested to procedures I and II.

4.7.14.1 Procedure I The contact retention shall be tested as specified in method 2007 of MIL-STD-1344. The following details and exceptions shall apply:

- a Number of samples. The test shall be performed on 20 percent of the contact complement; but not less than three contacts in each connector half.
- b Applied axial load: Preload to 13.6 newtons maximum (3 lbs). Apply load as specified in table XII.
- c Special requirements: Where the test sequence required maintenance aging prior to contact retention, the contacts which were subjected to maintenance aging shall also be selected for contact retention.
- d Axial direction. The applicable forces shall be applied along the longitudinal axis of individual contacts in the direction tending to displace the contacts to the rear.
- e Only the contacts to be tested need be installed in the connector.

4.7.14.2 Procedure II The contact retention shall be tested as specified in method 2007 of MIL-STD-1344. The following details and exceptions shall apply:

- a 4.7.14.1a through 4.7.14.1c apply.
- b Axial direction. Same as 4.7.14.1d, except the direction shall tend to displace the contacts to the front.
- c Only the contacts to be tested need be installed in the connector.

MIL-C-83538

TABLE XII. Contact retention

Contact	Load ± 10 percent	
	Newtons	Pounds
20	67	15
16	111	25
12 coaxial	111	25
8 twinaxial	111	25

4.7.15 Altitude (low temperature) (see 3.19). Wired, mated, assembled connectors shall be subjected to the test specified in method 1011 of MIL-STD-1344. The following details shall apply:

- a. No wire ends or splices inside the chamber.
- b. Dielectric withstanding voltage test to be performed after return to ambient conditions shall be in accordance with 4.7.8.1.
- c. Insulation resistance test to be performed at 30,480 meters (100,000 feet) at -65°C and shall be in accordance with 4.7.7.1.
- d. A suitable fixture, approved by the qualifying activity, shall apply a mating force of 289 newtons (65 pounds) $\pm 10\%$ to hold the connector pair together (see figure 14).

4.7.16 Accessory thread strength (see 3.20). The combined mated launcher receptacle, buffer plug, and store receptacle shall be mounted as in normal service to a rigid panel. The torque wrench shall be attached as shown on figure 7. After mating the connectors, a torque shall be applied to the accessory end of the launcher receptacle at a rate of approximately 44.5 newtons (10 pounds) per second until the required torque is achieved. The applied load shall be held for 1 minute, then the load shall be released. The test shall then be repeated on the accessory end of the store receptacle.

4.7.17 Vibration (qualification only) (see 3.21). Wired and mated connectors shall be subjected to the applicable test(s) specified. All contacts shall carry a test current of 100 milliamperes maximum and shall be continuously monitored for discontinuities throughout the test. A detector capable of detecting any discontinuities in excess of 1 microsecond shall be used. An accessory load fixture in accordance with figure 8 shall be attached to the launcher receptacle and store receptacle during vibration. A suitable fixture, approved by the qualifying activity, shall apply a mating force of 289 newtons (65 pounds) $\pm 10\%$ to hold the connector pair together (see figure 14).

4.7.17.1 Random vibration. Connectors shall be subjected to the test specified in method 2005 of MIL-STD-1344. The following details shall apply:

- a. Test condition VI. Letter "J"
- b. Vibration to be conducted at 200°C .
- c. Duration shall be 8 hours in a longitudinal direction and 8 hours in a perpendicular direction for a total of 16 hours.

4.7.17.2 Random vibration. Connectors shall be subjected to the test specified in method 2005 of MIL-STD-1344. The following details shall apply:

- a. Test condition V. Using the vibration envelope shown on figure 9.
- b. Vibration to be conducted at ambient temperature.
- c. Duration shall be 8 hours in the longitudinal direction and 8 hours in a perpendicular direction for a total of 16 hours.
- d. Figure 8 test accessory shall not be required.

MIL-C-83538

4.7.18 Shock (see 3.22) Wired and mated connectors shall be subjected to the applicable test specified. The mated connectors shall be mounted in a simulated rack assembly fixture. Connectors shall be monitored for any discontinuities. A detector capable of detecting all discontinuities in excess of 1 microsecond shall be used. A suitable fixture, approved by the qualifying activity, shall apply a mating force of 289 newtons (65 pounds) $\pm 10\%$ to hold the connector pair together (see figure 14).

4.7.18.1 Standard shock Connectors shall be subjected to the test specified in method 2004 of MIL-STD-1344. The following details shall apply:

- a. The pulse shall be an approximate half sine wave of 300 g's ± 15 percent magnitude with a duration of 3 ± 1 milliseconds.
- b. The wire bundle shall be clamped to fixed points at least 203.2 mm (8 inches) from the rear of the connector.

4.7.19 Shell to shell conductivity (see 3.23) Mated connectors shall be subjected to the test specified in MIL-STD-1344, method 3007. A suitable fixture, approved by the qualifying activity, shall apply a mating force of 289 newtons (65 pounds) $\pm 10\%$ to hold the connector pair together (see figure 14).

4.7.20 Humidity (see 3.24) Wired, mated connectors shall be subjected to the humidity test specified in method 1002 of MIL-STD-1344. The following details and exceptions shall apply:

- a. Test condition letter: Type II.
- b. The mated connectors shall be mounted in a vertical position.
- c. Step 7a shall be performed during the last 5 cycles.
- d. Three hours minimum after the start of step 7a during the final cycle and while the connectors are still subjected to high humidity, the insulation resistance shall be measured when the chamber temperature reaches $20^{\circ}\text{C} \pm 5^{\circ}\text{C}$ and condensation is observed on the connector.
- e. For qualification testing, insulation resistance readings shall be made on a minimum of 50 percent of the circuits. Outer circuits shall be measured to the connector shell.
- f. A suitable fixture, approved by the qualifying activity, shall apply a mating force of 289 newtons (65 pounds) $\pm 10\%$ to hold the connector pair together (see figure 14).

4.7.21 Shell spring finger forces (see 3.25) Plugs shall be completely mated and unmated 10 times with counterpart receptacles less coupling pins (if applicable) and inserts. On the mating of the first cycle, the forces necessary to engage the connectors shall be within the values specified in 3.25. On the unmating of the last cycle, the forces necessary to separate the connectors shall be within the values specified in 3.25. When measuring the engagement and separation forces, the axial loads shall be applied at a displacement rate of 12.70 mm (5 inch) per minute.

4.7.22 EMI shielding (see 3.26)

4.7.22.1 EMI shielding (from 100 Hz to 1 GHz only) The EMI shielding effectiveness of mated connectors with EMI backshells (backshells may be soldered to the connector) shall be measured in a triaxial radio frequency leakage fixture as shown on figure 10. The EMI leakage from the conductor inside the connector in the same inner coaxial line into the outer coaxial line shall be measured at the frequencies specified in table III within a frequency accuracy of ± 5 percent. The level of detected signal power shall be indicated by a tunable radio frequency field intensity meter isolated from the test circuit by a 3 to 10 dB pad. Care shall be taken to ensure that the signal is a result of EMI leakage from within the mated connector and not due to a faulty termination inside the fixture. All terminations inside the fixture, whether to the EMI backshells or between internal conductors, shall have a leakage at least 10 dB less than the test requirements. The signal source shall be set to the desired frequency. The signal shall be fed through a 3 to 10 dB isolation pad to a parallel circuit consisting of a coaxial switch (DPDT) so connected that the signal can be manually or electronically fed alternately to the fixture and to a variable 100 dB reference attenuator. The attenuator shall be adjustable in 1 dB steps and calibrated to ± 3 dB.

MIL-C-83538

- a. The inserts may be removed from the connectors under test or the contacts removed and a hole drilled through the inserts to accommodate a center conductor of suitable geometry to provide a good 50 ohms impedance match with the inside diameter of the mated connector shells and EMI backshells. Tapered transition may be used to provide a means of changing diameters without introducing significant discontinuities in the line. The maximum VSWR in the inner coaxial line shall be 1.5. The outer shell of the test fixture shall be so constructed as to provide a good 50 ohms impedance match with the outside diameter of the mated connector shells, coupling ring, and EMI backshells. The maximum VSWR of the outer coaxial line shall be 1.5.
- b. A sliding circumferential short shall be positioned behind the connector on the signal input end of the fixture to provide for tuning the outer coaxial line for maximum output at each test frequency. The allowable travel of this short shall be greater than one-half wave length at the lowest test frequency of 1.5 meters minimum for 100 MHz. The inner coaxial line shall be terminated in a fixed 50-ohm load impedance behind the connector at the output end of the fixture.
- c. The connectors used to couple together the various elements of the test system shall be of a low-leakage type which have a nominal impedance of 50 ohms, a VSWR of less than 1.5, and a minimum leakage attenuation of 100 dB. The output impedance of the signal source and the input impedance of the detector shall be nominally 50 ohm with a maximum VSWR of 1.5. The input and output VSWR of the standard attenuator shall be less than 1.5 in the 20 to 100 dB range.
- d. The relative signal level in the variable attenuator shall be equaled to the signal level through the leakage fixture by adjusting the attenuator. The signal loss in the fixture can then be read from the setting on the variable attenuator.

4.7.22.2 EMI shielding (from 1 GHz to 10 GHz). The EMI shielding effectiveness of mated connectors with EMI backshells shall be measured using the mode-stirred technique specified in method 3008 of MIL-STD-1344.

4.7.23 Insertion loss (see 3.27).

4.7.23.1 Contact resistance. Connectors shall be tested in accordance with the contact resistance test method of MIL-C-39029. The following details and exceptions shall apply:

- a. The test shall be conducted on the mated set of launcher receptacle, buffer plug, and store receptacle.
- b. The total measured maximum resistance through the combined three units shall be 2.0 times the limits of MIL-C-39029 for the applicable size contacts.
- c. A suitable fixture, approved by the qualifying activity, shall apply a mating force of 289 newtons (65 pounds) $\pm 10\%$ to hold the connector pair together (see figure 14).

4.7.23.2 RF insertion loss. Wired, mated set of launcher receptacle, buffer plug and store receptacle shall be tested as shown on figure 11. Insertion loss of a mated connector set is defined as the increase of a loss due to insertion of mated connectors in a cable; this includes the reflection losses to the cable and the dissipating losses in the pair. First insert cable assembly number 1 and tune out its input VSWR by means of tuner number 4 and balance setup. Then insert the cable assembly number 2 which includes the connector set under test. With tuner number 4 in the same position and the electrical length of the cable assembly the same as that of number 1, record increase of insertion loss; add to this as a correction, the cable loss of the removed section due to the length $\Delta L1 + \Delta L2$ at this frequency. The sum of the increase and the correction is the insertion loss of the connector set. The following details shall apply:

- a. The high bandwidth 1 and 2 contacts shall be terminated to RG316 cable and the high bandwidth 3 and 4 contacts shall be terminated to RG179 cable.
- b. The high bandwidth 1 contact shall be tested by sweeping from 20 Hz to 1.6 GHz with a 50-ohm reference load.
- c. The high bandwidth 2 contact shall be tested by sweeping from 20 Hz to 20 MHz with a 50-ohm reference load.

MIL-C-83538

- d The high bandwidth 3 and 4 contacts shall be tested by sweeping from 20 Hz to 20 MHz with a 75-ohm reference load.
- e For frequencies from 500 MHz to 1.6 GHz, the measured insertion loss shall not exceed $0.11 \text{ dB} \times \sqrt{F}$, where F is the test frequency in GHz. For frequencies below 500 MHz, the insertion loss shall not exceed 0.12 dB.
- f For frequencies from 20 Hz to 20 MHz, the insertion loss shall not exceed 0.20 dB.
- g A suitable fixture, approved by the qualifying activity, shall apply a mating force of 289 newtons (65 pounds) $\pm 10\%$ to hold the connector pair together (see figure 14)

4.7.24 Voltage standing wave ratio (see 3.28). Wired, mated connectors shall be subjected to the following VSWR tests.

- a. Conduct the test on a mated set of launcher receptacle, buffer plug, and store receptacle units
- b High bandwidth 1 and 2 contacts shall be tested with RG316 cable and a 50-ohm reference load High bandwidth 3 and 4 contacts shall be tested with RG179 cable and a 75-ohm reference load.
- c. After performing a 50-ohm ± 1 -port calibration of the vector network analyzer, set up the test configuration of figure 12 for the connector set under test. Set the network analyzer starting frequency at 50 MHz maximum and the stopping frequency at 3.0 GHz minimum.
- d Display the linear magnitude of the low pass impulse reflection response (time domain) of the figure 12 test setup (inverse fourier transform of the frequency domain data).
- e Gate out all reflection contributors beyond adapter 1 (see figure 12).
- f Fourier transform the gated impulse reflection response back into the frequency domain and verify that adapter 1 VSWR is less than 1.20 over the frequency range selected in step "c" above.
- g. Return the network analyzer to the low pass impulse response (time domain) mode and remove the gate of step "e" above
- h Remove all residual reflection contributors by centering (± 1 nanosecond) a new gate at the midpoint between the mated connector set. Set this new gate width to a value higher than 20.0 nanoseconds.
- i. Fourier transform the gated impulse reflection response back into the frequency domain.
- j Verify that the displayed resulting transformed return loss (or equivalent reflection coefficient) complies with the VSWR limits specified in 3.28.
- k A suitable fixture, approved by the qualifying activity, shall apply a mating force of 289 newtons (65 pounds) $\pm 10\%$ to hold the connector pair together (see figure 14).

4.7.25 Ozone (3.29). Wired, mated connectors shall be subjected to the test specified in method 1007 of MIL-STD-1344 A suitable fixture, approved by the qualifying activity, shall apply a mating force of 289 newtons (65 pounds) $\pm 10\%$ to hold the connector pair together (see figure 14).

4.7.26 Acoustic noise (see 3.30) Wired, mated connectors shall be subjected to the test of MIL-STD-810, method 515 with the following details and exceptions shall apply

- a The acoustic environment shall be as specified in method 515 for procedure II, category I with L_0 of 160 dB, f_0 of 1,000 hertz and a duration of 30 hours
- b All connector contacts shall be wired in series and connected to a monitoring instrument capable of detecting discontinuities in excess of 1 microsecond duration
- c A suitable fixture, approved by the qualifying activity, shall apply a mating force of 289 newtons (65 pounds) $\pm 10\%$ to hold the connector pair together (see figure 14).

MIL-C-83538

4.7.27 Fluid immersion (see 3.31). Connector samples shall be subjected to the test specified in method 1016 of MIL-STD-1344 (one sample per fluid as referenced in table XIII) Following the fluid immersion cycles, the connectors shall be tested for coupling force/torque as specified in 4.7.4, decoupling rate as specified in 4.7.4.3 and dielectric withstanding voltage at sea level as specified in 4.7.8.1 within 3 hours.

4.7.28 Retention system fluid immersion (see 3.31.1) Unmated connectors with contacts removed shall be immersed in the fluids listed in table XIII (one sample per fluid) for 2 hours at room temperature. After removal, excess fluid shall be drained from the connectors for 4 hours and the contacts reinstalled. Following the test, the connectors shall be subjected to contact retention as specified in 4.7.14.

TABLE XIII. Test fluids

Sample number	Test fluid (method 1016 of MIL-STD-1344)
1	d
2	e
3	a
4	b
5	f
6	g
7	c
8	l
9	h
10	i

4.7.29 Contact wickout (see 3.32). Two contacts in each receptacle shall be tested. The contacts shall be crimped to stranded steel cable of an appropriate size and installed in the connector. The unmated connector shall be mounted in a test fixture as shown on figure 13. A 13.6 newton-load (3 pounds) shall be applied to the cable. One 360° rotation of the fixture with the connector mounted shall constitute one cycle. The connector shall be subjected to 100 cycles at a rate of 10 to 20 cycles per minute.

4.7.30 Installing/removal tool abuse (qualification only) (see 3.33). One 8 gauge, one 12 gauge, one 16 gauge, and two 20 gauge contact cavities in each connector shall be subjected to each of the following test. Different contact cavities shall be used for each test. Should a tool become damaged during any of the testing, it shall be replaced. Failure of a tool shall not constitute a test failure. Tools shall be used in accordance with MIL-I-81969/14.

4.7.30.1 Removal tool rotation. The tool shall be inserted as if to remove a contact and a total of 13.6 newtons (3 pounds) axial load shall be applied. With the force applied, the tool shall be rotated 180° and then removed also removing the contact. The contact shall be reinserted. The steps shall be repeated three times on each of the contacts selected.

4.7.31 High temperature exposure

4.7.31.1 High temperature exposure with contact loading (see 3.34.1). Connectors with removable contacts shall have one mating pair of 16 gauge contacts removed from an untested contact cavity and replaced with contacts crimped or otherwise attached to steel cable or steel cored copper wire (copperweld, or equivalent) of an appropriate size. The axial location of these contacts shall be measured for conformance to the applicable dimensions of 3.1, with a load of approximately 8.9 newtons (2 pounds) applied to seat the contact back against the retention device. The connector shall then be mounted in a fixture equivalent to that shown on figure 6. A weight equal to 50 percent of the axial load specified in table XII for the applicable contact size shall be suspended freely from each steel wire. A current of 100 milliamperes maximum shall be applied to the test contacts and a suitable instrument shall be used to monitor the circuit for discontinuities in excess of 1 microsecond. The mounted connector shall then be exposed to 200°C for 1,000 hours minimum. After the connectors return to ambient temperature, they shall be unmated and the contact locations remeasured with approximately 8.9 newtons (2 pounds) axial load applied to seat the contact back against the retention device.

MIL-C-83538

4.7.31.2 High temperature exposure (see 3.34.2). Mated connectors, with an applied holding force of 289 newtons (65 pounds) $\pm 10\%$, shall be subjected to an ambient temperature of $200^{\circ}\text{C} +3^{\circ}\text{C}$, -0°C . The temperature shall be maintained for 1,000 hours. A suitable fixture, approved by the qualifying activity, shall apply a mating force of 289 newtons (65 pounds) $\pm 10\%$ to hold the connector pair together (see figure 14). A suitable fixture, approved by the qualifying activity, shall apply a mating force of 289 newtons (65 pounds) $\pm 10\%$ to hold the connector pair together (see figure 14).

4.7.31.3 Postlaunch temperature (see 3.34.3) Wired, unmated store receptacle shall be exposed to a temperature source. This temperature source shall apply heat at the rate of 1.6 watts per square centimeter until the connector reaches 480°C . Hold connector at this temperature for a period of 5 minutes. During this exposure, the insulation resistance test of 4.7.7.2 shall be conducted except the pass criteria shall be an insulation resistance of 10 megohms or greater. The store receptacle shall be inspected for structural integrity following this test by confirming compliance to the insert retention test of 4.7.9.

4.7.32 Electrolytic erosion (see 3.35). The launcher receptacle with buffer plug mated shall be mounted in a vertical position, pins facing up. A saltwater solution (5 percent salt by weight) shall be poured onto the pin interface until the solution level just reaches the pin tips. The solution shall remain in the connector for a minimum of 30 seconds and then poured out, lightly shaking excesses from the connector. The store receptacle shall immediately be mated to the buffer plug with a applied holding force of 289 newtons (65 pounds) $\pm 10\%$. One cell pattern, with all contacts adjacent to a central contact at a positive polarity and the center contact at a negative polarity, shall be set up at a location giving the most uniform distribution of contacts adjacent to the center contact. A potential of 60 volts dc shall be applied between the contacts adjacent to the center contact. The contacts shall be energized for 40 hours. Following this, with the voltage disconnected, the connectors shall be unmated and the pin contacts shall be examined using 3 X magnification for erosion to base metal.

4.7.33 Ice and freezing rain (see 3.36).

4.7.33.1 Severe ice test. The unmated wired connectors with accessories attached, shall be temperature stabilized at $+5^{\circ}\text{C}$ (41°F). The store receptacle connector shall be filled with a salt water solution (2.5% salt by weight) and then the water shall be emptied out by inverting the connector assembly. Immediately after, within 30 seconds, the connector shall be mated with its launcher counterpart. A suitable fixture, approved by the qualifying activity, shall apply a mating force of 289 newtons (65 pounds) $\pm 10\%$ to hold the connector pair together (see figure 14). The chamber temperature shall be reduced to -17.8°C (0°F) at a rate not less than $5^{\circ}\text{C}/\text{minute}$. The test specimen within the chamber shall be vibrated for the whole of the cooling cycle. After allowing the chamber temperature to stabilize at 17.8°C , the test specimen shall be soaked for 5 minutes minimum, during which vibration shall be continued. Upon completion of the soak period, the test specimen shall be removed from the chamber and immediately (within 30 seconds) subjected to unmating as provided in its user application. The force required to separate the connector shall not exceed 333 newtons (75 pounds).

4.7.33.2 Ice resistance test. Wired, mated connectors with an applied holding force of 289 $\pm 10\%$ newton, and with accessories attached shall be placed in a chamber and the temperature reduced and stabilized such that the item is maintained at -17.8°C for 1 hour. After stabilization of the chamber temperature, the test specimen shall be sprayed with water precooled to 1.7°C (35°F) for a period of 5 minutes. The test specimen shall be located at a maximum 305 mm (12 inches) from the spray nozzle. The entire test specimen shall remain in the chamber at -17.8°C for an additional 30 minutes. Upon completion of the 30 minute cold soak period, the test specimen shall be removed from the chamber and immediately (within 2 minutes) subjected to unmating as provided in its user application. The force required to separate the connector shall not exceed 333 newtons (75 pounds). A suitable fixture, approved by the qualifying activity, shall apply a mating force of 289 newtons (65 pounds) $\pm 10\%$ to hold the connector pair together (see figure 14).

4.7.34 Sand and dust (see 3.37). Wired, mated connectors shall be subjected to the blowing dust and blowing sand tests of MIL-STD-810, method 510. Blowing dust air velocity shall be 8.9 meters/second minimum. The blowing sand air velocity shall be 29 meters/second minimum with a sand concentration of 2.2 ± 0.5 grams/cubic meter. Immediately following this exposure, the decoupling force and coupling force shall be measured and shall not exceed the requirements specified in 3.8 by more than 25 percent. A suitable fixture, approved by the qualifying activity, shall apply a mating force of 289 newtons (65 pounds) $\pm 10\%$ to hold the connector pair together (see figure 14).

4.7.35 Magnetic permeability (see 3.3.5). Connectors shall be tested as specified in method 3006 of MIL-STD-1344.

MIL-C-83538

4.7.36 Post test examination The tested connectors and contacts shall be examined for compliance with 3.39 and 3.40 to determine the effects of previous testing. Any evidence of cracking, loosening of parts, carbon tracking, excess wear, or missing parts shall be recorded.

4.7.37 Insert bonding integrity (see 3.37) Unmated unwired connector receptacles shall be subjected to test procedure 78 of EIA-364.

5 PACKAGING

5.1 Packaging requirements The requirements for packaging shall be in accordance with MIL-C-55330.

5.1.1 Dust caps Dust caps in accordance with MS90376 (or equivalent cap) shall be placed on the mating end of each connector.

6 NOTES

(This section contains information of a general or explanatory nature that may be helpful, but is not mandatory.)

6.1 Intended use This connector is designated the MIL-STD-1760, type II connector. This connector assembly will be used to provide the transfer of MIL-STD-1760 interface class I electrical signals and power between an aircraft (or ground vehicle) mounted launcher and an associated store. This connector is intended to be used on rail and eject launchers where engagement/disengagement of the launcher receptacle (with attached buffer plug) to the store receptacle will be via a blindmate mechanical mechanism. The signal and power transfer may occur at various phases of all store operations from store upload through store launch. In addition, the connectors may be used with suitable test equipment for various tests of the store and aircraft in the factory-to-upload sequence.

6.2 Acquisition requirements Acquisition documents must specify the following:

- a. Title, number, and date of this specification.
- b. Issue of DODISS to be cited in the solicitation, and if required, the specific issue of individual document referenced (see 2.1).
- c. PIN (see 3.42).
- d. Whether contacts, sealing plugs, and tools are included (see 1.3.1, 3.4.2, and 3.4.4.2).

6.3 Qualification With respect to products requiring qualification, awards will be made only for products which are at the time of award of contract, qualified for inclusion in the Qualified Products List QPL No. 83538 whether or not such products have actually been so listed by that date. The attention of the contractors is called to these requirements, and manufacturers are urged to arrange to have products that they propose to offer to the Federal Government tested for qualification in order that they may be eligible to be awarded contracts or purchase orders for the products covered by this specification. The activity responsible for the qualified products list is the 645 Logistic Operation, Group, Electronic Support Flight (LOG/LGME), Gentile AFS, 1060 Hamilton St, Dayton, Ohio 45444-5400.

6.3.1 Qualifying activities Unless otherwise notified, information pertaining to the qualification of products may be obtained from the following agencies:

- a. Initial qualification and requalification

Naval Air Warfare Center, Aircraft Division
Code DP704n, M/S 60
6000 East 21st Street
Indianapolis, IN 46219-2189

MIL-C-83538

- b Plant audit, retention of qualification, and design changes

Defense Electronics Supply Center
DESC-ELS
Dayton, OH 45444-5270

6.3.2 Copies of "Provisions Governing Qualification SD-6" Copies of "Provisions Governing Qualification SD6" may be obtained upon application to Commanding Officer, Naval Publications and Forms Center, 5801 Tabor Avenue, Philadelphia, PA 19120

6.4 Definitions

6.4.1 Blindmate A situation in which personnel wishing to mate a connector can neither see nor touch the connector halves being mated and must rely on some mechanism to accomplish the mating

6.4.2 Scoopproof Scoopproof means that because of the connector long shell design, it is impossible for the mating plug connector to inadvertently be cocked into the mating receptacle and damage the pins or electrically short the contacts.

6.5 Applicable contacts.

MIL-C-39029			
	Power	Coaxial	Twinaxial
Socket	/56	/75, /103	/91

6.6 Patent notice The Government has a royalty-free license under any applicable patents and applications for patents, for the benefit of manufacturers of this connector whether for the Government or for use in equipment to be delivered to the Government.

6.7 International standardization agreement. Certain provisions of this specification are subject of international standardization agreement, NEPR 99. When amendment, revision, or cancellation of this specification is proposed which will affect or violate the international agreement concerned, the preparing activity will take appropriate action through international standardization channels including departmental standardization offices, to change the agreement or make other appropriate accommodations

6.8 Subject term (key word) listing

Blind mating
Buffer plug
Environmental
Launch receptacle
Quick disconnect
Store receptacle

MIL-C-83538

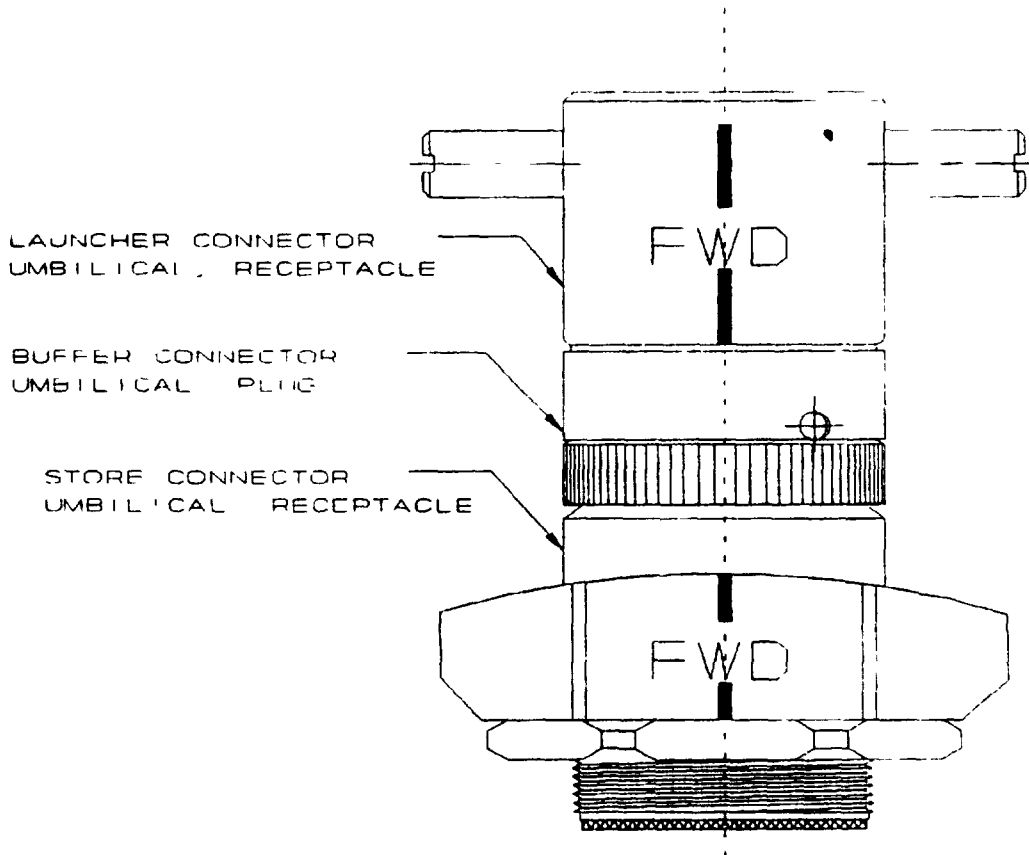
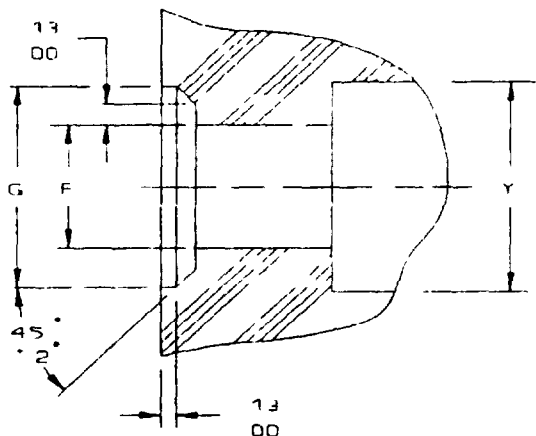
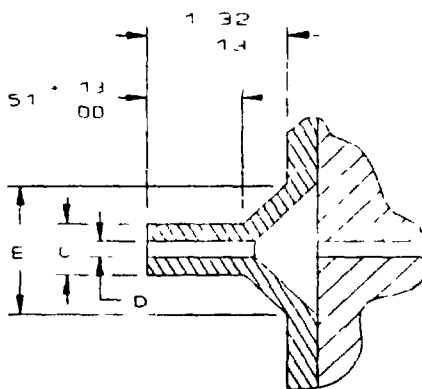

FIGURE 1 Electrical umbilical assembly

MIL-C-83538



DETAIL A SOCKET ENTRY



DETAIL B PIN BARRIER

mm	Inches
0.00	.000
0.13	.005
0.51	.020
1.32	.052

Contact size	Detail A		Detail B		
	F dia	G dia	E dia	C dia	D dia max
20	1.32 (.052)	2.26 (.089)	2.44 (.096)	1.91 (.075)	0.97 (.038)
	1.24 (.049)	2.16 (.085)	2.31 (.091)	1.83 (.072)	
16	1.88 (.074)	2.84 (.111)	3.02 (.119)	2.49 (.098)	1.52 (.060)
	1.80 (.071)	2.74 (.108)	2.90 (.114)	2.41 (.095)	
12	2.69 (.106)	3.66 (.144)	3.84 (.151)	3.30 (.130)	2.34 (.092)
	2.62 (.103)	3.56 (.140)	3.71 (.146)	3.23 (.127)	
8	5.84 (.230)	6.81 (.268)	7.06 (.278)	6.50 (.256)	5.49 (.216)
	5.77 (.227)	6.71 (.264)	6.93 (.273)	6.38 (.251)	

NOTES

- 1 Dimensions are in millimeters
- 2 Inch-pound equivalents are in parentheses and are for information only

FIGURE 2 Interface design

MIL-C-83538

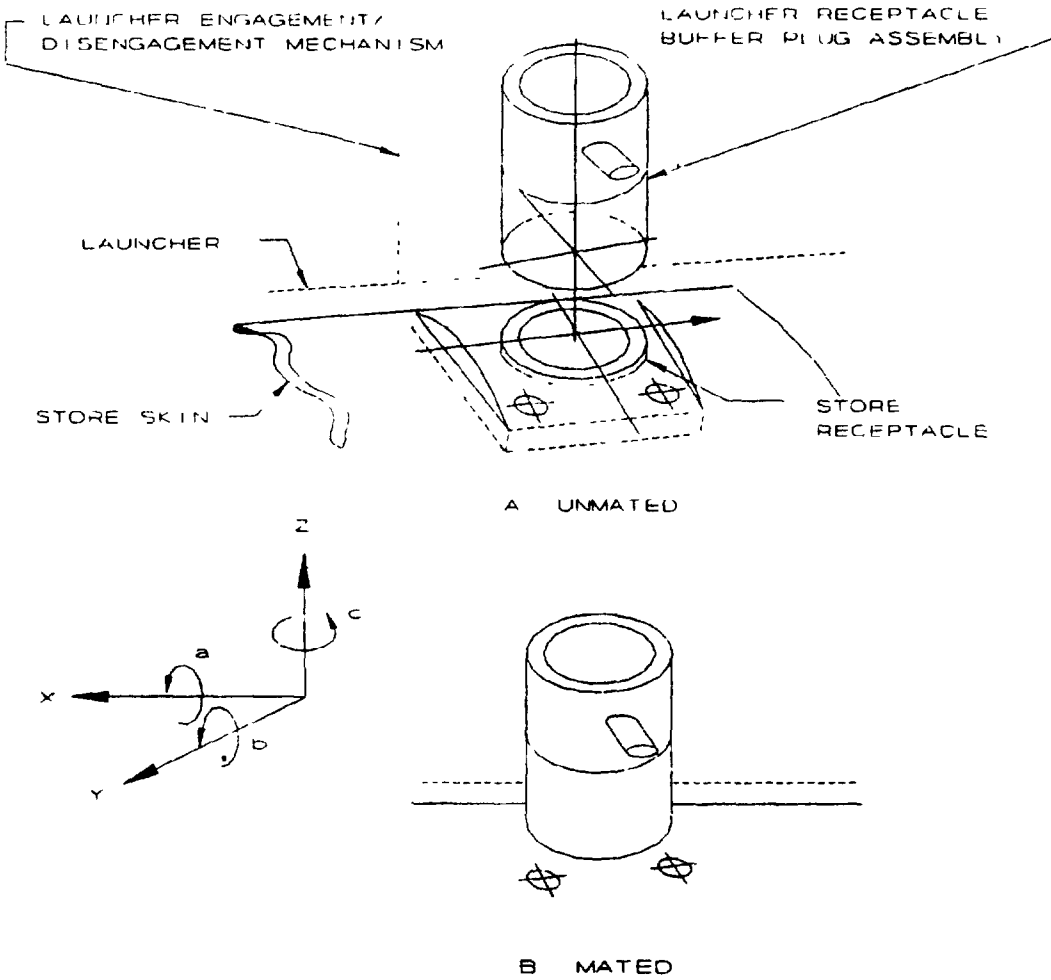
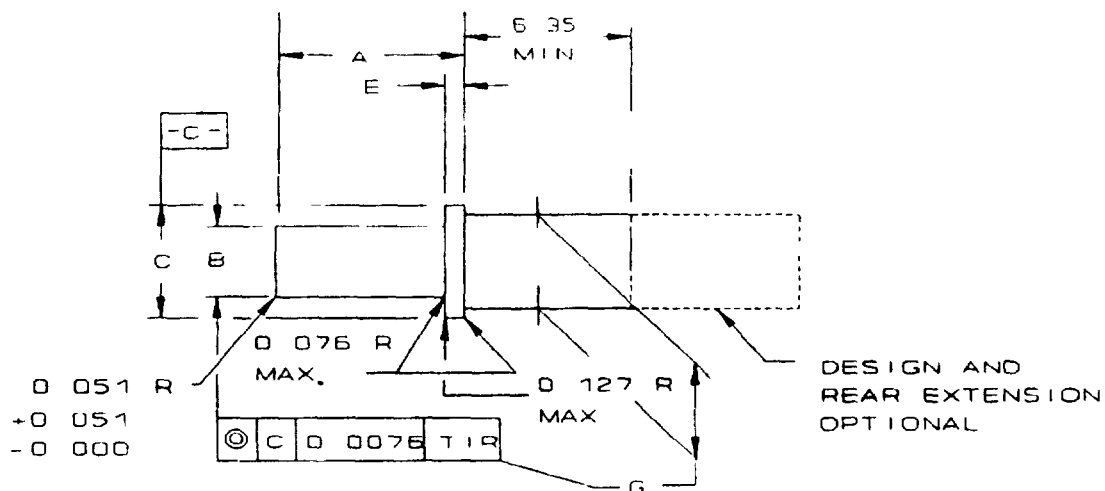

FIGURE 3 Axis and angle definitions

MIL-C-83538



Contact size	A	B dia	C dia	E	G dia
	+0.0127 (.00050) -0.0000 (.00000)	+0.0051 (.00020) -0.0000 (.00000)	+0.0051 (.00020) -0.0000 (.00000)	+0.0000 (.00000) -0.0051 (.00020)	+0.0000 (.00000) -0.0051 (.00020)
20	14.86 (.585)	1.955 (.0770)	2.311 (.0910)	0.838 (.0330)	1.788 (.0704)
16	14.86 (.585)	2.845 (.1120)	3.226 (.1270)	0.838 (.0330)	2.616 (.1030)
12	14.86 (.585)	4.064 (.1600)	4.547 (.1790)	0.838 (.0330)	3.835 (.1510)
8	14.986 (.590)	7.290 (.2870)	7.899 (.3110)	0.838 (.0330)	7.010 (.2760)

NOTES.

1. Dimensions are in millimeters
2. Inch-pound equivalents are given for general information only
3. Material: Hardened tool steel
4. Finish: 32 microinches polished
5. Use store receptacle and launcher receptacle MIL-C-83538/1 and MIL-C-83538/4

FIGURE 4 Test gauge, socket, and location

MIL-C-83538

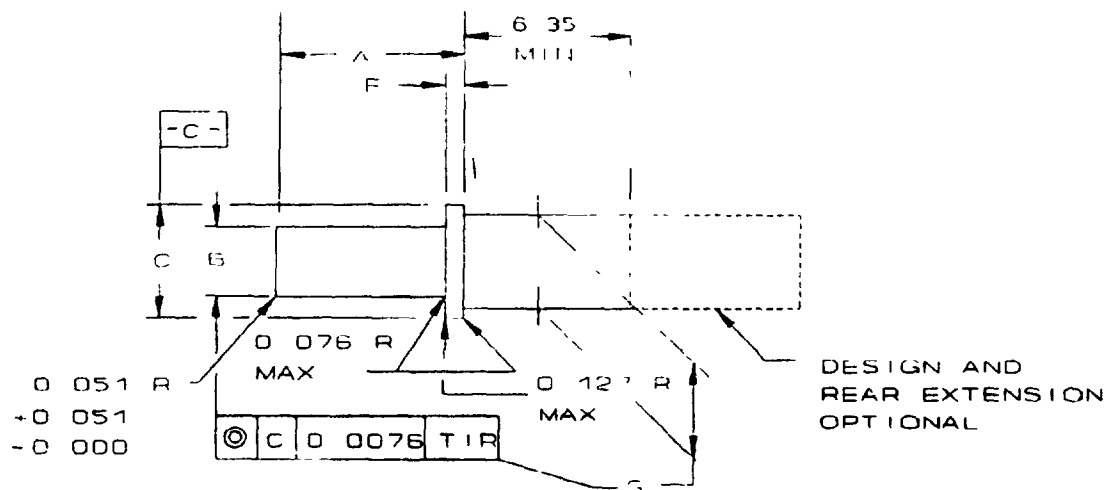

mm	Inches	mm	Inches
0.000	.0000	0.076	.0030
0.0076	.00030	0.127	.0050
0.025	.0010	0.250	.0098
0.051	.0020	6.35	.250

Contact size	A	B dia	C dia	E	G dia
	+0.0127 (.00050) -0.0000 (.00000)	+0.0051 (.00020) -0.0000 (.00000)	+0.0051 (.00020) -0.0000 (.00000)	+0.0000 (.00000) -0.0051 (.00020)	+0.0000 (.00000) -0.0051 (.00020)
20	15.90 (.626)	1.956 (.0770)	2.311 (.0910)	0.8382 (.03300)	1.778 (.0700)
16	15.90 (.626)	2.845 (.1120)	3.226 (.1270)	0.8382 (.03300)	2.616 (.1030)
12	15.90 (.626)	4.064 (.1600)	4.547 (.1790)	0.8382 (.03300)	3.835 (.1510)
8	16.027 (.630)	7.290 (.2870)	7.899 (.3110)	0.8382 (.03300)	7.010 (.2760)

NOTES

- 1 Dimensions are in millimeters
- 2 Inch-pound equivalents are given for general information only
3. Material: Hardened tool steel
- 4 Finish: 32 microinches polished
- 5 Use with store receptacle and launcher receptacle MIL-C-83538/1 and MIL-C-83538/4

FIGURE 5 Test gauge, socket, and retention

MIL-C-83538

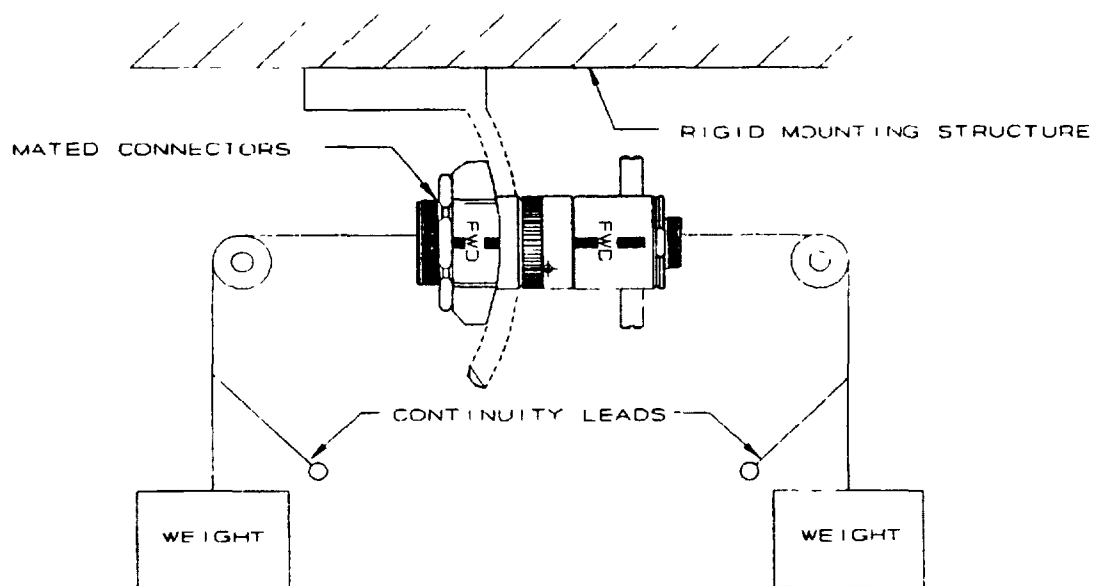

FIGURE 6 Typical fixturing for temperature life with contact loading (orientation optional)

MIL-C-83538

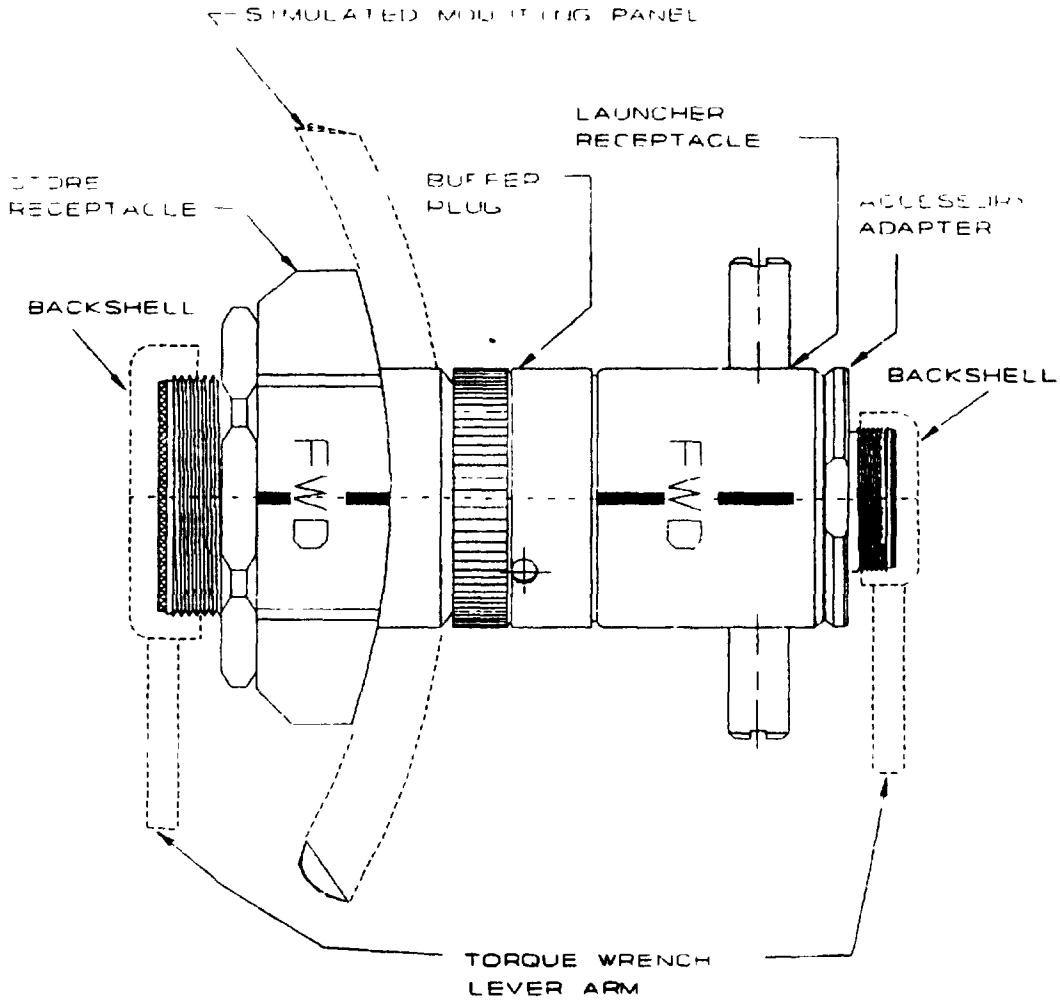
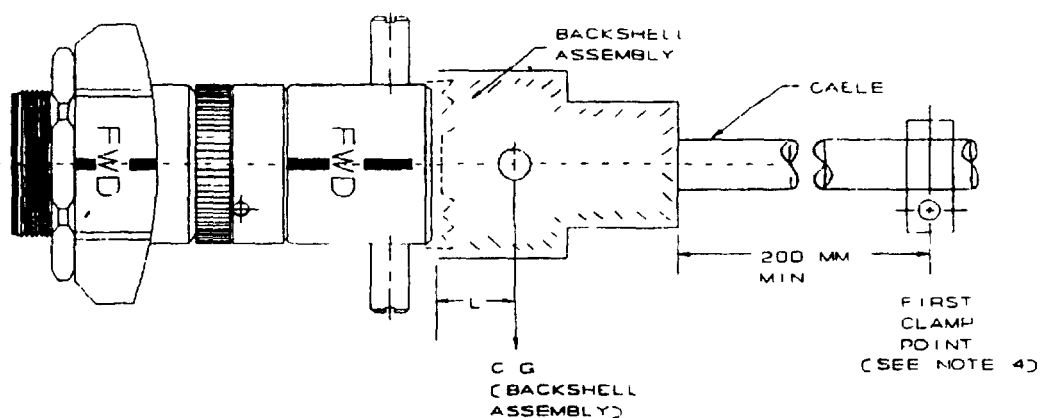

FIGURE 7 Rear accessory thread strength test setup

MIL-C-83538



Shell size	L (mm) root to C.G. +10% - 0%	Wt. (kg) backshell assembly +10% - 0%
25	23.37 (920)	.31

NOTES-

1. Dimensions are in millimeters
2. Inch-pound equivalents are for information only and are in parentheses
3. Shape of test accessory is optional
4. The test accessory may include a strain relief clamp
5. Clamp point to be located on vibration table, and cable weight between rear of grommet and tie down clamp point to be considered a portion of the backshell assembly weight

FIGURE 8 Vibration test accessory

MIL-C-83538

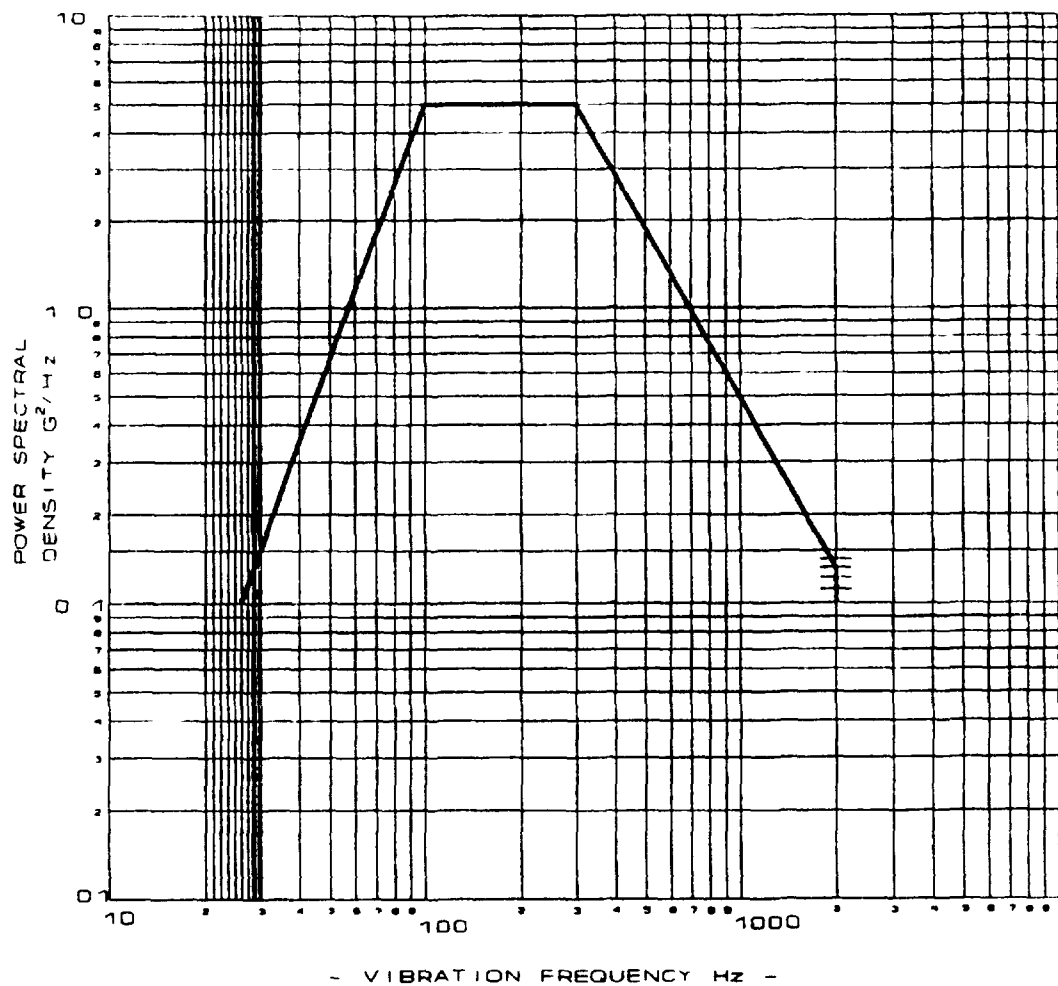
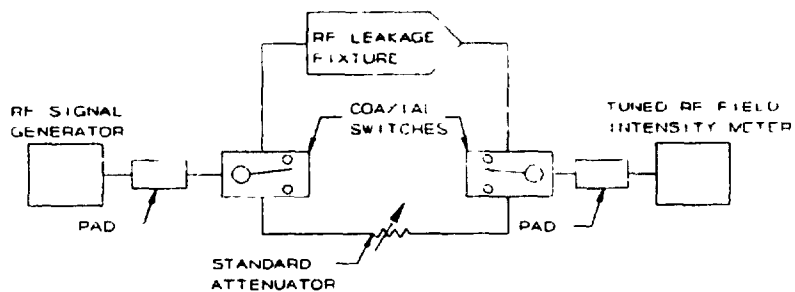

FIGURE 9 Random vibration

MIL-C-83538



SCHEMATIC TEST SYSTEM

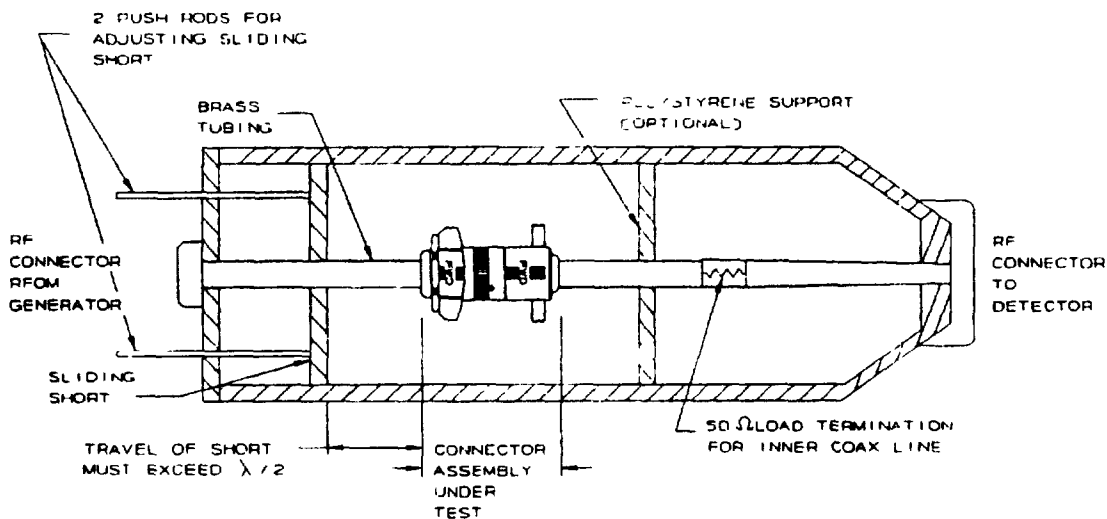
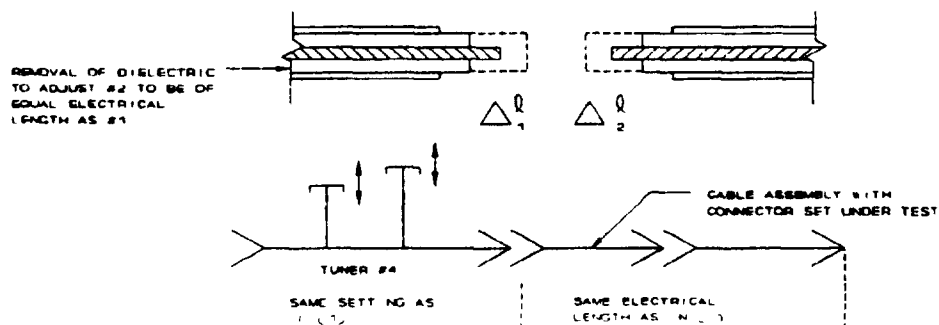
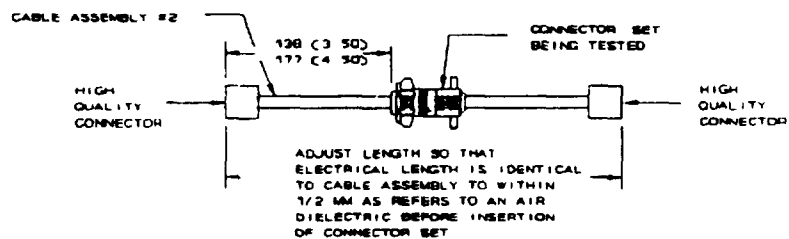
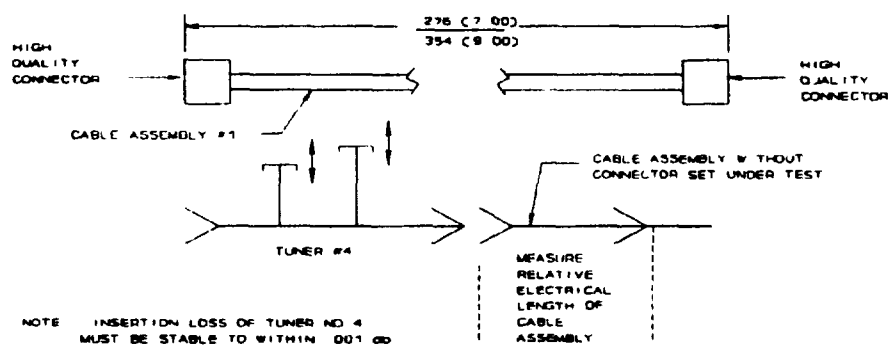
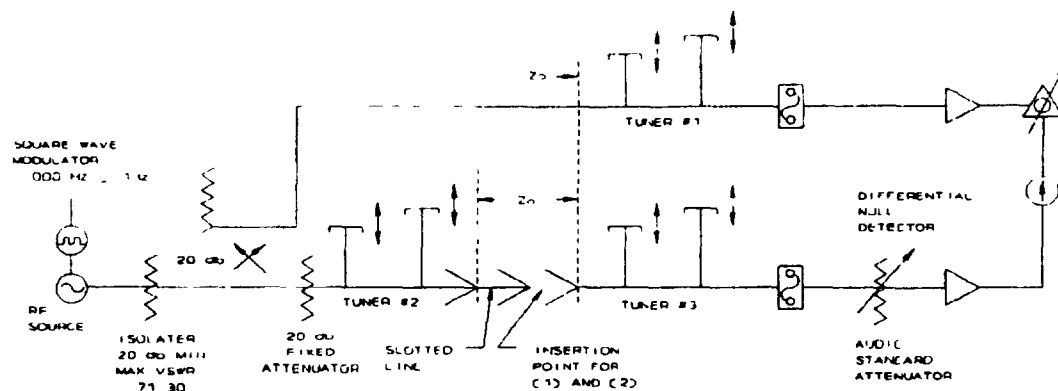

FIGURE 10 RFI leakage test fixture

MIL-C-83538



NOTES

1. Dimensions are in millimeters.
2. Inch-pound equivalents are for information only and are in parentheses.

FIGURE 11 Method of insertion loss measurement of mated connector

MIL-C-83538

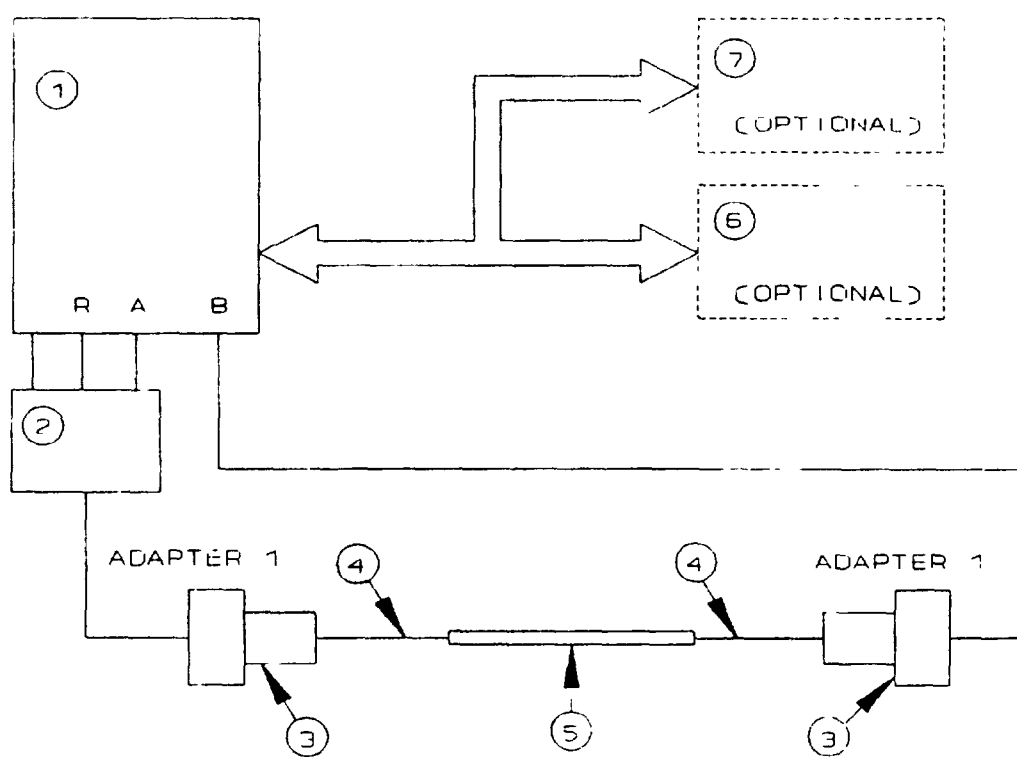

Equipment list

- 1 Vector network analyzer (HP8753A (OPT 010) or equivalent)
- 2 Transmission/reflection test set (HP85044A or equivalent)
- 3 Adapters
- 4 M17/113-RG316 cable
- 5 Mated contact pair (contact under test)
- 6 X-Y plotter
- 7 Test controller (computer)

FIGURE 12 VSWR test setup

MIL-C-85538

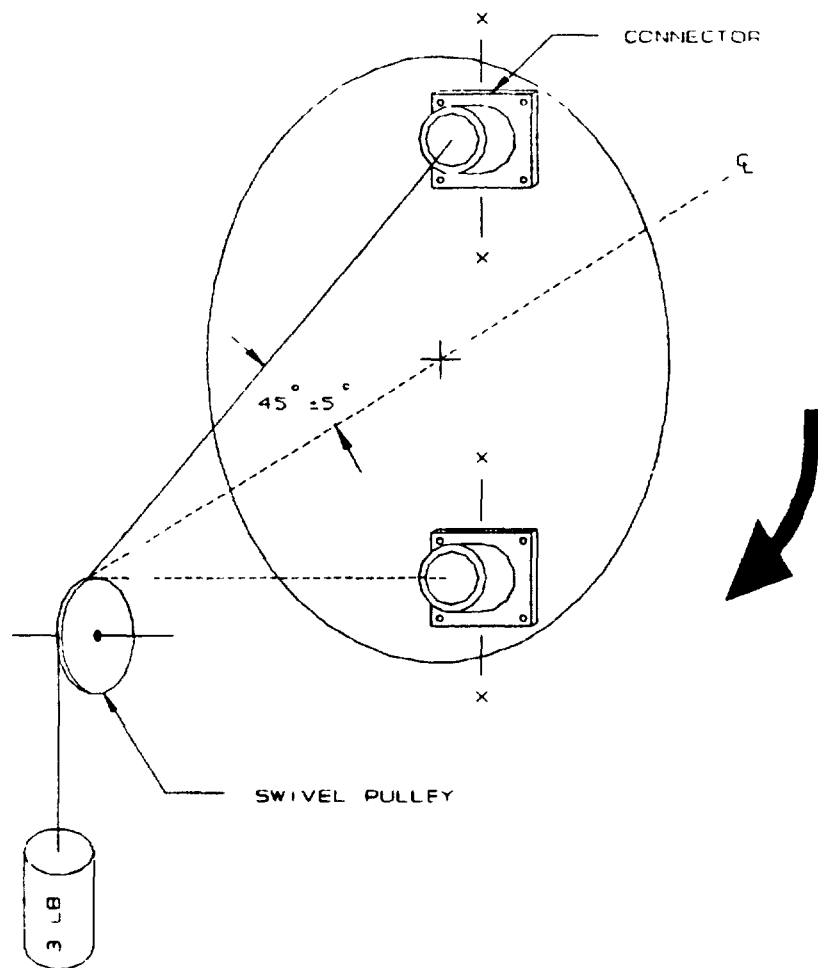

FIGURE 13 Contact walk-out test setup

MIL-C-83538

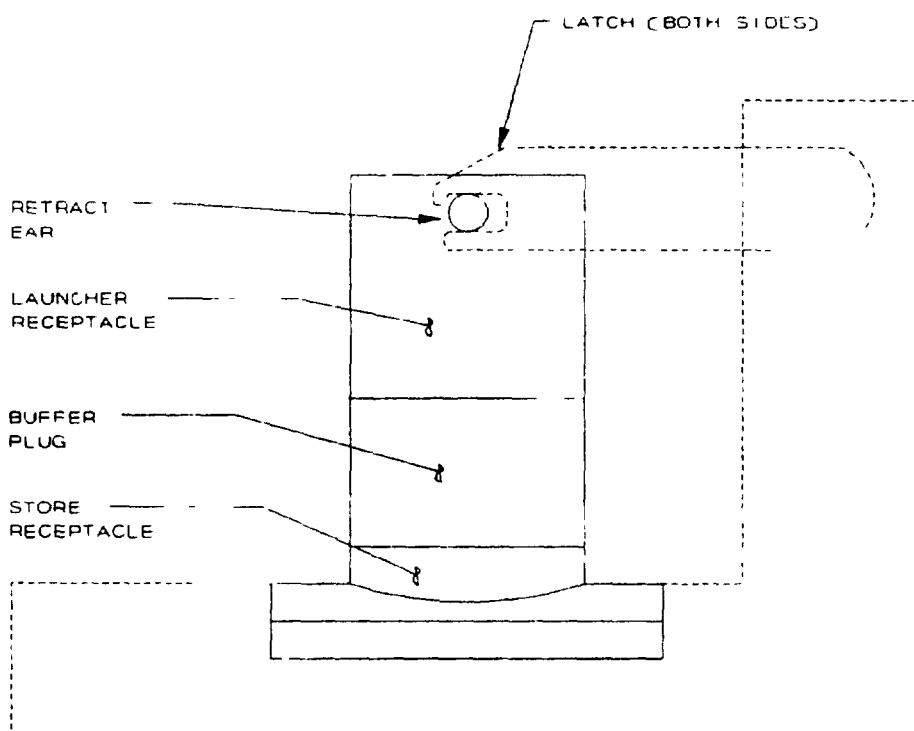

FIGURE 14 Typical fixturing for tests requiring mated connectors

MIL-C-83538

CONCLUDING MATERIAL

Custodians

Army - CR
Navy - AS
Air Force - 85

Review activities

Army - AR, MI
Navy - EC, MC, OS
Air Force - 11, 15, 17, 99

Preparing activity
Air Force - 85

Agent.
DLA - ES

(Project 5935-3900)

STANDARDIZATION DOCUMENT IMPROVEMENT PROPOSAL

INSTRUCTIONS

- 1 The preparing activity must complete blocks 1, 2, 3, and 8. In block 1, both the document number and revision letter should be given.
- 2 The submitter of this form must complete blocks 4, 5, 6, and 7.
- 3 The preparing activity must provide a reply within 30 days from receipt of the form.

NOTE This form may not be used to request copies of documents, nor to request waivers, or clarification of requirements on current contracts. Comments submitted on this form do not constitute or imply authorization to waive any portion of the referenced document(s) or to amend contractual requirements.

I RECOMMEND A CHANGE:	1. DOCUMENT NUMBER MIL-C-83538	2. DOCUMENT DATE (YYMMDD)
3. DOCUMENT TITLE CONNECTORS AND ACCESORIES, ELECTRICAL, CIRCULAR, UNBILICAL, ENVIRONMENT RESISTANT REMOVABLE CRIMP CONTACTS, FOR MIL-STD-1760 APPLICATIONS (METRIC), GENERAL SPECIFICATION FOR		
4. NATURE OF CHANGE (Identify paragraph number and include proposed rewrite, if possible. Attach extra sheets as needed.)		
5. REASON FOR RECOMMENDATION		
6. SUBMITTER		
7. ORGANIZATION		
8. ADDRESS (Include Zip Code)	9. TELEPHONE (Include Area Code) (1) Commercial (2) AUTOVON (if applicable)	7. DATE SUBMITTED (YYMMDD)
8. PREPARING ACTIVITY		
a. NAME 645 LOG/LGME	b. TELEPHONE (Include Area Code) (1) Commercial (2) AUTOVON	
c. ADDRESS (Include Zip Code) Gentile AFS 1060 Hamilton Street Dayton OH 45444-5400	IF YOU DO NOT RECEIVE A REPLY WITHIN 45 DAYS, CONTACT: Defense Quality and Standardization Office 5203 Leesburg Pike, Suite 1403, Falls Church, VA 22041-3466 Telephone (703) 756-2340 AUTOVON 289-2340	