

MILITARY SPECIFICATION

CONNECTORS, PLUG AND RECEPTACLE,
ELECTRICAL, RECTANGULAR MULTIPLE INSERT TYPE,
RACK TO PANEL, ENVIRONMENT RESISTING,
150°C TOTAL CONTINUOUS OPERATING TEMPERATURE,
GENERAL SPECIFICATION FOR

This specification is approved for use by all Departments and Agencies of the Department of Defense.

1. SCOPE

1.1 Scope. This specification covers the requirements, quality assurance criteria and test procedures for the design and fabrication of an environment resisting low insertion force, multiple insert rectangular connector. The low insertion force rectangular connector is intended for use in the electrical/electronic bay areas of military aircraft. The connector shall provide the electrical interface between the avionics equipment and the equipment rack or tray.

1.2 Classification.

1.2.1 Class and series. The connector class shall be identified as follows:

Class R - Environment resisting connector for continuous operation within the temperature limits of -65°C to +150°C.

1.3 Military part number- An example of the military part number is shown below:

	D83527	/03-001	
Basic specification identifier			
Specification sheet number			
Insert arrangement designator			
from DOD-STD-1842			

2. APPLICABLE DOCUMENTS

2.1 Government documents.

2.1.1 Specifications, standards, and handbooks. Unless otherwise specified, the following specifications, standards, and handbooks of the issue listed in the Department of Defense Index of Specifications (DoDISS) specified in the solicitation form a part of this specification to the extent specified herein.

SPECIFICATIONS

FEDERAL

QQ-A-250	-	Aluminum and Aluminum Alloy Plate and Sheet, General Specification for.
QQ-A-367	-	Aluminum Alloy Forgings.
QQ-P-416	-	Plating, Cadmium (Electrodeposited).
QQ-A-591	-	Aluminum Alloy Die Casting.

Beneficial comments (recommendations, additions, deletions) and any pertinent data which may be of use in improving this document should be addressed to Air Force 2750th Air Base Wing, Electronic Support Division (2750 ABW/ES) Gentile Air Force Station, Dayton, Ohio 45444, by using the self-addressed Standardization Document Improvement Proposal (DD Form 1426) appearing at the end of this document, or by letter

DOD-C-83527

MILITARY

MIL-M-14	-	Molding Plastics and Molded Plastic Parts, Thermosetting.
MIL-C-17	-	Cables, Radio Frequency, Flexible and Semi-Rigid, General Specification for.
MIL-C-22520	-	Crimping Tools, Terminal, Hand or Power Actuated Wire Termination, and Tool Kits.
MIL-W-22759	-	Wire, Electric, Fluoropolymer-insulated, Copper or Copper Alloy.
MIL-M-24519	-	Molding Plastics, Electrical, Thermoplastic.
MIL-C-39029	-	Contacts, Electrical Connector, General Specification for.
MIL-C-55330	-	Connectors, Electrical and Fiber Optic, Packaging of.
MIL-C-85049	-	Connector Accessories, Electrical, General Specification for.
MIL-I-81969	-	Installing and Removal Tools, Connector, Electrical Contact, General Specification for.

STANDARDS

MILITARY

DOD-STD-1788	-	Avionics Interface Design.
DOD-STD-1842	-	Insert Arrangements for DOD-C-83527 Rack-to-Panel Connectors.
MIL-STD-105	-	Sampling Procedures and Tables for Inspection by Attributes.
MIL-STD-202	-	Test Methods for Electronic and Electrical Component Parts.
MIL-STD-454	-	Standard General Requirements for Electronic Equipment.
MIL-STD-790	-	Reliability Assurance Program for Electronic Parts Specifications.
MIL-STD-1285	-	Marking of Electrical and Electronic Parts.
MIL-STD-1344	-	Test Methods for Electrical Connectors.
MIL-STD-27488	-	Plug, End Seal, Electrical Connector.
MIL-STD-45662	-	Calibration Systems Requirements.

2.1.2 Order of precedence. In the event of a conflict between the text of this specification and the references cited herein, the text of this specification shall take precedence.

3. REQUIREMENTS

3.1 Specification sheets. The individual item requirements shall be as specified herein and in accordance with the applicable specification sheets. In the event of any conflict between requirements of this specification and the specification sheet, the latter shall govern.

3.2 Qualification. Connectors furnished under this specification shall be products which are qualified for listing on the applicable qualified products list at the time set for opening of bids (see 4.4 and 6.3).

3.2.1 Reliability. The contractors reliability program for assembled connectors and assembly procedures shall meet the requirements of MIL-STD-790.

3.3 Materials. Materials shall be as specified herein. When a definite material is not specified, material shall be used which will enable the connectors to meet the performance requirements of the applicable specification. Acceptance or approval of any constituent material shall not be construed as a guaranty of the acceptance of the finished product.

3.3.1 Metals. Metals shall be of a corrosion-resistant type or shall be plated or treated to resist corrosion.

3.3.1.1 Dissimilar metals and compatible couples. When dissimilar metals are used in intimate contact with each other, protection against electrolysis and corrosion shall be provided. The use of dissimilar metals in contact, which tend toward active electrolytic corrosion (particularly brass, copper, or steel used in contact with aluminum alloy) is not acceptable. However, metal plating or metal spraying of dissimilar-base metals to provide similar or suitable abutting surfaces is permitted. The use of dissimilar metals separated by a suitable insulating material is also permitted. Dissimilar metals and compatible couples are defined in requirement 16 of MIL-STD-454.

DOD-C-83527

3.3.1.2 Hydrolytic stability. All nonmetallic material shall be selected to meet the hydrolytic reversion resistance requirements specified in requirement 47 of MIL-STD-454 (see 4.1.4).

3.3.2 Nonmagnetic materials. The relative permeability of the wired, assembled, and fully mated connector assembly shall be less than 2.0 when measured in accordance with 4.7.29.

3.3.3 Fungus resistant. Materials used in the construction of these connectors shall be fungus inert in accordance with requirement 4 of MIL-STD-454 (see 4.1.5).

3.3.4 Shell material. Unless otherwise specified, the shell material shall be a high grade aluminum alloy in accordance with QQ-A-250 or forging alloy conforming to QQ-A-367 or die cast alloy per QQ-A-591, composition number 13, A13, 380, A380 or SC114A.

3.3.5 Rigid insert material. Rigid insert material shall be selected from glass fiber filled diallyl phthalate per MIL-M-14, type SDG-F or nonflammable thermoplastic per MIL-M-24519. Alternate materials may be used provided they exhibit stability when exposed to long term high temperature and high humidity conditions and meet the performance requirements specified herein.

3.3.6 Resilient insert material. Resilient material shall be a high grade fluorosilicone elastomer and shall be capable of meeting the performance requirements of this specification.

3.3.7 Finish. All metal parts shall be made of corrosion-resistant materials or be protected to meet the performance requirements of this specification. The shell and backshell hardware shall have cadmium plate in accordance with QQ-P-416 over a suitable underplate to withstand 500-hour salt spray test. Final finish shall be electrically conductive and shall be silver to light indescent yellow in color.

3.4 Design and construction. Connectors shall be in accordance with the applicable specification sheet and shall be constructed to withstand normal handling incident to installation and maintenance in service. Configuration and dimensions to ensure intermateability shall be in accordance with figures 1 and 2 and the detail specification sheets. Connectors shall permit individual insertion and removal of contacts without removing the insert or sealing members.

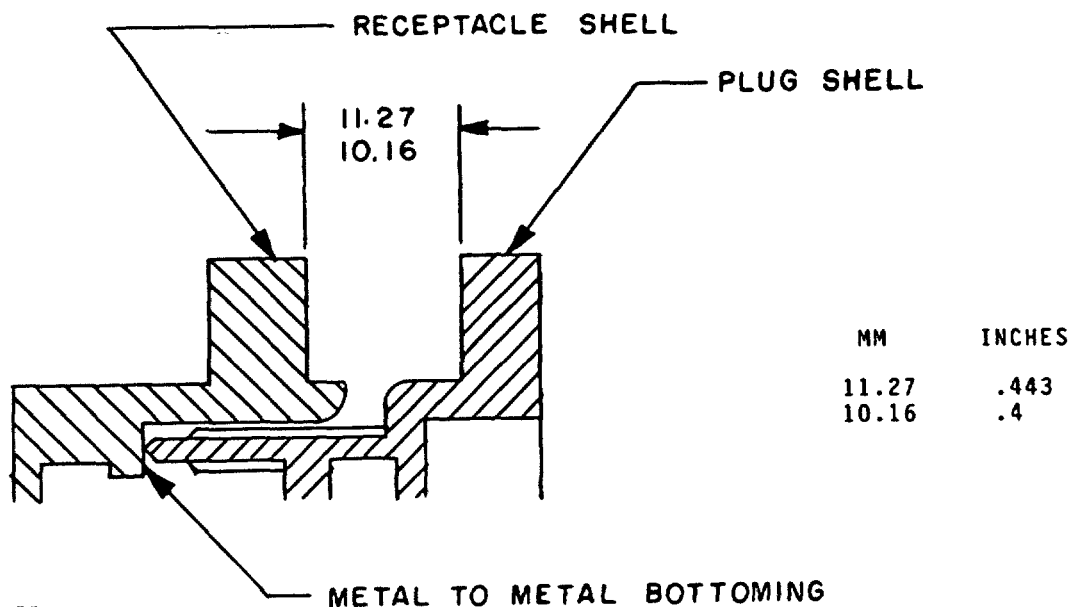

NOTES:

1. Dimensions are in millimeters.
2. Inch equivalents are given for general information only.

FIGURE 1. Shell mating condition.

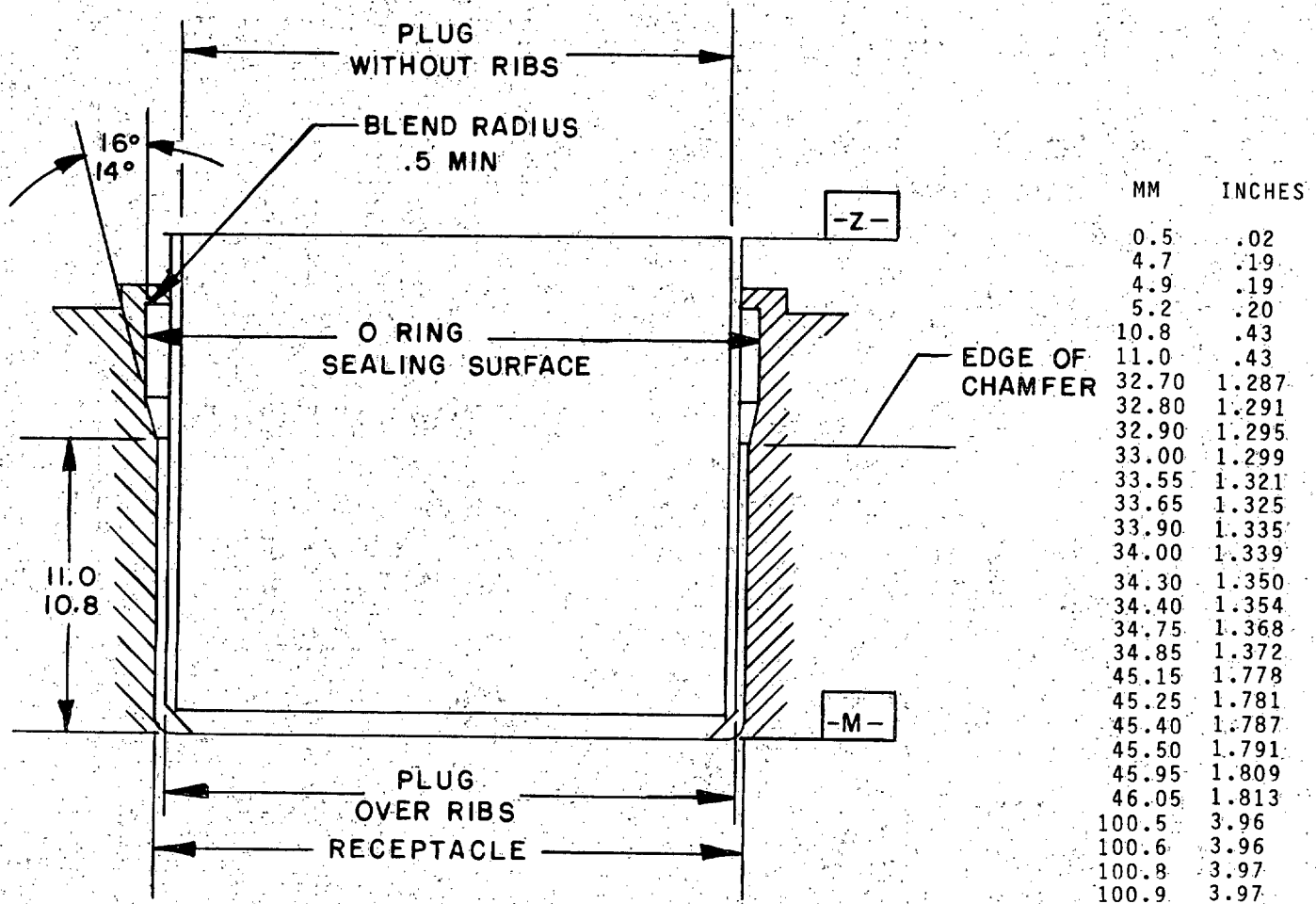

DIMENSIONS AND TOLERANCES. MILLIMETERS						
(SEE NOTE 1)						
CONNECTOR TYPE	LOCATION	HEIGHT			CORNER RADII	OVERALL HEIGHT
		CAVITY A or C	CAVITY B or D	WIDTH		
Plug	At Plane Z	45.25	34.00	32.80	5.2	100.6
		MAX.	MAX.	MAX.	4.9	MAX.
	Over Ribs	45.25	34.00	32.80	5.2	100.6
		45.15	33.90	32.70	4.9	100.5
Receptacle	Edge of Chamfer to Datum -M-	45.50	34.40	33.00	4.9	100.9
		45.40	34.30	32.90	4.7	100.8
	O-Ring Surface	46.05	34.85	33.65	4.9	--
		45.95	34.75	33.55	4.7	--

NOTES:

1. Dimensions and tolerances are based on symmetry about the true positions of grid datums X₂, X₃, Y₂, and Y₃ as applicable, see Figure 1.
2. Dimensions of insert cavities shall be determined from standard insert dimensions and contact true position tolerances, see Figure 3.
3. External configuration of connector shall be determined by the applicable specification sheet.
4. Dimensions are in millimeters.
5. Inch equivalents are given for general information only.

FIGURE 2. Connector shell intermateability dimensions.

DOD-C-83527

3.4.1 Contacts. Unless otherwise specified (see 3.1), contacts shall be designed for crimp termination, rear release, and rear removal. Contacts shall be as specified in table I and shall be qualified to MIL-C-39029 (see 6.2).

3.4.2 Tools. Installing and removal tools shall be as specified in table I and shall be qualified to MIL-I-81969. Crimping tools shall be as specified in table I and shall be qualified to MIL-C-22520 (see 6.2). One installing and/or removal tool for each size contact shall be enclosed in the unit package.

3.4.3 Insert. The insert assembly shall be a mono-bloc type design complete with inserts, contact retention members, and appropriate seals bonded into an integral unit. All parts shall be designed and constructed with proper sections and radii so that they will not chip, crack or break in assembly or other normal service. The insert assembly shall be designed and constructed so as to eliminate all air paths between contact cavities and between contact cavities and shell. Peripheral seal "O" Ring shall be lubricated with Parker "Super-O-Lube" or equivalent. The insert assemblies shall meet the interface dimensional requirements specified in figures 3 and 4.

3.4.3.1 Plug insert. Plug insert assemblies shall have rigid dielectric front face. Contact cavities shall be designed for recessed contacts (size 22 pin contacts and socket contacts for all other sizes).

3.4.3.2 Receptacle insert. Receptacle insert assemblies shall have resilient interfacial seal. Contact cavities shall be designed for exposed contacts (size 22 socket contacts and pin contacts for all other sizes).

TABLE I. Contacts and tools.

Contact Size & type	Pin	Socket	Installing tool	Removal tool	Crimp tool	Positioner
22-22	M39029/93	M39029/94	M81969/1-01	M81969/1-01	M22520/2-01	M22520/2-23
20-20	M39029/93	M39029/94	M81969/1-02	M81969/1-02	M22520/2-01 M22520/7-01	M22520/2-08 M22520/7-02
16-16	M39029/93	M39029/94	M81969/1-03	M81969/1-03	M22520/1-01 M22520/7-01	M22520/1-02 Blue M22520/7-03
12-12	M39029/93	M39029/94	---	M81969/28-02	M22520/1-01	M22520/1-11
1 Coax	M39029/97	M39029/98	---	M81969/XX	Inner M22520/XX Outer M22520/XX	Inner M22520/XX Outer M22520/XX
5 Coax	M39029/99	M39029/100	---	M81969/28-01	Inner M22520/2-01 Outer M22520/5-01	Inner M22520/XX Outer M22520/5-45A
8 Concen- tric twinax	M39029/96	M39029/95	M81969/14-06	M81969/14-06	Inner M22520/2-01 Intermediate & Outer M22520/5-01	Inner M22520/2-37 Intermediate & Outer M22520/5-200

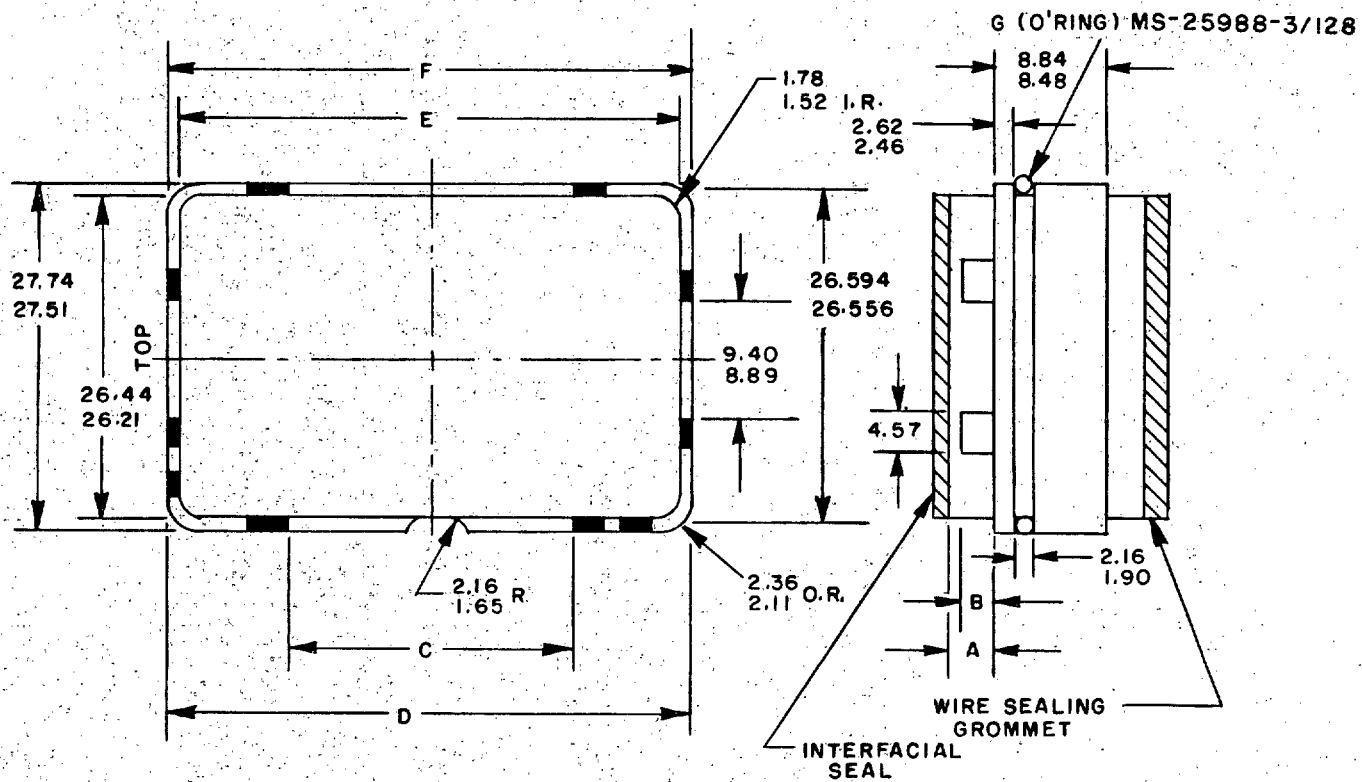

FIGURE 3. Insert interface dimensions for high density insert with size 22 contact cavities arrangements.

DOD-C-83527

SHELL STYLE	INSERT CAVITITES	A	B	C	D	E	F	G
PLUG	A.C.E	13.18	12.19	22.10	39.040	38.89	40.18	1.50 W
		12.98	11.55					X
RECEP	A.C.E	3.61	2.67	21.59	39.002	38.66	39.95	35.23 I.D.
		3.40	2.03					
PLUG	B.D.F	13.18	12.19	9.40	27.864	27.71	29.01	1.50 W
		12.98	11.56					X
RECEP	B.D.F	3.61	2.67	8.89	27.826	27.48	28.78	27.91 I.D.
		3.40	2.03					

MM	INCHES	MM	INCHES
1.50	.059	22.10	.870
1.52	.060	26.21	1.032
1.65	.065	26.44	1.041
1.78	.070	26.556	1.0455
1.90	.075	26.594	1.0470
2.03	.080	27.48	1.082
2.11	.083	27.51	1.083
2.16	.085	27.71	1.091
2.36	.093	27.74	1.092
2.46	.097	27.81	1.095
2.62	.103	27.864	1.0970
2.67	.105	28.78	1.133
3.40	.134	29.01	1.142
3.61	.142	38.66	1.522
4.57	.180	38.89	1.531
8.48	.339	39.002	1.5355
8.89	.35	39.040	1.5370
9.40	.370	39.95	1.5728
11.56	.455	40.18	1.5819
12.19	.480		
12.98	.511		
13.18	.519		

NOTE:

1. Interfacial seal applies to exposed contact inserts only (size 22 socket inserts or other size pin inserts).
2. Dimensions are in millimeters.
3. Inch equivalents are given for general information only.

FIGURE 3. Insert interface dimensions for high density insert with size 22 contact cavities arrangements. - Continued.

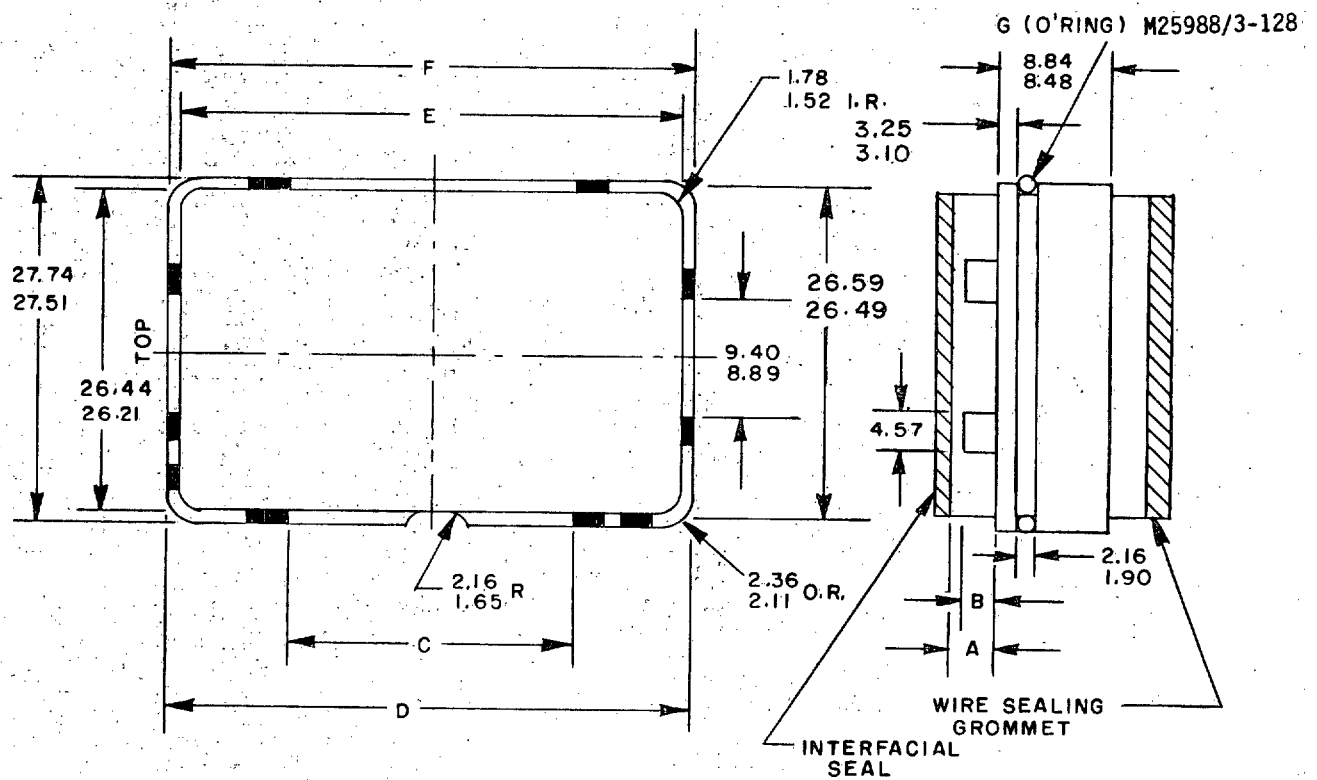

FIGURE 4. Insert interface dimensions for insert arrangements without size 22 contact cavities.

DOD-C-83527

SHELL STYLE	INSERT CAVITITES	A	B	C	D	E	F	G
PLUG	A.C.E	15.65	12.19	22.10	39.04	38.89	40.18	1.50 W
		15.44	11.56					X
RECEP	A.C.E	1.14	1.14	21.59	38.94	38.66	39.95	35.23 I.D.
		0.94	0.94					
PLUG	B.D.F	15.65	12.19	9.40	27.86	27.71	29.01	1.50 W
		15.44	11.56					X
RECEP	B.D.F	1.14	1.14	8.89	27.76	27.48	28.78	27.81 I.D.
		0.94	0.94					

MM	INCHES	MM	INCHES
0.94	.037	22.10	.810
1.14	.045	26.21	.032
1.50	.059	26.44	.041
1.52	.060	26.49	.043
1.65	.065	26.59	.047
1.78	.070	27.51	.083
1.90	.075	27.48	.082
2.11	.083	27.71	.091
2.16	.085	27.74	.092
2.36	.093	27.76	.093
3.10	.122	27.86	.097
3.25	.128	28.78	.133
4.57	.180	29.01	1.142
8.48	.334	38.66	1.522
8.84	.348	38.89	1.531
8.89	.35	39.04	1.537
9.40	.370	39.94	1.572
11.56	.455	39.95	1.573
12.19	.480	40.18	1.582
15.44	.608		
15.65	.616		
21.59	.85		

NOTES:

1. Interfacial seal applies to exposed contact inserts only (size 22 socket inserts or other size pin inserts).
2. Dimensions are in millimeters.
3. Inch equivalents are given for general information only.

FIGURE 4. Insert interface dimensions for insert arrangements without size 22 contact cavities - Continued.

DOD-C-83527

TABLE II. Contact size and wire range accommodations.

Wire barrel	Range of outside diameter of finished wire in mm (inches)	Wire gage range contact required to crimp
22	0.66 to 1.37 (.026) (.054)	AWG 22, 24, 26 <u>1/</u>
20	1.0 to 1.80 (0.39) (0.71)	AWG 20, 22
16	1.73 to 2.62 (.068) (.103)	AWG 16, 18, 20
12	2.46 to 3.43 (0.97) (.135)	AWG 12, 14
1 Coax (cavity size)	10.62 to 10.97 (.418) (.432)	M17/75-RG-214
5 Coax (cavity size)	4.85 to 5.49 (.191) (.216)	M17/28-RG-58 M17/84-RG-223
8 Concentric Twinax (cavity size)	3.15 to 3.40 (.129) (.134)	M17/176-0002

1/ AWG 24 and 26 shall not be used for airframe wiring.

3.4.3.3 Insert interchangeability. Connector inserts shall be interchangeable between shells of different configurations and shells supplied by other qualified manufacturers under this specification and applicable specification sheets.

3.4.3.4 Insert retention. Individual inserts shall be positively retained within the connector shell by mechanical means.

3.4.3.5 Contact retention. Crimp contacts shall be rear release and positively retained by the insert. The retention mechanism shall be contained in the insert. The contacts shall be free of devices which can be damaged during handling and usage.

3.4.3.6 Insert replaceability. Inserts shall be rear removable and are replaceable after removal of mechanical retainer. No tools other than a screwdriver and those tools in accordance with MIL-I-81969 shall be needed.

3.4.3.7 Insert contact loading.

3.4.3.7.1 Plug inserts. Inserts for use in plugs shall have cavities capable of being loaded with socket contacts, except cavities for size 22 contacts which shall accommodate pin contacts (see 3.1).

3.4.3.7.2 Receptacle inserts. Inserts for use in receptacles shall have cavities capable of being loaded with pin contacts, except cavities for size 22 contacts which shall accommodate socket contacts (see 3.1).

3.4.3.8 Sealing plugs. Sealing plugs, selected from MS27488, shall be available for unused contact cavities for class R connectors. Connectors shall pass all tests required herein with any quantity of the contact holes sealed with the plugs. The same sealing plug shall be used in both the plug and receptacle. Sealings plugs equal

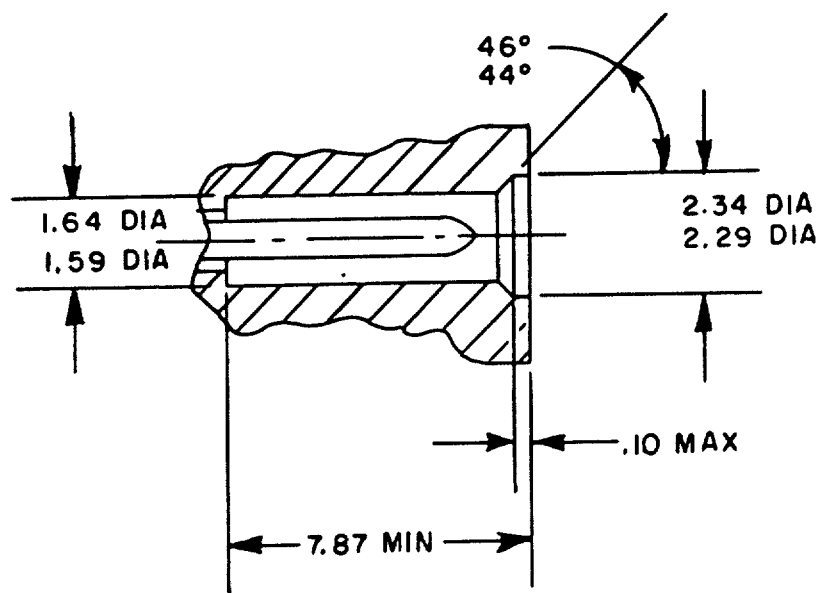

MM	INCHES
0.10	.004
1.59	.063
1.64	.065
2.29	.090
2.34	.092
7.87	.310

NOTES:

1. Dimensions are in millimeters.
2. Inch equivalents are given for general information only.

FIGURE 5. Size 22 pin contact cavity.

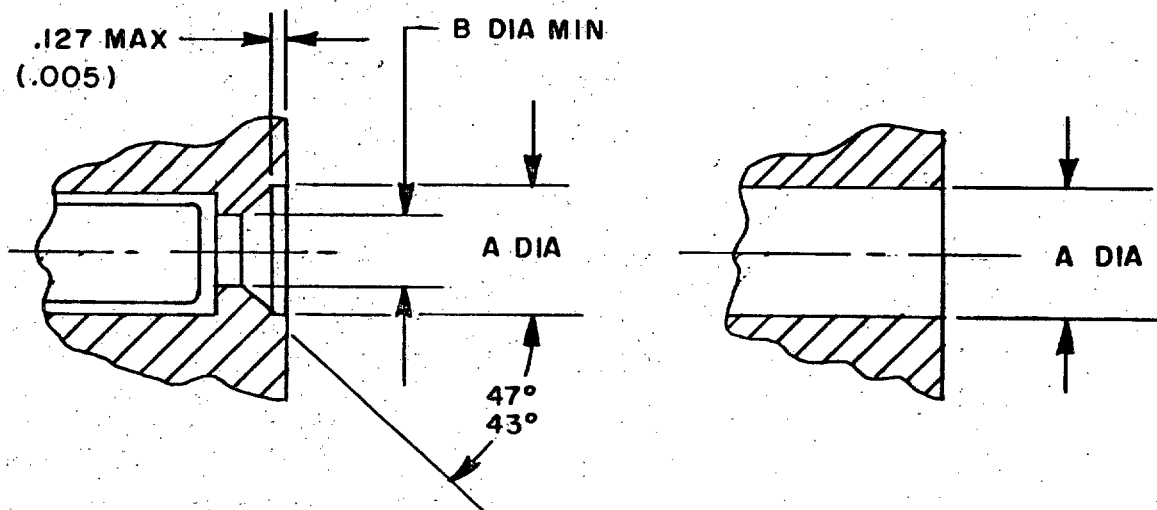

Socket Contact Cavity
All sizes except 1 Coax.

CONFIGURATION A

Socket Cavity Size
1 Coax.

CONFIGURATION B

CONTACT SIZE	A Dia.	B Dia.
20	2.67 (.105)	
	2.41 (.095)	1.27 (.05)
16	3.38 (.133)	
	3.12 (.123)	2.01 (.079)
12	4.57 (.180)	
	4.32 (.170)	2.51 (.099)
SIZE 1 COAX	3.07 (.121)	
	2.62 (.103)	
SIZE 5 COAX	7.29 (.287)	
	7.04 (.277)	5.72 (.225)
SIZE 8 TWINAX	7.49 (.295)	
	7.24 (.285)	5.84 (.230)

NOTES:

1. Dimensions are in millimeters.
2. Inch equivalents are given for general information only.
3. Inch equivalents are in parentheses.

FIGURE 6. Socket contact cavity.

DOD-C-83527

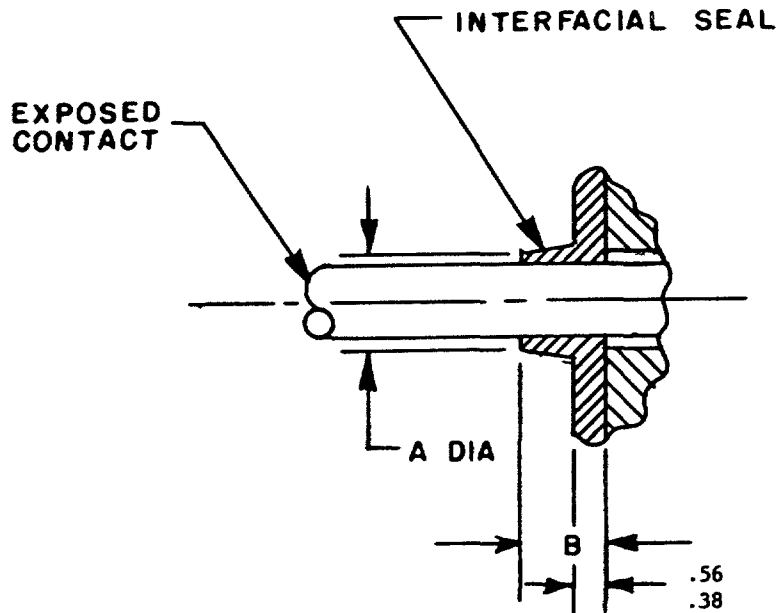

CONTACT	A Dia.	B Dia.
22 SOCKET	2.29 (.090)	1.75 (.069)
	2.13 (.084)	1.55 (.061)
20 PIN	1.83 (.072)	2.54 (.1)
	1.68 (.066)	2.29 (.090)
16 PIN	2.51 (.099)	2.67 (.105)
	2.34 (.092)	2.41 (.095)
12 PIN	3.33 (.131)	2.79 (.110)
	3.15 (.124)	2.54 (.1)
SIZE 1 COAX PIN	16.76 (.660)	2.41 (.095)
	14.22 (.560)	1.65 (.065)
SIZE 5 COAX PIN	7.01 (.276)	2.29 (.090)
	6.81 (.268)	2.03 (.080)
SIZE 8 TWINAX PIN	7.01 (.276)	2.67 (.105)
	6.81 (.268)	2.41 (.095)

NOTES:

1. Dimensions are in millimeters.
2. Inch equivalents are given for general information only.
3. Inch equivalents are in parentheses.

FIGURE 7. Exposed contact interfacial seal design.

DOD-C-83527

to 15 percent of the number of contacts, but not less than 1, shall be included in the unit package. Sealing plugs shall not be supplied for coaxial contact cavities. They must be obtained separately. For indirect shipments (shipments to non-government agencies) connectors may be ordered without sealing plugs (see 6.2).

3.4.3.9 Wire sealing members (rear grommet). The wire sealing member shall provide suitable sealing for overall wire diameters listed in table II and shall not be removable from the insert.

3.4.3.10 Contact cavity and interfacial seal design.

3.4.3.10.1 Size 22 pin contact cavity. Cavities for size 22 pin contacts shall be designed to protect the contacts from protruding beyond the front face of the rigid dielectric insert. Cavity configuration shall be per figure 5.

3.4.3.10.2 Socket contact cavity. Socket contact cavity (other than for size 22 contact) shall conform to the design of figure 6.

3.4.3.10.3 Interfacial seal. Interfacial seal for receptacle inserts shall be designed in accordance with figure 7.

3.4.4 Contact accommodation. Provisions are required to handle combinations of the following contacts as shown in the individual specification sheets.

- a. Contacts to include sizes 12, 16, 20, and 22.
- b. Coaxial contacts to include size 1 and 5 coax, and size 8 twinax.
- c. Size 22 contacts shall not be used with any other size contacts except size 1 coax.

The quantity of crimp contacts to be supplied with each connector unit package shall consist of a full complement of contacts plus 1 spare contact for each size used in the arrangement utilizing 26 contacts or less. For arrangements utilizing more than 26 contacts, 2 spare contacts of each size used in the arrangement shall be supplied. Spare coaxial and twinax contacts need not be supplied. For indirect shipments (shipments to non-government agencies), connectors may be ordered without contacts (see 6.2).

3.4.4.1 Contacts. Contacts shall be in accordance with MIL-C-39029/93 through MIL-C-39029/100.

3.4.4.2 Contact arrangement identification. The contact positions shall be permanently designated in contrasting color on the front face of the insert material and on the rear face of the wire sealing grommet. The interfacial markings of the inserts shall not be raised or recessed on any sealing surfaces and shall be in accordance with DOD-STD-1842.

3.4.4.3 Contact location. When tested in accordance with 4.7.2, the axial location of contacts from gaging surfaces of insert housing shall be as specified on figure 8.

3.4.5 Shell.

3.4.5.1 Retention system marking. The polarizing key retaining plate on both plug and receptacle shell shall be colored blue to indicate rear release contact retention system.

3.4.5.2 Shell design. The connector shall be of the solid shell design and shall be constructed to positively retain inserts. The configuration shall be as shown in the applicable specification sheet. The engaging skirts and surfaces shall be configured to align the shells while mating and to provide proper guidance for engagement of the pin and socket contacts.

DOD-C-83527

- a. The connector receptacle shall provide surface for the bottoming of the plug shell to ensure full connector mating.
- b. When the plug and receptacle are fully mated, the space between the adjacent flanges shall be a minimum of 10.16 and a maximum of 11.27 millimeters.
- c. Minimum contact exposure shall be maintained. Contacts shall not extend beyond the shell with the exception of the size 1 coax contact.
- d. Optional alignment ribs may be provided on the connector plug. The number of ribs and the spacing of the ribs is also optional. Ribs shall not be permitted on the connector receptacle.

3.4.5.3 Shell polarization. Shell polarization of the connector shall be accomplished by means of settable posts and keys positioned in accordance with figure 9. Polarizing post and key hole shall be as shown on figures 10 and 11. Polarization shall occur before any contacts enter the mating insulator or coaxial contacts begin engagement. The connector shells shall have a minimum of 99 polarizing positions and shall use the code defined by figure 12. All plugs and all receptacles shall be shipped with the posts and keys in position 01 (see figure 12). Each other position shall be selectable by the user without disassembly of the connector.

3.4.5.4 EMI seal. An EMI seal shall be provided around each insert housing on the plug shell to ensure electrical grounding to the mating receptacle shell and to meet the EMI requirements specified herein. The EMI seal shall form an integral part of the plug shell, and shall in connector mating make contact to receptacle shell prior to electrical contact mating.

3.4.5.5 Peripheral environmental seal. A resilient peripheral seal shall be provided around each insert housing of the plug shell to provide environmental peripheral sealing between mating shells. Peripheral seal shall be lubricated with Parker "Super-0-Lube" or equivalent.

3.4.5.6 Connector mating sequence. Connector mating sequence shall be as follows:

Shells - polarizing keys - EMI seal - contacts

Peripheral seal engagement may occur anytime between shells and contacts mating.

3.4.6 Backshell hardware. Backshells shall be in accordance with MIL-C-85049 (see 6.4.2).

3.5 Performance requirements. Connectors, inserts, shells, backshells, contacts, and accessories shall be designed to meet the performance requirements specified herein when tested in accordance with the specified methods of section 4.

3.5.1 Examination of product. Contacts, inserts, shells, backshells, connectors, and accessories shall be examined as specified in 4.7.1, and shall meet the requirements indicated herein.

3.5.2 Mating and separating forces. When tested as specified in 4.7.3 the maximum force needed to mate or separate counterpart plugs and receptacles shall not exceed 315 newtons for size 2 or 675 newtons for size 3 and 1035 newtons for size 4.

3.5.3 Maintenance aging, contact insertion and removal force. After testing as specified in 4.7.4, connectors shall be capable of meeting the performance requirements of this specification. After testing, the individual contact insertion and removal forces shall not exceed the values listed in table III. Failure to complete these operations shall be cause for rejection.

3.5.4 Contact retention. When tested as specified in 4.7.5, the axial displacement of the contacts shall not exceed 0.3 mm. No dislodging or damage to contacts or inserts shall result.

DOD-C-83527

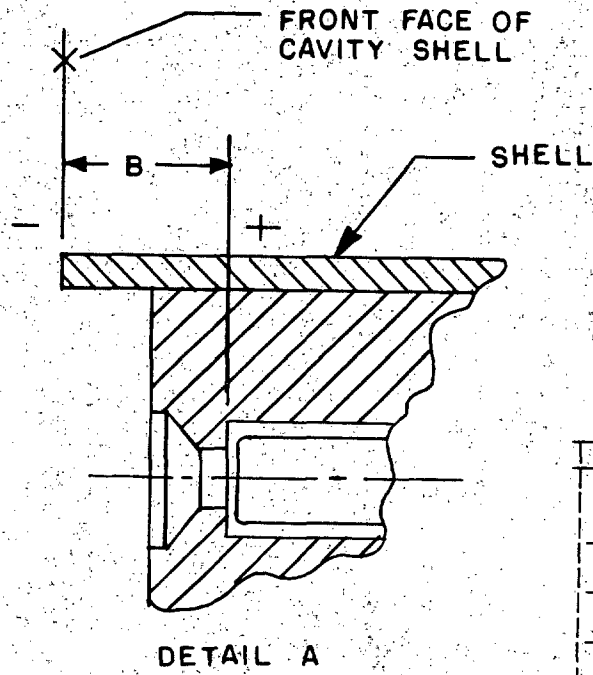
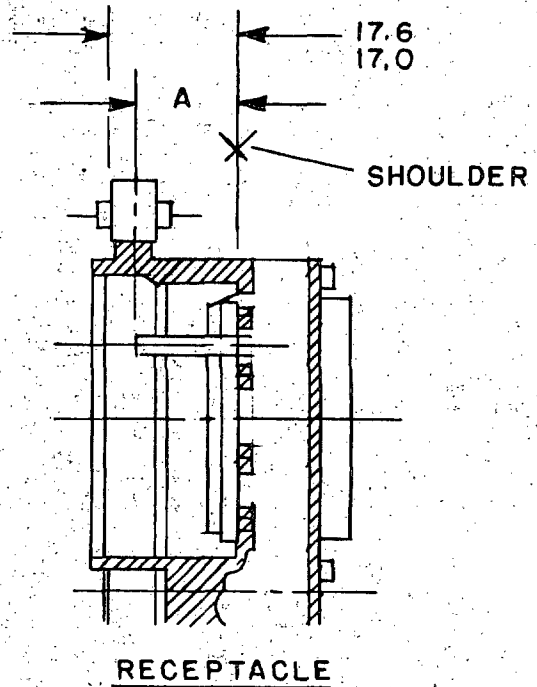
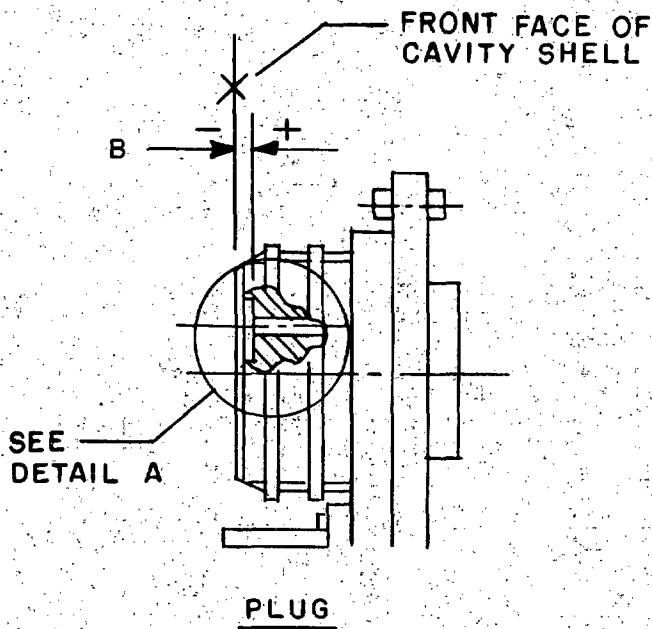

MM	INCHES	MM	INCHES
0.838	.033	9.19	.362
1.52	.060	9.22	.363
2.03	.080	9.37	.369
2.08	.082	9.80	.386
2.23	.088	9.83	.387
2.59	.102	10.06	.396
2.79	.110	10.11	.398
2.95	.116	10.82	.426
3.00	.118	11.81	.465
3.23	.127	11.96	.471
4.01	.158	12.98	.511
8.10	.319	13.06	.514
8.61	.339	17.0	.670
		17.6	.693

CONTACT			
SIZE	TYPE	B MM	A MM
22	PIN	4.01/3.00	-
	SOCKET	-	9.83/9.22
20	PIN	-	9.37/8.10
	SOCKET	2.59/1.52	-
16	PIN	-	13.06/11.81
	SOCKET	3.28/2.03	-
12	PIN	-	12.98/11.96
	SOCKET	3.23/2.23	-
8	PIN	-	10.06/9.19
	SOCKET	2.95/2.08	-
5	PIN	-	9.80/8.61
COAX	SOCKET	2.79/2.24	-
1	PIN	-	10.82/10.11
COAX	SOCKET	+ .838 / - .838	-

NOTES:

1. Dimensions are in millimeters.
2. Inch equivalents are given for general information only.
3. All measurements are to the tip or front face of contacts.

FIGURE 8. Contact location.

DOD-C-83527

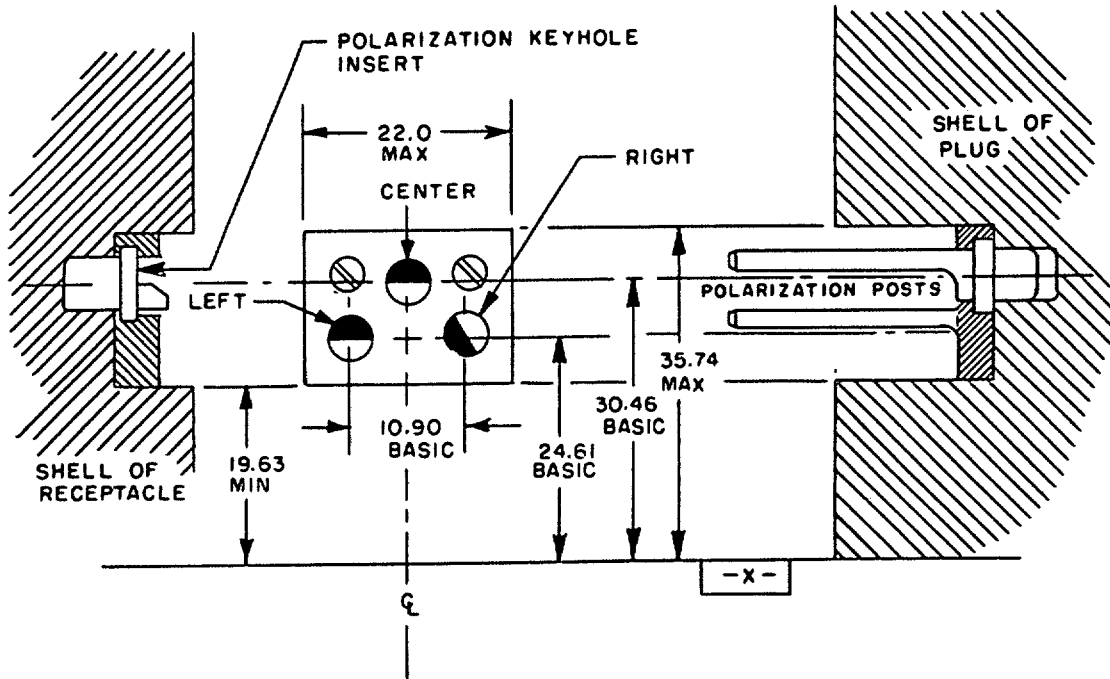

Polarization Coding:

Darkened segment represents extended part of post in plug.
 Light segment represents key hole in receptacle.
 Example reads 1, 1, 5.

MM	INCHES
10.90	.429
19.63	.773
22.0	.866
24.61	.969
30.46	1.199
35.74	1.407

NOTES:

1. Dimensions are in millimeters.
2. Inch equivalents are given for general information only.
3. 1, 1, 5 in plug mates with 6, 4, 4 in receptacle.

FIGURE 9. Shell polarization posts and keys (as installed).

DOD-C-83527

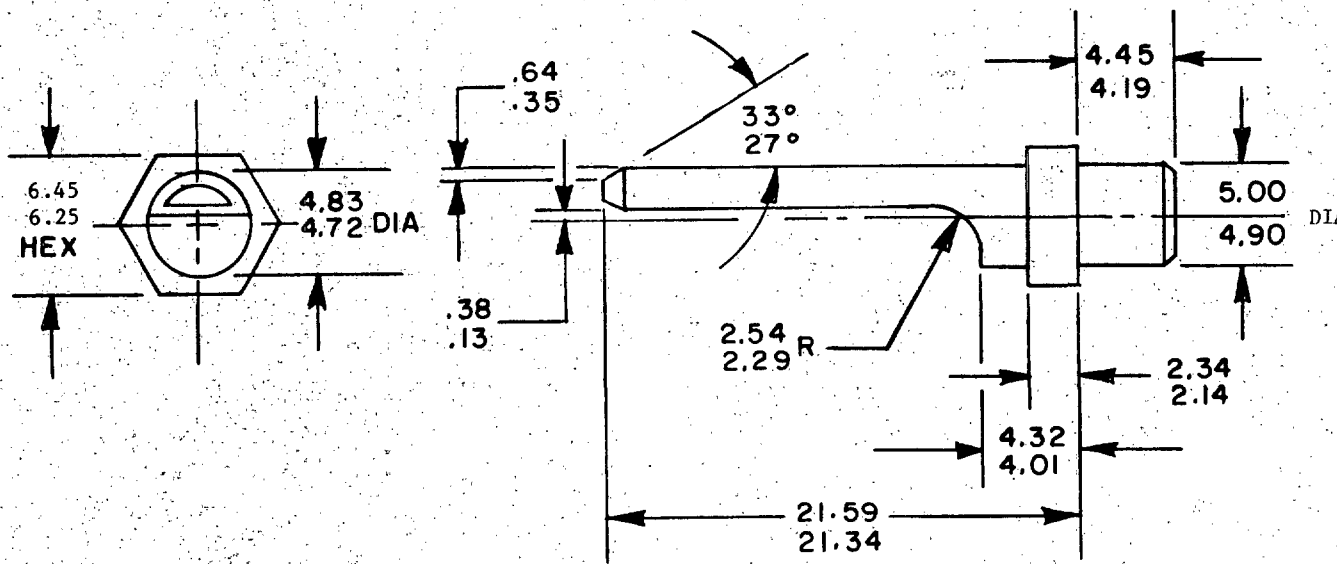

MM	INCHES	MM	INCHES
0.13	.005	4.32	.170
0.35	.014	4.45	.175
0.38	.015	4.72	.186
0.64	.025	4.83	.190
2.14	.084	4.90	.193
2.29	.090	5.00	.197
2.34	.092	6.45	.254
2.54	.158	6.65	.262
4.19	.165	21.34	.841
		21.59	.85

NOTES:

1. Dimensions are in millimeters.
2. Inch equivalents are given for general information only.

FIGURE 10. Plug polarizing post.

DOD-C-83527

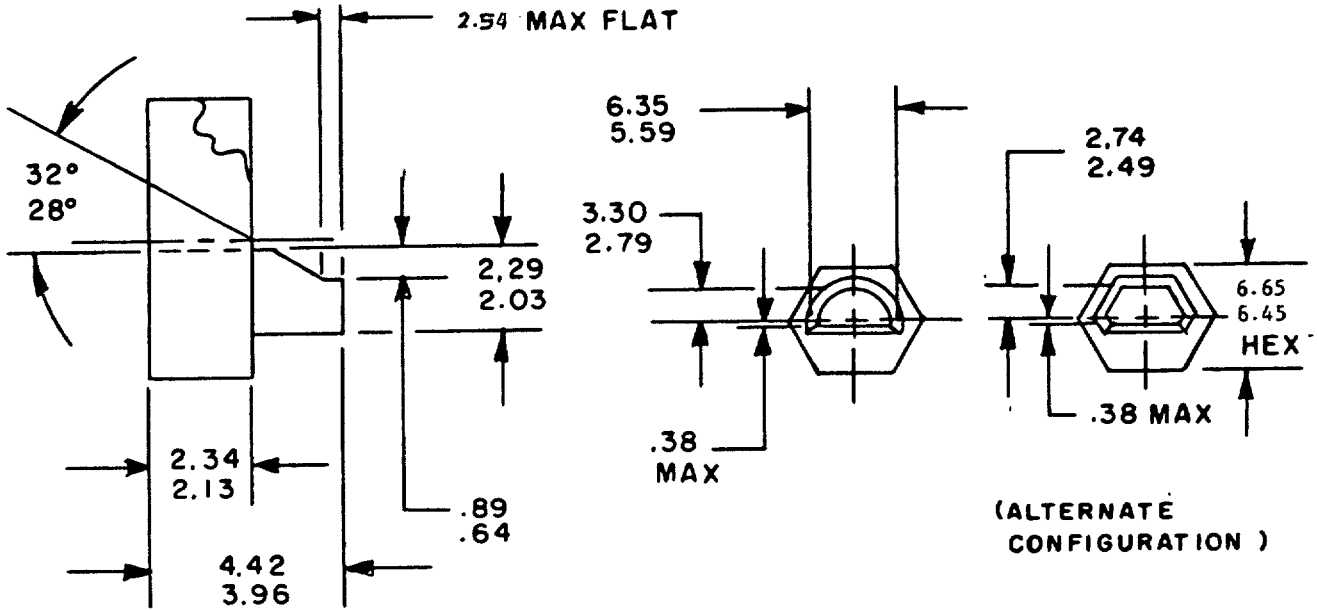

MM	INCHES	MM	INCHES
0.254	.01	2.34	.092
0.38	.015	2.49	.098
0.64	.025	2.74	.108
0.645	.025	2.79	.110
0.665	.026	3.30	.130
0.89	.035	3.96	.156
2.03	.080	4.42	.174
2.13	.084	5.59	.220
2.29	.090	6.35	.25

NOTES:

1. Dimensions are in millimeters.
2. Inch equivalents are given for general information only.

FIGURE 11. Receptacle key hole polarizing insert.

DOD-C-83527

Polarization positions.

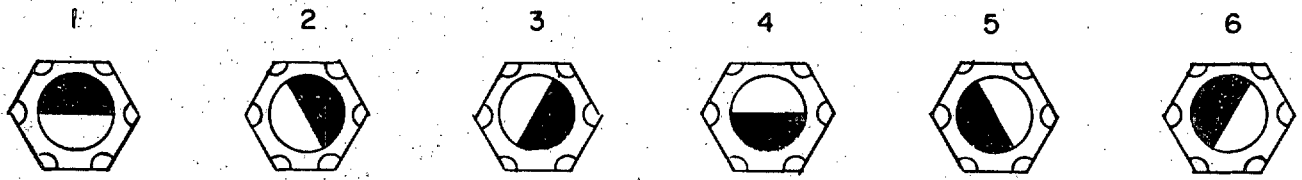

PLUG				RECEPTACLE				PLUG				RECEPTACLE			
POSTION	LEFT POST	CENTER POST	RIGHT POST	POSTION	LEFT KEY	CENTER KEY	RIGHT KEY	POSTION	LEFT POST	CENTER POST	RIGHT POST	POSTION	LEFT KEY	CENTER KEY	RIGHT KEY
00	-	-	-	00	-	-	-	50	2	2	5	50	6	3	3
01	1	1	1	01	4	4	4	51	3	2	5	51	6	3	2
02	2	1	1	02	4	4	3	52	4	2	5	52	6	3	1
03	3	1	1	03	4	4	2	53	5	2	5	53	6	3	6
04	4	1	1	04	4	4	1	54	6	2	5	54	6	3	5
05	5	1	1	05	4	4	6	55	1	2	4	55	1	3	4
06	6	1	1	06	4	4	5	56	2	2	4	56	1	3	3
07	1	1	6	07	5	4	4	57	3	2	4	57	1	3	2
08	2	1	6	08	5	4	3	58	4	2	4	58	1	3	1
09	3	1	6	09	5	4	2	59	5	2	4	59	1	3	6
10	4	1	6	10	5	4	1	60	6	2	4	60	1	3	5
11	5	1	6	11	5	4	6	61	1	2	3	61	2	3	4
12	6	1	6	12	5	4	5	62	2	2	3	62	2	3	3
13	1	1	5	13	6	4	4	63	3	2	3	63	2	3	2
14	2	1	5	14	6	4	3	64	4	2	3	64	2	3	1
15	3	1	5	15	6	4	2	65	5	2	3	65	2	3	6
16	4	1	5	16	6	4	1	66	6	2	3	66	2	3	5
17	5	1	5	17	6	4	6	67	1	2	2	67	3	3	4
18	6	1	5	18	6	4	5	68	2	2	2	68	3	3	3
19	1	1	4	19	1	4	4	69	3	2	2	69	3	3	2
20	2	1	4	20	1	4	3	70	4	2	2	70	3	3	1
21	3	1	4	21	1	4	2	71	5	2	2	71	3	3	6
22	4	1	4	22	1	4	1	72	6	2	2	72	3	3	5
23	5	1	4	23	1	4	6	73	1	3	1	73	4	2	4
24	6	1	4	24	1	4	5	74	2	3	1	74	4	2	3
25	1	1	3	25	2	4	4	75	3	3	1	75	4	2	2
26	2	1	3	26	2	4	3	76	4	3	1	76	4	2	1
27	3	1	3	27	2	4	2	77	5	3	1	77	4	2	6
28	4	1	3	28	2	4	1	78	6	3	1	78	4	2	5
29	5	1	3	29	2	4	6	79	1	3	6	79	5	2	4
30	6	1	3	30	2	4	5	80	2	3	6	80	5	2	3
31	1	1	2	31	3	4	4	81	3	3	6	81	5	2	2
32	2	1	2	32	3	4	3	82	4	3	6	82	5	2	1
33	3	1	2	33	3	4	2	83	5	3	6	83	5	2	6
34	4	1	2	34	3	4	1	84	6	3	6	84	5	2	5
35	5	1	2	35	3	4	6	85	1	3	5	85	6	2	4
36	6	1	2	36	3	4	5	86	2	3	5	86	6	2	3
37	1	2	1	37	4	3	4	87	3	3	5	87	6	2	2
38	2	2	1	38	4	3	3	88	4	3	5	88	6	2	1
39	3	2	1	39	4	3	2	89	5	3	5	89	6	2	6
40	4	2	1	40	4	3	1	90	6	3	5	90	6	2	5
41	5	2	1	41	4	3	6	91	1	3	4	91	1	2	4
42	6	2	1	42	4	3	5	92	2	3	4	92	1	2	3
43	1	2	6	43	5	3	4	93	3	3	4	93	1	2	2
44	2	2	6	44	5	3	3	94	4	3	4	94	1	2	1
45	3	2	6	45	5	3	2	95	5	3	4	95	1	2	6
46	4	2	6	46	5	3	1	96	6	3	4	96	1	2	5
47	5	2	6	47	5	3	6	97	1	3	3	97	2	2	4
48	6	2	6	48	5	3	5	98	2	3	3	98	2	2	3
49	1	2	5	49	6	3	4	99	3	3	3	99	2	2	2

NOTES:

1. Darkened portion indicates extended part of post in plug. Light portion indicates key hole in receptacle.
2. Mating faces shown with top up.

FIGURE 12. Polarization positions.

DOD-C-83527

TABLE III. Insertion/removal forces.

Contact size	Axial loads (newtons)	
	Insertion	Removal
22	45	36
20	67	45
16	90	67
12	112	90
Coaxial contacts	135	112

3.5.5 Altitude-ambient temperature. When tested as specified in 4.7.6, the connectors shall meet the dielectric withstanding voltage specified in 3.5.13 and the insulation resistance specified in 3.5.11.

3.5.6 Temperature cycling. When tested as specified in 4.7.7, connectors shall meet the performance requirements of the remaining test sequence. There shall be no damage detrimental to the operation of the connectors.

3.5.7 Insert retention. When tested as specified in 4.7.8, connectors shall retain their inserts in their proper location in the shell. The maximum axial displacement allowed shall be .25 mm. Evidence of cracking breaking, separation from the shell, or loosening shall be cause for rejection of parts.

3.5.8 Salt spray (corrosion). After testing as specified in 4.7.9, unmated connectors and individual contact samples shall show no exposure of basic metal (due to corrosion) which will adversely affect performance.

3.5.9 Contact resistance. When tested as specified in 4.7.10, contacts in the mated condition shall meet the contact resistance requirements of table IV.

TABLE IV. Contact resistance requirements.

Contact size	Wire size AWG	Test current (amps)	Millivolt drop maximum	
			After corrosion, temperature durability, or current cycling	All others
12	12	23.0	51	42
16	16	13.0	59	49
20	20	7.5	65	55
22	22	5.0	55	40
22	26	2.0	40	25
22	24	3.0	45	30

3.5.10 Seal leakage. When tested in accordance with 4.7.11, mated connectors shall have a minimum insulation resistance of 1000 megohms and shall withstand a dielectric test voltage of 1,500 volts, rms, 60 Hz, with a maximum leakage current of 1 milliampere.

DOD-C-83527

3.5.11 Insulation resistance at ambient temperature. When tested as specified in 4.7.12.1, the insulation resistance between any pair of contacts and between any contact and the shell shall be greater than 1,000 megohms.

3.5.12 Insulation resistance at elevated temperature. When tested as specified in 4.7.12.2, the insulation resistance between any pair of contacts and between any contact and the shell shall be greater than 1,000 megohms.

3.5.13 Dielectric withstanding voltage. When tested as specified in 4.7.13.1 and 4.7.13.2 connectors shall show no evidence of flashover or breakdown.

3.5.14 Durability. When tested as specified in 4.7.14, connectors shall show no physical damages detrimental to the mating and performance of the connector. Exposure of base metal on contact surfaces shall be grounds for rejection. Immediately after the test, the connectors shall meet the requirements for insulation resistance, dielectric withstanding voltage and connector mating and unmating forces.

3.5.15 Random vibration. When tested as specified in 4.7.15, a current discontinuity of 1 microsecond or more, evidence of cracking, breaking, or loosening of parts shall be cause for rejection.

3.5.16 Shock. When tested as specified in 4.7.16, a current discontinuity of 1 microsecond or more, evidence of cracking, breaking, or loosening of parts shall be cause for rejection.

3.5.17 Static load. When tested as specified in 4.7.17 during and after the application of the specified forces, connectors shall show no evidence of damage detrimental to their normal operation nor shall there be any interruption of electrical continuity. The connectors shall withstand a compressive load of 11,025 newtons, a vertical load of 4,950 newtons, and a side load of 3,675 newtons.

3.5.18 Shell-to-shell conductivity. When tested as specified in 4.7.18, plugs and receptacles shall be electrically conductive. The maximum potential voltage between the shells of the connector pair shall not exceed 2.5 millivolts.

3.5.19 Humidity. When tested as specified in 4.7.19, the insulation resistance shall be 1,000 megohms or greater after conditioning. The connector pair shall have an insulation resistance greater than 1,000 megohms 1 to 2 hours after humidity, and after 24 hours of conditioning at room ambient. Connectors shall show no deterioration or damage that will adversely affect performance.

3.5.20 EMI shielding. When tested in accordance with 4.7.20, the EMI shielding capabilities of mated shells shall not be less than that specified in table V at the specified frequencies.

TABLE V. EMI shielding effectiveness.

Frequency MHz	Leakage Attenuation (dB)	Frequency MHz	Leakage Attenuation (dB)
100	90	400	87
200	88	800	85
300	88	1,000	85

3.5.21 Ozone exposure. When tested as specified in 4.7.21, the connectors shall show no evidence of cracking of dielectric material, deterioration of resilient seals, or other damage due to ozone exposure that will adversely affect performance.

DOD-C-83527

3.5.22 Fluid immersion.

- a. Seals. After immersion in the fluids as specified in 4.7.22, connectors shall unmate and mate properly and resilient materials shall not swell to the extent that cracks and tears appear. There shall be no evidence of material reversion. Shells, plating, and dielectric materials shall show no evidence of deterioration, distortion, or material reversion.
- b. Retention system. After immersion in the fluids as specified in 4.7.23, contact retention shall meet the requirements of 3.5.4 and the insert retention capability shall meet the requirements of 3.5.7.

3.5.23 Altitude immersion. When tested in accordance with 4.7.25, the mated connector shall meet the requirements of insulation resistance and dielectric withstanding voltage as specified in 3.5.11 and 3.5.13.

3.5.24 Contact walk-out. When tested as specified in 4.7.24, contacts shall not become dislodged from their normal position.

3.5.25 Installing and removal tool abuse. When tested as specified in 4.7.26 there shall be no evidence of damage to the contacts, the connector inserts, or the contact retaining mechanism.

3.5.26 Contact stability (sizes 22, 20, 16, and 12 crimp contacts). When tested in accordance with 4.7.27, the total displacement of the contact tip end shall not exceed 0.25 mm for the size 22 socket contact, 1.0 mm for the size 20 pin contact, and 1.5 mm for the size 16 and size 12 pin contact.

3.5.27 Temperature life with contact loading. When subjected to the test specified in 4.7.28, the contacts shall maintain their previously measured location with not more than 0.3 mm change.

3.6 Interchangeability. The connector plug, receptacles, inserts, contacts, and accessories supplied to this specification shall meet the requirements of the applicable specification sheet and shall be completely interchangeable with the components having the same part numbers but supplied by another qualified connector manufacturer.

3.7 Marking.

3.7.1 Connectors and accessories. Connectors and accessories shall be marked in accordance with method 1 of MIL-STD-1285, and shall include the military part number (see 3.1), the manufacturer's name or code symbol, Manufacturers Federal Supply Code (FSCM), and date code. The characters shall be a minimum of 1.5 millimeter in height. If used, metal stamping shall be accomplished before plating. Connector shell marking and insert marking shall remain legible after completion of the tests specified in 4.5.

3.7.2 Insert identification. The military part number, manufacturers identification, manufacturers federal supply code (FSCM), and date code shall appear on the side of the insert in a contrasting color.

3.7.3 Contact designation. Contact locations shall be designated with identifiable characters as indicated on the applicable specification sheet. All positions shall be identified on the front and rear faces of the insert except where space limitations make this impracticable. Location of contact identifying characters shall be in close proximity to the holes but need not be placed exactly where indicated on the standard. Inserts containing size 22 contacts shall be marked with a 5 x 5 grid pattern rear face in accordance with paragraph 5.2 of DOD-STD-1842.

3.8 Workmanship. The connector shall be fabricated in a manner such that the criteria for appearance, fit, and adherence to specified tolerances are observed. Particular attention shall be given to neatness and thoroughness of marking parts, plating, welding, soldering, riveting, staking, bonding, and freedom of parts from burrs and sharp edges.

DOD-C-83527

4. QUALITY ASSURANCE PROVISIONS

4.1 Responsibility for inspection. Unless otherwise specified in the contract or purchase order, the contractor is responsible for the performance of all inspection requirements as specified herein. Except as otherwise specified in the contract or purchase order, the contractor may use his own or any other facilities suitable for the performance of the inspection requirements specified herein, unless disapproved by the Government. The Government reserves the right to perform any of the inspection set forth in the specification where such inspections are deemed necessary to assure supplies and services conform to prescribed requirements.

4.1.1 Test equipment and inspection facilities. Test and measuring equipment and inspection facilities of sufficient accuracy, quality, and quantity to permit performance of the required inspection shall be established and maintained by the contractor. The establishment and maintenance of a calibration system to control the accuracy of the measuring and test equipment shall be in accordance with MIL-STD-45662.

4.1.2 Reliability assurance program. A reliability assurance program shall be established and maintained in accordance with MIL-STD-790. Evidence of such compliance shall be verified by the qualifying activity of this specification as a prerequisite for qualification and continued qualification.

4.1.3 Assembly plants. Assembly plants must be listed on or approved for listing on the applicable Qualified Products List. The qualified connector manufacturer shall certify that the assembly plant is approved for the assembly and distribution of the manufacturer's parts. The assembly plant shall use only piece parts supplied by the qualified connector manufacturer. No testing other than visual examination is required for certified piece parts obtained from the qualified connector manufacturer, except when there is cause for rejection. All assemblies produced at the assembly plant shall be subjected to examination of product to assure that the assembly process conforms with that established at the qualified manufacturing plant. Quality control requirements, including Government inspection surveillance, shall be the same as required for the qualified connector manufacturer.

4.1.4 Hydrolytic stability. Certification of requirement 47 of MIL-STD-454 is required (see 3.3.1.2).

4.1.5 Fungus resistance certification. Certification of requirement 4 of MIL-STD-454 is required (see 3.3.3).

4.2 Classification of inspections. The inspections specified herein are classified as follows:

- a. Qualification inspection (see 4.4).
- b. Quality conformance inspection (see 4.5).

4.3 Inspection conditions. Unless otherwise specified, all inspections shall be performed in accordance with the test conditions specified in the "GENERAL REQUIREMENTS" of MIL-STD-1344 and MIL-STD-202.

4.4 Qualification inspection. Qualification inspection shall be performed at a laboratory acceptable to the Government (see 6.3) on sample units produced with equipment and procedures normally used in production.

4.4.1 Sample size. A minimum of 12 completely assembled plugs and receptacles of the class (1.2.1) with the insert arrangement of the largest size connector of the specification sheet (see 3.1) for which qualification is desired, shall be subjected to the examinations and tests, in the sequence shown in table VI. The connectors shall have a full complement of contacts and all contact sizes shall be represented. The samples subjected to qualification testing shall be provided with counterpart connectors for those tests requiring mating assemblies. The counterpart connectors provided for this purpose shall be new, previously qualified connectors or new connectors submitted for qualification testing. Manufacturers not producing mating connectors shall submit substantiating, certification data that tests were performed with qualified counterpart connectors. The samples shall be taken from a production run and shall be produced with equipment and procedures normally used in production.

DOD-C-83527

4.4.2 Preparation of samples. Connectors shall be wired with approximately 600 mm \pm 20% of wire conforming to MIL-W-22759/43, MIL-C-17. Half of the connectors of each type shall be wired with the maximum wire size and the remainder shall be wired with the minimum wire size specified in table II. Connectors wired with minimum diameter wire shall be divided equally between groups I and II. Connectors wired with maximum diameter wire shall be divided equally between groups III and IV. Termination of wires to contacts shall be accomplished with a MIL-C-22520 crimping tool (see 3.1). Different insert combinations and connectors may be used to include these wire sizes.

4.4.3 Qualification of contacts. If a manufacturer submits qualification samples of DOD-C-83527 connectors, contacts supplied with the samples shall be either qualified to MIL-C-39029 or contacts that have been submitted to the qualifying activity for approval.

4.4.4 Failures. Any failure shall be cause for refusal to grant qualification.

4.4.5 Retention of qualification. To retain qualification, the contractor shall forward a report at least every 12 months to the qualifying activity. The qualifying activity shall establish the initial reporting date. The report shall consist of a summary of the results of tests performed for group B inspection including the number and mode of failures. The summary shall include results of all group A inspection tests performed and completed during the reporting period. If the summary of the test results indicates nonconformance with specification requirements, and corrective action acceptable to the qualifying activity has not been taken, action may be taken to remove the failing product from the qualified products list. Failure to submit the report within 30 days after the end of each reporting period may result in loss of qualification for the product. In addition to the periodic submission of inspection data, the contractor shall immediately notify the qualifying activity if at any time during the reporting period the inspection data indicates failure of the qualified product to meet the requirements of this specification.

In the event that no production occurred during the reporting period, a report shall be submitted certifying that the company still has the capabilities and facilities necessary to produce the item. If during two consecutive reporting periods there has been no production, the manufacturer may be required, at the discretion of the qualifying activity, to submit the products (a representative product of each connector) to testing in accordance with the qualification inspection requirements.

4.5 Quality conformance inspection.

4.5.1 Inspection of product for delivery. Inspection of product for delivery shall consist of group A inspection.

4.5.1.1 Inspection lot. An inspection lot shall consist of all connectors covered by one specification sheet, produced under essentially the same conditions, and offered for inspection at one time.

4.5.2. Group A inspection. Each connector shall be subjected to the individual tests shown in table VII. For group A inspection, the documentation and standard test conditions of MIL-STD-1344 do not apply.

TABLE VI. Qualification test sequence.

Test/Group	I	II	III	IV	Requirement paragraph	Test method paragraph
Examination of product	X	X	X	X	3.5.1	4.7.1
Nonmagnetic material	X	X	X	X	3.3.2	4.7.29
Altitude-ambient temperature	X				3.5.5	4.7.6
Insulation resistance (Ambient temperature)	X	X			3.5.11	4.7.12.1
Insulation resistance (Elevated temperature)	X	X			3.5.12	4.7.12.2
Dielectric withstand voltage (both)	X	X			3.5.13	4.7.13.1 and .2

DOD-C-83527

TABLE VI. Qualification test sequence - Continued.

Test/Group	I	II	III	IV	Requirement paragraph	Test method paragraph
Mating/separating forces	X	X	X	X	3.5.2	4.7.3
Maintainence aging, contact insertion and removal forces				X	3.5.3	4.7.4
Temperature cycling	X	X		X	3.5.6	4.7.7
Dielectric withstand voltage (Sea level)	X	X			3.5.13	4.7.13.1
Humidity		X			3.5.19	4.7.19
Insulation resistance (Ambient temperature)		X			3.5.11	4.7.12.1
Insulation resistance (Elevated temperature)		X			3.5.12	4.7.12.2
Random vibration	X	X			3.5.15	4.7.15
Static load			X		3.5.17	4.7.17
Shock	X				3.5.16	4.7.16
Durability	X		X		3.5.14	4.7.14
Insulation resistance (Ambient temperature)		X	X		3.5.11	4.7.12.1
Dielectric withstand voltage (Sea level)			X		3.5.13	4.7.13.1
Salt spray (Corrosion)		X			3.5.8	4.7.9
Seal Teakage	X				3.5.10	4.7.11
Contact resistance	X	X		X	3.5.9	4.7.10
Insulation resistance (Ambient temperature)	X				3.5.11	4.7.12.1
Insulation resistance (Elevated temperature)	X				3.5.12	4.7.12.2
Dielectric withstand voltage (Both)	X				3.5.13	4.7.13.1 and .2
Shell-to-shell conductivity				X	3.5.18	4.7.18
EMI shielding				X	3.5.20	4.7.20
Maintance aging, contact insertion, and removal forces				X	3.5.3	4.7.4
Altitude immersion		X			3.5.23	4.7.25
Contact walkout (one connector)			X		3.5.24	4.7.24
Ozone exposure	X				3.5.21	4.7.21
Installing and removal tool abuse	X				3.5.25	4.7.26
Contact stability		X			3.5.26	4.7.27
Temperature life with contact loading			X		3.5.27	4.7.28
Fluid immersion ^{1/}	X	X	X	X	3.5.22	4.7.22
Contact retention	X	X	X	X	3.5.4	4.7.5
Insert retention	X	X	X	X	3.5.7	4.7.8
Examination of product	X	X	X	X	3.5.1	4.7.1

^{1/} Test samples shall be divided into twelve subgroups and each subgroup shall be exposed to a different fluid.

4.5.2.1 Visual examination. Each connector shall be visually examined for completeness, workmanship, and identification requirements. Attention shall be given to those assemblies that require a seal, to determine the condition of that seal. Seals missing, twisted, buckled, kinked, or damaged in any way shall be cause for rejection.

DOD-C-83527

TABLE VII. Group A inspection.

Group A inspection - Individual tests
Visual examination - 100% inspection per 4.5.2.1
Insulation resistance (ambient temperature) - 100% per 4.7.12.1 <u>1/</u> <u>2/</u>
Dielectric withstanding voltage (sea level) - 100% per 4.7.13.1 <u>1/</u>

- 1/ The manufacturer may use in-process controls for this requirement.
2/ Test between two adjacent contacts and between two peripheral contacts and the shell.

4.5.3 Periodic inspection. Periodic inspection shall consist of groups B and C inspection. Except where the results of this inspection show noncompliance with the applicable requirements (4.5.3.1.4), delivery of products which have passed Group A shall not be delayed pending the results of periodic inspections.

4.5.3.1 Group B inspection. Group B inspection shall consist of the examination and tests specified in table VIII, in the order shown, and shall be made on sample units which have been subjected to and have passed the group A inspection. For group B inspection, the documentation and standard test conditions of MIL-STD-1344 do not apply.

4.5.3.1.1 Sampling plan. Sample connectors consisting of two mated pairs of each connector for which retention qualification is desired shall be selected every 24 months. Upon passing this inspection two consecutive times, the contractor may select sample connectors every 36 months. If production of a particular part number is not current, the group B tests must take place at the time production is resumed. The testing shall revert to the original schedule which is applied to a newly qualified product. The sampling plan shall be in accordance with MIL-STD-105 for special inspection S-4. Major and minor defects shall be as defined in MIL-STD-105. The AQL shall be as specified in table VIII.

TABLE VIII. Group B inspection.

Group B inspection - sampling tests	Test paragraph	AQL
Examination of product Major Minor	4.7.1	0.25 <u>1/</u> <u>3/</u> 1.00 <u>1/</u> <u>3/</u>
Mating and separating forces	4.7.3	
Contact resistance	4.7.14	<u>2/</u>

- 1/ The manufacturer may use in-process controls for this requirement.
2/ Select sample connectors in accordance with the AQL shown. Test 3 contacts in each sample connector.
3/ Major features are defined as all dimensions related to true positioning and locations of inserts and contacts. All other dimensions are minor.

D00-C-83527

4.5.3.1.2 Failures. If any sample units fail to pass group B inspection, the entire sample shall be considered to have failed.

4.5.3.1.3 Disposition of sample units. Sample units which have been subjected to group B inspection shall not be delivered on the contract.

4.5.3.1.4 Noncompliance. If a sample fails to pass group B inspection, the manufacturer shall notify the qualifying activity and the cognizant inspection activity of such failure and take corrective action on the materials or processes, or both, as warranted, and on all units of product which can be corrected and which were manufactured under essentially the same materials and processes, and which are considered subject to the same failure. Acceptance and shipment of the product shall be discontinued until corrective action, acceptable to the qualifying activity has been taken. After the corrective action has been taken, group B inspection shall be repeated on additional sample units (all inspections, or the inspection which the original sample failed, at the option of the qualifying activity). Group A inspection may be reinstated; however, final acceptance and shipment shall be withheld until the group B inspection has shown that the corrective action was successful. In the event of failure after inspection, information concerning the failure shall be furnished to the cognizant inspection activity and the qualifying activity.

4.5.3.2 Group C inspection. Group C periodic test shall be performed on a 48 month basis. The qualifying activity shall specify the sample size for these tests. Samples submitted for group C testing shall have passed groups A and B inspection. Group C tests shall be as specified in table IX.

TABLE IX. Group C inspection.

Inspection	Requirement paragraph	Test paragraph
Durability	3.5.14	4.7.14
Vibration	3.5.15	4.7.15
Salt spray	3.5.8	4.7.9
Altitude immersion	3.5.23	4.7.25

4.5.3.2.1 Failures. If one or more sample units fail to pass group C inspection, the sample shall be considered to have failed.

4.5.3.2.2 Disposition of sample units. Sample units which have been subjected to group C inspection shall not be delivered on the contract or purchase order.

4.5.3.2.3 Noncompliance. If a sample fails to pass group C inspection, the manufacturer shall take corrective action on the materials or processes or both, as warranted, and on all units of product which are to be corrected and which were manufactured with essentially the same materials, processes, etc., and which are considered subject to the same failure. Acceptance and shipment of the product shall be discontinued until corrective action acceptable to the qualifying activity has been taken. After the corrective action has been taken, group C inspection shall be repeated on additional sample units (all inspections, or the inspection which the original sample failed, at the option of the qualifying activity). Groups A and B inspections may be reinstated; however, final acceptance shall be withheld until the group C reinspection has shown that corrective action was successful. In the event of failure after reinspection, information concerning the failure shall be furnished to the cognizant inspection activity and the qualifying activity.

4.6 Inspection of packaging. The sampling and inspection of the preservation, packing, and container marking shall be in accordance with the requirements of MIL-C-55330.

DOD-C-83527

4.7 Methods of examination and test.

4.7.1 Examination of product (see 3.5.1). The connectors, accessories, and piece parts shall be examined to ensure conformance with this specification and the applicable detail drawings not covered by the performance requirements of 3.5. In-process controls of component parts, unrelated to lot sizes of finished connectors, may be utilized in lieu of examination of these components in the finished connectors to assure conformance of these component parts. Examination in a continuing manner shall be performed to assure compliance with the following requirements:

- a. Applicable specification sheet.
- b. Materials.
- c. Design and construction.
- d. Interchangeability.
- e. Marking.
- f. Workmanship.

4.7.2 Contact location (see 3.4.4.3). When measured with gage pins and proper gauges, axial location of contacts from mating face shall meet the requirements of 3.4.4.3.

4.7.3 Mating and separating forces (see 3.5.2). Counterpart plugs and receptacle pairs shall be fully loaded with contacts and mounted in a test fixture simulating the connector angular alignment requirements of DOD-STO-1788 (see figure 13). Each connector pair shall be mated and unmated 10 times. During the eighth, ninth, and tenth cycle the maximum insertion and removal forces during each cycle shall not exceed the level specified in 3.5.2.

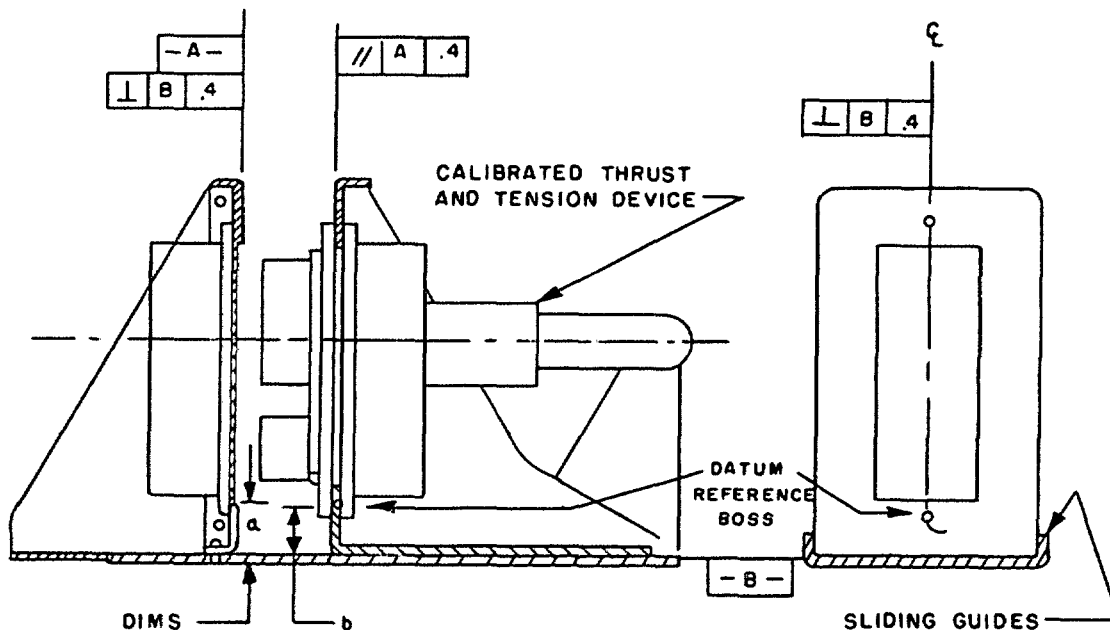

NOTE: Guides shall align plug and receptacle within 1.0 mm max. with dim. "a" > dim. "b".

FIGURE 13. Mating and separating force test arrangement.

DOD-C-83527

4.7.4 Maintenance aging, contact insertion, and removal forces (see 3.5.3). Connectors shall be tested in accordance with method 2002 of MIL-STD-1344. A minimum of 20 percent, but not less than five of the contacts in each connector shall then be removed and reinserted 10 times with the aid of the applicable approved tools, the forces required to do so being measured on the first and last of each of the contact insertion and removal cycles.

4.7.5 Contact retention (see 3.5.4). The contact retention shall be tested as specified in method 2007 of MIL-STD-1344. The following details and exceptions shall apply:

- a. Applied axial load - Preload to 15 newtons maximum. Apply load as specified in table X.
- b. Special requirements - Where the test sequence requires maintenance aging prior to contact retention, the contacts which were subjected to maintenance aging shall also be selected for contact retention.
- c. Axial direction - The applicable forces shall be applied along the longitudinal axial of individual contacts in the direction tending to displace the contacts to the rear.
- d. Only the contacts to be tested need be installed in the connector.
- e. Repeat the test in the opposite axial direction. Unwired contacts or test gage may be used.

TABLE X. Axial load for contact retention test.

Contact size	Axial load newtons
22	55
20	90
16	112
12	135
1 and 5 coax	157
8 twinax	157

4.7.6 Altitude-ambient temperature (see 3.5.5). Wired, mated, assembled connectors shall be subjected to the test specified in method 1011 of MIL-STD-1344. The following details apply:

- a. No wire ends or splices inside the chamber.
- b. Dielectric withstanding voltage test to be performed after return to ambient conditions shall be in accordance with 4.7.13.1.
- c. Insulation resistance test to be performed after return to ambient conditions shall be in accordance with 4.7.12.1.

4.7.7 Temperature cycling (see 3.5.6). Mated connectors shall be subjected to the temperature cycling of MIL-STD-1344, method 1003, test condition A, except that steps 2 and 4 shall be of 2 minutes maximum duration, the temperature of step 1 shall be $-65^{\circ}\text{C} +0$, -5 (-85°F) and the temperature of step 3 shall be $150^{\circ}\text{C} +5$, -0 (302°F).

4.7.8 Insert retention (see 3.5.7). Connectors shall be tested in accordance with method 2010 of MIL-STD-1344. The following details and exceptions shall apply:

- a. Connectors shall be unwired and unmated.
- b. Load force of 200 newtons applied to front, then the rear face of each insert.

DOD-C-83527

4.7.9 Salt spray (corrosion) (see 3.5.8). The wired, assembled plugs and receptacles shall be mated and unmated 50 cycles at a rate of 300 cycles per hour maximum. The mating and unmating shall be accomplished so that the plug and receptacle are completely separated during each cycle. The connectors shall then be subjected to the salt spray test in accordance with method 1001 of MIL-STD-1344. The following details and exceptions apply:

- a. The connectors shall be tested for 452 hours mated followed by 48 hours unmated.
- b. The connectors shall not be mounted but shall be suspended from the top of the chamber using waxed twine or string, glass rods, or glass cord.
- c. Wire ends must be protected to prevent salt migration.

After the salt spray exposure the remaining number of durability cycles specified in 4.7.14 shall be completed.

4.7.10 Contact resistance (see 3.5.9). The contact resistance of mated contacts shall be measured in accordance with MIL-STD-1344, methods 3004 and 3002. Method 3002 applies only to size 22 contacts and shall precede method 3004.

4.7.11 Seal leakage (see 3.5.10). Fully wired and properly mated connector halves shall be held vertically in a fixture. The wire bundles from the connector shall be routed so that a drip loop is created on each side of the connector. The low part of the drip loops shall be lower than the lowest part of the connector. The fixture shall be made to rotate at a speed of from 0.5 to 1.5 rpm. The test fluid shall be allowed to fall from approximately 100 holes 2.5 mm diameter in the bottom of a 150 mm diameter container located no higher than 150 millimeters above the highest point of the connector. The test fluid shall be a water solution containing 5 percent of weight salt and 1 percent by weight liquid detergent and shall be circulated at a rate of approximately 11 liters per minute. The solution shall be at room temperature and the ends of the wires shall not be wetted. The fixture shall be operated for 1 hour after which the connector shall be subjected to the insulation resistance and dielectric withstand voltage tests defined in 4.7.12.1 and 4.7.13.1. The connector shall meet the requirements of 3.5.11 and 3.5.13 beginning within 5 minutes after termination of the fluid exposure of the connector.

4.7.12 Insulation resistance.

4.7.12.1 Insulation resistance at ambient temperature (see 3.5.11). Unmated connectors shall be tested as specified in method 3003 of MIL-STD-1344. The following details and exceptions shall apply; where it is undesirable to install actual contacts in connectors, simulated contacts may be used in performing this test.

4.7.12.2 Insulation resistance at elevated temperature (see 3.5.12). Unmated connectors shall be tested as specified in method 3003 of MIL-STD-1344. Connectors shall be exposed to a temperature of 150°C +5, -0 for 30 minutes. Measurement shall be made while the connectors are still in the chamber at the specified temperature.

4.7.13 Dielectric withstanding voltage (see 3.5.13).

4.7.13.1 Dielectric withstanding voltage (sea level). Unmated connectors shall be tested in accordance with method 3001 of MIL-STD-1344 with the following details and exceptions:

- a. The magnitude of the test voltage shall be 1,500 volts rms, 60 Hz.
- b. Fifty percent of the contacts shall be tested, but not less than six applications made, unless the number of contacts is three or less in which case all must be tested.
- c. For quality conformance testing, simulated contacts may be used in performing this test.

DOD-C-83527

4.7.13.2 Dielectric withstanding voltage (altitude). Mated connectors and unmated connector halves shall be tested in accordance with method 3001 of MIL-STD-1344 with the following details and exceptions:

- a. The magnitude of the test voltage shall be as specified in table XI.
- b. Fifty percent of the contacts shall be tested, but not less than six applications made, unless the number of contacts is three or less in which case all must be tested.
- c. The leads of all test circuits shall be brought out through the walls of the chamber. There shall be no wire splices inside the chamber. The wire ends of all leads shall be unsealed.
- d. The chamber shall be evacuated to each of the specified altitude pressure equivalents listed in table XI.

TABLE XI. Test voltages - 60 Hz rms.

Altitude (KPA)	Mated (volts)	Unmated (volts)
11.6	800	550
4.4	800	350
1.1	800	200

4.7.14 Durability (see 3.5.14). Wired and assembled plugs and receptacles shall be subjected to test method 2016 of MIL-STD-1344. The following details and exceptions shall apply:

- a. 500 cycles of mating unmating (including electrical contact engagement).
- b. Engagement and complete separation shall be similar to that encountered in service, and may be accomplished by machine.

4.7.15 Vibration (see 3.5.15). Wired, mated connectors shall be subjected to the test specified in method 2005 of MIL-STD-1344. The following details and exceptions shall apply:

- a. The test plug connector shall be mounted to a fixture through normal mounting provisions. See figure 14.
- b. The test receptacle connector shall be mounted to a dummy loaded size 8 LRU per figure 15.
- c. With receptacle connector mounted to dummy loaded LRU and plug mounted to test fixture, the assembled LRU shall be secured with hold-down devices specified.
- d. Test curve per figure 16.
- e. The duration of test shall be 4 hours each in all three axes.
- f. All contacts shall be wired in a series circuit and a 100 +10 -0 milliamperes current shall be caused to flow during vibration.

4.7.16 Shock (see 3.5.16). The connectors shall be tested in accordance with method 2004 of MIL-STD-1344. The following details shall apply:

- a. Test condition letter - H (30G, 11 ms, half sine)
- b. Test set-up shall be same as for vibration test - See figures 14 and 15.
- c. All contacts shall be wired in a series circuit and a 100 +10 -0 milliamperes current shall be used.

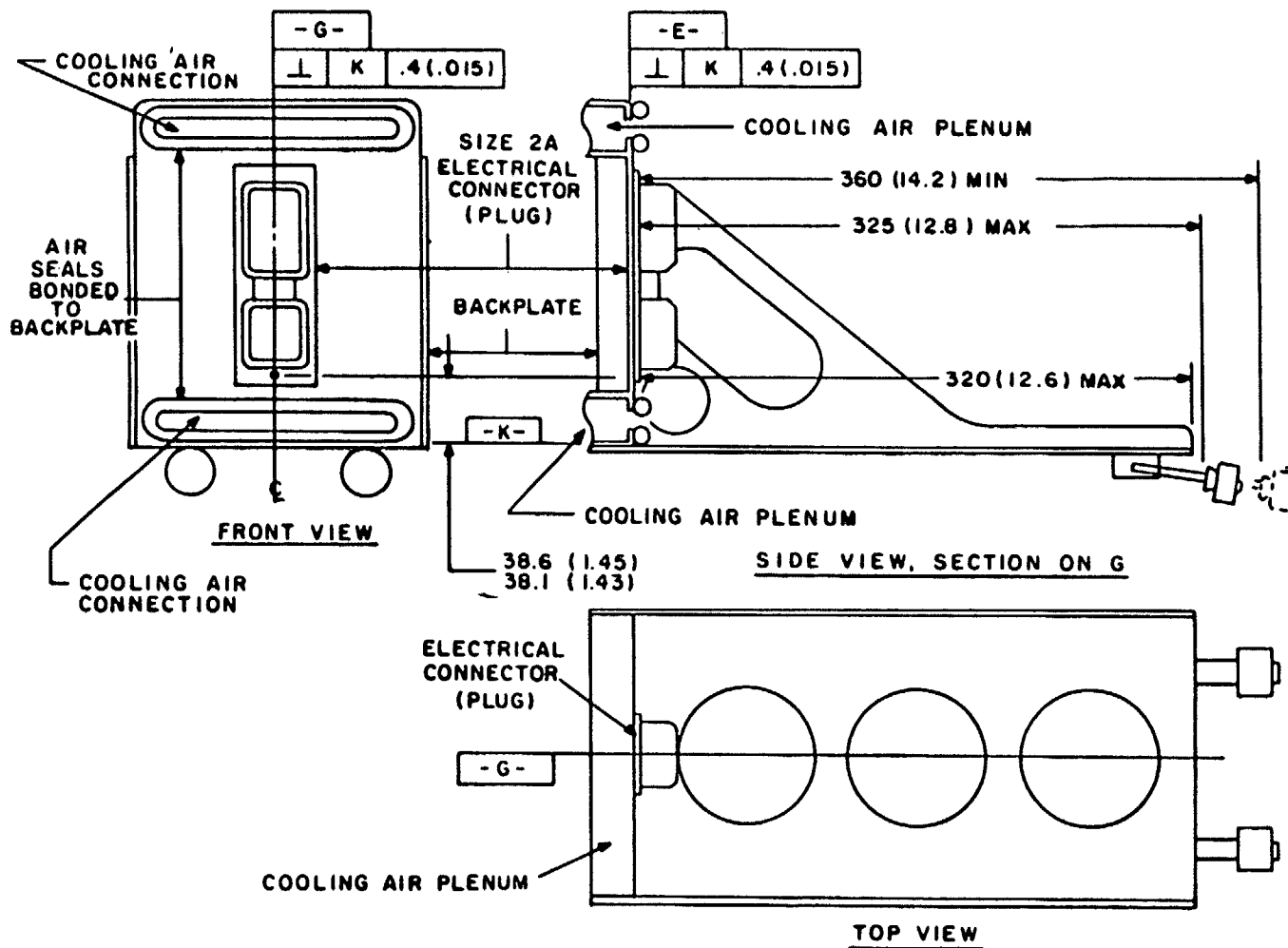

- NOTES:
 1. Dimensions are in millimeters.
 2. Inch equivalents are in parentheses.

FIGURE 14. Structural support design.

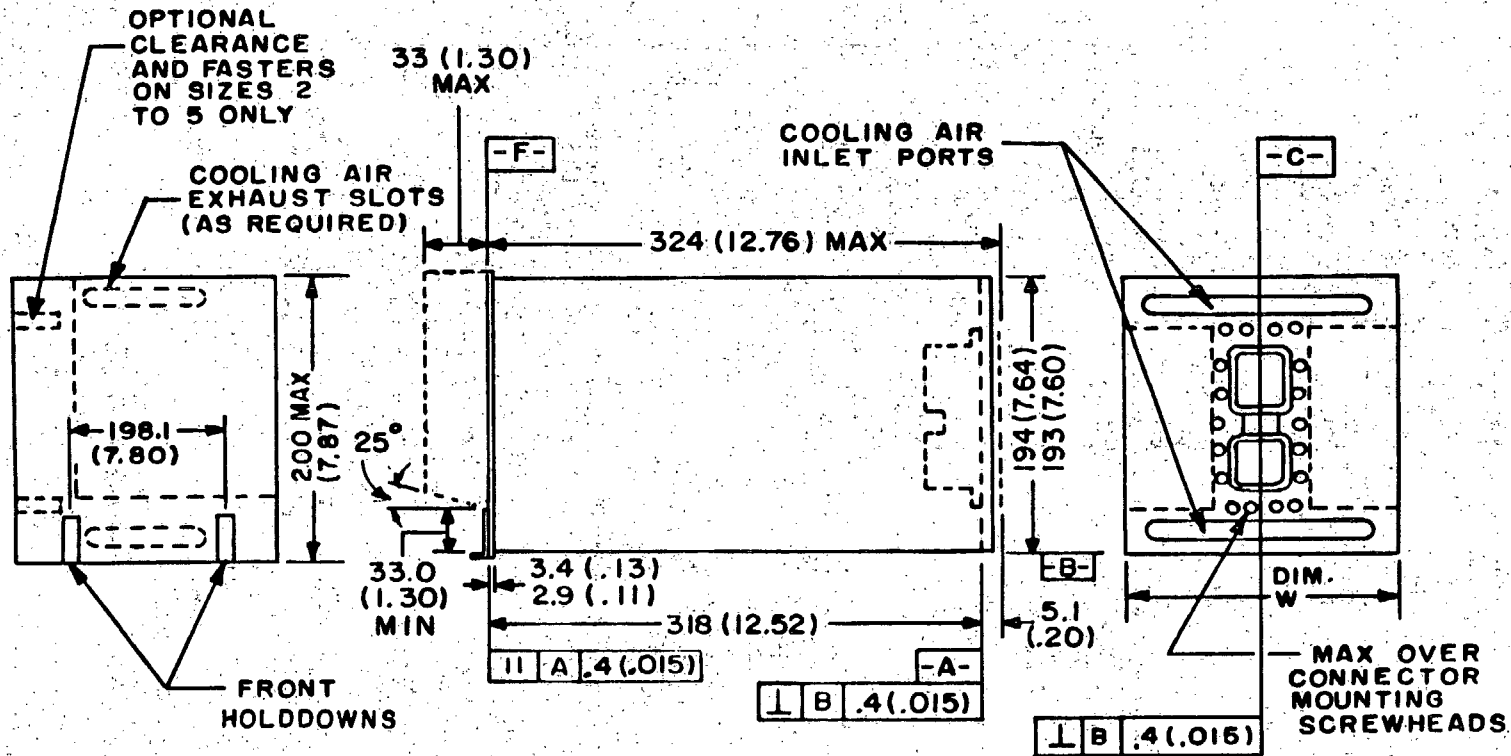

34

DOD-C-83527

NOTES:

1. LRU shall be dummy loaded to 60.0 ±0.5 pounds with center of gravity ±10% of unit center in the vertical and width directions in the longitudinal (front to rear) direction. The center of gravity shall be 30 ±5% from the connector end.
2. Connector location shall be based on datum boss of connector flange.
3. LRU shall be constructed such that dummy load is evenly distributed and the sides properly supported to simulate a rigid body.
4. Dimensions are in millimeters.
5. Inch equivalents are in parentheses.

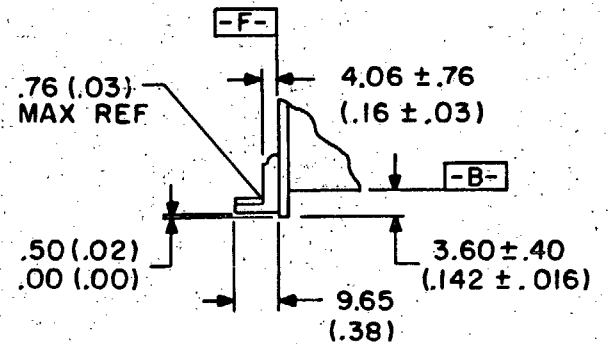

FIGURE 15. Ziz 8 LRU box.

DOD-C-83527

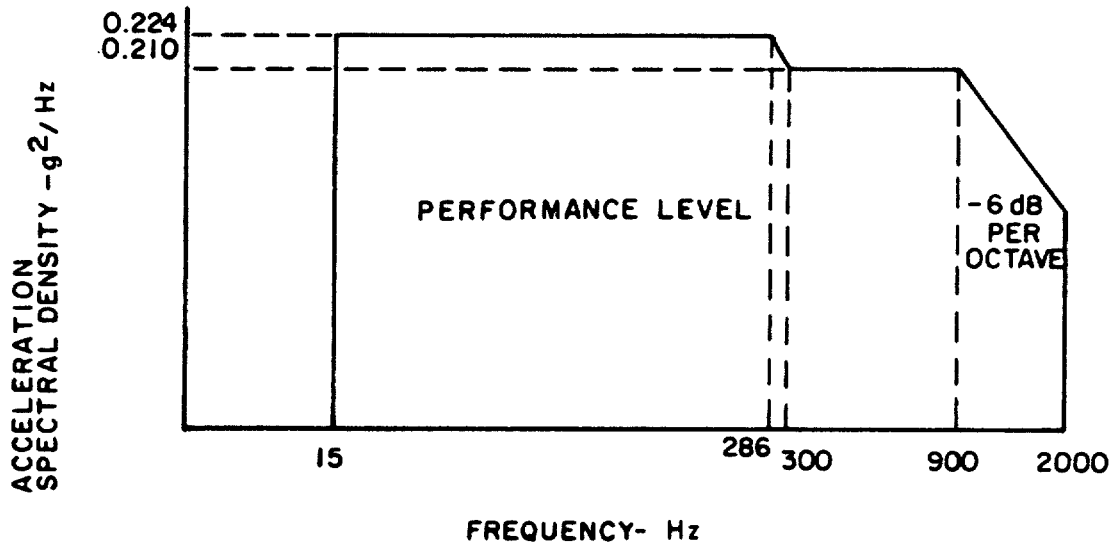

FIGURE 16. Random vibration test curve.

4.7.17 Static load (see 3.5.17). Wired connectors shall be mounted on separate aluminum plates 2.5 millimeters thick. The mate connectors shall support the specified load applied uniformly to the mounting plates in each of the three principal axes, A - mating compression, B - vertical shear, C - sideload shear, in accordance with figure 17. Force shall be applied gradually at a rate approximately 100 N/sec and the final specified value shall be maintained for 1 minute.

4.7.18 Shell-to-shell conductivity (see 3.5.18). Each shell cavity of mated connector pairs shall be subjected to the test specified in method 3007 of MIL-STD-1344. Measuring points shall be rear surfaces of mounting flange.

4.7.19 Humidity (see 3.5.19). Wired, mated connectors shall be subjected to the humidity test specified in method 1002 of MIL-STD-1344. The following details and exceptions shall apply:

- a. Type I.
- b. Test condition letter - A.
- c. The mated connectors shall be mounted in a horizontal position.

DOD-C-83527

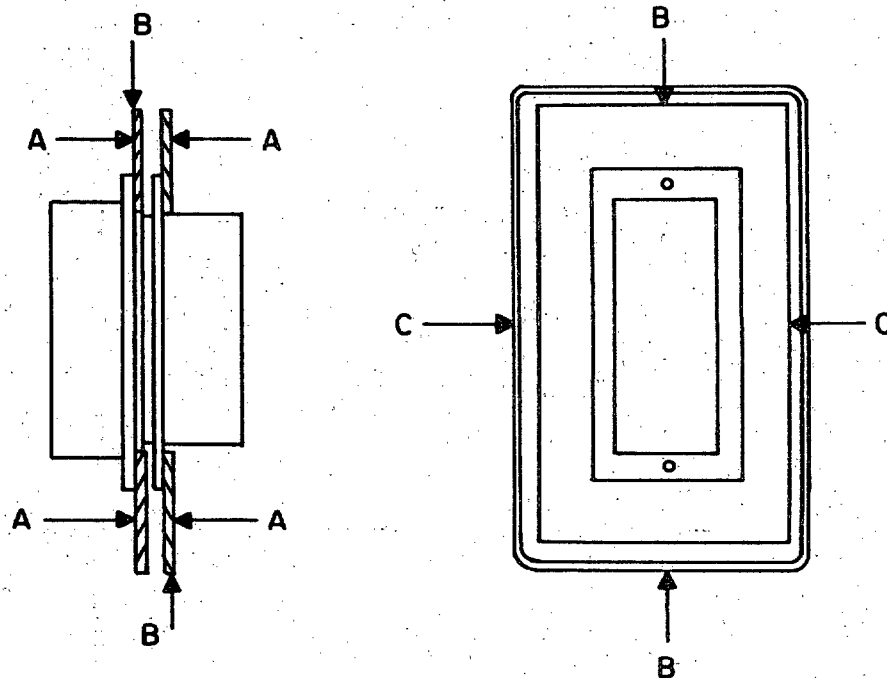

FIGURE 17. Static load test arrangement.

4.7.20 EMI Shielding (see 3.5.20).

4.7.20.1 Test sample. A size 2 plug and receptacle shell shall be used for this test. Shells shall be modified by removing all excess metals except the housing and flange around insert cavity B (see figure 18). Peripheral and EMI seals shall remain on the plug shell.

4.7.20.2 Sample preparation. The inserts may be removed from the connectors under test or the contacts removed and a hole drilled through the inserts to accommodate a center conductor of suitable geometry to provide a good 50-ohm impedance match with the inside diameter of the mated connector shells.

Tapered transition may be used to provide a means of changing diameters without introducing significant discontinuities in the line. The maximum VSWR in the inner coaxial line shall be 1.5:1. The outer shell of the test fixture shall be so constructed as to provide a good 50-ohm impedance match with the outside shape of the mated connector shells and the transition section. The maximum VSWR of the outer coaxial line shall be 1.5:1. Four (4) nylon screws and nuts (size 4-40) shall be used to clamp the mating connector shells together to simulate normal LRU hold down force.

DOD-C-83527

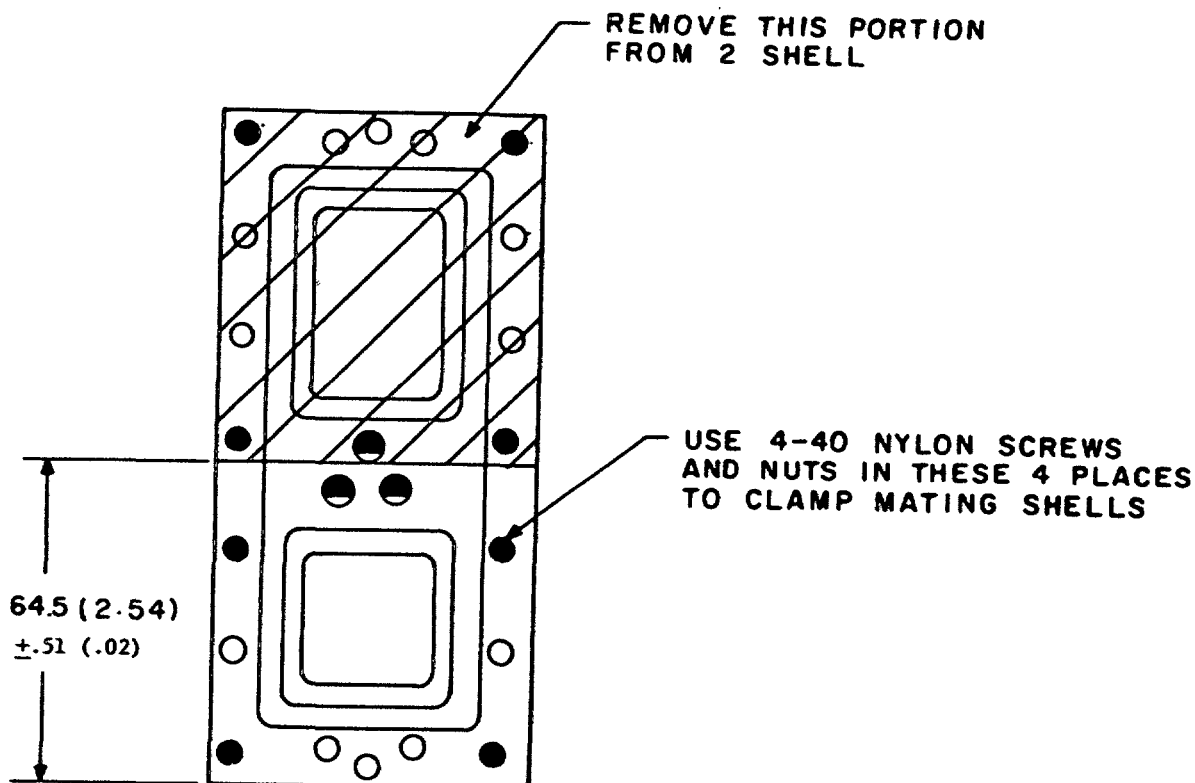

FIGURE 18. Connector preparation - EMI test.

4.7.20.3 Test procedure. The EMI shielding effectiveness of mated connectors shall be measured in a triaxial radio frequency leakage fixture as shown on figure 19. The EMI leakage from the conductor inside the connector in the same inner coaxial line into the outer coaxial line shall be measured at the frequencies specified in table V within a frequency accuracy of ± 5 percent. The level of detected signal power shall be indicated by tunable radio frequency field intensity meter isolated from the test circuit by a 3 to 10 dB pad. Care shall be taken to ensure that the signal is a result of EMI leakage from within the mated connector and not due to a faulty termination inside the fixture. All terminations inside the fixture, whether to the transition section or between internal conductors, shall have a leakage at least 10 dB less than the test requirements. The signal source shall be set to the desired frequency. The signal shall be fed through a 3 to 10 dB isolation pad to a parallel circuit consisting of a coaxial switch (DPDT) so connected that the signal can be manually or electronically fed alternately to the fixture and to a variable 100 dB reference attenuator. The attenuator shall be adjustable in 1 dB steps and calibrated to ± 3 dB.

A sliding circumferential short shall be positioned behind the connector on the signal input end of the fixture to provide for turning the outer coaxial line for maximum output at each test frequency. The allowable travel of this short shall be greater than $1/2$ wave length at the lowest test frequency of 1.5 meters minimum for 100 MHz. The inner coaxial line shall be terminated in a fixed 50-ohm load impedance behind the connector at the output end of the fixture.

The connectors used to couple together the various elements of the test system shall be of a low-leakage type which have a nominal impedance of 50-ohms, a VSWR of less than 1.5:1 and a minimum leakage attenuation of 100 dB. The output impedance of the signal source and the input impedance of the detector shall be nominally 50 ohms with a maximum VSWR of 1.5:1. The input and output VSWR of the standard attenuator shall be less than 1.5:1 in the 20 to 100 dB range.

The relative signal level in the variable attenuator shall be equaled to the signal level through the leakage fixture by adjusting the attenuator. The signal loss in the fixture can then be read from the setting on the variable attenuator.

DOD-C-83527

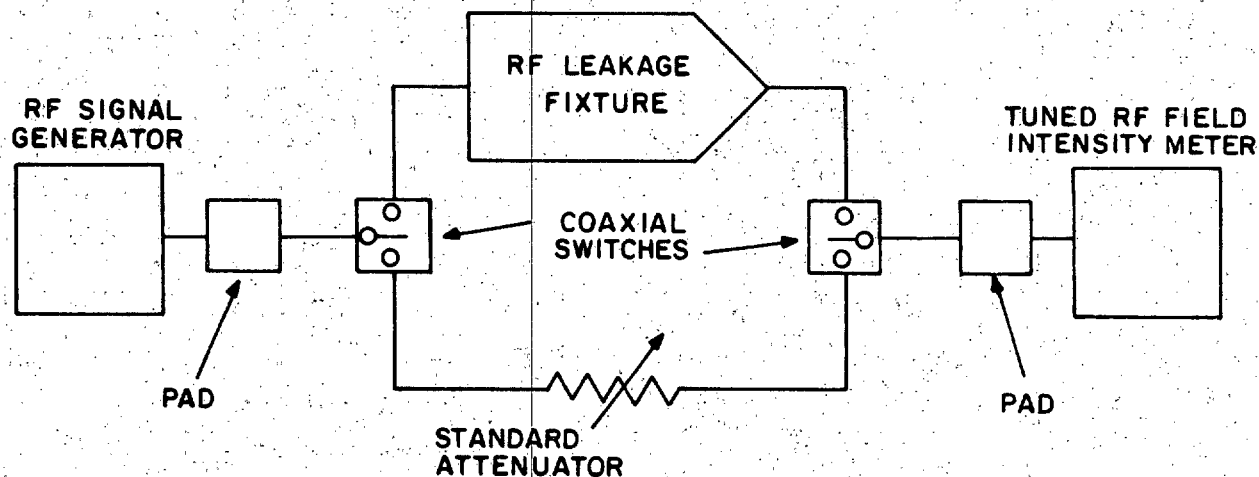

SCHEMATIC TEST SYSTEM

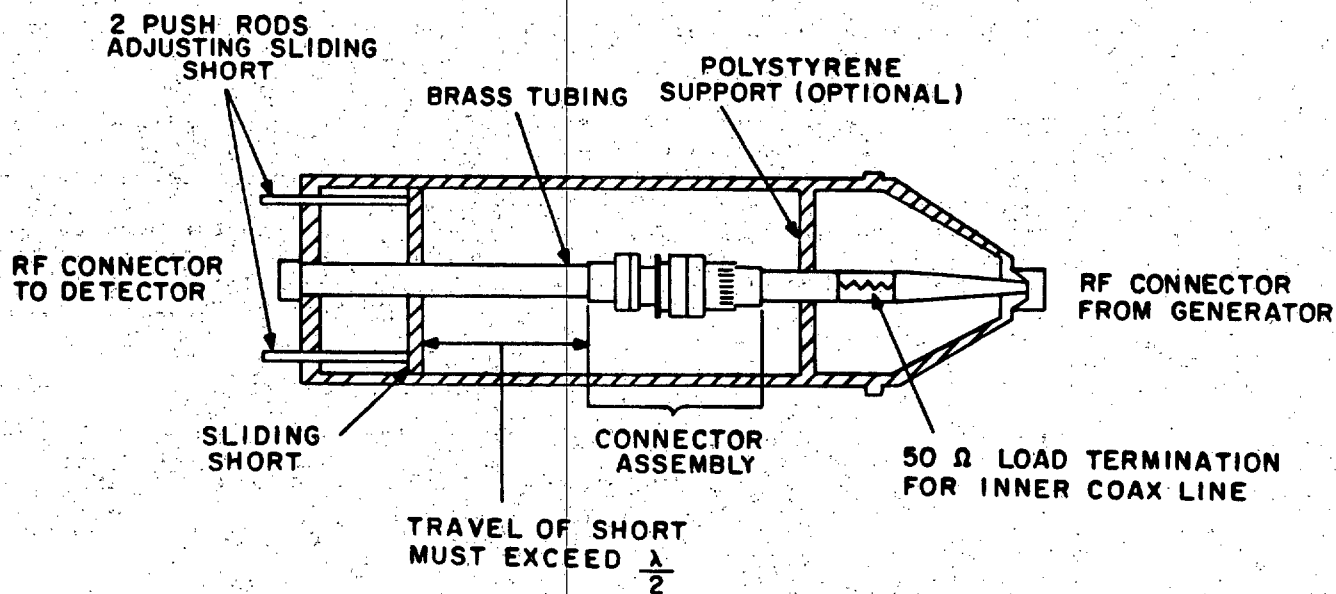

FIGURE 19. EMI test set-up.

DOD-C-83527

4.7.21 Ozone exposure (see 3.5.21). The unmated connectors shall be subjected to the test specified in method 1007 of MIL-STD-1344. At the end of the specified period, the samples shall be examined for signs of ozone deterioration as specified.

4.7.22 Fluid immersion (see 3.5.22). Connector samples shall be subjected to the test specified in method 1016 of MIL-STD-1344. Following the fluid immersion cycles, the connectors shall be tested for mating and separating forces as specified in 4.7.3 and dielectric withstanding voltage at sea level as specified in 4.7.13.1 within 3 hours. The following details apply:

- a. Connectors shall be wired and unmated.
- b. One connector shall be immersed in each fluid.
- c. Fluid (L) shall be at a temperature of 150°C.

4.7.23 Retention system fluid immersion (see 3.5.22). Connectors shall be subjected to the test specified in method 1016 of MIL-STD-1344. The following details and exceptions shall apply:

- a. Connectors shall be unmated, with no contacts.
- b. Immersion time shall be 2 hours.
- c. One connector shall be immersed in each fluid.
- d. Fluid (L) shall be at a temperature of 150°C.

After removal from the fluid, excess fluid shall drain from the connector for 4 hours and contacts installed. The connectors shall then be subjected to the contact retention (4.7.5) and insert retention (4.7.8) tests.

4.7.24 Contact walk-out (see 3.5.24). Two contacts in each plug and receptacle shall be tested. The contacts shall be crimped to stranded steel cable of an appropriate size and installed in the connector. The unmated connector shall be mounted in a test fixture as shown on figure 20. A 1.4 kilogram load shall be applied to the cable. One 360° rotation of the fixture with the connector mounted shall constitute one cycle. The connector shall be subjected to 100 cycles at a rate of 10 to 20 cycles per minute. Contact cavities used in this test shall be excluded from further testing.

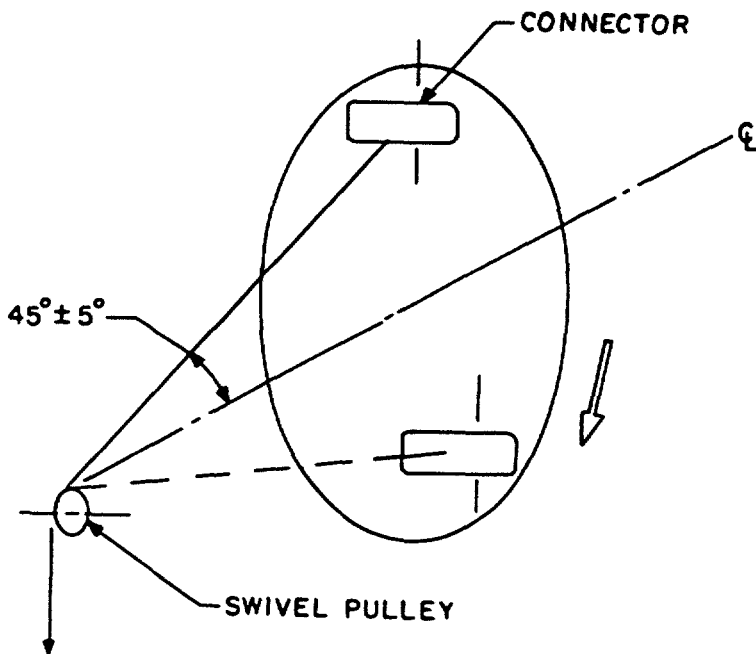

FIGURE 20. Contact walkout test arrangement.

DOD-C-83527

4.7.25 Altitude immersion (see 3.5.23). Mated connector shall be tested in accordance with method 1004 of MIL-STD-1344. The following details shall apply:

- a. All wire ends shall be located within the chamber and exposed to the chamber atmosphere but not submerged or sealed.
- b. At the end of the third cycle while the connectors are still submerged in the solution, the insulation resistance at ambient temperature, shall be measured as specified in 4.7.21.1 and the dielectric withstanding voltage test shall be performed as specified in 4.7.13.1.

4.7.26 Installing and removal tool abuse (see 3.5.25). Tools used shall be in accordance with MIL-I-81969. Five contact cavities in each insert shall be subjected to each of the tests in 4.7.26.1 through 4.7.26.4. Different contact cavities shall be used for each test. Should a tool become damaged during any of the testing it shall be replaced. Failure of a tool shall not constitute a test failure. Contact cavities used in this test shall not be subjected to further testing.

4.7.26.1 Removal tool rotation. The applicable contact removal tool shall be inserted as if to remove a contact and an axial load of 13 newtons shall be applied. With the force applied, the tool shall be rotated 180° maximum and then removed, also removing the contact. The contact shall be reinserted. These steps shall be repeated three times on each of the five contacts selected.

4.7.26.2 Installing tool rotation. The contact shall first be removed. With the applicable contact installing tool, the contact shall be reinstalled and an axial load of 13 newtons applied to the tool. With the force applied, the tool shall be rotated 180° maximum and then removed. These steps shall be repeated three times on each of the five contacts selected.

4.7.26.3 Installing tool thrust. The contact shall first be removed. With the applicable contact installing tool, the contact shall be reinstalled and an axial load of 45 newtons applied to the tool. These steps shall be performed only once on each of the five contacts selected. A new tool shall be used for each contact.

4.7.26.4 Removal tool thrust. The applicable contact removal tool shall be inserted as if to remove the contact and an axial load of 45 newtons shall be applied to the tool. The tool shall then be removed, also removing the contact. These steps shall be performed only once on each of the five contacts selected. A new tool shall be used for each contact.

4.7.27 Contact stability (see 3.5.26). The unmated connectors shall have 10 percent (but not less than one) of their contacts subjected to this test. Gages conforming dimensionally to figure 21 shall be used. The connector shall be held in a holding device. A moment shall be applied to the exposed rod as shown on figure 22. The rate of load application shall not exceed .5 millimeters per second. The total gage tip displacement shall be measured as shown on figure 22. Contact cavities used in this test shall be excluded from further testing.

4.7.28 Temperature life with contact loading (see 3.5.27). Connectors with removable contacts shall have one mating pair of contacts removed and replaced with contacts crimped to steel cable or steel-cored copper wire (copperweld) of an appropriate size. The axial location of these contacts shall be measured with a load of 9 newtons approximately applied to seat the contact back against the retention device. The connection shall then be mounted in a fixture as shown on figure 23. A weight equal to 50 percent of the axial load specified in table X for the applicable contact size shall be suspended freely from each steel wire. A current of 100 +10 -0 milliamperes, supplied from a 10.0 V dc maximum power source shall be applied to the test contacts and a suitable instrument shall be used to monitor the circuit for discontinuities in excess of 1 microsecond. The connector, mounted as shown on figure 23 shall then be exposed to 150 +5°C -0 for a period of 1,000 hours. After the connectors return to ambient temperature, they shall be unmated and the contact locations remeasured with approximately 9 newtons axial load applied to seat the contact back against the retention device.

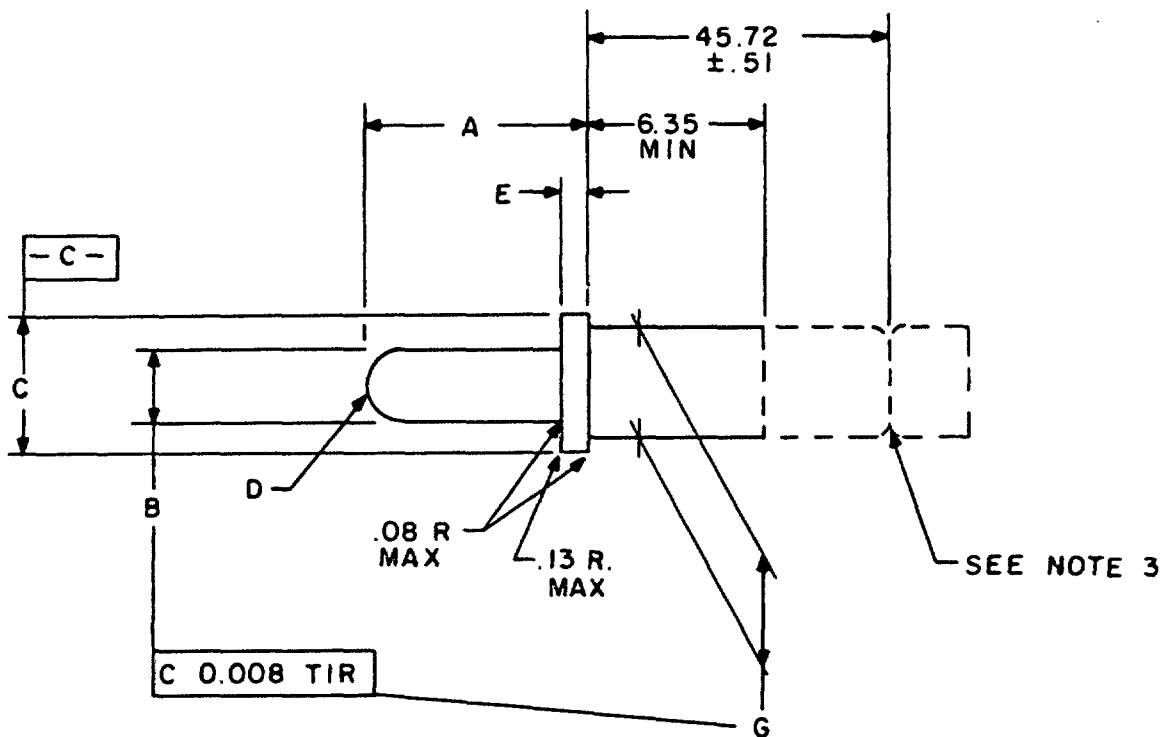

CONTACT SIZE	A +0.013 -0.000	B DIA +0.005 -0.000	C DIA +0.005 -0.000	D RAD	E +0.000 -0.005	G DIA +0.000 -0.005
22	10.18	1.50	1.73	0.10/0.00	.84	1.27
20	15.67	.99	2.08	Spherical	.84	1.73
16	19.08	1.56	3.30	Spherical	.84	2.62
12	19.08	2.36	4.72	Spherical	.84	3.84

MM	INCHES	MM	INCHES
.000	0.00	2.08	0.082
.005	0.0002	2.36	0.093
.013	0.0005	2.62	0.103
.84	0.033	3.30	0.130
.99	0.039	3.84	0.151
1.27	0.050	4.72	0.186
1.50	0.059	10.18	0.401
1.56	0.061	15.67	0.617
1.73	0.068	19.08	0.751

NOTES:

1. Material: Hardened tool steel.
2. Finish: 32 microinches polished.
3. Design of rear extension is optional, but must have a groove provided as indicated.
4. Dimensions are in millimeters.
5. Inch equivalents are given for general information only.

FIGURE 21. Gage configuration.

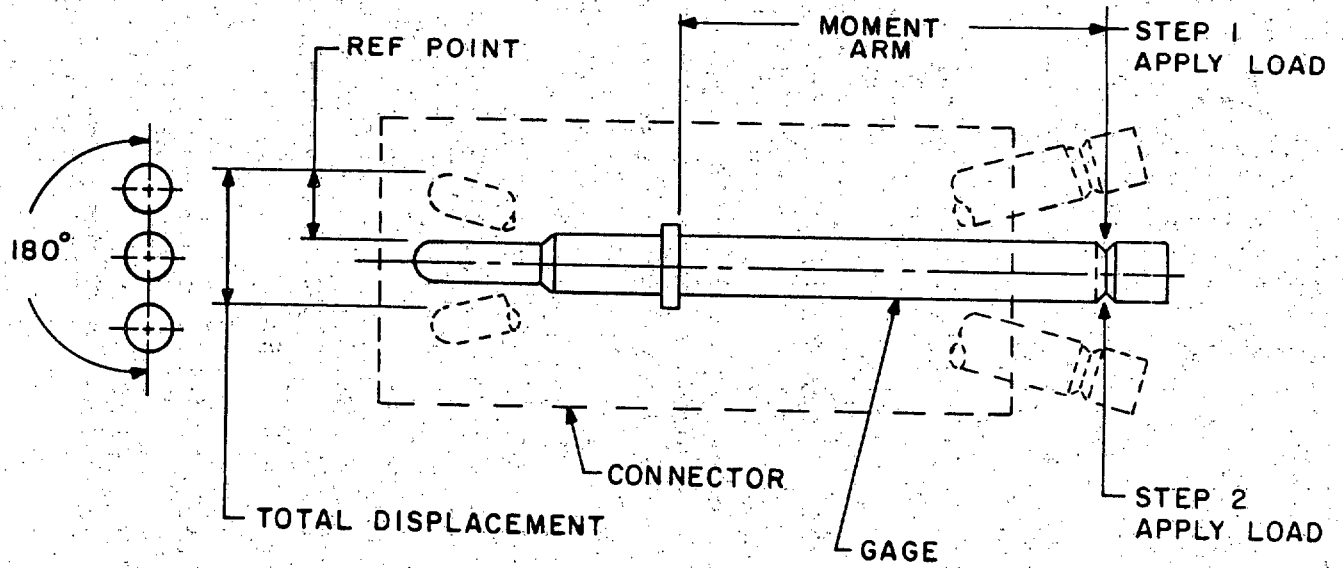

CONTACT SIZE	MOMENT NEWTON METER
22	0.1 (0.004)
20	0.2 (0.008)
16	0.25 (0.010)
12	0.25 (0.010)

STEP 1 - APPLY LOAD TO DETERMINE REFERENCE POINT
 STEP 2 - APPLY LOAD IN OPPOSITE DIRECTION AND MEASURE TOTAL DISPLACEMENT

NOTE:

1. Inch equivalents are in parentheses.

FIGURE 22. Contact stability test arrangement.

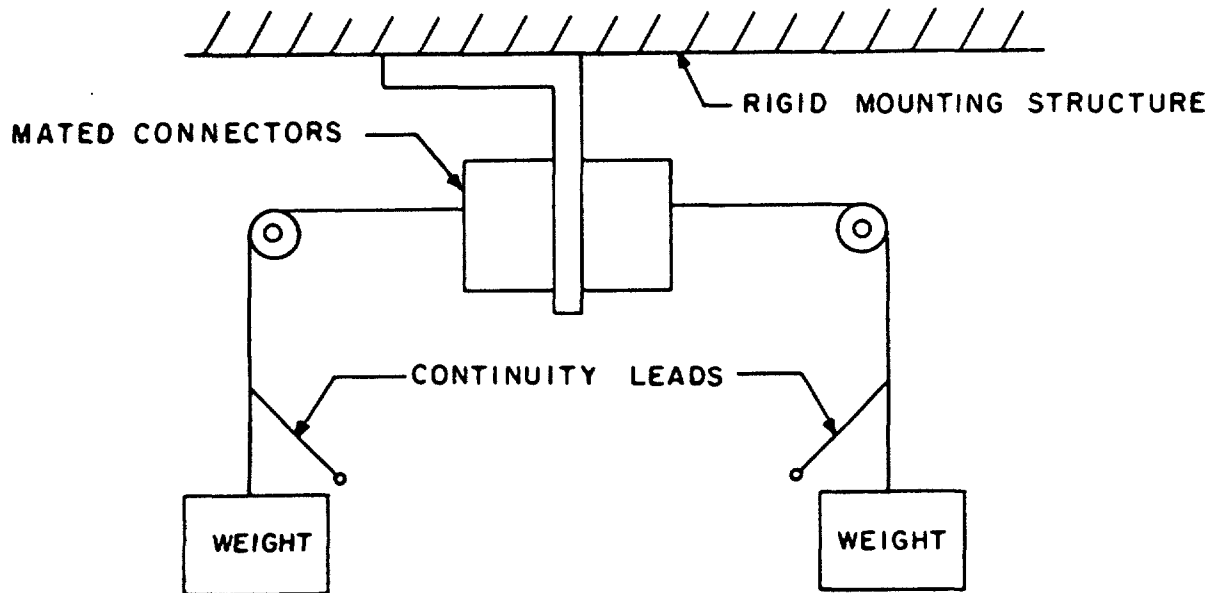

FIGURE 23. Contact loading arrangement for temperature life test.

4.7.29 Nonmagnetic materials (see 3.3.2). Connectors shall be tested as specified in method 3006 of MIL-STD-1344.

4.8 Post test examination. The tested connectors and contacts shall be examined to determine the effects of previous testing. Any evidence of cracking, loosening of parts, carbon tracking, excess wear, or missing parts shall be recorded.

5. PACKAGING

5.1 Packaging requirements. The requirements for packaging shall be in accordance with MIL-C-55330.

6. NOTES

6.1 Intended use. The connectors are intended for use in conjunction with military standard rack or tray mounted avionics units to provide for mechanically secure attachment, and quick removal and replacement of the avionics unit. They withstand high vibration, and are environmentally resistant and shielded against electromagnetic interference when engaged.

6.1.1 Application guidance. The application of the connector is described in DOD-STD-1788. An individual line replaceable unit (LRU) cannot have multiple connectors, but each connector shell variant can accommodate multiple inserts. Inserts are limited to two sizes, but each size of insert can accommodate multiple pin/socket, and coaxial contact configurations.

DOD-C-83527

6.2 Ordering data. Acquisition documents should specify the following:

- a. Title, number, and date of this specification.
- b. Title, number, and date of the applicable specification sheet and the complete part number.
- c. Whether contacts, sealing plugs, and tools are included (see 3.4.1, 3.4.2, 3.4.3.6, and 3.4.4).

6.3 Qualification. With respect to products requiring qualifications, awards will be made only for products which are at the time set for opening of bids, qualified for inclusion in applicable qualified products list (QPL) whether or not such products have actually been so listed by that date. The attention of the contractors is called to this requirement, and manufacturers are urged to arrange to have products that they propose to offer to the Federal Government tested for qualification in order that they may be eligible to be awarded contracts or orders for the products covered by this specification. For all series the activity responsible for the qualified products list is the Air Force 2750th Air Base Wing, Electronic Support Division (2750th ABW/ES), Gentile AFS, Dayton, Ohio 45444; however, information pertaining to qualification of products may be obtained from the Defense Electronics Supply Center (DESC-E), Dayton, Ohio 45444.

6.3.1 Evaluating activity. The activity responsible for evaluating the qualification test reports if other than DESC-E is listed on the applicable specification sheets (see 3.1). The qualifying activity (DESC-E) will notify the prospective contractor as to where the test reports are to be forwarded. The evaluating activity is responsible for notifying the prospective contractor that the test report is acceptable.

6.3.2 Copies of "Provisions Governing Qualification SD-6". Copies of "Provisions Governing Qualification SD-6" may be obtained upon application to Commanding Officer, Naval Publications and Forms Center, 5801 Tabor Avenue, Philadelphia, Pennsylvania 19120.

6.4 Definition.

6.4.1 Rated temperature. Rated temperature is the maximum value of the temperature range and also the maximum hot spot temperature of the connector.

6.4.2 EMI backshell An EMI backshell is a device which is designed to control electromagnetic interference caused by the radiation of signals at interconnecting areas.

Custodians:
 Army - CR
 Navy - AS
 Air Force - 85

Preparing activity:
 Air Force - 85

Review activities:
 Navy - EC
 Air Force - 11, 17, 99
 DLA - ES

(Project 5935-3413)

Agent:
 DLA - ES

