

INCH-POUND

MIL-C-83421/4A
 7 June 1991
 SUPERSEDING
 MIL-C-83421/4
 25 July 1989

MILITARY SPECIFICATION SHEET

(A) CAPACITORS, FIXED, METALLIZED PLASTIC FILM, DIELECTRIC,
 (DC, AC, OR DC AND AC), HERMETICALLY SEALED IN METAL CASES,
 HIGH RELIABILITY (INSULATED),
 STYLES CRS11, CRS12, AND CRS13

This specification is approved for use by all Departments and Agencies of the Department of Defense.

The requirements for acquiring the product described herein shall consist of this specification sheet and the issue of the following specification listed in that issue of the Department of Defense Index of Specifications and Standards (DODISS) specified in the solicitation: MIL-C-83421.

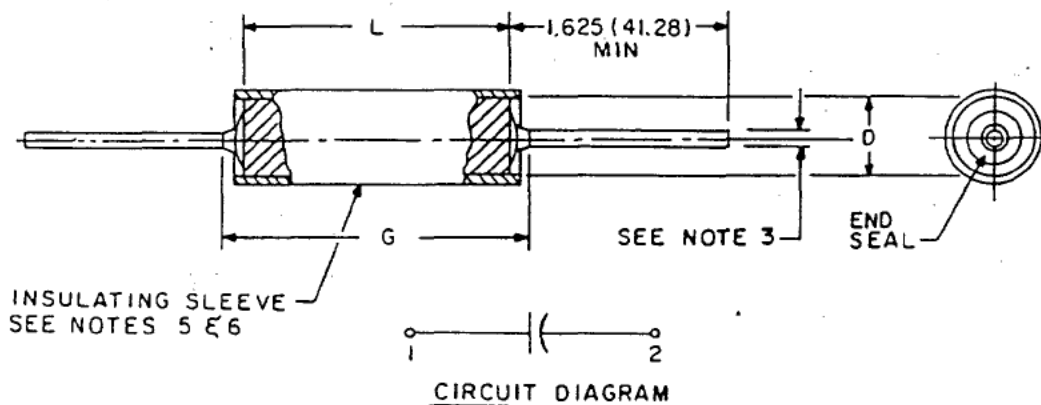

NOTES:

1. Dimensions are in inches.
2. Metric equivalents are in parentheses and are general information only.
3. Number 18 AWG wire .040 inch ± 0.02 (1.02 ± 0.05 mm).
4. See table I for additional dimensions.
5. Insulating sleeve shall extend beyond the capacitor body. Insulating sleeve thickness shall not exceed .005 inch (0.13 mm).
6. Plastic insulating sleeve shall be transparent; marking shall be applied to the capacitor case.

FIGURE 1. Capacitor configuration.

(A) denotes changes

MIL-C-83421/4A

(A) TABLE I. Electrical characteristics, dimensions, and dash numbers - Continued.

Capacitance value (nom) (in μF)	Dimensions 1/		Dash number	ESR 20 kHz 100 kHz (ohm s maximum)	AC rating maximum 400 Hz	Ripple current 20 kHz to 100 kHz (amperes rms) 2/										
	L (in inches)	D (mm in parentheses) G (max)				maximum case temperature ($^{\circ}\text{C}$)										
						25	35	45	55	65	75	85				
						Capacitance tolerance value (in %) ± 0.25 ± 0.5 ± 1.0 ± 2.0 ± 5.0 ± 10.0 maximum)										
						CRH13 - 400 VOLTS (dc rating)										
0.001	0.562(14.27)	0.235(5.97)	0.762(19.35)	3103	3104	3105	3106	3107	3108	0.49	0.46	0.42	0.39	0.35	0.30	0.25
0.0012	"	"	"	3109	3110	3111	3112	3113	3114	0.50	0.47	0.44	0.40	0.36	0.31	0.25
0.0015	"	"	"	3115	3116	3117	3118	3119	3120	0.52	0.48	0.45	0.41	0.37	0.32	0.26
0.0018	"	"	"	3121	3122	3123	3124	3125	3126	0.53	0.50	0.46	0.42	0.38	0.33	0.27
0.002	"	"	"	3127	3128	3129	3130	3131	3132	0.57	0.53	0.49	0.45	0.40	0.35	0.28
0.0022	"	"	"	3133	3134	3135	3136	3137	3138	0.59	0.55	0.51	0.46	0.41	0.36	0.29
0.0027	"	"	"	3139	3140	3141	3142	3143	3144	0.61	0.57	0.53	0.48	0.43	0.37	0.30
0.0033	"	"	"	3145	3146	3147	3148	3149	3150	0.63	0.59	0.55	0.50	0.45	0.39	0.32
0.0039	"	"	"	3151	3152	3153	3154	3155	3156	0.66	0.62	0.57	0.52	0.47	0.41	0.33
0.0047	"	"	"	3157	3158	3159	3160	3161	3162	0.69	0.65	0.60	0.55	0.49	0.42	0.35
0.0056	0.687(17.45)	"	0.887(22.53)	3163	3164	3165	3166	3167	3168	0.80	0.74	0.69	0.63	0.56	0.49	0.40
0.0068	"	"	"	3169	3170	3171	3172	3173	3174	0.90	0.84	0.78	0.71	0.64	0.55	0.45
0.0082	"	"	"	3175	3176	3177	3178	3179	3180	0.97	0.91	0.84	0.77	0.69	0.60	0.49
0.01	"	"	"	3181	3182	3183	3184	3185	3186	1.05	0.98	0.91	0.83	0.74	0.64	0.52
0.012	"	"	"	3187	3188	3189	3190	3191	3192	1.19	1.12	1.03	0.94	0.84	0.73	0.60
0.015	0.813(20.65)	0.312(7.92)	1.013(25.73)	3193	3194	3195	3196	3197	3198	1.95	1.82	1.69	1.54	1.38	1.19	0.97
0.018	"	"	"	3199	3200	3201	3202	3203	3204	2.04	1.90	1.76	1.61	1.44	1.25	1.02
0.02	"	"	"	3205	3206	3207	3208	3209	3210	2.14	2.00	1.85	1.69	1.51	1.31	1.07
0.022	"	"	"	3211	3212	3213	3214	3215	3216	2.25	2.11	1.95	1.78	1.59	1.38	1.13
0.027	"	"	"	3217	3218	3219	3220	3221	3222	2.32	2.17	2.01	1.83	1.64	1.42	1.15
0.033	0.875(22.23)	0.400(10.16)	1.075(27.31)	3223	3224	3225	3226	3227	3228	2.85	2.66	2.47	2.25	2.01	1.74	1.42
0.039	"	"	"	3229	3230	3231	3232	3233	3234	3.04	2.85	2.64	2.41	2.15	1.86	1.52
0.047	"	"	"	3235	3236	3237	3238	3239	3240	3.29	3.08	2.88	2.65	2.40	2.12	1.64

See footnotes at end of table.

MIL-C-83421/4A

REQUIREMENTS:

Parts supplied to this specification will be the lowest failure rate on the qualified products list (QPL) of MIL-C-83421/2 and shall have passed subgroups 1 and 2 of group A inspection in MIL-C-83421. All parts shall be permanently serialized on the case prior to group A inspection as specified herein.

Reliability assurance program:

- a. Prior to granting of qualification approval, a baseline document in accordance with appendix A of MIL-C-87217 shall be prepared by the manufacturer and approved by the qualifying activity.
- b. Traceability of materials in accordance with MIL-STD-790 is required.
- c. An inspection lot shall consist of capacitors of the same style, voltage rating, design, and nominal capacitance rating produced in the same case size. Manufacture of all parts in the lot shall have been started, processed, assembled, and tested as a group. Lot identity shall be maintained throughout the manufacturing cycle.

Design and configuration: See figure 1 and table I.

Leads: In accordance with MIL-C-83421/2.

Capacitance value: See table I.

DC rated voltage: 100 V dc, 200 V dc, and 400 V dc.

Operating temperature: -55°C to +85°C.

AC current ratings: See table I.

DC burn-in: 140 percent of dc rated voltage shall be applied for 48 hours minimum at 85°C, +4°C, -0°C.

AC burn-in: Rated ac current at 40 kHz for 48 hours minimum at 85°C, +4°C, -0°C.

Thermal shock: Method 107 of MIL-STD-202, condition B, 10 cycles with the following exception: -65°C to +85°C.

Seal: Method 112 of MIL-STD-202, test condition C, procedure IIIa, followed by test condition D at 85°C. Leakage rate sensitivity to 10^{-6} atm cm^3/s .

MIL-C-83421/4A

Dielectric withstanding voltage: Method 301 of MIL-STD-202, terminal to terminal.

AC: 100 Hz square wave, peak-to-peak voltage, three times dc rated voltage for 60 to 90 seconds, not to exceed 800 Vp/p (see figure 2).

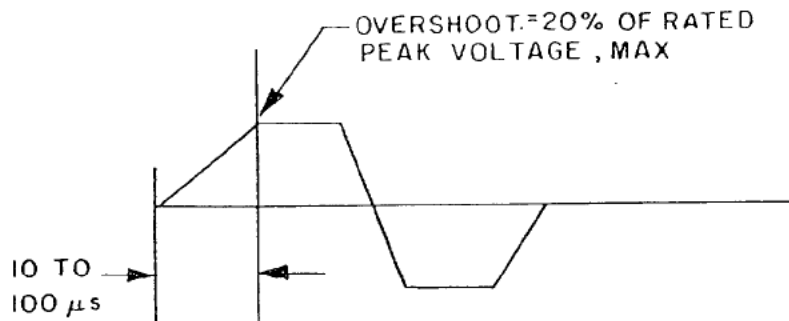

FIGURE 2. Waveform characteristics.

DC: 200 percent of dc rated voltage for 60 seconds minimum.

Insulation resistance: Method 302 of MIL-STD-202. Charge to rated voltage, for 5 minutes maximum; however for capacitance values greater than 1.0 μF , an additional one minute per μF is permitted.

Capacitance: Method 305 of MIL-STD-202. The following details shall apply:

- a. Test frequency: 1,000 Hz \pm 100 Hz.
- b. Limit of accuracy: \pm 0.05 percent.

Dissipation factor: The dissipation factor shall be measured at 1,000 Hz \pm 100 Hz for capacitors having a nominal capacitance of one microfarad or less and 100 Hz \pm 10 Hz for capacitors having a nominal capacitance greater than one microfarad. The limit shall be .07 percent maximum.

Equivalent series resistance: In accordance with MIL-C-83421. See table I for limits.

Radiographic inspection: In accordance with appendix B of MIL-C-87217.

Random vibration: MIL-STD-202, method 214. The following details shall apply:

- a. Mounting: Rigidly mounted by the body to the vibration-test apparatus; terminals shall be secured 0.500 \pm 0.125 inch from the case.
- b. Electrical load conditions: During the test, a dc potential equal to 50 percent of rated dc voltage shall be applied between the terminals of the capacitor.
- c. Test condition: II, letter K.
- d. Duration: 15 minutes in each of two mutually perpendicular directions, one parallel and the other perpendicular to the cylindrical axis.
- e. Measurements: In accordance with MIL-C-83421.

MIL-C-83421/4A

Quality conformance inspection: Group A inspection in table II replaces the one shown in MIL-C-83421.

TABLE II. Group A inspection.

Inspection	Requirement paragraph	Test method paragraph	Number of sample units to be inspected	Number of defectives permitted		
<u>Subgroup 1</u> 1/						
DC burn-in	3.6	4.7.2	Not applicable (100 percent inspection)			
AC burn-in	3.6	4.7.2				
(A) Thermal shock	3.8	4.7.4				
Seal	3.9	4.7.5				
Dielectric withstanding voltage	3.10	4.7.6				
Insulation resistance	3.11	4.7.7				
Capacitance	3.12	4.7.8				
Dissipation factor	3.13	4.7.9				
Equivalent series resistance	3.32	4.8				
Radiographic inspection 2/	3/	3/				
<u>Subgroup 2</u> 4/						
Solderability	3.19	4.7.15			6	0
Random vibration	5/	5/				
<u>Subgroup 3</u>						
Visual and mechanical inspection:						
Physical dimensions	3.1	4.7.1	5	0		
External Marking Workmanship	3.4, 3.5 3.31 3.32	4.7.1 4.7.1 4.7.1	13	0		

- 1/ Percent defective allowable is five percent, except ten percent for radiographic inspection and ten percent for seal test.
- 2/ This test can be done in any sequence within subgroup 1.
- 3/ Requirement and test method paragraphs in accordance with MIL-C-87217.
- 4/ Parts may not be shipped.
- 5/ Requirement and test method paragraphs are as specified herein.

MIL-C-83421/4A

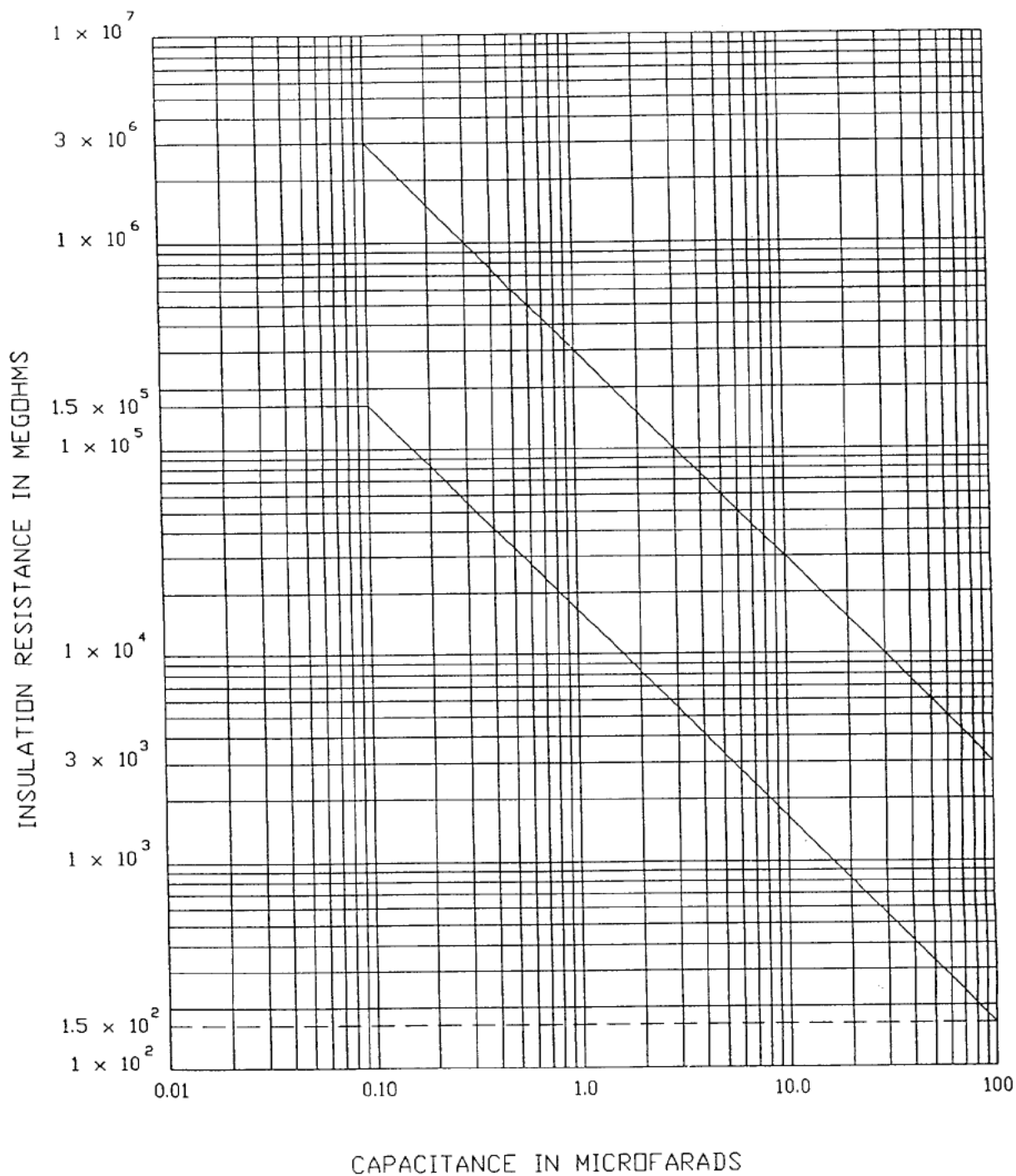

FIGURE 3. Insulation resistance versus capacitance value.

MIL-C-83421/4A

Marking: In accordance with MIL-C-83421.

Part or Identifying Number (PIN): Consists of the basic number of this specification sheet with a dash number coded as shown in the following:

	<u>M83421/04-</u>	<u>1</u>	<u>001</u>
Specification sheet number			
Single digit designating style (i.e., 1 = CRS11; 2 = CRS12; and 3 = CRS13)			
Nonsignificant dash number from table I			

Packaging: Capacitors will be furnished in tape and reel packaging when so specified in the ordering data.

Ⓐ CONCLUDING MATERIAL

Custodians:
Navy - EC
Air Force - 19
NASA - NA

Review activities:
Air Force - 85
DLA - ES

User activities:
Navy - AS, CG, MC, OS, SH

Preparing activity:
NASA - NA

Agent:
DLA - ES

(Project 5910-1723)