

MIL-C-81659B
2 August 1976
SUPERSEDING
MIL-C-81659A(NAVY)
21 July 1971

MILITARY SPECIFICATION
CONNECTORS, ELECTRICAL, RECTANGULAR
CRIMP CONTACTS,
GENERAL SPECIFICATION FOR

This specification is approved for use by all Departments and Agencies of the Department of Defense.

1. SCOPE

1.1 Scope. This specification covers two series of electrical, rectangular connectors with crimp type removable contacts. These connectors are provided with single, dual, triple, and quadruple insert shell configurations.

1.2 Classification. Connectors covered by this specification shall be of the following types, classes, series and shell designators.

1.2.1 Type description. The connector type shall be identified as follows:

- Type I - Short grommet seal (series 1 only).
- Type II - Standard grommet seal.
- Type III - Without grommet seal.
- Type IV - Without interfacial and grommet seals.

1.2.2 Class description. The connector class shall be identified as follows:

- Class 1: -65°C to +125°C.
- Class 2: -65°C to +200°C.

1.3 Military part number. The military part number shall consist of the letter "M", the basic number of the specification sheet, and coded numbers or letters as shown in the following example:



1.3.1 Basic part number. The basic part number shall be as shown on the applicable military specification sheet. Revision letters shall not be included.

1.3.2 Shell designator. The shell designator shall consist of a letter in accordance with the following:

- A - A connector having a shell configuration to accommodate a keystone insert.
- B - A connector having a shell configuration to accommodate a rectangular insert.

1.3.3 Series designator. The series designator shall consist of a one digit number in accordance with the following:

- Series 1 - Front release contacts.
- Series 2 - Rear release contacts.

1.3.4 Insert designator. The insert designator shall consist of a four digit number as shown on MS3157.

1.4 Polarization position. The polarization position of the connector shall be in accordance with table I. Polarizing hardware is depicted in figure 1a and 1b. All connectors shall be supplied with the polarizing hardware shipped loose. Polarization shall be accomplished by the user and the position number marked on the connector shell following the military part number (1.3).

MIL-C-81659B

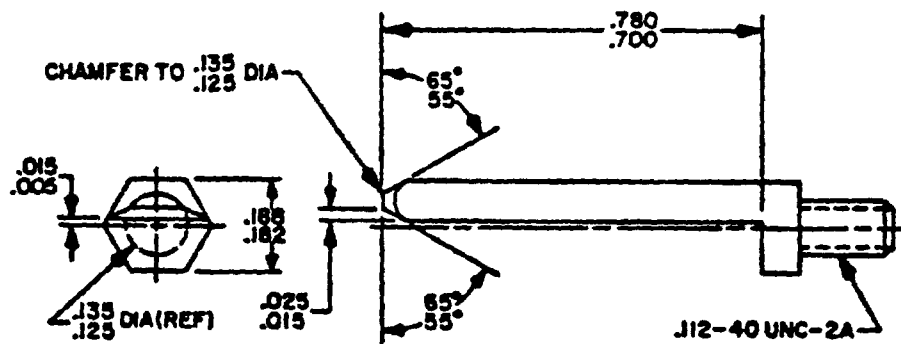

FIGURE 1A. Polarizing post.

INCHES	MM
.005	.13
.015	.38
.025	.64
.098	2.49
.108	2.74
.110	2.79
.112	2.84
.125	3.11
.130	3.30
.135	3.43
.182	4.62
.188	4.78
.220	5.59
.250	6.35
.700	17.78
.780	19.81

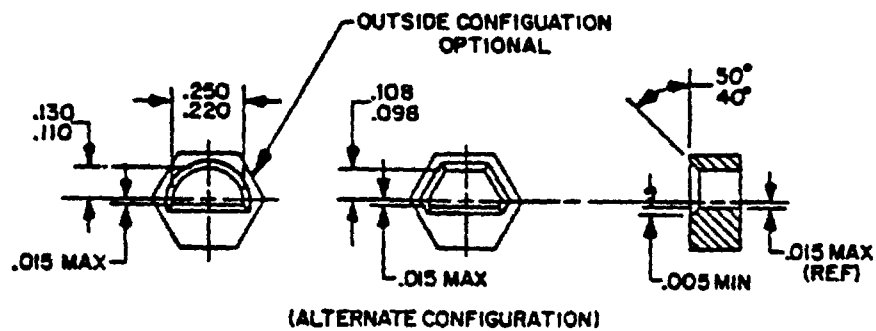

FIGURE 1B. Polarizing insert.

TABLE I. Polarization positions.



PLUG			RECEPTACLE			PLUG			RECEPTACLE						
POSITION	LEFT POST	CENTER POST	RIGHT POST	POSITION	LEFT KEY	CENTER KEY	RIGHT KEY	POSITION	LEFT POST	CENTER POST	RIGHT POST	POSITION	LEFT KEY	CENTER KEY	RIGHT KEY
00	—	—	—	00	—	—	—	50	2	2	3	50	6	3	3
01	1	1	1	01	4	4	4	51	3	2	3	51	6	3	2
02	2	1	1	02	4	4	3	52	4	2	3	52	6	3	1
03	3	1	1	03	4	4	2	53	5	2	3	53	6	3	6
04	4	1	1	04	4	4	1	54	6	2	3	54	6	3	3
05	5	1	1	05	4	4	6	55	1	2	4	55	1	3	4
06	6	1	1	06	4	4	3	56	2	2	4	56	1	3	3
07	1	1	6	07	5	4	4	57	3	2	4	57	1	3	2
08	2	1	6	08	5	4	3	58	4	2	4	58	1	3	1
09	3	1	6	09	5	4	2	59	5	2	4	59	1	3	6
10	4	1	6	10	5	4	1	60	6	2	4	60	1	3	3
11	5	1	6	11	5	4	6	61	1	2	3	61	2	3	4
12	6	1	6	12	5	4	5	62	2	2	3	62	2	3	3
13	1	1	5	13	6	4	4	63	3	2	3	63	2	3	2
14	2	1	5	14	6	4	3	64	4	2	3	64	2	3	1
15	3	1	5	15	6	4	2	65	5	2	3	65	2	3	6
16	4	1	5	16	6	4	1	66	6	2	3	66	2	3	5
17	5	1	5	17	6	4	6	67	1	2	2	67	3	3	4
18	6	1	5	18	6	4	3	68	2	2	2	68	3	3	3
19	1	1	4	19	1	4	4	69	3	2	2	69	3	3	2
20	2	1	4	20	1	4	3	70	4	2	2	70	3	3	1
21	3	1	4	21	1	4	2	71	5	2	2	71	3	3	6
22	4	1	4	22	1	4	1	72	6	2	2	72	3	3	5
23	5	1	4	23	1	4	6	73	1	3	1	73	4	2	4
24	6	1	4	24	1	4	5	74	2	3	1	74	4	2	3
25	1	1	3	25	2	4	4	75	3	3	1	75	4	2	2
26	2	1	3	26	2	4	3	76	4	3	1	76	4	2	1
27	3	1	3	27	2	4	2	77	5	3	1	77	4	2	6
28	4	1	3	28	2	4	1	78	6	3	1	78	4	2	5
29	5	1	3	29	2	4	6	79	1	3	6	79	5	2	4
30	6	1	3	30	2	4	5	80	2	3	6	80	5	2	3
31	1	1	2	31	3	4	4	81	3	3	6	81	5	2	2
32	2	1	2	32	3	4	3	82	4	3	6	82	5	2	1
33	3	1	2	33	3	4	2	83	5	3	6	83	5	2	6
34	4	1	2	34	3	4	1	84	6	3	6	84	5	2	5
35	5	1	2	35	3	4	6	85	1	3	5	85	6	2	4
36	6	1	2	36	3	4	5	86	2	3	5	86	6	2	3
37	1	2	1	37	4	3	4	87	3	3	5	87	6	2	2
38	2	2	1	38	4	3	3	88	4	3	5	88	6	2	1
39	3	2	1	39	4	3	2	89	5	3	5	89	6	2	6
40	4	2	1	40	4	3	1	90	6	3	5	90	6	2	5
41	5	2	1	41	4	3	6	91	1	3	4	91	1	2	4
42	6	2	1	42	4	3	5	92	2	3	4	92	1	2	3
43	1	2	6	43	5	3	4	93	3	3	4	93	1	2	2
44	2	2	6	44	5	3	3	94	4	3	4	94	1	2	1
45	3	2	6	45	5	3	2	95	5	3	4	95	1	2	6
46	4	2	6	46	5	3	1	96	6	3	4	96	1	2	5
47	5	2	6	47	5	3	6	97	1	3	3	97	2	2	4
48	6	2	6	48	5	3	5	98	2	3	3	98	2	2	3
49	1	2	5	49	6	3	4	99	3	3	3	99	2	2	2

NOTES:

1. Darkened portion indicates extended part of post in plug. Light portion indicates key hole in receptacle.
2. Mating faces shown with top up.

MIL-C-816598

MIL-C-816598

1.5 Wire range accommodations. Wire range accommodations of the contacts shall be as shown in table II.

TABLE II. Wire range accommodations.

Wire barrel sizes	Wire size	Insulation diameter range (inches)
22	26, 24, 22	.030 to .054
20	24, 22, 20	.040 to .071
16	20, 18, 16	.068 to .103
12	14, 12	.097 to .135

2. APPLICABLE DOCUMENTS

2.1 Issues of documents. The following documents, of the issue in effect on date of invitation for bids or request for proposal, form a part of this specification to the extent specified herein.

SPECIFICATIONS

FEDERAL

- | | |
|----------|---|
| QQ-A-250 | - Aluminum and Aluminum Alloy Plate and Sheet: General Specification for. |
| QQ-A-367 | - Aluminum Alloy Forgings. |
| QQ-A-591 | - Aluminum Alloy Die Casting. |
| QQ-P-416 | - Plating, Cadmium (Electro Deposited). |

MILITARY

- | | |
|-------------|---|
| MIL-M-14 | - Molding Plastics and Molded Plastic Parts, Thermosetting. |
| MIL-H-5606 | - Hydraulic Fluid, Petroleum Base, Aircraft, Missile, and Ordnance. |
| MIL-W-16878 | - Wire, Electrical, Insulated, High Temperature. |
| MIL-I-17214 | - Indicator, Permeability, Low-Mu (Go-No-Go). |
| MIL-C-22520 | - Crimping Tools, Terminal, Tool Kits, Hand or Power Actuated, Wire Termination, General Specification for. |
| MIL-L-23699 | - Lubricating Oil, Aircraft Turbine Engines, Synthetic Base. |
| MIL-M-24325 | - Molding Material, Plastic, Epoxy Compounds, Thermosetting. |
| MIL-C-26074 | - Coatings, Electroless Nickel, Requirements for. |
| MIL-C-39029 | - Contacts, Electrical, Connector. |
| MIL-C-45662 | - Calibration System Requirements. |
| MIL-C-55330 | - Connectors, Preparation for Delivery of. |

STANDARDS

MILITARY

- | | |
|---------------|---|
| MIL-STD-105 | - Sampling Procedures and Tables for Inspection by Attributes. |
| MIL-STD-454 | - Standard General Requirements for Electronic Equipment. |
| MIL-STD-1285 | - Marking of Electrical and Electronic Parts. |
| MIL-STD-1344 | - Test Methods for Electrical Connectors. |
| MS3156(NAVY) | - Tool, Insertion and Removal, Contact, MIL-C-81659 Connector (Series 2). |
| MS3157(NAVY) | - Insert Arrangements, MIL-C-81659 Electric Connector, Series 1 and 2. |
| MS3168(NAVY) | - Contacts, Electric, Coaxial, Pin, Crimpable, Size 1. |
| MS3169(NAVY) | - Contacts, Electric, Coaxial, Socket, Crimp, Size 1. |
| MS3170(NAVY) | - Contacts, Electric, Coaxial, Pin, Crimp, Size 3. |
| MS3171(NAVY) | - Contacts, Electric, Coaxial, Socket, Crimp, Size 3. |
| MS3172(NAVY) | - Contacts, Electric, Coaxial, Pin, Crimp, Size 5. |
| MS3173(NAVY) | - Contacts, Electric, Coaxial, Socket, Crimp, Size 5. |
| MS3174(NAVY) | - Contacts, Electric, Coaxial, Pin, Crimp, Size 7. |
| MS3175(NAVY) | - Contacts, Electric, Coaxial, Socket, Crimp, Size 7. |
| MS3176(NAVY) | - Contacts, Electric, Coaxial, Pin, Crimp, Size 9. |
| MS3177(NAVY) | - Contacts, Electric, Coaxial, Socket, Crimp, Size 9. |
| MS3447(NAVY) | - Tool, Insert-Extract, Wired Contact, Electric Connector, Size 20, 16, and 12. |
| MS27187(USAF) | - Plug, End, Seal, Electrical Connector. |
| MS27488 | - Plug, Sealing, Electric Connector. |
| MS90455(NAVY) | - Tool, Insertion, Contact, Connector. |
| MS90456(NAVY) | - Tool, Removal, Contact, Connector. |

(See supplement 1 for list of applicable specification sheets.)

(Copies of specifications, standards, drawings, and publications required by contractors in connection with specific procurement functions should be obtained from the procuring activity or as directed by the contracting officer).

3. REQUIREMENTS

3.1 Specification sheets. The individual item requirements shall be as specified herein and in accordance with the applicable specification sheets. In the event of any conflict between requirements of this specification and the specification sheets, the latter shall govern.

3.2 Qualification. Connectors furnished under this specification and the applicable specification sheet shall be products which are qualified for listing on the applicable qualified products list (QPL) at the time set for the opening of bids. (See 4.4 and 6.3.)

3.3 Materials. Materials shall be as specified herein. When a definite material is not specified, a material shall be used which will enable the connectors to meet the performance requirements of this specification. Acceptance or approval of any constituent material shall not be construed as an assurance of the acceptance of the finished product.

3.3.1 Dissimilar metals. When dissimilar metals are employed in intimate contact with each other, suitable protection against electrolytic corrosion shall be provided as specified in requirement 16 of MIL-STD-454.

3.3.2 Nonmagnetic materials. All parts shall be made from materials which pass the magnetic permeability test (see 3.5.1).

3.3.3 Shells. Shells shall be made from a high grade aluminum alloy. Diecasting materials shall conform to composition number 13, A13, 380, A380 or SC114A of QQ-A-591, or aluminum forging alloy conforming to QQ-A-367 or QQ-A-250.

3.3.4 Finish. The connector finish on all exposed metal parts, other than electrical contacts, insert retention plates, and corrosion resistant steel parts, shall be protected as shown in 3.3.4.1 and 3.3.4.2.

3.3.4.1 Class 1. Finish for class 1 connectors shall be cadmium plated per type II of QQ-P-416 (color to be natural (yellow) chromate).

3.3.4.2 Class 2. Finish for class 2 connectors shall be electroless nickel per MIL-C-26074.

3.3.4.3 Insert retaining plate. The insert retaining plate shall be black to indicate series I and a contrasting blue color to indicate series II.

3.3.4.4 Shell front face (series 2 only). The top edges of the plug shell and the area around the polarizing keys of the receptacle shell shall be provided with a 0.031 inch minimum wide blue stripe to indicate rear release contact retention system.

3.3.5 Inserts.

3.3.5.1 Rigid insert material. Rigid insert material shall conform to MIL-M-24325, MIL-M-14 type 6B1-30F, SDG-F or reinforced epoxy resin (Allied Chemical 1288 BX or equivalent), or reinforced phenolic resin per MIL-M-14.

3.3.5.2 Resilient insert material. Resilient insert material shall be a high grade elastomer having a shore "A" hardness between 35 and 65.

3.4 Design and construction. Connectors shall be of the design and construction specified (see 3.1). Bosses and barriers shall be used as necessary to meet electrical requirements.

3.4.1 Contacts. Unless otherwise specified, contacts shall conform to MIL-C-39029/2 or MIL-C-39029/11 for pins and MIL-C-39029/3 or MIL-C-39029/12 for sockets. A quantity of contacts consisting of the normal complement, plus one spare contact for connector arrangements having 25 contacts or less and two spares for arrangements over 26 contacts shall be included in the unit package. For indirect shipments, connectors may be ordered without contacts. (See 6.1.)

MIL-C-81659B

3.4.1.1 Coaxial contacts. Unless otherwise specified, coaxial contacts shall conform to MS3168 through MS3177. Users shall obtain coaxial contacts separately from the manufacturer of the connector being employed, except coaxial contacts for the "C2" and "C3" insert arrangements shall be supplied with the connector.

3.4.2 Grommet sealing plugs (type II). The grommet sealing plugs shall be in accordance with MS27488 or MS27187. Fifteen percent of the number of contacts, but not less than 1, shall be included in the unit package. Sealing plugs shall not be supplied for coaxial contact cavities. They must be obtained separately. For indirect shipments, connectors may be ordered without grommet sealing plugs. (See 6.1.)

3.4.3 Installing and removal tools. Individual contacts shall be installed with the applicable installing tool as specified in MS90455 and capable of being removed with the applicable removal tool conforming to MS90456 for series 1 connectors. For series 2 connectors, the applicable installing and removal tool conforming to MS3156 or MS3447 shall be used.

3.4.4 Contact crimping. A crimping tool conforming to MIL-C-22520 shall be used as applicable.

3.4.5 Insert. Inserts shall be designed and constructed with proper sections and radii in order that they will not crack, chip, or break in assembly or in normal service. Depressions used to achieve longer creepage paths shall not cause structural weakness, hollow or split inserts shall not be used, inserts shall be so designed that all air paths between adjacent contacts and contacts to shell are eliminated. The insert and wire sealing member shall be either one integral part or a bonded laminate construction. The wire sealing portion shall provide suitable sealing around the wire on the wire ranges and insulation diameter ranges shown on table II. The insert shall be positioned in the shell as specified (see 3.1).

3.4.5.1 Interfacial seal (types I, II, and III). Inserts with size 20, 16, 12, or coaxial pin contacts, or size 22 socket contacts, shall have a resilient face seal permanently bonded in place to provide an interfacial seal with the hard face of the mating insert in the mated condition (see 4.6.9).

3.4.6 Contact retention. The inserts shall be designed so that positive locking action of the contacts in the insert is provided. The contact retaining system shall be free of foreign material, adhesive, or any obstruction that would prevent smooth contact insertion and positive retention.

3.4.7 Insert arrangement. The number and arrangement of contacts shall be in accordance with MS3157.

3.4.8 Contact alignment and stability. With all contacts in place, the alignment of pin and socket contacts shall permit engagement irrespective of buildup of allowable tolerances on hole locations, distortion of contacts due to crimping and insert location in the shell.

3.4.9 Contact cavity identification. Designation of contacts shall be as specified in the applicable MS standards. Numerals shall be clearly legible. Marking shall be arranged to avoid confusion between contacts. All markings shall appear on the front and rear face of each insert. Insert marking on the front face of connectors with projecting contacts (including the 106 arrangement) is optional. Identification of the socket insert shall correspond with that of the mating pin insert. Ink marking is preferred but molded, raised, or recessed insert identification is permissible if located so as not to interface with sealing surfaces.

3.4.10 Shell. The shell shall be designed to positively retain the insert.

3.4.11 Polarization. Polarization of the mating plug and receptacle shall be accomplished by means of mating keys on the plug shell and keyways on the receptacle shell (see table I). Polarization shall be accomplished prior to contact engagement.

3.4.12 Interchangeability. Receptacles of a given size and design manufactured by one qualified source to the requirements of this specification, shall be capable of mating with associated plugs manufactured to the requirements of this specification by other qualified sources. The connector assemblies having the same part number shall be directly and completely interchangeable with each other with respect to installation and performance as specified herein.

3.4.12.1 Intermateability. Applicable figures 3 through 19 depict shell, interface, and contact location dimensions establishing intermateability control.

3.5 Performance. Connectors and accessories shall be designed to meet the performance requirements stated herein when tested in accordance with the specified method of section 4. All requirements and tests on mated connectors shall be performed with the mounting flanges at 0.297 ± 0.001 inches. Spacers may be used between the flanges to hold the position. A mated connector is defined as shown in figure 2.

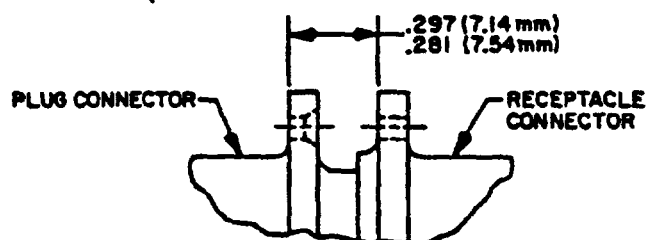

FIGURE 2. Definition of a mated connector.

3.5.1 Magnetic permeability. When tested in accordance with 4.6.2, the permeability of the basic connector assembly shall be less than 2.

3.5.2 Maintenance aging (releaseable contacts only). When pin and socket contacts are tested in accordance with 4.6.3, the individual contact installing and removal forces shall meet the requirements of 3.5.2.1.

3.5.2.1 Contact installing and removal forces. The installing force for any individual contact, using the applicable installing tool, shall not exceed 15 pounds. The removal force for any individual contact, using the applicable removal tool, shall not exceed 10 pounds.

3.5.3 Contact retention. When tested in accordance with 4.6.4, the contacts in wired (or unwired) unmated connectors shall withstand the axial load specified in table III without dislodging or damaging the contact, the connector insert or the contact retention mechanism. The axial displacement of the contact shall not exceed 0.012 inch.

TABLE III. Contact axial load.

Contact size	Axial load, pounds, minimum	
	Series 1	Series 2
22	15	15
20	20	20
16	25	25
12	30	30

MIL-C-816598

3.5.4 Insulation resistance. When tested in accordance with 4.6.5, the insulation resistance at 25°C (77°F) shall be greater than 5,000 megohms.

3.5.5 Thermal shock. When tested in accordance with 4.6.6, the temperature limits shall be -65°C +3°C -0°C to +125°C +3°C -0°C for class 1 connectors and +200°C +3°C -0°C for class 2 connectors. The connectors shall meet the subsequent test requirements listed in the applicable test sequence table.

3.5.6 Insulation resistance at elevated temperature. When tested in accordance with 4.6.7, the connectors shall show no evidence of physical damage and shall exhibit an insulation resistance greater than 1,000 megohms at 125°C and 200 megohms at 200°C.

3.5.7 Dielectric-withstanding voltage. When tested in accordance with 4.6.8, the connectors shall be capable of withstanding the applicable voltage shown in table IV without flashover unless otherwise specified (see 3.1). The maximum leakage current shall be 1 milliamperes.

TABLE IV. Dielectric withstanding voltage.

Altitude	Voltages, rms					
	Service rating A*			Service rating B*		
	Unmated	Mated		Unmated	Mated	
		Type I, II and III	Type IV		Type I, II and III	Type IV
Sea level	1,000	1,500	1,000	1,500	1,800	1,500
50,000 ft.	650	1,000	650	1,000	1,200	1,000

*Service ratings shown in MS3157.

3.5.8 Mating and unmating forces (connector assembly). When tested in accordance with 4.6.9, the mating and unmating forces shall not exceed 45 pounds per insert. (See 3.5.)

3.5.9 Humidity (type I, type III and type IV). When tested in accordance with 4.6.10, the mated connectors shall meet the dielectric withstanding voltage at sea level as specified in 3.5.7 and 100 megohms (minimum) insulation resistance.

3.5.10 Vibration. When tested in accordance with 4.6.11, the connectors shall show no evidence of cracking, breaking, loosening of parts, or loss of continuity of any contact circuit greater than one microsecond.

3.5.11 Shock (specified pulse). When tested in accordance with 4.6.12, the connectors shall show no evidence of cracking, breaking, loosening of parts, nor loss of continuity of any contact circuit greater than one microsecond.

3.5.12 Durability. When subjected to 500 cycles of mating and unmating in accordance with 4.6.13, the connectors shall show no evidence of damage detrimental to the operation of the connector and shall meet the mating and unmating forces as specified in 3.5.8.

3.5.13 Salt spray (corrosion). When tested in accordance with 4.6.14, exposure to a salt-laden atmosphere shall not cause sufficient corrosion to interfere with the mating and unmating force of the connectors.

3.5.14 Temperature life. When tested in accordance with 4.6.15, connectors shall withstand without evidence of damage 1,000 hours at an ambient temperature of 125°C ±3°C for class 1 and 200°C ±3°C for class 2.

3.5.15 Fluid immersion. When tested in accordance with 4.6.16, unmated connectors shall mate within the forces specified in 3.5.8.

3.5.16 Altitude-moisture injection (type II). When tested in accordance with 4.6.17, connectors shall have an insulation resistance of at least 100 megohms and shall maintain a dielectric withstanding voltage per table IV.

3.5.17 Insert retention. When tested in accordance with 4.6.18, unless otherwise specified (see 3.1), the connector-insert assembly shall retain its normal position in the connector shell for the specified load and shall show no signs of physical damage.

3.6 Marking. Each connector shall be legibly and permanently marked as specified (see 3.1) in accordance with MIL-STD-1285.

3.7 Workmanship. Connectors shall be processed in such a manner as to be uniform in quality and shall be free from pits, corrosion, cracks, rough edges, chips, and other defects that will affect life or serviceability.

4. QUALITY ASSURANCE PROVISIONS

4.1 Responsibility for inspection. Unless otherwise specified in the contract, the contractor is responsible for the performance of all inspection requirements as specified herein. Except as otherwise specified in the contract, the contractor may use his own or any other facilities suitable for the performance of the inspection requirements specified herein, unless disapproved by the Government. The Government reserves the right to perform any of the inspections set forth in the specification where such inspections are deemed necessary to assure supplies and services conform to prescribed requirements.

4.1.1 Test equipment and inspection facilities. Test and measuring equipment and inspection facilities of sufficient accuracy, quality and quantity to permit performance of the required inspection shall be established and maintained by the contractor. The establishment and maintenance of a calibration system to control the accuracy of the measuring and test equipment shall be in accordance with MIL-C-45662.

4.2 Classification of inspections. The inspections specified herein are classified as follows:

- a. Qualification inspection (see 4.4).
- b. Quality conformance inspection (see 4.5).

4.3 Inspection conditions. Unless otherwise specified herein, all inspections shall be performed with the test conditions specified in the "General Requirements" of MIL-STD-1344.

4.3.1 Preparation of crimp contact samples. The wire to be used shall be type E or type EE conforming to MIL-W-16878. The connector shall be fully wired with three feet minimum length of wire. Approximately half of the samples shall be wired with wire of the largest size applicable to the wire barrels and with a finished outside diameter approaching the upper limit of the applicable wire range as specified in table II. The other samples shall be wired with wire to the smallest size for which contacts are rated: i.e., for size 20 contacts use size 24 wire conforming to MIL-W-16878 type E.

4.3.2 Depth of engagement. Mated connectors shall be engaged as specified in 3.5.

4.4 Qualification inspection. Qualification inspection shall be performed at a laboratory acceptable to the Government (see 6.3) on sample units produced with equipment and procedures normally used in production.

4.4.1 Sample size. Six each completely assembled plugs or receptacle with single inserts of the greatest complement of contacts and one each completely assembled plug or receptacle with multiple inserts, for all other connector sizes for which qualification is desired, shall be submitted. The samples subjected to qualification testing shall be provided with counterpart connectors for those tests requiring mating assemblies. The counterpart connectors provided for this purpose shall be new previously qualified connectors or new connectors submitted for qualification testing. Suppliers not producing mating connectors shall submit substantiating certification data that tests were performed with qualified counter part connectors.

4.4.2 Inspection routine. The sample shall be subjected to the inspection specified in table V, in the order shown.

4.4.3 Failures. One or more failures shall be cause for refusal to grant qualification approval.

4.4.4 Retention of qualification. To retain qualification, the supplier shall forward a report at 9 month intervals to the qualifying activity. The qualifying activity shall establish the initial reporting date. The report shall consist of:

- a. A summary of the results of the tests performed for group A and B inspection indicating as a minimum the number of lots or samples that have passed and the number that have failed. The results of tests of all reworked lots shall be identified and accounted for.

MIL-C-816598

TABLE V. Qualification inspection.

Inspection	Requirement paragraph	Test method paragraph	Sample numbers						
			1	2	3	4	5	6	△
Examination of product	3.1, 3.3 through 3.4.12, 3.6 and 3.7	4.6.1	X	X	X	X	X	X	X
Magnetic permeability	3.5.1	4.6.2	X	X					
Maintenance aging	3.5.2	4.6.3	X	X	X	X	X	X	X
Contact insertion and removal forces	3.5.2.1	4.6.3	X	X	X	X	X	X	X
Contact retention	3.5.3	4.6.4	X	X	X	X	X	X	X
Contact insertion and removal forces	3.5.2.1	4.6.3	X	X	X	X	X	X	X
Insulation resistance	3.5.4	4.6.5	X	X	X	X	X	X	X
Thermal shock	3.5.5	4.6.6	X	X	X	X	X	X	X
Insulation resistance (elevated temperature)	3.5.6	4.6.7			X	X			
Dielectric withstanding voltage (sea level)	3.5.7	4.6.8	X	X	X	X	X	X	X
Mating and unmating force	3.5.8	4.6.9	X	X	X	X	X	X	X
Humidity (type I, type III, and type IV)	3.5.9	4.6.10					X	X	X
Vibration (mated)	3.5.10	4.6.11	X	X	X	X			
Shock (specified pulse)	3.5.11	4.6.12	X	X					
Durability	3.5.12	4.6.13	X	X					
Salt spray (corrosion)	3.5.13	4.6.14	X	X					
Temperature life	3.5.14	4.6.15			X	X			
Fluid immersion	3.5.15	4.6.16					X	X	
Mating and unmating force	3.5.8	4.6.9	X	X	X	X	X	X	X
Altitude-moisture injection (type II)	3.5.16	4.6.17	X	X					X
Insert retention	3.5.17	4.6.18	X	X					
Dielectric withstanding voltage (altitude)	3.5.7	4.6.8			X	X			
Examination of product	3.1, 3.3 through 3.4.12, 3.6 and 3.7	4.6.1	X	X	X	X	X	X	X

△ Additional samples of multiple insert connectors (see 4.4.1).

- b. At 18 month intervals, a summary of the results of tests performed for periodic inspection, group C, including the number and mode of failures. The summary shall include results of all periodic inspection tests performed and completed during the 18 month period. If the summary of the test results indicates nonconformance with specification requirements, and corrective action acceptable to the qualifying activity has not been taken, action may be taken to remove the failing product from the qualified products list.

Failure to submit the report within 30 days after the end of each 9 month period may result in loss of qualification for the product. In addition to the periodic submission of inspection data, the contractor shall immediately notify the qualifying activity at any time during the 9 month period that the inspection data indicates failure of the qualified product to meet the requirements of this specification. In the event that no production occurred during the reporting period, a report shall be submitted certifying that the company still has the capabilities and facilities necessary to produce the item. If during 2 consecutive reporting periods, there has been no production, the manufacturer may be required, at the discretion of the qualifying activity, to submit to requalification.

4.5 Quality conformance inspection.

4.5.1 Inspection of product for delivery. Inspection of product for delivery shall consist of group A inspection.

4.5.1.1 Group A inspection. Group A inspection shall consist of the examinations and test specified in table VI, in the order shown.

TABLE VI. Group A inspection.

Inspection	Requirement paragraph	Test method paragraph	AQL (percent defective)	
			Major	Minor
Visual and mechanical inspection	3.1, 3.3 through 3.4.12, 3.6 and 3.7	4.6.1	1.0	4.0
Dielectric withstanding voltage (sea level)	3.5.7	4.6.8.1	100% test	

4.5.1.1.1 Inspection lot. An inspection lot shall consist of all connectors covered by the same specification sheet produced under essentially the same conditions, and offered for inspection at one time.

4.5.1.1.2 Sampling plan. Statistical sampling and inspection shall be in accordance with MIL-STD-105 for general inspection level II. The acceptable quality level (AQL) shall be as specified in table VI. Major and minor defects shall be as defined in MIL-STD-105.

4.5.1.1.3 Rejected lots. If an inspection lot is rejected, the supplier may rework it to correct the defects, or screen out the defective units, and resubmit for reinspection. Resubmitted lots shall be inspected using tightened inspection, and shall not thereafter be tendered for acceptance unless the former rejection or requirement of correction is disclosed. Such lots shall be separate from new lots, and shall be clearly identified as reinspected lots.

4.5.2 Periodic inspection. Periodic inspection shall consist of groups B and C. Except where the results of these inspections show noncompliance with the applicable requirements (see 6.5) delivery of products which have passed groups B and C shall not be delayed pending the results of these periodic inspections.

4.5.2.1 Group B inspection. Group B inspection shall consist of the inspections specified in table VII, in the order shown, and shall be made on sample units which have been subjected to and have passed the group A inspection.

TABLE VII. Group B inspection.

Inspection	Requirement paragraph	Test method paragraph	Number of sample units to be tested	Number of defectives permitted
Maintenance aging	3.5.2	4.6.3	6	0
Insulation resistance	3.5.4	4.6.5	6	0
Insert retention	3.5.17	4.6.18	6	0

MIL-C-816598

4.5.2.1.1 Sampling plan. Six mating inserts with the greatest complement of contacts being produced, assembled in mating connector shells, shall be inspected. Inspection shall be performed every 9 months.

4.5.2.1.2 Disposition of sample units. Sample units which have been subjected to group B inspection shall not be delivered on a contract or purchase order.

4.5.2.2 Group C inspection. Group C inspection shall consist of the inspections specified in table VIII, in the order shown. Group C inspection shall be made on sample units selected from inspection lots which have passed the group A inspection.

TABLE VIII. Group C inspection.

Inspection	Requirement paragraph	Test method paragraph	Number of sample units to be inspected	Number of defectives permitted
Maintenance aging	3.5.2	4.6.3	6	0
Insulation resistance at elevated temperature	3.5.6	4.6.7	6	0
Vibration	3.5.10	4.6.11	6	0
Shock (specified pulse)	3.5.11	4.6.12	6	0
Humidity	3.5.9	4.6.10	6	0
Durability	3.5.12	4.6.13	6	0
Salt spray (corrosion)	3.5.13	4.6.14	6	0
Mating and unmating forces	3.5.8	4.6.9	6	0
Fluid immersion	3.5.15	4.6.16	6	0

4.5.2.2.1 Sampling plan. Every 18 months, six mating inserts with the greatest complement of contacts being produced, assembled in mating connector shells, shall be inspected.

4.5.2.2.2 Failures. If one or more sample units fail to pass group C inspection, the sample shall be considered to have failed.

4.5.2.2.3 Disposition of sample units. Sample units which have been subjected to group C inspection shall not be delivered on the contract or purchase order.

4.5.3 Packaging inspection. The sampling and inspection of the preservation-packaging, packing and container marking shall be in accordance with the requirements of MIL-C-55330.

4.6 Methods of examination and tests

4.6.1 Visual and mechanical examination. Connectors shall be examined to verify that the material, design and construction, marking and workmanship are in accordance with the applicable requirements (see 3.1, 3.3 through 3.4.12, 3.6 and 3.7).

4.6.2 Magnetic permeability (see 3.5.1) Permeability shall be checked with an instrument conforming to MIL-I-17214. The connectors shall be wired or unwired as convenient but shall not be carrying current.

4.6.3 Maintenance aging (see 3.5.2). Each wired contact shall be installed, removed and reinstalled using the applicable installing and removal tools. The connector shall then be mated and unmated 10 times. Twenty percent of the contacts, but not less than 4 contacts, in each plug and receptacle shall be subjected to nine additional cycles of removal-installation. The force to fully seat (and remove, where required) the cycled contacts in each plug and receptacle shall be measured during the third and ninth installation and removal (see 3.5.2.1).

4.6.4 Contact retention (see 3.5.3). The axial load as specified in table III shall be applied to the engaging end for series 2 and in either direction for series 1 of 20 percent of the contacts in wired or unwired unmated connectors. The axial rate of application shall be approximately one pound per second. Contact movement shall be measured after the contact is firmly seated on the retention member.

MIL-C-81659B

4.6.5 Insulation resistance (see 3.5.4). Unmated connectors shall be tested in accordance with method 3003 of MIL-STD-1344.

4.6.6 Thermal shock (see 3.5.5). Wired, mated, connectors shall be tested in accordance with method 1003 of MIL-STD-1344. Test condition B for class 1 connectors and test condition C for class 2 connectors shall be used. Upon completion of the last cycle, the connectors shall be returned to room ambient conditions for inspection.

4.6.7 Insulation resistance at elevated temperature (see 3.5.6). The insulation resistance of wired, assembled, mated connectors shall be measured in accordance with 4.6.5 except the connectors shall have been exposed to a temperature of +125°C +3°C -0°C for class 1 connectors or +200°C +3°C -0°C for class 2 connectors for a minimum of 30 minutes. After the test the resistance shall be measured while the connector is at the elevated temperature.

4.6.8 Dielectric-withstanding voltage (see 3.5.7). The connectors shall be tested in accordance with method 3001 of MIL-STD-1344. The connectors shall show no evidence of flashover when the applicable voltage at the simulated altitudes, are applied between all adjacent contacts and between shell and closest contacts. The voltage shall be applied at a rate not to exceed 500 volts per second until the applicable voltage of table IV is reached.

4.6.8.1 Dielectric-withstanding voltage - group A inspection. Unmated connectors shall be tested in accordance with 4.6.8, except that simulated contacts may be used and the period of application of voltage shall be 1 second minimum.

4.6.9 Mating and unmating force (see 3.5.8). The connectors shall be mated and unmated three times. During the third cycle, the force to mate and unmate the connector shall be measured.

4.6.10 Humidity (type I, type III and type IV)(see 3.5.9). The mated connectors shall be tested in accordance with method 1002, procedure type II of MIL-STD-1344 except that steps 7a and 7b are not required. During the entire final cycle, a 200 dc voltage potential shall be applied between the 3 closest pairs of contacts and between the shell and the 3 contacts closest to the shell. After the recovery period specified in MIL-STD-1344, the dielectric withstanding voltage at sea level and insulation resistance shall be tested in accordance with 4.6.8 and 4.6.5, respectively.

4.6.11 Vibration (see 3.5.10). The mated connectors shall be vibrated in accordance with method 2005, test condition IV of MIL-STD-1344. All contacts shall be series wired and connected to a suitable testing circuit with 0.1 ampere flowing through the contacts.

4.6.12 Shock (specified pulse)(see 3.5.11). The mated connectors shall be subjected to a shock test in accordance with method 2004 of MIL-STD-1344. Test condition letter will be A. All contacts shall be series wired and connected to a suitable testing circuit with 0.1 ampere flowing through the contacts. The shock test shall be repeated 3 times in both directions of the referenced 90 axis planes (a total of 18 drops).

4.6.13 Durability (see 3.5.12). The wired, assembled plugs and receptacles shall be subjected to 500 cycles of mating and unmating at a rate not to exceed 100 cycles per hour. The plug and receptacle shall be completely separated during each cycle. Connectors may be mated and unmated by machine.

4.6.14 Salt spray (corrosion)(see 3.5.13). The mated plugs and receptacles shall be subjected to a salt spray test in accordance with method 1001, test condition B, of MIL-STD-1344. Salt concentration shall be 5 percent.

4.6.15 Temperature life (see 3.5.14). The wired, assembled, and mated connectors shall be placed in a circulating air oven. The temperature limits and the time duration shall be as specified in 3.5.14. The sensing device used to monitor the temperature shall be placed on the shell of the connector.

4.6.16 Fluid immersion (see 3.5.15). Unmated counterpart connectors shall be immersed fully in the fluids specified in a and b. for the required periods. At least one pair of mating counterpart connectors shall be immersed in each fluid. After removal from the fluid, each pair of connectors shall remain for one hour in free air at room conditions in a position to allow the fluid to drain from the insert faces. Subsequent testing shall be performed on connectors mated with the same mating connectors used in previous testing.

- a. Hydraulic fluid conforming to MIL-H-5606 - 20 hours.
- b. Lubricating oil conforming to MIL-L-23699 - 20 hours.

MIL-C-81659B

4.6.17 Altitude - moisture injection (type II only)(see 3.5.16). Wired and mated connectors shall be subjected to 50,000 feet equivalent altitude. After 5 minutes stabilization at this altitude the pressure shall be increased to sea level at the rate of 10,000 feet per minute. This procedure constitutes one cycle. The air admitted into the test chamber shall be at least 93 percent humidity. This test shall consist of five cycles. The dielectric withstanding voltage test shall be performed as specified in 4.6.8 on the mated connector at the end of the first and fifth cycle. An acceptable method for humidifying the admitted air is as follows:

- a. Partially fill a laboratory flask with water. Close with a two hole stopper fitted with an air intake tube extending well below the water level and an outlet tube which is located in the top of the flask well above the water level.
- b. Place the flask in an oven, having a volume which exceeds the volume of the altitude chamber, and at a temperature of $190 \pm 5^\circ\text{F}$ ($88 \pm 3^\circ\text{C}$). Connect a tube between the outlet side of the flask and the altitude chamber providing a shut-off valve to control the flow as desired. CAUTION: Appropriate traps should be located between the altitude chamber and any instrumentation and the vacuum pump to prevent free moisture and/or water vapor from entering the low pressure monitoring or pumping system.

4.6.18 Insert retention (see 3.5.17). Unless otherwise specified (see 3.1), connector inserts shall withstand a uniformly distributed axial load of 120 pounds in either direction without being dislocated from their normal position in the connector shell. The load shall be increased gradually at a rate not to exceed 20 pounds per second until the specified load is reached.

5. PACKAGING

5.1 Packaging requirements. The requirements for packaging shall be in accordance with MIL-C-55330.

6. NOTES

6.1 Ordering data. Procurement documents should specify the following:

- a. Title, number, and date of this specification.
- b. Title, number, and date of the applicable specification sheet and the complete part number.
- c. For indirect shipments, these connectors may be furnished without contacts or grommet sealing plugs (see 3.4.1, 3.4.1.1, and 3.4.2).

6.2 Definitions. The following definitions shall apply:

- a. **PLUG CONNECTOR** - An electrical fitting with male shell with contacts, constructed to be electrically connected to a cable, conduit, coaxial line, cord, or wire to join with another electrical connector(s), and is designed to be mounted on a bulkhead, chassis or panel.
- b. **RECEPTACLE CONNECTOR** - An electrical fitting with female shell with contacts, constructed to be electrically connected to a cable, coaxial line, cord, or wire to join with another electrical connector(s), and is designed to be mounted on a bulkhead, wall, chassis, or panel.

6.3 Polarizing keys. Connectors covered by this specification are designed to be used with polarizing keys which polarize and insure contact alignment. Use of these connectors without polarizing keys is not recommended.

6.4 Qualification. With respect to products requiring qualification, awards will be made only for products which are at the time set for opening of bids, qualified for inclusion in the applicable qualified products list, whether or not such products have actually been so listed by that date. The attention of the contractors is called to these requirements and manufacturers are urged to arrange to have the products that they propose to offer to the Federal Government tested for qualification in order that they may be eligible to be awarded contracts or orders for the products covered by this specification.

6.4.1 Application for qualification. The activity responsible for the QPL for MIL-C-81659 is the Naval Air Systems Command. The Naval Weapons Support Center, Crane, Indiana has been designated by the Naval Air Systems Command as agent for establishment of the QPL. Request for information pertaining to and applications for qualification should be addressed to: Commanding Officer, Naval Weapons Support Center, Crane, Indiana 47522, Attention: Code 3074.

6.5 Noncompliance. If a sample fails to pass group B or C inspections, the manufacturer shall notify the qualifying activity and the cognizant inspection activity of such failure and take corrective action on the materials or processes, or both, as warranted, and on all units of product which can be corrected and which were manufactured under essentially the same conditions with essentially the same materials, processes, etc., and which are considered subject to the same failure. Acceptance and shipment of the product shall be discontinued until corrective action, acceptable to the qualifying activity has been taken. After the corrective action has been taken, groups B and C inspections shall be repeated on additional sample units (all inspection, or the inspection which the original sample failed, at the option of the qualifying activity). Group A inspection may be reinstated; however, final acceptance and shipment shall be withheld until the groups B and C inspections have shown that the corrective action was successful. In the event of failure after reinspection, information concerning the failure shall be furnished to the cognizant inspection activity and the qualifying activity.

Custodian:

Navy - AS

Army - EL

Air Force - 85

Review activities:

Navy - EC, OS

Air Force - 11, 99

OSA - ES

User activities:**Preparing activity:**

Navy - AS

Agent:

OSA - ES

(Project 5935-2066)

MIL-C-81659B

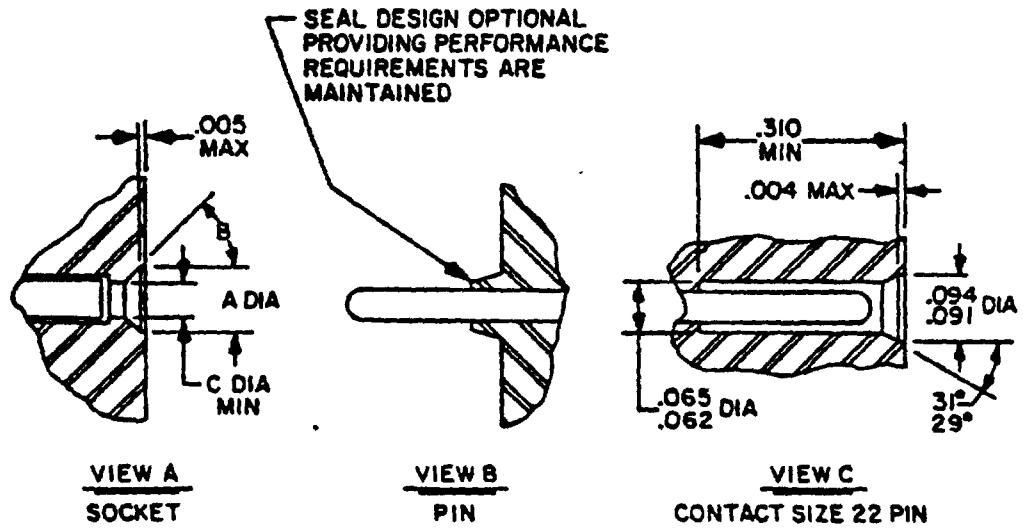

Contact size	A	B	C-Min
20	.110	50°	.050
	.090	40°	
16	.135	50°	.068
	.125	40°	
12	.180	50°	.099
	.170	40°	

INCHES	MM
.004	.10
.005	.13
.050	1.27
.062	1.57
.065	1.65
.068	1.73
.090	2.29
.091	2.31
.094	2.39
.099	2.51
.110	2.79
.125	3.18
.135	3.43
.170	4.32
.180	4.57
.310	7.87

NOTE: Size 22 socket contacts are exposed similar to view B, size 22 pin contacts are recessed as shown in view C.

FIGURE 3. Connector interface control dimensions.

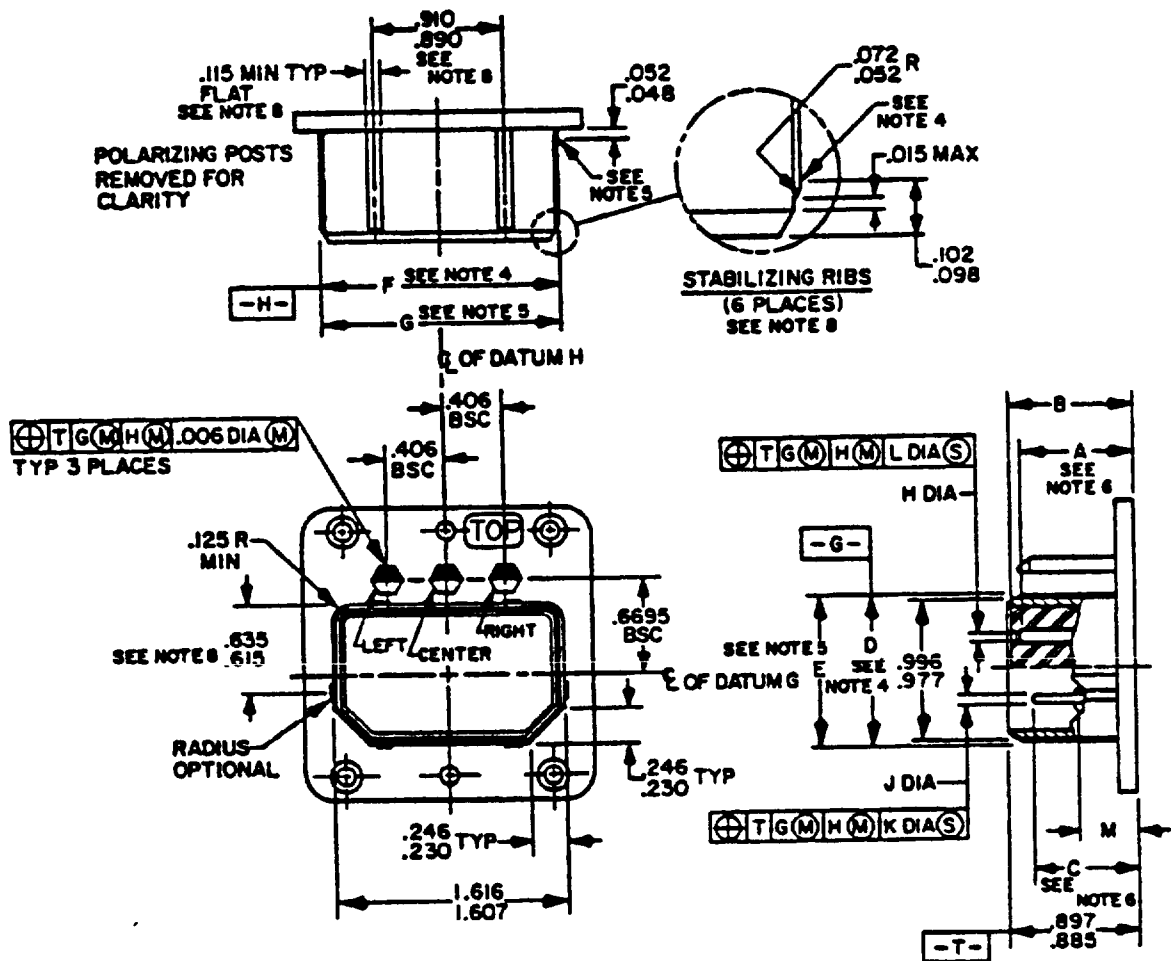

INCHES	MM	INCHES	MM	INCHES	MM	INCHES	MM	INCHES	MM
.006	.15	.098	2.49	.246	6.25	.885	22.48	.977	24.82
.015	.38	.102	2.59	.406	10.31	.890	22.61	.996	25.30
.048	1.22	.115	2.92	.615	15.62	.897	22.78	1.607	40.82
.052	1.32	.125	3.18	.635	16.13	.910	23.11	1.616	41.05
.072	1.83	.230	5.84	.6695	17.00				

FIGURE 4. Single plug connector intermateability control dimensions (Shell designator A)

MIL-C-81659B

Connector	A				B				C				D	E Max	F	G Max				
	22	20	16	12	22	20	16	12	22	20	16	12					22	20	16	12
Series 1	.882 (22.40)	.882 (22.40)	.882 (22.40)	.882 (22.40)	.942 (23.93)	.942 (23.93)	.942 (23.93)	.942 (23.93)	.816 (21.23)	.703 (17.86)	.881 (22.38)	.703 (17.86)	.996 (25.30)	.999 (25.37)	1.616 (41.05)	1.619 (41.12)				
Series 2	.802 (20.37)	.802 (20.37)	.802 (20.37)	.802 (20.37)	.902 (22.91)	.902 (22.91)	.902 (22.91)	.902 (22.91)	.777 (19.74)	.642 (16.31)	.820 (20.83)	.642 (16.31)	.996 (25.30)	.999 (25.37)	1.616 (41.05)	1.619 (41.12)				
Series 2	.736 (18.69)	.827 (20.97)	.782 (19.86)	.793 (20.14)	.893 (22.68)	.893 (22.68)	.893 (22.68)	.893 (22.68)	.843 (21.42)	.700 (17.78)	.874 (22.30)	.700 (17.78)	.996 (25.30)	.999 (25.37)	1.616 (41.05)	1.619 (41.12)				
All type IV	.688 (17.48)	.769 (19.53)	.735 (18.67)	.746 (18.95)	.865 (21.97)	.865 (21.97)	.865 (21.97)	.865 (21.97)	.865 (21.97)	.585 (14.86)	.746 (18.95)	.585 (14.86)	.996 (25.30)	.999 (25.37)	1.616 (41.05)	1.619 (41.12)				

Connector	H Dia (H)				J Dia (H)				K Dia (S)				L Dia (S)				M				
	22	20	16	12	22	20	16	12	22	20	16	12	22	20	16	12	22	20	16	12	
Series 1	.068 (1.73)	.122 (3.10)			.041 (1.04)	.0635 (1.61)	.095 (2.41)		.037 (.91)	.032 (.81)			.032 (.81)								
Series 2	.063 (1.60)	.050 (1.27)	.068 (1.73)	.099 (2.51)	.041 (1.04)	.0635 (1.61)	.095 (2.41)		.040 (1.02)	.045 (1.14)	.061 (1.55)	.061 (1.55)	.061 (1.55)	.045 (1.14)	.015 (.38)	.020 (.51)	.429 (10.90)	.343 (8.71)	.343 (8.71)	.343 (8.71)	.343 (8.71)
All type IV																	.377 (9.58)	.291 (7.39)	.291 (7.39)	.291 (7.39)	.291 (7.39)

- NOTES:
- Dimensions are in inches.
 - Metric equivalents (to the nearest .01 mm) are given for general information only and are based upon 1 inch = 25.4 mm.
 - Metric equivalents are in parentheses.
 - Dimensions D and F are taken at .102/.098 from front edge.
 - Dimensions E and G are taken at .052/.048 from flange.
 - For contact size #22, dimension A represents pin contacts and dimension C represents socket contacts.
 - The K diameter (S) includes the positional tolerance of the contact cavity plus the maximum amount of contact diametral splay.
 - It is not necessary for the shell to have stabilizing ribs providing D and F dimensions are maintained.

FIGURE 4. Single plug connector intermateability control dimensions - Continued.
(Shell - signet A)

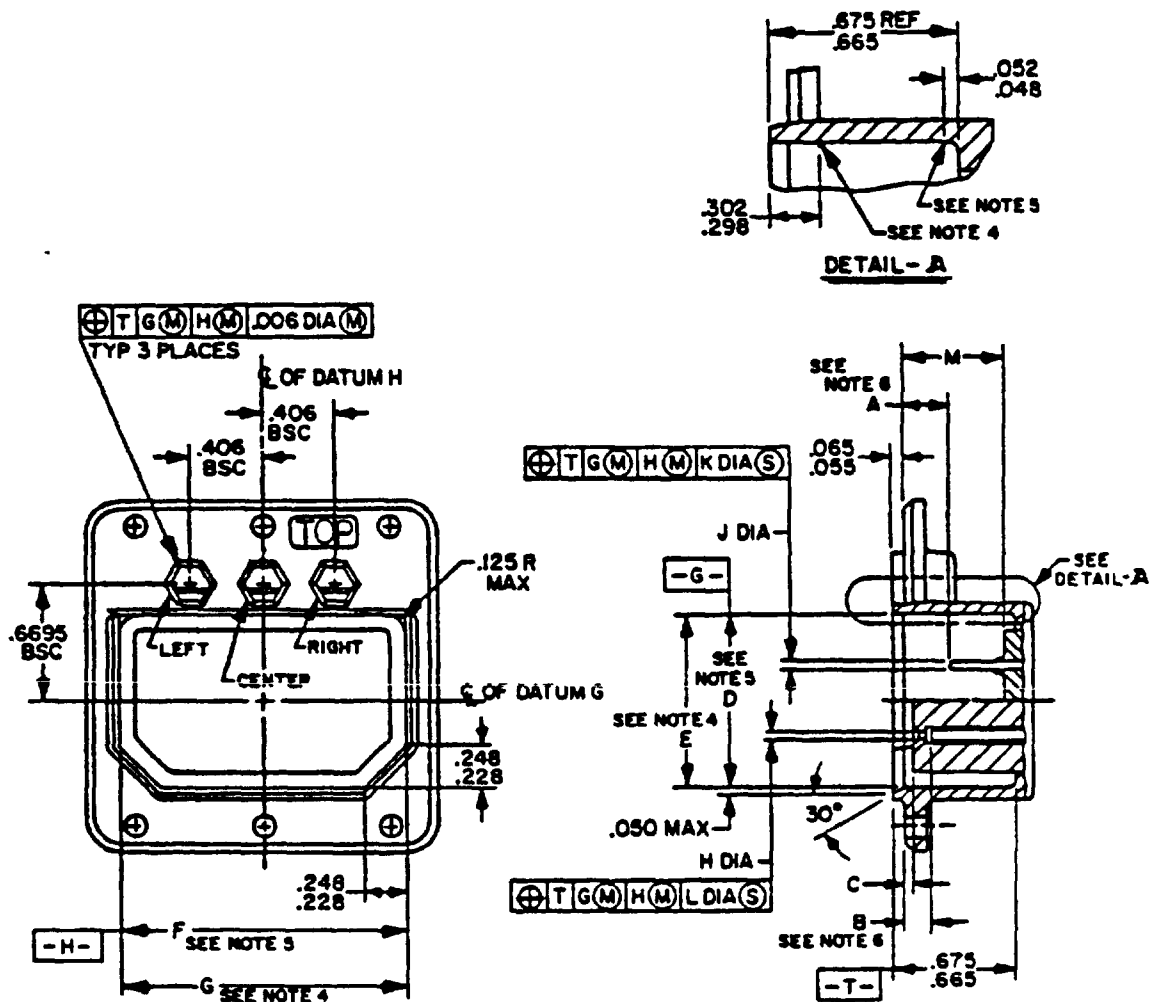

INCHES	MM	INCHES	MM	INCHES	MM	INCHES	MM	INCHES	MM
.006	.15	.052	1.32	.125	3.18	.298	7.57	.665	16.89
.048	1.22	.055	1.40	.228	5.79	.302	7.67	.6695	17.00
.050	1.27	.065	1.65	.248	6.30	.406	10.31	.675	17.14

FIGURE 5. Single receptacle connector intermateability control dimensions
(Shell designator A)

MIL-C-816598

Connector	A						B						C						D	E	F	G							
	20		16		12		22		20		16		12		22		20						16		12				
	(Inches)	(mm)	(Inches)	(mm)	(Inches)	(mm)	(Inches)	(mm)	(Inches)	(mm)	(Inches)	(mm)	(Inches)	(mm)	(Inches)	(mm)	(Inches)	(mm)					(Inches)	(mm)	(Inches)	(mm)			
Series 1	.222 (5.64)	.355 (9.02)	.177 (4.50)	.193 (4.90)	.193 (4.90)	.113 (2.87)	.113 (2.87)	.193 (4.90)	.193 (4.90)	.193 (4.90)	.113 (2.87)	.113 (2.87)	.093 (2.36)	.093 (2.36)	.093 (2.36)	.053 (1.35)	.053 (1.35)	.093 (2.36)	.093 (2.36)	.053 (1.35)	.053 (1.35)	.081 (2.06)	.081 (2.06)	.048 (1.22)	.048 (1.22)	1.004 (25.50)	1.007 (25.58)	1.624 (41.25)	1.632 (41.45)
Series 2	.250 (6.35)	.346 (8.79)	.165 (4.19)	.170 (4.32)	.165 (4.19)	.238 (6.04)	.238 (6.04)	.170 (4.32)	.170 (4.32)	.205 (5.21)	.205 (5.21)	.205 (5.21)	.175 (4.44)	.175 (4.44)	.175 (4.44)	.081 (2.06)	.081 (2.06)	.081 (2.06)	.081 (2.06)	.081 (2.06)	.081 (2.06)	.081 (2.06)	.081 (2.06)	.081 (2.06)	1.000 (25.40)	1.003 (25.48)	1.620 (41.15)	1.623 (41.22)	

Connector	H Dia (H)						J Dia (H)						I Dia (S)						L Dia (S)														
	20		16		12		22		20		16		12		22		20		16		12		22		20		16		12				
	(Inches)	(mm)	(Inches)	(mm)	(Inches)	(mm)	(Inches)	(mm)	(Inches)	(mm)	(Inches)	(mm)	(Inches)	(mm)	(Inches)	(mm)	(Inches)	(mm)	(Inches)	(mm)	(Inches)	(mm)	(Inches)	(mm)	(Inches)	(mm)	(Inches)	(mm)	(Inches)	(mm)			
Series 1	.068 (1.73)	.122 (3.10)		.041 (1.04)	.041 (1.04)	.0635 (1.61)	.0635 (1.61)	.095 (2.41)	.095 (2.41)	.095 (2.41)	.095 (2.41)	.032 (.81)	.032 (.81)	.032 (.81)	.032 (.81)	.032 (.81)	.032 (.81)	.032 (.81)	.032 (.81)	.032 (.81)	.032 (.81)	.032 (.81)	.032 (.81)	.032 (.81)	.032 (.81)	.032 (.81)	.032 (.81)	.032 (.81)	.032 (.81)	.032 (.81)	.032 (.81)		
Series 2	.063 (1.60)	.050 (1.27)	.068 (1.73)	.041 (1.04)	.041 (1.04)	.0635 (1.61)	.0635 (1.61)	.095 (2.41)	.095 (2.41)	.095 (2.41)	.095 (2.41)	.040 (1.02)	.040 (1.02)	.040 (1.02)	.040 (1.02)	.040 (1.02)	.040 (1.02)	.040 (1.02)	.040 (1.02)	.040 (1.02)	.040 (1.02)	.040 (1.02)	.040 (1.02)	.040 (1.02)	.040 (1.02)	.040 (1.02)	.040 (1.02)	.040 (1.02)	.040 (1.02)	.040 (1.02)	.040 (1.02)		
All type IV																																	

- NOTES:
1. Dimensions are in inches.
 2. Metric equivalents (to the nearest .01 mm) are given for general information only and are based upon 1 inch = 25.4 mm.
 3. Metric equivalents are in parentheses.
 4. Dimensions E and G are taken at .302/.298 from top edge.
 5. Dimensions D and F are taken at .052/.048 from bottom of cavity.
 6. For contact size #22, dimension A represents socket contacts and dimension B represents pin contacts.
 7. The K diameter (S) includes the positional tolerance of the contact cavity plus the maximum amount of contact diametral splay.

FIGURE 5. Single receptacle connector Interchangeability control dimensions - Continued. (Sheet Inator A)

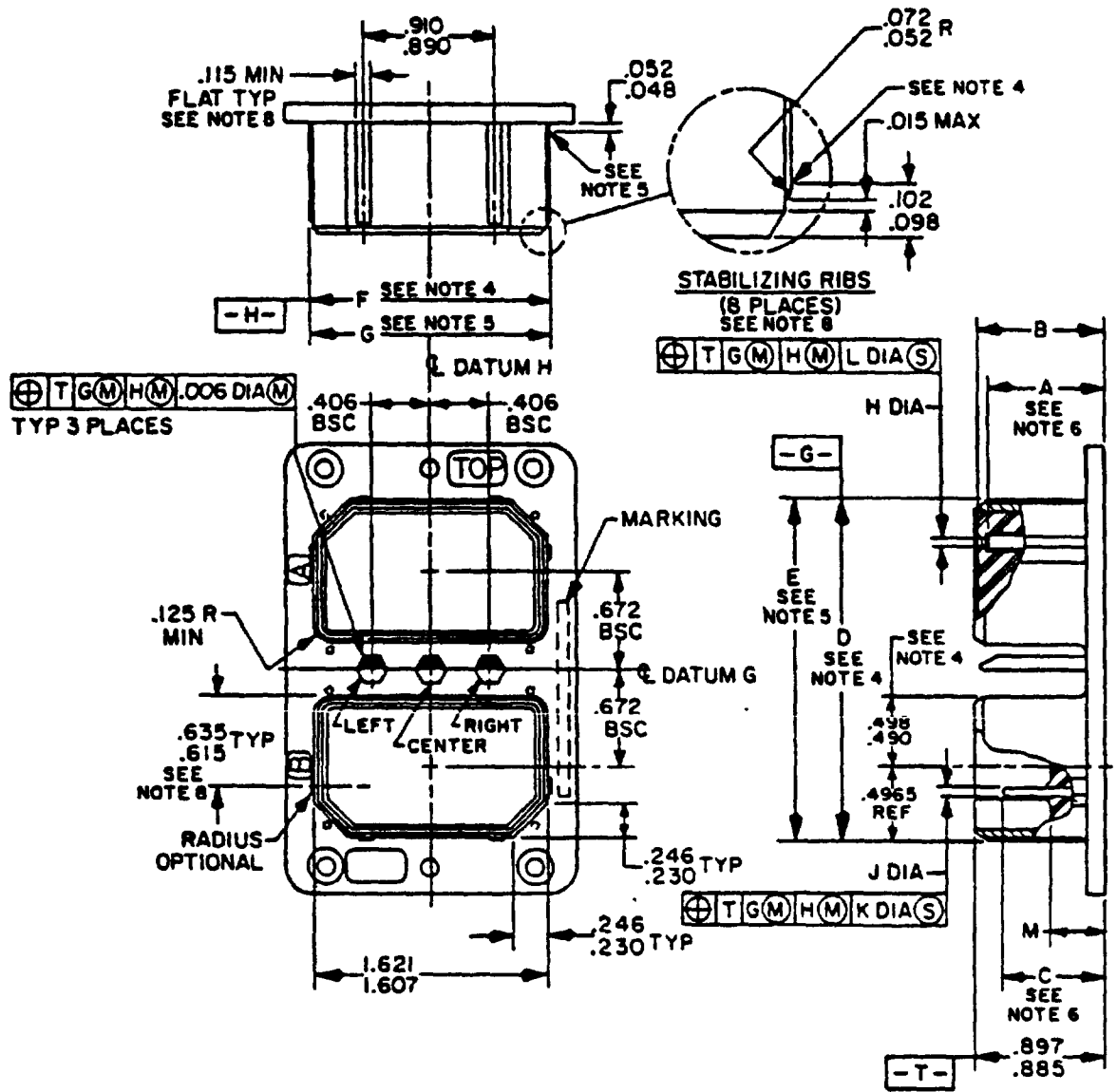

INCHES	MM	INCHES	MM	INCHES	MM	INCHES	MM	INCHES	MM
.006	.15	.098	2.49	.246	6.25	.615	15.62	.897	22.78
.015	.38	.102	2.59	.406	10.31	.635	16.13	.910	23.11
.048	1.22	.115	2.92	.490	12.45	.672	17.07	1.607	40.82
.052	1.32	.125	3.18	.4965	12.61	.885	22.48	1.621	41.17
.072	1.83	.230	5.84	.498	12.65	.890	22.61		

FIGURE 6. Dual plug connector intermateability control dimensions.
(Shell designator A)

MIL-C-81659B

Connector	A						B						C						D	E Max	F	G Max												
	20		16		12		22		20		16		12		22		20						16		12									
Series 1	.882 (22.40)	.882 (22.40)	.802 (20.37)	.802 (20.37)	.782 (20.00)	.782 (20.00)	.942 (23.93)	.942 (23.93)	.902 (22.91)	.902 (22.91)	.893 (22.68)	.893 (22.68)	.942 (23.93)	.942 (23.93)	.902 (22.91)	.902 (22.91)	.893 (22.68)	.893 (22.68)	.703 (17.86)	.703 (17.86)	.642 (16.31)	.642 (16.31)	.824 (20.83)	.824 (20.83)	2.339 (59.41)	2.339 (59.41)	2.342 (59.49)	2.342 (59.49)	1.621 (41.17)	1.621 (41.17)	1.617 (41.25)	1.617 (41.25)		
Series 2	.736 (18.69)	.736 (18.69)	.735 (18.67)	.735 (18.67)	.746 (19.05)	.746 (19.05)	.797 (20.24)	.797 (20.24)	.769 (19.53)	.769 (19.53)	.865 (21.97)	.865 (21.97)	.893 (22.68)	.893 (22.68)	.865 (21.97)	.865 (21.97)	.865 (21.97)	.865 (21.97)	.688 (17.48)	.688 (17.48)	.585 (14.86)	.585 (14.86)	.746 (18.95)	.746 (18.95)	2.335 (59.31)	2.335 (59.31)								

Connector	H Dia						J Dia						K Dia						L Dia						M												
	20		16		12		22		20		16		12		22		20		16		12		22		20		16		12								
Series 1	.068 (1.73)	.122 (3.10)					.041 (1.04)	.0635 (1.61)	.095 (2.41)				.032 (.81)	.032 (.81)																							
Series 2	.063 (1.60)	.068 (1.73)	.099 (2.51)	.061 (1.55)	.061 (1.55)	.061 (1.55)	.041 (1.04)	.0635 (1.61)	.095 (2.41)	.0095 (.24)	.040 (1.02)	.045 (1.14)	.061 (1.55)	.0075 (.19)	.010 (.25)	.015 (.38)	.020 (.51)																				
All type IV																																					

- NOTES:
- Dimensions are in inches
 - Metric equivalents (to the nearest .01 mm) are given for general information only and are based upon 1 inch = 25.4 mm.
 - Metric equivalents are in parentheses.
 - Dimensions D, F, .4965 Ref. and .498/.490 are taken at .102/.098 from top edge.
 - Dimensions E and G are taken at .052/.048 from flange.
 - For contact size #22, dimension A represents pin contacts and dimension C represents socket contacts.
 - The K diameter $\text{\textcircled{S}}$ includes the positional tolerance of the contact cavity plus the maximum amount of contact diameter splay.
 - It is not necessary for the shell to have stabilizing ribs providing D and F dimensions are maintained.

FIGURE 6. Dual plug connector intermateability control dimensions - Continued.
(Shell design for A)

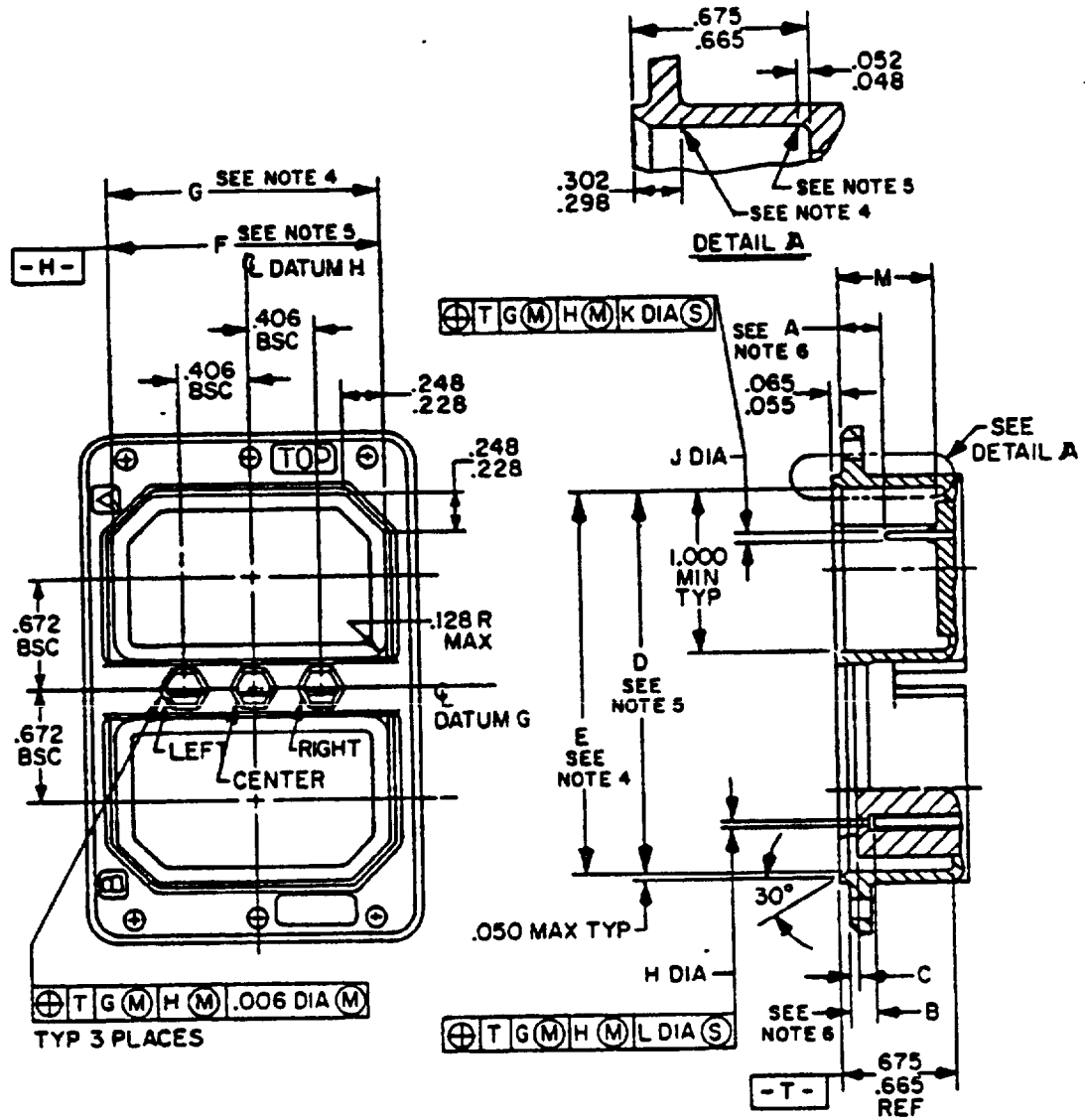

FIGURE 7. Dual receptacle connector intermateability control dimensions.
(Shell designator A)

MIL-C-81659B

Connector	A						B						C						D	E	F	G				
	20		16		12		22		20		16		12		22		20						16		12	
	22	20	16	12	22	20	16	12	22	20	16	12	22	20	16	12	22	20					16	12	22	20
Series 1	.222 (5.64)	.355 (9.02)	.177 (4.50)		.193 (4.90)	.193 (4.90)	.193 (4.90)		.093 (2.36)	.093 (2.36)	.093 (2.36)		.093 (2.36)	.093 (2.36)	.093 (2.36)		2.347 (59.61)	2.350 (59.69)	1.629 (41.38)				1.637 (41.58)			
Series 2	.250 (6.35)	.346 (8.79)	.165 (4.19)		.238 (6.04)	.170 (4.32)	.205 (5.21)		.175 (4.44)	.081 (2.06)	.081 (2.06)		.081 (2.06)	.081 (2.06)	.081 (2.06)		2.343 (59.51)	2.346 (59.59)	1.625 (41.28)				1.628 (41.35)			

Connector	H Dia (H)						J Dia (H)						K Dia (S)						L Dia (S)						M							
	20		16		12		22		20		16		12		22		20		16		12		22		20		16		12			
	22	20	16	12	22	20	16	12	22	20	16	12	22	20	16	12	22	20	16	12	22	20	16	12	22	20	16	12	22	20	16	12
Series 1	.063 (1.60)	.122 (3.10)			.041 (1.04)	.0635 (1.61)			.095 (2.41)				.032 (.81)	.032 (.81)			.032 (.81)	.032 (.81)														
Series 2	.063 (1.60)	.050 (1.27)	.068 (1.73)		.041 (1.04)	.0635 (1.61)	.099 (2.51)		.095 (2.41)	.061 (1.55)	.041 (1.04)	.061 (1.55)	.040 (1.02)	.045 (1.14)	.061 (1.55)	.0075 (.19)	.010 (.25)	.015 (.38)	.020 (.51)						.561 (14.25)	.647 (16.43)	.511 (12.98)	.597 (15.16)	.647 (16.43)	.597 (15.16)	.647 (16.43)	
All type IV																																

- NOTES:
- Dimensions are in inches.
 - Metric equivalents (to the nearest .01 mm) are given for general information only and are based upon 1 inch = 25.4 mm.
 - Metric equivalents are in parentheses.
 - Dimensions E and G are taken at .302/.298 from top edge.
 - Dimensions D and F are taken at .052/.048 from bottom of cavity.
 - For contact size #22, dimension A represents socket contacts and dimension B represents pin contacts.
 - The K diameter (S) includes the positional tolerance of the contact cavity plus the maximum amount of contact diametral splay.

FIGURE 7 Dual receptacle connector intermateability control dimensions - Continued. (Shell designator A)

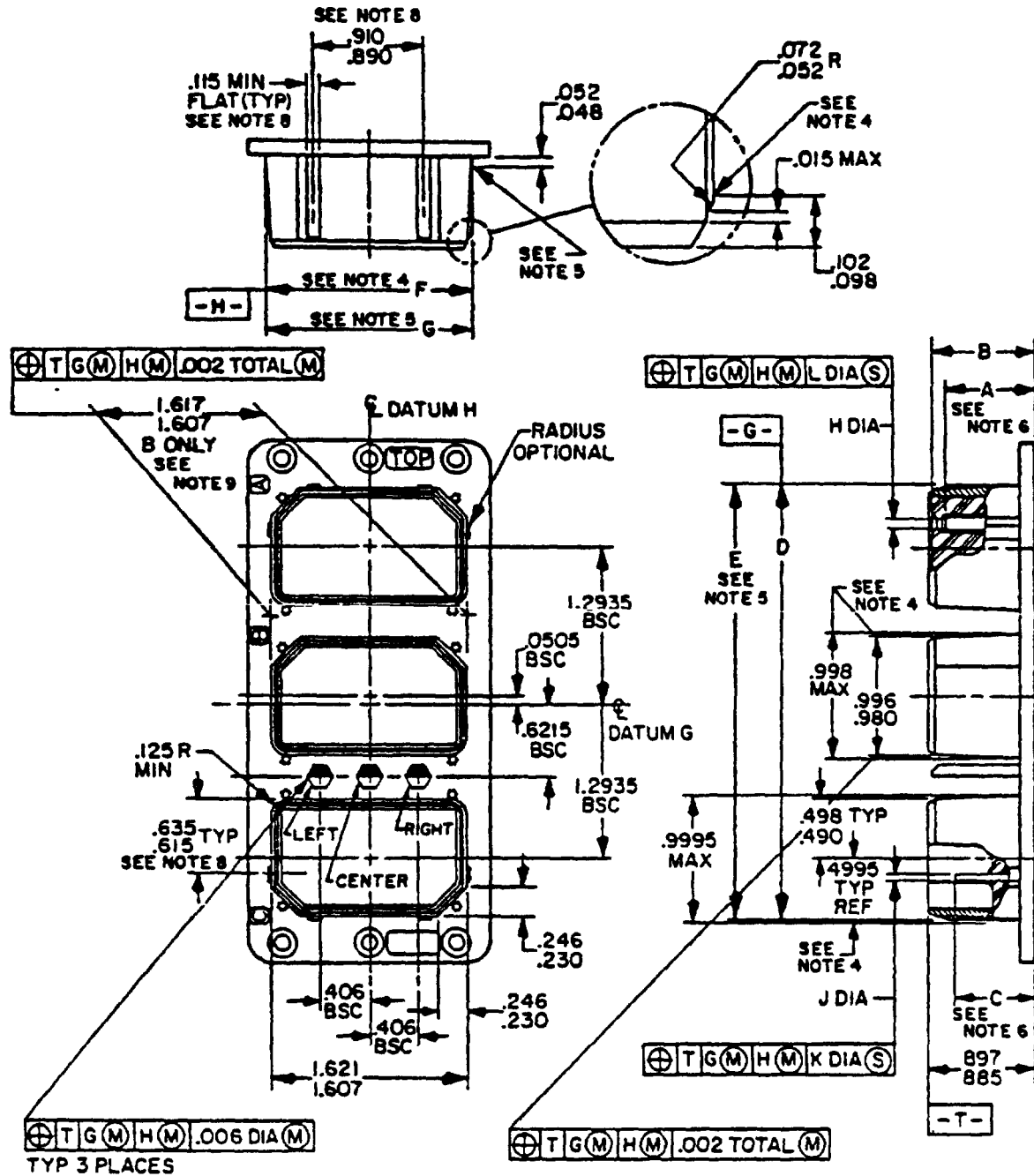

INCHES	MM	INCHES	MM	INCHES	MM	INCHES	MM	INCHES	MM
.002	.05	.098	2.49	.490	12.45	.885	22.48	.998	25.35
.006	.15	.102	2.59	.498	12.65	.890	22.61	.9995	25.39
.015	.38	.115	2.92	.4995	12.69	.897	22.78	1.2935	32.85
.048	1.22	.125	3.18	.615	15.62	.910	23.11	1.607	40.82
.0505	1.28	.230	5.84	.6215	15.79	.980	24.89	1.617	41.07
.052	1.32	.246	6.25	.635	16.13	.996	25.30	1.621	41.17
.072	1.83	.406	10.31						

FIGURE 8. Triple plug connector intermateability control dimensions
 (Shell designator A)

MIL-C-816598

Connector	A				B				C				D	E Max	F	G Max
	22	20	16	12	22	20	16	12	22	20	16	12				
Series 1	.882 (22.40)	.882 (22.40)	.882 (22.40)	.882 (22.40)	.942 (23.93)	.942 (23.93)	.942 (23.93)	.942 (23.93)	.836 (21.23)	.703 (17.86)	.881 (22.36)		3.589 (91.16)	3.592 (91.24)	1.621 (41.17)	1.624 (41.25)
Series 2	.802 (20.37)	.802 (20.37)	.802 (20.37)	.802 (20.37)	.902 (22.91)	.902 (22.91)	.902 (22.91)	.902 (22.91)	.777 (19.74)	.642 (16.31)	.820 (20.83)		3.583 (91.01)		1.617 (41.07)	
	.736 (18.69)	.827 (21.00)	.782 (19.86)	.793 (20.14)	.893 (22.68)	.893 (22.68)	.893 (22.68)	.893 (22.68)	.737 (18.72)	.700 (17.78)	.824 (20.93)	.824 (20.93)				
	.688 (17.48)	.769 (19.53)	.735 (18.67)	.746 (18.95)	.865 (21.97)	.865 (21.97)	.865 (21.97)	.865 (21.97)	.688 (17.48)	.585 (14.86)	.746 (18.95)	.746 (18.95)				

Connector	H Dia (H)				J Dia (H)				K Dia (S)				L Dia (S)			
	22	20	16	12	22	20	16	12	22	20	16	12	22	20	16	12
Series 1	.068 (1.73)	.122 (3.10)			.041 (1.04)	.0635 (1.61)	.095 (2.41)		.032 (.81)	.032 (.81)			.032 (.81)	.032 (.81)		
Series 2	.063 (1.60)	.050 (1.27)	.068 (1.73)	.099 (2.51)	.061 (1.55)	.0635 (1.61)	.095 (2.41)	.061 (1.55)	.040 (1.02)	.045 (1.14)	.045 (1.14)	.0075 (.19)	.061 (1.55)	.010 (.25)	.015 (.38)	.020 (.51)

- NOTES:
- Dimensions are in inches.
 - Metric equivalents (to the nearest .01 mm) are given for general information only and are based upon 1 inch = 25.4 mm.
 - Metric equivalents are in parentheses.
 - Dimensions D, F, .995/.980 and .495 Ref. are taken at .102/.098 from top edge.
 - Dimensions E and G are taken at .052/.048 from flange.
 - For contact size #22, dimension A represents pin contacts and dimension C represents socket contacts.
 - The K diameter (S) includes the positional tolerance of the contact cavity plus the maximum amount of contact diametral splay.
 - It is not necessary for the shell to have stabilizing ribs providing D and F dimensions are maintained.
 - Dimension 1.617/1.607 for "B" insert location is taken at .102/.098 from top edge. It shall be 1.617 max. at .052/.048 from the flange.

FIGURE 8. Triple plug connector intermateability control dimensions - Continued.
(Shell designator A)

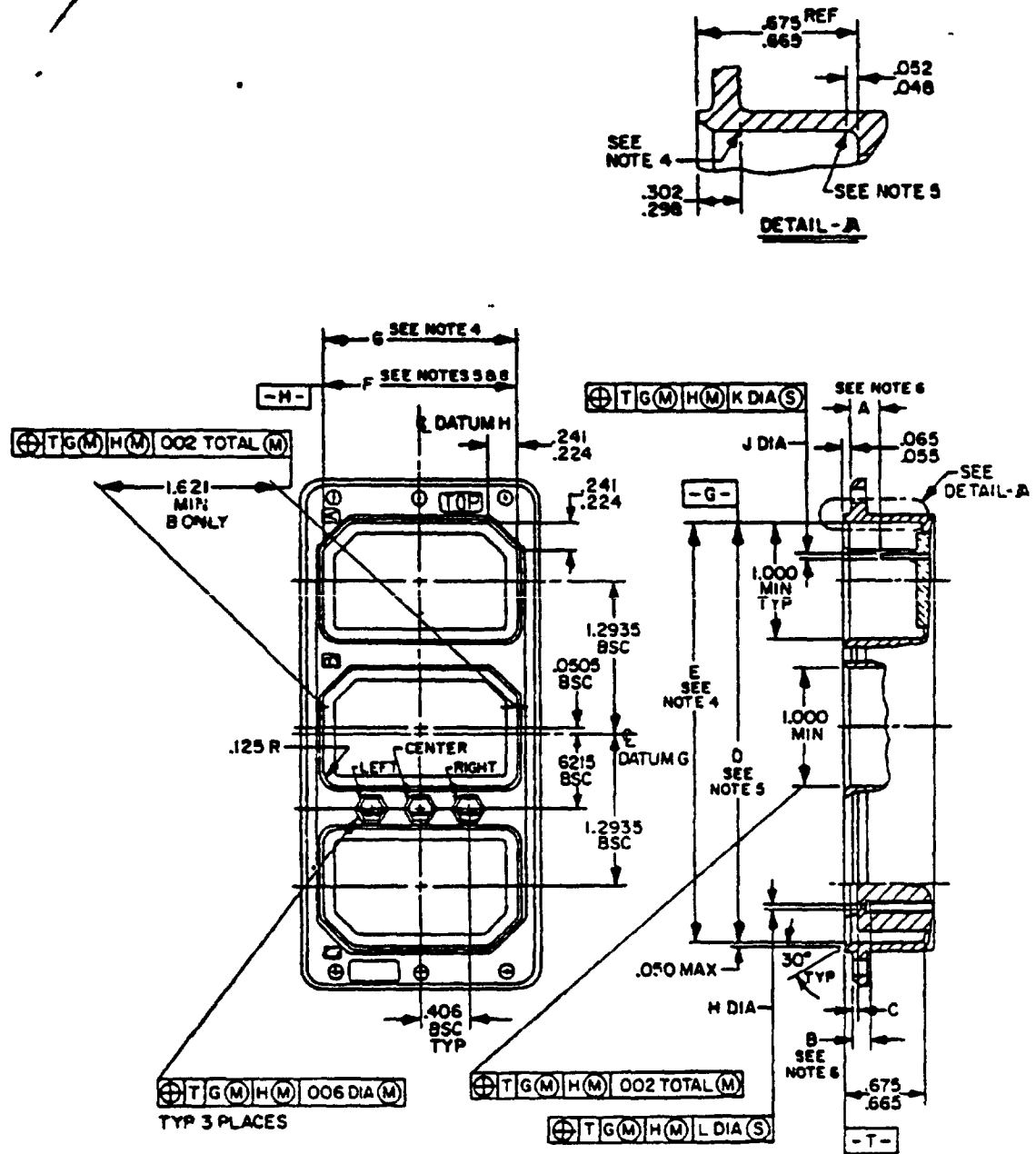

INCHES	MM	INCHES	MM	INCHES	MM	INCHES	MM	INCHES	MM
.002	.05	.0505	1.28	.125	3.18	.302	7.67	.675	17.14
.006	.15	.052	1.32	.224	5.69	.406	10.31	1.000	25.40
.048	1.22	.055	1.40	.241	6.12	.6215	15.79	1.2935	32.85
.050	1.27	.065	1.65	.298	7.57	.665	16.89	1.621	41.17

FIGURE 9 Triple receptacle connector intermateability control dimensions (Shell designator A)

MIL-C-816598

Connector	A				B				C				D	E	F	G
	22	20	16	12	22	20	16	12	22	20	16	12				
Series 1	.222 (5.64)	.355 (9.02)	.177 (4.50)	.193 (4.90)	.193 (4.90)	.193 (4.90)	.193 (4.90)	.193 (4.90)	.093 (2.36)	.093 (2.36)	.093 (2.36)	.093 (2.36)	3.595 (91.31)	3.598 (91.39)	1.629 (41.38)	1.637 (41.58)
Series 2	.155 (3.94)	.288 (7.32)	.110 (2.79)	.113 (2.87)	.113 (2.87)	.113 (2.87)	.113 (2.87)	.113 (2.87)	.053 (1.35)	.053 (1.35)	.053 (1.35)	.053 (1.35)	3.589 (91.16)	3.590 (91.19)	1.621 (41.17)	1.628 (41.35)
	.250 (6.35)	.346 (8.79)	.165 (4.19)	.238 (6.04)	.170 (4.32)	.205 (5.21)	.205 (5.21)	.205 (5.21)	.175 (4.44)	.081 (2.06)	.081 (2.06)	.081 (2.06)				
	.205 (5.21)	.241 (6.12)	.104 (2.64)	.104 (2.64)	.115 (2.92)	.146 (3.71)	.146 (3.71)	.146 (3.71)	.137 (3.48)	.048 (1.22)	.048 (1.22)	.048 (1.22)				

Connector	K Dia (H)				J Dia (H)				K Dia (S)				L Dia (S)			
	22	20	16	12	22	20	16	12	22	20	16	12	22	20	16	12
Series 1	.068 (1.73)	.068 (1.73)	.068 (1.73)	.068 (1.73)	.041 (1.04)	.041 (1.04)	.041 (1.04)	.041 (1.04)	.032 (.81)	.032 (.81)	.032 (.81)	.032 (.81)	.032 (.81)	.032 (.81)	.032 (.81)	.032 (.81)
Series 2	.063 (1.60)	.050 (1.27)	.068 (1.73)	.099 (2.51)	.061 (1.55)	.041 (1.04)	.0635 (1.61)	.095 (2.41)	.0095 (.24)	.040 (1.02)	.045 (1.14)	.061 (1.55)	.0075 (.19)	.010 (.25)	.015 (.38)	.020 (.51)

NOTES:

- Dimensions are in inches.
- Metric equivalents (to the nearest .01 mm) are given for general information only and are based upon 1 inch = 25.4 mm.
- Metric equivalents are in parentheses.
- Dimensions E and G are taken at .302/.298 from top edge.
- Dimensions D and F are taken at .052/.048 from bottom of cavity.
- For contact size #22, dimension A represents socket contacts and dimension B represents pin contacts.
- The K diameter (S) includes the positional tolerance of the contact cavity plus the maximum amount of contact diameter play.
- Dimension F applies to cavities A and C only.

FIGURE 9 Triple receptacle connector interchangeability control dimensions - Continued.
(Shell diameter A)

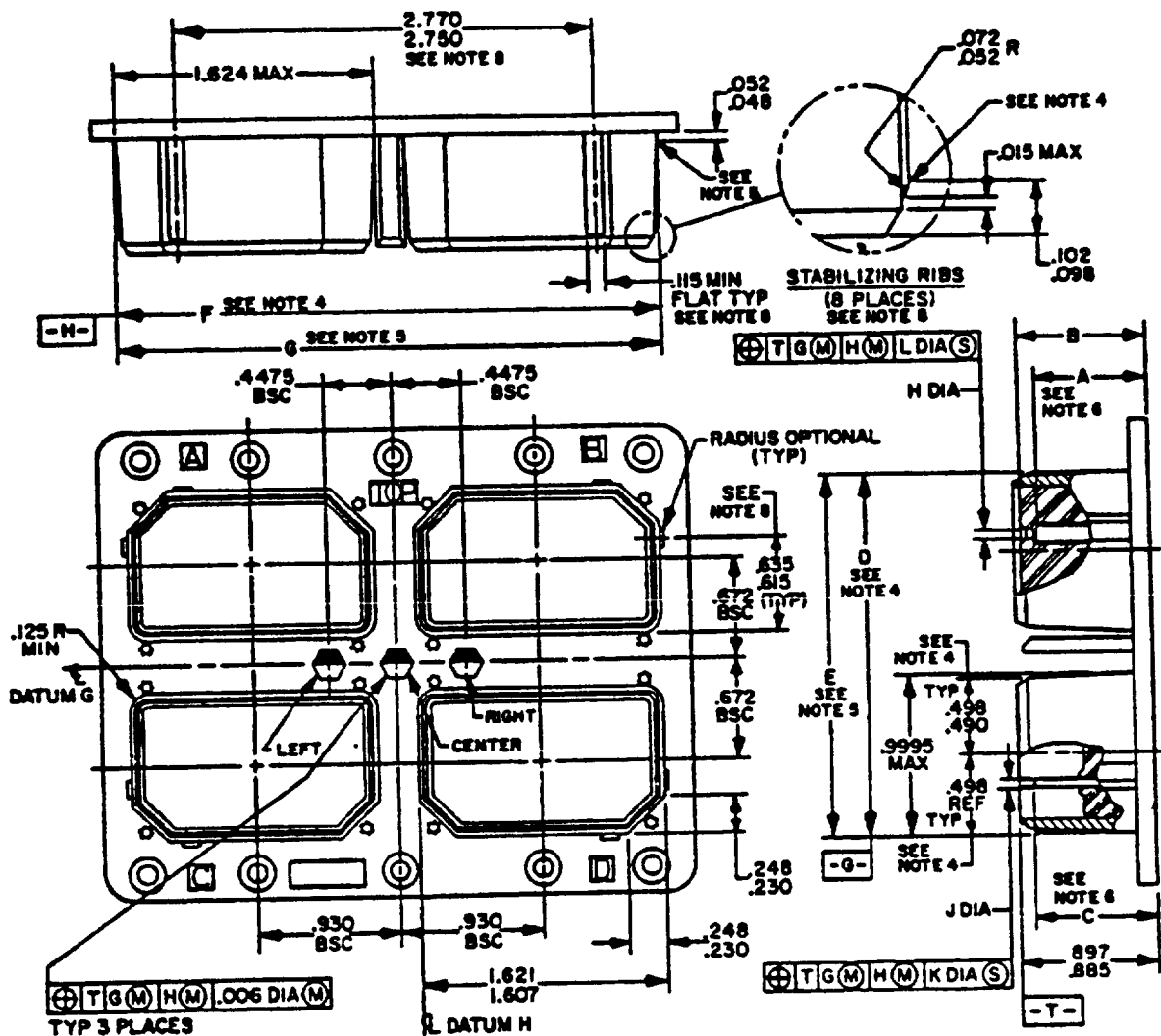

INCHES	MM	INCHES	MM	INCHES	MM	INCHES	MM	INCHES	MM
.006	.15	.102	2.59	.4475	11.37	.672	17.07	1.607	40.82
.015	.38	.115	2.92	.490	12.45	.885	22.48	1.621	41.17
.048	1.22	.125	3.18	.498	12.65	.897	22.78	1.624	41.25
.052	1.32	.230	5.84	.615	15.62	.930	23.62	2.750	69.85
.072	1.83	.248	6.30	.635	16.13	.9995	25.39	2.770	70.36
.098	2.49								

FIGURE 10. Quadruple plug connector intermateability control dimensions. (Shell designator A)

MIL-C-81659B

Connector	A				B				C				D	E Max	F	G Max
	22	20	16	12	22	20	16	12	22	20	16	12				
Series 1	.882 (22.40)	.882 (22.40)	.882 (22.40)	.882 (22.40)	.942 (23.93)	.942 (23.93)	.942 (23.93)	.942 (23.93)	.836 (21.23)	.703 (17.86)	.681 (22.38)		2.345 (59.56)	2.348 (59.64)	3.492 (88.70)	3.495 (88.77)
Series 2	.736 (18.69)	.827 (21.00)	.782 (19.86)	.793 (20.14)	.893 (22.68)	.893 (22.68)	.893 (22.68)	.893 (22.68)	.737 (18.72)	.700 (17.78)	.824 (20.93)	.824 (20.93)	2.339 (59.41)		3.486 (88.54)	

Connector	H Dia (H)			J Dia (H)			K Dia (S)			L Dia (S)		
	22	20	16	22	20	16	22	20	16	22	20	16
Series 1	.068 (1.73)	.122 (3.10)		.041 (1.04)	.0635 (1.61)	.095 (2.41)	.032 (.81)	.032 (.81)		.032 (.81)	.032 (.81)	
Series 2	.063 (1.60)	.050 (1.27)	.068 (1.73)	.061 (1.55)	.041 (1.04)	.095 (2.41)	.040 (1.02)	.045 (1.14)	.061 (1.55)	.0075 (.19)	.010 (.25)	.020 (.51)

- NOTES:
- Dimensions are in inches.
 - Metric equivalents (to the nearest .01 mm) are given for general information only and are based upon 1 inch = 25.4 mm.
 - Metric equivalents are in parentheses.
 - Dimensions D, F, .498/.490 and .498 Ref. are taken at .102/.098 from top edge.
 - Dimensions E and G are taken at .052/.048 from flange.
 - For contact size #22, dimension A represents pin contacts and dimension C represents socket contacts.
 - The K diameter (S) includes the positional tolerance of the contact cavity plus the maximum amount of contact diameter splay.
 - It is not necessary for the shell to have stabilizing ribs providing D and F dimensions are maintained.

FIGURE 10. Quadruple plug connector intermateability control dimensions - Continued.
(Shell design - R A)

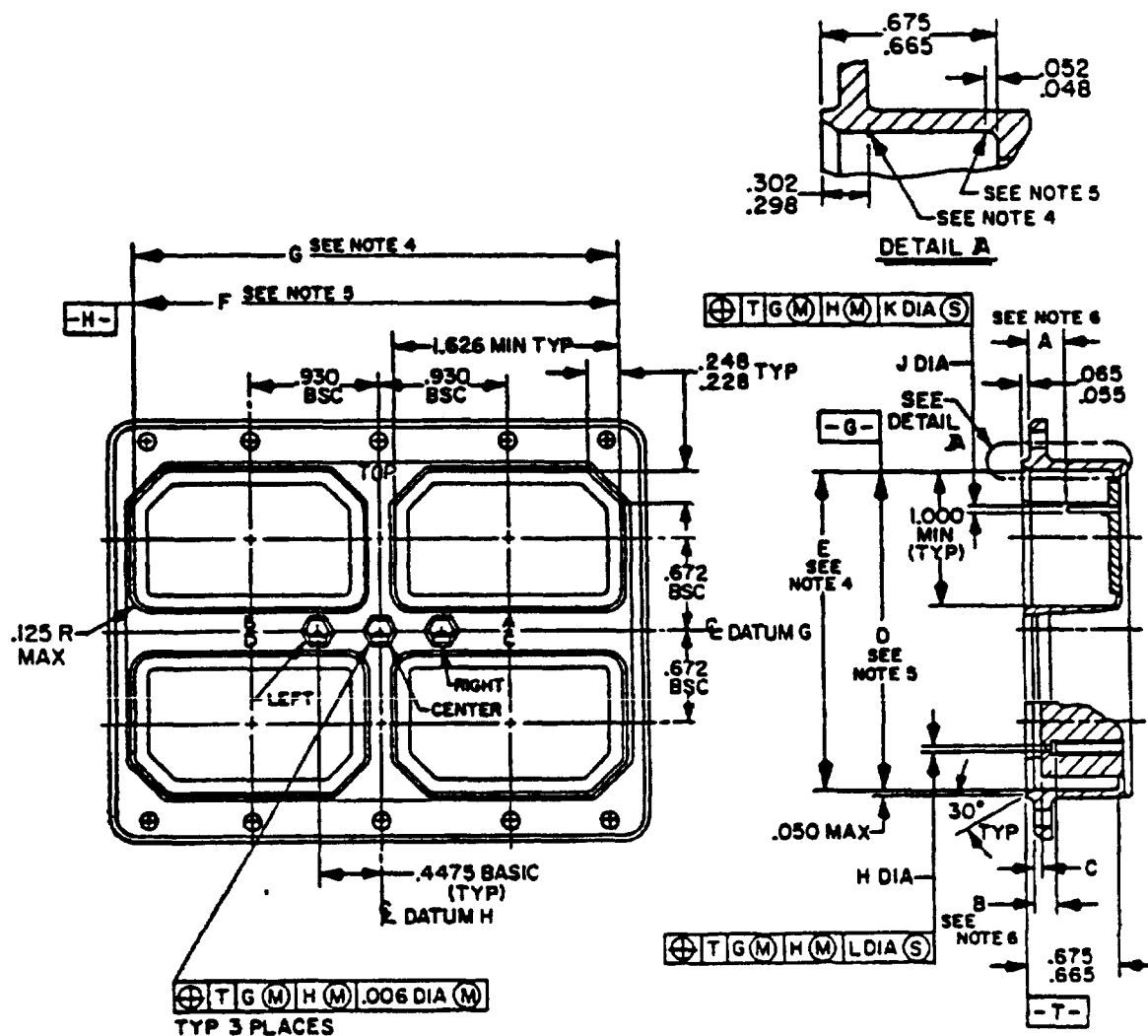

INCHES	MM	INCHES	MM	INCHES	MM	INCHES	MM	INCHES	MM
.006	.15	.055	1.40	.248	6.30	.665	16.89	.930	23.62
.048	1.22	.065	1.65	.298	7.57	.672	17.07	1.000	25.40
.050	1.27	.125	3.18	.302	7.67	.675	17.14	1.626	41.30
.052	1.32	.228	5.79	.4475	11.37				

FIGURE 11. Quadruple receptacle connector intermateability control dimensions.
(Shell designator A)

Connector	A				B				C				D	E	F	.6
	22	20	16	12	22	20	16	12	22	20	16	12				
	Series 1	.222 (5.64)	.355 (9.02)	.177 (4.50)		.193 (4.90)	.193 (4.90)	.193 (4.90)		.093 (2.36)	.093 (2.36)	.093 (2.36)				
Series 2	.155 (3.94)	.288 (7.32)	.110 (2.79)		.113 (2.87)	.113 (2.87)	.113 (2.87)		.053 (1.35)	.053 (1.35)	.053 (1.35)		2.345 (59.56)	2.350 (59.69)	3.492 (88.70)	3.497 (88.82)

Connector	H Dia (H)				J Dia (H)				K Dia (S)				L Dia (S)			
	22	20	16	12	22	20	16	12	22	20	16	12	22	20	16	12
	Series 1	.068 (1.73)	.122 (3.10)			.041 (1.04)	.0635 (1.61)	.095 (2.41)		.032 (.81)	.032 (.81)	.032 (.81)		.032 (.81)	.032 (.81)	.032 (.81)
Series 2	.063 (1.60)	.050 (1.27)	.068 (1.73)	.099 (2.51)	.061 (1.55)	.041 (1.04)	.095 (2.41)		.0095 (.24)	.040 (1.02)	.045 (1.14)	.061 (1.55)	.0075 (.19)	.010 (.25)	.015 (.38)	.020 (.51)

- NOTES
- Dimensions are in inches
 - Metric equivalents (to the nearest .01 mm) are given for general information only and are based upon 1 inch = 25.4 mm.
 - Metric equivalents are in parentheses.
 - Dimensions E and G are taken at .302/.298 from top edge.
 - Dimensions D and F are taken at .052/.048 from bottom of cavity.
 - For contact size #22, dimension A represents socket contacts and dimension B represents pin contacts
 - The K diameter (S) includes the positional tolerance of the contact cavity plus the maximum amount of contact diametral splay.

FIGURE 11 Quadruple receptacle connector Internateability control dimensions - Continued.
(Shell design A)

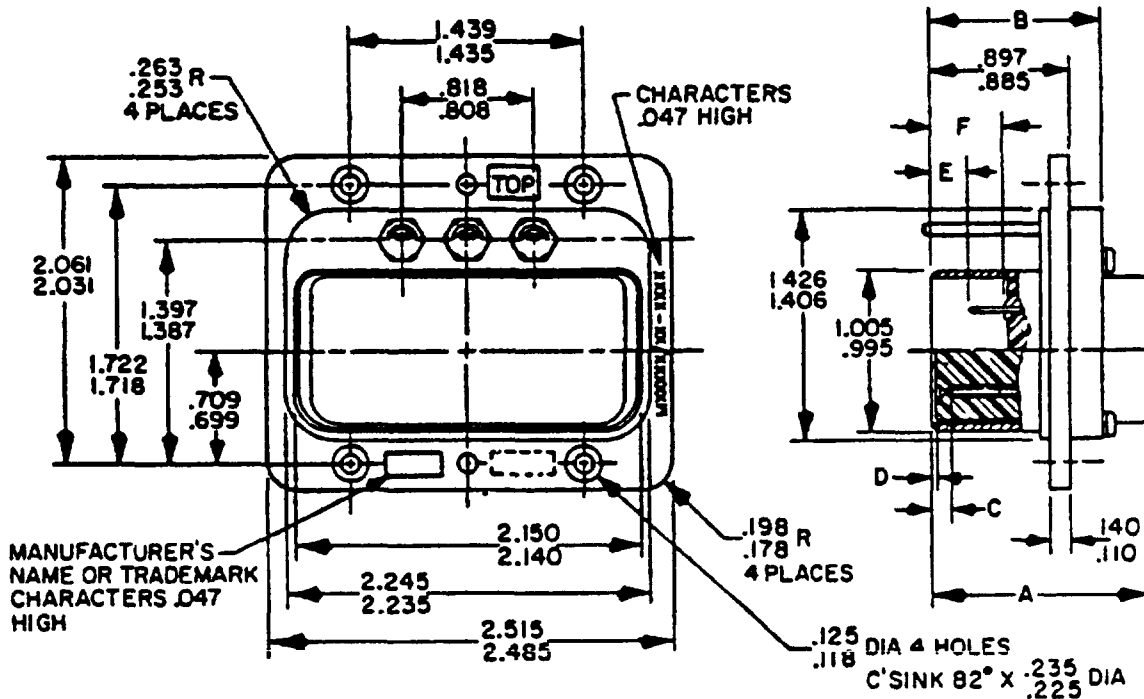

INCHES	MM	INCHES	MM	INCHES	MM	INCHES	MM	INCHES	MM
.047	1.19	.225	5.72	.818	20.78	1.406	35.71	2.061	52.35
.110	2.79	.235	5.97	.885	22.48	1.426	36.22	2.140	54.36
.118	3.00	.253	6.43	.897	22.78	1.435	36.45	2.150	54.61
.125	3.18	.263	6.68	.995	25.27	1.439	36.55	2.235	56.77
.140	3.56	.699	17.75	1.005	25.53	1.718	43.64	2.245	57.02
.178	4.52	.709	18.01	1.387	35.23	1.722	43.74	2.485	63.12
.198	5.03	.808	20.52	1.397	35.48	2.031	51.59	2.515	63.88

Connector	A Max	B Max	C			D			E			F		
			22	20	16	22	20	16	22	20	16	22	20	16
Series 1	1.625 (41.28)	1.200 (30.48)	---	.083 (2.11)	---	---	.045* (1.14)	---	---	.243 (6.17)	---	---	.489 (12.42)	---
				.015 (.38)			.017 (.43)			.194 (4.93)			.461 (11.71)	
Series 2	1.450 (36.83)	1.200 (30.48)	---	.108 (2.74)	---	---	.020 (.51)	---	---	.166 (4.22)	---	---	.473 (12.01)	---
				.072 (1.83)			.004 (.10)			.130 (3.30)			.443 (11.25)	

*This dimension extends from shell.

NOTES:

1. Dimensions are in inches.
2. Metric equivalents (to the nearest .01 mm) are given for general information only and are based upon 1 inch = 25.4 mm
3. Metric equivalents are in parentheses.

FIGURE 12. Single plug connector intermateability control dimensions.
(Shell designator B)

MIL-C-81659B

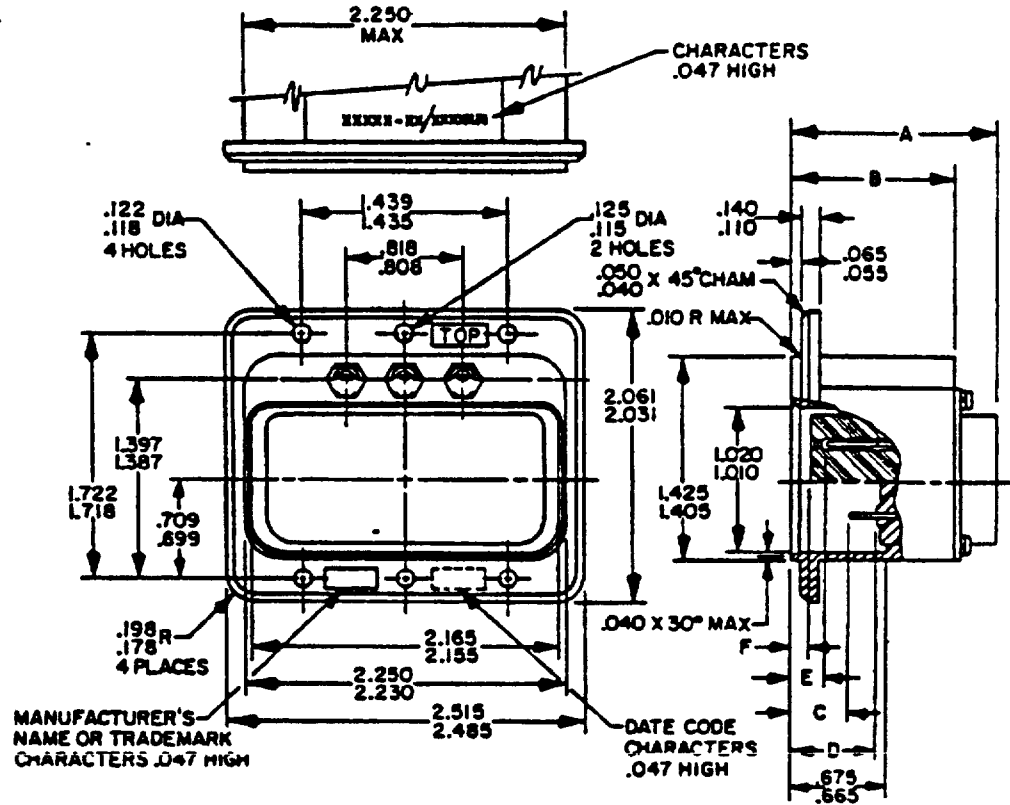

INCHES	MM	INCHES	MM	INCHES	MM	INCHES	MM	INCHES	MM
.010	.25	.118	3.00	.699	17.75	1.405	35.69	2.061	52.35
.040	1.02	.122	3.10	.709	18.01	1.425	36.20	2.155	54.74
.047	1.19	.125	3.18	.808	20.52	1.435	36.45	2.165	54.99
.050	1.27	.140	3.56	.818	20.78	1.439	36.55	2.230	56.64
.055	1.40	.178	4.52	1.010	25.65	1.718	43.64	2.250	57.15
.065	1.65	.198	5.03	1.020	25.91	1.722	43.74	2.485	63.12
.110	2.79	.665	16.89	1.387	35.23	2.031	51.59	2.515	63.88
.115	2.92	.675	17.14	1.397	35.48				

Connector	A Max	B Max	C			D			E			F		
			22	20	16	22	20	16	22	20	16	22	20	16
Series 1	1.812 (46.02)	1.300 (33.02)	---	410	---	---	.658	---	---	.248	---	---	.148	---
				(10.41)			(16.71)			(6.30)			(3.76)	
				.353 (8.97)			.620 (15.75)			.178 (4.52)			.118 (3.00)	
Series 2	1.475 (37.46)	1.300 (33.02)	---	345	---	---	.636	---	---	.287	---	---	.183	---
				(8.76)			(16.15)			(7.29)			(4.65)	
				.309 (7.85)			.606 (15.39)			.251 (6.38)			.168 (4.27)	

NOTES

- 1 Dimensions are in inches
- 2 Metric equivalents (to the nearest 01 mm) are given for general information only and are based upon 1 inch = 25.4 mm
- 3 Metric equivalents are in parentheses.

FIGURE 13 Single receptacle connector intermateability control dimensions (Shell designator B)

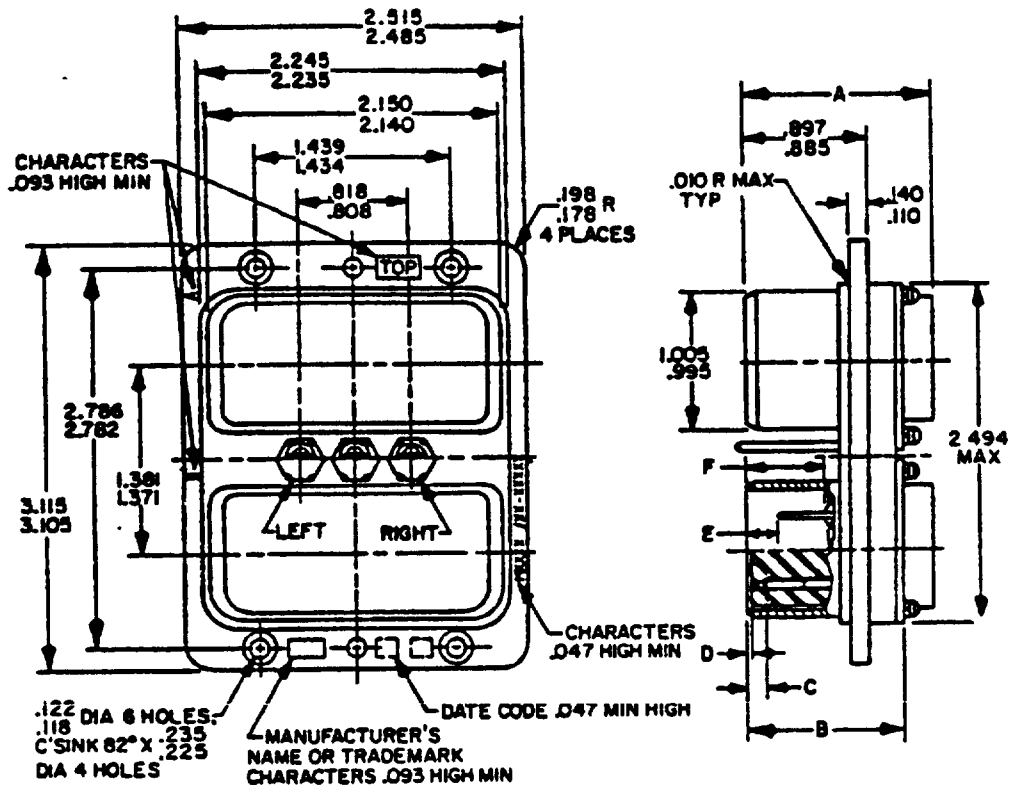

INCHES	MM	INCHES	MM	INCHES	MM	INCHES	MM	INCHES	MM
.010	.25	.178	4.52	.897	22.78	1.439	36.55	2.494	63.35
.047	1.19	.198	5.03	.995	25.27	2.140	54.36	2.515	63.88
.093	2.36	.225	5.72	1.005	25.53	2.150	54.61	2.782	70.66
.110	2.79	.235	5.97	1.371	34.82	2.235	56.77	2.786	70.76
.118	3.00	.808	20.52	1.381	35.08	2.245	57.02	3.105	78.87
.122	3.10	.818	20.78	1.434	36.42	2.485	63.12	3.115	79.12
.140	3.56	.885	22.48						

Connector	A Max	B Max	C			D			E			F		
			22	20	16	22	20	16	22	20	16	22	20	16
Series 1	1.625 (41.28)	1.200 (30.48)	---	.083 (2.11)	---	---	.045* (1.14)	---	---	.243 (6.17)	---	---	.489 (12.42)	---
				.015 (.38)			.017 (.43)			.194 (4.93)			.461 (11.71)	
Series 2	1.450 (36.83)	1.200 (30.48)	---	.108 (2.74)	---	---	.020 (.51)	---	---	.166 (4.22)	---	---	.473 (12.01)	---
				.072 (1.83)			.004 (.10)			.130 (3.30)			.443 (11.25)	

*This dimension extends from shell.

NOTES:

1. Dimensions are in inches.
2. Metric equivalents (to the nearest .01 mm) are given for general information only and are based upon 1 inch = 25.4 mm.
3. Metric equivalents are in parentheses.

FIGURE 14. Dual plug connector intermateability control dimensions.
(Shell designator B)

MIL-C-81659B

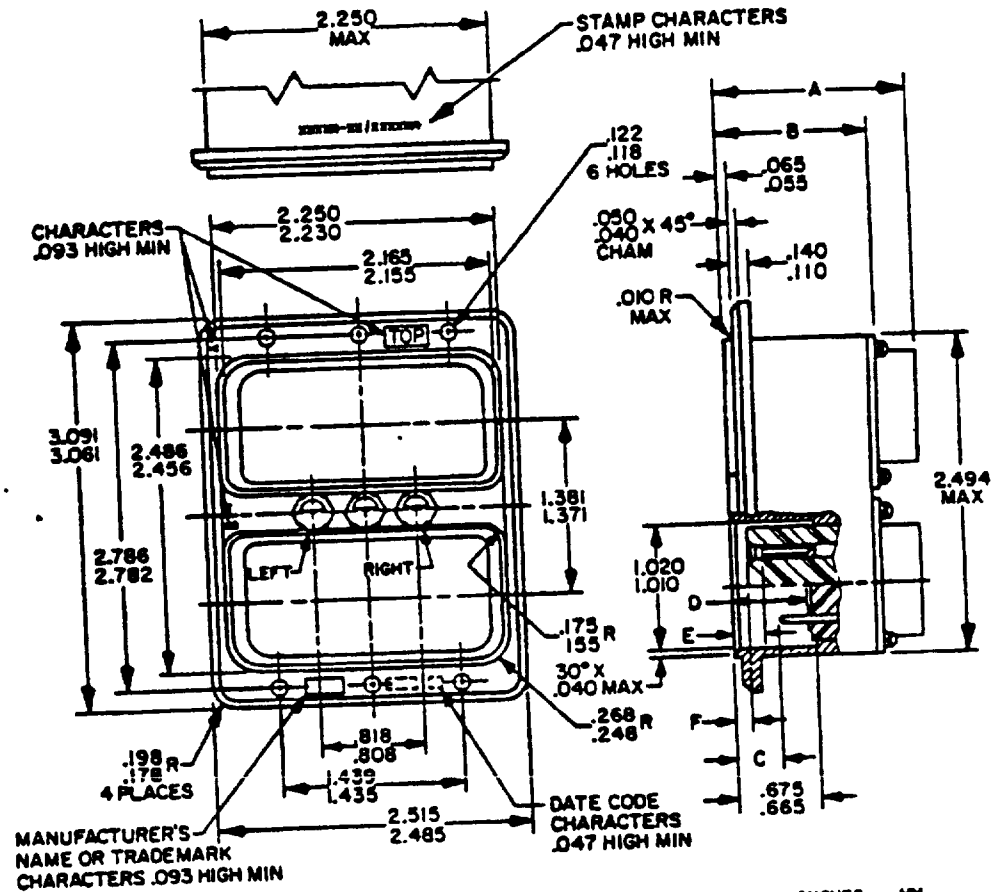

INCHES	MM	INCHES	MM	INCHES	MM	INCHES	MM	INCHES	MM
.010	.25	.118	3.00	.268	6.81	1.381	35.08	2.485	63.12
.040	1.02	.122	3.10	.665	16.89	1.435	36.45	2.486	63.14
.047	1.19	.140	3.56	.675	17.14	1.439	36.55	2.494	63.35
.050	1.27	.155	3.94	.808	20.52	2.155	54.74	2.515	63.88
.055	1.40	.175	4.44	.818	20.78	2.165	54.99	2.782	70.66
.065	1.65	.178	4.52	1.010	25.65	2.230	56.64	2.786	70.76
.093	2.36	.198	5.03	1.020	25.91	2.250	57.15	3.061	77.75
.110	2.79	.248	6.30	1.371	34.82	2.456	62.38	3.091	78.51

Connector	A Max	B Max	C			D			E			F		
			22	20	16	22	20	16	22	20	16	22	20	16
Series 1	1.812 (46.02)	1.300 (33.02)	---	.410 (10.41)	---	---	.658 (16.71)	---	---	.248 (6.30)	---	---	.148 (3.76)	---
			---	.353 (8.97)	---	---	.620 (15.75)	---	---	.178 (4.52)	---	---	.118 (3.00)	---
			---	.345 (8.76)	---	---	.636 (16.15)	---	---	.287 (7.29)	---	---	.183 (4.65)	---
Series 2	1.475 (37.46)	1.300 (33.02)	---	.309 (7.85)	---	---	.606 (15.39)	---	---	.251 (6.38)	---	---	.168 (4.27)	---
			---	---	---	---	---	---	---	---	---	---	---	---

NOTES:

- Dimensions are in inches.
- Metric equivalents (to the nearest 01 mm) are given for general information only and are based upon 1 inch = 25.4 mm.
- Metric equivalents are in parentheses

FIGURE 15. Dual receptacle connector intermateability control dimensions (Shell designator B)

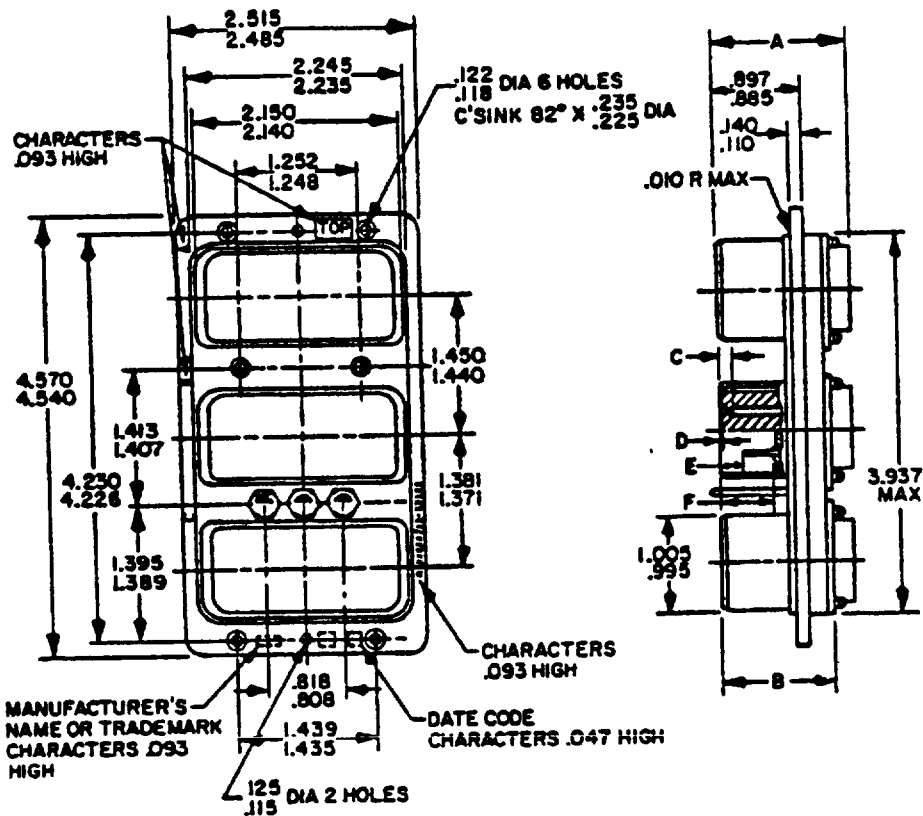

INCHES	MM	INCHES	MM	INCHES	MM	INCHES	MM	INCHES	MM
.010	.25	.225	5.72	1.248	31.70	1.435	36.45	2.485	63.12
.093	2.36	.235	5.97	1.252	31.80	1.439	36.55	2.515	63.88
.110	2.79	.808	20.52	1.371	34.82	1.440	36.58	3.937	100.00
.115	2.92	.818	20.78	1.381	35.08	1.450	36.83	4.226	107.34
.118	3.00	.885	22.48	1.389	35.28	2.140	54.36	4.230	107.44
.122	3.10	.897	22.78	1.395	35.43	2.150	54.61	4.540	115.32
.125	3.18	.995	25.27	1.407	35.74	2.235	56.77	4.570	116.08
.140	3.56	1.005	25.53	1.413	35.89	2.245	57.02		

Connector	A Max	B Max	C			D			E			F		
			22	20	16	22	20	16	22	20	16	22	20	16
Series 1	1.625 (41.28)	1.200 (30.48)	---	.083 (2.11)	---	---	.045* (1.14)	---	---	.243 (6.17)	---	---	.489 (12.42)	---
				.015 (.38)			.017 (.43)			.194 (4.93)			.461 (11.71)	
Series 2	1.450 (36.83)	1.200 (30.48)	---	.108 (2.74)	---	---	.020 (.51)	---	---	.166 (4.22)	---	---	.473 (12.01)	---
				.072 (1.83)			.004 (.10)			.130 (3.30)			.443 (11.25)	

*This dimension extends from shell.

NOTES:

- Dimensions are in inches.
- Metric equivalents (to the nearest .01 mm) are given for general information only and are based upon 1 inch = 25.4 mm.
- Metric equivalents are in parentheses.

FIGURE 16. Triple plug connector intermateability control dimensions (Shell designator B)

MIL-C-81659B

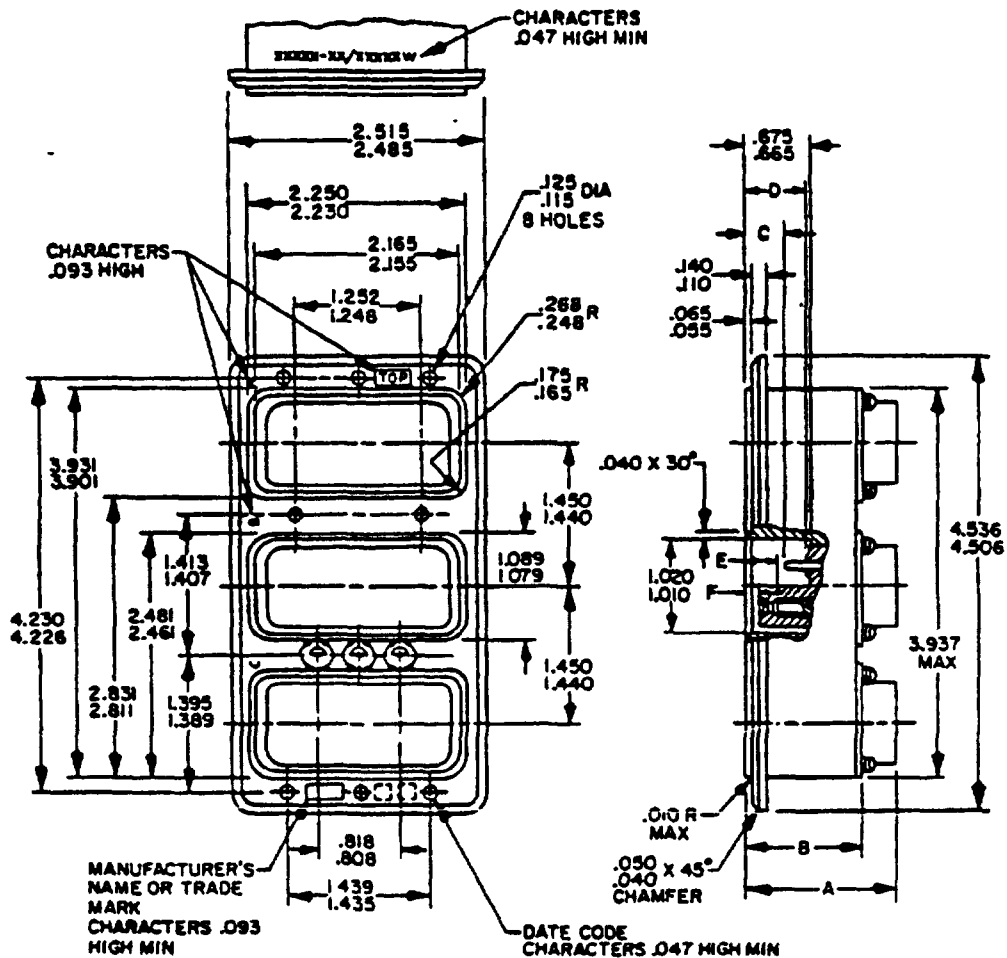

INCHES	MM	INCHES	MM	INCHES	MM	INCHES	MM	INCHES	MM
.010	.25	.140	3.56	1.020	25.91	1.439	36.55	2.515	63.88
.040	1.02	.165	4.19	1.079	27.41	1.440	36.58	2.811	71.40
.047	1.19	.175	4.44	1.089	27.66	1.450	36.83	2.831	71.91
.050	1.27	.248	6.30	1.248	31.70	2.155	54.74	3.901	99.08
.055	1.40	.268	6.81	1.252	31.80	2.165	54.99	3.931	99.85
.065	1.65	.665	16.89	1.385	35.18	2.230	56.64	3.937	100.00
.093	2.36	.675	17.14	1.395	35.43	2.250	57.15	4.226	107.34
.110	2.79	.808	20.52	1.407	35.74	2.461	62.51	4.230	107.44
.115	2.92	.818	20.78	1.413	35.89	2.481	63.02	4.506	114.45
.125	3.18	1.010	25.65	1.435	36.45	2.485	63.12	4.536	115.21

Connector	A Max	B Max	C			D			E			F		
			22	20	16	22	20	16	22	20	16	22	20	16
Series 1	1.812 (46.02)	1.300 (33.02)	---	.410 (10.41)	---	---	.658 (16.71)	---	---	.248 (6.30)	---	---	.148 (3.76)	---
			---	.353 (8.97)	---	---	.620 (15.75)	---	---	.178 (4.52)	---	---	.118 (3.00)	---
Series 2	1.475 (37.46)	1.300 (33.02)	---	.345 (8.76)	---	---	.636 (16.15)	---	---	.287 (7.29)	---	---	.183 (4.65)	---
			---	.309 (7.85)	---	---	.606 (15.39)	---	---	.251 (6.38)	---	---	.168 (4.27)	---

NOTES.

1. Dimensions are in inches.
2. Metric equivalents (to the nearest .01 mm) are given for general information only and are based upon 1 inch = 25.4 mm.
3. Metric equivalents * are in parentheses.

FIGURE 17 Triple receptacle connector intermateability control dimensions.
(Shell designator B)

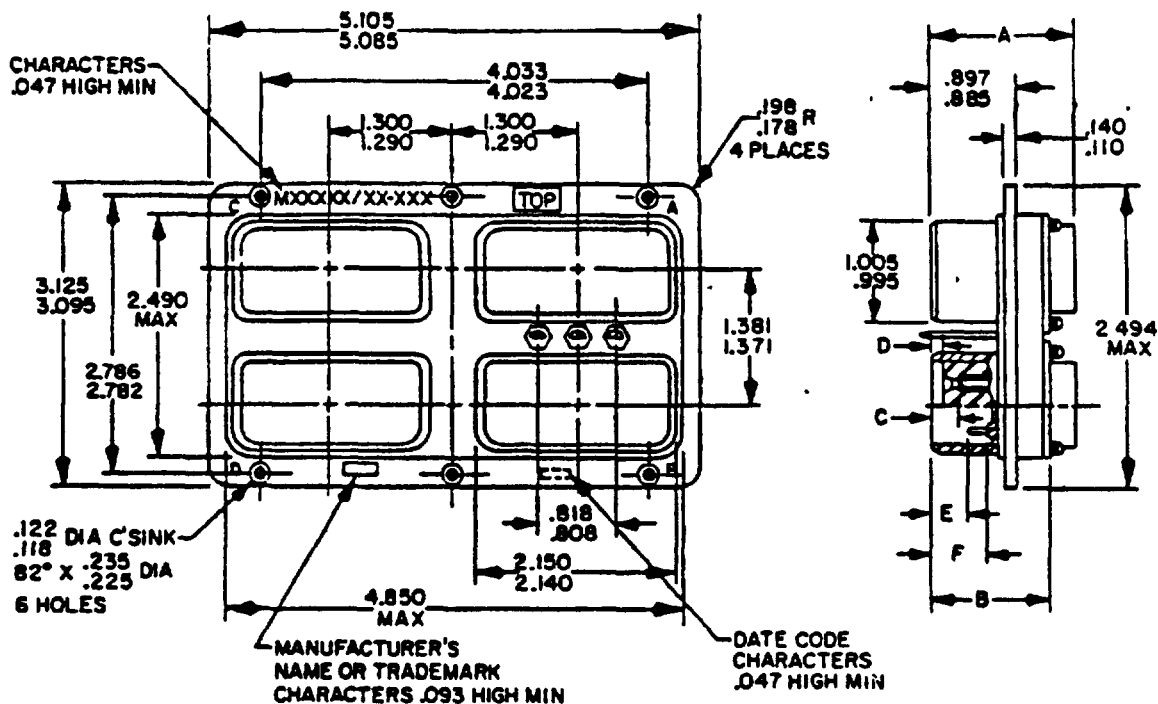

INCHES	MM	INCHES	MM	INCHES	MM	INCHES	MM	INCHES	MM
.047	1.19	.198	5.03	.897	22.78	1.381	35.08	3.095	78.61
.110	2.79	.225	5.72	.995	25.27	2.140	54.36	3.125	79.38
.118	3.00	.235	5.97	1.005	25.53	2.150	54.61	4.023	102.44
.122	3.10	.235	5.97	1.290	32.77	2.490	63.25	4.033	102.44
.140	3.56	.818	20.52	1.300	33.02	2.494	63.35	4.850	123.19
.178	4.52	.885	22.48	1.371	34.82	2.782	70.66	5.085	129.16
						2.786	70.76	5.105	129.67

Connector	A Max	B Max	C			D			E			F		
			22	20	16	22	20	16	22	20	16	22	20	16
Series 1	1.625 (41.28)	1.200 (30.48)	---	.083 (2.11)	---	---	.045* (1.14)	---	---	.243 (6.17)	---	---	489 (12.42)	---
				.015 (.38)			.017 (.43)			.194 (4.93)			.461 (11.71)	
Series 2	1.450 (36.83)	1.200 (30.48)	---	.108 (2.74)	---	---	.020 (.51)	---	---	.166 (4.22)	---	---	473 (12.01)	---
				.072 (1.83)			.004 (.10)			.130 (3.30)			443 (11.25)	

*This dimension extends from shell.

NOTES:

1. Dimensions are in inches.
2. Metric equivalents (to the nearest .01 mm) are given for general information only and are based upon 1 inch = 25.4 mm.
3. Metric equivalents are in parentheses.

FIGURE 18 Quadruple plug connector intermateability control dimensions
(Shell designator B)

MIL-C-81659B

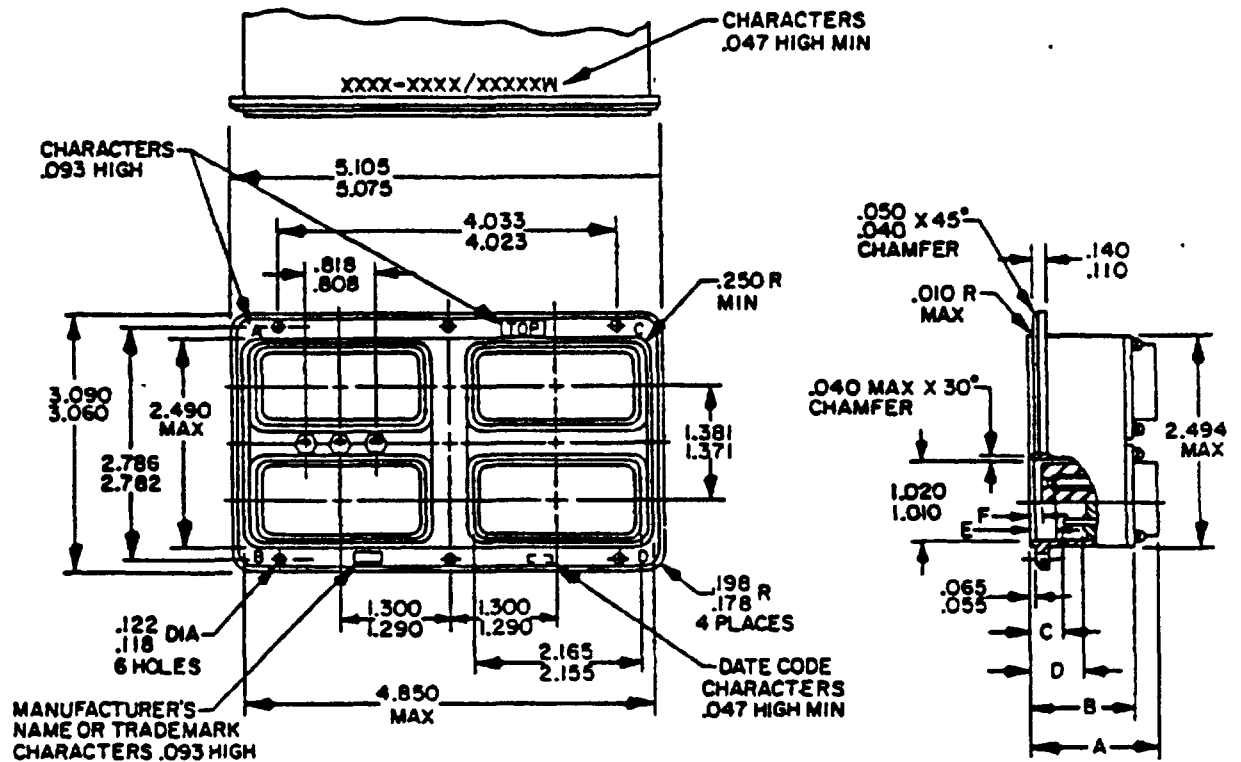

INCHES	MM	INCHES	MM	INCHES	MM	INCHES	MM	INCHES	MM
.010	.25	.110	2.79	.808	20.52	1.381	35.08	3.060	77.72
.040	1.02	.118	3.00	.818	20.78	2.155	54.74	3.090	78.49
.047	1.19	.122	3.10	1.010	25.65	2.165	54.99	4.023	102.18
.050	1.27	.140	3.56	1.020	25.91	2.490	63.25	4.033	102.44
.055	1.40	.178	4.52	1.290	32.77	2.494	63.35	4.850	123.19
.065	1.65	.198	5.03	1.300	33.02	2.782	70.66	5.075	128.90
.093	2.36	.250	6.35	1.371	34.82	2.786	70.76	5.105	129.67

Connector	A Max	B Max	C			D			E			F		
			22	20	16	22	20	16	22	20	16	22	20	16
Series 1	1.812 (46.02)	1.300 (33.02)	---	.410 (10.41)	---	---	.658 (16.71)	---	---	.248 (6.30)	---	---	.148 (3.76)	---
				.353 (8.97)			.620 (15.75)			.178 (4.52)			.118 (3.00)	
Series 2	1.475 (37.46)	1.300 (33.02)	---	.345 (8.76)	---	---	.636 (16.15)	---	---	.287 (7.29)	---	---	.183 (4.65)	---
				.309 (7.85)			.606 (15.39)			.251 (6.38)			.168 (4.27)	

NOTES:

- Dimensions are in inches.
- Metric equivalents (to the nearest 01 mm) are given for general information only and are based upon 1 inch = 25.4 mm.
- Metric equivalents are in parentheses.

FIGURE 19. Quadruple receptacle connector intermateability control dimensions
(Shell designator B)

FOLD

Naval Air Engineering Center
Lakehurst, NJ 08733

POSTAGE AND FEES PAID

DoD 316



OFFICIAL BUSINESS
PENALTY FOR PRIVATE USE \$300

Commanding Officer
Naval Air Engineering Center
ATTN: ESSD Code 9313
Lakehurst, NJ 08733

FOLD

STANDARDIZATION DOCUMENT IMPROVEMENT PROPOSAL		OMB Approval No. 22-R255	
<p>INSTRUCTIONS. The purpose of this form is to solicit beneficial comments which will help achieve procurement of suitable products at reasonable cost and minimum delay, or will otherwise enhance use of the document. DoD contractors, government activities, or manufacturers/vendors who are prospective suppliers of the product are invited to submit comments to the government. Fold on lines on reverse side, staple in corner, and send to preparing activity. Comments submitted on this form do not constitute or imply authorization to waive any portion of the referenced document(s) or to amend contractual requirements. Attach any pertinent data which may be of use in improving this document. If there are additional papers, attach to form and place both in an envelope addressed to preparing activity.</p>			
DOCUMENT IDENTIFIER AND TITLE			
NAME OF ORGANIZATION AND ADDRESS		CONTRACT NUMBER	
		MATERIAL PROCURED UNDER A	
		<input type="checkbox"/> DIRECT GOVERNMENT CONTRACT <input type="checkbox"/> SUBCONTRACT	
<p>1. HAS ANY PART OF THE DOCUMENT CREATED PROBLEMS OR REQUIRED INTERPRETATION IN PROCUREMENT USE? A. GIVE PARAGRAPH NUMBER AND WORDING.</p> <p>B. RECOMMENDATIONS FOR CORRECTING THE DEFICIENCIES</p>			
2. COMMENTS ON ANY DOCUMENT REQUIREMENT CONSIDERED TOO RIGID			
<p>3 IS THE DOCUMENT RESTRICTIVE? <input type="checkbox"/> YES <input type="checkbox"/> NO (If "Yes", in what way?)</p>			
4 REMARKS			
SUBMITTED BY <i>(Printed or typed name and address - Optional)</i>		TELEPHONE NO	
		DATE	

DD FORM 1426
1 JAN 72

REPLACES EDITION OF 1 JAN 66 WHICH MAY BE USED

S/N 0102-014-1802