

| INCH- POUND |

MIL-C-52950A
 AMENDMENT 2
27 November 1991
 SUPERSEDING
 AMENDMENT 1
 18 September 1991

MILITARY SPECIFICATION

CRATES, WOOD, OPEN AND COVERED

This amendment forms a part of Military Specification MIL-C-52950A, dated 20 March 1991, and is approved for use by all Departments and Agencies of the Department of Defense.

PAGE 1

- * Change document identifier to read as follows:

| INCH- POUND |

MIL-C-52950A
20 March 1991
 SUPERSEDING
 MIL-C-52950
 10 April 1978

PAGE 2

- * Table I, above first column and to left of "load" add "Type."

Table I, delete last row of numbers (Type V), and replace with the following:

| | | | | | | | | |
|------|------|----|---|---|------|----|---|----|
| V 2/ | 2500 | 12 | 6 | 6 | 4000 | 32 | 6 | 10 |
|------|------|----|---|---|------|----|---|----|

PAGE 22

Project number: Delete "PACK-0793" and substitute "8115-0513."

Under "User Activities" delete "MU" and insert "AR."

MIL-C-52950A
AMENDMENT 2

PAGE 23 THRU PAGE 40

Add figures 1 thru 18.

The margins of this amendment are marked with an asterisk or vertical lines to indicate where changes (additions, modifications, corrections, deletions) from the previous amendment were made. This was done as a convenience only and the Government assumes no liability whatsoever for any inaccuracies in these notations. Bidders and contractors are cautioned to evaluate the requirements of this document based on the entire content irrespective of the marginal notations and relationship to the last previous amendment.

Custodians:

Army - ME
Navy - YD
Air Force - 69

Preparing Activity:

Navy - YD

(Project 8115-0533)

Review Activities:

Army - CR, SM, GL, EA
Navy - SA

User Activities:

Army - AR, AT
Navy - MC

MIL-C-52950A

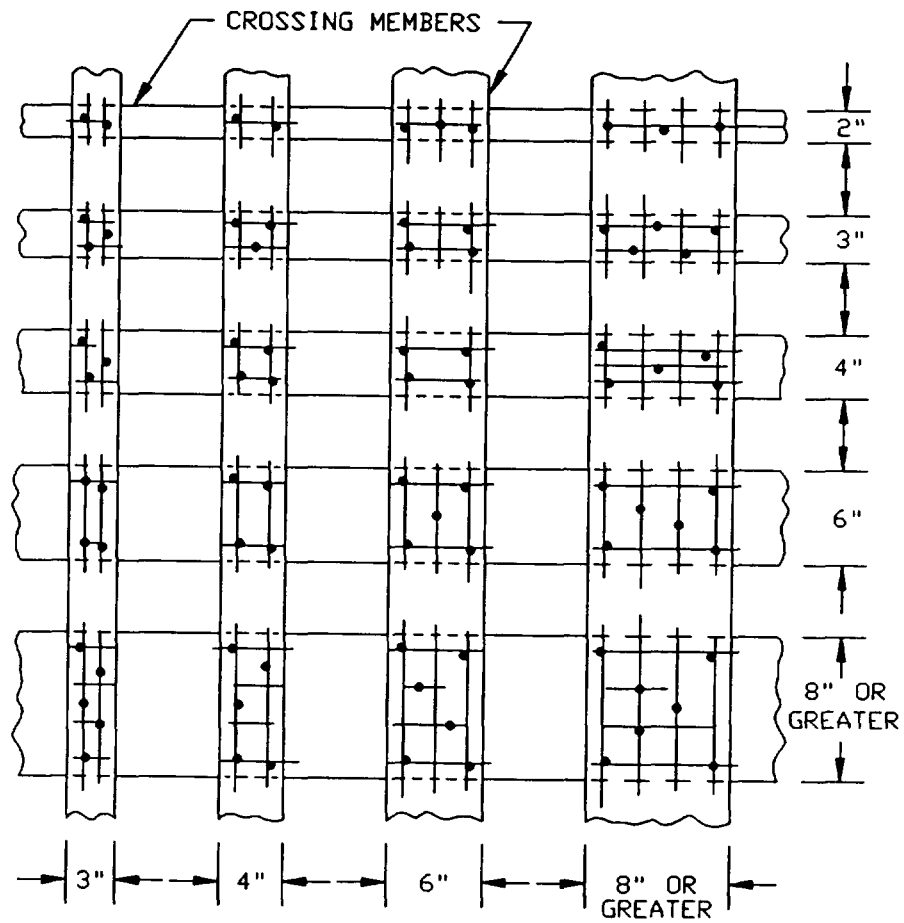
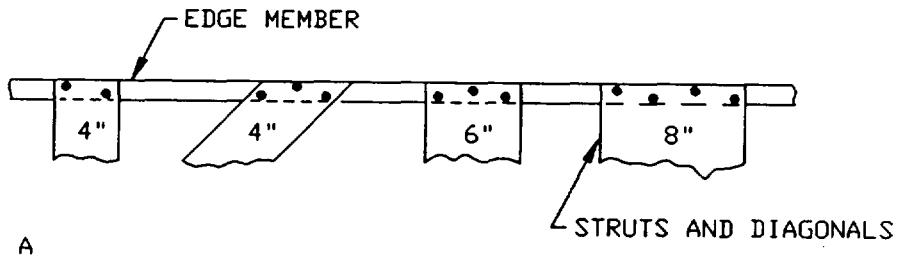

FIGURE 1. Nailing patterns. (All widths are nominal. Similar patterns shall be used when boards cross at angles other 90°.)

MIL-C-52950A

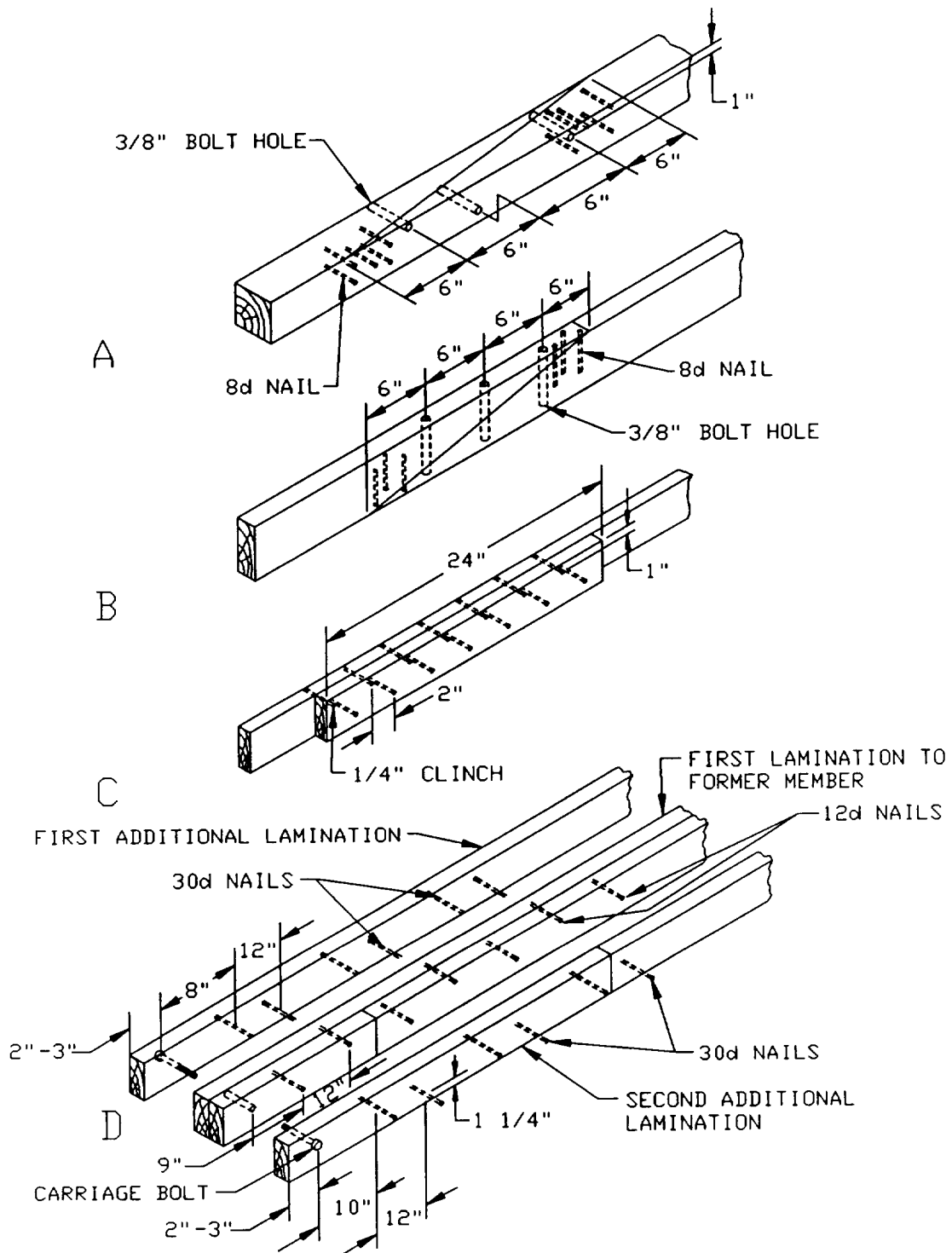

FIGURE 2. Splicing of members; A, splice of 4-by-4 inch or 4-by-6 inch skids; B, splice of 2-inch member; C, splice of 1-inch member; D, lamination of skid.

MIL-C-52950A

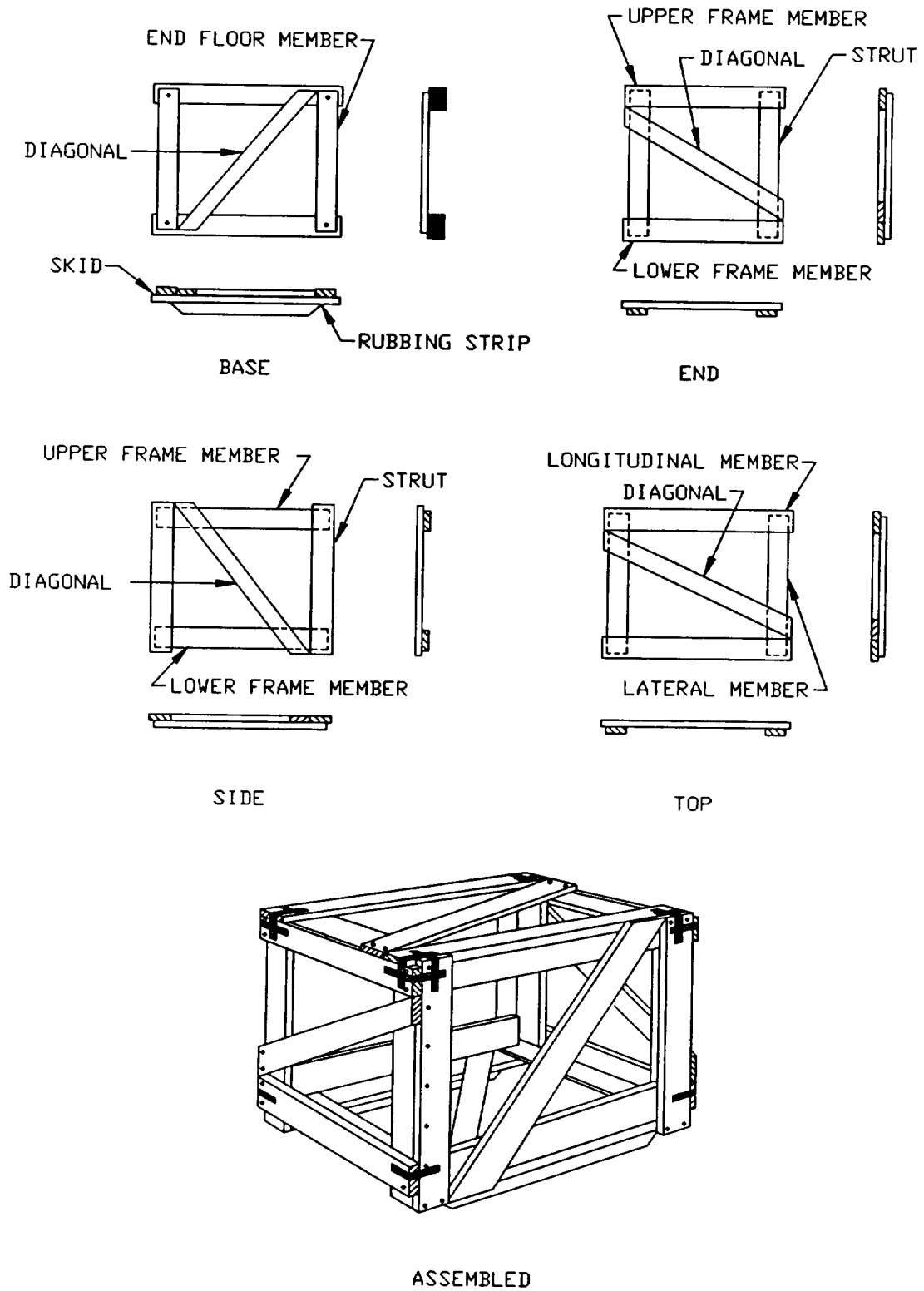

FIGURE 3. Type I, style A crate assembly.

MIL-C-52950A

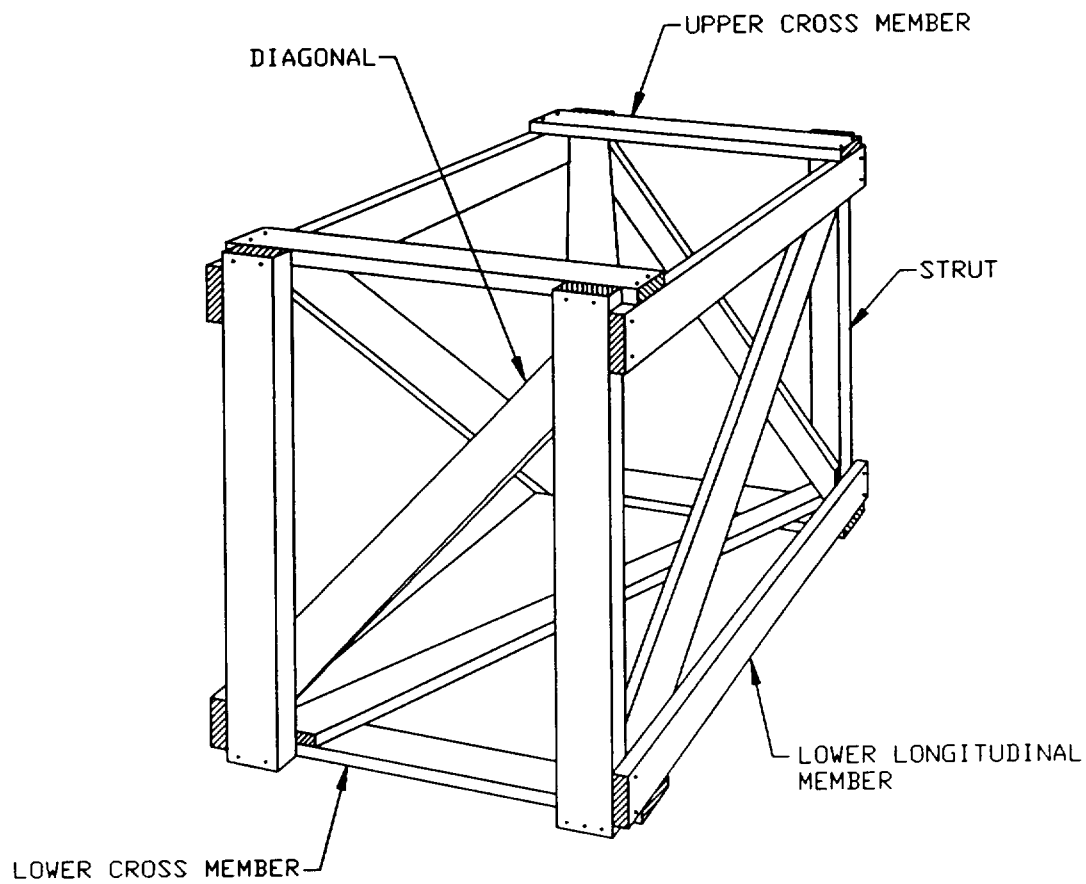

FIGURE 4. Type I, style B crate assembly.

MIL-C-52950A

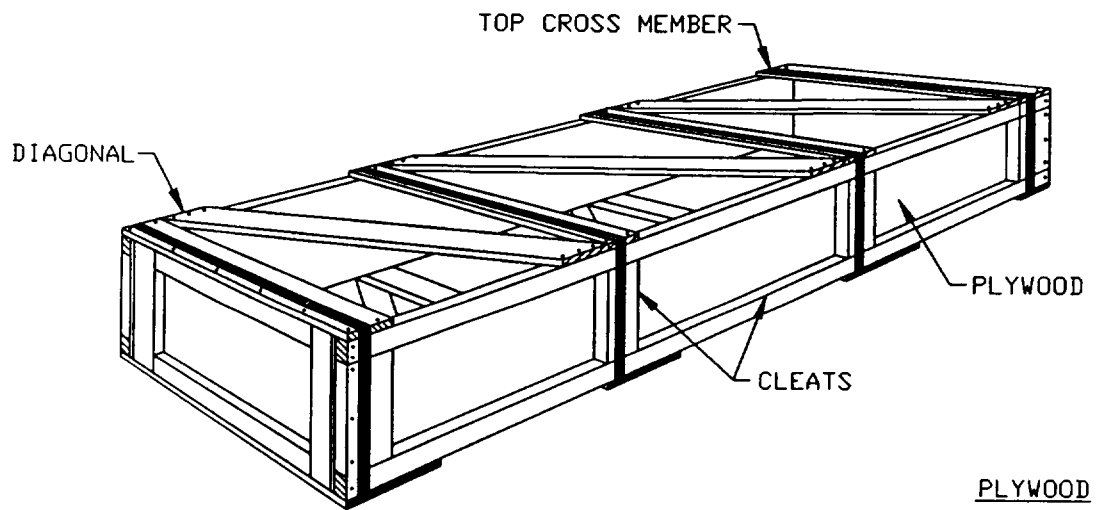
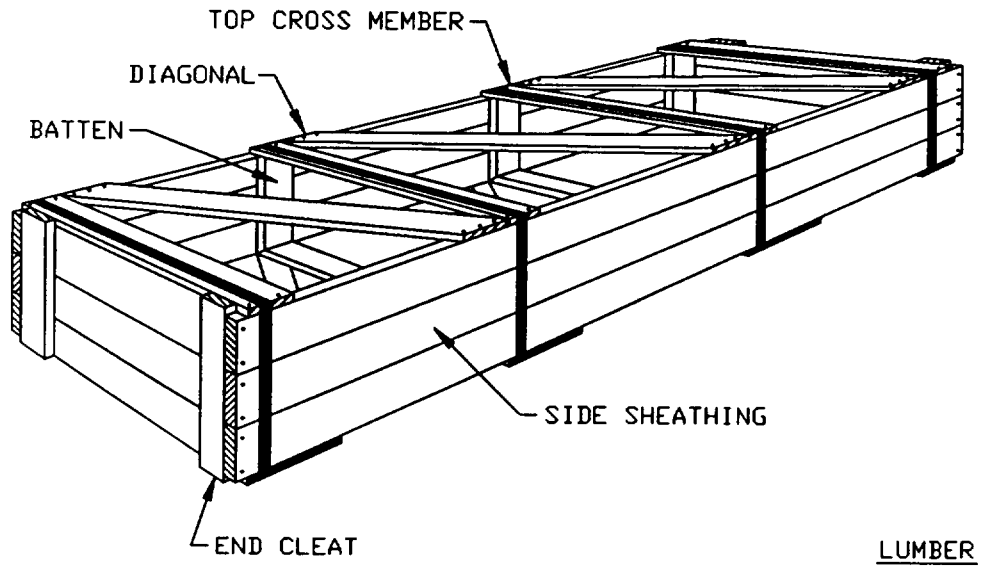
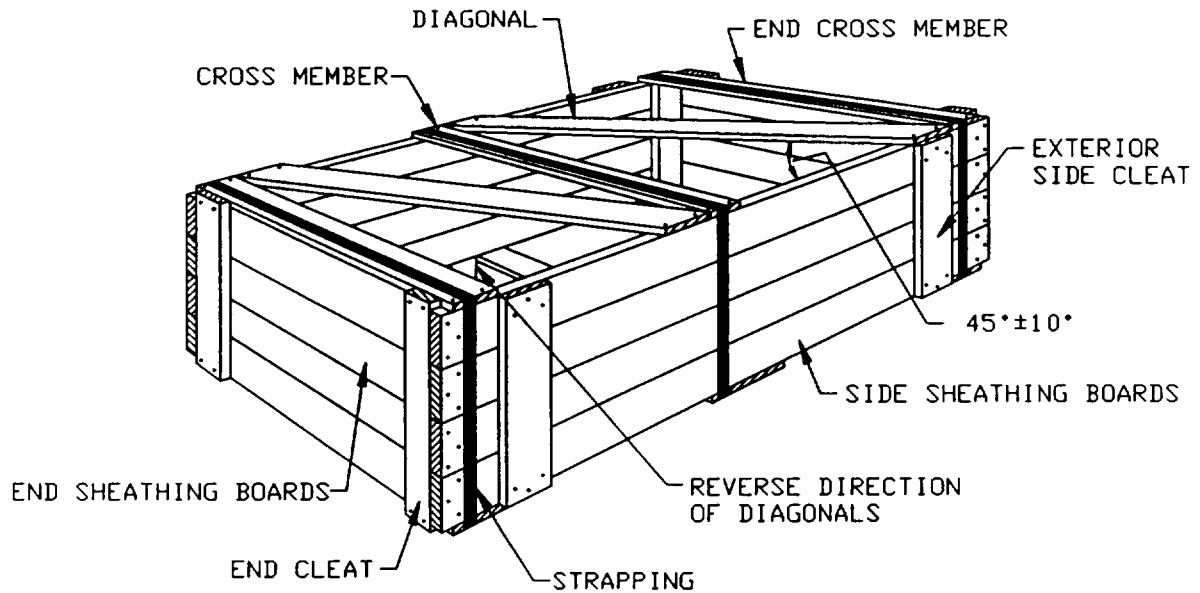
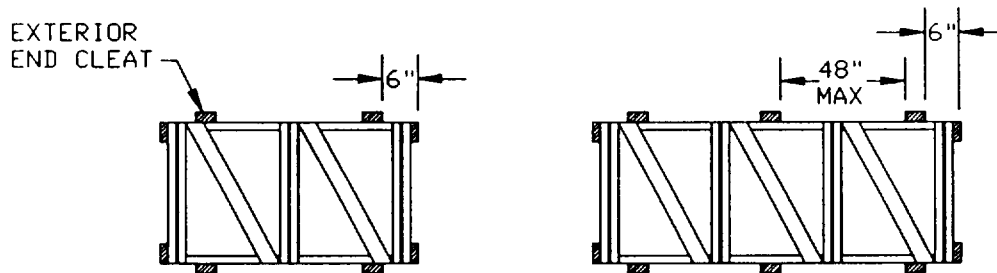

FIGURE 5. Type II, style A, crate assembly.

MIL-C-52950A



A



B

C

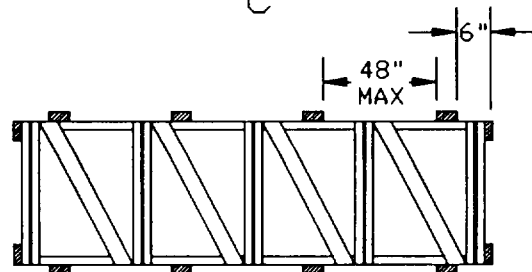

D

FIGURE 6. Type II, crate with exterior side cleats:
A, complete crate; B, two panel; C, three panel;
and D, four panel.

MIL-C-52950A

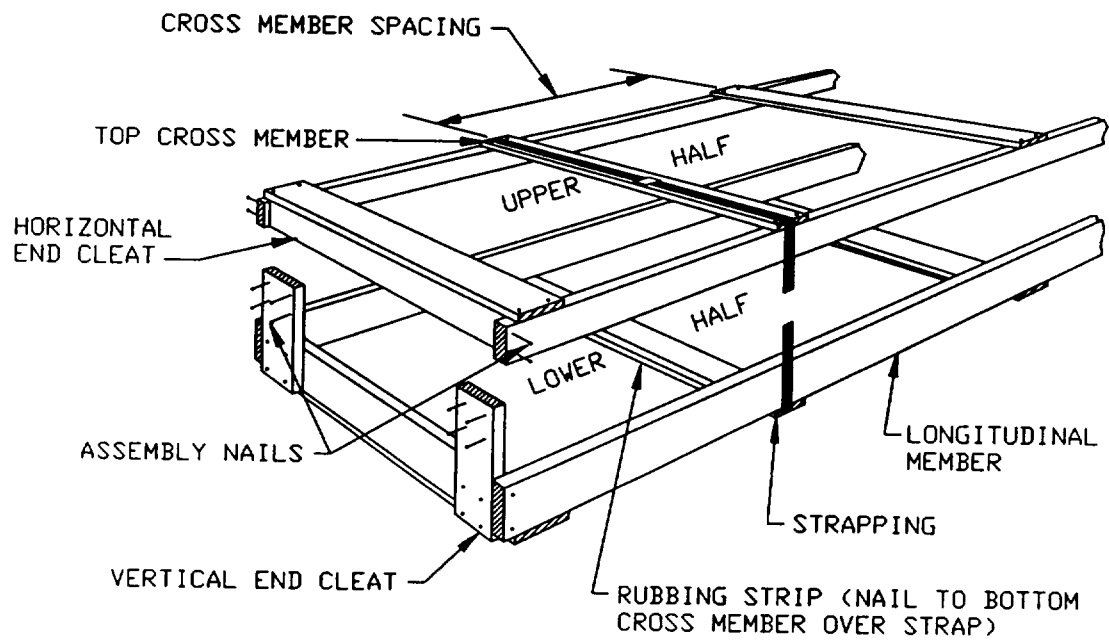

FIGURE 7. Type III, style B, crate assembly.

MIL-C-52950A

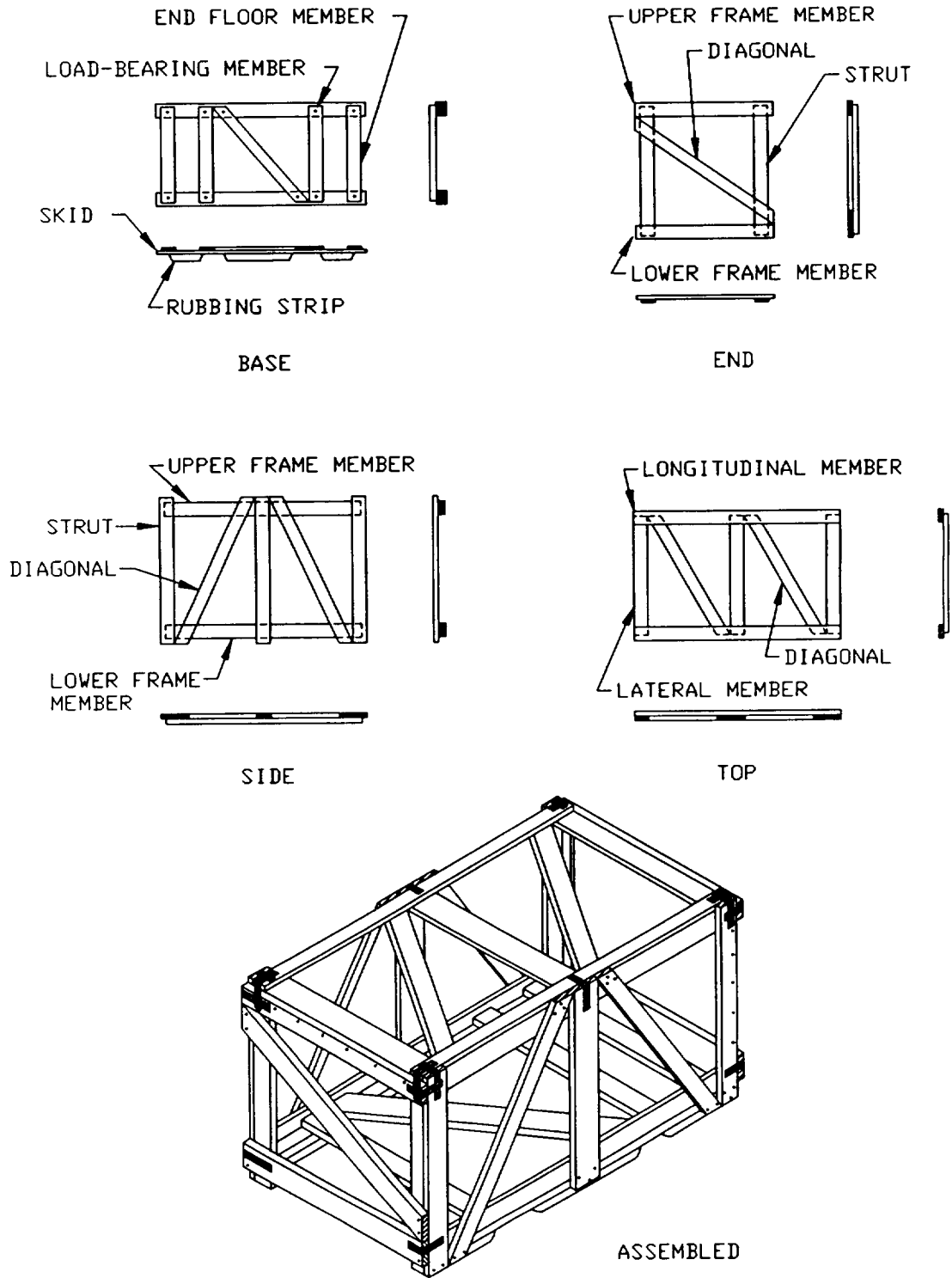

FIGURE 8. Type IV, style A crate assembly.

MIL-C-52950A

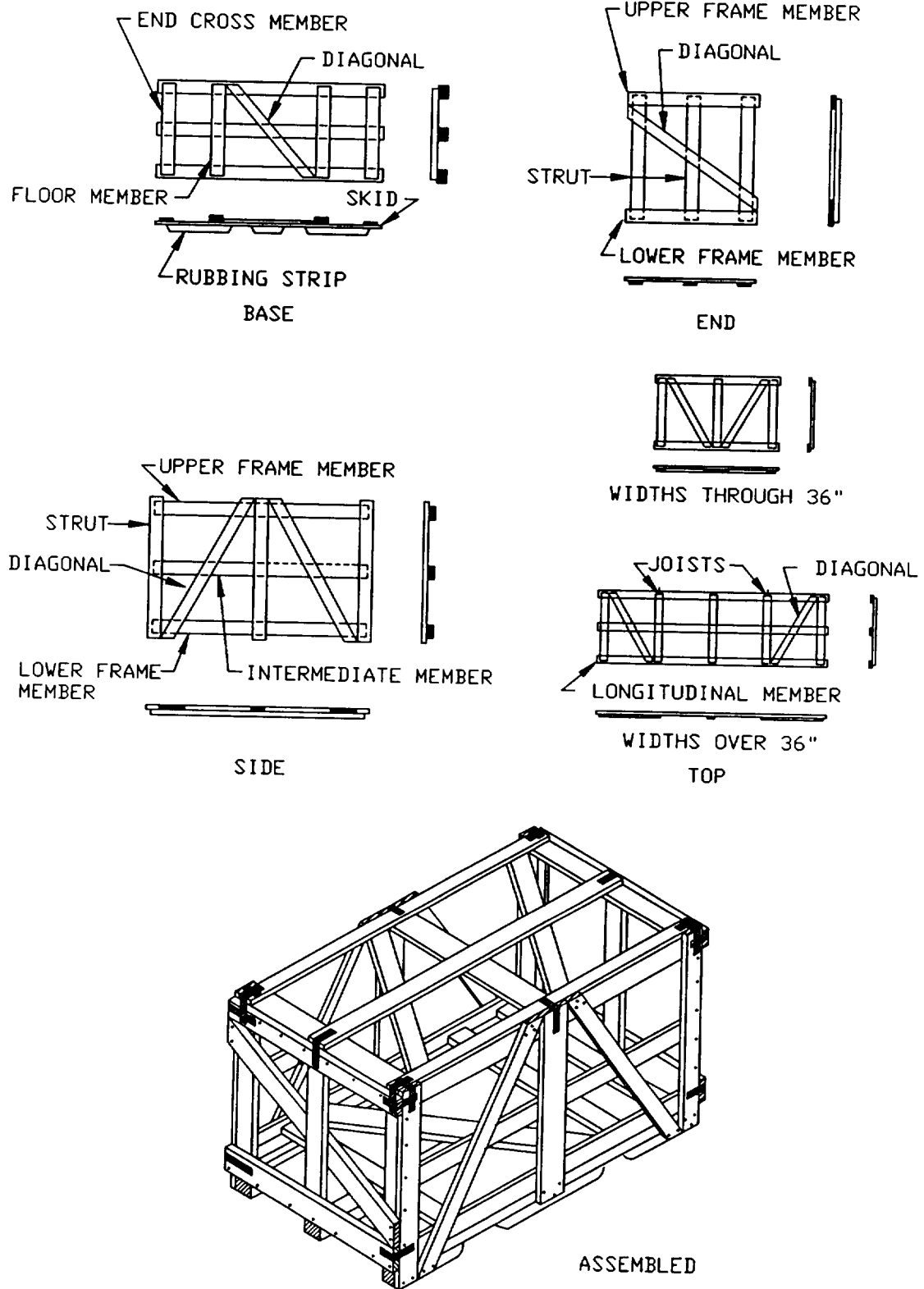
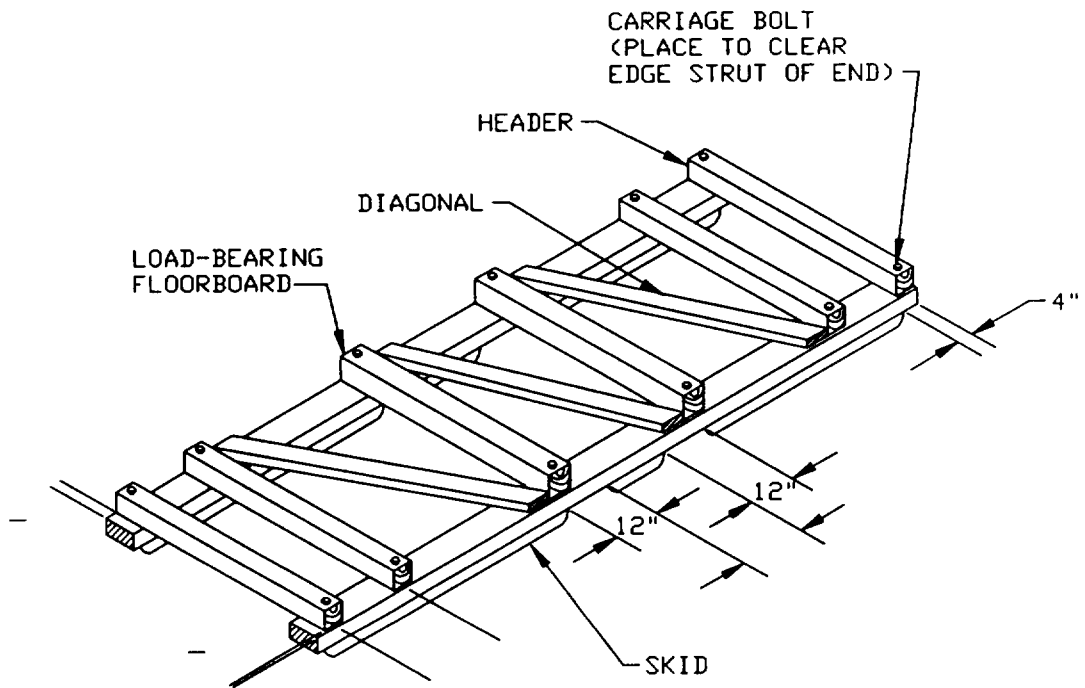
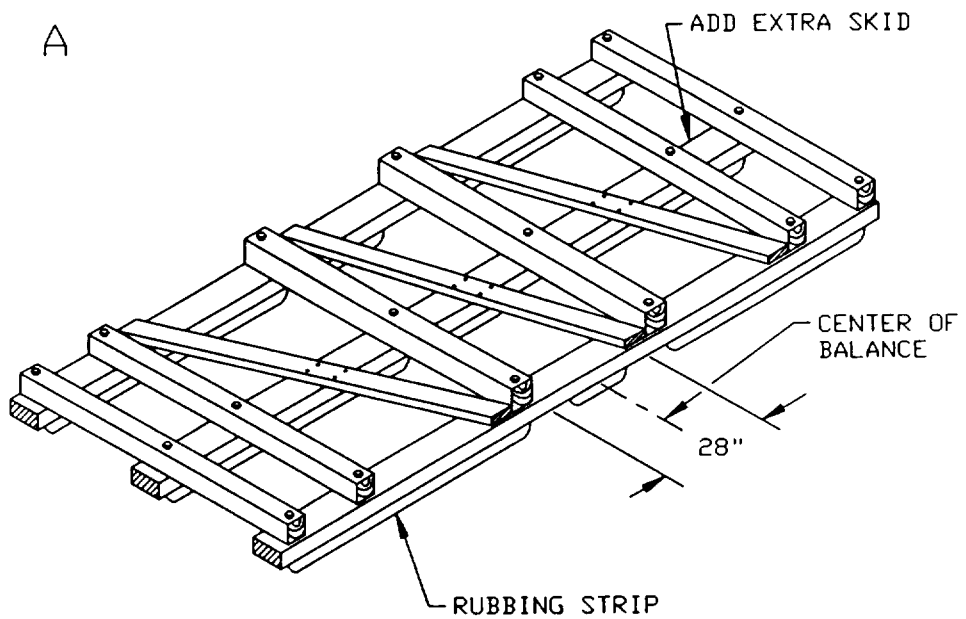

FIGURE 9. Type V, style A crate assembly.

MIL-C-52950A



A



B

FIGURE 10. Bases for type V, style B crates:
A, up through 42 inches wide;
B, over 42 inches wide.

MIL-C-52950A

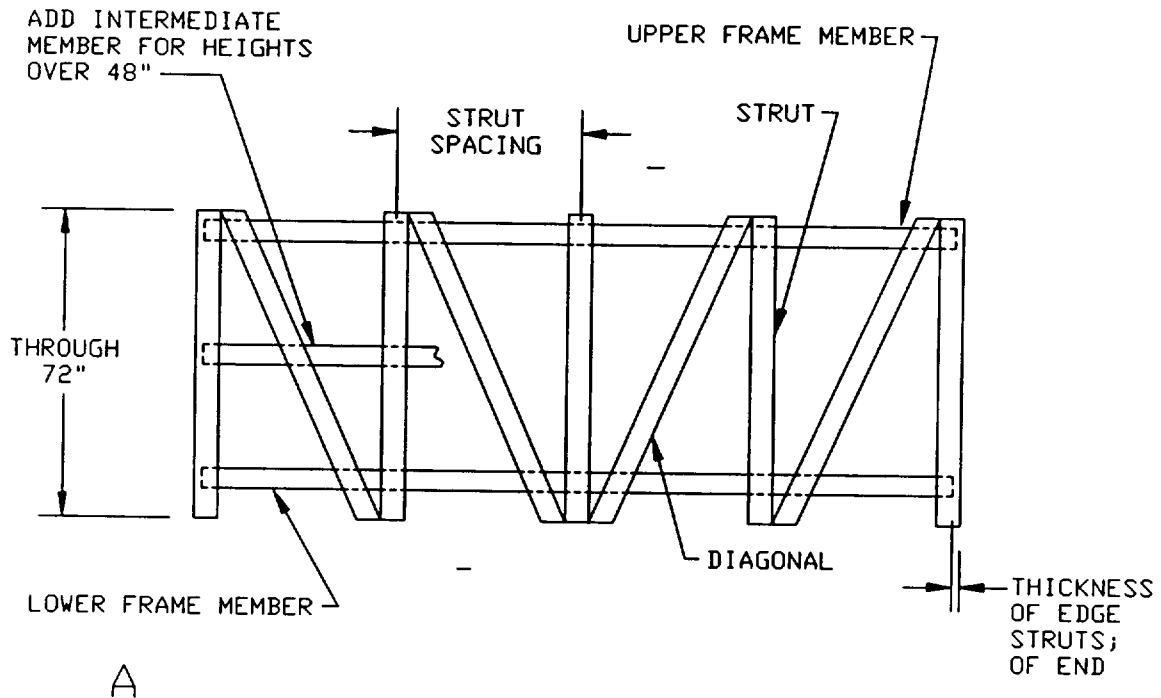

A

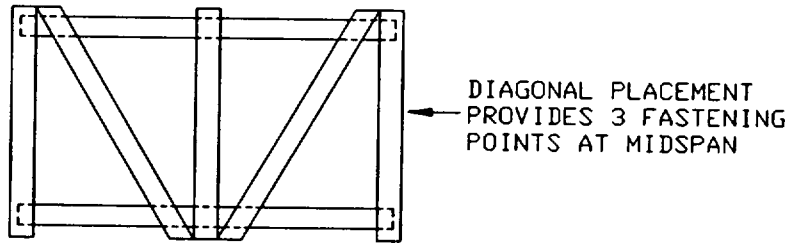

B

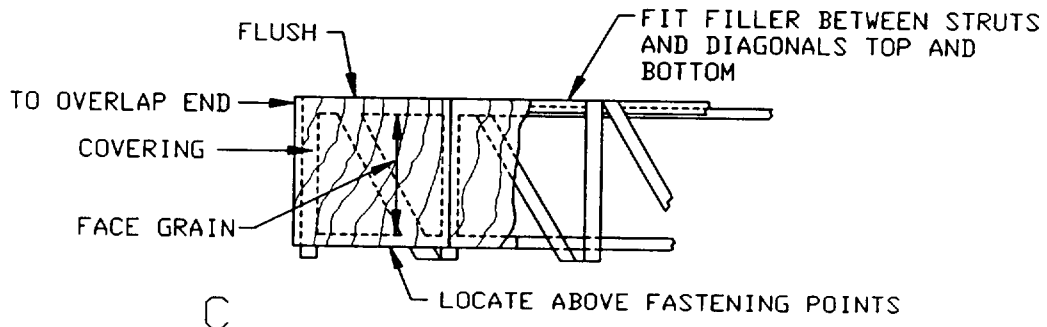

C

FIGURE 11. Single - panel sides for Type V, style B crates:
A, side of long crate; B, side of short crate;
C, covered side.

MIL-C-52950A

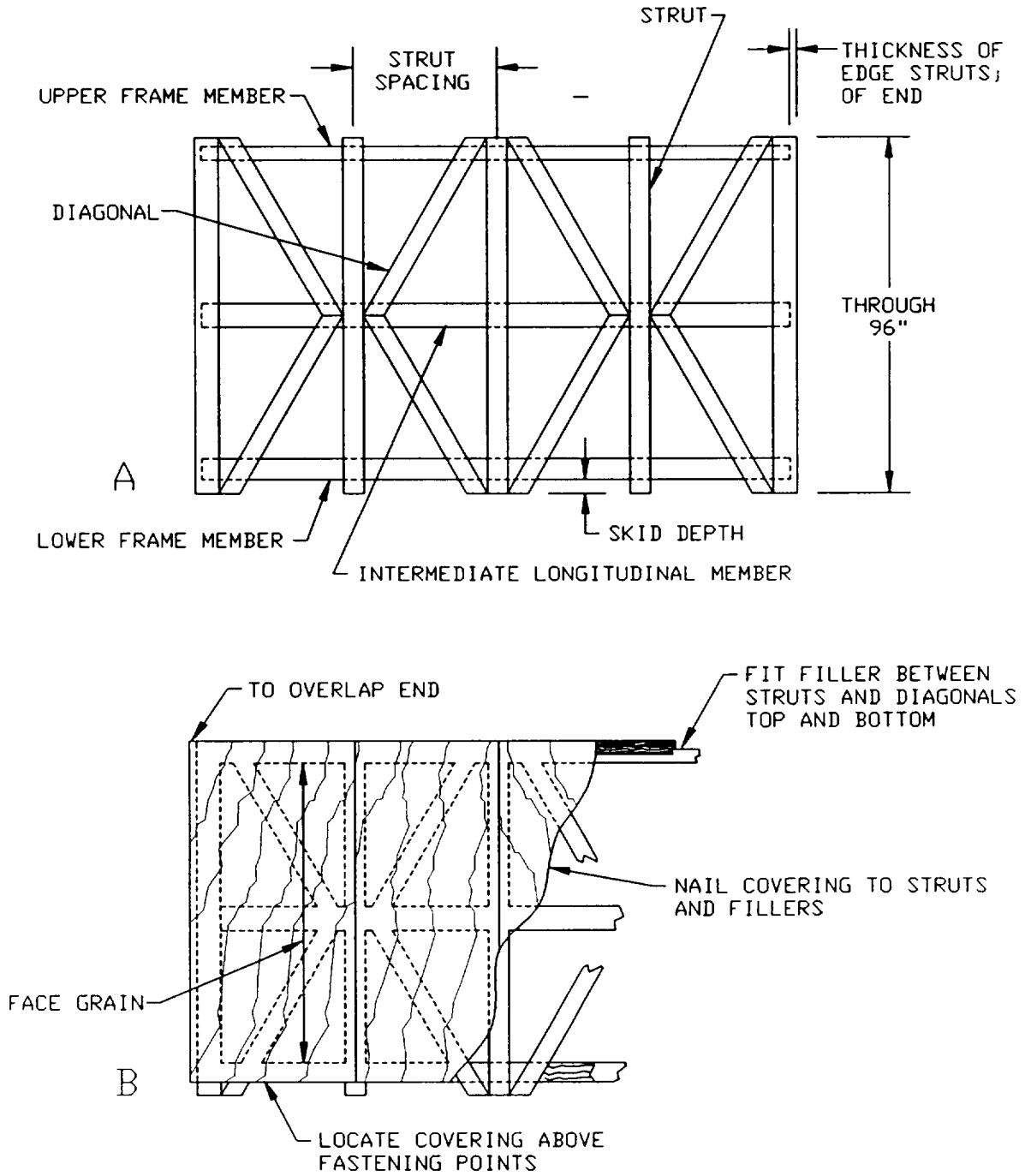

FIGURE 12. Double - panel sides for type V, style B crates for heights through 96 inches: A, open side; B, covered side.

MIL-C-52950A

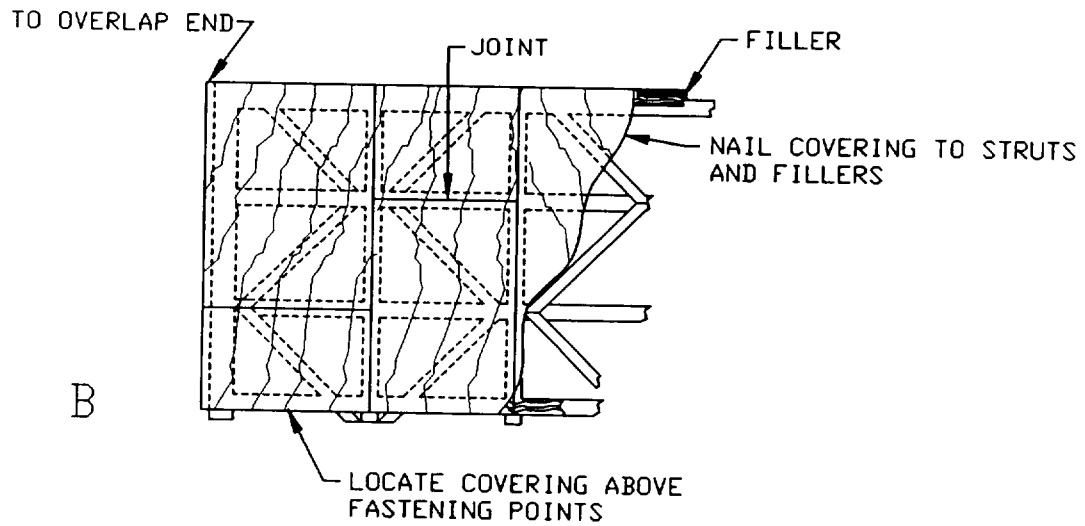
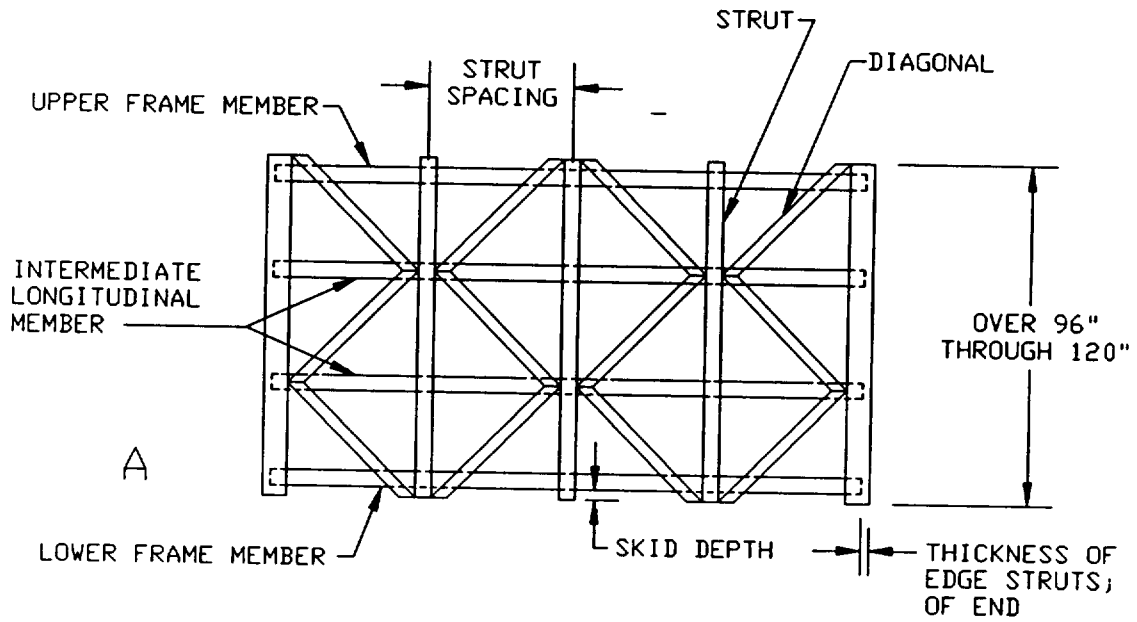

FIGURE 13. Triple - panel sides for type V, style B crates for heights over 96 inches: A, open side; B, covered side.

MIL-C-52950A

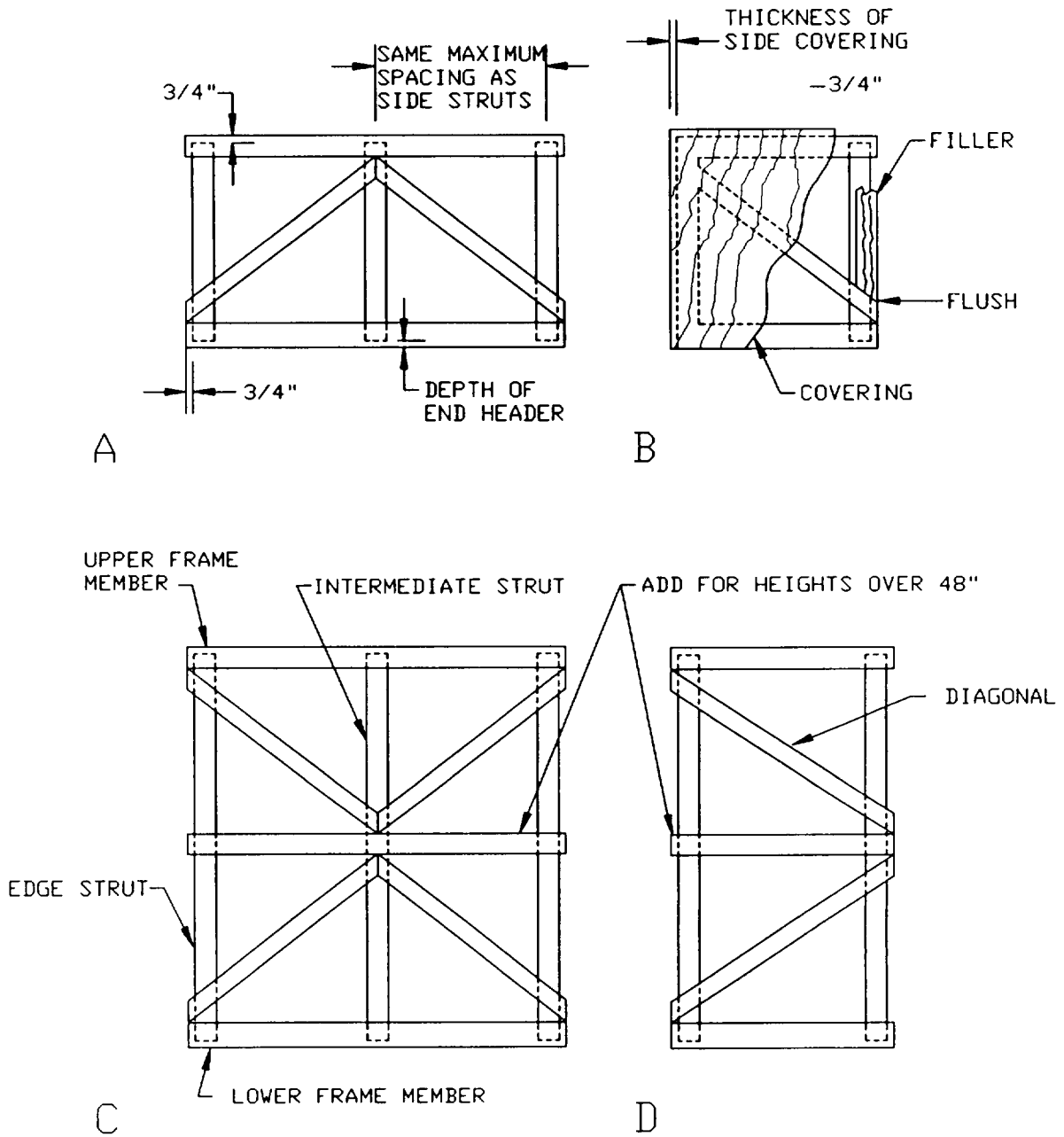

FIGURE 14. Ends for type V, style B crates: A, two - panel horizontal; B, single - panel (covered); C, four - panel; D, two - panel vertical.

MIL-C-52950A

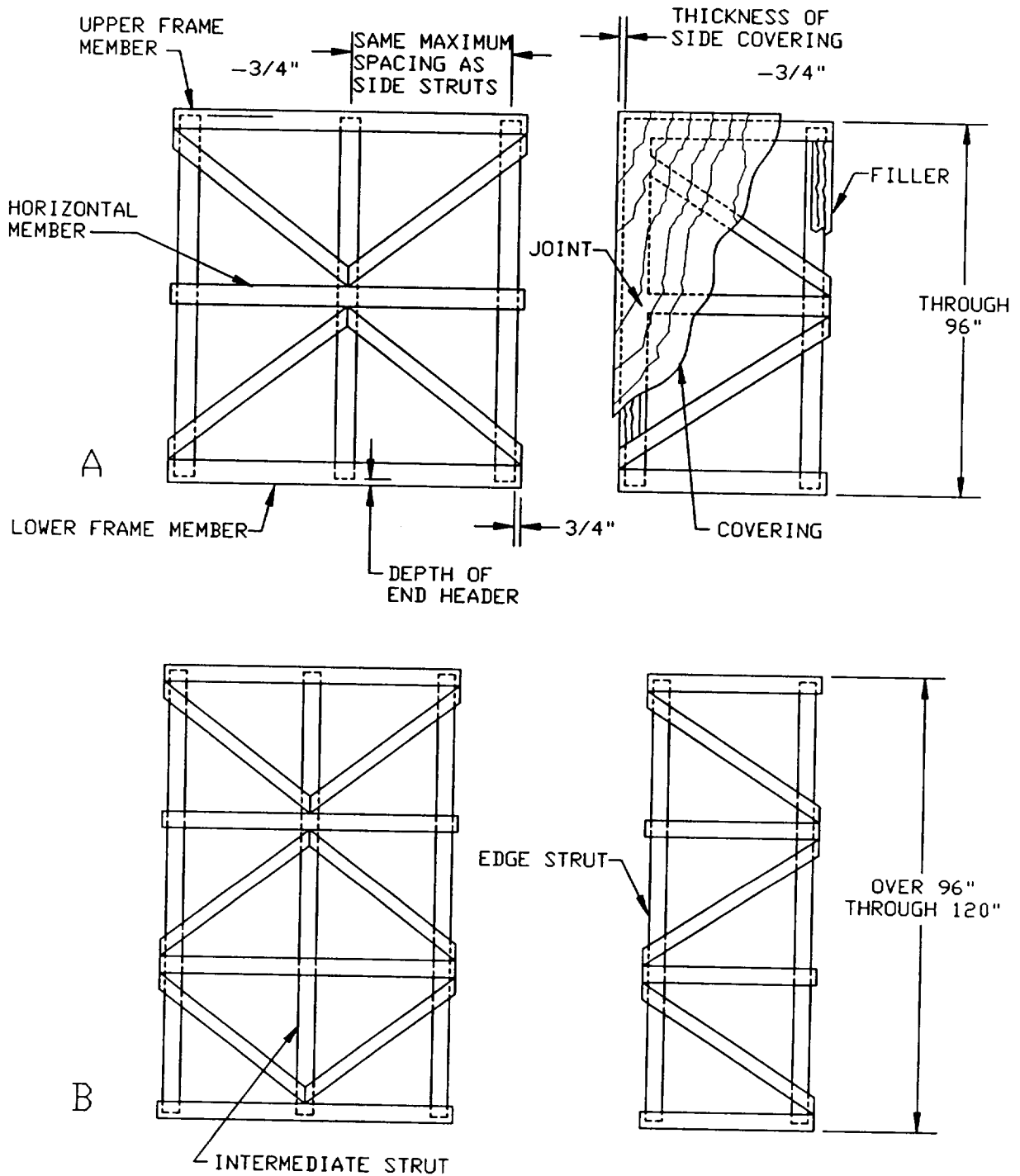

FIGURE 15. Ends for type V, style B crates: A, wide and narrow double - panel ends; B, wide and narrow triple - panel ends.

MIL-C-52950A

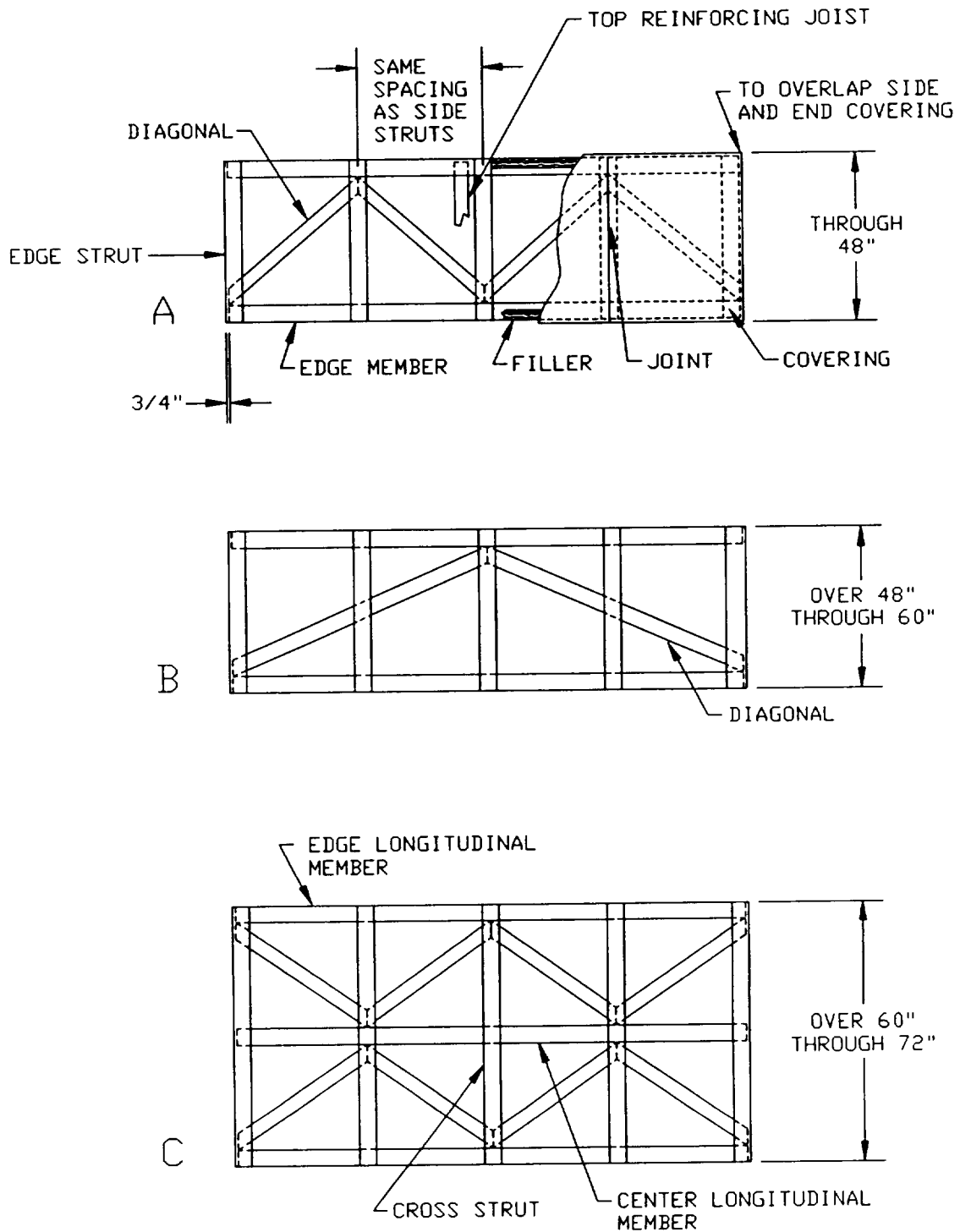

FIGURE 16. Tops for type V, style B crates:
A, narrow top; B, medium - wide top;
C, wide top.

MIL-C-52950A

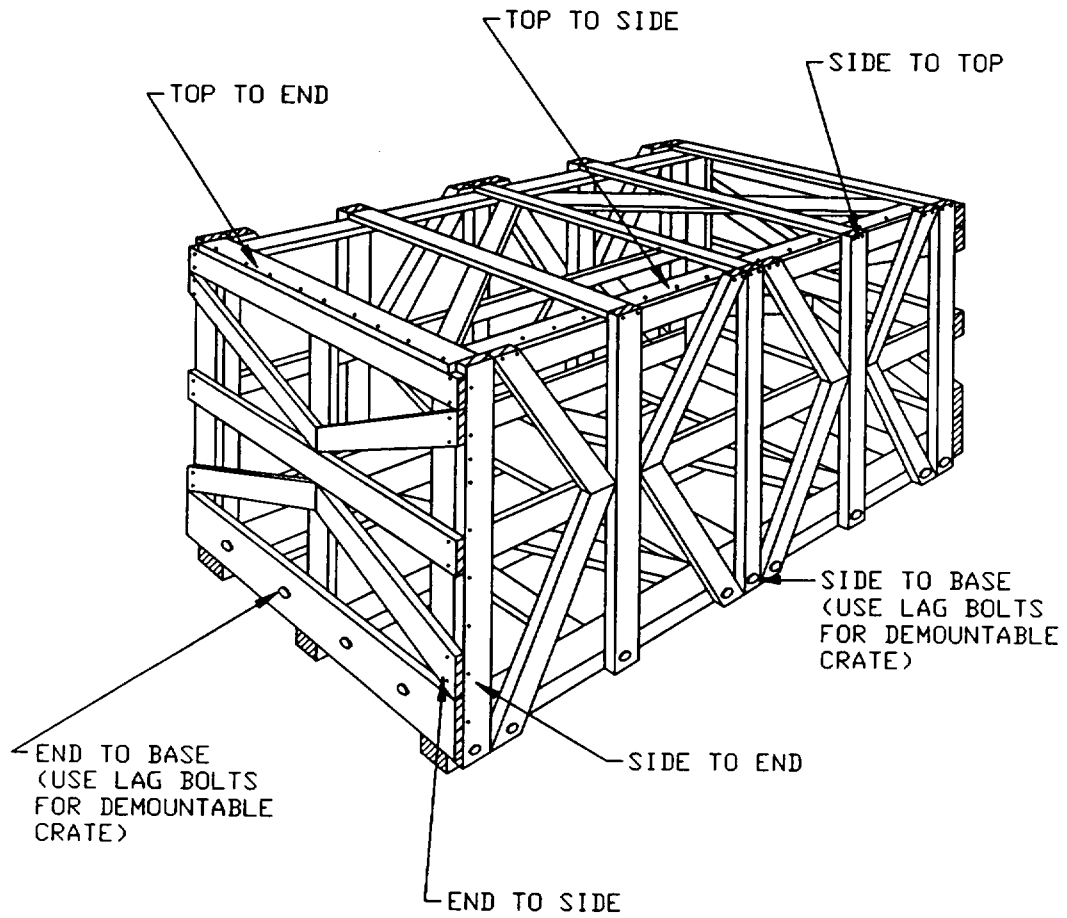

FIGURE 17. Type V, style B crate assembly (open).

MIL-C-52950A

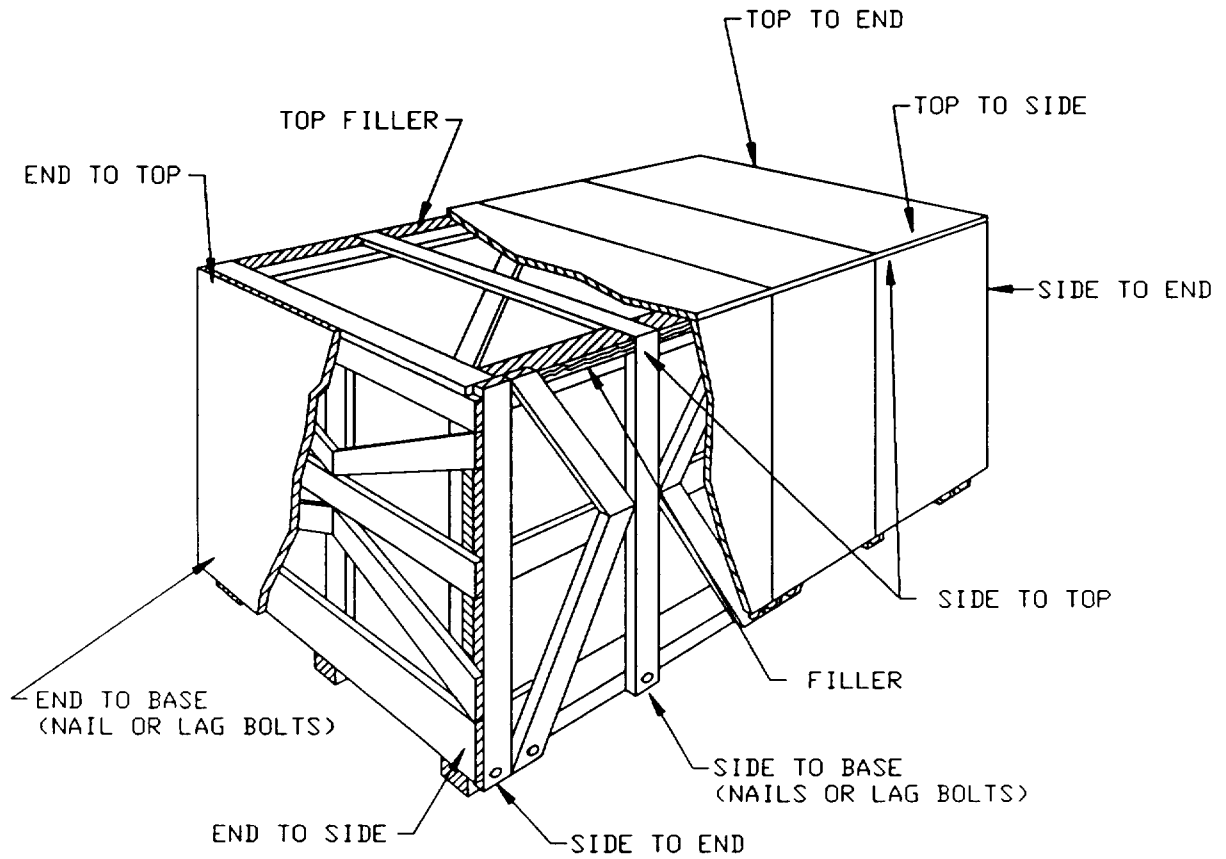

FIGURE 18. Type V, style B crate assembly (covered).