

MIL-C-39006C
 23 October 1978
 SUPERSEDING
 MIL-C-39006B
 28 August 1970

MILITARY SPECIFICATION

CAPACITORS, FIXED, ELECTROLYTIC (NONSOLID ELECTROLYTE), TANTALUM,
 ESTABLISHED RELIABILITY,
 GENERAL SPECIFICATION FOR

This specification is approved for use by all Departments and Agencies of the Department of Defense.

FAILURE RATE LEVEL L INACTIVE
 FOR DESIGN AFTER 27 MAY 1976

1. SCOPE

1.1 Scope. This specification covers tantalum, electrolytic (nonsolid electrolyte), fixed capacitors (polarized and nonpolarized), hermetically (see 6.7) and nonhermetically sealed in metal cases; style CLR65 and all tubular-foil styles are insulated. (See 6.1.) Capacitors covered by this specification have reliability established for failure rate (FR) levels ranging from 2.0 (or 1.0) percent to 0.001 percent per 1,000 hours in accordance with MIL-STD-690. These FR levels are established at a 60-percent confidence level and are maintained at a 10-percent producer's risk.

1.2 Classification. Capacitors covered by this specification are classified by the style, as specified (see 3.1).

2. APPLICABLE DOCUMENTS

2.1 Issues of documents. The following documents, of the issue in effect on date of invitation for bids or request for proposal, form a part of this specification to the extent specified herein.

SPECIFICATIONS

FEDERAL

QQ-S-571 - Solder; Tin Alloy; Tin-Lead Alloy; and Lead Alloy.

MILITARY

MIL-C-3965 - Capacitors, Fixed, Electrolytic (Nonsolid Electrolyte), Tantalum,
 General Specification For.
 MIL-C-39028 - Capacitors, Packaging of.

(See Supplement 1 for list of associated specification sheets.)

STANDARDS

MILITARY

MIL-STD-105 - Sampling Procedures and Tables for Inspection by Attributes.
 MIL-STD-202 - Test Methods for Electronic and Electrical Component Parts.
 MIL-STD-690 - Failure Rate Sampling Plans and Procedures.
 MIL-STD-790 - Reliability Assurance Program for Electronic Parts Specifications.
 MIL-STD-810 - Environmental Test Methods.
 MIL-STD-1276 - Leads, Weldable, for Electronic Component Parts.
 MIL-STD-1285 - Marking of Electrical and Electronic Parts.

(Copies of specifications, standards, drawings, and publications required by contractors in connection with specific procurement functions should be obtained from the procuring activity or as directed by the contracting officer.)

Beneficial comments (recommendations, additions, deletions) and any pertinent data which may be of use in improving this document should be addressed to: Commander, Naval Electronic Systems Command, Defense Standardization Program Branch, Department of the Navy, Washington, DC 20360, by using the self-addressed Standardization Document Improvement Proposal (DD Form 1426) appearing at the end of this document or by letter.

MIL-C-39006C

3. REQUIREMENTS

3.1 Specification sheets. The individual item requirements shall be as specified herein and in accordance with the applicable specification sheets. In the event of any conflict between requirements of this specification and the specification sheets, the latter shall govern. (See 6.2.)

3.2 Qualification. Capacitors furnished under this specification shall be products which are qualified for listing on the applicable qualified products list at the time set for opening of bids (see 4.4 and 6.3). Unless procured from the manufacturer or his authorized distributor listed or approved for listing on the qualified products list, parts furnished under this specification shall not be considered as having met the requirements of this specification.

3.3 Reliability. Reliability of capacitors furnished under this specification shall be established and maintained in accordance with the procedures and requirements specified in MIL-STD-790 and MIL-STD-690 with details specified in 4.1.1, 4.4.4, and 4.5.

3.4 Materials. Materials shall be as specified herein. However, when a definite material is not specified, a material shall be used which will enable the capacitors to meet the performance requirements of this specification. Acceptance or approval of any constituent material shall not be construed as a guaranty of the acceptance of the finished product.

3.4.1 Case. The case shall be of a corrosion-resisting metal or shall be plated or treated to resist corrosion.

3.4.1.1 Sleeving (when applicable). The sleeving shall be of a nonfungus nutrient material (cardboard or pressure-sensitive tape shall not be used). In addition, the material used shall not soften, creep, or shrink to a point where any part of the cylindrical portion of the case is left uncovered at any test temperature specified herein.

3.4.2 Solder. Solder shall be in accordance with QQ-S-571.

3.4.3 Soldering flux. Soldering flux shall be rosin, rosin and alcohol, or other flux as approved by the qualifying activity.

3.5 Design and construction. Capacitors shall be of the design, construction, and physical dimensions specified (see 3.1).

3.5.1 Case. Each capacitor shall be enclosed in a hermetically-(type G-glass seal or T-glass-to-tantalum seal) or nonhermetically-sealed (type E seal) metal case (see 3.1) which will prevent leakage or evaporation of the electrolyte and, in addition, will protect the capacitor element against the entry of contaminants.

3.5.1.1 Sleeving (when applicable). The sleeving shall extend 0.016 inch (0.41 mm) minimum, 0.062 inch (1.57 mm) maximum, beyond each end of the capacitor body; however, if a shrink-fitted insulation is used for the sleeving, it shall lap over the ends of the capacitor body.

3.5.2 Capacitor element. The capacitor element shall consist of an anode of etched or plain tantalum foil or a sintered tantalum slug, and a cathode of etched or plain tantalum foil or other suitable metal cathode (see 3.1).

3.5.3 Terminals. All terminals shall be permanently secured internally and externally, as applicable. All external joints shall be soldered or welded. Terminals shall be tin-lead coated as specified in MIL-STD-1276.

3.5.3.1 Axial-wire lead. The cathode terminal for style CLR65 shall conform to type C of MIL-STD-1276; all other axial-wire lead terminals shall conform to type N3 of MIL-STD-1276. The length and diameter shall be as specified (see 3.1).

MIL-C-39006C

3.5.3.2 Solder-lug. Solder-lug terminals shall be of a solid conductor of the shape specified (see 3.1).

3.6 Constant voltage conditioning. When capacitors are conditioned as specified in 4.7.2, there shall be no mechanical damage or leakage of electrolyte.

3.7 DC leakage. When measured as specified in 4.7.3, the dc leakage shall not exceed the applicable value specified (see 3.1).

NOTE: For nonpolarized capacitors, the value applies to measurements in both directions except that after environmental tests involving one directional polarization greater than 30 minutes, the value shall apply to the last poled direction only.

3.8 Capacitance. When measured as specified in 4.7.4, the capacitance shall be within tolerance of the nominal value specified (see 3.1).

3.9 Dissipation factor. When determined as specified in 4.7.5, the dissipation factor shall not exceed the applicable percent specified (see 3.1).

3.10 Seal (hermetically-sealed capacitors only, see 3.1). When capacitors are tested as specified in 4.7.6, there shall be no evidence of leakage.

3.11 Shock (specified pulse). When capacitors are tested as specified in 4.7.7, there shall be no intermittent contacts of 0.5 millisecond (ms) or greater duration, or arcing or any other indication of breakdown, nor shall there be any open- or short-circuiting, mechanical damage, or leakage of electrolyte.

3.12 Vibration, high frequency. When capacitors are tested as specified in 4.7.8, there shall be no intermittent contacts of 0.5 ms or greater duration, open- or short-circuiting, mechanical damage, or leakage of electrolyte. In addition, capacitors shall meet the following requirements:

DC leakage - - - - -	Shall not exceed 125 percent of the applicable value specified (see 3.1).
Capacitance- - - - -	Shall change not more than ± 5 percent from the initial measured value (see 3.8).
Dissipation factor - - - - -	Shall not exceed 115 percent of the applicable value specified (see 3.1).
Visual examination - - - - -	There shall be no evidence of harmful corrosion (as defined in 3.14), mechanical damage, obliteration of marking, or leakage of electrolyte.

3.13 Thermal shock. When tested as specified in 4.7.9, capacitors shall meet the following requirements:

DC leakage - - - - -	Except CLR79, shall not exceed 125 percent of the applicable value specified (see 3.1). For CLR79, see 3.1.
Capacitance- - - - -	Shall change not more than ± 5 percent from the initial measured value (see 3.8).
Dissipation factor - - - - -	Shall not exceed 115 percent of the applicable value specified (see 3.1).
External examination - - - - -	There shall be no evidence of leakage of electrolyte.

MIL-C-39006C

3.14 Salt spray (corrosion). When capacitors are tested as specified in 4.7.10, there shall be no harmful corrosion, and at least 90 percent of any exposed metal surface of the capacitor shall be protected by the finish. There shall be no unwrapping of, or mechanical damage to, the insulating sleeving, when applicable. Marking shall remain legible.

NOTE: Harmful corrosion shall be construed as being any type of corrosion which in any way interferes with the mechanical or electrical performance of the capacitor.

3.15 Solderability (capacitors with axial-wire lead terminals only, see 3.1). When capacitors are tested as specified in 4.7.11, the dipped portion of the terminals shall conform to the solid-wire termination criteria of method 208 of MIL-STD-202.

3.16 Terminal strength. When capacitors are tested as specified in 4.7.12, there shall be no loosening or permanent damage to the terminals, terminal weld or solder, or seal.

3.17 Surge voltage. When capacitors are tested as specified in 4.7.13, there shall be no intermittent contacts, open- or short-circuiting, mechanical damage, or leakage of electrolyte.

3.18 Moisture resistance. When tested as specified in 4.7.14, capacitors shall meet the following requirements:

DC leakage - - - - -	Shall not exceed 125 percent of the applicable value specified (see 3.1).
Capacitance- - - - -	Shall change not more than the percent specified (see 3.1) from the initial measured value (see 3.8).
Dissipation factor - - - - -	Shall not exceed 115 percent of the applicable value specified (see 3.1).
Visual examination - - - - -	There shall be no evidence of harmful corrosion (as defined in 3.14), mechanical damage, obliteration of marking, or leakage of electrolyte.

3.19 Dielectric withstanding voltage (insulated capacitors only, see 3.1). When capacitors are tested as specified in 4.7.15, the sleeving shall withstand the specified potential without breakdown.

3.20 Insulation resistance (insulated capacitors only, see 3.1). When measured as specified in 4.7.16, the insulation resistance shall be not less than 100 megohms.

3.21 Low temperature (storage). When tested as specified in 4.7.17, capacitors shall meet the following requirements:

DC leakage - - - - -	Shall not exceed the applicable value specified (see 3.1).
Capacitance- - - - -	Shall change not more than the percent specified (see 3.1) from the initial measured value (see 3.8).
Dissipation factor - - - - -	Shall not exceed the applicable value specified (see 3.1).
External examination - - - - -	There shall be no evidence of leakage of electrolyte.

3.22 Stability at low and high temperatures. When tested as specified in 4.7.18, capacitors shall meet the following requirements:

Step 1 (+25°C):

DC leakage - - - - -	Shall not exceed the applicable value specified (see 3.1).
Capacitance - - - - -	Shall be within the applicable tolerance specified (see 3.1).
Dissipation factor- - - - -	Shall not exceed the applicable value specified (see 3.1).

Step 2 (-55°C):

Impedance - - - - -	Shall not exceed the applicable value specified (see 3.1).
Capacitance - - - - -	Shall change not more than the percent specified (see 3.1) from the step 1 measured value.

Step 3 (+25°C):

DC leakage - - - - -	Shall not exceed the applicable value specified (see 3.1).
Capacitance - - - - -	Shall change not more than the percent specified (see 3.1) from the step 1 measured value.
Dissipation factor- - - - -	Shall not exceed the applicable value specified (see 3.1).

Step 4 (+85°C):

DC leakage - - - - -	Shall not exceed the applicable value specified (see 3.1).
Capacitance - - - - -	Shall change not more than the percent specified (see 3.1) from the step 1 measured value.
Dissipation factor- - - - -	Shall not exceed the applicable value specified (see 3.1).

Step 5 (+125°C):

DC leakage - - - - -	Shall not exceed the applicable value specified (see 3.1).
Capacitance - - - - -	Shall change not more than the percent specified (see 3.1) from the step 1 measured value.
Dissipation factor- - - - -	Shall not exceed the applicable value specified (see 3.1).

Step 6 (+25°C):

DC leakage - - - - -	Shall not exceed the applicable value specified (see 3.1).
Capacitance - - - - -	Shall change not more than the percent specified (see 3.1) from the step 1 measured value.
Dissipation factor- - - - -	Shall not exceed the applicable value specified (see 3.1).

MIL-C-39006C

3.23 Reverse voltage (when specified, see 3.1). When tested as specified in 4.7.19, capacitors shall meet the following requirements:

DC leakage - - - - -	Shall not exceed 125 percent of the applicable value specified (see 3.1).
Capacitance- - - - -	Shall change not more than ± 10 percent from the initial measured value (see 3.8).
Dissipation factor - - - - -	Shall not exceed the applicable value specified (see 3.1).

3.24 Life at 85°C.

3.24.1 2,000-hour (qualification inspection). When tested as specified in 4.7.20.1, capacitors shall meet the following requirements:

DC leakage (at 85°C and 25°C) - - -	Shall not exceed the applicable value specified (see 3.1).
Capacitance- - - - -	Shall change not more than the percent specified (see 3.1) from the initial measured value (see 3.8).
Dissipation factor - - - - -	Shall not exceed the applicable value specified (see 3.1).
Visual examination - - - - -	There shall be no damage, obliteration of marking, or leakage of electrolyte.

3.24.2 10,000-hour (group B inspection) and extended life. When tested as specified in 4.7.20.2 or 4.7.20.3, capacitors shall meet the following requirements:

DC leakage (at 85°C) - - - - -	Shall not exceed 125 percent of the applicable value specified (see 3.1).
DC leakage (at 25°C) - - - - -	Shall not exceed the applicable value specified (see 3.1).
Capacitance- - - - -	Shall change not more than the percent specified (see 3.1) from the initial measured value (see 3.8).
Dissipation factor - - - - -	Shall not exceed the applicable value specified (see 3.1).
Dielectric withstanding voltage (insulated capacitors only)- - -	Shall be as specified in 3.19.
Insulation resistance (insulated capacitors only) - - - - -	Shall be as specified in 3.20.
Visual examination - - - - -	There shall be no damage, obliteration of marking, or leakage of electrolyte.

3.25 AC ripple life at 85°C (qualification and group C inspection)(CLR79 only). When tested as specified in 4.7.21, capacitors shall meet the following requirements:

DC leakage - - - - -	Shall not exceed the applicable value specified (see 3.1).
Capacitance - - - - -	Shall not exceed the applicable value specified (see 3.1).
Dissipation factor - - - - -	Shall not exceed the applicable value specified (see 3.1).
Visual examination - - - - -	There shall be no damage, obliteration of marking, or leakage of electrolyte.

3.26 Vacuum life (hermetically-sealed capacitors only, except CLR10, CLR14, CLR17, and CLR79). When tested as specified in 4.7.22, capacitors shall meet the following requirements:

DC leakage - - - - -	Shall not exceed the applicable value specified (see 3.1).
Capacitance- - - - -	Shall change not more than +20 percent from the initial measured value (see 3.8).
Dissipation factor - - - - -	Shall not exceed the applicable value specified (see 3.1).
Weight loss- - - - -	Shall not exceed 4.1 milligrams.

3.27 Life at 125°C. When tested as specified in 4.7.23, capacitors shall meet the following requirements:

DC leakage (at 125°C and 25°C) - - - -	Shall not exceed the applicable value specified (see 3.1).
Capacitance- - - - -	Shall change not more than the percent specified (see 3.1) from the initial measured value (see 3.8).
Dissipation factor - - - - -	Shall not exceed the applicable value specified (see 3.1).
Dielectric withstanding voltage (insulated capacitors only)- - - - -	Shall be as specified in 3.19.
Insulation resistance (insulated capacitors only) - - - - -	Shall be as specified in 3.20.
Visual examination - - - - -	There shall be no damage, obliteration of marking, or leakage of electrolyte.

3.27.1 10,000-hour (group B inspection). When tested as specified in 4.7.23.1, capacitors shall meet the following requirements:

DC leakage (at 125°C)- - - - -	Shall not exceed 125 percent of the applicable value specified (see 3.1).
DC leakage (at 25°C) - - - - -	Shall not exceed the applicable value specified (see 3.1).
Capacitance- - - - -	Shall change not more than the percent specified (see 3.1) from the initial measured value (see 3.8).
Dissipation factor - - - - -	Shall not exceed the applicable value specified (see 3.1).

MIL-C-39006C

Dielectric withstanding voltage (insulated capacitors only)-	-----	Shall be as specified in 3.19.
Insulation resistance (insulated capacitors only)-	-----	Shall be as specified in 3.20.
Visual examination	-----	There shall be no damage, obliteration of marking, or leakage of electrolyte.

3.28 Barometric pressure (reduced). When capacitors are tested as specified in 4.7.24, there shall be no flashover, breakdown, or harmful deformation of the case, and no mechanical damage, obliteration of marking, or leakage of electrolyte.

3.29 Fungus. The manufacturer shall certify that all external materials are fungus resistant or shall perform the test specified in 4.7.25. When capacitors are tested as specified in 4.7.25, examination shall disclose no evidence of fungus growth on the external surface of the capacitor.

3.30 Resistance to solvents. When capacitors are tested as specified in 4.7.26, marking shall remain legible and shall not smear or rub off. In addition, there shall be no visible indication of damage or deterioration to the capacitor body.

3.31 Resistance to soldering heat. When tested as specified in 4.7.27, capacitors shall meet the following requirements:

DC leakage	-----	Shall not exceed the applicable value specified (see 3.1).
Capacitance-	-----	Shall change not more than the percent specified (see 3.1) from the initial measured value (see 3.8).
Dissipation factor	-----	Shall not exceed the applicable value specified (see 3.1).

3.32 Marking. Marking of capacitors shall conform to method I of MIL-STD-1285 and shall include the part number, "JAN" brand, trademark, source code, date code, lot symbol, capacitance (in μF), and rated voltage. Capacitors shall be marked as shown in the following example:

EXAMPLE:

M39006/	
01-3001	- Part number.
JAN	- "JAN" brand and trademark.
12345	- Source code.
7815A	- Date code and lot symbol.
15 μF 15V	- Capacitance and rated voltage.

Polarity marking for polarized units shall be marked as specified (see 3.1).

3.32.1 Military part number. The military part number shall consist of the letter "M", the basic number of the specification sheet, and an assigned dash number (see 3.1), as shown in the following:

M 39006/01 -3001

Military designator	Specification sheet number	Dash number
---------------------	----------------------------	-------------

3.32.2 "JAN" and "J" marking. The United States Government has adopted, and is exercising legitimate control over, the certification marks "JAN" and "J", respectively, to indicate electrical equipment, namely, resistors, capacitors, electron tubes and the like, procured by, or manufactured for use by, or for the Government in accordance with standard Government specifications. Accordingly, capacitors procured to, and meeting all of, the criteria specified herein and in applicable specification sheets shall bear the certification mark "JAN", except that capacitors too small to bear the certification mark "JAN" shall bear the letter "J". Capacitors furnished under contracts or orders which either permit or require deviation from the conditions or requirements specified herein and in applicable specification sheets shall not bear "JAN" or "J".

MIL-C-39006C

In the event a capacitor sample fails to meet the requirements of this specification and the applicable specification sheets, the manufacturer shall remove the "JAN" or "J" from the sample tested and also from all capacitors represented by the sample. The United States Government has obtained Certificate of Registration No. 504,860 for the certification mark "JAN".

3.32.3 Marking when supplying to higher FR levels. A manufacturer supplying to higher FR levels as provided by MIL-STD-690 shall not remark the parts unless specified in the contract or purchase order (see 6.2).

3.32.4 Non-established reliability (ER) marking. An ER part manufactured in accordance with this specification may be marked and furnished as the non-ER version of part in MIL-C-3965, if produced on the same assembly line or lines and provided it is subjected to and meets all the inspection requirements of the ER part.

3.33 Workmanship. Capacitors shall be processed in such a manner as to be uniform in quality and shall be free from pits, harmful corrosion (as defined in 3.14), cracks, rough edges, and other defects that will affect life, serviceability, or appearance.

3.33.1 Terminals and end seals. All terminals and end seals shall be free of grease or other foreign material.

3.33.2 Insulating sleeving (when applicable). Insulating sleeving shall fit the container case in such a manner that there are no loose seams or ragged ends.

4. QUALITY ASSURANCE PROVISIONS

4.1 Responsibility for inspection. Unless otherwise specified in the contract, the contractor is responsible for the performance of all inspection requirements as specified herein. Except as otherwise specified in the contract, the contractor may use his own or any other facilities suitable for the performance of the inspection requirements specified herein, unless disapproved by the Government. The Government reserves the right to perform any of the inspections set forth in the specification where such inspections are deemed necessary to assure supplies and services conform to prescribed requirements.

4.1.1 Reliability assurance program. A reliability assurance program shall be established and maintained in accordance with MIL-STD-790, with the following exceptions:

- a. The following shall apply in lieu of paragraph 5.2.7(j): "The manufacturer shall as a minimum be able to identify the time period during which the final production operation was performed on each item of product prior to final test. The date or lot code marked on each part shall be identified to an inspection lot."
- b. Paragraph 5.2.11.3 shall not apply.

Evidence of such compliance shall be verified by the qualifying activity of this specification as a prerequisite for qualification and continued qualification.

4.2 Classification of inspections. The inspections specified herein are classified as follows:

- a. Qualification inspection (see 4.4).
- b. Verification of qualification (see 4.5).
- c. Quality conformance inspection (see 4.6).

4.3 Inspection conditions and methods.

4.3.1 Conditions. Unless otherwise specified herein, all inspections shall be performed in accordance with the test conditions specified in the "GENERAL REQUIREMENTS" of MIL-STD-202.

4.3.2 Methods.

MIL-C-39006C

4.3.2.1 AC measurements. AC measurements shall be made at a frequency of 120 \pm 5 hertz (Hz). The magnitude of the ac voltage shall be equal to or less than 1.0 volt root mean square (rms). Except as specified in the following, the dc bias voltage shall be 2.2 $\begin{smallmatrix} +0.0 \\ -1.0 \end{smallmatrix}$ volts for all ac measurements.

- a. 5.0 $\begin{smallmatrix} +0.0 \\ -1.0 \end{smallmatrix}$ Vdc (50- and 75-volt capacitors, styles CLR25 and CLR71 only).
- b. 10.0 $\begin{smallmatrix} +0.0 \\ -1.0 \end{smallmatrix}$ Vdc (100-, 125-, and 150-volt capacitors, styles CLR25, CLR71, and CLR79 only).

The ratio of ac voltage to dc bias voltage shall be such that no reversal of dc voltage will occur across the capacitor.

4.3.2.2 Reference measurements. When requirements are based on comparative measurements made before and after conditioning, the reference measurement shall be considered the last measurement made at 25° \pm 5°C prior to conditioning. Unless reference measurements have been made within 30 days prior to the beginning of conditioning, they shall be repeated.

4.3.3 Power supply. The power supply used for life testing shall have a regulation of \pm 2 percent or less of the applicable applied test voltage. The power supply used for dc leakage current measurements shall be stabilized to at least \pm 100 parts per million. No voltage fluctuations shall occur during measurements that would produce a variation in the current measurement.

4.4 Qualification inspection. ^{1/} Qualification inspection shall be performed at a laboratory acceptable to the Government (see 6.3) on sample units produced with equipment and procedures normally used in production.

4.4.1 Sample size. The number of capacitors to be subjected to qualification inspection shall be as specified in table I or in the appendix to this specification. Each capacitor style shall be qualified separately.

4.4.2 Inspection routine. The sample shall be subjected to the inspections specified in table I, in the order shown. Except as specified in table I, all sample units shall be subjected to the inspections of group I. For group II, two sample units shall be subjected to the visual and mechanical examination (internal) and the remaining sample units shall be subjected to the tests shown. These sample units shall then be divided as specified in table I for groups III to IX inclusive, and subjected to the inspections for their particular group.

4.4.3 Failures. Failures in excess of those allowed in table I shall be cause for refusal to grant qualification approval.

4.4.4 FR qualification and lot conformance FR inspection. FR qualification and lot conformance FR inspection shall be in accordance with the general and detailed requirements of MIL-STD-690 and the following details:

- a. Procedure I - Qualification at the initial FR level. Level L or M, as applicable (see 3.1), of FRSP-60 shall apply. Upon completion of the 2,000-hour qualification test (group VI, table I), the entire life test sample shall be continued on test as specified in 4.7.20.3.1.
- b. Procedure II - Extension of qualification to lower FR levels. To extend qualification to the R and S FR levels, data from two or more voltage groups within a style and of similar construction (see 4.6.1.1) may be combined.
- c. Procedure III - Maintenance of FR level qualification. Maintenance period B of FRSP-10 shall apply. Regardless of the number of production lots produced during this period, the specified number of unit hours shall be accumulated to maintain qualification. (See 4.5f.) Styles in groups I and V (see 4.6.1.1) may be combined for FR level maintenance of all levels.
- d. Procedure IV - Lot conformance FR inspection. Lot conformance FR inspection shall be in accordance with 4.6.1.3.2 or 4.6.1.3.3, as applicable.

^{1/} Qualification approval will be based on the successful completion of the tests specified in table I, and will not be withheld pending completion of the extended life test of 4.4.4a.

4.5 Verification of qualification. Every 6 months, the manufacturer shall compile a summary of the results of quality conformance inspections and extended FR test data, in the form of a verification of qualification report, and forward it to the qualifying activity within 30 days after the end of the reporting period as the basis of continued qualification approval. In addition, the manufacturer shall immediately notify the qualifying activity whenever the FR data indicates that the manufacturer has failed to maintain his qualified FR level. Continuation shall be based on evidence that, over the 6-month period, the following has been met:

- a. The manufacturer continues to meet the requirements of MIL-STD-790.
- b. The manufacturer has not modified the design of the item.
- c. The specification requirements for the item have not been amended so as to affect the character of the item.
- d. Lot rejection for group A inspection does not exceed 10 percent or one lot, whichever is greater.
- e. The requirements of groups B and C inspections are met.
- f. The records of all FR tests combined substantiate that the L, M, or P FR level has been maintained or that the manufacturer continues to meet the R or S FR level for which qualified, although the total component hours of testing does not, as yet, meet the requirements of 4.4.4c.

In the event that no production occurred during the reporting period, a report shall be submitted certifying that the company still has the capabilities and facilities necessary to produce the item. If during 2 consecutive reporting periods there has been no production, the manufacturer may be required, at the discretion of the qualifying activity, to submit the capacitors to testing in accordance with the qualification inspection requirements.

If group C test requirements were not met and the manufacturer has taken corrective action satisfactory to the Government, the forwarding of the verification of qualification report may be delayed until within 30 days after completion of retesting of the group C inspections. In this case, the qualifying activity shall be notified of this condition within the time the original verification of qualification report was due. All reports shall be certified by a responsible company official.

4.5.1 Records. Maintenance of life test and FR level records shall be as specified in MIL-STD-690.

4.6 Quality conformance inspection.

4.6.1 Inspection of product for delivery. Inspection of product for delivery shall consist of group A inspection (for FR levels M, P, R, and S) or groups A and B inspections (for FR level L).

4.6.1.1 Inspection lot. An inspection lot, as far as practicable, shall consist of all capacitors from the same production line or lines, produced under essentially the same conditions and offered for inspection during a single work-week. The following styles may be grouped:

- a. Group I - Styles CLR25, CLR27, CLR35, CLR37, CLR71, and CLR73 (elastomer seals).
- b. Group II - Style CLR65.
- c. Group III - Styles CLR10, CLR14, and CLR17.
- d. Group IV - Style CLR69.
- e. Group V - Styles CLR25, CLR27, CLR35, CLR37, CLR71, and CLR73 (hermetic seals).

4.6.1.2 Group A inspection. Group A inspection shall consist of the examination and tests specified in table II, in the order shown.

4.6.1.2.1 Sampling plan. The tests in group A shall be performed on all capacitors offered for acceptance. The acceptable quality levels (AQL) and limiting quality (LQ) where $P_a = 10$ percent shall be as specified in table II. At the option of the manufacturer, numerically lower AQL's may be used as long as the specified LQ is not exceeded numerically. Major and minor defects shall be as defined in MIL-STD-105 and as specified in table II. Units selected shall be representative of all capacitance values and voltages produced.

MIL-C-39006C

TABLE I. Qualification Inspection.

Examination or test	Requirement paragraph	Test paragraph	Number of sample units to be inspected		Inspected Nonhermetically sealed styles	Number of failures allowed		Nonhermetically sealed styles
			Hermetically sealed styles CLR10, 14 17	Other styles		Hermetically sealed styles CLR10, 14, 17	Other styles	
Group I 2/								
Constant voltage conditioning - - -	3.6	4.7.2	125	235	192	0	0	0
DC leakage - - - - -	3.7	4.7.3						
Capacitance - - - - -	3.8	4.7.4						
Dissipation factor - - - - -	3.9	4.7.5						
Seal, condition A (hermetically-sealed styles) - - - - -	3.10	4.7.6.1						
Group II								
Visual and mechanical examination (internal) - - - - -	3.1, 3.4, and 3.5	4.7.1	2	2	2	0	0	0
Visual and mechanical examination (external) 2/ - - - - -	3.1, 3.4	4.7.1	123 4/	233 4/	190 4/	1	1	1
Material - - - - -	3.1, 3.5							
Design and construction - - - - -	3.32							
Marking 3/ - - - - -	3.33							
Workmanship - - - - -								
Group III								
Shock (specified pulse) - - - - -	3.11	4.7.7	4	24 5/	12			
Vibration, high frequency - - - - -	3.12	4.7.8						
Thermal shock - - - - -	3.13	4.7.9						
Salt spray (corrosion) - - - - -	3.14	4.7.10						
Group IV								
Solderability (axial-wire lead styles) - - - - -	3.15	4.7.11	4	12	12			1
Terminal strength - - - - -	3.16	4.7.12						
Surge voltage - - - - -	3.17	4.7.13						
Moisture resistance - - - - -	3.18	4.7.14						
Dielectric withstanding voltage (insulated styles) - - - - -	3.19	4.7.15						
Insulation resistance (insulated styles) - - - - -	3.20	4.7.16						
Low temperature (storage) - - - - -	3.21	4.7.17						
Seal, condition C (hermetically-sealed styles) - - - - -	3.10	4.7.6.2				1		

See footnotes at end of table.

TABLE I. Qualification inspection - Continued.

Examination or test	Requirement paragraph	Test paragraph	Number of sample units to be inspected		Number of failures allowed		Nonhermetically sealed styles
			Hermetically sealed styles CLR10, 14, 17	Other styles	Hermetically sealed styles CLR10, 14, 17	Other styles	
<u>Group V</u> Stability at low and high temperatures Reverse voltage (when specified, see 3.1)	3.22	4.7.18	4	12	12		
	3.23	4.7.19	---	---	---		
<u>Group VI</u> Life at 85°C (2,000 hour)	3.24.1	4.7.20.1	102	102	102	16/	16/
	3.25	4.7.21	---	32/	---	1	---
---			---	---	1	---	
<u>Group VIII</u> Vacuum life (hermetically-sealed styles except CLR10, 14, 17, and 79)	3.26	4.7.22	---	6	---	1	---
	3.27 3.28	4.7.23 4.7.24	3	40	40	1	1
---			---	---	---	---	
<u>Group IX</u> Life at 125°C Barometric pressure (reduced)	3.29	4.7.25	2	5	5		
	3.30 3.31	4.7.26 4.7.27	3	6	6	0	0
<u>Group X</u> Fungus Resistance to solvents Resistance to soldering heat	3.29	4.7.25	2	5	5		
	3.30 3.31	4.7.26 4.7.27	3	6	6	0	0

1/ A sample unit having one or more defects shall be considered as a single failure.
 2/ Nondestructive tests (see 20.2).
 3/ Marking defects are based on visual examination only and shall be charged only for illegible, incomplete, or incorrect marking.
 4/ One additional sample unit is included in each sample size to permit substitution for the failure allowed in group II.
 5/ 24 units, 6 of each case size.
 6/ For FR level L, the maximum number of failures allowed shall be based on the cumulative unit hours required for verification at 2% per 1000 hours.
 7/ 32 units, 8 of each case size.
 8/ Certification of fungus resistance may be substituted for testing.

MIL-C-39006C

4.6.1.2.2 Manufacturer's production inspection. If the manufacturer performs tests equal to or more stringent than those specified in subgroup 1, table II, as the final step of his production process, group A, subgroup 1 inspection may be waived and the data resulting from the manufacturer's production tests may be used instead. Authority to waive the subgroup 1 inspection shall be granted by the qualifying activity only. The following criteria shall be complied with:

- a. Tests conducted by the manufacturer during production shall be clearly identical to or more stringent than that specified for subgroup 1. Test conditions shall be equal to or more stringent than those specified for subgroup 1 tests.
- b. Manufacturer subjects 100 percent of the product supplied under this specification to his production tests.
- c. The parameters measured and the failure criteria shall be the same as, or more stringent than, those specified herein.
- d. The lot rejection criteria is the same as, or more stringent than, those specified herein.
- e. The manufacturer shall make available all information concerning the test procedures and instrumentation used in his production tests. This data shall be provided as part of the evaluation required for MIL-STD-790. The manufacturer shall also make available to the Government all records of all detail test data resulting from production tests.
- f. Once approved, the manufacturer shall not change the test procedures or criteria without prior notification and concurrence by the qualifying activity.

TABLE II. Group A inspection.

Examination or test	Requirement paragraph	Test paragraph	Quality levels (percent defective)	
			Major	Minor
<u>Subgroup 1 (all FR levels)</u>				
Constant voltage conditioning - - - - -	3.6	4.7.2	} Not applicable (100% inspection)	
DC leakage- - - - -	3.7	4.7.3		
Capacitance - - - - -	3.8	4.7.4		
Dissipation factor- - - - -	3.9	4.7.5		
Seal, condition A (hermetically-sealed styles) - - - - -	3.10	4.7.6.1		
<u>Subgroup 2 (all FR levels)</u>				
Visual and mechanical examination (external):	---	4.7.1	} 1.0 (AQL) 7.6 (LQ)	} 4.0 (AQL) 18.0 (LQ)
Design and construction - - - - -	3.1, 3.5	---		
Marking - - - - -	3.32	---		
Workmanship - - - - -	3.33	---		

4.6.1.2.3 Rejected lots. Lots rejected by the subgroup 2 inspection shall be segregated from new lots and those lots that have passed inspection. Such rejected lots may be offered for acceptance only if the manufacturer inspects all units in the lot for those quality characteristics found defective in the sample and, after removing all defective units found, reinspects the lot using the tightened inspection procedure of MIL-STD-105. Resubmitted lots shall be kept separate from new lots and shall be clearly identified as resubmitted lots. If, during the 100-percent inspection of subgroup 1 screening requires that over 5 percent of the capacitors be discarded, the lot shall be rejected.

NOTE: Sufficient samples shall be withheld for groups B and C inspections.

4.6.1.3 Group B inspection. Group B inspection for all FR levels shall consist of the tests specified in table III, in the order shown, and shall be performed on sample units which have been subjected to and have passed the applicable (by FR level) tests of group A inspection.

4.6.1.3.1 Sampling plan.

4.6.1.3.1.1 Subgroup 1. The sampling plan for subgroup 1 shall be in accordance with MIL-STD-105 for special inspection level S-4. (The sample size selected for these tests shall be based on the lot size.) The AQL and LQ shall be as specified in table III. At the option of the manufacturer, a numerically lower AQL may be used as long as the LQ is not exceeded numerically.

4.6.1.3.1.2 Subgroup 2. A minimum of 20 sample units shall be selected at random from each inspection lot and shall be inspected as specified in subgroup 2, table III. Units selected may be subjected to specified test before 1 month has elapsed.

TABLE III. Group B inspection.

Test	Requirement paragraph	Test paragraph	Sample selection (all FR levels)
<u>Subgroup 1</u>			
Stability at low and high temperatures - - - - -	3.22	4.7.18	1.5% AQL 10.0% LQ
<u>Subgroup 2</u>			
Thermal shock- - - - -	3.13	4.7.9	20 ^{3/}
Life (10,000-hour @ 85°C) ^{1/}	3.24.2	4.7.20.2	10
Life (10,000-hour @ 125°C) ^{1/}	3.27.1	4.7.23.1	10 ^{2/}

^{1/} Only unit hours generated at 85°C shall be used for FR level computation.

^{2/} One failure (maximum) permitted per 80,000 unit hours.

^{3/} Twenty samples minimum; reject criteria shall be 0.65% AQL and 11.0% LQ.

4.6.1.3.2 Disposition of sample units. Sample units which have been subjected to group B inspection shall not be delivered on the contract.

4.6.1.3.3 Failure in group B inspection. If an inspection lot is rejected as a result of failure to pass group B inspection, the lot shall not be resubmitted. However, if the lot is rejected because of failure to pass stability at low and high temperature test of subgroup 1, the lot may be resubmitted provided the defective units are removed and the lot is then subjected to 100-percent inspection for those characteristics found defective. Resubmitted lots shall be kept separate from new lots, and shall be clearly identified as resubmitted lots. Even though the lot has been rejected, those units which were pre-designated for extended life testing shall remain or be placed on test for the full length of time.

4.6.2 Periodic inspection. Periodic inspection shall consist of group C inspection. Delivery of products which have passed groups A and B inspections shall not be delayed pending the results of periodic inspection.

4.6.2.1 Group C inspection. Group C inspection shall be performed on sample units which have been subjected to and have passed the applicable tests (by FR level) for group A inspection and shall consist of the tests specified in table IV, in the order shown. Test data shall be reviewed as part of the complete verification of qualification.

MIL-C-39006C

TABLE IV. Group C inspection.

Test	Requirement paragraph	Test paragraph	Number of sample units to be inspected	Number of failures allowed ^{1/}
<u>Subgroup 1 (every 2 months)</u>				
Shock (specified pulse) - - - - -	3.11	4.7.7	} 12	}
Vibration, high frequency - - - - -	3.12	4.7.8		
Salt spray (corrosion)- - - - -	3.14	4.7.10		
<u>Subgroup 2 (every 2 months)</u>				
Solderability (axial-wire lead styles)- - -	3.15	4.7.11	} 12	} 1
Terminal strength - - - - -	3.16	4.7.12		
Surge voltage - - - - -	3.17	4.7.13		
Moisture resistance - - - - -	3.18	4.7.14		
Dielectric withstanding voltage (insulated styles)- - - - -	3.19	4.7.15		
Insulation resistance (insulated styles)- -	3.20	4.7.16		
Seal, condition C (hermetically sealed styles) - - - - -	3.10	4.7.6.2		
<u>Subgroup 3 (every 2 months)</u>				
Reverse voltage (when specified, see 3.1) -	3.23	4.7.19	12	1
<u>Subgroup 4 (every 12 months)</u>				
AC ripple life at 85°C (CLR79 only) - - - -	3.25	4.7.21	32 ^{2/}	1
<u>Subgroup 5 (every 2 months)</u>				
Low temperature (storage) - - - - -	3.21	4.7.17	} 12	} 1
Terminal strength (twist test, CLR65, nonhermetically-sealed) - - - - -	3.16	4.7.12.4		
<u>Subgroup 6 (every 12 months)</u>				
Vacuum life (hermetically-sealed styles, except CLR10, 14, 17, and 79) - - - - -	3.26	4.7.22	12	1
<u>Subgroup 7 (every 12 months)</u>				
Resistance to solvents- - - - -	3.30	4.7.26	} 6	} 1
Resistance to soldering heat- - - - -	3.31	4.7.27		
Barometric pressure (reduced) - - - - -	3.28	4.7.24		
<u>Subgroup 8 (CLR79 only) (every 12 months)</u>				
Thermal shock - - - - -	3.13	4.7.9	24 ^{3/}	1

^{1/} A sample having one or more defects shall be considered as a single failure.

^{2/} 32 units, 8 of each case size.

^{3/} 24 units, 6 of each case size.

MIL-C-39006C

4.6.2.1.1 Sampling plan. Sample units shall be taken from production every 2 months for subgroups 1, 2, 3, and 5, and every 12 months for subgroups 4, 6, 7, and 8. Except for subgroup 6, the voltages selected shall be represented in the sample in the same proportion as the voltages produced during the sampling period. The maximum and minimum case sizes manufactured during the sampling period shall also be represented in the sample in at least the approximate ratio of production. For subgroup 6, six samples shall be the smallest case size and six samples shall be the largest case size produced during that 12-month period.

4.6.2.1.2 Failures. If the number of failures exceeds the number allowed in table IV, the sample shall be considered to have failed.

4.6.2.1.3 Disposition of sample units. Sample units which have been subjected to group C inspection shall not be delivered on the contract or order.

4.6.2.1.4 Noncompliance. If a sample fails to pass group C inspection, the manufacturer shall take corrective action on the materials or processes, or both, as warranted, and on all units of product which can be corrected and which were manufactured under essentially the same conditions, with essentially the same materials, processes, etc., and which are considered subject to the same failure. Acceptance of the product shall be discontinued until corrective action, acceptable to the Government, has been taken. After the corrective action has been taken, group C inspection shall be repeated on additional sample units (all inspection, or the inspection which the original sample failed, at the option of the Government). Group A and B inspections may be reinstated; however, final acceptance shall be withheld until the group C reinspection has shown that the corrective action was successful. In the event of failure after reinspection, information concerning the failure and corrective action taken shall be furnished to the cognizant inspection activity and the qualifying activity.

4.6.3 Inspection of packaging. Sample packages and packs shall be selected and inspected in accordance with MIL-C-39028 to verify conformance with the requirements in section 5 of this specification.

4.7 Methods of examination and test.

4.7.1 Visual and mechanical examination. Capacitors shall be examined to verify that the materials, design, construction, physical dimensions, marking, and workmanship are in accordance with the applicable requirements (see 3.1, 3.4, 3.5, 3.32, and 3.33).

CAUTION: CARE SHOULD BE USED IN OPENING AND HANDLING THESE CAPACITORS DURING THE INTERNAL EXAMINATION SINCE SOME OF THE ELECTROLYTES USED ARE DANGEROUS AND MAY CAUSE HARM TO PERSON OR PROPERTY (EQUIPMENT).

4.7.2 Constant voltage conditioning (see 3.6). Capacitors shall be conditioned at 85°C with the applicable rated voltage applied through a 1,000 \pm 100-ohm resistor for a period of 48 $\begin{smallmatrix} +5 \\ -0 \end{smallmatrix}$ hours. Capacitors shall be returned to room ambient temperature and shall then be visually examined for mechanical damage and leakage of electrolyte.

NOTE: For nonpolarized capacitors, the conditioning voltage shall be reversed periodically so that the time of application of applicable voltages in both directions is approximately equal.

4.7.3 DC leakage (see 3.7). DC leakage shall be measured with the dc rated voltage applied. The electrification period shall be as follows:

- a. For qualification inspection - 5 \pm 1/2 minutes.
- b. For quality conformance inspection - Within 5 minutes.

For nonpolarized capacitors, measurements shall be made in both directions.

NOTE: DC leakage shall always be the first measurement when dc leakage, capacitance, and dissipation factor measurements are made concurrently.

MIL-C-39006C

4.7.4 Capacitance (see 3.8). Capacitors shall be tested in accordance with method 305 of MIL-STD-202. The following details shall apply:

- a. Test frequency - As specified in 4.3.2.1.
- b. Limit of accuracy - Within ± 2 percent.
- c. Magnitude of polarizing voltage - As specified in 4.3.2.1.

4.7.5 Dissipation factor (see 3.9). The dissipation factor shall be determined by a polarized bridge. Measurement accuracy shall be within ± 2 percent.

4.7.6 Seal (hermetically-sealed capacitors only, see 3.1) (see 3.10). Capacitors shall be tested in accordance with method 112 of MIL-STD-202. When applicable, this test may be performed prior to the addition of the sleeving.

4.7.6.1 Test-condition A. Capacitors shall be tested in accordance with test-condition A. No measurement is required after testing.

4.7.6.2 Test-condition C. Capacitors shall be tested in accordance with test-condition C. The following details shall apply:

- a. Procedure number and degree of leakage-rate sensitivity - Procedure III, 10^{-8} atm cc/sec. Upon completion of this procedure, test-condition A shall be used for checking gross leaks.
- b. Measurements after test - Not applicable.

Following this test, capacitors shall be visually examined for evidence of leakage.

4.7.7 Shock (specified pulse) (see 3.11). Capacitors shall be tested in accordance with method 213 of MIL-STD-202. The following details and exception shall apply:

- a. Special mounting means - Styles CLR14, CLR17, and CLR53 capacitors shall be securely fastened by normal mounting means. Capacitors with axial-wire lead terminals shall be rigidly mounted on a mounting fixture by the body with their terminals secured to rigidly supported stud-terminals, so spaced that the length of each terminal from the capacitor is approximately 0.375 inch (9.53 mm) when measured from the edge of the supporting stud-terminal. Capacitor terminals shall be within 30 degrees of being parallel. When securing capacitor terminals, care shall be taken to avoid pinching the capacitor terminals.
- b. Test-condition letter - I (100G).
- c. Measurement and electrical loading during shock - DC rated voltage shall be applied to the capacitor during test. Observations shall be made to determine intermittent contact or arcing or open - or short-circuiting. Detecting equipment shall be sufficiently sensitive to detect any interruption of 0.5 ms or greater duration.
- d. Examination after test - Capacitors shall be visually examined for evidence of arcing, breakdown, mechanical damage, and leakage of electrolyte.

4.7.8 Vibration, high frequency (see 3.12). Capacitors shall be tested in accordance with method 204 of MIL-STD-202. The following details and exception shall apply:

- a. Mounting of specimens - The body of the capacitor shall be rigidly mounted to the vibration-test apparatus.
- b. Test-condition letter - D (20G) or B (15G), as specified (see 3.1). The motion shall be applied for a total of 8 hours (4 hours in each of two mutually perpendicular directions, one parallel to and the other perpendicular to the cylindrical axis).

- c. Measurements - During the last 30 minutes of vibration in each direction, an electrical measurement shall be made on the capacitors to determine intermittent contacts or open- or short-circuiting. Detecting equipment shall be sufficiently sensitive to detect any interruption of 0.5 ms or greater duration. Capacitors shall be returned to the inspection conditions specified in 4.3.1, and the dc leakage, capacitance, and dissipation factor shall be measured as specified in 4.7.3, 4.7.4, and 4.7.5, respectively.
- d. Examination after test - Capacitors shall be visually examined for mechanical damage and leakage of electrolyte.

4.7.9 Thermal shock (see 3.13). Capacitors shall be tested in accordance with method 107 of MIL-STD-202. The following details and exceptions shall apply:

- a. Conditioning prior to first cycle - 15 minutes at room ambient conditions (see 4.3.1).
- b. Test-condition letter - A, except step 3 shall be $+125^{\circ} +4^{\circ}$ -0° C.
- c. Number of cycles - 30. CLR79 only, 300 cycles, qualification and group C; 30 cycles for group B.
- d. Measurements before cycling - Not applicable.
- e. Measurements after cycling - DC leakage, capacitance, and dissipation factor shall be measured as specified in 4.7.3, 4.7.4, and 4.7.5, respectively. In addition, capacitors shall be externally examined for leakage of electrolyte. Detection of leakage of electrolyte shall be determined by the use of Thymol blue, or other suitable chemical-indicator solution.

4.7.10 Salt spray (corrosion) (see 3.14). Capacitors shall be tested in accordance with method 101 of MIL-STD-202. The following details and exception shall apply:

- a. Applicable salt solution - 5 percent.
- b. Test-condition letter - B (48 hours).
- c. Measurements after test - Not applicable.
- d. Examination after test - After the test, the capacitors shall be washed and then air-dried for 24 hours. The capacitors shall then be examined for evidence of harmful corrosion, loss of plating, unwrapping of or mechanical damage to the insulating sleeving (when applicable), and legibility of marking.

4.7.11 Solderability (capacitors with axial-wire lead terminals only, see 3.1) (see 3.15). Capacitors shall be tested in accordance with method 208 of MIL-STD-202. The following details shall apply:

- a. Number of terminations of each part to be tested - 2.
- b. Depth of immersion - Terminals shall be immersed up to 0.062 inch (1.57 mm) of the welded joint or up to 0.156 inch (3.96 mm) of the body, whichever applies.

4.7.12 Terminal strength (see 3.16). All capacitors shall be tested in accordance with 4.7.12.1 and capacitors with solder-lug terminals which show visible bending during the pull test shall be tested in accordance with 4.7.12.2; capacitors with axial-wire lead terminals shall be tested in accordance with 4.7.12.3; and style CLR65 nonhermetically-sealed units shall be tested in accordance with 4.7.12.4. After the tests, the terminals, terminal weld or solder, and seals shall be examined for loosening or permanent damage.

MIL-C-39006C

4.7.12.1 Pull test. Capacitors shall be tested in accordance with method 211 of MIL-STD-202. The following details and exception shall apply:

- a. Test-condition letter - A.
- b. Applied force - 3 pounds $\begin{matrix} +2 \\ -0 \end{matrix}$ ounces for capacitors with axial wire-lead terminals and 5 pounds $\begin{matrix} +3 \\ -0 \end{matrix}$ ounces for capacitors with solder-lug terminals.
- c. Duration of applied force - 30 $\begin{matrix} +5 \\ -0 \end{matrix}$ seconds.

4.7.12.2 Bend test. Capacitors shall be tested in accordance with method 211 of MIL-STD-202. The following detail and exception shall apply:

- a. Test-condition letter - B.
- b. Number of bends - 4.

4.7.12.3 Wire-lead bend test. The terminal shall be inserted into the hole of the test block fixture and the wingnut shall be tightened (see figure 1). There shall be a minimum of 0.188 inch (4.78 mm) but not more than 0.313 inch (7.95 mm) of terminal length between the test block fixture and the end of the case (for terminals with welds more than 0.188 inch (4.78 mm) from the end of the case, the bottom of the weld shall be flush with the test block fixture). With the fixture firmly supported in a horizontal position, the case shall be forced over in such a manner that the terminal (from the end of the case of fixture) is maintained in its axial position as closely as practicable while bending the terminal until the end of the case touches the top surface of the fixture. When the case is returned to the starting position, one complete bend of the test will have been completed. The second bend shall be completed in the same manner as the first except that it shall be in the reverse direction. Succeeding bends shall alternate in direction similar to the first and second bends. All terminals shall be subjected to four bends. The rate of bend shall be approximately 5 seconds per bend.

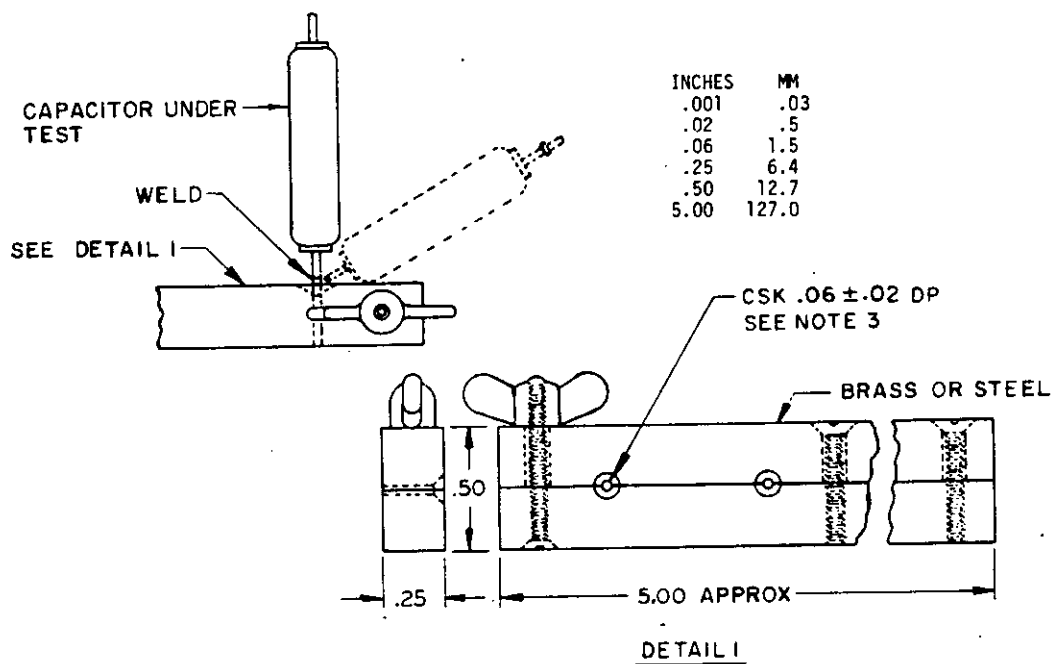

NOTES:

1. Dimensions are in inches.
2. Metric equivalents are given for general information only and are based upon 1.00 inch = 25.4 mm.
3. The diameter of the hole shall be .001 inch less than the diameter of the lead wire (see 3.1).

FIGURE 1. Test block fixture for wire-lead bend test.

4.7.12.4 Twist test (style CLR65, nonhermetically-sealed only). Capacitors shall be tested in accordance with method 211 of MIL-STD-202. The following detail and exceptions shall apply:

- a. Test-condition letter - D.
- b. Application of torsion - Rotate through 180 degrees.
- c. Examination after test - Capacitors shall be externally examined for leakage of electrolyte. Detection of leakage of electrolyte shall be determined by the use of Thymol blue, or other suitable chemical-indicator solution.

4.7.13 Surge voltage (see 3.17). Capacitors shall be subjected to 1,000 cycles of the applicable dc surge voltage specified (see 3.1). The ambient temperature during cycling shall be 85°C. Each cycle shall consist of a 30-second surge voltage application followed by a 5-1/2 minute discharge period. Voltage application shall be made through a resistance of 1,000 \pm 100 ohms including the source in series with the capacitor and the voltage source. Each surge voltage cycle shall be performed in such a manner that the capacitor is discharged through the 1,000-ohm resistor at the end of the 30-second application. The test shall be terminated on the discharge portion of the cycle. During the test, an electrical measurement shall be made to detect intermittent contacts and open- and short-circuiting. After the test, capacitors shall be visually examined for mechanical damage and leakage of electrolyte.

4.7.14 Moisture resistance (see 3.18). Capacitors shall be tested in accordance with method 106 of MIL-STD-202. The following details and exceptions shall apply:

- a. Mounting - Except during examination and measurements, capacitors shall be securely fastened by normal mounting means.
- b. Polarization and loading voltages - 6 volts dc.
- c. Step 7b - Vibration is not required during step 7b.
- d. Final measurements - After the final cycle and within 2 to 6 hours after removal of the capacitors from the humidity chamber, the dc leakage, capacitance, and dissipation factor shall be measured as specified in 4.7.3, 4.7.4, and 4.7.5, respectively, at the inspection conditions specified in 4.3.1.
- e. Examination after test - Capacitors shall be visually examined for evidence of harmful corrosion, mechanical damage, obliteration of marking, and leakage of electrolyte.

4.7.15 Dielectric withstanding voltage (insulated capacitors only, see 3.1) (see 3.19). Capacitors shall be tested in accordance with method 301 of MIL-STD-202. The following details and exception shall apply:

- a. Magnitude and nature of test voltage - 2,000 Vdc.
- b. Points of application of test voltage - Between the capacitor case and a V-block in intimate contact with the sleeving.
- c. Examination after test - Sleeving shall be examined for evidence of breakdown.

MIL-C-39006C

4.7.16 Insulation resistance (insulated capacitors only, see 3.1) (see 3.20). Capacitors shall be tested in accordance with method 302 of MIL-STD-202. The following details shall apply:

- a. Test-condition letter - B (500 Vdc $\pm 10\%$).
- b. Points of measurement - Between the capacitor case and a V-block in intimate contact with the sleeving.
- c. Electrification time - 1 minute $\begin{matrix} +0 \\ -15 \end{matrix}$ seconds.

4.7.17 Low temperature (storage) (see 3.21). Capacitors shall be tested in accordance with method 502 of MIL-STD-810. The following details and exceptions shall apply:

- a. Storage temperature - $-62^{\circ} \begin{matrix} +0 \\ -3 \end{matrix}$ C. CO₂ shall be used as a cooling agent.
- b. Exposure time - 72 hours followed by a 1-hour exposure at $+125^{\circ} \begin{matrix} +4 \\ -0 \end{matrix}$ C within 24 hours after low temperature storage.
- c. Measurements after exposure - Capacitors shall be returned to inspection conditions specified in 4.3.1 and within 24 hours after exposure, dc leakage, capacitance, and dissipation factor shall be measured as specified in 4.7.3, 4.7.4, and 4.7.5, respectively.
- d. Examination after test - Capacitors shall be externally examined for leakage of the electrolyte. Detection of leakage of electrolyte shall be determined by the use of Thymol blue, or other suitable chemical-indicator solution.

4.7.18 Stability at low and high temperatures (see 3.22). The measurements specified in table V shall be made in the order shown. The capacitors shall be brought to thermal stability. Thermal stability will have been reached when no further change in capacitance is observed between two successive measurements taken at 15-minute intervals.

4.7.18.1 Impedance. The capacitor shall be conditioned at $-55^{\circ} \begin{matrix} +0 \\ -3 \end{matrix}$ C for a period of not less than 30 minutes or until stable measurements can be obtained. The impedance shall then be measured directly or determined from measurements obtained on a bridge. Measurements shall be made at 120 ± 5 Hz. Measurement accuracy shall be within ± 5 percent.

4.7.19 Reverse voltage (when specified, see 3.1) (see 3.23). Capacitors shall be subjected to a dc potential of 3 volts, applied in the reverse polarity direction, for 125 ± 10 hours. The ambient temperature during the test shall be 85°C. Capacitors shall be maintained at 85°C and dc rated voltage shall be applied in the forward polarity direction for an additional period of 125 ± 10 hours. Capacitors shall then be returned to room ambient temperature and the dc leakage, capacitance, and dissipation factor shall be measured as specified in 4.7.3, 4.7.4, and 4.7.5, respectively.

4.7.20 Life at 85°C (see 3.24).

4.7.20.1 2,000-hour (qualification inspection) (see 3.24.1). Capacitors shall be tested in accordance with method 108 of MIL-STD-202. The following details and exceptions shall apply:

- a. Distance of temperature measurements from specimens, in inches - Not applicable.
- b. Method of mounting - Styles CLR14 and CLR17 capacitors shall be mounted by normal mounting means. Other style capacitors shall be mounted by their terminals.
- c. Test temperature and tolerance $85^{\circ} \begin{matrix} +3 \\ -0 \end{matrix}$ C.

- d. Operating conditions - DC rated voltage (see 3.1) shall be applied gradually (not to exceed 5 minutes either by a slow build-up of the voltage or through a resistor which shall be shorted out within 5 minutes). Voltage shall be applied continuously except for measurement periods. The impedance of the voltage source, as seen from the terminals of each capacitor, shall not exceed 10 ohms. Storage batteries, or an electronic power supply, capable of supplying at least 100 milliamperes when a capacitor is shorted out shall be used. For nonpolarized capacitors, the voltage shall be reversed every 125 ± 10 hours.
- e. Test-condition letter - F (2,000 $\begin{smallmatrix} +72 \\ -0 \end{smallmatrix}$ hours).
- f. Measurements during exposure (at 85°C) - DC leakage shall be measured as specified in 4.7.3, during the first hour of exposure and then at 240 $\begin{smallmatrix} +48 \\ -0 \end{smallmatrix}$, 1,000 $\begin{smallmatrix} +48 \\ -0 \end{smallmatrix}$, and 2,000 $\begin{smallmatrix} +72 \\ -0 \end{smallmatrix}$ hours.
- g. Measurements after exposure - Capacitors shall be returned to the inspection conditions specified in 4.3.1, and dc leakage, capacitance, and dissipation factor shall be measured as specified in 4.7.3, 4.7.4, and 4.7.5, respectively.
- h. Examination after test - Capacitors shall be visually examined for damage, obliteration of marking, and leakage of electrolyte.

TABLE V. Temperatures and measurements for stability tests at low and high temperatures.

Step	Temperature	Measurement	Test paragraph
1	+25°C	DC leakage Capacitance Dissipation factor	4.7.3 4.7.4 4.7.5
2	-55° $\begin{smallmatrix} +0 \\ -3 \end{smallmatrix}$ °C	Impedance Capacitance	4.7.18.1 4.7.4
3	+25°C	DC leakage Capacitance Dissipation factor	4.7.3 4.7.4 4.7.5
4	+85° $\begin{smallmatrix} +3 \\ -0 \end{smallmatrix}$ °C	DC leakage Capacitance Dissipation factor	4.7.3 4.7.4 4.7.5
5	+125° $\begin{smallmatrix} +4 \\ -0 \end{smallmatrix}$ °C	DC leakage ^{1/} Capacitance Dissipation factor	4.7.3 4.7.4 4.7.5
6	+25°C	DC leakage Capacitance Dissipation factor	4.7.3 4.7.4 4.7.5

1/ During this measurement, derated voltage (see 3.1) shall be applied.

MIL-C-39006C

4.7.20.2 10,000-hour (group B inspection) (see 3.24.2). Except as specified in the following, capacitors shall be tested as specified in 4.7.20.1:

- a. Test duration - 10,000 $\begin{smallmatrix} +96 \\ -0 \end{smallmatrix}$ hours.
- b. Measurements during exposure - DC leakage shall be measured during the first hour of exposure and then at 240 $\begin{smallmatrix} +48 \\ -0 \end{smallmatrix}$, 1,000 $\begin{smallmatrix} +48 \\ -0 \end{smallmatrix}$, 2,000 $\begin{smallmatrix} +72 \\ -0 \end{smallmatrix}$, and every 2,000 $\begin{smallmatrix} +72 \\ -0 \end{smallmatrix}$ hours thereafter until 10,000 $\begin{smallmatrix} +96 \\ -0 \end{smallmatrix}$ hours have elapsed. At the completion of 6,000 hours, capacitors shall be returned to the inspection conditions specified in 4.3.1, and dc leakage, capacitance, and dissipation factor shall be measured as specified in 4.7.3, 4.7.4, and 4.7.5, respectively.
- c. Measurements after exposure - In addition to the measurements specified in 4.7.20.1g, the dielectric withstanding voltage and insulation resistance shall be measured on insulated capacitors as specified in 4.7.15 and 4.7.16, respectively.

4.7.20.3 Extended life (see 3.24.2).

4.7.20.3.1 Following 2,000-hour qualification inspection. Sample units which have been subjected to 2,000 hours of life test as specified in 4.7.20.1, shall remain on test for an additional 8,000 $\begin{smallmatrix} +96 \\ -0 \end{smallmatrix}$ hours. DC leakage shall be measured during exposure after every 2,000 $\begin{smallmatrix} +72 \\ -0 \end{smallmatrix}$ hours until 10,000 $\begin{smallmatrix} +96 \\ -0 \end{smallmatrix}$ hours have elapsed. After completion of the 10,000-hour life test time, the dielectric withstanding voltage and insulation resistance shall be measured on insulated capacitors as specified in 4.7.15 and 4.7.16, respectively.

4.7.21 AC ripple life at 85°C (qualification and group C inspection) (CLR79 only) (see 3.25). Capacitors shall be tested in accordance with method 108 of MIL-STD-202. The following details and exceptions shall apply:

- a. Distance of temperature measurements from specimens, in inches - Not applicable.
- b. Method of mounting - Capacitors shall be mounted by normal mounting means.
- c. Test temperature - 85° $\begin{smallmatrix} +3 \\ -0 \end{smallmatrix}$ °C.
- d. Operating conditions - DC rated voltage (see 3.1) shall be applied gradually (not to exceed 5 minutes either by a slow build-up of the voltage or through a resistor which shall be shorted out within 5 minutes). The rated ripple current at 40 \pm 2 kHz (see 3.1) shall also be applied. The impedance of the voltage source, as seen from the terminals of each capacitor, shall not exceed 10 ohms. Storage batteries, or an electronic power supply, capable of supplying at least 100 milliamperes when a capacitor is shorted out shall be used.
- e. Test-condition letter - F (2,000 $\begin{smallmatrix} +72 \\ -0 \end{smallmatrix}$ hours).
- f. Measurements before and after exposure - DC leakage, capacitance, and dissipation factor shall be measured as specified in 4.7.3, 4.7.4, and 4.7.5, respectively.
- g. Examination after test - Capacitors shall be visually examined for damage, obliteration of marking, and leakage of electrolyte.

MIL-C-39006C

4.7.22 Vacuum life (hermetically-sealed capacitors only, except CLR10, CLR14, CLR17, and CLR79, see 3.1) (see 3.26). Insulating sleeving shall be removed and capacitors shall be conditioned at 85°C for a period of 50 hours maximum. Capacitors shall then be returned to the inspection conditions specified in 4.3.1 and each capacitor shall be weighed individually. Atmospheric pressure shall be reduced to 1×10^{-6} mm (± 10 percent) and capacitors shall be tested as specified in 4.7.20.1a to 4.7.20.1d inclusive. Test duration shall be $500 \begin{smallmatrix} +48 \\ -0 \end{smallmatrix}$ hours. Capacitors shall then be returned to the inspection conditions specified in 4.3.1 and dc leakage, capacitance, and dissipation factor shall be measured as specified in 4.7.3, 4.7.4, and 4.7.5, respectively. Following these measurements, each capacitor shall be weighed individually. Weight measurement accuracy shall be ± 0.05 milligram.

4.7.23 Life at 125°C (see 3.27). Except as specified in the following, capacitors shall be tested as specified in 4.7.20.1:

- a. Test temperature and tolerance - $125 \begin{smallmatrix} +4 \\ -0 \end{smallmatrix}$ ° C.
- b. Operating conditions - Derated voltage (see 3.1) shall be applied.
- c. Measurements after exposure - In addition to the measurements specified in 4.7.20.1g, the dielectric withstanding voltage and insulation resistance shall be measured on insulated capacitors as specified in 4.7.15 and 4.7.16, respectively.

4.7.23.1 10,000-hour (group B inspection) (see 3.27.1). Except as specified in the following, capacitors shall be tested as specified in 4.7.23:

- a. Test duration - $10,000 \begin{smallmatrix} +96 \\ -0 \end{smallmatrix}$ hours.
- b. Measurements during exposure - DC leakage shall be measured during the first hour of exposure and then at $240 \begin{smallmatrix} +48 \\ -0 \end{smallmatrix}$, $1,000 \begin{smallmatrix} +48 \\ -0 \end{smallmatrix}$, $2,000 \begin{smallmatrix} +72 \\ -0 \end{smallmatrix}$, and every $2,000 \begin{smallmatrix} +72 \\ -0 \end{smallmatrix}$ hours thereafter until $10,000 \begin{smallmatrix} +96 \\ -0 \end{smallmatrix}$ hours have elapsed.
- c. Measurements after exposure - In addition to the measurements specified in 4.7.23c, the dc leakage, capacitance, and dissipation factor, dielectric withstanding voltage and insulation resistance shall be measured as specified in 4.7.3, 4.7.4, 4.7.5, 4.7.15, and 4.7.16, respectively.

4.7.24 Barometric pressure (reduced) (see 3.28). Capacitors shall be tested in accordance with method 105 of MIL-STD-202. The following details shall apply:

- a. Method of mounting - By normal mounting means.
- b. Test-condition letter - E (150,000 ft).
- c. Test during subjection to reduced pressure - At the end of the conditioning period and with the capacitors still at reduced pressure, the specified voltage (see 3.1) shall be applied for 1 minute ± 5 seconds.
- d. Test after subjection to reduced pressure - Capacitors shall be visually examined for harmful deformation of the case, mechanical damage, obliteration of marking, leakage of electrolyte, and indications of flashover and breakdown.
- e. Exposure time prior to measurements - 5 minutes (minimum).

4.7.25 Fungus (see 3.29). Capacitors shall be tested in accordance with method 508 of MIL-STD-810. Pretest and post-test measurements are not required.

MIL-C-39006C

4.7.26 Resistance to solvents (see 3.30). Capacitors shall be tested in accordance with method 215 of MIL-STD-202. The following details shall apply:

- a. Portion of specimen to be brushed - That portion on which marking is present.
- b. Number of specimens to be tested - As specified in applicable inspection tables.
- c. Permissible extent of damage - As specified in 3.30.

4.7.27 Resistance to soldering heat (see 3.31). Capacitors shall be tested in accordance with method 210 of MIL-STD-202. The following details and exceptions shall apply:

- a. Depth of immersion - Within 0.250-inch of the seal or case.
- b. Test-condition letter - B (260° ±5°C; 10 ±1 seconds).
- c. Cooling time prior to final measurements - 10 ±1 minutes.
- d. Measurements after test - DC leakage, capacitance, and dissipation factor shall be measured as specified in 4.7.3, 4.7.4, and 4.7.5, respectively.

5. PACKAGING

(The packaging requirements specified herein apply only for direct Government procurements. Packaging requirements of referenced documents listed in Section 2 do not apply unless specifically stated in the contract or order. Packaging requirements for products procured by contractors shall be specified in the individual order.)

5.1 In addition to the marking requirements specified in MIL-C-39028, capacitors shall be packaged in accordance with MIL-C-39028. (See 6.1.1.)

6. NOTES

6.1 Intended use. These capacitors are primarily intended for use in filter, by-pass, and energy storage applications requiring large capacitance values but where close tolerances are not an important factor and where the ac component of voltage is small compared to the dc rated voltage.

6.1.1 Application of packaging

6.1.1.1 Shipments to Government activities. The packaging requirements of this specification are primarily intended for the preparation of capacitors for shipment to Government activities.

6.1.1.2 Shipments of ER capacitors to Government contractors and manufacturers' distributors. Federal Standard No. 356, Commercial Packaging of Supplies and Equipment, should be specified for the packaging of ER capacitors shipped to Government contractors and subcontractors and to category A and B distributors as defined in MIL-STD-790. The marking of the unit containers should not be required provided the intermediate containers are marked.

6.2 Ordering data. Procurement documents should specify the following:

- a. Title, number, and date of this specification.
- b. Title, number, and date of the applicable specification sheet, and the complete part number (see 3.1).
- c. If remarking of parts is required to indicate FR level (see 3.32.3).
- d. Required levels of preservation and packaging and packing, and special marking (see section 5).

6.3 Qualification.^{2/} With respect to products requiring qualification, awards will be made only for products which are at the time set for opening of bids, qualified for inclusion in the applicable *qualified products list*, whether or not such products have actually been so listed by that date. The attention of the suppliers is called to this requirement, and manufacturers are urged to arrange to have the products that they propose to offer to the Federal Government tested for qualification in order that they may be eligible to be awarded contracts or orders for the products covered by this specification. The activity responsible for the qualified products list is the Naval Electronics Systems Command, Department of the Navy, Washington, D.C. 20360. Information pertaining to qualification of products may be obtained from either the Naval Electronic Systems Command or the Defense Electronics Supply Center (DESC), Dayton, Ohio 45444, agent for the administration of the Qualified Products List.

6.4 Application information.

6.4.1 Life degradation. The degradation limits change with duration of life test. The FR levels are based on catastrophic failures and parameter drifts *beyond the degradation limits*.

6.4.2 Ripple voltage. The peak of the applied ac ripple voltage plus the applied dc voltage must not exceed the dc voltage rating of the capacitor either forward or reverse.

6.4.3 Paralleling capacitors. If capacitors are to be paralleled, the capacitance values should be equal and the ripple current through each should be within 20 percent of each other.

6.4.4 Application information for styles CLR10, CLR14, and CLR17.

6.4.4.1 Thermal shock. When these styles, in application, are not subjected to more than five cycles (see 4.7.9), they may be operated up to 175°C when properly voltage derated (see figure 2).

6.4.4.2 Ripple current. The maximum allowable rms ripple current (in milliamperes) is shown in table VI. The values are for 120-Hz operation over rated temperature (-55° to +125°C).

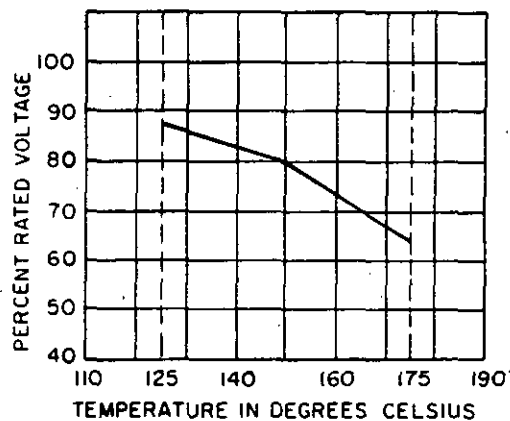

FIGURE 2. Voltage derating with temperature (125° to 175° C)
(styles CLR10, CLR14, and CLR17 only).

^{2/} SD-6, "Provisions Governing Qualification," is issued for the information of applicants requesting qualification of products. Copies of this publication may be obtained from the Commanding Officer, Naval Publications and Forms Center, 5801 Tabor Avenue, Philadelphia, Pennsylvania 19120.

MIL-C-39006C

TABLE VI. Maximum ripple current.

Style	Rated voltage (85° C)	Capacitance value	Ripple current	Style	Rated voltage (85° C)	Capacitance value	Ripple current
CLR10	Volts, dc	μ F	mA	CLR14	Volts, dc	μ F	mA
	8	70.0	137		450	5.0	252
	8	140.0	213		450	10.0	308
	10	50.0	137		540	4.0	250
	10	100.0	213		540	8.0	308
	20	28.0	137		630	3.5	250
	20	56.0	213	630	7.0	308	
	30	20.0	137	CLR17	30	370.0	550
	30	40.0	213		30	650.0	694
	60	12.0	137		30	1300.0	694
	60	25.0	213		60	200.0	550
	90	8.0	137		60	350.0	694
	90	16.0	213		60	700.0	694
	180	4.0	117		90	120.0	550
	180	8.0	186		90	220.0	694
	270	2.5	112		90	450.0	694
270	5.0	179	180		42.0	363	
360	2.0	108	180	60.0	363		
360	4.0	175	180	110.0	631		
CLR14	20	100.0	333	180	230.0	631	
	20	200.0	375	270	28.0	339	
	30	75.0	333	270	40.0	339	
	30	150.0	375	270	75.0	608	
	60	40.0	333	270	150.0	608	
	60	80.0	375	360	22.0	323	
	90	25.0	333	360	30.0	323	
	90	50.0	375	450	17.0	315	
	180	12.0	282	450	25.0	315	
	180	25.0	341	540	14.0	309	
	270	8.0	266	540	20.0	309	
	270	16.0	320	630	12.0	306	
360	6.0	258	630	18.0	306		
360	12.0	314					

For frequencies other than 120 Hz, the 120 Hz-ripple value should be multiplied by the correction factor as shown in figure 3.

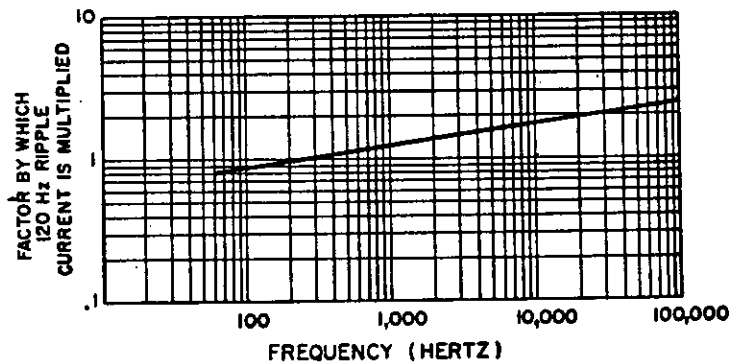

NOTE: A polarizing voltage must be applied to the capacitor which on negative alternations of the ripple voltage will preclude polarity reversal and on positive alternations will not cause the capacitor rated voltage to be exceeded.

FIGURE 3. Ripple current correction factors (styles CLR10, CLR14, and CLR17 only).

MIL-C-39006C

6.5 Selection and use information. Equipment designers should refer to MIL-STD-198, "Capacitors, Selection and Use of," for a selection of standard capacitor types and values for new equipment design. Additional application and use information concerning these capacitors are also provided in MIL-STD-198.

6.6 Substitutability data. For a cross reference of the substitutability relationship of superseded styles, see the applicable specification sheet (see 3.1).

6.7 Hermetic seal. For the purpose of this specification, a hermetically-sealed capacitor is one in which the capacitive element is contained within a sealed metal enclosure (see 3.5.1), where sealing is accomplished by material fusion, welding, brazing, or soldering to glass.

6.8 Changes from previous issue. Asterisks are not used in this revision to identify changes with respect to the previous issue, due to the extensiveness of the changes.

Custodians:

Army - ER
Navy - EC
Air Force - 11
NASA - NA

Review activities:

Army - AR
Navy - SH
Air Force - 17, 85, 99
DLA - ES

User activities:

Navy - AS, MC, OS
Air Force - 19

Preparing activity:

Navy - EC

Agent:

DLA - ES

(Project 5910-1244)

APPENDIX

PROCEDURE FOR QUALIFICATION INSPECTION

10. SCOPE

10.1 This appendix details the procedure for submission of samples, with related data, for qualification inspection of capacitors covered by this specification.

20. SUBMISSION

20.1 Sample. For qualification to FR level L or M (see 3.1) as per table I.

20.1.1 Single-type submission. A sample consisting of the following quantities shall be submitted for each style, dc rated voltage, capacitance tolerance, and electrolyte for which qualification is sought:

For styles CLR71 and 73 (nonhermetic seal) - - - - - 192 sample units each.

For styles CLR25, 27, 35, 37, 65, and 69 (hermetic seal)- - - 198 sample units each.

For styles CLR10, 14, and 17 (hermetic seal)- - - - - 125 sample units each.

For style CLR78 (hermetic seal)- - - - - 235 sample units each.

20.1.2 Hermetic or nonhermetic voltage-group submission (see 3.1). A sample consisting of the quantities listed in 20.1.1 shall be equally divided between the highest capacitance value for the lowest dc rated voltage and the highest capacitance value for the highest dc rated voltage, within a single voltage group for which qualification is sought, shall be submitted.^{3/} The capacitance tolerance and electrolyte of the submitted sample units shall be the same. A separate submission shall be made for each voltage group in each style for which qualification is sought. Examples of voltage-group capacitor submissions are listed in table VII.

20.2 Test data. When examinations and tests are to be performed at a Government laboratory, prior to submission, all sample units shall be subjected to the examinations and tests indicated as nondestructive in table I. Each submission shall be accompanied by the test data obtained from these examinations and tests. The performance of the destructive examinations and tests by the manufacturer on a duplicate set of sample units is encouraged, although not required. All test data shall be submitted in duplicate.

20.3 Certification of material. When submitting samples for qualification, the manufacturer shall submit certification, in duplicate, that the materials used in his components are in accordance with the applicable specification requirements.

20.4 Description of items. The manufacturer shall submit a detailed description of the capacitors being submitted for inspection, including, as applicable, information on the type of electrolyte, the case and lead materials, the sleeving material, type of welds or solder buttons, and the case finish.

30. EXTENT OF QUALIFICATION

30.1 Single-type submission.

^{3/} For style CLR65, voltage group II, low capacitance series, the highest capacitance value in the group shall be submitted.

MIL-C-39006C

TABLE VII. Examples of hermetic or nonhermetic voltage-group submission for "L" FR level.

Style	Seal type	Part number of capacitors to be submitted	Number of sample units	Rated voltage
				Volts, dc
CLR10	Hermetic	M39006/18-1001	63	8
		-1011	63	90
		-1013	63	180
		-1017	63	360
CLR14	Hermetic	M39006/19-1001	63	20
		-1007	63	90
		-1009	63	180
		-1013	63	360
		-1015	63	450
		-1019	63	630
CLR17	Hermetic	M39006/20-1004	63	30
		-1016	63	90
		-1024	63	180
		-1036	63	360
		-1040	63	450
		-1048	63	630
CLR25	Hermetic	M39006/01-3004	99	15
		-3025	99	100
		-3029	198	150
CLR27	Hermetic	M39006/02-1203	99	15
		-1223	99	100
		-1227	198	150
CLR35	Hermetic	M39006/03-1303	99	15
		-1316	99	50
		-1320	99	75
		-1332	99	200
		-1336	99	250
		-1348	99	450
CLR37	Hermetic	M39006/04-1203	99	15
		-1215	99	50
		-1219	99	75
		-1232	99	200
		-1236	99	250
		-1244	99	375
CLR65 (high-capacitance series) ^{1/}	Hermetic	M39006/09-8020	99	6
		-8074	99	15
		-8088	99	25
		-8168	99	75
		-8188	99	100
		-9028	99	125
CLR65 (low-capacitance series)	Hermetic	M39006/09-8015	99	6
		-8069	99	15
		-8183	99	100
		-8203	99	125
CLR69	Hermetic	M39006/21-0008	99	6
		-0032	99	15
		-0056	99	50
		-0080	99	100
		-0088	99	125
CLR71	Non-hermetic	M39006/16-1004	96	15
		-1029	96	100
		-1034	192	150
CLR73	Non-hermetic	M39006/17-1004	96	15
		-1029	96	100
		-1034	192	150

^{1/} Qualification of the high-capacitance series may be the basis for qualification of the low-capacitance series of the same voltage group.

MIL-C-39006C

30.1.1 Capacitors. Qualification of capacitance values will be restricted to values equal to and less than the capacitance value in the style, voltage, and electrolyte submitted. Capacitance-tolerance qualification will be restricted to the capacitance tolerances equal to and wider than the tolerance submitted.

30.2 Voltage-group submission. Qualification of the types submitted will be the basis for qualification of all intermediate voltages of the voltage group submitted, provided that the style and the electrolyte are the same. Capacitance-range qualification for each voltage submitted will be restricted to the capacitance values equal to and less than the capacitance value submitted. For intermediate and lower voltages in the same voltage group, capacitance-range qualification will be restricted to capacitance values equal to and less than the higher capacitance value submitted. Capacitance-tolerance qualification will be restricted to the capacitance tolerances equal to and wider than the tolerance submitted.

40. QUALIFICATION APPROVAL FOR LOWER FR LEVELS

40.1 Extension of qualification to lower FR levels shall be in accordance with 4.4.4 of this specification.

U.S. GOVERNMENT PRINTING OFFICE: 1978 - 603-022/5367

INSTRUCTIONS: In a continuing effort to make our standardization documents better, the DoD provides this form for use in submitting comments and suggestions for improvements. All users of military standardization documents are invited to provide suggestions. This form may be detached, folded along the lines indicated, taped along the loose edge (*DO NOT STAPLE*), and mailed. In block 5, be as specific as possible about particular problem areas such as wording which required interpretation, was too rigid, restrictive, loose, ambiguous, or was incompatible, and give proposed wording changes which would alleviate the problems. Enter in block 6 any remarks not related to a specific paragraph of the document. If block 7 is filled out, an acknowledgement will be mailed to you within 30 days to let you know that your comments were received and are being considered.

NOTE: This form may not be used to request copies of documents, nor to request waivers, deviations, or clarification of specification requirements on current contracts. Comments submitted on this form do not constitute or imply authorization to waive any portion of the referenced document(s) or to amend contractual requirements.

(Fold along this line)

(Fold along this line)

DEPARTMENT OF THE NAVY



NO POSTAGE
NECESSARY
IF MAILED
IN THE
UNITED STATES

OFFICIAL BUSINESS
PENALTY FOR PRIVATE USE \$300

BUSINESS REPLY MAIL
FIRST CLASS PERMIT NO. 12503 WASHINGTON D. C.

POSTAGE WILL BE PAID BY THE DEPARTMENT OF THE NAVY

COMMANDER
NAVAL ELECTRONIC SYSTEMS COMMAND (ELEX 8111)
WASHINGTON, DC 20360

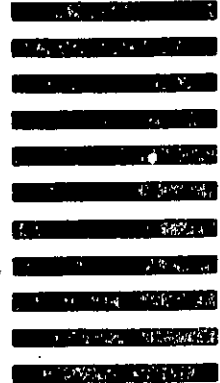

STANDARDIZATION DOCUMENT IMPROVEMENT PROPOSAL

(See Instructions – Reverse Side)

1. DOCUMENT NUMBER	2. DOCUMENT TITLE
3a. NAME OF SUBMITTING ORGANIZATION	4. TYPE OF ORGANIZATION (Mark one) <input type="checkbox"/> VENDOR <input type="checkbox"/> USER <input type="checkbox"/> MANUFACTURER <input type="checkbox"/> OTHER (Specify): _____
b. ADDRESS (Street, City, State, ZIP Code)	
5. PROBLEM AREAS	
a. Paragraph Number and Wording:	
b. Recommended Wording:	
c. Reason/Rationale for Recommendation:	
6. REMARKS	
7a. NAME OF SUBMITTER (Last, First, MI) – Optional	b. WORK TELEPHONE NUMBER (Include Area Code) – Optional
c. MAILING ADDRESS (Street, City, State, ZIP Code) – Optional	8. DATE OF SUBMISSION (YYMMDD)