

INCH-POUND  
MIL-C-25F  
5 October 2010  
SUPERSEDING  
MIL-C-25E  
12 January 2004

## MILITARY SPECIFICATION

### CAPACITORS, FIXED, PAPER OR PLASTIC DIELECTRIC, DIRECT CURRENT, (HERMETICALLY SEALED IN METAL CASES), GENERAL SPECIFICATION FOR

This specification is approved for use by all Departments  
and Agencies of the Department of Defense.

INACTIVE FOR NEW DESIGN  
after 21 June 1968

#### 1. SCOPE

1.1 Scope. This specification covers the general requirements for direct-current (dc) paper-dielectric, fixed capacitors hermetically sealed in metal cases, intended primarily for filter, by-pass, and blocking purposes where the alternating-current (ac) component of the impressed voltage is small with respect to the dc voltage rating.

#### 1.2 Classification.

1.2.1 Part or Identifying Number (PIN). Capacitors specified herein (see 3.1); are identified by a PIN that is in the following form, and as specified (see 3.1 and 6.1):

CP53	B	1	E	B	105	K	1
Style	Terminal	Circuit	Characteristic	Voltage	Capacitance	Capacitance tolerance	Vibration grade
(1.2.1.1)	(1.2.1.2)	(1.2.1.3)	(1.2.1.4)	(1.2.1.5)	(1.2.1.6)	(1.2.1.7)	(1.2.1.8)

1.2.1.1 Style. The style is identified by the two-letter symbol "CP" followed by a two-digit number; the letters identify direct-current, paper-dielectric, fixed capacitors hermetically sealed in metal cases; the first digit identifies general shape of the case, and the second digit identifies specific details other than case size. Each style designation includes a family of case sizes.

1.2.1.2 Terminal. The only terminal still available is a solder lug (nonremovable), identified by the letter "B".

1.2.1.3 Circuit. The circuit diagram and the number of terminals associated with it are identified by a single symbol as shown in [table I](#).

Comments, suggestions, or questions on this document should be addressed to: DLA Land and Maritime, ATTN: VAT, Post Office Box 3990, Columbus, OH 43218-3990, or emailed to [capacitorfilter@dla.mil](mailto:capacitorfilter@dla.mil). Since contact information can change, you may want to verify the currency of this address information using the ASSIST Online database at <https://assist.daps.dla.mil>.

## MIL-C-25F

TABLE I. Circuit diagram and number of terminals.

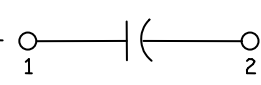
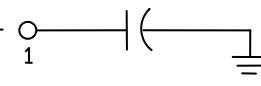
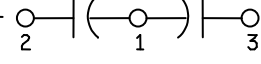
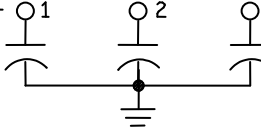
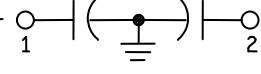
Circuit diagram	Number of terminals
SYMBOL 1----- 	2
SYMBOL 2----- 	1
SYMBOL 4----- 	3
SYMBOL 5----- 	3
SYMBOL 6----- 	2

1.2.1.4 Characteristic. The characteristic is identified by a single letter in accordance with table II.

TABLE II. Characteristic.

Characteristic	Values of characteristics	
	E and F	K
High ambient test temperature, degrees centigrade $\pm 3^{\circ}\text{C}$	+85 $^{\circ}\text{C}$	+125 $^{\circ}\text{C}$
Low ambient test temperature, degrees centigrade $\pm 3^{\circ}\text{C}$	-55 $^{\circ}\text{C}$	-55 $^{\circ}\text{C}$
Life-test dc voltage in percent of the voltage rating at +40 $^{\circ}\text{C}$ (see 4.6.15): Watt-second group:		
I: 1A (0.08 watt-second and less)	140	140
1B (0.08 + to 0.5 watt-second)	140	120
II (0.5 + to 5 watt-seconds)	130	---
III (5 + to 50 watt-seconds)	110	---
IV (greater than 50 watt-seconds)	90	---

1.2.1.5 Voltage rating. The dc voltage rating for continuous operation at +40 $^{\circ}\text{C}$ , except for characteristic K, which is +85 $^{\circ}\text{C}$ , is identified by a single letter in accordance with table III (see 6.9).

TABLE III. DC voltage rating.

Symbol	DC voltage rating (volts)
B	100
C	200
E	400
F	600
G	1,000

1.2.1.6 Capacitance. The nominal capacitance value expressed in picofarads (pf) is identified by a three-digit number; the first two digits represent significant figures and the last digit specifies the number of zeros to follow.

## MIL-C-25F

1.2.1.7 Capacitance tolerance. The capacitance tolerance in percent is identified by a single letter in accordance with table IV.

TABLE IV. Capacitance tolerance.

Symbol	Capacitance tolerance (percent)
K	±10
V	+20, -10

1.2.1.8 Vibration grade. The only vibration grade still available is grade 1 (10 to 55Hz).

1.2.2 Voltage rating versus temperature. Capacitors of characteristic K have a dc voltage rating for continuous operation at +85°C, and capacitors of all other characteristics have a dc voltage rating for continuous operation at +40°C as specified (see 3.1). Voltage derating at other ambient temperatures may be necessary in order to realize equivalent life (see 3.1, 6.8, and 6.8.1).

The permissible operating voltages, while based on incomplete data, are the capacitor supplier's best estimate to provide a life expectancy of 8,800 hours of continuous operation at high ambient temperatures. Longer life can be expected of all types by operation at still lower voltages; for example, a life expectancy of approximately 44,000 hours may be obtained by operation at 70 percent of the voltage specified. Also a life longer than 8,800 hours may be expected at the voltage specified if the high temperature prevails for only a portion of the whole operating time.

1.2.2.1 AC component. The rating given is the steady-state dc voltage, or the sum of the dc voltage and the peak ac voltage, provided that the peak ac voltage does not exceed 20 percent of the rating at 60 Hertz (Hz), 15 percent at 120 Hz, or 1 percent at 10,000 Hz. Where heavy transient or pulse currents are encountered, the requirements of this specification are not sufficient to guarantee satisfactory performance and due allowance must be made, therefore, in the selection of a capacitor.

## 2. APPLICABLE DOCUMENTS

2.1 General. The documents listed in this section are specified in sections 3 and 4 of this specification. This section does not include documents cited in other sections of this specification or recommended for additional information or as examples. While every effort has been made to ensure the completeness of this list, document users are cautioned that they must meet all specified requirements documents cited in sections 3 and 4 of this specification, whether or not they are listed.

### 2.2 Government documents.

2.2.1 Specifications, standards, and handbooks. The following specifications, standards, and handbooks form a part of this document to the extent specified herein. Unless otherwise specified, the issues of these documents are those cited in the solicitation or contract (See 6.2).

#### DEPARTMENT OF DEFENSE SPECIFICATIONS

- [MIL-C-25/4](#) - Capacitor, Fixed, Paper (or Plastic) Dielectric, Direct Current, (Hermetically Sealed in Metallic Cases), Styles CP53, CP54 and CP55.
- [MIL-C-25/6](#) - Capacitor, Fixed, Paper-Dielectric, Direct Current, (Hermetically Sealed in Metallic Cases), Styles CP67 and CP69.

#### DEPARTMENT OF DEFENSE STANDARDS

- [MIL-STD-202](#) - Test Method Standard Electronic and Electrical Component Parts.

(Copies of these documents are available online at <https://assist.daps.dla.mil/quicksearch/> or from the Standardization Document Order Desk, 700 Robbins Avenue, Building 4D, Philadelphia, PA 19111-5094.)

## MIL-C-25F

2.3 Non-Government publications. The following documents form a part of this document to the extent specified herein. Unless otherwise specified, the issues of these documents are those cited in the solicitation or contract.

## AMERICAN SOCIETY FOR TESTING MATERIALS

| [ASTM D92](#) - Standard Test Method for Flash and Fire Points by Cleveland Open Cup Tester.

(Copies of this document may be ordered online at [www.astm.org](http://www.astm.org) or from the American Society for Testing Materials, 1916 Race Street, Philadelphia, PA 19103.)

| 2.4 Order of precedence. Unless otherwise specified herein or in the contract, in the event of a conflict between the text of this document and the references cited herein (except for related specification sheets), the text of this document takes precedence. Nothing in this document, however, supersedes applicable laws and regulations unless a specific exemption has been obtained.

## 3. REQUIREMENTS

3.1 Specification sheet. The individual item requirements shall be as specified herein and in accordance with the applicable specification sheet. In the event of any conflict between requirements of this specification and the specification sheet, the latter shall govern (see [6.2](#)).

3.2 Qualification. Capacitors furnished under this specification shall be products that are authorized by the qualifying activity for listing on the applicable qualified products list before contract award (see [4.4](#) and [6.3](#)).

3.3 Material. The material shall be as specified herein. However, when a definite material is not specified, a material shall be used which will enable the capacitors to meet the performance requirements of this specification. Acceptance or approval of any constituent material shall not be construed as a guaranty of the acceptance of the finished product.

3.3.1 Insulation, impregnating, and sealing compounds. Compounds used in the impregnation and filling of capacitors shall be chemically inactive with respect to the capacitor unit and the case (see [3.4.1](#), [6.11](#), and [6.12](#)). The compounds, either in the state of original application or as a result of having aged, shall have no adverse effect on the performance of the capacitor. For liquid-filled capacitors, the same material shall be used for impregnating as is used for filling.

3.3.2 Metals. Metals shall be of a corrosion resisting type, or shall be plated or treated to resist corrosion (see [3.11](#)).

3.4 Interface and physical dimensions. Capacitors shall meet the interface and physical dimensions specified (see [3.1](#)).

3.4.1 Case. Each capacitor shall be enclosed in a hermetically-sealed metal case which will protect the capacitor element from moisture and mechanical damage under all of the specified test conditions.

3.4.2 Capacitor elements. The capacitor elements shall consist of conducting layers separated by two or more layers of dielectric tissues (paper).

3.4.2.1 Noninductive construction. Capacitors having capacitance and dc voltage ratings equal to or less than 1 microfarad and 3,000 volts, respectively, shall have extended foil construction, tab construction, or an equivalent construction. When tab construction is used, each pair of tabs shall be brought out from opposite foils within one turn of the foil winding from each other, except as specified (see [3.1](#) and [6.13](#)).

3.4.3 Terminals.

3.4.3.1 Case as terminal. When the case is a terminal, any protective coating applied to the mounting surface shall be such as to provide a direct conducting path for an electric current from the case to the surface on which it is mounted.

## MIL-C-25F

3.4.3.2 Solder lugs and solder-lug terminals. Solder lugs and solder lug-terminals may be of any shape, providing dimensional limits are met, and shall be coated with solder having a tin content of 40 to 70 percent (see 6.16).

3.4.4 Pure tin. The use of pure tin, as an underplate or final finish, is prohibited both internally and externally. Tin content of capacitor components and solder shall not exceed 97 percent, by mass. Tin shall be alloyed with a minimum of 3 percent lead, by mass (see 6.7).

3.5 Dielectric withstanding voltage. When tested as specified in 4.6.2, capacitors shall withstand the direct current (dc) potential specified without permanent damage or open-circuiting or short-circuiting.

3.6 Insulation resistance.

3.6.1 Terminal to terminal. When capacitors are tested as specified in 4.6.3, the insulation resistance shall not be less than the applicable values specified in table V (see figure 1).

3.6.2 Terminals to case. When capacitors are tested as specified in 4.6.3, the insulation resistance, measured between any terminal and the case, when the case is not a terminal, shall exceed 3,000 megohms.

TABLE V. Terminal-to-terminal insulation resistance measurements.

Capacitance rating	Minimum insulation resistance
<u>Characteristic E</u> 0.33 microfarads, and less Greater than 0.33 microfarads	<u>At +25°C ± 3°C</u> <u>1/</u> 6,000 megohms 2,000 megohm-microfarads <u>2/</u>
0.033 microfarads and less Greater than 0.033 microfarads	<u>At +85°C ± 3°C</u> 600 megohms 20 megohm-microfarads <u>2/</u>
<u>Characteristic F</u> 0.33 microfarads and less Greater than 0.33 microfarads	<u>At +25°C ± 3°C</u> <u>1/</u> 4,500 megohms 1,500 megohm-microfarads <u>2/</u>
0.033 microfarads and less Greater than 0.033 microfarads	<u>At +85°C</u> 450 megohms 15 megohm-microfarads <u>2/</u>
<u>Characteristic K</u> 0.33 microfarads and less Greater than 0.33 microfarads	<u>At +25°C ± 3°C</u> <u>1/</u> 18,000 megohms 6,000 megohm-microfarads <u>2/</u>
0.067 microfarads, and less Greater than 0.067 microfarads	<u>At +125°C ± 3°C</u> 150 megohms 10 megohm-microfarads <u>2/</u>

1/ For corrections, if measurements are made at other temperatures between +20°C and +35°C, see table VI.

2/ Product obtained by multiplying the capacitance in microfarads by the insulating resistance in megohms.

MIL-C-25F

TABLE VI. Insulation-resistance correction factors.

Degrees centigrade	Correction factor	Degrees centigrade	Correction factor
+20	1.42	+28	0.82
+21	1.33	+29	0.76
+22	1.24	+30	0.71
+23	1.16	+31	0.67
+24	1.08	+32	0.63
+25	1.00	+33	0.59
+26	0.94	+34	0.55
+27	0.87	+35	0.51

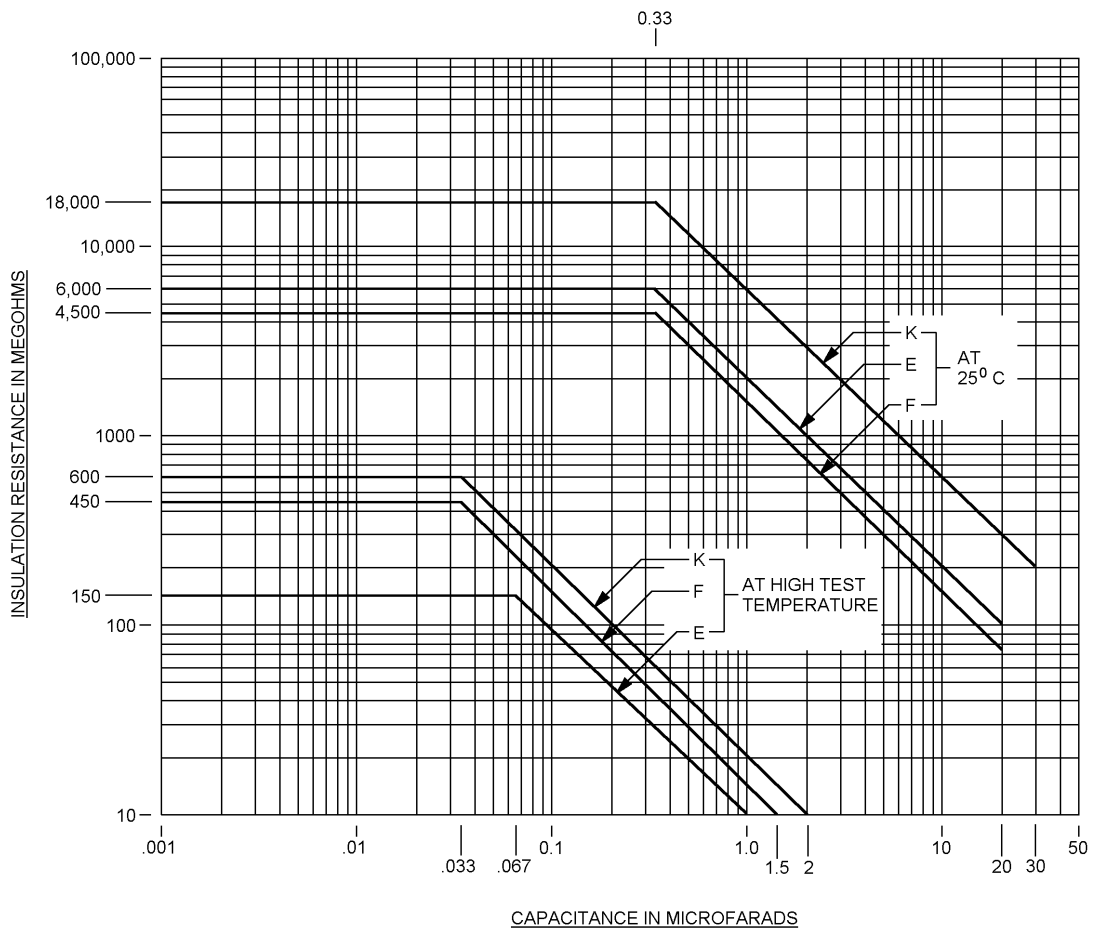

FIGURE 1. Graphical representation of insulation resistance requirements specified in 3.6.1 and table V.

## MIL-C-25F

3.7 Capacitance. When measured as specified in 4.6.4, the capacitance shall be within the tolerance shown in the type designation (see 3.1).

3.8 Dissipation factor. When measured as specified in 4.6.5, the dissipation factor shall be not more than 1.0 percent.

3.9 Barometric pressure (reduced) (Qualification inspection only). Capacitors shall withstand the dc potential specified in 4.6.6 without visible damage, external flashover, open-circuiting or short-circuiting (see 3.1).

3.10 Vibration (low frequency). When capacitors are tested as specified in 4.6.7, there shall be no mechanical damage, and the measurement shall show no evidence of intermittent contacts, open-circuiting or short-circuiting.

3.11 Salt atmosphere (corrosion). As a result of the test specified in 4.6.8, there shall be no harmful or extensive corrosion, and at least 90 percent of any exposed metal surface of the capacitor shall be protected by the finish. For capacitors with painted cases, not more than 10 percent of the surfaces shall be affected by flaking, peeling, or blistering of paint. The marking shall remain legible. In addition, there shall be not more than 10 percent corrosion of the terminal hardware or mounting surface.

3.12 Thermal shock and immersion. When tested as specified in 4.6.9, capacitors shall meet the following requirements:

a. Dielectric withstanding voltage:

(1) Terminal to terminal: As specified in 3.5.

(2) Terminal to case (when case is not a terminal): As specified in 3.5.

b. Insulation resistance:

(1) Terminal to terminal: Not less than 30 percent of the value specified in 3.6.1.

(2) Terminal to case (when case is not a terminal): Not less than 50 percent of the value specified in 3.6.2.

In addition, there shall be no harmful or extensive corrosion of the capacitors. The marking shall remain legible.

3.13 Terminal strength. When capacitors are tested as specified in 4.6.11, there shall be no mechanical damage to the capacitor or terminals; no part of any terminal shall loosen or rupture.

3.14 Moisture resistance. When tested as specified in 4.6.12, capacitors shall meet the following requirements.

a. Dielectric withstanding voltage:

(1) Terminal to terminal: As specified in 3.5.

(2) Terminal to case (when case is not a terminal): As specified in 3.5.

b. Insulation resistance:

(1) Terminal to terminal: Not less than 30 percent of the value specified in 3.6.1.

(2) Terminal to case (when case is not a terminal): Not less than 50 percent of the value specified in 3.6.2.

The marking shall remain legible.

3.15 Seal. When capacitors are tested as specified in 4.6.13, there shall be no evidence of leakage.

## MIL-C-25F

3.16 Low ambient temperature and capacitance change with temperature. When tested as specified in 4.6.14, capacitors shall withstand the application of rated dc voltage (see 3.1) without breakdown or flashover. The capacitance change over the operating temperature range shall not exceed the following limits:

- Characteristic E:  $\pm 10$  percent.
- Characteristic F: + 10 percent, - 30 percent.
- Characteristic K: + 7.5 percent, - 10 percent.

3.17 Life. When tested as specified in 4.6.15, capacitors shall meet the following requirements:

- a. Insulation resistance at +25°C: Not less than 30 percent of the value specified in 3.6.1.
- b. Capacitance: Change not more than 10 percent from initial value obtained when measured as specified in 4.6.4, except for characteristic K, which shall be 5 percent.
- c. Dissipation factor: Shall not exceed 1 percent when measured as specified in 4.6.5, except for characteristic F which shall not exceed 1.5 percent.

In addition, there shall be no mechanical failure, leakage of impregnant or filling compounds, open-circuiting or short-circuiting.

3.18 Flashpoint of impregnant or filling compound. When tested as specified in 4.6.16, the flashpoint of impregnant or filling compound shall be no lower than +135°C for characteristics E and F; and no lower than +145°C for characteristic K.

3.19 Marking.

3.19.1 Capacitor identification marking. Capacitors shall be marked with the type designation and the manufacturer's name or code symbol. There shall be no space between the symbols which comprise the type designation. If lack of space requires it, the type designation may appear on two lines. In this event, the type designation shall be divided between the circuit symbol and the characteristic symbols, and shall appear on two lines as shown in the following example:

CP53B1  
EB105K1

On multiple-section capacitors, the case adjacent to the common terminal, if the terminal is not the case, shall be marked with a "C". If space permits, the capacitance in microfarads and the rating dc voltage shall also be marked. Paper labels shall not be used.

3.20 Workmanship. Capacitors shall be processed in such a manner as to be uniform in quality and shall be free from pits, corrosion, cracks, rough edges, and other defects that will affect life, serviceability, or appearance.

3.20.1 Riveting. The riveting operation shall be performed carefully to insure that the rivet is tight and satisfactorily headed.

#### 4. VERIFICATION.

4.1 Test equipment and inspection facilities. Test equipment and inspection facilities shall be of sufficient accuracy, quality, and quantity to permit performance of the required inspection. The supplier shall establish calibration of inspection equipment to the satisfaction of the Government.

4.2 Classification of inspections. The inspections specified herein are classified as follows:

- a. Qualification inspection (see 4.4).
- b. Conformance inspection (see 4.5).



## MIL-C-25F

4.3 Inspection conditions. Unless otherwise specified herein, all inspections shall be performed in accordance with the test conditions specified in "GENERAL REQUIREMENTS" of [MIL-STD-202](#).

4.4 Qualification inspection. Qualification inspection shall be performed at a laboratory acceptable to the Government (see [6.3](#)).

4.4.1 Sample size. The number of capacitors to be submitted for qualification inspection and the amount of impregnant or filling compound shall be as specified in [appendix A](#) of this specification. The sample shall be taken from a production run and shall be produced with equipment and procedures normally used in production.

4.4.2 Inspection routine.

4.4.2.1 Capacitor submission. Sample capacitors shall be subjected to the examinations and tests specified in [table VII](#), in the order shown. Two specimens of each type represented in a sample shall be subjected to visual and mechanical examination (internal), and the remaining capacitors shall be subjected to the remainder of the group I examination and tests. The capacitors shall then be divided into test groups as specified in [table VII](#) and subjected to the tests for their particular group.

4.4.2.2 Impregnant or filling compound. The sample of impregnant or filling compound (see [A.2.1.3](#)) shall be subjected to the flashpoint of impregnant or filling compound test specified in [table VII](#).

4.4.2.3 Capacitors with alternate terminals, case materials, and applied finish. Sample capacitors (see [A.2.1.4](#) to [A.2.1.6](#)) shall be subjected to the examinations and tests of groups I, II, and III specified in [table VII](#), in the order shown. After completion of the group I tests, the specimens shall be divided into two equal groups and subjected to the test specified in groups II and III. No defectives shall be allowed for group I, and 1 defective shall be allowed for each of groups II and III.

4.4.3 Defectives. Defectives in excess of those allowed in [table VII](#) and [4.4.2.3](#) shall be cause for refusal to grant qualification. If a multiple-section capacitor has a defect in any section, it shall be considered as one defective.

## MIL-C-25F

TABLE VII. Qualification inspection.

Examination or test	Requirement paragraph	Method paragraph	Number of sample units to be inspected	Number of defectives allowed 1/	
Flashpoint of impregnant or filling compound	3.18	4.6.16	See A.2.1.3	0	
<u>Group I</u> Visual and mechanical examination (internal): Material, design, construction, and physical dimensions Marking 2/ Workmanship	3.1, 3.3 to 3.4.4 3.19 3.20 to 3.20.1	4.6.1	2	0	
Visual and mechanical examination (external): Marking 2/ Workmanship	3.19 3.20 to 3.20.1	4.6.1	25 3/	1	
Dielectric withstanding voltage	3.5	4.6.2			
Insulation resistance	3.6	4.6.3			
Capacitance	3.7	4.6.4			
Dissipation factor	3.8	4.6.5			
Barometric pressure	3.9	4.6.6			
<u>Group II</u> Vibration (low frequency)	3.10	4.6.7	6	1	1
Salt atmosphere	3.11	4.6.8			
Thermal shock and immersion	3.12	4.6.9			
<u>Group III</u> Terminal strength	3.13	4.6.11	6	1	1
Moisture resistance	3.14	4.6.12			
<u>Group IV</u> Seal	3.15	4.6.13			1
Low ambient temperature and capacitance change with temperature	3.16	4.6.14	12		
Life	3.17	4.6.15			

1/ A specimen having one or more defects shall be considered as one defective.

2/ Marking defects are based on visual examination only and shall be charged only for illegible, incomplete, or incorrect marking. Any subsequent electrical defects shall not be used as a basis for determining marking defects.

3/ One additional specimen is included in each sample of 27 specimens to permit substitution for the allowable defective in group I.

#### 4.5 Conformance inspection.

4.5.1 Inspection of product for delivery. Inspection of product for delivery shall consist of group A inspection.

4.5.1.1 Inspection lot. An inspection lot, as far as practicable, shall consist of capacitors grouped by style and characteristics, as specified (see 3.1). Capacitors of different characteristics having the same impregnant shall be considered as capacitors of the same characteristic.

4.5.2 Group A inspection. Group A inspection shall consist of the examinations and tests specified in table VIII, in the order shown.

4.5.2.1 Sampling plan. The sampling plan shall be performed on an inspection lot basis as specified in table VIII.

## MIL-C-25F

4.5.2.2 Rejected lots. If an inspection lot is rejected for subgroup 2, the supplier may withdraw the lot, rework it to correct the defects, or screen out the defective units, as applicable and reinspect. If one or more defects are found during this reinspection, the lot shall be rejected and shall not be supplied to this specification. Reinspected lots shall be separated from new lots and shall be clearly identified as reinspected lots.

TABLE VIII. Group A inspection.

Inspection	Requirement paragraph	Test method paragraph	Sampling procedure
<u>Subgroup 1</u>			
Thermal shock	3.12	4.6.9.1	100 percent
Seal	3.15	4.6.13	
Dielectric withstanding voltage	3.5	4.6.2	
Insulation resistance (at +25°C)	3.6	4.6.3	
Capacitance	3.7	4.6.4	
Dissipation factor	3.8	4.6.5	
<u>Subgroup 2</u>			
Visual mechanical examination:			13 samples 0 failures
Materials	3.3 to 3.3.2	4.6.1	
Body dimensions	3.1		
Design and construction (other than body dimensions)	3.4 to 3.4.4		
Marking <sup>1/</sup>	3.19 to 3.19.1		
Workmanship	3.20 to 3.20.1		

<sup>1/</sup> Marking defects are based on visual examination and shall be charged only for illegible, incomplete, or incorrect marking. Any subsequent electrical defects shall not be used as the basis for determining marking defects.

4.5.3 Group B inspection. Group B inspection is not required.

4.5.4 Periodic group C inspection. Periodic group C inspection shall consist of the tests specified in [table IX](#) in the order shown, and shall be performed on sample units selected from lots that have passed group A inspection. Except where the results of this inspection show noncompliance with the applicable requirements (see 4.5.4.2), delivery of products which have passed group A shall not be delayed pending the results of this periodic inspection.

4.5.4.1 Sampling plan. For subgroup 1 and subgroup 2, sample units shall be taken from production every six months. The time period for vibration shall be a minimum of every 24 months. For subgroup 3 and subgroup 4, sample units shall be taken from production every year. A different set of sample units shall be selected for each subgroup. Sample units of the same style (any one style covered by a specification sheet may be representative of any other style specified therein; see [table A-1](#)) shall be selected in each characteristic, irrespective of voltage and capacitance. These sample units may be in any capacitance tolerance. If the number of defectives exceeds those allowed in [table IX](#), the sample shall be considered to have failed.

4.5.4.2 Noncompliance. If a sample fails to pass group C inspection, the supplier shall take corrective action on the materials or processes or both, as warranted, and on all units of product which can be corrected and which were manufactured under essentially the same conditions, with essentially the same materials and processes, and which are considered subject to the same failure. Acceptance of the product shall be discontinued until corrective action acceptable to the Government has been taken. After the corrective action has been taken, additional sample units shall be subjected to group C inspection (all inspections, or the inspections which the sample failed, at the option of the Government). Group A inspection may be reinstated; however, final acceptance shall be withheld until the group C inspection has shown that the corrective action was successful. In the event of failure after reinspection, information concerning the failure and the corrective action taken shall be furnished to the contracting officer.

4.5.4.3 Disposition of sample units. Sample units that have been subjected to group C inspection shall not be delivered on the contract or order.

## MIL-C-25F

TABLE IX. Group C inspection

Inspection	Requirement paragraph	Method paragraph	Number of samples	Number of defectives allowed
<u>Subgroup 1</u> Vibration (low frequency) <u>1/</u> Immersion <u>2/</u>	3.10 3.12	4.6.7 4.6.9.2	5	0
<u>Subgroup 2</u> Insulation resistance (at high ambient test temperature) Life	3.6 3.17	4.6.3 4.6.15	5	0
<u>Subgroup 3</u> Terminal strength <u>2/</u> Moisture resistance <u>2/</u>	3.13 3.14	4.6.11 4.6.12	6	1
<u>Subgroup 4</u> Low ambient temperature and capacitance change Salt atmosphere (corrosion) <u>2/</u>	3.16 3.11	4.6.14 4.6.8	6	1

1/ The time period for vibration is a minimum of once every 24 months.

2/ If the manufacturer can demonstrate that this test has been performed five consecutive times with zero failures, this test, with the approval of the qualifying activity, can be deleted. The manufacturer, however, shall perform this test every three years after the deletion as part of long term design verification. If the design, material, construction, or processing of the part is changed, or if there are any quality problems, the qualifying activity may require resumption of the specified testing. Deletion of testing does not relieve the manufacturer from meeting the test requirements in case of dispute.

4.5.5 Verification of qualification. Every 12 months, the manufacturer shall provide verification of qualification to the qualifying activity. Continuation of qualification shall be based on meeting the following requirements:

- a. Group A inspection.
- b. Periodic group C inspection.

In the event that there is no production of a single style device during a reporting period and the manufacturer is listed for more than one style on the QPL, a report shall be submitted certifying that the manufacturer still has the capabilities and facilities necessary to produce that product. If during three consecutive reporting periods there has been no production of a given style, the manufacturer may be required, at the discretion of the qualifying activity, to submit a representative product of that style to testing.

#### 4.6 Methods of examination and test.

4.6.1 Visual and mechanical examination. Capacitors shall be examined to verify that the materials, design, construction, physical dimensions, marking, and workmanship are in accordance with the applicable requirements (see 3.1, 3.3 to 3.4.4, and 3.19 to 3.20.1).

4.6.2 Dielectric withstanding voltage (see 3.5). Unless otherwise specified (see 3.1), capacitors shall be tested in accordance with method 301 of MIL-STD-202, and as detailed in table X. The surge current shall be limited to between 5 milliamperes and 1 ampere. When necessary, a suitable current-limiting resistor shall be inserted into the circuit. At least 95 percent of the specified potential shall appear across the terminals of the capacitor prior to and during the period of time specified (see 3.5 and table X).

## MIL-C-25F

TABLE X. Dielectric withstanding voltage test.

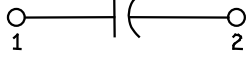
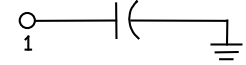
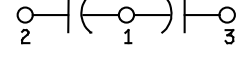
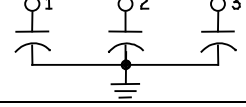
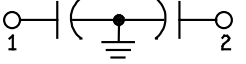
Circuit diagram	Test	Test connections	Test voltage (percent of rated dc voltage)	Time test voltage applied (minute)
SYMBOL 1 	Terminal to terminal	1 to 2	200 <u>1/</u>	1 <u>2/</u>
	Terminal to case	1 and 2 to case	400 <u>5/</u>	1 <u>3/</u> <u>4/</u>
200 + 1,000 volts <u>6/</u>			1 <u>3/</u> <u>4/</u>	
SYMBOL 2 	Terminal to terminal	1 to case	200 <u>1/</u>	1 <u>2/</u>
SYMBOL 4 	Terminal to terminal	1 to 2 and 3 together	200 <u>1/</u>	1 <u>7/</u>
		2 to 3	200	1 <u>7/</u>
	Terminal to case	1, 2 and 3 to case	400	1 <u>3/</u> <u>4/</u>
			200 + 1,000 volts	1 <u>3/</u> <u>4/</u>
SYMBOL 5 	Terminal to terminal	1, 2, and 3 to case	200	1 <u>7/</u>
		1 and 2 to 3	200	1 <u>7/</u>
		1 to 2	200	1 <u>7/</u>
SYMBOL 6 	Terminal to terminal	1 and 2 to case	200	1 <u>7/</u>
		1 to 2		

1/ 175 percent of rated dc voltage after thermal shock and immersion, and moisture resistance tests.

2/ For conformance inspection and at the option of the supplier, either 200 percent of rated dc voltage shall be applied for 15 seconds or 250 percent of rated dc voltage for not less than 1 second.

3/ For conformance inspection, test voltage shall be applied for 1 second.

4/ For conformance inspection, applications may be made between each terminal individually and the case, at the option of the supplier.

5/ For capacitors having dc voltage ratings of 600 volts and less.

6/ For capacitors having dc voltage ratings greater than 600 volts.

7/ For conformance inspection, the application may be made for 1 second if the capacitor has passed group A inspection.

## MIL-C-25F

4.6.3 Insulation resistance (see 3.6). Capacitors shall be tested in accordance with [method 302 of MIL-STD-202](#). The following details shall apply:

- a. Test potential: A potential equal to the +40°C rated dc voltage or 500 volts dc, whichever is less, shall be applied.
- b. Points of measurement:
  - (1) Terminal to terminal: Insulation resistance shall be measured between terminals at the applicable high-test temperature specified in [table II](#) and at +25°C, or corrected thereto. For conformance inspection, the measurement at the high-test temperature is required only for specimens which shall be subjected to the life test.
  - (2) Terminal to case: When the case is not a terminal, the measurement of the insulation resistance shall be made between each terminal and the case at +25°C, or corrected thereto.

4.6.4 Capacitance (see 3.7). Capacitors shall be tested in accordance with [method 305 of MIL-STD-202](#). The following details shall apply:

- a. Test frequency: 1,000 ± 100 Hz for capacitors when nominal capacitance does not exceed 1 microfarad and whose rated dc voltage does not exceed 3,000 volts. For capacitors not within these limits, measurements shall be made at a frequency of 100 ± 10 Hz.
- b. Limit of accuracy: Shall be within ± 2 percent.

4.6.5 Dissipation factor (see 3.8). The dissipation factor of each capacitor shall be measured at a voltage not greater than 20 percent of the rated dc voltage. If the nominal capacitance does not exceed 1 microfarad, and if the rated dc voltage does not exceed 3,000 volts, measurement shall be made at a frequency of 1,000 ± 100 Hz. Measurements on capacitors not within these limits shall be made at a frequency of 100 ± 10 Hz.

4.6.6 Barometric pressure (reduced) (qualification inspection only) (see 3.9). Capacitors shall be tested in accordance with [method 105 of MIL-STD-202](#). The following details and exceptions shall apply:

- a. Method of mounting: Capacitors shall be securely fastened by normal mounting means.
- b. Test condition: Unless otherwise specified (see 3.1), B.
- c. Tests during subjection to reduced pressure: Unless otherwise specified (see 3.1), a potential equal to 125 percent of rated dc voltage shall be applied for at least 1 minute between each terminal and every other terminal in turn, and between the case and each terminal not connected to the case. A suitable means shall be used to detect momentary or permanent breakdown.

4.6.7 Vibration (Low frequency) (see 3.10). Capacitors shall be tested in accordance with [method 201 of MIL-STD-202](#). The following details and exceptions shall apply:

- a. Tests and measurements prior to vibration: Not applicable.
- b. Method of mounting: Securely fastened by normal mounting means.
- c. Duration of vibration: 3 hours (60 minutes in each direction).
- d. Tests and measurements during vibration: during the last 30 minutes of vibration in each direction, an electrical measurement (see 6.14) shall be made to determine intermittent contacts or open-circuiting or short-circuiting.
- e. Examination after vibration: Capacitors shall be visually examined for evidence of mechanical damage.

## MIL-C-25F

4.6.8 Salt atmosphere (corrosion) (see [3.11](#)). Capacitors shall be tested in accordance with [method 101 of MIL-STD-202](#), test condition B. After this test, capacitors shall be examined for evidence of corrosion and obliteration of marking. Capacitors with painted cases shall be examined for flaking, peeling, or blistering of paint.

4.6.9 Thermal shock and immersion (see [3.12](#)).

4.6.9.1 Thermal shock. Capacitors shall be tested in accordance with [method 107 of MIL-STD-202](#). The following details and exceptions shall apply:

- a. Conditioning prior to first cycle: 15 minutes at room ambient.
- b. Test condition: A, except that in step 3, sample capacitors shall be conditioned at high ambient test temperature (see [3.1](#)).
- c. Measurement after cycling: Not applicable.

4.6.9.2 Immersion. Following thermal shock, capacitors shall be tested in accordance with [method 104 of MIL-STD-202](#). The following details and exceptions shall apply:

- a. Test condition: C, except that the duration of each immersion shall be 30 minutes. Change from one solution to the other shall be made in not more than 3 seconds.
- b. Measurements after final cycle: Dielectric withstanding voltage and insulation resistance at +25°C shall be measured as specified in [4.6.2](#) and [4.6.3](#).
- c. Visual examination: After this test, capacitors shall be visually examined for corrosion and obliteration of marking.

4.6.11 Terminal strength (see [3.13](#)). Capacitors shall be tested in accordance with [method 211 of MIL-STD-202](#). The following details and conditions shall apply:

- a. Test condition A (pull test): applied force: 5 pounds.
- b. Test condition E (torque test): applied force: 2 pound-inch.

4.6.12 Moisture resistance (see [3.14](#)). Capacitors shall be tested in accordance with [method 106 of MIL-STD-202](#). The following details and exceptions shall apply:

- a. Mounting: Capacitors shall be mounted by normal mounting means, except during measurement.
- b. Initial measurements: Not applicable.
- c. Polarization voltage: 100 volts shall be applied across the terminals of 50 percent of the capacitors. No potential shall be applied to the remaining 50 percent of the capacitors.
- d. Loading voltage: Not applicable.
- e. During step 7, capacitors shall be removed from the humidity chamber at the same time each day.
- f. Final measurements: Dielectric withstanding voltage and insulation resistance at +25°C shall be measured as specified in [4.6.2](#) and [4.6.3](#).
- g. Visual examination: After this test, capacitors shall be visually examined for corrosion and obliteration of marking.

## MIL-C-25F

4.6.13 Seal (see 3.15 and 6.10).

4.6.13.1 Liquid-impregnated capacitors and solid-impregnated capacitors. Liquid-impregnated and solid-impregnated capacitors shall be tested in accordance with [method 112 of MIL-STD-202](#), test condition A, except that bath temperature shall be as follows:

For characteristics E and F: +85°C +3°C, -0°C.

For characteristic K: +125°C +3°C, -0°C.

4.6.13.2 Liquid-filled capacitors. Liquid-filled capacitors shall be tested in accordance with [method 112 of MIL-STD-202](#), test condition A, for 10 minutes on each of two opposite sides at test temperature as follows:

For characteristic E and F: +85°C +3°C, -0°C.

For characteristic K: +125°C +3°C, -0°C.

4.6.14 Low ambient temperature and capacitance change with temperature (see 3.16).

4.6.14.1 Low ambient temperature. Capacitors shall be placed in a chamber maintained at  $-55^{\circ}\text{C} \pm 3^{\circ}\text{C}$ , and a rated dc voltage shall be applied at this condition for  $48 \pm 4$  hours. The air within the conditioning chamber shall be circulated.

4.6.14.2 Capacitance change with temperature. At the conclusion of the test specified in [4.6.14.1](#), capacitance measurements shall be made as specified in [4.6.4](#), except that the measurement shall be made at  $-55^{\circ}\text{C} \pm 3^{\circ}\text{C}$ ,  $+25^{\circ}\text{C} \pm 5^{\circ}\text{C}$ , the applicable high-test temperature, and  $+25^{\circ}\text{C} \pm 5^{\circ}\text{C}$ . The  $-55^{\circ}\text{C}$  measurement shall be made before the capacitors are removed from the conditioning chamber. The measurement at each temperature shall be recorded when two successive readings taken at 5 minute intervals indicate no change in capacitance. Initial  $+25^{\circ}\text{C}$  measurement shall be used as the reference measurement to determine the percent of capacitance change at the low and high-test temperatures. Capacitors shall then be visually examined for evidence of breakdown, arcing, and other visible mechanical damage.

4.6.15 Life (see 3.17). Capacitors shall be tested in accordance with [method 108 of MIL-STD-202](#), test condition B (250 hours +8 hours, -0 hours). The following details shall apply:

- a. Electrical load: 120 percent of rated dc voltage.
- b. Final measurements (at  $+25^{\circ}\text{C}$ ):
  - (1) Insulation resistance:
    - (a) Terminal to terminal: Not less than 30 percent of the value specified in [table IV](#).
  - (2) Capacitance:
    - (a) Characteristic E and F: Within 10 percent of initial value.
    - (b) Characteristic K: Within 5 percent of initial value.
  - (3) Dissipation factor:
    - (a) Characteristics E and K: Change not more than 1 percent from initial value.
    - (b) Characteristic F: Change not more than 1.5 percent from initial value.



## MIL-C-25F

4.6.16 Flashpoint of impregnant or filling compound (see 3.18). The flash-point of impregnant or filling compound shall be measured as specified in [ASTM Publication D92](#), except that fire point and precision do not apply. The word "impregnant" shall be substituted for the word "oil" throughout the test method.

## 5. PACKAGING

5.1 Packaging. For acquisition purposes, the packaging requirements shall be as specified in the contract or order (see 6.2). When packaging of materiel is to be performed by DoD or in-house contractor personnel, these personnel need to contact the responsible packaging activity to ascertain packaging requirements. Packaging requirements are maintained by the Inventory Control Point's packaging activities within the Military Service or Defense Agency, or within the military service's system commands. Packaging data retrieval is available from the managing Military Department's or Defense Agency's automated packaging files, CD-ROM products, or by contacting the responsible packaging activity.

## 6. NOTES

(This section contains information of a general or explanatory nature that may be helpful, but is not mandatory.)

6.1 Intended use. These paper or plastic capacitors, because of their low-power factor, high-breakdown voltage, low-dielectric absorption, and high-insulation resistance, are intended for use in filter, bypass, and blocking applications where the ac component of the impressed voltage is small with respect to the dc voltage rating. Capacitors covered by this specification are unique due to the fact that these devices must be able to operate satisfactorily under the following demanding conditions: low frequency vibration and wide temperature fluctuations. These capacitors also receive 250 hours of life testing. Commercial components are not designed to withstand these military environmental conditions.

6.2 Ordering data. Procurement documents should specify the following:

- a. Title, number, and date of this specification.
- b. Title, number, and date of the applicable specification sheet, and the complete PIN (see 1.2.1 and 3.1).
- c. Packaging requirements (see 5.1).

6.3 Qualification. With respect to products requiring qualification, awards will be made only for products which are, at the time of award of contract, qualified for inclusion in Qualified Products List whether or not such products have actually been so listed by that date. The attention of the contractors is called to these requirements, and manufacturers are urged to arrange to have the products that they propose to offer to the Federal Government tested for qualification in order that they may be eligible to be awarded contracts or orders for the products covered by this specification. Information pertaining to qualification of products may be obtained from the Defense Supply Center, Columbus, ATTN: DLA Land and Maritime-VQP, PO Box 3990, Columbus, OH 43218-3990, or by e-mail to [vqp.mp@dla.mil](mailto:vqp.mp@dla.mil). An online listing of products qualified to this specification may be found in the Qualified Products Database (QPD) at <https://assist.daps.dla.mil>.

6.4 PIN. This specification requires a PIN that describes codification or classification and appropriate references to associated documents (see 1.2.1 and 3.1).

6.5 Environmentally preferable material. Environmentally preferable materials should be used to the maximum extent possible to meet the requirements of this specification. As of the dating of this document, the U.S. Environmental Protection Agency (EPA) is focusing efforts on reducing 31 priority chemicals. The list of chemicals and additional information is available on their website at <http://www.epa.gov/osw/hazard/wastemin/priority.htm>. Included in the list of 31 priority chemicals are cadmium, lead, and mercury. Use of the materials on the list should be minimized or eliminated unless needed to meet the requirements specified herein (see section 3).

6.6 Subject term (key word) listing.

Capacitance  
Vibration

## MIL-C-25F

6.7 Tin whisker growth. The use of alloys with tin content greater than 97 percent, by mass, may exhibit tin whisker growth problems after manufacture. Tin whiskers may occur anytime from a day to years after manufacture and can develop under typical operating conditions, on products that use such materials. Conformal coatings applied over top of a whisker-prone surface will not prevent the formation of tin whiskers. Alloys of 3 percent lead, by mass, have shown to inhibit the growth of tin whiskers. For additional information on this matter, refer to ASTM-B545 (Standard Specification for Electrodeposited Coatings of Tin).

6.8 Voltage derating with temperature. The applicable dc voltage-derating factor depends upon the characteristic and the energy content of the capacitor fully charged. Voltage-derating factors for various temperatures are determined from the curves shown. The permissible operating voltages, while based on incomplete data, are the capacitor supplier's best estimate to provide a life expectancy of 8,800 hours of continuous operation at high ambient temperatures. Longer life can be expected of all types by operation at still lower voltages; for example, a life expectancy of approximately 44,000 hours may be obtained by operation at 70 percent of the voltage specified in 1.2.1.5. Also, a life longer than 8,800 hours may be expected at the voltage specified in 1.2.1.5, if the high ambient temperature prevails for only a portion of the total operating time (see 1.2.1.5 and 3.1).

6.8.1 DC capacitors. The energy content of a dc capacitor when fully charge is determined by use of the following formula:

$$W = \frac{CV^2}{2}$$

Where: W = energy content in watt-seconds.  
C = nominal capacitance in farads.  
V = rated dc voltage in volts at +40°C.

When the characteristic and watt-second group have been determined (see below), the voltage-derating factors for the applicable temperatures are as specified (see 1.2.1.5 and 3.1).

Watt-second grouping:

Group I:

Group IA: 0 to 0.08 watt-second.  
Group IB: 0.08 to 0.5 watt-second.

Group II: 0.5 watt-second to 5 watt-seconds.

Group III: 5 to 50 watt-seconds.

Group IV: 50 watt-seconds and greater.

6.9 DC voltage. A dc voltage is a unidirectional voltage in which the changes in value are either zero or so small that they may be neglected (see 1.2.1.5).

6.10 Black (ultra-violet) light. Black (ultra-violet) light is not to be used during the seal test (see 4.6.13).

6.11 Liquid-filled capacitor. A liquid filled capacitor is a capacitor in which a liquid impregnant occupies substantially all of the case volume not required by the capacitor element and its connections. Space may be allowed for the expansion of the liquid under temperature variations (see 3.3.1).

6.12 Liquid-impregnant capacitor. A liquid impregnant capacitor is a capacitor in which the impregnant is dominantly contained within the foil-and-paper winding, but does not occupy substantially all of the case volume not required by the capacitor element and its connections (see 3.3.1).

6.13 Noninductive construction. Noninductive construction means a construction which reduces, but usually does not eliminate completely, the effective inductance of the capacitor. This result is obtained by so routing the currents in the electrodes that the magnetic fields tend to cancel each other, or by making the current paths very short (see 3.4.2.1).

MIL-C-25F

6.14 Magnetic-case capacitor. A magnetic-case capacitor is a capacitor in which some part of the case is made of magnetizable material.

6.15 Non-magnetizable-case capacitor. A non-magnetizable-case capacitor is a capacitor in which no part of the case is made of magnetizable material; however, the end-seal may be made of a material having a ferrous-metal content in order to effect a glass-to-metal seal.

6.16 Solder coating. Coating of solder lugs should be such that lugs can withstand extended storage without deterioration of soldering qualities.

6.17 Vibration (final measurement). During the last 30 minutes of vibration in each direction, an electrical signal of  $1 \pm 0.2$  kHz at a level of  $1 \pm 0.2$  volts is placed across the capacitor and measured with a suitable alternating-current recording device for the purpose of determining the presence of open circuits, short circuits, or intermittent contacts.

6.18 Standard capacitor types. Equipment designers should refer to [MIL-HDBK-198](#) "Capacitors, Selection and Use of" for standard capacitor types and selected values chosen from this specification. [MIL-HDBK-198](#) provides a selection of standard capacitors for new equipment design.

6.19 Changes from previous issue. The margins of this specification are marked with vertical lines to indicate where changes from the previous issue were made. This was done as a convenience only and the Government assumes no liability whatsoever for any inaccuracies in these notations. Bidders and contractors are cautioned to evaluate the requirements of this document based on the entire content irrespective of the marginal notations and relationship to the last previous issue.

## MIL-C-25F

## APPENDIX A

## PROCEDURE FOR QUALIFICATION INSPECTION

## A.1. SCOPE

A.1.1 This appendix details the procedure for submission of samples for qualification inspection of capacitors covered by this specification. The procedure for extending qualification of the required sample to other capacitors covered by this specification is also outlined herein. This appendix is a mandatory part of the specification. The information contained herein is intended for compliance.

## A.2. SUBMISSION

A.2.1 Sample.

A.2.1.1 Single-type-capacitor submission. A sample consisting of 27 specimens of each type for which qualification is sought shall be submitted (see A.3.1).

A.2.1.2 Combined capacitor submission (see A.3.2). A maximum of two types of capacitors, 14 specimens of each type within a style group, may be represented in a combined submission. Styles are grouped as specified in table A-I. Both types shall have the same impregnant or filling compound. In view of the relatively few specimens of each type or design represented, a combined submission will be treated similarly to a single-type submission, and the failure of one type or design will disqualify the entire submission. However, when two or more combined submissions of the same capacitor type have been made, and these combined submissions were disqualified in each instance because of failures of the same capacitor type, the results of the tests on the other types may be combined and treated as a single-type submission, provided that:

- a. The combined-test results show compliance with specification requirements and the correct number of specimens were tested.
- b. The capacitors are of the identical types or of the same type except for characteristic (the same impregnant or filling compound shall be used for both characteristics), and that no design changes were made in the interval between the two submissions.
- c. Qualification is considered only for the less stringent characteristic when capacitors were tested in accordance with the requirements for two different characteristics.
- d. The combined results are from tests conducted within 6 months of each other.

TABLE A-I. Style groups.

Style group <u>1/</u>	Styles
D	CP53, CP54, CP55

A.2.1.2.1 Watt-second groups. Two adjacent watt-second groups may be represented. The maximum watt-second rating in the highest voltage shall be submitted in each watt-second group for which qualification is sought. For determination of the watt-second group into which any capacitor falls, the watt-second rating shall be computed on the basis of nominal capacitance and voltage values.

A.2.1.2.2 Design and construction. Two designs or constructions may be represented.

## MIL-C-25F

## APPENDIX A

A.2.1.2.3 Combined characteristics. When qualification is sought for the same impregnant or filling compound used for two characteristics, both characteristics may be represented in a submission; however, the characteristic to be tested shall be as specified in table A-II.

TABLE A-II. Combined characteristics.

Characteristics represented	Characteristics to be tested
K and E	K
E and F	E

A.2.1.3 Impregnant or filling compound. A minimum of 200 cubic centimeters of each impregnant or filling compound used in the capacitors, or a certification of the flashpoint of impregnant or filling compound measured in accordance with 4.6.16 shall be submitted (see A.3.3).

A.2.1.4 Alternate case material. When qualification for specific types of capacitors has been granted and qualification is sought for an alternate case material, 14 capacitors of the same type within the combined-style group utilizing the alternate case material may be submitted (see A.3.5). For the purpose of establishing qualification of alternate case material, all style groups may be considered jointly.

Where qualification has been established for capacitors enclosed in nonferrous case material, qualification may be granted for ferrous case material, providing certification is furnished for the following:

- a. The material and applied finish of the ferrous cases shall be the same as those previously approved for some other capacitor style.
- b. The design and construction of the ferrous cases shall be the same as that of the approved nonferrous case of the same capacitor styles.
- c. No change shall be made in the basic design of the capacitors other than the case material.

A.2.1.5 Alternate applied finish. When qualification for specific types of capacitors has been granted in accordance with A.3.1 and qualification is sought for an alternate applied finish, 14 capacitors of the same type utilizing the alternate finish may be submitted (see A.3.6).

A.2.1.6 Combined alternate case material and applied finish. When qualification is sought for an alternate case material utilizing an applied finish for which qualification has been granted, and, concurrent with this, when qualification is sought for an alternate finish applied to a case material for which qualification has been granted, 7 capacitors of each construction but the same capacitor style may be submitted (see A.3.7).

## A.3. EXTENT OF QUALIFICATION.

A.3.1 Single-type-capacitor submission. Each single-type-capacitor submission shall confer eligibility for qualification for the combination of style, terminal, circuit, and characteristic represented, except as specified below. The voltage-rating qualification shall be restricted to those ratings equal to and less than the rating represented in the submission in the watt-second group represented. The watt-second-rating range of qualification shall be in accordance with table A-III, except that when specified (see 3.1), watt-second group I is limited to capacitors having dc voltage ratings of 1,000 volts or less, and watt-second group II includes capacitors having a watt-second rating of 0 to 0.5 which are not included in watt-second group I.

- a. A circuit may also represent other circuits, as listed below:

## MIL-C-25F

## APPENDIX A

Circuit tested	Circuits also represented
1	2
4	1, 2, 6
5	1, 2, 4, 6
6	1, 2

- b. Any capacitance tolerance may also represent all other available capacitance tolerances.
- c. Any one of styles CP53, CP54, or CP55 may also represent the other two of these styles.
- d. The specimens to which qualification is extended shall be of the same basic design and shall utilize the same materials, finish, impregnant or filling compound as the qualified specimens.
- e. Watt-second group IB may represent watt-second group IA. The watt-second-range of qualification shall be in accordance with table A-III.
- f. For style group D (see [table A-I](#)), capacitor type CP55B5-G254-1 may represent all types; however, submission in accordance with the other provisions of this procedure is preferred.

TABLE A-III. Watt-second range of qualification.

Watt-second group of the submission	Range of qualification
I 0 to 0.5 watt-seconds	All watt-second ratings up to 120 percent of that of the submission.
II 0.5 to 5 watt-seconds	All watt-second ratings up to 120 percent of that of that of the submission but $\geq 0.40$ watt-second.
III 5 to 50 watt-seconds	All watt-second ratings up to 120 percent of that of the submission but $\geq 4.0$ watt-seconds.
IV 50 watt-seconds and greater	All watt-second ratings up to 120 percent of that of the submission but $\geq 40$ watt-seconds.

## MIL-C-25F

## APPENDIX A

A.3.2 Combined capacitor submission. Each combined capacitor submission shall confer eligibility for qualification of the combinations of style, terminal, circuit, and characteristics represented. The voltage-rating qualification shall be restricted to those ratings equal to and less than those represented in each watt-second group of the submission. The watt-second-rating range of qualification for each watt-second group represented in the combined submission shall be in accordance with [table A-III](#), except that when specified (see [3.1](#)), watt-second group I is limited to capacitors having dc voltage rating of 1,000 volts or less, and watt-second group II includes capacitors having a watt-second rating of 0 to 0.5 which are not included in watt-second group I. The provisions applying in the single-type submission (see [A.3.1](#)), shall also apply to the combined-type submission.

A.3.3 Impregnant or filling compound. The qualification of a flashpoint of the impregnant or filling compound with any submission may be extended to permit the use of the same impregnant or filling compound with any other submission.

A.3.4 Alternate terminals. Each submission of capacitors employing an alternate terminal shall confer eligibility for qualification of the terminal submitted in accordance with the existing qualification of the style tested.

A.3.5 Alternate case material. Submission of any qualified type of styles CP53, CP54, or CP55 utilizing an alternate case material shall confer eligibility for qualification of the case material used on that style and other styles limited to the specific types for which the supplier already has qualification.

A.3.6 Alternate applied finish. Submission of any qualified type of uninsulated tubular capacitor utilizing an alternate applied finish (see [A.2.1.5](#)) shall confer eligibility for qualification of that style and any other tubular styles, both insulated and uninsulated, limited to specific types for which the supplier already has qualification. Submission of any other qualified capacitors of cylindrical, bathtub, or rectangular style utilizing an alternate applied finish shall confer eligibility for qualification of all other capacitors of these styles limited to the specific types for which the supplier already has qualification.

A.3.7 Combined alternate case material and applied finish. A combined submission of any qualified style of capacitor utilizing an alternate applied finish on a qualified case material, as well as an alternate case material with a qualified finish (see [A.2.1.6](#)), shall confer eligibility for qualification of the materials and finishes in the same manner as if capacitors utilizing one or the other of the alternate constructions had been submitted separately.

A.3.8 Combined submissions. Example of combined capacitor submission are specified in [table A-IV](#).

TABLE A-IV. Examples of combined capacitor submissions. <sup>1/</sup>

Styles	Types to be submitted	Number of capacitors to be submitted	Watt-second group	Watt-second rating	DC voltage rating
CP53, CP54, CP55	CP55B4EG504-1	14	I	0.5	1,000
	CP55B5EG504-1	14	I	0.38	1,000

<sup>1/</sup> This table is set up as a guide. For other combinations or characteristics, or both, reference is made to the specification sheet.

MIL-C-25F

Custodians:

Army - CR  
Navy - EC  
Air Force - 85  
DLA - CC

Preparing activity:

DLA - CC

(Project 5910-2010-031)

Review activities:

Army - AR, MI  
Navy - AS, MC, OS  
Air Force - 19, 99

NOTE: The activities listed above were interested in this document as of the date of this document. Since organizations and responsibilities can change, you should verify the currency of the information above using ASSIST Online database at <https://assist.daps.dla.mil>.