

MIL-C-25731A (USAF)
AMENDMENT 1
24 MAY 1974

MILITARY SPECIFICATION

CRATES, WOOD, FOR DOMESTIC AND OVERSEAS SHIPMENT OF AIRFRAME
COMPONENTS (2,000 POUND MAXIMUM NET LOAD)

This amendment forms a part of Military Specification MIL-C-25731A (USAF) dated 26 February 1968 and is approved for use by all Departments and Agencies of the Department of Defense.

Page 1

1.1, last line: After "shipment" add "(see 6.1)."

1.2, bottom of page: Delete "(copies of specification, standards and publications --- directed by the contracting officer)."

Page 2

1.2, opposite "Type VII:" Second line insert "6" between "length," and "feet."

2.1, delete and substitute: "2.1 The following documents of the issue in effect on date of invitation for bids or request for proposal, form a part of this specification to the extent specified herein:"

Page 3

2.1, under "FF-B-561" add: "FF-B-575 Bolt, Hexagon and Square."

2.1, delete "FF-B-571 Bolts, Nuts, Studs, and Tap Rivets (and materials for same)" and substitute: "FF-B-584 Bolts, Finned Neck; Keyhead; Machine, Ribbed Neck, Square Neck, Tee Head."

2.1, under "STANDARDS" add: "Federal;" under "Federal" add: Fed. Std. No. 101 - Preservation, Packaging and Packing Materials: Test Procedure."

2.1, under "MIL-HDBK-7" add new paragraph: "(Copies of military specifications and standards required by the contractors in connection with specific procurement functions should be obtained from the procuring activity or as directed by the contracting officer.)"

3.1, delete and substitute: "3.1 First Article Inspection. This specification provides for first article testing (see 4.4). (First Article Inspection Item(s) shall, upon acceptance, be used by inspector as a guide in inspecting future items."

FSC 8115

MIL-C-25731A (USAF)
AMENDMENT 1

Page 4

3.1.7, delete and substitute: "3.1.7 Bolts. Carriage bolts shall conform to the requirements of FF-B-584 and machine bolts shall conform to the requirements of FF-B-575.

Page 7

Table II, delete and substitute revised Table II:

TABLE II

LOAD-BEARING FLOORBOARDS
ALLOWABLE LOAD, IN POUNDS PER INCH OF FLOORBOARD WIDTH
GROUPS I AND II WOOD 1/

Length Between Outside Skids	Thickness of Floorboards (Inches)			
	3/4	1-1/2	2-1/2	3-1/2
<u>Inches</u>	<u>Pounds</u>	<u>Pounds</u>	<u>Pounds</u>	<u>Pounds</u>
12	48	188	520	1,020
18	32	125	347	680
24	24	94	260	510
30	19	75	208	408
36	16	63	173	340
42	14	54	149	291
48	12	47	130	255
60	9	38	104	204
72	8	31	87	120
84	7	27	74	146
96	6	23	65	128
108	5	21	58	113
120	5	19	52	102

1/ If Group III or IV woods are used, the above allowable loads may be increased by 20 percent.

Page 8

3.4.1.2, delete and substitute: "3.4.1.2 Rubbing Strips. Rubbing strips shall be used on each skid for gross loads over 150 pounds (see Fig. 4). Rubbing strips shall be a minimum height of 2 7/8 inches and set back from the ends of the skids a distance of 2 1/2 to 4 inches to allow for sling placement. All rubbing strips shall be applied with two staggered rows of thirty penny nails spaced 12 inches apart in each row with a minimum of 4 nails required for each rubbing strip."

3.4.1, renumber to "3.4.2."

3.4.2.1, delete last sentence and substitute: "For gross loads over 150 pounds, rubbing strips (3.4.1.2) shall be used."

Page 11

Between 3.4.6.5 and 3.5.1 add new paragraph: "3.5 Type III Crates."

Footnote 1/ bottom of page, after word "Table" add "IV."

Page 18

Footnote 1/ bottom of page, delete "preproduction," substitute "first article."

Page 19

3.7.2.3.2.1, delete "Table VIII," substitute "Table III."

Page 27

3.9.1.1, delete "250," substitute "150."

Page 28

3.9.2.1, line 5, delete "locaged," substitute "located."

Page 32

3.13, line 3, delete "preproduction," substitute "first article."

Between 3.14 and 4.1 add new paragraph: "4. Quality Assurance Provisions."

Page 33

4.2.2, delete and substitute: "4.2.2 First Article Inspection Samples. One container of each design for which approval is desired shall be subjected to the preliminary First Article Inspection tests specified in 4.4.2. After successful completion of the preliminary tests, the samples shall be subjected to the final First Article Inspection tests specified in 4.4.3 unless otherwise specified by the procuring activity (see 6.2)."

MIL-C-25731A (USAF)
AMENDMENT 1

- 4.3a, delete "preproduction test" and substitute "First Article Inspection."
- 4.4, line 1, delete "Preproduction Test," substitute "First Article Inspection."
- 4.4, line 2, delete "preproduction," substitute "first article."
- 4.4.1, first line, delete "preproduction test" and substitute "First Article Inspection."
- 4.4.2, first line, 2 places delete "preproduction test" and substitute "First Article Inspection."
- 4.4.2.1, first line, delete "preproduction test" and substitute "First Article Inspection."
- 4.4.2.2, first and last line, delete "preproduction test" and substitute "First Article Inspection."

Page 34

- 4.4.3, first line, two places delete "preproduction test" and substitute "First Article Inspection."
- 4.4.3.1, delete "preproduction test" and substitute "First Article Inspection."
- 4.4.3.2, delete "preproduction test" and substitute "First Article Inspection."
- 4.6.1.1, add "Preliminary First Article Inspection." after 4.6.1.1 also first line delete "preproduction test" and substitute "First Article Inspection."
- 4.6.1.2, add "Final First Article Inspection." after 4.6.1.2 also delete "preproduction test" and substitute "First Article Inspection."
- 4.6.1.2.1, add "Live Load," after 4.6.1.2.1 also delete "preproduction test" and substitute "First Article Inspection."
- 4.6.2, delete "Acceptance Test." and substitute "Quality Assurance."

Page 35

- 4.6.2.1, delete "Examination of Product." and substitute "Inspection Method."
- 4.6.2.2, add "Quality Conformance." after 4.6.2.2.
- 4.6.2.3, add "Examination." after 4.6.2.3.

Page 37

- 4.6.4.1, delete method "216" and substitute "5007."

MIL-C-25731A (USAF)
AMENDMENT 1

4.6.4.2, delete method "213" and substitute "5008."

4.6.4.3, delete method "214" and substitute "5005."

4.6.4.4.1, delete method "211" and substitute "5023."

4.6.4.4.2, delete method "212" and substitute "5012."

4.6.5.1, delete method "209" and substitute "5016."

4.6.5.2, delete method "210" and substitute "5017."

Page 38

4.6.7.2, delete method "239" and substitute "5015."

4.6.7.3, delete method "278" and substitute "5019."

5.1, delete "specific" and substitute "specific."

Page 39

6.2h, delete "preproduction" and substitute "First Article Inspection."

6.2i, delete "preproduction" and substitute "First Article Inspection."

6.2l, delete "preproduction" and substitute "First Article Inspection."

Page 43

30.1.1, line 1, delete "four", substitute "three."

30.1.1, line 2, 3 delete "(c) to prevent edgewise movement, or (d) to prevent sidewise movement of the part." Substitute "(c) to prevent lateral movement of the part."

Page 46

40.1, delete and substitute: "40.1 General. The primary function of cushioning material when used in the packaging of aircraft control surfaces is to protect the thin skin surfaces against abrasion at the points of contact with the blocking."

Page 50

Figure 4, delete and substitute revised "Figure 4."

MIL-C-25731A (USAF)
AMENDMENT 1

Custodian:

Air Force - 69

Reviewer:

Air Force 10, 70, 71, 80, 82, 84

User:

Army - GL

Preparing Activity:

Air Force - 69

Project Number:

8115-F261

MIL-C-25731A (USAF)
 AMENDMENT 1

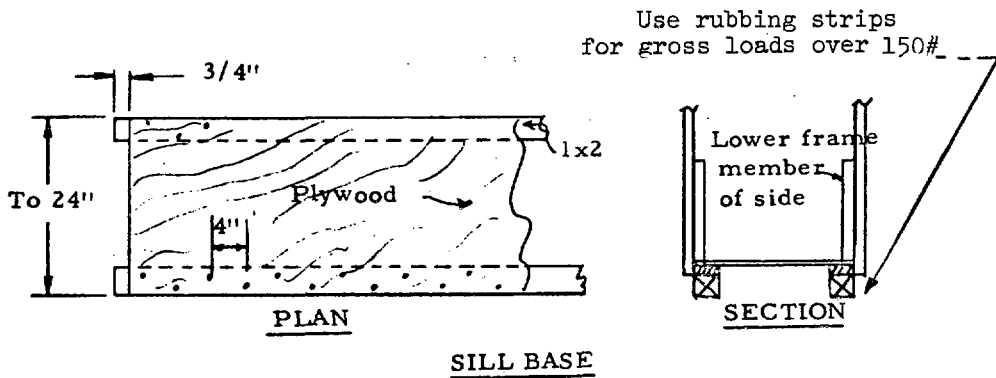
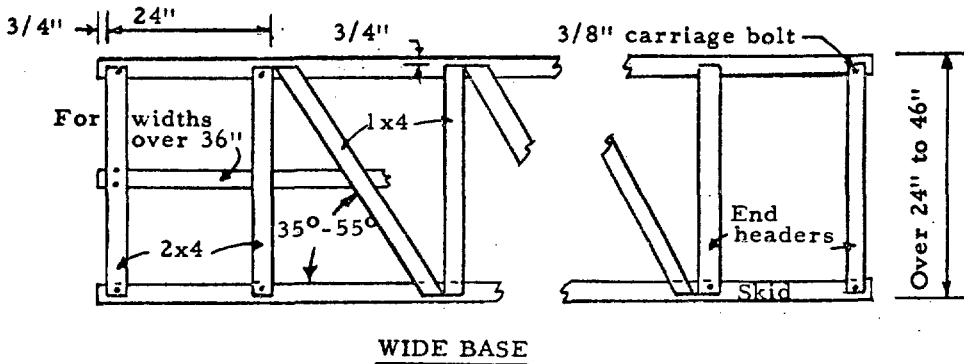
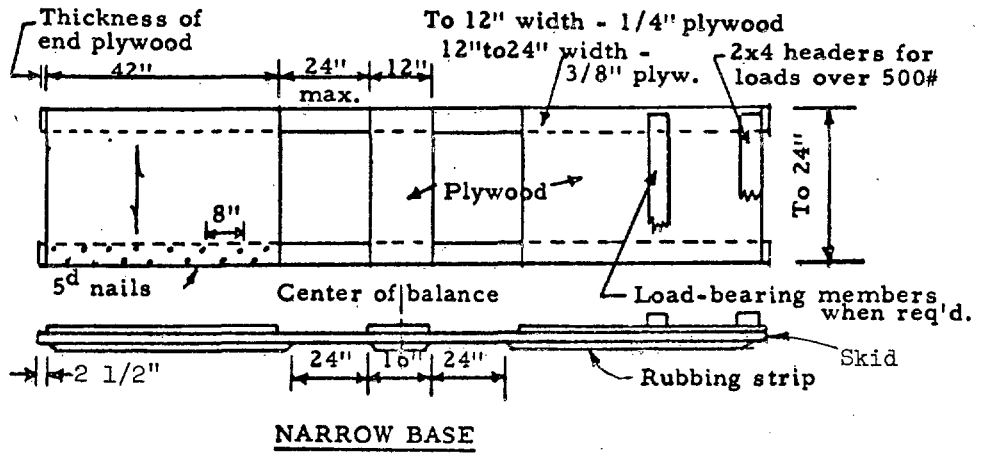

FIGURE 4 - TYPE II CRATE - BASE