

INCH-POUND

MIL-C-24758(SH)

5 August 1991

**MILITARY SPECIFICATION**  
**CONDUIT, FLEXIBLE, WEATHERPROOF, AND ASSOCIATED FITTINGS**  
**GENERAL SPECIFICATION FOR**

This specification is approved for use by the Naval Sea Systems Command, Department of the Navy, and is available for use by all Departments and Agencies of the Department of Defense.

1. SCOPE

1.1 Scope. This specification covers the general requirements for flexible, weatherproof conduit and associated fittings primarily for use in external areas on U.S. Navy Ships to shield cables against electromagnetic radiations from own-ship transmitters and from an electromagnetic pulse (EMP).

1.2 Classification. Conduit and fittings shall be provided as specified in 6.2.

2. APPLICABLE DOCUMENTS

2.1 Government documents.

2.1.1 Specifications standards and handbooks. The following specifications, standards and handbooks form a part of this document to the extent specified herein. Unless otherwise specified, the issues of these documents shall be those listed in the issue of the Department of Defense Index of Specifications and Standards (DODISS) and supplement thereto, cited in the solicitation (see 6.2).

Beneficial comments (recommendations, additions, deletions) and any pertinent data which may be of use in improving this document should be addressed to: Commander, Naval Sea Systems Command, SEA 5523, Department of the Navy, Washington, D.C. 20362-5101 by using the self-addressed Standardization Document Improvement Proposal (DD Form 1426) appearing at the end of this document or by letter.

AMSC N/A

FSC 5975

DISTRIBUTION STATEMENT A. Approved for public release; distribution is unlimited.

MIL-C-24758(SH)

SPECIFICATIONS

FEDERAL

- PPP-B-636
  - PPP-F-320
  - QQ-A-225/8
  - QQ-A-591
  - QQ-A-601
  - QQ-B-626
  - QQ-P-35
  - QQ-S-763
- Boxes, Shipping, Fiberboard.
  - Fiberboard, Corrugated and Solid, Sheet Stock (Container Grade) and Cut Shapes.
  - Aluminum Alloy 6061, Bar, Rod, Wire & Special Shapes; Rolled, Drawn Or Cold Finished.
  - Aluminum alloy Die Castings.
  - Aluminum alloy Sand Castings.
  - Brass, Leaded and Nonleaded: Rod, Shapes, Forging, and Flat Products with Finished Edges (Bar and Strip).
  - Passivation Treatments for Corrosion-Resistant Steel.
  - Steel Bars, Wire, Shapes & Forgings, Corrosion Resisting.

MILITARY

- MIL-P-116
  - MIL-R-6855
  - MIL-L-19140
  - MIL-C-83488
- Preservation, Methods Of.
  - Rubber, Synthetic Sheets, Strips, Molded or Extruded shapes-General Specification For.
  - Lumber and Plywood, Fire Retardant Treated.
  - Coating, Aluminum, Ion Vapor Deposited.

## MIL-C-24758(SH)

## STANDARDS

## MILITARY

- |                |   |
|----------------|---|
| MIL-STD-163    | - Steel Mill Products, Preparation for Shipment and Storage.  |
| MIL-STD-167/1  | - Mechanical Vibrations of Shipboard Equipment (Type I - Environment And Type II - Internally Excited). |
| MIL-STD-202    | - Test Methods for Electronic and Electrical Component Parts  |
| MIL-STD-1285   | - Marking of Electrical and Electronic Parts.   |
| MIL-STD-2073-1 | - DOD Material Procedures for Development and Application of Packaging Requirements.                    |

(Unless otherwise indicated, copies of federal and military specifications, standards, and handbooks are available from the Standardization Documents Order Desk, Building 4D, 700 Robbins Avenue, Philadelphia, PA 19111-5094.)

## SUPPLEMENT

See Supplement 1 for list of applicable specification sheets.

2.2 Non-Government publications. The following documents form a part of this document to the extent specified herein. Unless otherwise specified, the issues of the documents which are DOD adopted shall be those listed in the issue of the DODISS specified in the solicitation. Unless otherwise specified, the issues of documents not listed in the DODISS are the issue of the documents cited in the solicitation (see 6.2).

## AMERICAN SOCIETY FOR TESTING AND MATERIALS (ASTM)

ASTM B 33 - Standard Specification For Tinned Soft or Annealed Copper Wire for Electrical Purposes.

ASTM D 3951 - Standard Practice for Commercial Packaging (DOD Adopted).

(Application for copies should be addressed to the American Society for Testing and Materials, 1916 Race Street, Philadelphia, PA 19103-1137.)

## MIL-C-24758(SH)

(Nongovernment standards and other publications are normally available from the organizations that prepare or distribute the documents. These documents also may be available in or through libraries or other informational services.)

2.3 Order of precedence. In the event of a conflict between the text of this document and the references cited herein (except for associated detail specifications, specification sheets or MS standards), the text of this specification shall take precedence. Nothing in this specification, however, supersedes applicable laws and regulations unless a specific exemption has been obtained.

### 3. REQUIREMENTS

3.1 Specification sheets. The individual item requirements shall be as specified herein and in accordance with the applicable specification sheets. In the event of conflict between the requirements of this specification and the specification sheets, the latter shall govern.

3.2 First article. When specified (see 6.2), a sample shall be subjected to first article inspection (see 6.4) in accordance with 4.3.

3.3 Quality conformance. The manufacturer shall inspect an initial production sample from each production lot for agreement with the quality conformance requirements of 4.4 prior to regular production on a contract.

#### 3.4 Design and construction.

3.4.1 Conduit. Conduit shall be designed and constructed in accordance with this specification and the individual specification sheet. The conduit shall consist of: a core; a wire overbraid; and a jacket of synthetic rubber for waterproofing, marked on the outside with identification information. Construction of the core shall be in the form of a helical or an annular convolute for flexibility. Seams in the core shall be sealed for watertightness and shielding integrity.

3.4.2 Fittings and adapters. Fittings and adapters shall be designed and constructed in accordance with this specification and the individual

## MIL-C-24758(SH)

specification sheet. Fittings and adapters shall be able to withstand normal handling incident to installation and maintenance in service.

3.5 Materials. Materials shall conform to the applicable specifications as specified herein. However, when a specific material is not identified a material shall be used which will enable the conduit, fittings and adapters to meet the performance requirements of this specification.

3.5.1 Conduit.

3.5.1.1 Core. If the core is used for shielding the core material shall be selected to provide the electromagnetic shielding requirements of 3.7.1. The core shall be of convolute construction to allow for flexing or bending. Dimensions of the core shall be in accordance with the applicable specification sheet. Core design and manufacture shall ensure a smooth inner wall that will not abrade cable jackets when cables are routed within the conduit.

3.5.1.2 Braid. If braid is used for electromagnetic shielding, it shall provide optical coverage to meet the shielding requirements of 3.7.1. Braid shall be in accordance with ASTM B 33 and shall be applied with sufficient tension so that there will be no looseness or bunching of the braid on the core.

3.5.1.3 Jacket. The jacket shall be of synthetic rubber conforming to class 2, type A, grade 40 of MIL-R-6855. The jacket shall be of a uniform thickness, applied concentrically over the core, and free from pitting and blistering.

3.5.2 Fittings and adapters.

3.5.2.1 Materials. Fittings and adapters shall be fabricated from: corrosion resistant steel (CRES) in accordance with QQ-S-763, class 316; brass (B) in accordance with QQ-B-626; or aluminum (A) in accordance with QQ-A-225/8, QQ-A-591, or QQ-A-601. Other corrosion resistant materials may be used for fittings and adapters, subject to approval. Fitting and adapter material shall be specified by the procuring activity (see 6.2).

3.5.2.2 Finish. Finish material for aluminum fittings and adapters shall be in accordance with MIL-C-83488. CRES fittings shall be passivated in

## MIL-C-24758(SH)

accordance with QQ-P-35 or electro polished. Fitting dimensions shall apply after finishing (see 3.6.1). Brass fittings do not require a finish.

3.5.3 Visual inspection. On visual inspection of components, they shall be free from all foreign substances, such as grit, dirt, oil, and water.

3.5.4 Recovered materials. Unless otherwise specified herein, all material incorporated in the products covered by this specification shall be new and may be fabricated using materials produced from recovered materials to the maximum extent practicable without jeopardizing the intended use. The term "recovered materials" means materials which have been collected or recovered from solid waste and reprocessed to become a source of raw materials, as opposed to virgin raw materials. None of the above shall be interpreted to mean that the use of used or rebuilt products is allowed under this specification unless otherwise specifically addressed.

3.6 Physical characteristics.

3.6.1 Sizes and dimensions. The sizes and dimensions, including tolerances, for the conduit, fittings and adapters shall be as specified in the individual specification sheets. (see 6.2).

3.6.2 Conduit lengths. Conduit shall be furnished in the length or lengths specified by the procuring activity (see 6.2).

3.6.3 Interchangeability. All conduit, fittings and adapters manufactured to this specification and having the same part number shall be interchangeable with each other. Failure of any combination of different manufacturers conduits, fittings and adapters to meet the interchangeability requirements of 4.4.2.1 shall constitute cause for rejection.

3.7 Performance characteristics.

3.7.1 Electromagnetic shielding. Electromagnetic shielding tests shall be conducted as specified in 4.4.2.5 .

3.7.2 Watertightness. When tested, as specified in 4.4.2.6 the conduit, fittings and adapters shall show no evidence of water leakage within the conduit, fittings and adapters.

## MIL-C-24758(SH)

3.7.3 Salt spray (Corrosion). When tested as specified in 4.4.2.7 the conduit, fittings and adapters shall show no evidence of corrosion.

3.7.4 Temperature. When tested, as specified in 4.4.2.8, the conduit, fittings and adapters shall show no evidence of water leakage, internal or external damage or loss of shielding as a result of the test.

3.7.5 Vibration. When tested as specified in 4.4.2.9, fitting parts shall remain tight and intact.

3.7.6 Shock. When tested as specified in 4.4.2.10, fitting parts shall remain tight and intact.

3.7.7 Pull-out. When tested as specified in 4.4.2.11 the mechanical connection between the end fitting and the conduit shall not separate.

### 3.8 Marking.

3.8.1 Conduit. The jacket of all conduits shall be marked with an identifying legend consisting of the wording "EMI/EMP SHIELDING CONDUIT", the conduit part or identifying number (PIN) (see 6.5), and the manufacturer's name repeated at intervals not exceeding 2 feet. The size of the lettering shall not be less than 0.125 inch nor more than 0.250 inch, printed with white ink in block character type, remain legible after abrasion caused by normal handling of the conduit, and shall not be obliterated by the action of petroleum base oils, fuels, hydraulic fluids, or water.

3.8.2 Fittings and adapters. Each fitting and adapter part or identifying number (PIN) (see 6.5) and the manufacturers name shall be legibly and permanently marked on the fitting in accordance with MIL-STD-1285.

3.9 Workmanship. Every detail of manufacture shall be in accordance with the best practices for manufacture of flexible conduit, fittings and adapters. The conduit, fittings and adapters shall be free from all defects that could adversely affect installation, appearance, or long term use.

## MIL-C-24758(SH)

## 4. QUALITY ASSURANCE PROVISIONS

4.1 Responsibility for inspection. Unless otherwise specified in the contract or purchase order, the manufacturer is responsible for the performance of all inspection requirements (examinations and tests) as specified herein. Except as otherwise specified in the contract or purchase order, the manufacturer may use his own or any other facilities suitable for the performance of the inspection requirements specified herein, unless disapproved by the Government. The Government reserves the right to perform any of the inspections set forth in the specification where such inspections are deemed necessary to ensure supplies and services conform to prescribed requirements.

4.1.1 Responsibility for compliance. All items shall meet all requirements of sections 3 and 5. The inspection set forth in this specification shall become a part of the manufacturer's overall inspection system or quality program. The absence of any inspection requirement in this specification shall not relieve the manufacturer of the responsibility of ensuring that all products or supplies submitted to the Government for acceptance comply with all requirements of the contract. Sampling inspection, as part of the manufacturing operations, is an acceptable practice to ascertain conformance to requirements, however, this does not authorize submission of known defective material, either indicated or actual, nor does it commit the Government to accept defective material.

4.2 Classification of inspections. The inspection requirements specified herein are classified as follows:

- a. First article inspection (see 4.3)
- b. Quality conformance inspection (see 4.4)

4.3 First article inspection. First article inspection shall be performed as specified (see 3.2, 6.3, and 6.4). This inspection shall include the examinations and tests listed in table I.

4.3.1 First article samples. One test sample of each size conduit, with end fitting shall be tested. Unless otherwise specified, a test sample shall include a section of conduit and a fitting assembled together.



## MIL-C-24758(SH)

4.3.2 Sequence of first article inspection. Samples shall be tested as specified in table I.

TABLE I. First article inspections.

Inspection	Requirement Paragraph	Test Paragraph	Classification of Defects <u>1/</u>
Materials	3.5	4.4.2.2	Critical
Sizes and dimensions	3.6.1	4.4.2.1	Critical
Interchangeability	3.6.3	4.4.2.1	Critical
Electromagnetic shielding	3.7.1	4.4.2.5	Critical
Watertightness	3.7.2	4.4.2.6	Critical
Salt spray (corrosion)	3.7.3	4.4.2.7	Major
Temperature	3.7.4	4.4.2.8	Critical
Vibration	3.7.5	4.4.2.9	Major
Shock	3.7.6	4.4.2.10	Major
Pull out	3.7.7	4.4.2.11	Major
Marking	3.8	4.6	Minor
Workmanship	3.9	4.5	Major

- 1/ Critical defect - A defect likely to result in hazardous or unsafe conditions for individuals; or is likely to prevent performance of the tactical function of a major end item such as an aircraft communications system, or main part thereof.
- Major defect - A defect, other than critical, likely to result in failure or reduce materially the usability of the product for its intended purpose.
- Minor defect - A defect not likely to reduce materially the usability of the product for its intended purpose, or is a departure from established standards having little bearing on the effective use or operation of the product.

4.3.3 Number of units to be tested. A first article sample of each size conduit, fitting, or adapter delivered under this specification shall be tested as specified by the procuring activity. Any changes to the materials or product design delivered under this specification that deviate from the samples tested shall automatically require retesting and recertification of product samples.

## MIL-C-24758(SH)

4.4 Quality conformance inspection. Quality conformance inspection shall be performed by the manufacturer on conduits, fittings and adapters being offered for acceptance (see 6.3). This inspection shall include the examination and tests listed in table II.

TABLE II. Quality conformance inspections.

Inspection	Requirement Paragraph	Test Paragraph	Classification of Defects
Materials	3.5	4.4.2.2	Critical
Visual inspection	3.5.3	4.4.2.3	Major
Sizes and dimensions	3.6.1	4.4.2.1	Critical
Interchangeability	3.6.3	4.4.2.1	Critical

4.4.1 Inspection lot. An inspection lot is defined as items of the same type, size, material, and style produced at the same facility using the same components, production processes and equipment.

4.4.1.1 Quality conformance inspection sampling. As a minimum, the manufacturer shall inspect a sample quantity of conduits, fittings and adapters in accordance with the sampling plan defined in this paragraph. If one or more defects is found in any sample, the entire lot shall be rejected and screened 100 percent by the manufacturer for the defect found. Sample size depends on classification of the defect as shown in tables I and II. The sample size for each defect is shown in table III.

TABLE III. Sample lot size.

Lot Size	Critical Defect	Major Defect	Minor Defect
2 to 8	All	All	3
9 to 15	All	All	3
16 to 25	All	20	3
26 to 50	All	20	5
51 to 90	All	20	6
91 to 150	125	20	7
151 to 280	125	20	10
281 to 500	125	47	11
501 to 1200	125	47	15
1201 to 3200	125	53	18
3201 to 10,000	192	68	22
10,001 to 35,000	294	77	29
35,001 to 150,000	294	96	29
150,001 to 500,000	345	119	29
500,001 and over	435	143	29

## MIL-C-24758(SH)

4.4.2 Testing.

4.4.2.1 Physical inspection. Measurements shall be made on the conduit, fittings and adapters to determine compliance with physical requirements. Any dimension that is not within the specified tolerance, in accordance with 3.6, shall be classified a defect .

4.4.2.2 Materials inspection. Materials inspection shall consist of certification that the materials listed in the individual specification sheets were used in fabricating the delivered flexible conduit, fittings and adapters.

4.4.2.3 Visual inspection. Visual inspections shall be made on each fitting, adapter and length of conduit to verify that there are no gaps, cracks, breaks or other defects in material construction or workmanship. Any defects or failure to meet the requirements specified in 3.5, 3.5.3, and 3.9 shall be corrected or shall constitute cause for rejection.

4.4.2.4 Torque requirements. Prior to any testing, the conduit-to-fitting junction shall be tightened to the specified torque requirements of table IV for each size sample. This torquing is required to ensure electrical continuity for electromagnetic shielding and to ensure watertightness.

TABLE IV. Conduit to fitting torque values.

CONDUIT SIZE CODE	FITTING TORQUE VALUE (INCH POUNDS)
02	45
03	55
04	65
05	70
06	75
08	85
10	90
12	100
16	115
20	125
24	130

4.4.2.5 Electromagnetic shielding. To determine the electromagnetic shielding capability of conduit, fittings and adapters electromagnetic

## MIL-C-24758(SH)

shielding tests shall be performed on each size conduit and conduit fitting requested, to meet the criteria specified in Appendix A.

Electromagnetic shielding (surface transfer impedance) shall not exceed the values shown in table V over a frequency range of 10 kHz to 100 MHz.

TABLE V. Conduit and conduit fitting maximum transfer impedance.

CONDUIT		TRANSFER IMPEDANCE
NOMINAL ID inches	SIZE CODE	milliohms/foot
0.25	02	9.14
0.375	03	6.1
0.5	04	4.57
0.625	05	3.66
0.75	06	3.05
1.0	08	2.29
1.25	10	1.83
1.5	12	1.52
2.0	16	1.14
2.5	20	0.91
3.0	24	0.76
CONDUIT FITTING		TRANSFER IMPEDANCE milliohms
all sizes		5.0

4.4.2.6 Watertightness. To determine conformance to 3.7.2 a sample section of each size conduit requested (see 6.2), with a fitting attached, shall be tested for watertightness in accordance with method 104A of MIL-STD-202. Any detection of migration of water or moisture penetration shall constitute cause for rejection.

4.4.2.7 Salt spray (Corrosion). To determine conformance to 3.7.3 a lot sample of each size conduit, fittings and adapters shall be tested for resistance to corrosion in accordance with method 101D, test condition A of MIL-STD-202. Detection of failure in resistance to corrosion in the lot sample metals and protective coatings shall constitute cause for rejection.

4.4.2.8 Temperature cycling. To determine conformance to 3.7.4, a sample of each size conduit requested (see 6.2) with a proper size fitting attached shall be tested in accordance with method 107D of MIL-STD-202. Changes in electrical characteristics of the sample due to

## MIL-C-24758(SH)

mechanical displacement or rupture of insulating materials shall constitute cause for rejection.

4.4.2.9 Vibration. To determine conformance to 3.7.5, a sample shall be attached to a vibration table and tested in accordance with method 204C test condition B, of MIL-STD-202 and in accordance with the endurance test of MIL-STD-167/1. Failure of the sample to remain intact and tight shall constitute cause for rejection.

4.4.2.10 Shock. To determine conformance to 3.7.6, the sample shall be tested in accordance with MIL-STD-202, method 207A. Failure of the sample to withstand shock and to remain intact and tight shall constitute cause for rejection.

4.4.2.11 Pull-out. To determine conformance to 3.7.7, the sample shall be tested in accordance with method 211A, test condition A of MIL-STD-202. The force applied to the sample shall be 150 pounds. Failure of the sample to remain intact shall constitute cause for rejection.

4.4.2.12 Additional (repeat) tests. To determine the effects of tests 4.4.2.7, 4.4.2.8, 4.4.2.9, 4.4.2.10 and 4.4.2.11 on electromagnetic shielding and watertightness, the electromagnetic shielding test (see 4.4.2.5) and the watertightness test (see 4.4.2.6) shall be repeated on each sample after the above specified tests have been accomplished. Failure of the sample to pass the repeat tests shall constitute cause for rejection.

4.5 Visual examination. In preparation for packaging and delivery all parts supplied under this specification shall be inspected and shall be free from all foreign substances, such as grit, dirt, oil, and water. The ends of each length of conduit shall be protected to prevent entrance of foreign material and fraying of the braid.

4.6 Inspection of packaging. Sample packs and the inspection of the preservation, packing and container marking for shipment, stowage and storage shall be in accordance with the requirements of section 5 and the documents specified herein.

## 5. PACKAGING

(The packaging requirements specified herein apply only for direct Government acquisition. For the extent of applicability of the packaging or

## MIL-C-24758(SH)

the preparation for delivery requirements of referenced documents listed in section 2, see 6.6.)

5.1 GENERAL.

5.1.1 Navy fire-retardant requirements.

5.1.1.1 Lumber and plywood. When specified (see 6.2), all lumber and plywood including laminated veneer material used in shipping container, reel, spool, and pallet construction, members, blocking, bracing, and reinforcing shall be fire-retardant treated material conforming to MIL-L-19140 as follows:

Level A and B -

Type II - weather resistant  
Category I - general use.

Level C -

Type I - non-weather resistant  
Category I - general use

5.1.1.2 Fiberboard. Fiberboard used in the construction of interior (unit and intermediate) and exterior fiberboard boxes including interior packaging forms shall conform to the domestic/fire-retardant class or weather resistant/fire-retardant class materials requirements as specified (see 6.2) in PPP-F-320 and amendments thereto.

5.1.2 Cleaning and drying. Conduit and associated fittings shall be cleaned and dried by a process and procedure that will ensure that the items, internally and externally, are free of all foreign material that may affect its intended use and without damage to the item. The cleaning process and the drying procedure shall be in accordance with the requirements of MIL-P-116. Unless otherwise specified (see 6.2), selection of the cleaning process and drying procedure shall be at the supplier's option.

5.1.3 Preservatives. No preservatives, paints, or coatings shall be used on the conduit or the fittings.

5.2 Preservation. Preservation shall be level A, C or commercial as specified (see 6.2).

## MIL-C-24758(SH)

5.2.1 Level A.

5.2.1.1 Conduit. Conduit shall be furnished in straight lengths boxed, coiled or on spools or reels in the lengths specified (see 3.6.1). Ends shall be sealed to prevent entrance of foreign material. Straight lengths shall be individually wrapped with a neutral, waterproof kraft paper and secured to prevent unraveling. Unless otherwise specified (see 6.2), the quantity of straight lengths shall be limited to the weight limitations of the selected container. Lengths when furnished coiled, or on spools or reels shall be of a diameter to prevent bend radius of less than ten times the diameter of the conduit. Unless otherwise specified (see 6.2), boxes, coils, reels and spools including conduit wrapping shall be in accordance with MIL-STD-163. Fiberboard boxes shall be in accordance with PPP-B-636, Weather Resistant/Fire Retardant class and closed in accordance with method V of the appendix to the specification.

5.2.1.2 Fittings and adapters. Each fitting and adapter shall be unit protected within a transparent bag in accordance with MIL-P-116, method IC-1. Each method IC-1 unit bag shall be supplemented with a snug-fitting water resistant folding, set-up or metal edged paperboard or weather resistant/fire-retardant class fiberboard box at the manufacturer's option, in accordance with the unit container requirements of MIL-STD-2073-1. Box closure shall be in accordance with the box specification or appendix thereto except that the fiberboard boxes shall be closed in accordance with method V. Interior cushioning shall be provided, as necessary, to prevent item damage and puncture or damage to the protective unit bag. Unless otherwise specified (see 6.2), box options such as type, variety, grade and style shall be at the option of the manufacturer.

5.2.2 Level C.

5.2.2.1 Conduit. Preservation shall be as specified for level A except fiberboard boxes, when used, shall conform to domestic/fire-retardant class with closure in accordance with method I using pressure sensitive tape.

5.2.2.2 Fittings and adapters. Preservation shall be as specified for level A except:

MIL-C-24758(SH)

- a. The unit protection shall be by method IC-3, bag closure accomplished by twist-tie with plastic clips or plastic coated ties, and the leak and heat-seal tests are not required.
- b. The paperboard containers shall be of the domestic or non-weather resistant type, class, or variety as applicable and,
- c. The fiberboard containers shall be of the domestic/fire-retardant class material (see 5.1.1.2). The box closure shall be in accordance with method I using pressure sensitive adhesive tape.

5.2.3 Commercial. Commercial packaging shall be in accordance with MIL-STD-163 for conduits and ASTM D 3951 for fittings and adapters.

5.3 Packing. Packing shall be level A, B, C or commercial as specified (see 6.2).

5.3.1 General requirements for levels A, B, and C. Containers selected (see 5.3.1.1 and 5.3.1.2) shall be of minimum weight and cube consistent with the protection required, and of uniform size.

5.3.1.1 Conduit levels A, B, and C.

- a. Boxes. Overpacking of wood or plywood boxes containing straight length of wrapped conduit is not required. Fiberboard boxes are not authorized for level A packing and shall be overpacked in wood, plywood or wirebound boxes (see 5.3.1.2.1). Weather resistant/fire-retardant class fiberboard boxes are acceptable as a shipping container under levels B and C packing.
- b. Coils. Unless otherwise specified (see 6.2), wrapped and tied coils shall be individually boxed or grouped and secured on a skidded platform for shipment in accordance with MIL-STD-163 at the manufacturer's option.
- c. Spools. Spools shall be furnished in wood or plywood boxes in accordance with MIL-STD-163. When steel spools are furnished,



MIL-C-24758(SH)

separators shall be placed between the spools. Use of fiberboard boxes shall be as specified in 5.3.1.1.a.

d. Reels. Overpacking of reels is not required.

5.3.1.2 Fittings and adapters.

5.3.1.2.1 Levels A, B and C containers. Fittings and adapters preserved as specified (see 5.2), shall be packed in exterior shipping containers for the level of packing specified (see 5.3), in accordance with the exterior shipping container requirements of MIL-STD-2073-1 and herein. Unless otherwise specified (see 6.2), container selection shall be at the manufacturer's option.

5.3.1.3 Caseliners, closure and gross weight.

5.3.1.3.1 Caseliners. Unless otherwise specified (see 6.2), level A shipping containers containing fittings preserved level C or commercial shall be provided with waterproof caseliners in accordance with MIL-STD-2073-1.

5.3.1.3.2 Closure. Container closure, reinforcing, or banding shall be in accordance with the applicable container specification or appendix thereto except that the weather resistant class including fire-retardant fiberboard boxes shall be closed in accordance with method I using pressure sensitive tape.

5.3.1.3.3 Weight. Wood, plywood, and cleated type containers exceeding 200 pounds gross weight shall be modified by the addition of skids in accordance with MIL-STD-2073-1 and the applicable container specification or appendix thereto.

5.3.1.4 Commercial. Conduit and fittings preserved as specified (see 5.3) shall be packed for shipment as specified herein.

a. Conduit. In accordance with MIL-STD-163.

b. Fittings and adapters. In accordance with MIL-STD-2073-1.

5.3.1.4.1 Container modification. Shipping containers exceeding 200 pounds gross weight shall have a minimum of two, 3 inch by 4 inch nominal wood

## MIL-C-24758(SH)

skids laid flat, or a skid or sill type base which will support the material and facilitate handling by mechanical handling equipment during shipment, stowage and storage.

#### 5.4 Marking.

5.4.1 Levels A, B, C and commercial. In addition to any special marking required (see 6.2), interior packs, shipping containers, coils, reels and spools shall be marked including bar coding for shipment, stowage and storage in accordance with the following:

- (a) Conduit. In accordance with MIL-STD-163.
- (b) Fittings and adapters. In accordance with MIL-STD-2073-1.

#### 6. NOTES

(This section contains information of a general or explanatory nature that may be helpful, but is not mandatory.)

6.1 Intended use. The conduit, fittings and adapters covered by this specification are intended to shield topside electrical and electronic cables aboard U.S. Navy ships from the influence of external electromagnetic fields, that can be generated from on-ship transmitters or an EMP. The primary frequencies of interest are those between 10 kHz and 100 MHz.

6.2 Acquisition requirements. Acquisition documents must specify the following:

- (a) Title, number and date of this specification.
- (b) Issue of DODISS to be cited in the solicitation, and if required, the specific issue of individual documents referenced (see 2.1.1 and 2.2).
- (c) Conduit size and quantity required (see 3.6).
- (d) Fitting and adapter type (see 3.6) and quantity required.
- (e) First article inspection requirements to include electromagnetic shielding testing methods (see 3.2 and 4.3).
- (f) Part or Identifying Number (PIN) as defined on the specification sheet.
- (g) When fire-retardant lumber and plywood is required (see 5.1.1.1).

## MIL-C-24758(SH)

- (h) Class of fire retardant fiberboard required (see 5.1.1.2).
- (i) Cleaning and drying selections if other than the manufacturers option (see 5.1.2).
- (j) Level of preservation and level of packing required (see 5.2 and 5.3).
- (k) Quantity required per container if other than specified (see 5.2.1.1).
- (l) Boxes, coils, reels and spool if other than specified (see 5.2.1.1).
- (m) Container selections is other than the manufacturer's option (see 5.2.1.2 and 5.3.1.2.1).
- (n) Coils if other than individually boxed or grouped for shipment is other than the manufacturer's option (see 5.3.1.1.b).
- (o) When caseliners are not required (see 5.3.1.3.1).
- (p) Marking required (see 5.4).

6.3 Consideration of data requirements. The following data requirements should be considered when this specification is applied on a contract. The applicable Data Item Description (DID) should be reviewed in conjunction with the specific acquisition to ensure that only essential data are requested or provided and that the DIDs are tailored to reflect the requirements of the specific acquisition. To ensure correct contractual application of the data requirements, a Contract Data Requirements List (DD Form 1423) must be prepared to obtain the data, except where DOD FAR Supplement 27.475-1 exempts the requirement for a DD Form 1423.

<u>Reference Paragraph</u>	<u>DID Number</u>	<u>DID Title</u>
4.4	DI-MISC-80653	Test reports

The above DID was cleared as of the date of this specification. The current issue of DOD 5010.12-L, Acquisition Management Systems and Data Requirements Control List (AMSDL), must be researched to ensure that only current, cleared DIDs are cited on the DD Form 1423.

6.4 First article. The contracting officer should provide specific guidance to offerors on first article inspection requirements, whether the item(s) should be a preproduction sample, a first article sample, a first production item, a sample selected from the first production items, a standard production item from the manufacturer's current inventory (see 3.3), and the

## MIL-C-24758(SH)

number of items to be tested as specified in 4.3. The contracting officer should also include specific instructions in acquisition documents regarding arrangements for examinations, approval of first article test results, and disposition of first articles. Invitations for bids should provide that the Government reserves the right to waive the requirement for samples for first article inspection to those bidders offering a product which has been previously acquired or tested by the Government, and that bidders offering such products, who wish to rely on such production or test, must furnish evidence with the bid that prior Government approval is presently appropriate for the pending contract. Bidders should not submit alternate bids unless specifically requested to do so in the solicitation.

6.5 Part or identifying number (PIN). The PIN to be used for conduit and fittings acquired to this specification is created as indicated in each of the specification sheets.

6.6 Sub-contracted material and parts. The preparation for delivery or packaging requirements of referenced documents listed in section 2 do not apply when material and parts are acquired by the manufacturer for incorporation into the equipment or material and lose their separate identity when the equipment or material is shipped.

6.7 Subject term (key word) listing.

Electromagnetic interference (EMI)  
Electromagnetic pulse (EMP)  
Electromagnetic shielding

Preparing activity:  
Navy - SH  
(Project 5975-N651)

## MIL-C-24758(SH)

## APPENDIX A

## TEST PROCEDURE. TECHNICAL CONTENT REQUIREMENTS

## 10. SCOPE

10.1 Scope. This appendix covers the test procedure for testing transfer impedance of conduit. This appendix is a mandatory part of the specification. The information contained herein is intended for compliance.

## 20. APPLICABLE DOCUMENTS

This section is not applicable to this appendix.

## 30. TEST PROCEDURES

30.1 Test procedures. When required by the contract or order, the test procedures shall contain the following:

30.1.1 Conduit test fixture. Conduit shall be tested using the test fixture shown on figure 1. The conducting cylinder shall be fabricated from copper tube. Complete circumferential bonding shall be used at all pertinent joints of the test fixture, either by soldering or by machine screws placed not more than 11.8 inches apart. A 50 ohm load resistor with a maximum of 5 percent precision shall be connected between the input connector and the cable shield. A current source with a 50 ohm output impedance shall be used. The inner conductor may be the 0.1875 inches diameter rod used in 30.1.3 or any rigid, easily solderable transmission line centered inside the conduit. Total voltage drops across the joints and to ground of the test fixture shall be less than 1 percent of the voltage drop across the resistor. The drive current on the conduit shall be monitored externally by means of a power divider between the RF source and the test fixture.

30.1.2 Standard shield. A "standard shield" for calibration and instrumentation checkout shall be included as part of the test fixture. This standard shield shall be a piece of thin-wall brass tubing with a small aperture as shown in figure 2. The rod centered inside the tubing is the center conductor of a 50 ohm transmission line. One side of the "standard shield" shall be soldered to a type "N" connector. A machined brass plug to receive the banana connector shall be used to terminate the other end. The 0.125 inch diameter hole drilled at the halfway point of the tube gives a calibrated aperture from which the coupling shall be calculated. Figure 3 shows the calculated coupling (the absolute value of the transfer impedance,  $|Z_t|$ ) for a brass tube, both with and without the aperture. This behavior is described in appendix B.

## MIL-C-24758(SH)

## APPENDIX A

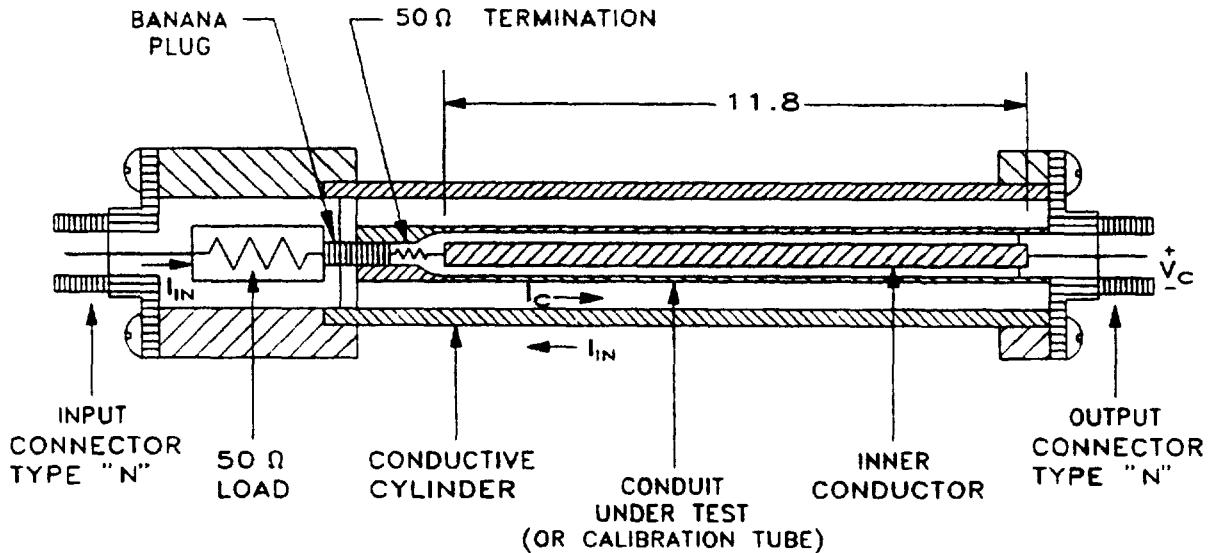
**NOTES:**

1. Dimensions are in inches.
2. This is a level 1 drawing IAW DOD-D-1000B

FIGURE 1. Conduit transfer impedance test fixture.

30.1.3 Conduit and fitting test fixtures. The test fixture for measuring a conduit and fitting assembly is shown in figure 4. A thin-wall tube, per dimensions in figure 2, shall be used to simulate a length of ideal (nonleaky) conduit for mating to the actual section of conduit on the fitting. The length of exposed conduit shall be as short as physically possible without letting the tube or any solder come in contact with the end of the fitting. All joints shall be circumferentially sealed to prevent RF leakage. An outer tube shall be used to shield the assembly from an external source of radiation. The modified test fixture used to measure the fitting assemblies with 90° and 45° bends must be approved by the procuring activity prior to testing.

30.1.4 Measuring techniques and test procedure. The test setup shown on figure 5 shall be used to measure the transfer impedance. Frequency measurements shall be made by driving the test fixture with a continuous wave (CW) signal and using narrow band detection techniques to measure the signal

## MIL-C-24758 (SH)

## APPENDIX A

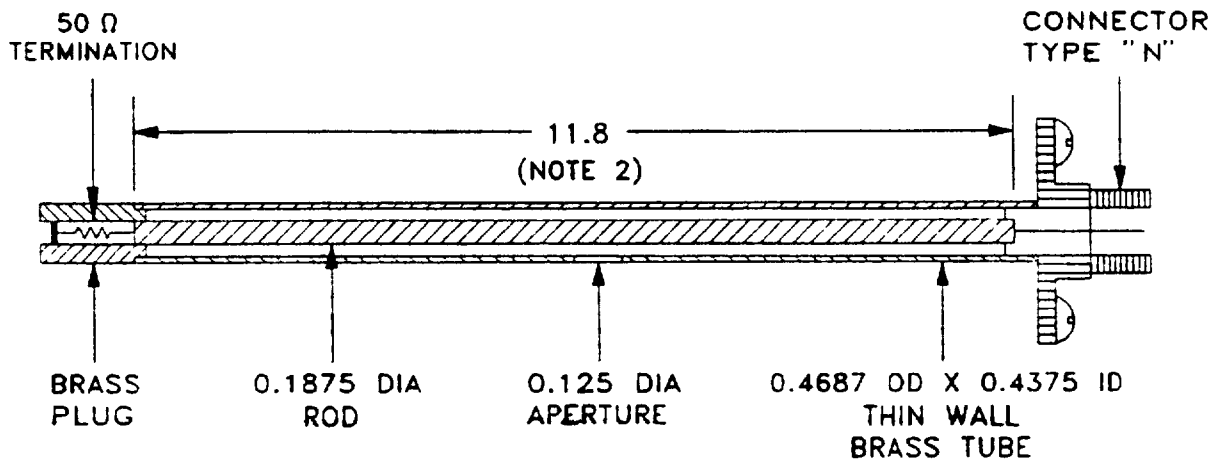
**NOTES:**

1. Dimensions are in inches.
2. For conduit and fitting assembly this dimension shall correspond to the length of the inner conductor that is illustrated in figure 4.
3. This is a level 1 drawing IAW DOD-D-1000B

FIGURE 2. Standard shield for calibration of test fixture.

MIL-C-24758(SH)

## APPENDIX A

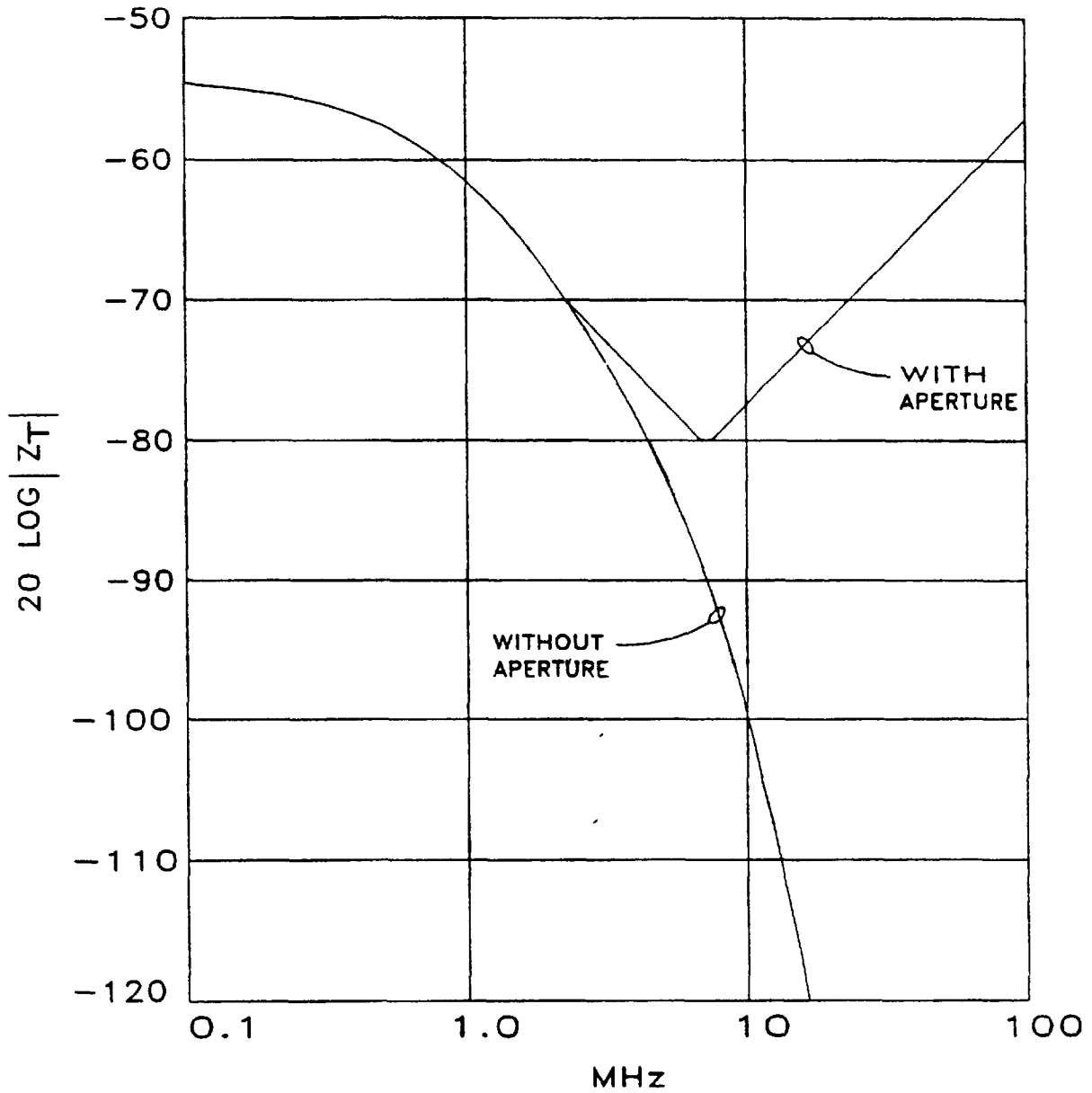
FIGURE 3. Transfer impedance coupling for the "standard shield."



## MIL-C-24758(SH)

## APPENDIX A

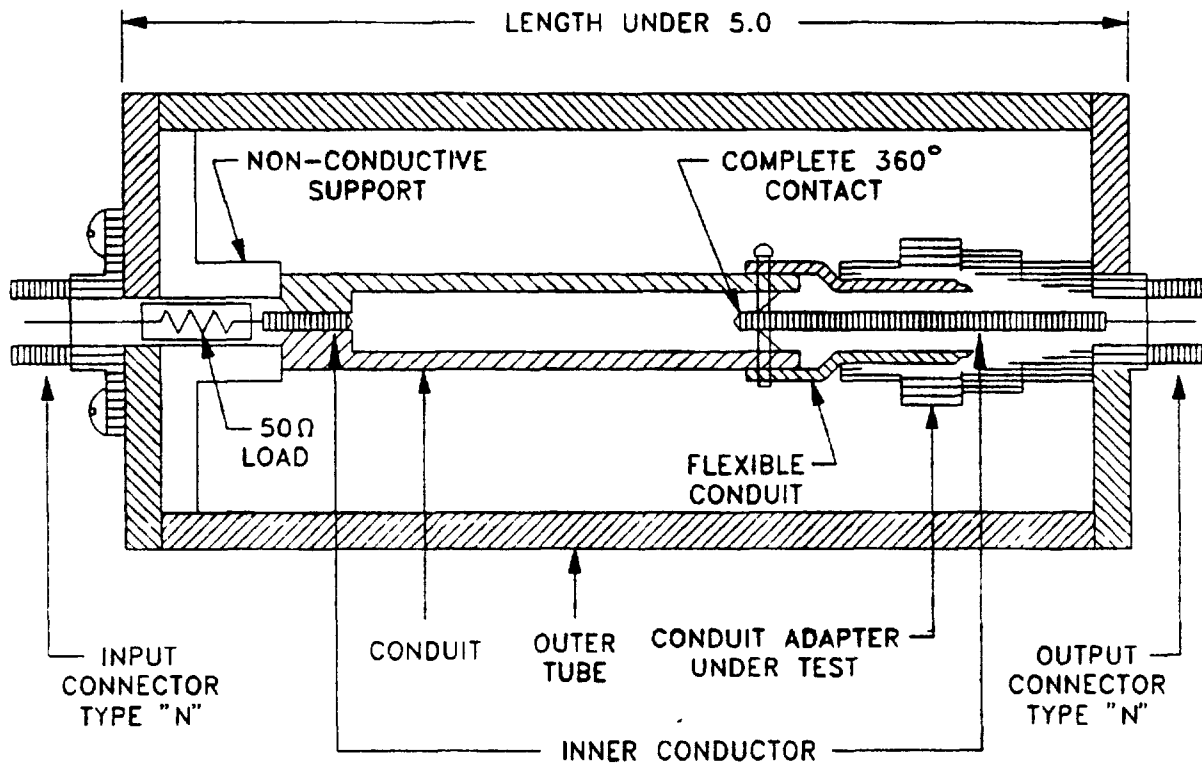
**NOTES:**

1. Dimensions are in inches.
2. This is a level 1 drawing IAW DOD-D-1000B

FIGURE 4. Test fixture for conduit and fitting assembly.

## MIL-C-24758(SH)

## APPENDIX A

coupled into the shield. This shall be done using swept CW frequencies with a network analyzer and a sweep oscillator. The transfer impedance shall be measured from 10 kHz to 100 MHz, unless a different frequency range is required by the test plan.

The oscillator output shall be connected to a power divider. One side of power divider's outputs shall connect directly to the input of the test fixture, while the other connects to the reference input of the network analyzer. An amplifier, if required, shall be connected directly to the fixture output connector. The generic test procedure shall be as follows:

- a. Set up the apparatus as shown on figure 5 by using the conduit transfer impedance test fixture as shown on figure 1 with the standard shield for calibration.
- b. Adjust the CW signal source to such level (typically 0 to 20 dBm) that the signal to noise ratio at the test input of the network analyzer will be at least 6 dB.
- c. Record the results measured by the network analyzer, while scanning the signal source in the entire required frequency range.
- d. Compare the measured transfer impedance of the calibrated test fixture to the graph in figure 3 in order to insure that the test setup is calibrated. This calibration graph shall be included in the test report.
- e. To measure the transfer impedance of a conduit, set up the apparatus as shown on figure 5, using the conduit transfer impedance test fixture as shown on figure 1.
- f. Repeat steps (b) and (c) for each conduit under test.
- g. To measure the transfer impedance of any conduit adapter, set up the apparatus as shown on figure 5, by using the test fixture for conduit and fitting assembly as shown on figure 4 after calibration of test assembly in step (a) through (d).
- h. Repeat steps (b) and (c) for each conduit fitting under test.

The resistance of the conduit of fitting assembly sample shall be measured using a milliohmmeter or other suitable technique compared to the low frequency transfer impedance. The two values shall match to within  $\pm 20$  percent ( $\pm 2$  dB) for the transfer impedance measurement to be acceptable.

30.1.5 Reporting. A logarithmic graphic presentation for each test specimen shall be provided as shown on figure 6. The logarithmic graphs shall illustrate the transfer impedance versus frequency. The graph shall include two plots, one of the test specimen test results and one of the calibration standard. Technical data on the instrumentation setup and the data acquisition method shall also be included in the test report.

MIL-C-24758 (SH)

APPENDIX A

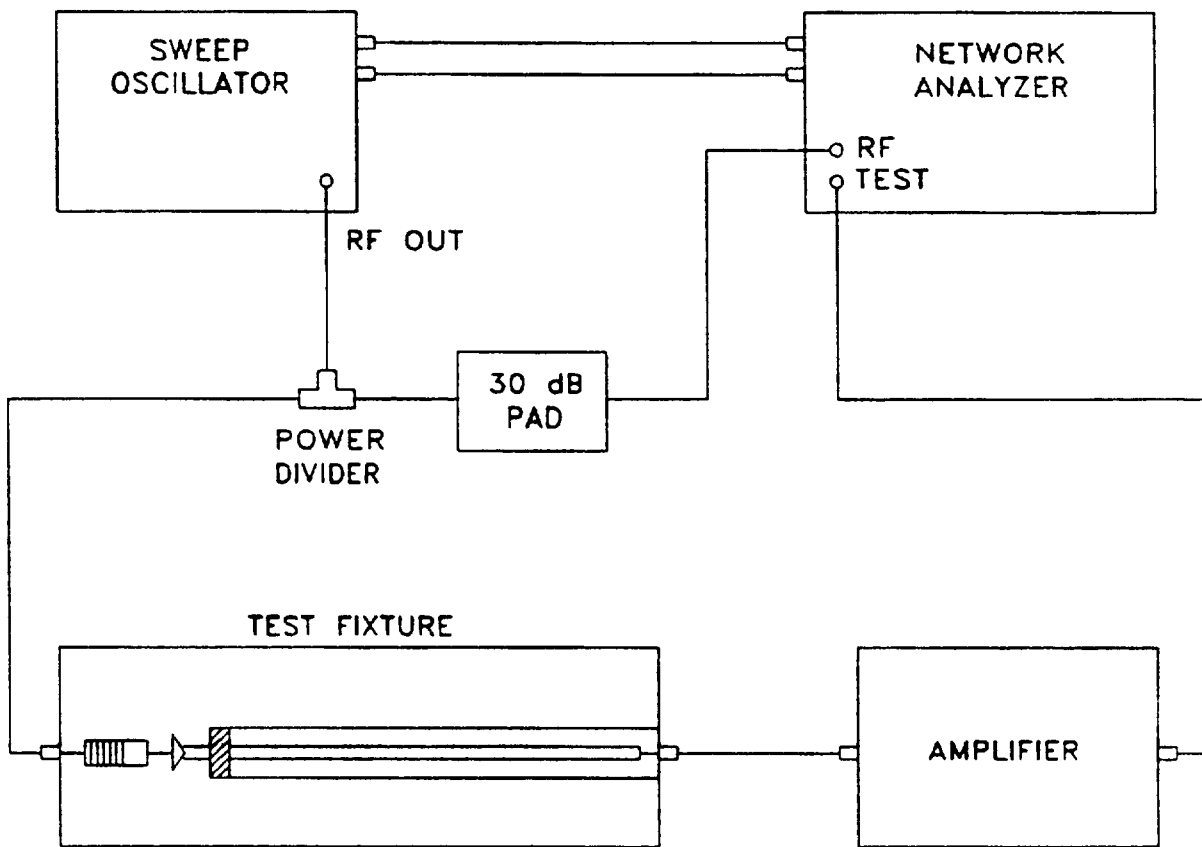

➤ **FIGURE 5. Generic test set-up for measuring conduit and conduit fitting assemblies.**

MIL-C-24758 (SH)

APPENDIX A

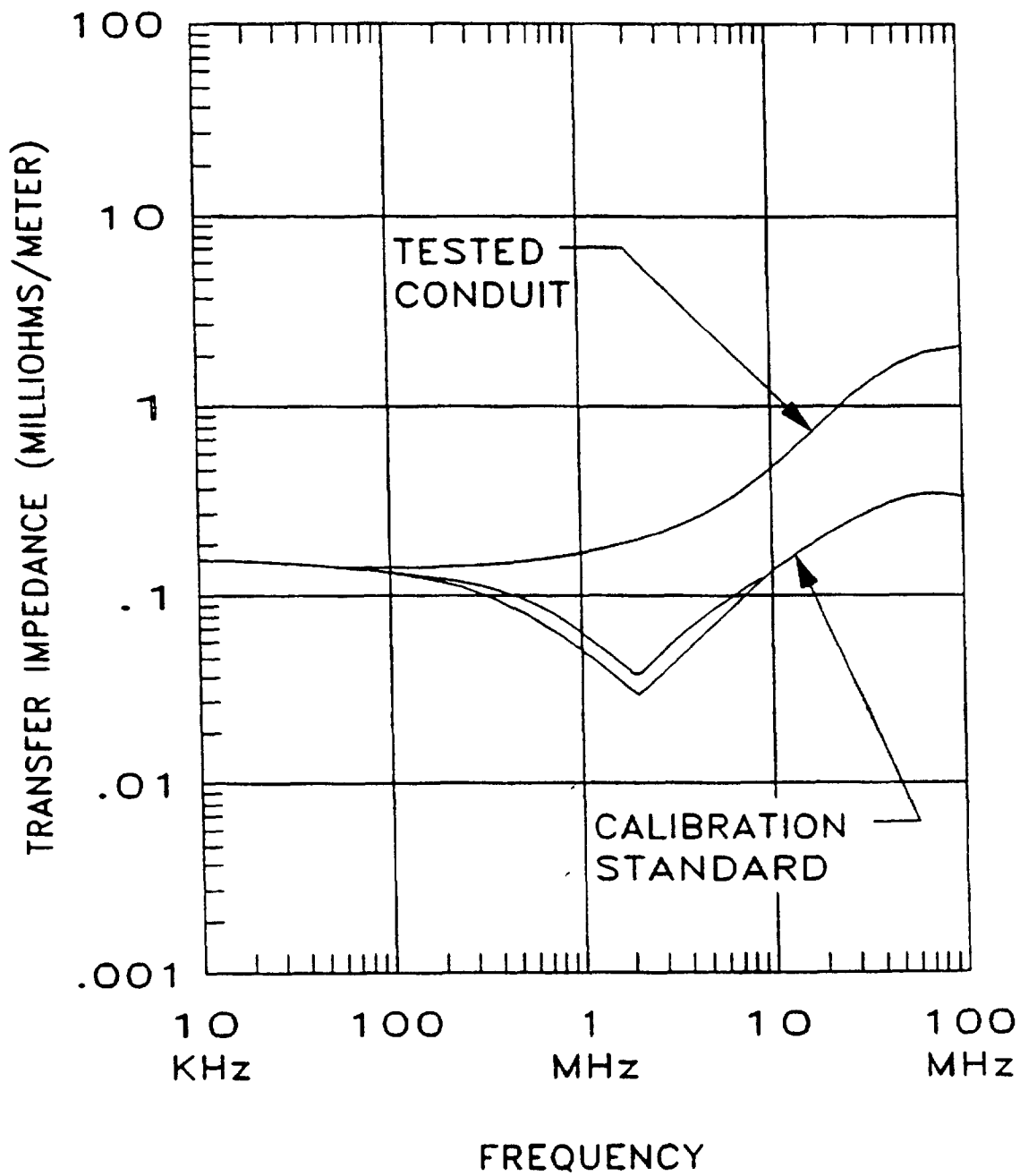

Figure 6. Sample surface transfer impedance graph.

## APPENDIX B

## TRANSFER IMPEDANCE THEORY

## 10. SCOPE

10.1 Scope. This appendix covers the transfer impedance theory of a conduit under test. This appendix is not a mandatory part of this specification. The information contained herein is intended for guidance only.

## 20. APPLICABLE DOCUMENTS

This section is not applicable to this appendix.

## 30. TRANSFER IMPEDANCE THEORY

30.1 Transfer impedance theory. When required the transfer impedance theory shall be as follows:

The transfer impedance of a conduit under test (or calibration tube) that was measured as shown below can be represented as a four terminal network.

The impedance matrix describing a two-port network is:

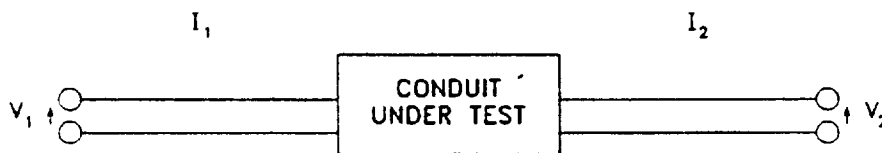

$$\begin{pmatrix} V_1 \\ V_2 \end{pmatrix} = \begin{pmatrix} Z_{11} & Z_{12} \\ Z_{22} & Z_{21} \end{pmatrix} \begin{pmatrix} I_1 \\ I_2 \end{pmatrix}$$

$$\begin{aligned} V_1 &= Z_{11} I_1 + Z_{12} I_2 \\ V_2 &= Z_{21} I_1 + Z_{22} I_2 \end{aligned}$$

Where, with reciprocity:  $Z_{21} = Z_{12}$

MIL-C-24758(SH)

## APPENDIX B

The transfer impedance  $Z_T$  is

$$Z_T = Z_{21} + j\omega L$$

$$Z_{21} = lR_o \frac{(1+j) T/\delta}{\text{Sinh}[(1+j) T/\delta]} = lR_o \frac{(1-j) T/\delta}{\text{Sin}(1-j) T/\delta}$$

$$j\omega L = j10^{-7} \frac{8r_o^3 f}{3b^2} (0.0254)$$

Where:

- $Z_{21}$  Represents the total coupling for the length  $l$  of tube due to diffusion through the tube.
- $j\omega L$  Represents the inductive coupling through the single circular aperture.
- $T$  Wall thickness of the tube (inches).
- $\delta$  Skin depth of the tube (inches) -  $(\mu\sigma\pi f)^{-1/2}$
- $\sigma$  Conductivity of the tube wall (Siemen/inch)
- $f$  Frequency of interest (Hz)
- $\mu$  Permeability of the tube metal (Hy/in)
- $R_o$  The DC resistance per unit length of the tube (ohm/in) -  $(2\pi b\sigma T)^{-1}$
- $b$  Inside tube radius (inches)
- $r_o$  Aperture radius (inches)

# STANDARDIZATION DOCUMENT IMPROVEMENT PROPOSAL

## INSTRUCTIONS

1. The preparing activity must complete blocks 1, 2, 3, and 8. In block 1, both the document number and revision letter should be given.
2. The submitter of this form must complete blocks 4, 5, 6, and 7.
3. The preparing activity must provide a reply within 30 days from receipt of the form.

**NOTE:** This form may not be used to request copies of documents, nor to request waivers, or clarification of requirements on current contracts. Comments submitted on this form do not constitute or imply authorization to waive any portion of the referenced document(s) or to amend contractual requirements.

<b>I RECOMMEND A CHANGE:</b>		1. DOCUMENT NUMBER MIL-C-24748 (SH)	2. DOCUMENT DATE (YYMMDD) 5 AUGUST 1991
3. DOCUMENT TITLE CONDUIT, FLEXIBLE, WEATHERPROOF, AND ASSOCIATED FITTINGS			
4. NATURE OF CHANGE (Identify paragraph number and include proposed rewrite, if possible. Attach extra sheets as needed.)			
5. REASON FOR RECOMMENDATION			
6. SUBMITTER		7. ORGANIZATION	
a. NAME (Last, First, Middle Initial)		b. ORGANIZATION	
c. ADDRESS (include Zip Code)		d. TELEPHONE (include Area Code)	e. DATE SUBMITTED (YYMMDD)
		(1) Commercial	
		(2) AUTOVON (if applicable)	
8. PREPARING ACTIVITY			
a. NAME COMMANDER NAVAL SEA SYSTEMS COMMAND		b. TELEPHONE (include Area Code)	(2) AUTOVON
ADDRESS (include Zip Code) WASHINGTON, DC 20362-5101 ATTN: SEA 06K211		(1) Commercial (703) 602-9121	(AU) 332-9121
		IF YOU DO NOT RECEIVE A REPLY WITHIN 45 DAYS, CONTACT Defense Quality and Standardization Office 5203 Leesburg Pike, Suite 1403, Falls Church, VA 22041-3466 Telephone (703) 756-2340 AUTOVON 289-2340	