

MIL-C-13486/6  
2 June 1964

MILITARY SPECIFICATION SHEET

CABLE, SPECIAL PURPOSE, ELECTRICAL: LOW TENSION;  
 HEAVY DUTY MULTIPLE CONDUCTORS UNSHIELDED

The complete requirements for procuring the cable described herein shall consist of this document and the issue in effect of Specification MIL-C-13486.

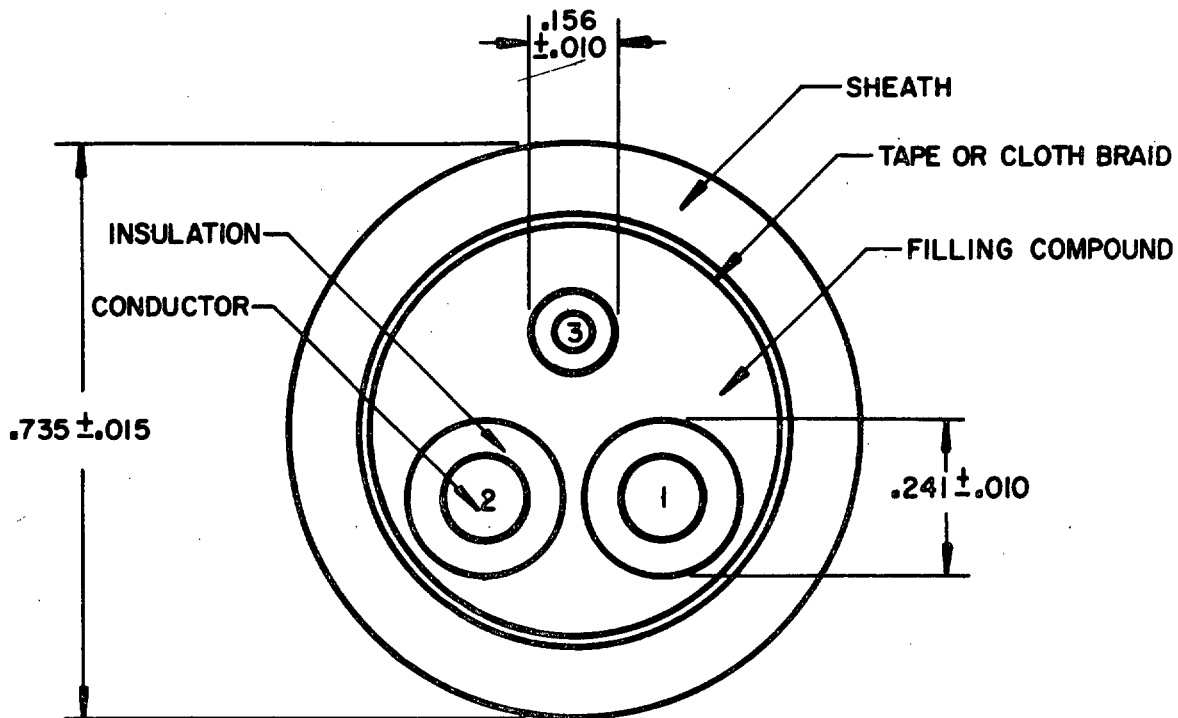

NOTE: All dimensions in inches.

REQUIREMENTS:

Dimensions and configuration: See above figure.

Conductor size: Conductors 1 and 2 are size 8 and conductor 3 is size 12  
 (See Table I of Specification MIL-C-13486).

Insulated conductors identification: See color code chart below.

FSC-6145

13486/6

Color code chart

Conductor		
No.	Base	Stripe
1	White	None
2	White	Black
3	Green	None

Part Number: M13486/6-1  
Former Part Number: 7056680

Custodian:  
Army - AT  
Navy - SH

Preparing activity:  
Army - AT

Reviewer interest:  
Navy - SH

Project No. 6145-0290

## STANDARDIZATION DOCUMENT IMPROVEMENT PROPOSAL

(See Instructions - Reverse Side)

1. DOCUMENT NUMBER

2. DOCUMENT TITLE

3a. NAME OF SUBMITTING ORGANIZATION

4. TYPE OF ORGANIZATION (Mark one)

 VENDOR USER MANUFACTURER OTHER (Specify): \_\_\_\_\_

b. ADDRESS (Street, City, State, ZIP Code)

5. PROBLEM AREAS

a. Paragraph Number and Wording:

b. Recommended Wording:

c. Reason/Rationale for Recommendation:

6. REMARKS

7a. NAME OF SUBMITTER (Last, First, MI) - Optional

b. WORK TELEPHONE NUMBER (Include Area Code) - Optional

c. MAILING ADDRESS (Street, City, State, ZIP Code) - Optional

8. DATE OF SUBMISSION (YYMMDD)

**INSTRUCTIONS:** In a continuing effort to make our standardization documents better, the DoD provides this form for use in submitting comments and suggestions for improvements. All users of military standardization documents are invited to provide suggestions. This form may be detached, folded along the lines indicated, taped along the loose edge (*DO NOT STAPLE*), and mailed. In block 5, be as specific as possible about particular problem areas such as wording which required interpretation, was too rigid, restrictive, loose, ambiguous, or was incompatible, and give proposed wording changes which would alleviate the problems. Enter in block 6 any remarks not related to a specific paragraph of the document. If block 7 is filled out, an acknowledgement will be mailed to you within 30 days to let you know that your comments were received and are being considered.

**NOTE:** This form may not be used to request copies of documents, nor to request waivers, deviations, or clarification of specification requirements on current contracts. Comments submitted on this form do not constitute or imply authorization to waive any portion of the referenced document(s) or to amend contractual requirements.

(Fold along this line)

(Fold along this line)

DEPARTMENT OF THE ARMY



NO POSTAGE  
NECESSARY  
IF MAILED  
IN THE  
UNITED STATES

OFFICIAL BUSINESS  
PENALTY FOR PRIVATE USE \$300

**BUSINESS REPLY MAIL**  
FIRST CLASS PERMIT NO. 12062 WASHINGTON D. C.

POSTAGE WILL BE PAID BY THE DEPARTMENT OF THE ARMY

Commander  
US Army Tank-Automotive Command  
ATTN: DRSTA-GSS  
Warren, MI 48080

