

MIL-C-11133D

19 June 1974

SUPERSEDING

MIL-C-11133C

27 June 1968

## MILITARY SPECIFICATION

## CRATES, SHIPPING, WOOD, OPEN, WIREBOUND

This specification is approved for use by all Departments and Agencies of the Department of Defense.

## 1. SCOPE

1.1 Scope. This specification, and appendix thereto, covers wirebound wooden crates of slatted construction for net weights not exceeding 1000 pounds.

1.2 Classification. Wirebound crates covered by this specification shall be of the following types, classes, styles, grades, and processes, as specified (see 6.2):

- |          |  |
|----------|--|
| Type I   | - Overwrap, no ends                                  |
| Type II  | - Conventional                                       |
| Class 1  | - Wired ends   |
| Class 2  | - Batten ends  |
| Type III | - Upright, all mechanical handling,<br>two way entry |
| Class 1  | - Interlocking base                                  |
| Class 2  | - Flush base   |
| Class 3  | - Channel base                                       |
| Style 1  | - Twisted wire closure                               |
| Style 2  | - Looped wire closure                                |

FSC 8115

## MIL-C-11133D

- Grade A - Heavy duty
- Grade B - Light duty
- Process 1 - No preservative treatment required
- Process 2 - Container dip treated
- Process 3 - Lumber pressure treated

## 2. APPLICABLE DOCUMENTS

2.1 The following documents, of the issue in effect on date of invitation for bids or request for proposal, form a part of this specification to the extent specified herein:

## SPECIFICATIONS

## FEDERAL

- FF-N-105 - Nails, Wire, Brads and Staples
- NN-P-530 - Plywood, Flat Panel
- TT-W-546 - Wood Preservative; Acid Copper Chromate Mixture
- TT-W-550 - Wood Preservative; Chromated Copper Arsenate Mixture
- TT-W-571 - Wood Preservation: Treating Practices
- TT-W-572 - Wood Preservative, Water-Repellent

## STANDARDS

## MILITARY

- MIL-STD-105 - Sampling Procedures and Tables for Inspection by Attributes
- MIL-STD-129 - Marking for Shipment and Storage
- MIL-STD-731 - Quality of Wood Members for Containers and Pallets

(Copies of specifications and standards required by suppliers in connection with specific procurement functions should be obtained from the procuring agency or as directed by the contracting officer).

MIL-STD-731

### 3. REQUIREMENTS

3.1 Materials. Materials shall conform to the requirements specified and to the specifications and standards referenced herein or as specified in the contract or order.

3.1.1 Plywood. When plywood is used in the fabrication of open wire bound crates it shall conform to group A or B of NN-P-530, and shall conform to the minimum commercial standard grades in table I. The thickness of plywood shall be as specified in table IV. Plywood will not be permitted for vertical faceboards on type III crates unless a minimum of 8 inches in width.

TABLE I. Plywood-NN-P-530

Crate grade	Group A CS 35	Group B PS 1
A or B	Type I, grade 3-4	Standard interior with exterior glue

3.1.2 Wood. Wood members shall be made from lumber conforming to MIL-STD-731, except as otherwise specified herein. The wood species shall conform to group I, II, III, or IV of MIL-STD-731, as applicable.

3.1.2.1 Moisture content. The moisture content of solid wood members (at time of construction) shall conform to MIL-STD-731, except that the moisture content of cleats, battens and sawed faceboards shall be not less than 9 percent nor more than 18 percent, and the moisture content of veneer shall be not less than 9 percent nor more than 15 percent.

3.1.2.2 Grain divergence. Cross grain shall conform to MIL-STD-731. The divergence of grain in cleats, battens, skids, and liners shall be as specified for structural members. In sawed or veneer face boards, the divergence of grain shall be in accordance with nonstructural members.

3.1.2.3 Wane. Wane shall conform to MIL-STD-731, except that wane along any edge of a cleat, batten or skid will be permitted for the full length of the member, provided it does not exceed 3/8 inch in either direction from the edge of the member.

3.1.2.4 Checks, splits and shake. Checks, splits, and shake shall conform to MIL-STD-731 except as follows:

3.1.2.4.1 Cleats, battens and skids. Checks, splits, and shake that do not penetrate the thickness, and do not exceed 1/8 inch in width at surface point of member will be permitted.

MIL-C-11133D

3.1.2.4.2 Liners. Checks, splits, and shake occurring through the full thickness that are longer than one-half the length of the liner and which exceed 1/8-inch in width shall not be permitted.

3.1.2.4.3 Sawed or veneer boards. Checks and splits at the end of a member are permitted if the checks or splits do not interfere with the specified fabrication, stitching or nailing pattern and do not exceed one-quarter of the length of the piece.

3.1.2.5 Knots. Knots allowable in wood members of wirebound crates shall conform to MIL-STD-731 except as follows:

3.1.2.5.1 Cleats, battens, and liners. The diameter of any knot or knot-hole shall not exceed one quarter the width or depth of the cleat or batten and shall not be closer than 1-1/4 inch from the end of the member. No knot or knothole in any liner shall exceed 1/2 inch in diameter and shall not be closer than 1-1/4 inches from the end of the liner.

3.1.2.5.2 Sawed or veneer boards.

3.1.2.5.2.1 Sound knots. Sound knots shall not exceed 1-1/2 inches in diameter, shall not exceed one third the width of the board, nor be closer than 1 inch to any edge. Knot clusters shall not exceed 2 inches in diameter nor exceed one third the width of the board, whichever is less.

3.1.2.5.2.2 Loose knots and knotholes. Loose knots and knotholes shall not exceed 1-1/8-inches in diameter, shall not exceed 1/3 the width of the board, nor be closer than 1-inch to any edge of the board. There shall be not more than one loose knot or knothole per face board between adjacent binding wires. A knot cluster which contains a loose knot or knothole, shall not exceed 2 inches in diameter nor exceed 1/3 the width of the board, whichever is the less. Not less than 1/2-inch of clear wood shall separate a loose knot or knothole from another knot of the cluster.

3.1.3 Wire, binding. Binding wires shall be galvanized, annealed, carbon steel wire. Wire used for style 1 closures (see figure 7) shall meet the applicable ductility test in 4.4.2 and shall result in a closure conforming to the appendix of this specification. Wire used for style 2 closures (see figure 8) shall show no fracture after loop is completed. The galvanized coating on wire shall not flake or peel when tested in accordance with 4.4.1.

3.1.4 Staples. Staples shall be either divergent or convergent and shall be fabricated from low carbon steel wire and be galvanized. The galvanized coating shall be smooth and shall not flake or peel after testing in accordance with 4.4.1.



MIL-C-11133D

3.1.5 Nails. Nails of the types herein specified shall conform to FF-N-105.

3.2 Design.

3.2.1 Type and class.

3.2.1.1 Type I crates. Type I crates shall be designed for type 1 loads only (see 6.1.4.1) and shall conform to figure 1. Each section of the wire-bound blank shall have face boards at the extreme ends of the cleats.

3.2.1.2 Type II crates. Type II crates shall be designed for type 1 and type 2 loads only (see 6.1.4.1, 6.1.4.2 and 6.2). Each section of the wire-bound blank shall have face boards at the extreme ends of the cleats (see figure 2).

3.2.1.2.1 Class 1. Type II, class 1 crates shall conform in design to figure 2. Each crate shall have liner ends. Thickness of liner boards and end boards shall be not less than the thickness required for the blank, except that the thickness of the liner board need not exceed 1/4-inch. The gage of wire for the liner ends shall be 14 gage.

3.2.1.2.2 Class 2. Type II, class 2 crates shall conform in design to figure 3. Each crate shall have batten ends and the ends shall have batten adjacent to each long cleat of the assembled crate. Battens shall run parallel to the long cleats. The thickness of end boards shall be not less than the thickness required for the blank. When 1-1/8 inch square cleats are required the minimum thickness of the battens shall be not less than 1 inch. Other battens shall have a minimum width of 1-3/8 inches and minimum thickness of 3/4-inch.

\* 3.2.1.3 Type III crates. Type III, class 1, 2 or 3 crates shall be designed for any type load (see 6.1.4 through 6.1.4.3 and 6.2). Each section of the wirebound blank shall have face boards at the extreme ends of the cleats. Each section of the blank, where possible, shall have one or more diagonals forming a minimum angle of 14° with vertical members. Diagonals may be omitted for crates up to 500 pounds for type 1 or 2 loads only. Each base shall have sufficient boards, battens or skids to provide a minimum of 40 percent coverage of the base. The minimum width of boards on bases shall be 3-3/8 inches, except nonbearing intermediate members may be a minimum of 1-1/2 inches in width.

3.2.1.3.1 Class 1. Design of type III, class 1 crates shall conform to figure 4.

## MIL-C-11133D

3.2.1.3.2 Class 2. Design of type III, class 2 crates shall conform to figure 5.

3.2.1.3.3 Class 3. Design of type III, class 3 crates shall conform to figure 6.

3.2.2 Styles.

3.2.2.1 Style 1. Style 1 crates shall use the twisted wire closure conforming to figure 7. The ends of girth wires shall extend at least 2-1/4 inches beyond the edge of the slat.

3.2.2.2 Style 2. Style 2 crates shall use the looped wire closure conforming to figure 8. The length of looped fasteners on girth wires shall be such as to make satisfactory closure.

3.2.3 Grades.

3.2.3.1 Grade A. Grade A, heavy duty crates shall conform to grade A requirements specified in tables I through IX inclusive.

3.2.3.2 Grade B. Grade B, light duty crates shall conform to grade B requirements specified in tables I through IX inclusive.

3.2.4 Approval of special designs. When the weight of the contents require a crate not provided for in this specification, the design of the crate shall be approved by the procuring agency.

3.3 Construction. Construction specified herein shall apply to types I, II and III crates.

3.3.1 Wirebound blank.

- \* 3.3.1.1 Cleats. Cleats shall be of group II, III, or IV woods (see 3.1.2). Each cleat shall be a single piece of wood without any joints. The ends of cleats shall be mitered or mortised and tenoned, except butt end cleats shall be used for type III, class 1 crates. The width and thickness of edge cleats shall be as specified on the applicable figure. The tolerance on the width and thickness of cleats shall be plus 1/8 minus 1/32-inch. The distance between intermediate cleats, when required, shall not exceed the dimensions shown in table II. Any of the sizes of cleats shown in table III may be used for intermediate cleats, when required. Tolerances on width and thickness of intermediate cleats shall be plus 1/8 minus 1/32 inch. Intermediate cleats are not required on type I crates.

MIL-C-11133D

TABLE II. Requirements and spacing for rows of intermediate cleats, grades A and B use 1/

Grade A and B use		
Thickness of faceboards required for blank	Maximum distance between cleats	
	Type 2 load	Type 3 load
Inches	Inches	Inches
Less than 1/4	22	16
1/4	26	20
5/16	28	22
Over 5/16	32	27

1/ No intermediate cleats required for type I load.

TABLE III. Sizes of cleats for intermediate rows, grades A and B use

Width	Thickness
Inches	Inch
2-3/4	3/8
2-1/4	1/2
1-3/4	5/8
1-1/4	3/4
13/16	3/4

\* 3.3.1.2 Face and end boards. Face and end boards shall be limited to the woods permitted in 3.1.2. The thickness of face and end boards shall be as required by table IV. Plywood, as specified in 3.1.1, of the thickness specified for wood in table IV, shall be permitted. When plywood ends are used in type II, class 1 crates, the direction of the grain for the outer plies shall be vertical. When plywood ends are used in type II, class 2 crates, the direction of the grain, of the outer plies, shall be horizontal. When plywood is used as face boards and end boards other than specified herein, the direction of the grain of the outer plies shall run parallel to the length of the boards. No part of any wood face board shall be less than 95 percent of the specified thickness for face or end boards less than 1/4 inch thick. For wood face or end boards 1/4 inch thick or more, the tolerance shall be plus 1/8 minus 1/32 inch. No part of any plywood face or end boards shall be less than 95 percent of the thickness specified.

TABLE IV. Face board and end board thickness

Weight of contents		Type I crate		Type II crate		Type III crate		
Pounds Pounds exceeding	Inches not exceeding	Inches group I wood <u>1/</u>	Inches group II, III, IV wood	Inches group I wood <u>1/</u>	Inches group II, III, IV wood	Inches group I wood	Inches group II, III wood	Inches group IV wood
Grade A use:								
0	125	3/8	7/32	3/8	7/32		7/32	3/16
125	200		1/4		1/4		1/4	7/32
200	300						5/16	1/4
300	500						5/16	5/16
500	1000						3/8	3/8
Grade B use:								
0	125	5/16	1/6	5/16	1/6	3/8	7/32	3/16
125	200	3/8	3/16	3/8	3/16		1/4	7/32
200	300						5/16	1/4
300	500						5/16	5/16
500	1000						3/8	3/8

1/ The following species of group I woods of the same thickness permitted for group II and group III woods may be used: cottonwood, cypress, magnolia, fir (true firs), and spruce.



MIL-C-11133D

3.3.1.3 Binding wires. Binding wires shall be applied mechanically and shall be continuous around the girth of the crate. Wire shall conform to 3.1.3. The gage of wire and maximum spacing between wires shall be as specified in table V. The minimum number of wires shall be as specified in table VI. Where possible, a binding wire shall be stapled over each intermediate cleat.

TABLE V. Gage and spacing of binding wires for all uses

Weight of contents		Gage of wire <u>1/</u> Grade A and B	Maximum spacing in inches	
Exceeding	Not exceeding		Grade A	Grade B
Pounds	Pounds			
0	125	15	9	11
125	200	14	9	11
200	700	13	9	11
700	1000	12 Over cleats	10	12
		13 Over faceboard only		

1/ The gage of wires over cleats and intermediate wires shall be the same except as noted, or 700 to 1000 lbs. loads.

TABLE VI. Minimum number of binding wires for both grade A and grade B

Length along faceboard cleat to cleat (inches)	Minimum number of binding wires
Through 18	3
18-1/16 through 27	4
27-1/16 through 36	5
36-1/16 through 50	6
50-1/16 through 60	7
60-1/16 through 70	8
Over 70	9

MIL-C-11133D

3.3.1.4 Staples. Staples shall conform to 3.1.4, and table VII and VIIa.

TABLE VII. Minimum length and gage of staples - grade A or B

Size of edge cleat	Thickness of faceboards	Length and gage of staples					
		Group II wood cleats		Group III wood cleats		Group IV wood cleats	
Inches	Inches	Inches	Gage	Inches	Gage	Inches	Gage
13/16 x 7/8	7/32 to 3/8	1-1/4	16	1-1/4	16	1-1/8	16
1-1/8 x 1-1/8	Up to 1/4	1-1/2	15	1-1/2	14	1-1/4	14
1-1/8 x 1-1/8	5/16 to 3/8	1-1/2	15	1-1/2	14	1-3/8	14

TABLE VIIa. Minimum length and gage of staples - grade A or B

Combined thickness of faceboard and intermediate cleat or liner	Length and gage of staples			
	In boards only		In boards and over wires	
	Inches	Gage	Inches	Gage
3/16	3/8	20	7/16	20
1/4	3/8	20	7/16	20
5/16	7/16	18	7/16	18
3/8	1/2	18	9/16	18
1/2	11/16	18	3/4	18
3/4	7/8	16	7/8	16

3.3.1.5 Stapling over binding wires into cleats. Each binding wire shall be fastened by staples driven over binding wires, through face boards and through the cleats, and shall be sufficiently long to produce a smooth clinch.

MIL-C-11133D

Staples shall not be deformed or protrude from the sides of the cleats. The distance from the end of cleats at each corner to the first staple shall not exceed 1-5/8 inches. For the ends of the type II, class 1 crates, staples shall pass through the liner and the end faceboard and shall be clinched. The length and diameter of staples shall conform to requirements of table VII and VIIa.

3.3.1.5.1 Stapling over binding wires into face board only. Each binding wire shall be fastened by staples driven over binding wires into and through the face boards and clinched. Staples shall be spaced not more than 2 inches apart and not less than two staples per face board. Staples shall conform to the requirements of table VII and VIIa.

### 3.3.2 Tops.

\* 3.3.2.1 Battens for tops of the type III crates. Each top shall have a batten adjacent to and parallel to two opposite cleats of the blank. When possible, the top battens shall run parallel to the longest dimension of the top. When the distance between battens exceeds 14 inches, one or more intermediate battens shall be required. The distance between an intermediate batten adjacent to a cleat or between two intermediate battens shall not exceed 14 inches. Group I wood battens shall be not less than 1-3/4 inches wide. Group II, III and IV wood battens shall be not less than 1-3/8 inch wide. Battens shall be not less than 3/4 inch thick. No part of any batten shall be more than 1/32 inch below or 1/8 inch above the specified thickness nor more than 1/16 inch below or 1/8 inch above the specified width.

3.3.2.2 Face boards. Face boards for tops of types II and III crates shall conform to table IV.

\* 3.3.2.3 Assembly of tops. Face boards on tops of types II and III crates shall be fastened to each batten with staples not less than 16 gage, cement-coated or chemically-etched nails not less than 14-1/2 gage, or with clinched, uncoated nails. The length of the fastening for face boards 5/16 inch or less in thickness shall be not less than the thickness of the face boards plus 3/4 of the thickness of the battens. The points of the fasteners shall not protrude from the battens unless clinched. Face boards exceeding 5/16 inch thickness shall be attached to batten with nails having a minimum clinch of 1/8 inch or with staples having length equal to the combined thickness of face board and batten plus 1/4 inch. Face boards not exceeding 3-7/8 inches in width shall be fastened to each batten with not less than two nails or staples. Face boards exceeding 3-7/8, but not exceeding 5-5/8 inches in width shall be fastened to each batten with not less than three nails or staples. Face boards 5-5/8 to 7-1/2 inches in width shall be fastened to each batten with not less than four nails or staples. Nails or staples shall be spaced in accordance with commercial practice. Staples shall conform to 3.1.4 and nails shall conform to 3.1.5.

MIL-C-11133D

**3.3.3 Base.****3.3.3.1 Batten base.**

**3.3.3.1.1 Battens.** Battens shall be fabricated of group II, III or IV wood. No part of any batten shall be more than 1/32 inch below the specified thickness nor more than 1/16 inch below the specified width (see figures 2A and 3). Edges shall have a batten adjacent to and parallel to two opposite cleats of the blank. Where possible, battens shall be adjacent to longer cleats. When the distance between battens adjacent to cleats exceeds 14 inches, one or more intermediate battens shall be required. The distance between an intermediate batten and a batten adjacent to a cleat or between intermediate battens shall not exceed 14 inches.

\* **3.3.3.1.2 Boards.** Boards conforming to 3.1.1 and 3.1.2, of thickness specified in table VIII, shall be used for the bases. The tolerance on base boards shall be plus 1/8 inch or minus 1/32 inch on thickness and plus or minus 1/8 inch on width.

\* **3.3.3.1.3 Fasteners of base.** Base boards on base shall be fastened to battens or stringers with staples not less than 1 1/2 gage or with nails not less than 1 1/2 gage. The length of the nails used shall be such as to provide a clinch of 1/8 inch minimum. When the combined thickness of deck board and stringer exceeds 2 inches, drive screws or ring nails shall be used, of such length as to penetrate not less than 3/4 of the thickness of the stringer. When height of stringer is greater than 1-5/8 inches, a clinch shall not be required, but the minimum length of the nail shall be such that 3/4 of the shank shall penetrate into the skid. When the nails are not clinched, they shall be drive screw or ring shanked. When clinched, the length of the staples or nails shall be equal to the combined thicknesses of board and batten, plus a minimum of 1/8 inch. Boards shall be fastened to battens or skids with the number of fasteners per joint as specified below:

<u>Face boards width</u>	<u>Number of fasteners</u>
1-3/4 inches	1
2-5/8 inches, not exceeding 3-7/8 inches	2
3-7/8 inches, not exceeding 5-5/8 inches	3
5-5/8 inches, not exceeding 7-1/2 inches	4

Nails or staples shall be spaced in accordance with commercial practice. Two rows of fasteners shall be required for 3-5/8 inch wide stringers. Staples shall conform to 3.1.4 and nails shall conform to 3.1.5.



MIL-C-11133D

TABLE VIII. Thickness of sawed lumber for base boards, type III crates, all type loads

<u>Weight of contents</u>	<u>Wood groups II, III, IV grade A or B</u>
Pounds	Inches
0-125	3/8
125-200	5/8
200-300	3/4
300-500	7/8
500-1000	1-1/8

3.3.3.2 Stringer base (runners).

- \* 3.3.3.2.1 Stringers. Stringers shall be made from woods specified in 3.1.2 and shall have a height of not less than 1-5/8 inches. Stringers shall extend a minimum of 1/8 inch beyond the side panels of the assembled blanks. The size and spacing between stringers shall be as specified in table IX.

TABLE IX. Stringers (runners) - width and thickness, grade A or B <sup>1/</sup>

<u>Weight of contents</u>	<u>Width</u>	<u>Thickness</u>	<u>Maximum spacing</u>
Pounds	Inches	Inches	Inches
0-400	2-3/8	1-5/8	20
400-700	2-3/8	1-5/8	17
500-1000	2-3/8	2-5/8	14

- <sup>1/</sup> Minimum dimensions of stringers (runners) for type II, class 2 crates with weight of contents exceeding 200 pounds, but not exceeding 500 pounds, and for type III crates with contents not exceeding 1,000 pounds.

## MIL-C-11133D

3.4 Dimensions. Dimensions of crates furnished shall be inside measurements, as specified (see 3.2), and shall be cited in the sequence of length, width, and depth. The length dimension shall be the distance between the end panels of the crate; the width dimension shall be the distance between the side panels of the crate; and the depth dimension shall be the distance between the top and base panels of the crate. Dimensions shall be measured between the inner-most surfaces of opposite panels, see applicable figure.

\* 3.5 Marking for identification. Marking for identification shall be applied by the manufacturer and shall include box-maker's name and address or trademark and address, specification compliance data, type, class, style, and grade, maximum allowable weight of contents and type of load (see 6.1 through 6.1.4.3).

\* 3.6 Preservative treatment. When process 2 is specified, the entire crate shall be completely immersed or flushed for a minimum of one minute in a water repellent wood preservative conforming to type I or II, composition A or B of TT-W-572 and shall not discolor the dye when tested in accordance with 4.4.3. When process 3 is specified, all lumber and plywood shall be treated prior to fabrication with water-borne preservative treatment in conformance with TT-W-571, using wood preservatives conforming to TT-W-546 or TT-W-550. After treatment, lumber and plywood shall be dried to a minimum 13% and a maximum 19% of moisture content.

\* 3.7 Workmanship. The finished crate shall be square, clean, and free of loose or missing components and unclinked staples or nails.

#### 4. QUALITY ASSURANCE PROVISIONS

4.1 Responsibility for inspection. Unless otherwise specified in the contract or order, the supplier is responsible for the performance of all inspection requirements as specified herein. Except as otherwise specified in the contract or order, the supplier may use his own or any other facilities suitable for the performance of the inspection requirements specified herein, unless disapproved by the Government. The Government reserves the right to perform any of the inspections set forth in the specification where such inspections are deemed necessary to assure supplies and services conform to prescribed requirements.

4.2 Inspection. Sampling for inspection shall be performed in accordance with MIL-STD-105, except where otherwise indicated hereinafter.

#### 4.3 Inspection.

4.3.1 Component and material inspection. In accordance with 4.1 above, components and materials shall be inspected and tested in accordance with all the requirements of referenced specifications, drawings and standards unless otherwise excluded, amended, modified, or qualified in this specification or applicable purchase document.

MIL-C-11133D

4.3.1.1 Testing of components and materials. Tests shall be performed on representative samples from each lot of materials and components used in fabrication of the end item for the characteristics noted in table X. The number of sample units to be tested, randomly selected throughout the lot of the applicable component or material, shall be as indicated the table X. When testing for moisture content of wood, using the moisture meter method, the average of the three determinations taken on each sample unit shall represent the moisture content (percent) for the unit. All tests for characteristics noted in table X shall be reported on the results of each sample unit tested. Failure of any sample unit to meet the specified requirement of tolerance range shall be the basis for rejection of the end item lot fabricated therefrom.

TABLE X. Testing of components and materials

Component	Character- istic	Basic spec rqmt para	Test methods	Number determinations per sample unit	Results reported to nearest	Sample unit	Sample size
Cleats, battens, sawed faceboards, and veneer board	Moisture content	3.1.2.1	MIL-STD 731 Oven Method	1, after con- stant weight is attained	Percent	1 piece, not less than 9 square inches, weighing not less than 20 grams	5
			Moisture meter method 4.3.1.1	3	Percent	1 piece	5
Binding wire	Ductility	3.1.3	4.4.2	1	Pass or fail	2 pieces wire	5
Coating of binding wire	Adherence	3.1.3	4.4.1	1	Pass or fail	1 piece, 3 yds	5
Coating of stapling wire	Adherence	3.1.4	4.4.1	1	Pass or fail	1 piece, 3 yds	5



MIL-C-11133D

#### 4.3.2 Inspection of the end item.

4.3.2.1 Examination of the end item. Examination of the end item shall be in accordance with the classification of defects in table XI. The lot, for purposes of determining the sample size for examinations in 4.3.2.1.1 and 4.3.2.1.2, shall be in units of crates of the same type, class, style, grade, and size, and in units of bundles of palletized unit loads of knocked down crates, as applicable. The inspection levels and acceptable quality levels shall be as indicated in 4.3.2.1.5.

\* 4.3.2.1.1 Examination for visual defects. The sample unit for this examination shall be one completely assembled or knocked-down crate, with skid when applicable.

TABLE XI. Classification of defects

Examine	Defect	Classification	
		Major	Minor
Material	Wood group or combination of species not as specified		X
Cleats, battens, liners and skids	Fractures, cracked, or damaged		X
	Bark or wane on cleat exceeding 3/8 inch from any edge of member		X
	Bark or wane on batten exceeding 3/8 inch from any edge		X
	Any through check, split or shake longer than width of the member	X	
	Knots or knot holes in cleats and battens exceeding 1/4 the width or depth of cleat or batten and closer than 1-1/4 inch from the end		X
	Knot or knot hole in liner exceeding 1/2-inch in diameter or closer than 1-1/4 inch from the end		X
	Slope of grain exceeds 1 inch in 10 inches of length		X
	Cleat not single piece of wood		X
	Ends of cleat not mitered or mortised and tenoned (not applicable to type III, class 1 crate)	X	
	Cleats not butt ended on type III, class 1 crates	X	

MIL-C-11133D

TABLE XI. Classification of defects (cont'd)

Examine	Defect	Classification	
		Major	Minor
Face boards	Sound knot exceeding 1-1/2 inch in diameter or exceeding 1/3 the width of board		X
	Loose knots or knot holes exceeding 1-1/8 inch in diameter or more than one per face between adjacent binding wires		X
	Sound knots closer than 1 inch to any edge of the board	X	
	Not sawed lumber, veneer or plywood	X	
	Knot clusters exceed two inches in diameter or exceed 1/3 of the width of the board		X
	Decay in wood	X	
	Slope of grain exceeds 1 inch in 8 inches length in sawed lumber or veneer		X
	Thickness of face boards less than specified (see table III)	X	
	Grain of end face boards not vertical for type II, class 1 crates		X
	Grain of end face boards not horizontal for type II, class 2 crates		X
	Grain of plywood face boards not parallel to length of board		X
	Construction crate	Not type, class, style or grade specified	X
Any design or construction detail, including location of cleats, skids and battens, not as specified, except as otherwise classified herein (figures 1-7)		X	

MIL-C-11133D

TABLE XI. Classification of defects (cont'd)

Examine	Defect	Classification	
		Major	Minor
Binding wire and fasteners	Binding wire not continuous around girth of box	X	
	Fasteners and binding wires less than minimum number specified	X	
	Binding wires not fastened with staples as specified	X	
	Staples or nails not spaced as specified, or not clinched where required		X
	Nails not cement coated or chemi- cally etched when not clinched		X
	Staples or nails not fully driven		X
	Staple or nail points protruding	X	
Closures	Ends of girth wire extend less than 2-1/4 inches beyond edge of slate (figure 7)		X
	Loop closures and looped fasteners not as specified (figure 8)		X
Face board coverage	Total face board coverage less than 50 percent on each face, as applic- able		X
Marking for identification	Not legible or not as specified	X	
Workmanship	Out of square	X	
	Binding wire loose		X
	Missing component	X	
	Not clean		X

\* 4.3.2.1.2 Dimensional examination. Inspection shall be made to determine compliance with specified dimensions. Any deviation from specified dimensions shall constitute a defect.

\* 4.3.2.1.3 Testing of the end item. When applicable, one sample unit shall be selected at random from the lot offered for inspection and shall be tested in accordance with 4.4.3. Any evidence of failure shall be cause to reject the lot represented by the sample unit.

MIL-C-11133D

- \* 4.3.2.1.4 Examination of preparation for delivery. An examination shall be made to determine that the packaging, packing and marking comply with the section 5 requirements. Defects shall be scored in accordance with table XII. The sample unit for this examination shall be one bundle of knocked-down crates, or one palletized unit load when unit loads are specified. The lot shall be the number of bundles or unit loads in the end item inspection lot. The inspection level and acceptable quality level shall be as specified in 4.3.2.1.5.

TABLE XII. Preparation for delivery defects

Examine	Defect	Classification	
		Major	Minor
Bundle	Number of crates more than specified or indicated quantity	X	
	Not neatly, uniformly, and securely bundled		X
Unit loads (when specified)	Not palletized as specified	X	
Strapping	Less than three straps	X	
	Less than 5/8 inch width or 0.020 inch thick	X	
	Not flat steel strapping	X	
	Loose or not securely sealed	X	
Size of load	Not as specified	X	
Marking of bundles or palletized unit loads	Markings not placed on tags	X	
	Markings omitted, incomplete, incorrect, illegible, of improper size, location, sequence, or method of application		X

4.3.2.1.5 Inspection levels and acceptable quality levels for examinations. The inspection levels and acceptable quality levels (AQL's), expressed in terms of defects per hundred units, shall be as follows:

<u>Examination paragraph</u>	<u>Inspection levels</u>	<u>AQL's</u>	
		<u>Major</u>	<u>Total</u>
4.3.2.1.1	I	2.5	6.5
4.3.2.1.2	S-1		2.5
4.3.2.1.4	S-2	1.0	4.0



MIL-C-111133D

#### 4.4 Tests.

4.4.1 Adherence of galvanized coating on wire. The following tests shall be performed to determine the adherence of the galvanized coating on wire. The wire shall be wrapped in a closed helix for at least two complete turns, at a rate of not more than fifteen turns per minute, around a cylindrical mandrel 3/16 inch in diameter. After this operation, the coating shall not flake or be removed by rubbing the bare fingers over the wire on the mandrel.

4.4.2 Ductility of binding wire. Two pieces of binding wire shall be clamped in a vise and a twisting tool applied to the free ends of wire. The wire shall be twisted by the tool as specified below:

<u>Gage of wire</u>	<u>Amount of complete turns</u>
16	2-1/2
15	2
14	2
13	1-1/2
12	1-1/2

After completing the specified amount of turns, the tool shall be removed and the wire shall show no fracture when examined under a magnifying lens of minimum 3.0 x power. A typical twisting tool is illustrated in figure 7.

\* 4.4.3 Dryness of preservative. When dip treated, the assembled crate shall be placed on either end, with one end open. A red oil soluble dye mixture (see 6.4), shall be applied along the interior juncture of a cleat and the bottom section of the knocked down box. Observation shall be made for discoloration of the solution (red or deep pink) within 5 minutes of application when tested at 50°F or above. Discoloration shall be cause for rejection. When lumber or plywood is pressure treated, the quality assurance provisions of TT-W-571 shall apply.

### 5. PREPARATION FOR DELIVERY

#### 5.1 Packaging and packing, level C.

5.1.1 Bundling. Unless otherwise specified (see 5.1.2), wirebound crates shall be shipped knocked down to occupy a minimum amount of space and, where practicable, shall be tied with wire or metallic or nonmetallic strapping in bundles of not more than 10.

## MIL-C-11133D

5.1.2 Unit loads. When specified (see 6.1.1.1, knock down wire bound crates shall be shipped as a palletized unit load. The unit load shall be made of individual crates or bundles of 10 individual wirebound crates stacked to occupy a minimum amount of space. The load shall be strapped to the pallet with a minimum of three 5/8 inch by 0.020 inch flat steel straps drawn to maximum tension and sealed securely. Size of palletized load shall be such as to permit loading of minimum carload quantities by rail or truck. Palletized unit loads shall not exceed 2000 pounds.

- \* 5.2 Marking. In addition to any special marking required by the contract or order, shipments shall be marked in accordance with MIL-STD-129, utilizing tags (see 6.2).

## 6. NOTES

6.1 Intended use. Crates covered by this specification are intended for use in the domestic and overseas shipment of general material and supplies (other than fresh fruits and vegetables, dressed poultry and uncanned meats) not requiring the protection provided by boxes and particularly where light weight containers are desired. The engineering design of crates includes the consideration of normal stresses imposed on loaded crates by stacking, handling, fork lift trucks, as well as stresses on members encountered by drops. Use should be confined to the weight of contents limitations of the several types.

6.1.1 Grades.

6.1.1.1 Grade A. Grade A crates covered by this specification are primarily intended for rigorous shipment, repeated handling, protected and unprotected storage, and possible extreme climatic conditions. Grade A crates meet all requirements for overseas shipment.

6.1.1.2 Grade B. Grade B crates covered by this specification are primarily intended for normal shipping, handling and storage requirements where the additional strength of the grade A crate is not required.

6.1.2 Types.

6.1.2.1 Type I crates. Type I crates provide an economical means of overwrapping an item or fiberboard box to gain additional protection and stacking strength in shipment, handling and storage. Type I crates can be palletized for high stacking.

MIL-C-11133D

6.1.2.2 Type II crates. Type II crates are intended for use with type 1 and 2 loads (see 6.1.3.1 and 6.1.3.2), and where ends are desirable for additional protection of the end item. Class 1 crates with wired ends are easily assembled. Class 1 and class 2 crates are identical, except for the batten type end which provides additional resistance to stacking loads, particularly for crates of larger width. Batten type ends may be held in place behind the cleat framework of the crate by the load or nailed in place as desired.

6.1.2.3 Type III crates. Type III crates are intended for type 1, 2, or 3 loads (see 6.1.3 through 6.1.3.3), but are primarily designed for type 3 loads which lend no support to the faces of the crate. Variations of base construction permit a latitude of choice or preference, depending on the item to be packed and the desired method of assembling the wirebound blank to the base. Crates are intended for items such as refrigeration components, engines, machinery or like equipment. Items packed in type III crates would typically be bolted to the base. In conjunction with, or in lieu of bolting, metal strapping, wood blocks, braces, or combinations of methods shall be used to prevent movement of load within the crate.

6.1.3 Processes for preservation. The wood preservation used for process 2 crates will normally provide adequate protection against decay when adverse storage conditions will not exceed two years. The lumber preservative treatment used for process 3 crates will normally provide adequate protection against decay for adverse storage conditions up to fifteen years.

6.1.4 Types of loads. Type of load determined weight and size limitations applicable. The type of load falls in one of the following categories:

6.1.4.1 Type 1 (easy load). Articles of moderate density, packed in and completely filling one, and only one fiberboard box, which, in turn, completely fills and supports all the faces of the outer shipping crate into which it is packed; or a single article of moderate density which contacts and completely supports all the faces of the shipping crate and has sufficient strength, even though not crated, to withstand the forces encountered in transportation and handling, but required physical protection of the crate to prevent scratching or marring.

6.1.4.2 Type 2 (average load). Contents are moderately concentrated articles which may either be packed directly into the outer shipping crate or subjected to an intermediate stage of packing, such as wrapping or packing in a chipboard or fiberboard box or protected by other types of suitable interior packing. The contents or interior packing provide support for all the faces of the shipping crate.

MIL-C-11133D

6.1.4.3 Type 3 (difficult load). Contents are articles which are highly concentrated, require a high degree of protection, or do not support the shipping crate.

6.2 Ordering data. Procurement documents should specify the following:

- (a) Title, number and date of this specification.
- (b) Type, class, grade, style and process required (see 1.2).
- (c) Type of load for type II and III crates  
(see 3.2.1.2 and 3.2.1.3).
- (d) Inside dimensions (see 3.4).
- (e) Quantity of crates required (see 5.1.1).
- (f) When knocked down wirebound crates shall be shipped  
as a palletized unit load (see 5.1.2).
- (g) Weight of contents (see 5.1.2).
- (h) Special marking when required (see 5.2).

6.3 The margins of this specification have been marked with an asterisk (\*) to indicate where changes (additions, modifications, corrections, deletions) from the previous issue were made. This was done as a convenience only and the Government assumes no liability whatsoever for any inaccuracies in these notations. Bidders and suppliers are cautioned to evaluate the requirements of this document based on the entire content, irrespective of the marginal notations and relationship to the last previous issue.

\* 6.4 Formula for test solution. Red oil soluble dye 5% - Borax (60/200) - 95%.

NOTE: The red oil soluble dye (known as 7WB concentrate) may be obtained from the Keystone Aniline Company.

**Custodians:**

Army - GL  
Navy - SA  
Air Force - 69

**Preparing activity:**

Army - GL

Project No. 8115-0253

**Review activities:**

Army - EA, ME, SM, WC, WV  
Air Force - 70, 71, 82

**User activities:**

Navy - MC  
Air Force - 80



MIL-C-11133D

## APPENDIX

## Use of Wirebound Crates and Requirements

## For Assembling and Closure

## 10. SCOPE

10.1 This appendix covers requirements for assembling and closing wire-bound crates.

10.2 When commodities are furnished or shipped in crates conforming to this specification, they shall be cushioned, blocked, braced, or bolted to prevent movement within the crate. Articles having fragile legs or bases shall be suspended or supported within the crate. Articles with highly finished surfaces shall be cushioned, braced, or bolted to provide sufficient clearance between finished surfaces of the article and crate members to prevent marring, chipping, or other injury in transit. Articles subject to damage or deterioration from exposure to the elements shall be completely covered, before crating, with barrier material conforming to PPP-B-1055. The position of intermediate cleats and base boards shall be located considering item to be packed and requirements for blocking, bracing, or bolting.

## 20. APPLICABLE DOCUMENTS

20.1 The following document, of the issue in effect on date of invitation for bids or request for proposal, forms a part of this appendix to the extent specified herein.

## SPECIFICATION

## FEDERAL

PPP-B-1055 - Barrier Material, Waterproofed, Flexible

## 30. ASSEMBLING OF CRATES

30.1 Type I. Apply wirebound overwrap to carton and twist wires or closure loops in accordance with 40.

30.2 Type II.

30.2.1 Class 1. Class 1 crates shall be assembled by bending the looped end wires at right angles to the end, passing the loops through the notches in the cleats, and bending back the looped wire over and around the girth wire (fig. 9).



MIL-C-11133D

- \* 30.2.2 Class 2. Class 2 crates shall be assembled by nailing or stapling the end boards to the inside of each side cleat. Nails shall be not less than 0.076 inch diameter (14-1/2 gage) and staples shall be not less than 0.0625 inch diameter (16 gage). The length of each fastener shall be not less than the thickness of the end boards plus three quarters of the thickness of the cleats. The points of fasteners shall not protrude. The average spacing of fasteners shall not exceed 2-1/2 inches.

### 30.3 Type III.

30.3.1 Class 1 (fig 4). The front and back bottom cleats lock in under the overhanging baseboards. The top battens recess down inside the top cleats of the blank. Drive not less than two 2-1/2 inch drive screw nails adjacent to the wire, through the bottom cleat of the front and back sections, into the adjacent skid of the base. Drive not less than one 2-1/2 inch drive screw nail through the face board and cleat, at the center of each side section, into the adjacent base board or center skid. Secure the top by driving not less than two 2-1/2 inch drive screw nails through each top cleat into the adjacent batten of the top.

- \* 30.3.2 Class 2 (fig 5). The bottom side cleats shall abut the base members. The bottom cleats of the front and back sections shall rest on top of the base skids. The top battens shall recess down inside the top cleats of the blank. The nailing requirements of 30.3.1 shall apply.

- \* 30.3.3 Class 3. All the bottom cleats of the wirebound blank shall recess into a channel provided by the overhanging top and bottom base boards. Top battens shall recess down inside the top cleats of the blank. The nailing requirements of 30.3.1 shall apply.

## 40. CLOSING OF CRATES

40.1 Style 1. Style 1 twisted wire closures shall be closed by using special hand tools available from any crate supplier. For best performance it is essential the correct twist be achieved. Closure shall conform to requirements of figures 7 and 8.

40.2 Style 2. Style 2 looped closures shall be closed by bringing the cleats at the closing edge together and inserting the narrow loop through the wide loop and bending it horizontally against the side of the crate. Style 2 loop closures shall be closed with a Sallee Closer as shown on figures 7 and 9. If a tool other than a Sallee Closer, i.e., hammer, is used it should be determined that the closure is similar in all respects regarding tightness of wire, fold over of loop and radius of bends of the wire. That portion of the wire loop which is bent horizontally shall be essentially parallel to the side of the crate and the end of the narrow loop shall be not more than 1/4 inch away from the side of the crate.

MIL-C-11133D

## 50. INSPECTION PROCEDURES

50.1 Inspection. Crates shall be inspected to determine compliance with requirements of this appendix. Sampling shall be conducted in accordance with the provisions of MIL-STD-105.

50.1.1 Examination of assembly and closure. Classification of defects shall be as specified in table X. The sample unit shall be one completely assembled and closed crate. The sample size shall be as indicated by inspection level S-4. The acceptable quality levels, expressed as defects per hundred units, shall be 4.0 for major defects and 10.0 for total defects. The application of the inspection level and the acceptable quality level shall be in accordance with MIL-STD-105.

TABLE XIV. Classification of defects for assembly and closure

Examine	Defect	Classification	
		Major	Minor
Assembly type II, class 2	End boards not fastened to inside of side cleats with nails or staples	X	
	Nails or staples for fastening end boards to side cleats less than diameter or gage specified		X
	Length of fasteners less than thickness of end-boards plus 3/4 thickness of the cleats		X
	Point of fasteners protrudes from cleat. Average spacing of fasteners more than 2-1/2 inch		X
Type III, styles 1, 2 and 3	Bottom cleat of front and back sections not fastened to skid of base as specified	X	
	Faceboard and cleat at center of each side section, not fastened to adjacent cleat or center skid as specified	X	
	Top not fastened as specified	X	
	Size and type of nail not as specified	X	
Closure types 1, 2 and 3, all styles	Not closed	X	
	Not closed as specified		X
	Insecure closure	X	
Condition of crates	Broken or fractured wooden component	X	
	Broken wire	X	

MIL-C-11133D

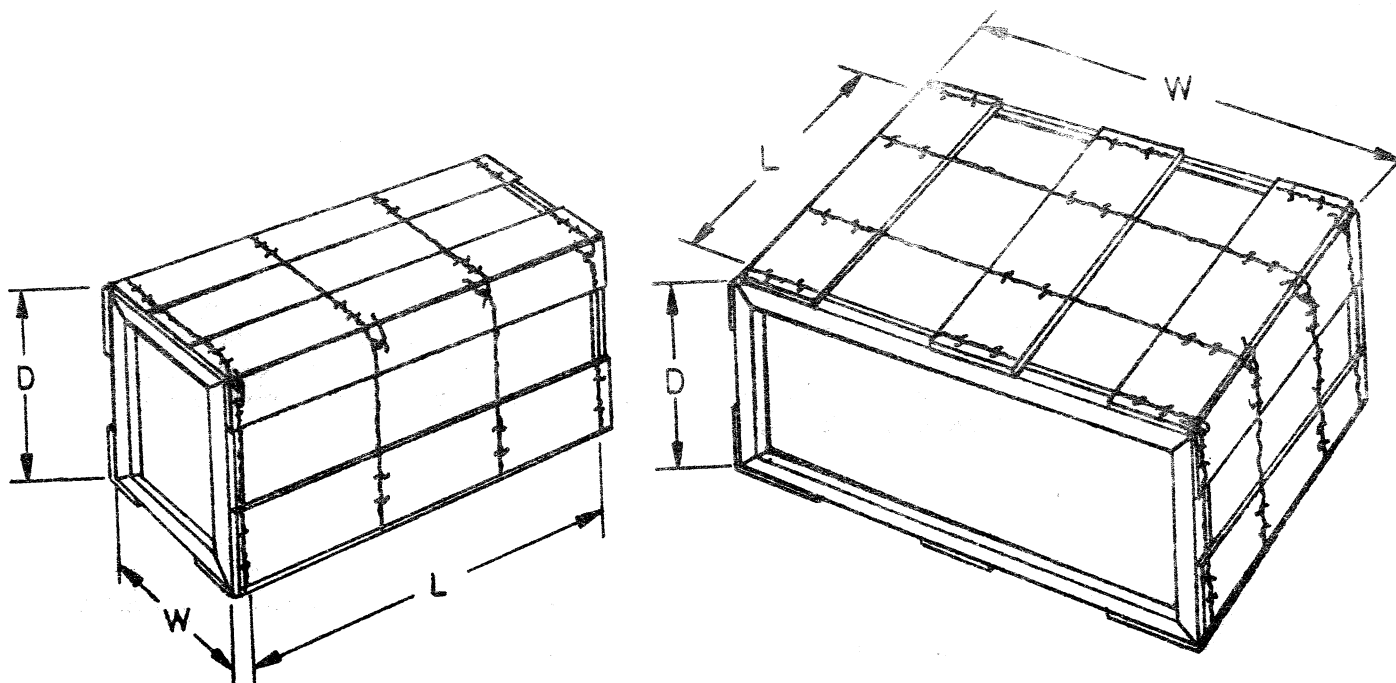

Overwrap - no ends - see 6.1.2  
 Maximum weight of contents 200\* pounds for type I load only.

## Notes:

1. Add 1/4 inch to dimensions required to clear intended load. Inside length of overpack is distance between cleats.
2. Cleats shall be 13/16 wide by 3/4 inch thick for length of cleat not exceeding 30 inches, and contents not exceeding 125 pounds.  
 \*When cleat required is over 30 inches long or weight of contents exceeds 125 pounds, cleats shall be 1-1/8 x 1-1/8 inch. No cleat shall exceed 60 inches long. No intermediate cleats are required.
3. Faceboard thickness shall be as specified in table IV.
4. Minimum faceboard width shall be 3-3/8 inch. Maximum space between faceboards shall be 12 inches, but in no case shall the total faceboard coverage be less than 50 per cent on each face.
5. Binding wires - for requirements see tables V and VI.
6. Staples - for requirements see table VII.
7. No ends are required.

*FIGURE I. TYPE I; OVERWRAP, NO ENDS*

MIL-C-11133D

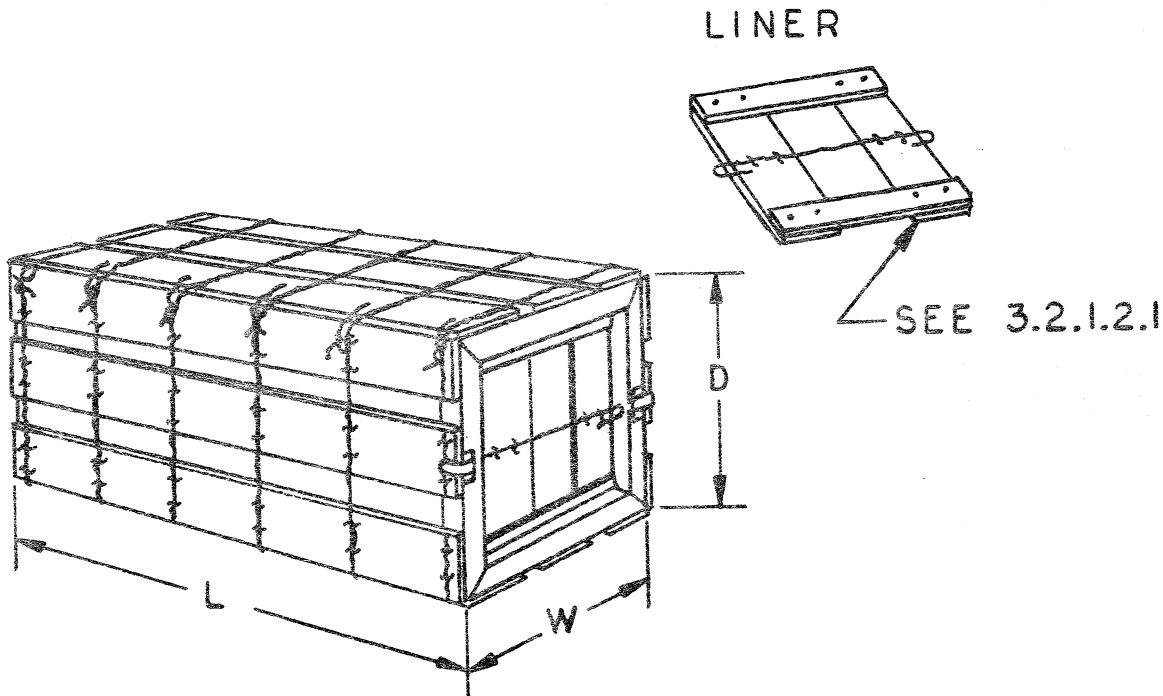

Conventional crate - with wired ends.

Maximum weight of contents 200 pounds. For type I or type II loads only, maximum width or depth shall not exceed 30 inches.

Notes:

1. For inside dimensions add 1/4 inch to dimensions required to clear intended load. Inside length shall be the clear distance between the ends when in the assembled position.
2. Edge cleats shall be 13/16 wide by 3/4 inch thick for length of cleat not exceeding 20 inches. When cleat length required is over 20 inches, cleats shall be 1-1/8 x 1-1/8 inch. See tables II and III for intermediate cleat requirements.
3. Faceboard thickness shall be as required in table IV.
4. Minimum faceboard width shall be 3-3/8 inch. Space between faceboards shall not exceed 12 inches, but in no case shall the total faceboard coverage be less than 50 per cent on each face.
5. Binding wires - for requirements see tables V and VI.
6. Staples - for requirements see tables VII.
7. End construction shall conform to figure 2A except that when specified liners and wires may be on the inside of the crate.

FIGURE 2. TYPE II, CLASS I, CONVENTIONAL CRATE, WIRED ENDS.

MIL-C-11133D

TYPE II, CLASS 1

TYPE II, CLASS 2

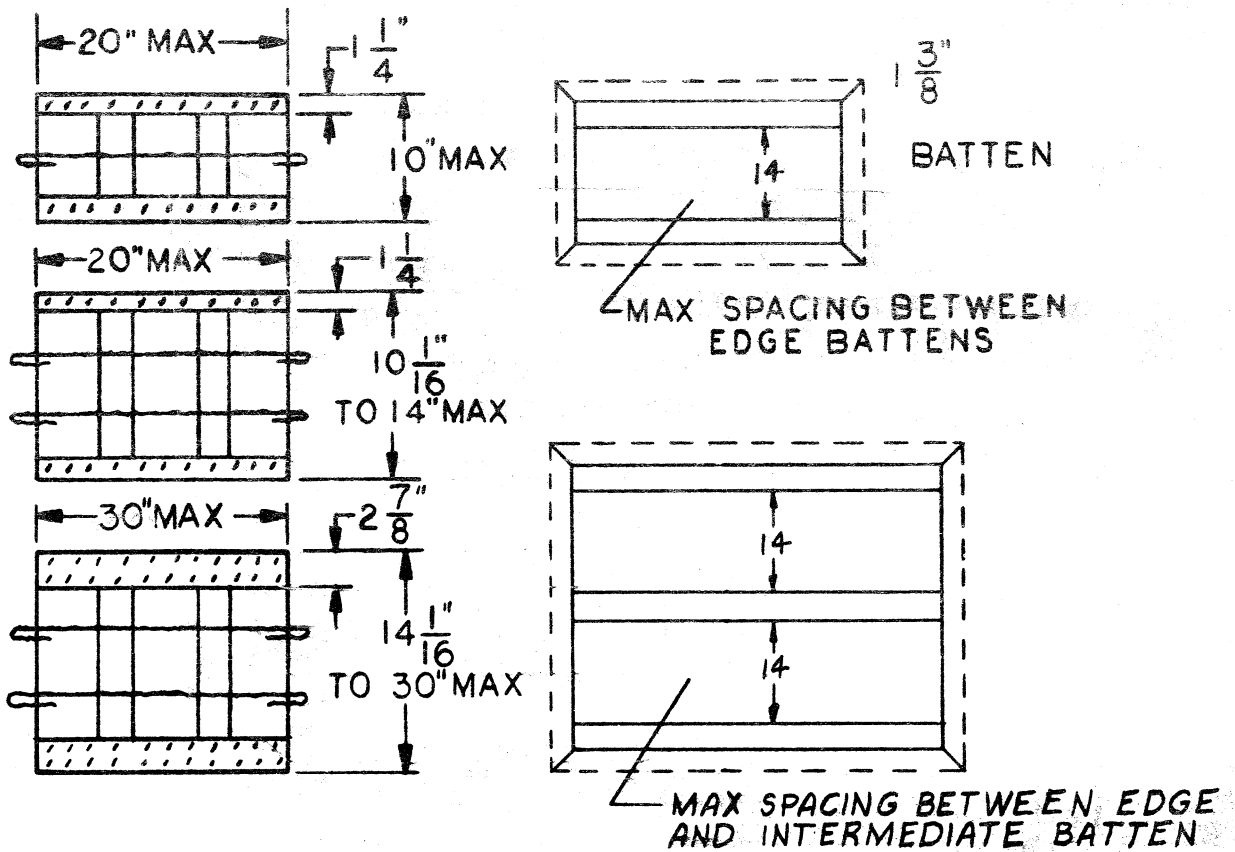

1. Ends - Type II, class 1 - width of liners, number of rows of staples and number of wires shall be as shown. Gage of wire shall be the same as required for the wirebound blank. See table VII for staple requirements.
2. Ends - Type II, class 2 - the minimum size of battens shall be 1-3/8 inches by 3/4 inch.

FIGURE 2A. TYPE II CRATES; END CONSTRUCTION REQUIREMENTS



MIL-C-11133D

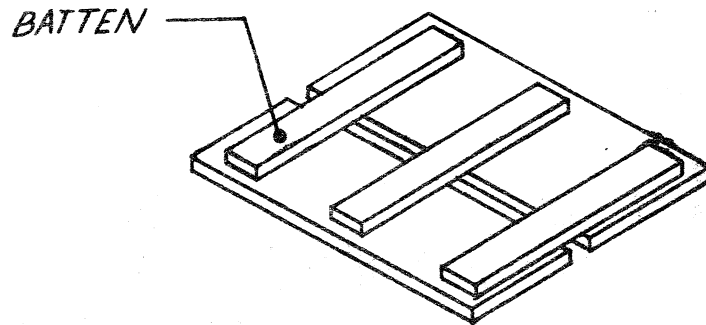

SQUARE END SHOWN

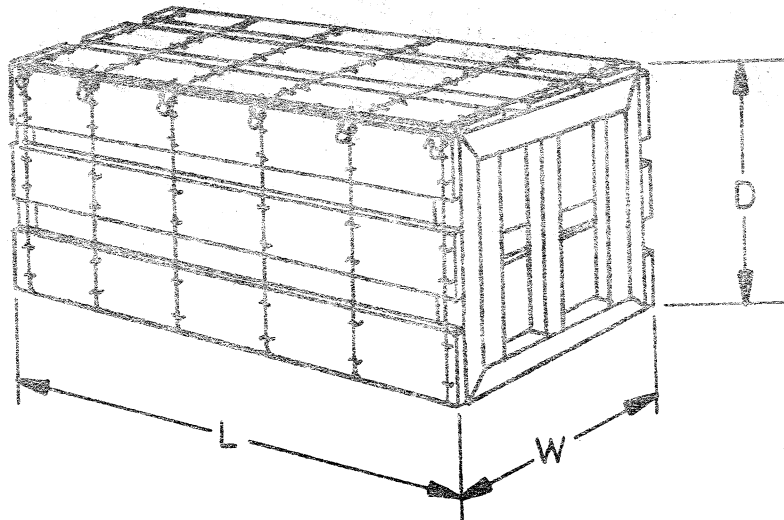
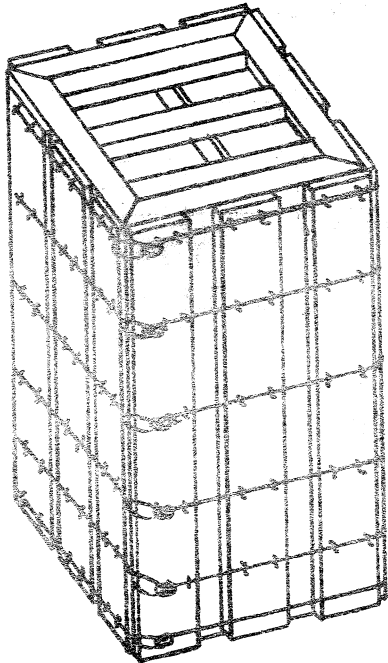

Conventional crate - with batten ends

Maximum weight of contents 200 pounds for type I or II loads only.

## Notes:

1. For inside dimensions add 1/4 inch to dimensions required to clear intended load. Inside length shall be the clear distance between ends when ends are in assembled position.
2. Cleats shall be 13/16 wide by 3/4 inch thick. See tables II and III for intermediate cleat requirements.
3. Faceboard thickness shall be as specified in table IV.
4. Minimum faceboard width shall be 3-3/8 inch. Space between faceboard shall not exceed 12 inches, but in no case shall the total faceboard coverage be less than 50 per cent on each face.
5. Binding wires - for requirements see tables V and VI.
6. Staples - for requirements see table VII.
7. End construction shall conform to figure 2A.

FIGURE 3. TYPE II, CLASS 2; CONVENTIONAL CRATE,  
BATTEN ENDS

MIL-C-11133D

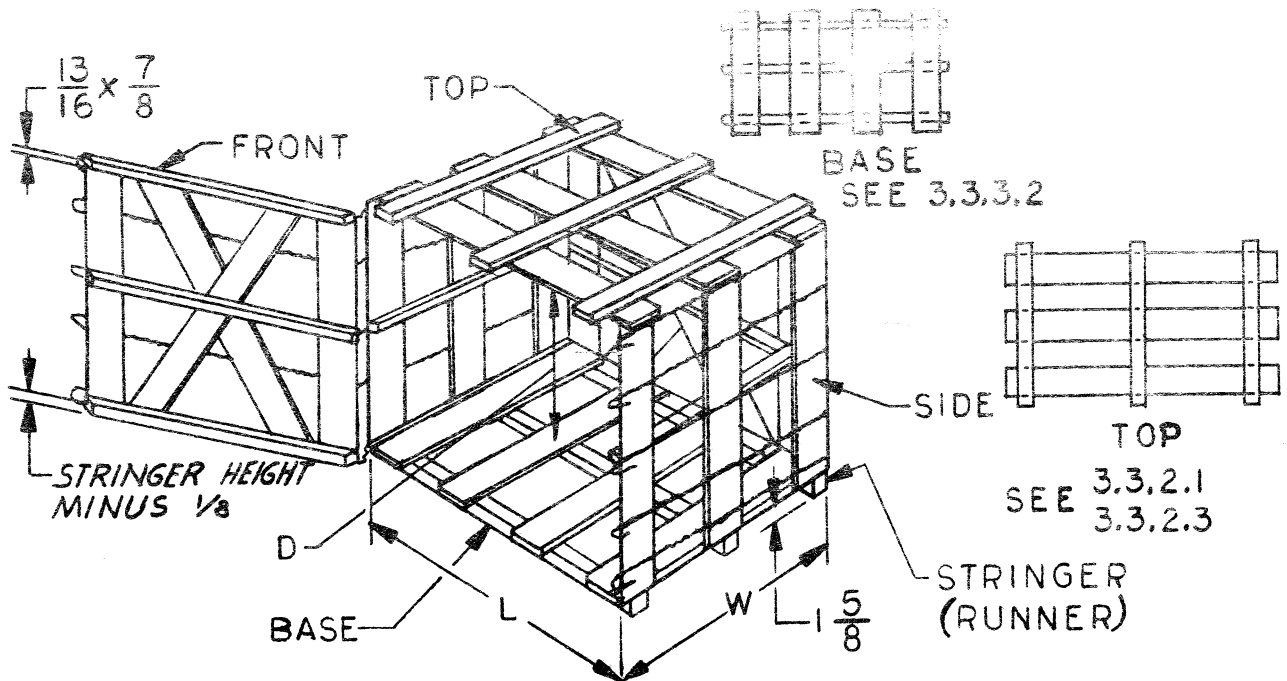

## Notes:

1. For inside dimensions add adequate clearance, as determined by the user, to dimensions required to clear the intended loads. Inside length is the clear inside dimension parallel to the stringers (runners) of the base measured between intermediate cleats if any. Width is the clear inside dimension at 90 degrees to the stringers measured between intermediate cleats, if any. Depth (height) is the vertical dimension required from the top of the base deckboard to the under side of the top. Where no intermediate cleats are required, inside dimensions are the distances between faceboards when crate is in assembled position.
2. Edge cleats shall be  $\frac{13}{16}$  wide by  $\frac{3}{4}$  inch thick, except the front and back bottom cleat, which shall be  $\frac{1}{8}$  inch less than the stringer thickness by  $\frac{3}{4}$  inch.  
See tables II and III for intermediate cleat requirements.
3. Faceboard thickness shall be as specified in table IV.
4. Minimum faceboard width shall be  $3\text{-}\frac{3}{8}$  inch. When diagonals cannot be used because the minimum angle between faceboard and diagonal is less than  $14^\circ$ , space between faceboards shall not exceed 12 inches, but in no case shall the total faceboard coverage be less than  $5^\circ$  per cent of each face.
5. Binding wires - for requirements see tables V and VI.
6. Staples - for requirements see table VII.
7. Base construction - see tables VIII and IX for requirements.

FIGURE 4. TYPE III, CLASS I, UPRIGHT CRATE, INTERLOCKING.

MIL-C-11133D

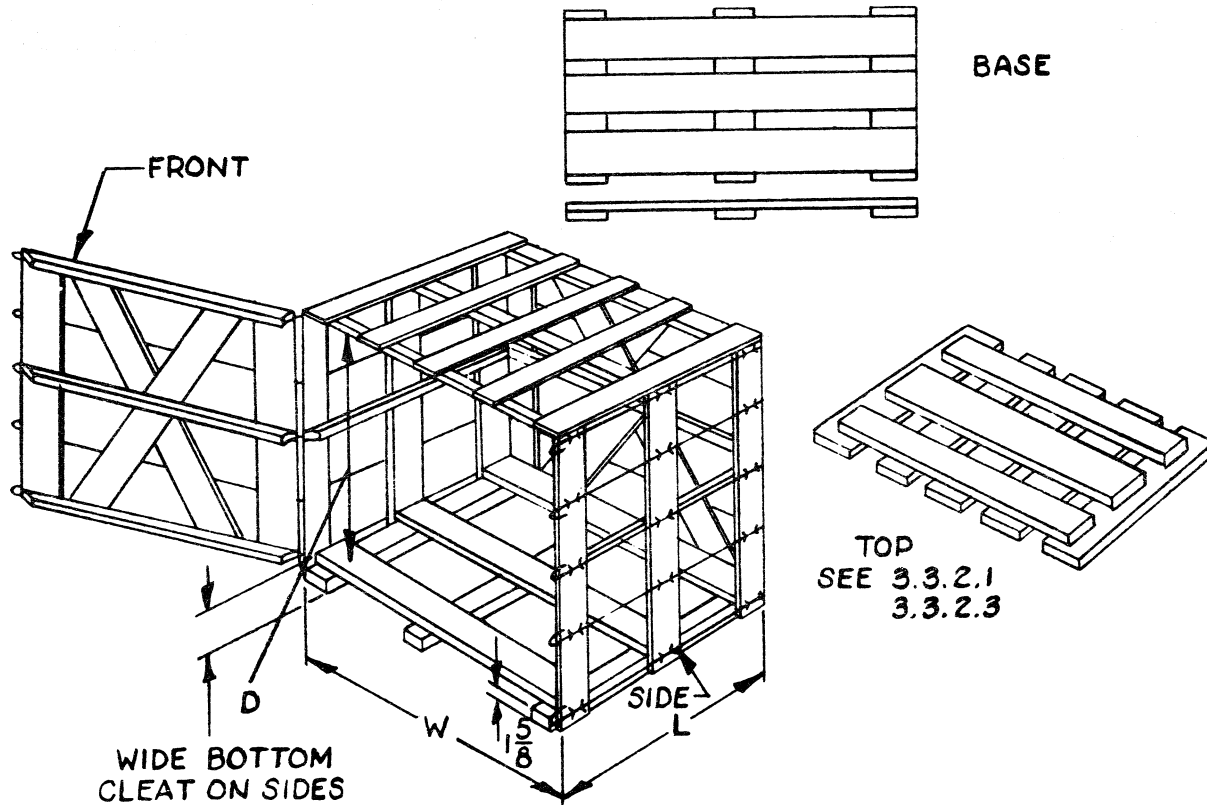

## Notes:

1. For inside dimensions add adequate clearance, as determined by the user, to dimensions required to clear intended load. Inside length is the clear inside dimensions parallel to the stringers (runners) of the base measured between intermediate cleats if any. Width is the clear dimension at 90 degrees to the stringers measured between intermediate cleats if any. Depth (height) is the vertical dimension measured from the top of the base deckboard to the under side of the top. When no intermediate cleats are required, inside length and width are the inside distances between faceboards. Depth is the same as above.
2. Edge cleats shall be  $13/16$  wide by  $3/4$  inch thick, except the wide bottom side cleats as shown above. The width of the bottom side cleats shall be equal to the combined thickness of the stringers (runners) and base deckboards required minus  $1/8$  inch. See tables II and III for intermediate cleat requirements.
3. Faceboard thickness shall be as specified in table IV.
4. Minimum faceboard width shall be  $3-3/8$  inch. When diagonals cannot be used because the minimum angle between faceboard and diagonal is less than  $14^\circ$ , space between faceboards shall not exceed 12 inches, but in no case shall the total faceboard coverage be less than 50 per cent of each face.
5. Binding wires - for requirements see tables V and VI.
6. Staples - for requirements see table VII.
7. Base construction - see tables VIII and IX.

FIGURE 5. TYPE III, CLASS 2; UPRIGHT CRATE,  
FLUSH BASE

MIL-C-11133D

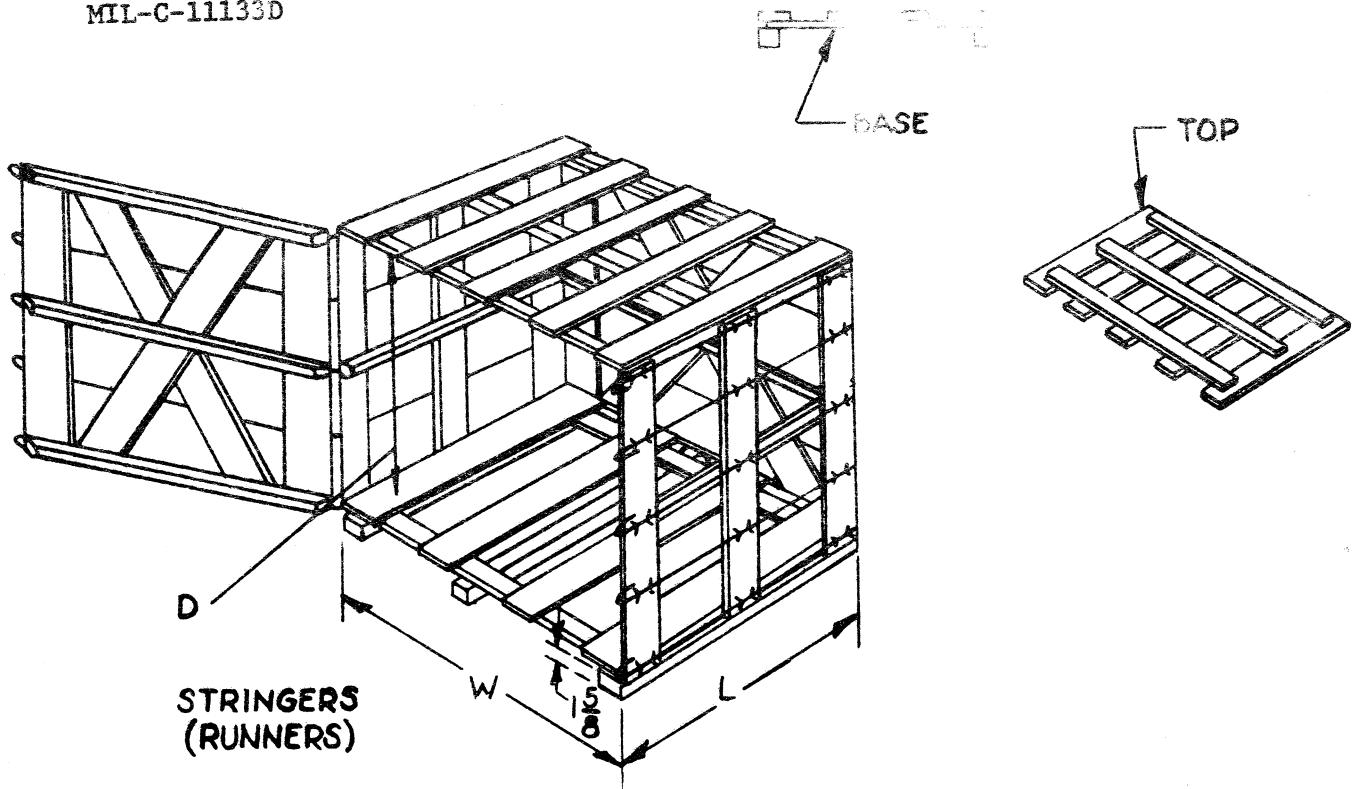

## Notes:

1. For inside dimensions add adequate clearance, as determined by the user, to dimensions required to clear intended load. Inside length is the clear inside dimension parallel to the stringers (runners) of the base measured between intermediate cleats if any. Width is the clear inside dimension at 90 degrees to the stringer measured between intermediate cleats if any. Depth (height) is the vertical dimension measured from the top of the base deckboard to the under side of the top. When no intermediate cleats are required, inside length and width are the distance between faceboards. Depth is the same as above.
2. Edge cleats shall be  $13/16$  wide by  $3/4$  inch thick.
3. Minimum faceboard width shall be  $3-3/8$  inch. When diagonals cannot be used because the minimum angle between faceboard and diagonal is less than  $14^\circ$ , space between faceboards shall not exceed 12 inches, but in no case shall the total faceboard coverage be less than  $5^\circ$  per cent of each face.
4. Binding wires - for requirements see tables V and VI.
5. Staples - for requirements see table VII.
6. Base Construction - see tables VIII and IX.

FIGURE 6. TYPE III, CLASS 3; UPRIGHT CRATE, CHANNEL BASE

MIL-C-11133D

STYLE I TWISTED WIRE CLOSURE

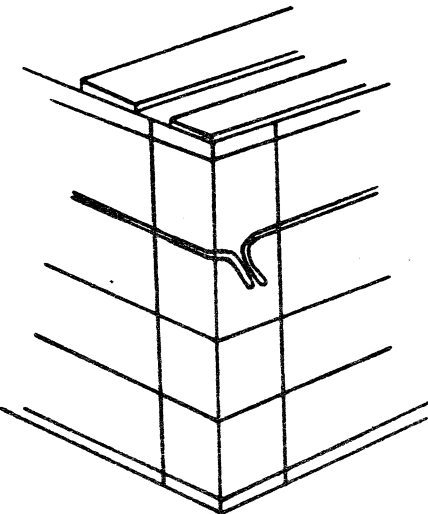
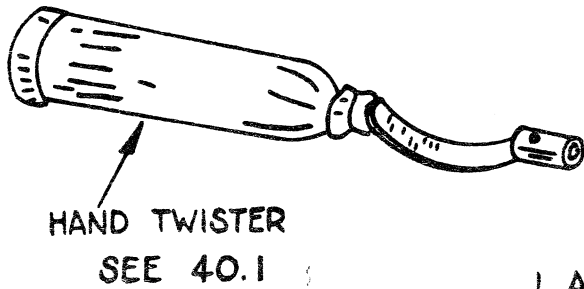

1. AFTER THE CRATE IS PREPARED FOR CLOSING, THE WIRES ARE BENT AT RIGHT ANGLES TO THE BOX APPROXIMATELY 5/8" FROM THE CLOSING EDGE.

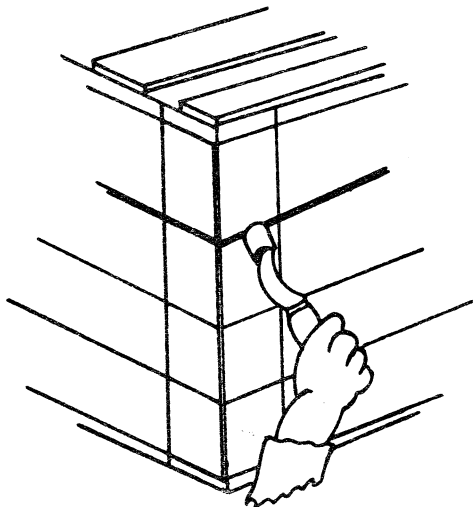

2. THE END OF THE BIT IS PUSHED OVER THE WIRES AGAINST THE CRATE THEN THE HAND TWISTER IS ROTATED UNTIL THE WIRES ARE CUT OFF

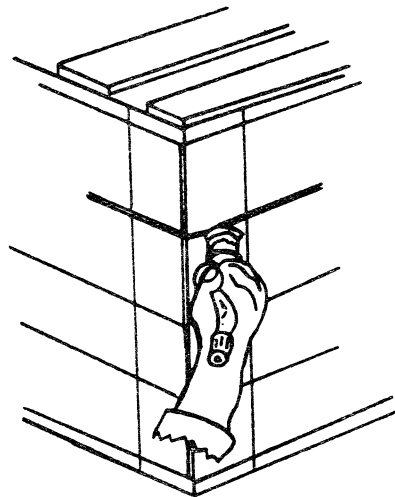

3. AFTER ALL OF THE TWISTS ARE COMPLETED THEY ARE KNOCKED AGAINST THE CRATE PARALLEL TO THE BINDING WIRE - WITH THE BUTT END OF THE TOOL.

CRANK TWISTER AND POWER TWISTER (ELECTRIC OR PNEUMATIC) ARE ALSO AVAILABLE FROM ANY WIRESOUND CRATE SUPPLIER.

FIGURE 7. CLOSING STYLE I CRATE, TWISTED WIRE CLOSURE



MIL-C-11133D

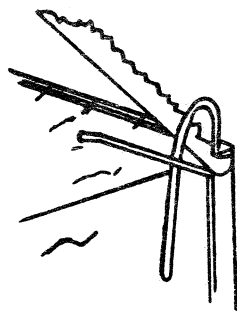

SALLEE CLOSER  
SEE 40.2

1. INSERT SALLEE CLOSER THROUGH NARROW LOOP AND CATCH WIDE LOOP IN NOTCH ON END OF TOOL.

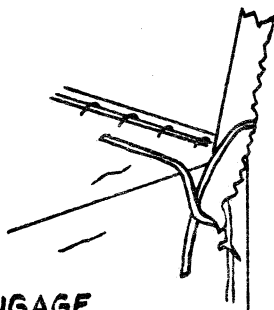

2 PUSH WIDE LOOP AGAINST SURFACE OF CRATE FACE, ENGAGE NARROW LOOP IN TEETH OF TOOL AND START SWING.

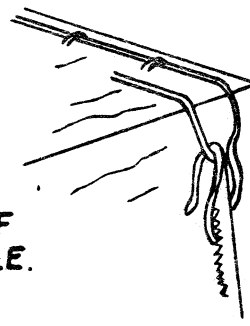

3 COMPLETE CLOSING BY SWINGING HANDLE OF SALLEE CLOSER AROUND AS FAR AS POSSIBLE.

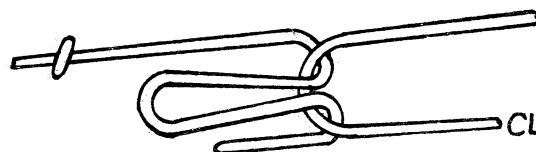

CLINCHED IN WOOD

STYLE 2 LOOPED WIRE CLOSURE

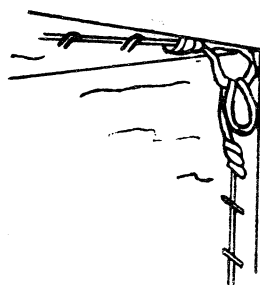

TWISTED LOOP CLOSURE.  
CLOSED SAME AS ABOVE.

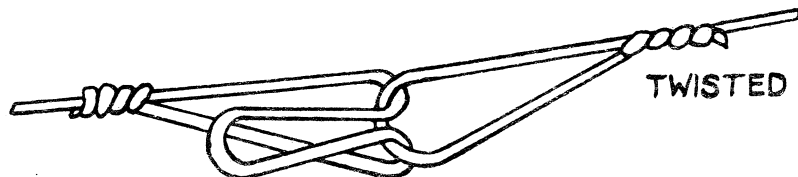

TWISTED

STYLE 2A TWISTED WIRE LOOP CLOSURE

STYLE 2 OR STYLE 2A LOOPS SHALL BE AT MANUFACTURER'S OPTION

FIGURE 8. CLOSING STYLE 2 CRATE; LOOPED WIRE CLOSURE

MIL-C-11133D

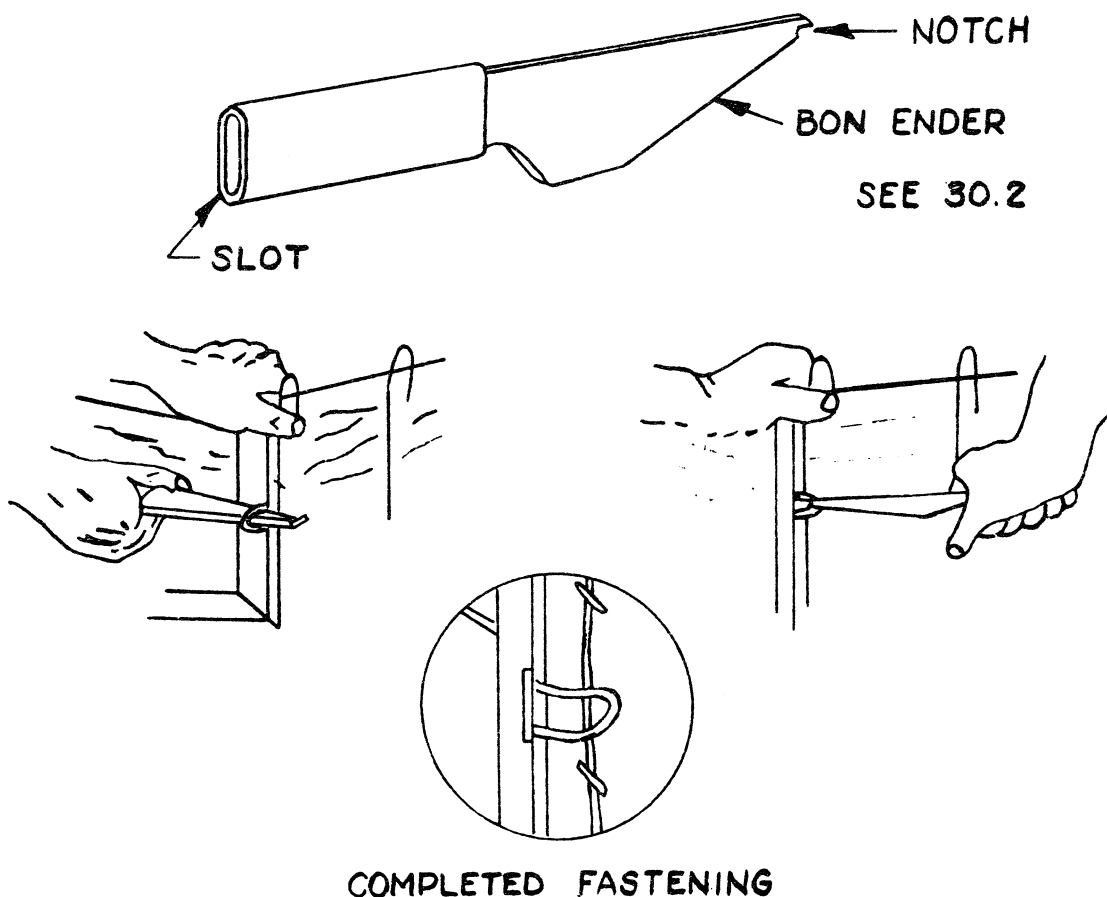

1. Slide handle of Bon Ender over loop of end and bend loops at right angle to end boards.
2. Push loops of end through notches in side cleats of blank.
3. To fasten ends, insert nose of Bon Ender in loop of end, pulling tightly against cleat by pressing on handle. Holding tension, swing Bon Ender around edge of crate until it touches binding wire. Then slide Bon Ender back through loop until notch in end of tool engages binding wire. Complete motion until end of loop touches side of crate.

Bon Enders are available from crate supplier.

*FIGURE 9. SETTING UP TYPE II, CLASS I CRATES*

## STANDARDIZATION DOCUMENT IMPROVEMENT PROPOSAL

OMB Approval  
No. 22-R255

**INSTRUCTIONS:** The purpose of this form is to solicit beneficial comments which will help achieve procurement of suitable products at reasonable cost and minimum delay, or will otherwise enhance use of the document. DoD contractors, government activities, or manufacturers/vendors who are prospective suppliers of the product are invited to submit comments to the government. Fold on lines on reverse side, staple in corner, and send to preparing activity. Comments submitted on this form do not constitute or imply authorization to waive any portion of the referenced document(s) or to amend contractual requirements. Attach any pertinent data which may be of use in improving this document. If there are additional papers, attach to form and place both in an envelope addressed to preparing activity.

## DOCUMENT IDENTIFIER AND TITLE

MIL-C-11133D Crates, Shipping, Wood, Open, Wirebound

## NAME OF ORGANIZATION AND ADDRESS

## CONTRACT NUMBER

## MATERIAL PROCURED UNDER A

 DIRECT GOVERNMENT CONTRACT     SUBCONTRACT

## 1. HAS ANY PART OF THE DOCUMENT CREATED PROBLEMS OR REQUIRED INTERPRETATION IN PROCUREMENT USE?

A. GIVE PARAGRAPH NUMBER AND WORDING.

B. RECOMMENDATIONS FOR CORRECTING THE DEFICIENCIES

## 2. COMMENTS ON ANY DOCUMENT REQUIREMENT CONSIDERED TOO RIGID

## 3. IS THE DOCUMENT RESTRICTIVE?

 YES     NO (If "Yes", in what way?)

## 4. REMARKS

SUBMITTED BY (Printed or typed name and address - Optional)

TELEPHONE NO.

DATE