

MILITARY SPECIFICATION

AMPLIFIERS, RADIOFREQUENCY AND MICROWAVE, SOLID-STATE,
GENERAL SPECIFICATION FOR

This specification is approved for use by all Departments and Agencies of the Department of Defense.

1. SCOPE

1.1 Scope. This specification establishes the general requirements for solid-state RF and microwave amplifiers and the quality assurance requirements which must be met in the acquisition of amplifiers. Detail requirements, specific characteristics of amplifiers and other provisions shall be specified in the applicable specification sheet.

1.2 Military part numbers. The military part number shall consist of the letter "M" followed by the basic number of the specification sheet, an assigned dash (see 3.1), and the letter N or S, where N indicates a nonscreened item and S1 or S2 indicates a screened item. The S2 items shall require more testing than the S1 items (see table III).

	M28875 / 1 - 01	N	or S1	or S2
Military designator and specification sheet no.				
Dash number designated on specification sheet				
Nonscreened				
Screened				

1.2.1 Military designation. The M28875 military designator for amplifiers means a "MIL" specification item produced in full compliance with the specification and the referenced specification sheet. Any item which does not meet all the applicable requirements of this specification and the applicable specification sheet shall not make any representation of being fully compliant with MIL-A-28875. Violation of the requirements of this paragraph may be cause for removal of the manufacturer's product from the Qualified Products List.

2. APPLICABLE DOCUMENTS

2.1 Government specifications and standards. Unless otherwise specified, the following specifications and standards, of the issue listed in that issue of the Department of Defense Index of Specifications and Standards specified in the solicitation, form a part of this specification to the extent specified herein.

SPECIFICATIONS

FEDERAL

- L-P-403 - Plastic Molding Material, Polytetrafluoroethylene (TFE-Fluorocarbon).
- QQ-A-200 - Aluminum Alloy, Bar, Rod, Shapes, Structural Shapes, Tube and Wire, Extruded: General Specification For.
- QQ-A-250 - Aluminum and Aluminum Alloy Plate and Sheet: General Specification For.
- QQ-A-596 - Aluminum Alloy Permanent and Semi-permanent Mold Castings.
- QQ-A-601 - Aluminum-Alloy Sand Castings.

Beneficial comments (recommendations, additions, deletions) and any pertinent data which may be of use in improving this document should be addressed to: Naval Electronic Systems Command, Department of the Navy, ATTN: ELEX 8111, Washington, DC 20363 by using the self-addressed Standardization Document Improvement Proposal (DD Form 1426) appearing at the end of this document or by letter.

MIL-A-28875

- QQ-S-365 - Silver Plating, Electrodeposited, General Requirement For.
- QQ-S-763 - Steel Bars, Wire, Shapes, and Forgings, Corrosion-Resisting.
- QQ-S-781 - Strapping, Steel, and Seals.
- PPP-B-566 - Box, Folding, Paperboard.
- PPP-B-585 - Boxes, Wood, Wirebound.
- PPP-B-601 - Boxes, Wood, Cleated-Plywood.
- PPP-B-621 - Boxes, Wood, Nailed and Lock-Corner.
- PPP-B-636 - Boxes, Shipping, Fiberboard.
- PPP-B-676 - Boxes, Setup.
- PPP-C-1842 - Cushioning Material, Plastic, Open Cell (For Packaging Applications).

MILITARY

- MIL-P-116 - Preservation, Methods of.
- MIL-B-117 - Bags, Sleeves and Tubing - Interior Packaging.
- MIL-P-1144 - Pipe, Stainless Steel (Corrosion-Resistant) Seamless or Welded.
- MIL-C-3643 - Connectors, Coaxial, Radio Frequency, Series HN and Associated Fittings, General Specification For.
- MIL-C-3650 - Connectors, Coaxial, Radiofrequency, Series LC.
- MIL-F-3922 - Flanges, Waveguide, General Purpose, General Specification For.
- MIL-B-5087 - Bonding, Electrical, and Lighting Protection, For Aerospace Systems.
- MIL-C-5541 - Chemical Conversion Coatings on Aluminum and Aluminum Alloys.
- MIL-T-10727 - Tin Plating, Electrodeposited or Hot-Dipped, for Ferrous and Nonferrous Metals.
- MIL-F-14072 - Finishes for Ground Electronic Equipment.
- MIL-W-16878 - Wire, Electrical, Insulated, General Specification For.
- MIL-P-19468 - Plastic Rods Polytetrafluoroethylene, Molded and Extruded.
- MIL-S-19500 - Semiconductor Devices, General Specification For.
- MIL-C-24308 - Connectors, Electric, Rectangular, Miniature Polarized Shell, Rack and Panel, General Specification For.
- MIL-C-26074 - Coatings, Electroless Nickel, Requirements For.
- MIL-C-26637 - Connectors, Coaxial, Radio Frequency, Series LT, General Specification For.
- MIL-C-26482 - Connectors, Electrical (Circular, Miniature, Quick Disconnect, Environment Resisting) Receptacles and Plugs, General Specification For.
- MIL-P-27418 - Plating, Soft Nickel (Electrodeposited, Sulfamate Bath).
- MIL-H-28719 - Header, Hermetically Sealed.
- MIL-M-38510 - Microcircuits, General Specification For.
- MIL-F-39000 - Flanges, Waveguide, Ridge, General Specification For.
- MIL-C-39012 - Connectors, Coaxial, Radio Frequency; General Specification For.
- MIL-G-45204 - Gold Plating, Electrodeposited.
- MIL-I-46058 - Insulating Compound, Electrical (For Coating Printed Circuit Assemblies).
- MIL-P-55110 - Printed-Wiring Boards.
- MIL-T-55155 - Terminals, Feed thru (Insulated) and Terminals, Stud (Insulated and Noninsulated), General Specification For.
- MIL-C-55302 - Connectors, Printed Circuit Subassembly and Accessories.
- MIL-P-81997 - Pouches, Cushioned, Flexible, Electrostatic-Free, Reclosable, Transparent.

MIL-A-28875

STANDARDS

FEDERAL

FED-STD-H28 - Screw-Thread Standards for Federal Services.

MILITARY

MIL-STD-129 - Marking for Shipment and Storage.
 MIL-STD-202 - Test Methods for Electronic and Electrical Component Parts.
 MIL-STD-454 - Standard General Requirements for Electronic Equipment.
 MIL-STD-461 - Electromagnetic Emission and Susceptibility Requirements for the Control of Electromagnetic Interference.
 MIL-STD-462 - Electromagnetic Interference Characteristics, Measurement of.
 MIL-STD-794 - Parts and Equipment, Procedures for Packaging of.
 MIL-STD-883 - Test Methods and Procedures for Microelectronics.
 MIL-STD-889 - Dissimilar Metals.
 MIL-STD-1276 - Leads for Electronic Component Parts.
 MIL-STD-1285 - Marking of Electrical and Electronic Parts.
 MIL-STD-45662 - Calibration Systems Requirements.

(Copies of specifications, standards, handbooks, drawings, and publications required by manufacturers in connection with specific acquisition functions should be obtained from the contracting activity or as directed by the contracting officer.)

See supplement 1 for list of associated specification sheets.

2.2 Other publications. The following documents form a part of this specification to the extent specified herein. The issues of the documents which are indicated as DoD adopted shall be the issue listed in the current DoDISS and the supplement thereto, if applicable.

INSTITUTE OF ELECTRICAL AND ELECTRONICS ENGINEERS (IEEE)

IEEE-STD-287 - Precision Coaxial Connectors.

(Application for copies should be addressed to the Institute of Electrical and Electronics Engineers Headquarters, 345 East 47 Street, New York, NY 10017).

AMERICAN SOCIETY FOR TESTING AND MATERIALS (ASTM)

ASTM-A582 - Free-Machining Stainless and Heat-Resisting Steel Bars, Hot-Rolled or Cold-Finished.

(Application for copies should be addressed to the American Society for Testing and Materials, 1916 Race Street, Philadelphia, Pennsylvania 19103).

(Industry association specifications and standards are generally available for reference from libraries. They are also distributed among technical groups and using Federal agencies.)

2.3 Order of precedence. In the event of a conflict between the text of this specification and the references other than specification sheets cited herein, the text of this specification shall take precedence.

3. REQUIREMENTS

3.1 Specification sheets. The individual amplifier requirements shall be as specified herein and in accordance with the applicable specification sheets. In the event of any conflict between requirements of the specification and the specification sheet, the latter shall govern.

MIL-A-28875

3.1.1 Reference to specification sheet. For the purpose of this specification, when the terms, "as specified", "when specified" or "when applicable" are used without additional reference to a specific location or document, the intended reference shall be to the specification sheet. When the specification sheet does not contain the information, then the requirement is not applicable to that specific part number or specification sheet.

3.2 Qualification. Amplifiers covered by specification sheets furnished under this specification shall be products which are qualified for listing on the applicable qualified products list at the time set for the opening of bids (see 4.5 and 6.3). When there are no products listed or approved for listing on the qualified products list, the qualification requirement is waived and acquiring activities shall invoke first article inspection.

3.3 First article. Amplifiers furnished under this specification which are not listed or approved for listing on qualified products list shall be products that have been tested and passed first article inspection (see 4.6 and 6.4).

3.4 Material. The material shall be as specified herein and in the applicable specification sheets. When a definite material is not specified, a material shall be used which will enable the amplifier to meet the performance requirements of this specification. Acceptance or approval of any constituent material shall not be construed as a guaranty of the acceptance of the finished product.

3.4.1 Aluminum alloys. Aluminum alloy plates and sheets shall conform to QQ-A-200 or QQ-A-250. Aluminum alloy casting shall conform to QQ-A-596, or QQ-A-601.

3.4.2 Corrosion resisting steel. Corrosion resisting steel pipes shall conform to MIL-P-1144. Corrosion resisting forging shall conform to QQ-S-763.

3.4.3 Bonding. Bonding shall conform to class R of MIL-B-5087.

3.4.4 Dissimilar metals. Unless suitably protected against electrolytic corrosion, dissimilar metals as defined in MIL-STD-889 shall not be in intimate contact.

3.4.5 Fungus inert material. Material used in the construction of amplifiers shall be fungus inert in accordance with Requirement 4 of MIL-STD-454

3.4.6 Insulating compounds. Insulating compounds shall conform to MIL-I-46058.

3.4.7 Plastics. Plastics shall conform to L-P-403 or PTFE of MIL-P-19468.

3.4.8 Headers. Headers shall conform to MIL-H-28719.

3.4.9 Microcircuits. Unless otherwise specified, microcircuits utilized within amplifiers shall be in accordance with MIL-M-38510, class B.

3.4.10 Semiconductors. When the frequency permits, semiconductors shall be in accordance with MIL-S-19500, Jan TX or Jan TXV level.

3.4.11 Printed circuit boards. Printed circuit boards shall be in accordance with MIL-P-55110.

3.4.12 External leads. Lead connections for a specific amplifier shall be a chemical composition conforming to MIL-STD-1276 or MIL-STD-202, Method 208 and shall be solderable, unless otherwise specified.

3.4.13 Socket pins. Socket pins for a specific amplifier shall be in accordance with Header Specification MIL-H-28719.

3.4.14 Terminals. Terminals for a specific amplifier shall be in accordance with MIL-T-55155.

MIL-A-28875

3.4.15 Connectors.

3.4.15.1 Radiofrequency (RF) connectors. RF connectors for a specific amplifier shall be in accordance with MIL-C-39012, MIL-C-3643, MIL-C-3650, or MIL-C-26637 as applicable. The gauging for the connection shall conform to the requirements of the applicable specification. Connector type SMA center contacts shall be captivated. When specified, precision connectors shall be in accordance with IEEE-STD-287.

3.4.15.1.1 Connector metal parts. Unless otherwise specified, the connector and the male center contact pins shall be made of corrosion-resisting steel, type 302 or 304 in accordance with QQ-S-763 or type 302 in accordance with ASTM A582.

3.4.15.2 Power connectors. Power connectors for a specific amplifier shall be in accordance with MIL-C-24308 or MIL-C-26482.

3.4.15.3 Printed circuit connectors. Printed circuit connectors for a specific amplifier shall be in accordance with MIL-C-55302.

3.4.16 Flanges. Flanges for a specific amplifier shall be in accordance with MIL-F-3922 or MIL-F-39000.

3.4.17 Connection caps. All connections that are not normally sealed shall be capped with push-on plastic caps to prevent both damage and the entrance of moisture and foreign material during shipment and storage.

3.4.18 Fastening devices. Fasteners and fastening devices shall be in accordance with MIL-STD-454, Requirement 12.

3.4.19 Wiring. All conventional hookup wiring used in a specific amplifier shall be in accordance with MIL-W-16878, unless otherwise specified.

3.4.20 Threaded parts. All screw threads used in the construction of amplifiers shall be in accordance with FED-STD-H28.

3.5 Design and construction. Amplifiers shall be of the design, construction, and physical dimensions specified.

3.5.1 Frequency range. Amplifiers shall be designed to meet the electrical requirements throughout the specified frequency range.

3.5.2 Bandwidth (when specified). Amplifiers shall be designed to meet the electrical requirements within the specified bandwidth.

3.5.3 Pulse mode (when specified). Amplifiers shall be designed to meet the electrical requirements with the specified pulse width, pulse repetition frequency (PRF), and pulse power.

3.5.4 DC input power. Amplifiers shall be designed to operate within the specified limits of DC voltage and current.

3.5.5 RF input power (CW). Amplifiers shall not be damaged by RF input power equalling the specified maximum rating.

3.5.6 Impedance.

3.5.6.1 RF input and output impedance. Unless otherwise specified, the impedance looking into the input and output connections shall be 50 ohms nominal.

3.5.6.2 Video or monitor output impedance (when specified). The video or monitor output impedance shall be as specified.

3.5.7 Mounting. Amplifiers shall meet their specified requirements mounted in any position.

MIL-A-28875

3.5.8 Housing. All metal housing shall be sealed to prevent entry of moisture and leakage of radiated electromagnetic interference (EMI).

3.5.9 Finish. Unless otherwise specified, the finish shall be as specified in 3.5.9.1 through 3.5.9.3.

3.5.9.1 RF and powermating surface. Mating surfaces shall be finished in gold, nickel, silver, or tin conforming to MIL-G-45204, MIL-C-26074, MIL-P-27418, QQ-S-365, MIL-T-10727 or passivated stainless steel. The minimum thickness for gold and nickel plating shall be 10 microinches and 300 microinches, respectively.

3.5.9.2 External surfaces. All external surfaces except RF and power mating surfaces shall be finished in accordance with MIL-F-14072.

3.5.9.3 Aluminum alloys. Aluminum alloys surfaces shall be nickel plated, gold plated or chemically treated in accordance with MIL-C-5541, class 3. When surfaces are chemically treated, the RF and power mating surfaces shall be conductive.

3.5.10 Damage. Unless otherwise specified, amplifiers shall not be damaged by an open or short circuit on the output with any of the following input conditions.

- a. Removal of input signal.
- b. Open or short circuit on the input transmission line.
- c. Within the specified input power variation.

3.5.11 Weight. The weight of the amplifiers shall be as specified.

3.5.12 Temperature range. The operating and nonoperating temperature range shall be specified.

3.5.13 Derating. Part types designed into amplifiers after the date of this specification and processed to this document shall be derated to the following indicated percentage stress levels.

<u>Part type</u>	<u>Power</u>	<u>Voltage</u>	<u>Current</u>
Microcircuits	75%, see note 1/	N/A	N/A
Transistors	see note 2/	75%	75%
Diodes	see note 2/	50%	50%
Resistors	75%	N/A	N/A
Capacitors	N/A	50%	N/A
Inductors	N/A	N/A	60%

NOTES:

- 1/ Maximum operating temperature not to exceed +150°C, unless otherwise specified.
- 2/ Junction or gate temperature not to exceed +125°C, unless otherwise specified.

MIL-A- 28875

3.5.14 Stability (for small signal gain amplifiers). The design goal for stability shall be for an amplifier to be unconditionally stable over any combination of environmental conditions specified and all frequencies over which the amplifier or any internal stage has a gain greater than unity. Unconditional stability is achieved when the following three inequalities are satisfied for all conditions.

$$\frac{1 + |S_{11}S_{22} - S_{12}S_{21}|^2 - |S_{11}|^2 - |S_{22}|^2}{2|S_{12}S_{21}|} > 1$$

$$\frac{1 - |S_{22}|^2}{|S_{12}S_{21}|} > 1$$

$$\frac{1 - |S_{11}|^2}{|S_{12}S_{21}|} > 1$$

Where S represents the scattering parameters.

3.5.15 Pre-seal bake. Hermetic sealed amplifiers shall have a pre-seal bake in an inert atmosphere at the maximum specified storage or operating temperature, whichever is greater, for a minimum of 16 hours. There shall be a direct transfer to the seal chamber with an inert atmosphere that has a monitored moisture content of less than 0.1 percent.

3.5.16 Soldering (internal). Soldering shall be in accordance with MIL-STD-454, Requirement 5.

3.5.17 Workmanship (internal). Workmanship shall be in accordance with MIL-STD-454, Requirement 9.

3.6 Performance.

3.6.1 Screening. All screened amplifiers produced to this specification shall be screened in accordance with table III, with the exception of those amplifiers that are self contained microelectronics or hybrid circuits and meet the requirements of MIL-M-38510.

3.6.2 Burn-in. All amplifiers produced to this specification shall be burned-in in accordance with 4.8.3. After burn-in, the amplifier shall meet the applicable specified electrical requirements.

3.6.3 Supply current. When amplifiers are tested as specified in 4.8.4, the dc supply currents shall be not more than specified.

3.6.4 Gain. When amplifiers are tested as specified in 4.8.5, the gain shall be not less than specified.

3.6.5 Gain flatness. When amplifiers are tested as specified in 4.8.5, the gain flatness value over the frequency range, shall be not more than specified.

3.6.6 Gain control linearity (when applicable). When amplifiers are tested as specified in 4.8.6, the transfer function of the gain vs voltage shall be monotonic and have a slope magnitude as specified.

3.6.7 Isolation (when specified). When amplifiers are tested as specified in 4.8.7, the reverse isolation and when applicable the isolation between different channels shall be not less than specified.

3.6.8 Output power. When amplifiers are tested as specified in 4.8.8, the output power at the 1 dB compression point shall be not less than specified over the frequency and dc voltage ranges.

MIL-A-28375

3.6.9 Saturated output power (when specified). When amplifiers are tested as specified in 4.8.9, the saturated output power shall be not less than specified over the operating frequency range.

3.6.10 Video output. When amplifiers are tested as specified in 4.8.10, the video output shall be as specified.

3.6.11 Voltage standing wave ratio (VSWR). When amplifiers are tested as specified in 4.8.11, the VSWR at the input and output shall be not greater than specified.

3.6.12 Noise figure. When amplifiers are tested as specified in 4.8.12, the noise figure shall be not greater than specified.

3.6.13 Intercept point (see 6.5). When amplifiers are tested as specified in 4.8.13, the intercept point for the second and third order two tone intermodulation products shall be as specified.

3.6.14 Phase linearity (see 6.5) (when specified). When amplifiers are tested as specified in 4.8.14, the phase linearity over the frequency range or bandwidth shall be not greater than specified.

3.6.15 Group delay (see 6.5) (when specified). When the group delay value of an amplifier is determined as specified in 4.8.15, the value shall be within the specified range.

3.6.16 Amplitude modulation to phase modulation conversion (AM/PM) (see 6.5) (when specified). When amplifiers are tested as specified in 4.8.16, the AM/PM conversion shall be not greater than specified.

3.6.16.1 Amplitude modulation (AM). When amplifiers are tested as specified in 4.8.16.1, AM due to power supply ripple shall not exceed the value specified.

3.6.17 Harmonics and spurious (Nonharmonics) (when specified). When amplifiers are tested as specified in 4.8.17, the second and third harmonics amplitude levels and the largest spurious amplitude level shall be not greater than specified.

3.6.17.1 Spurious. When amplifiers are tested as specified in 4.8.17.1, spurious signals shall not exceed the value specified for all output levels below the 1 dB compressed gain power output level.

3.6.17.2 Harmonics. When amplifiers are tested as specified in 4.8.17.2, the sum of all harmonics power shall not exceed the value specified for the rated power output level and the fundamental frequency.

3.6.18 Logarithmic (video) accuracy (when specified). When amplifiers are tested as specified in 4.8.18, the logarithmic accuracy shall be within the specified range.

3.6.19 Logarithmic (video) sensitivity (when specified). When amplifiers are tested as specified in 4.8.18, the logarithmic sensitivity shall be not less than specified.

3.6.20 Output pulse response (see 6.5) (when specified). When amplifiers are tested as specified in 4.8.19, the rise time, fall time, droop, overshoot, and settling time shall be as specified.

3.6.21 Gain vs temperature. When amplifiers are tested as specified in 4.8.20, the gain variation over the operating temperature range shall not exceed the specified value.

3.7 Solderability (as applicable). When amplifiers with solderable connections are tested as specified in 4.8.21, they shall meet the acceptable criteria of method 208 of MIL-STD-202.

MIL-A-28875

3.8 Resistance to soldering heat (as applicable). When amplifiers with solderable connections are tested as specified in 4.8.22, there shall be no damage to the amplifier or to the terminal insulator that will cause electrical failure. Chipping of the terminal insulator shall not be cause for failure, unless the chipping extends to the outer periphery. After the test, the gain of the amplifier shall be not less than specified and the supply current to the amplifier shall not exceed the maximum specified value.

3.9 Resistance to solvents (as applicable). When amplifiers are tested as specified in 4.8.23, the marking shall be legible at a distance of at least six inches with normal room lighting, and there shall be no visual evidence of mechanical damage or deterioration of materials or finishes under 3X magnification.

3.10 Terminal strength/lead integrity (as applicable). When amplifiers are tested as specified in 4.8.24, there shall be no evidence of a broken terminal (lead), elongation greater than 1/2 of the thread pitch, or breakage, loosening, or relative motion between the terminal and the amplifier body when viewed through a magnification of at least 10X. Any of these shall be considered an amplifier failure. After the test, the gain of the amplifier shall be not less than specified and the supply current to the amplifier shall not exceed the maximum specified value.

3.11 Thermal shock. When amplifiers are tested as specified in 4.8.25, there shall be no evidence of physical damage. Upon completion of this test, amplifiers shall meet the gain and supply current requirements.

3.12 Vibration. When amplifiers are tested as specified in 4.8.26, there shall be no evidence of physical damage.

3.13 Shock. When amplifiers are tested as specified in 4.8.27, there shall be no evidence of physical damage. Upon completion of this test, amplifiers shall meet the gain and supply current requirements.

3.14 Acceleration. When amplifiers are tested as specified in 4.8.28, there shall be no evidence of physical damage. Upon completion of this test, amplifiers shall meet the gain and supply current requirements.

3.15 Seal. When amplifiers are tested as specified in 4.8.29, the amount of leakage rate shall not be exceeded. Upon completion of this test, amplifiers shall meet the gain and supply current requirements.

3.16 Barometric pressure. When amplifiers are tested as specified in 4.8.30, there shall be no evidence of physical damage. During this test, amplifiers shall meet the gain and supply current requirements.

3.17 Temperature extreme. When amplifiers are tested as specified in 4.8.31, there shall be no evidence of damage. During this test, amplifiers shall meet the specified requirements for gain flatness, gain compression, output power, noise figure, gain vs temperature, gain control linearity, isolation, saturated output power, video output, phase linearity, group delay, AM/PM conversion, harmonic and spurious, logarithmic sensitivity, and output pulse response.

3.18 Moisture resistance. When amplifiers are tested as specified in 4.8.32, there shall be no evidence of illegible marking, corrosion, flaking, or pitting of the finish when viewed through a magnification of at least 10X. Upon completion of this test, amplifiers shall meet the gain and supply current requirements.

3.19 Salt spray (when specified). When amplifiers are tested as specified in 4.8.33, there shall be no evidence of warping, cracking, peeling or corrosion that has passed through the plating and exposed the base metal, or any lead breakage when viewed through a magnification of at least 10X. Any of these shall be considered an amplifier failure. Upon completion of this test, amplifiers shall meet the gain and supply current requirements.

3.20 Sand and dust (when specified). When amplifiers are tested as specified in 4.8.34, there shall be no evidence of damage or accumulation of sand and dust. Upon completion of this test, amplifiers shall meet the gain and supply current requirements.

MIL-A- 28875

3.21 Explosion (when specified). When amplifiers are tested as specified in 4.8.35, there shall be no ignition of the ambient atmosphere.

3.22 Electromagnetic interference (EMI). When amplifiers are tested as specified in 4.8.36, the specified interference and susceptibility requirements shall not be exceeded.

3.23 Operating life. When amplifiers are tested as specified in 4.8.37, there shall be no evidence of damage. Upon completion of this test, amplifiers shall meet the gain and supply current requirements.

3.24 Marking. Amplifiers shall be marked in accordance with method I of MIL-STD-1285 with the military part number, manufacturers source code or Logo, date code, country of origin, and serialization. Also, each input and output of the amplifier shall be marked as specified. The size of the marking characters shall be such that no magnification is needed to read the marking. The marking shall be placed on the unit using a method that will provide legible and permanent marking for the amplifier. The manufacturer's name or trade mark may also be included in the marking provided such is not expressly forbidden in the contract.

3.24.1 Date code. Amplifiers shall be marked by a unique code to identify the period during which they were manufactured. The first two numbers in the code shall be two digits of the number of the year, and the third and fourth number shall be two digits indicating the calendar week of the year. When the number of the week is a single digit, it shall be preceded by a zero reading from left to right or from top to bottom, the code number shall designate the year and week, in that order. The date code shall not be altered or removed from the amplifier.

3.24.2 Country of origin. The phrase "Made in U.S.A." shall be marked in small characters below or adjacent to the other marking specified, except for amplifiers made in a foreign country the phrase shall be changed accordingly. If there is limited space, the marking may be shortened to "U.S.A." or to the appropriate accepted abbreviation for the country of origin.

3.24.3 Serialization. Each amplifier shall be marked with a unique serial number assigned consecutively within the inspection lot allowing traceability of the amplifier.

3.25 Workmanship. Amplifiers shall be manufactured and processed in a careful and workmanlike manner in accordance with good engineering and production practices. The amplifier shall be free from tool marks, deep scratches and other defects that will affect life, serviceability, or appearance.

4. QUALITY ASSURANCE PROVISIONS

4.1 Responsibility for inspection. Unless otherwise specified in the contract, the contractor is responsible for the performance of all inspection requirements as specified herein. Except as otherwise specified in the contract, the contractor may use his own or any other facilities suitable for the performance of the inspection requirements specified herein, unless disapproved by the Government. The Government reserves the right to perform any of the inspections set forth in the specification where such inspections are deemed necessary to assure supplies and services conform to prescribed requirements.

4.1.1 Test equipment and inspection facilities. Test and measuring equipment and inspection facilities of sufficient accuracy, quality and quantity to permit performance of the required inspection shall be established and maintained by the contractor. The establishment and maintenance of a calibration system to control the accuracy of the measuring and test equipment shall be in accordance with MIL-STD-45662.

4.2 Classification of inspections. The inspections specified herein are classified as follows

- a. Materials inspection (see 4.3).
- b. Qualification inspection (see 4.5).

MIL-A-28875

- c. First article inspection (see 4.6).
- d. Quality conformance inspection (see 4.7).

4.3 Materials inspection. Materials inspection shall consist of certification supported by verifying data that the material listed in table I, used in fabricating the amplifiers, are in accordance with the applicable referenced specification or requirements prior to such fabrication.

4.4 Inspection conditions. Unless otherwise specified, tests shall be performed under the following conditions:

Ambient temperature - 25°C ±5°C
 Altitude - Ambient
 Humidity - 20 to 90 percent relative humidity
 Electrical ground - Adequate RF grounding shall be provided for all electrical testing

4.4.1 Stabilization of inspection conditions. Unless otherwise specified, temperature and altitude stabilization shall have been attained when the temperature of the amplifier does not change more than 3°C, and the altitude remains constant within ±5 percent over a 10-minute period. Stabilization shall be monitored at intervals of 5 minutes during the test period and at more frequent intervals if the temperature change exceeds 1.5°C during any 5-minute interval.

4.4.2 Test method variations. Variations in the specified test methods are allowed provided that it is demonstrated to the preparing activity or their agent that such variations in no way relax the requirements of this specification and that they are approved before testing is performed. For proposed test variations, test method comparative error analysis shall be made available for checking by the preparing activity or their agent.

TABLE I. Materials inspection.

Material	Requirement paragraph	Applicable specification
Aluminum alloy	3.4.1	QQ-A-200, QQ-A-250, QQ-A-596, QQ-A-601
Corrosion resisting steel	3.4.2	MIL-P-1144, QQ-S-763
Bonding	3.4.3	MIL-B-5087
Dissimilar metals	3.4.4	MIL-STD-889
Fungus inert material	3.4.5	MIL-STD-454
Insulating compounds	3.4.6	MIL-I-46058
Plastics	3.4.7	L-P-403, MIL-P-19468
Headers	3.4.8	MIL-H-28719
Packaged microelectronics and hybrid circuits	3.4.9	MIL-M-38510
Semiconductor	3.4.10	MIL-S-19500
Printed circuit boards	3.4.11	MIL-P-55110
External leads	3.4.12	MIL-STD-1276, MIL-STD-202
Socket pins	3.4.13	MIL-H-28719
Terminals	3.4.14	MIL-T-55155
Connectors	3.4.15	MIL-C-39012, MIL-C-3643, MIL-C-3650, MIL-C-26637, QQ-S-763, ASTM A582, MIL-C-24308, MIL-C-26482, MIL-C-55302
Flanges	3.4.16	MIL-F-3922, MIL-F-39000
Fastening devices	3.4.18	MIL-STD-454
Wiring	3.4.19	MIL-W-16878
Threaded parts	3.4.20	FED-STD-H28
Finish	3.5.9	MIL-G-45204, MIL-C-26074, MIL-P-27418, QQ-S-365, MIL-T-10727, MIL-F-14072, MIL-C-5541

MIL-A-28875

4.5 Qualification inspection. Qualification inspection shall be performed at a laboratory acceptable to the Government (see 6.3) on sample units produced with equipment and procedures normally used in production.

4.5.1 Extension of qualification. Existing qualification of an amplifier in a given package style may be extended when it appears in other package styles by performing the additional applicable mechanical and environmental tests. Qualification of an amplifier may also be extended to other amplifiers within the same specification sheet if they are built and inspected in the same manner, and on the same manufacturing line utilizing the same manufacturing technology, and they are additionally submitted to and pass the electrical and environmental requirements of qualification. The various package styles are the waveguide, dual-in-line (DIP), TO, flatpack, coaxial, and header.

4.5.2 Sample size. Three amplifiers of each part number shall be subjected to qualification inspection.

4.5.3 Inspection routine. The sample shall be subjected to the inspection in table II, in the order shown. All units shall be subjected to and pass the applicable inspection of Group I. The sample shall then be divided into three subgroups and subjected to the inspection for their particular subgroup.

4.5.4 Failure. One or more failure shall be cause for refusal to grant qualification approval. A failure shall be anything that does not meet the requirements of the specification.

TABLE II. Qualification inspection.

Inspection	Requirement paragraph	Test method paragraph
<u>Group I (3 sample units)</u>		
Screening (per table III for screened amplifiers)-	3.6.1	4.8.2
External visual and mechanical inspection (for nonscreened amplifiers)- - - - -	3.1,3.4,3.5.9,3.5.11, 3.24,3.25	4.8.1
Burn-in 48 hours (for nonscreened amplifiers)- - -	3.6.2	4.8.3
Electrical characteristics <u>1/</u> :		
Supply current - - - - -	3.6.3	4.8.4
Gain - - - - -	3.6.4	4.8.5
Gain flatness- - - - -	3.6.5	4.8.5
Gain control linearity - - - - -	3.6.6	4.8.6
Isolation- - - - -	3.6.7	4.8.7
Output power or voltage <u>2/</u> - - - - -	3.6.8	4.8.8
Saturated output power <u>2/</u> - - - - -	3.6.9	4.8.9
Video output - - - - -	3.6.10	4.8.10
VSWR (in/out)- - - - -	3.6.11	4.8.11
Noise figure <u>2/</u> - - - - -	3.6.12	4.8.12
Intercept point <u>2/</u> - - - - -	3.6.13	4.8.13
Phase linearity- - - - -	3.6.14	4.8.14
Group delay- - - - -	3.6.15	4.8.15
AM/PM conversion <u>2/</u> - - - - -	3.6.16	4.8.16
Amplitude modulation (AM)- - - - -	3.6.16.1	4.8.16.1
Harmonics and spurious - - - - -	3.6.17	4.8.17
Spurious - - - - -	3.6.17.1	4.8.17.1
Harmonics- - - - -	3.6.17.2	4.8.17.2
Logarithmic accuracy - - - - -	3.6.18	4.8.18
Logarithmic sensitivity- - - - -	3.6.19	4.8.18
Output pulse response <u>2/</u> - - - - -	3.6.20	4.8.19
Gain vs temperature- - - - -	3.6.21	4.8.20

MIL-A-28875

TABLE II. Qualification inspection - Continued.

Inspection	Requirement paragraph	Test method paragraph
<u>Group IIa (1 sample unit)</u> <u>coaxial and waveguide package style amplifiers</u>		
Thermal shock- - - - -	3.11	4.8.25
Vibration- - - - -	3.12	4.8.26
Shock or acceleration- - - - -	3.13, 3.14	4.8.27, 4.8.28
Seal - - - - -	3.15	4.8.29
Moisture resistance- - - - -	3.18	4.8.32
Sand and dust 1/- - - - -	3.20	4.8.34
External visual & mechanical inspection- - - - -	3.1, 3.4, 3.5.9, 3.5.11, 3.24, 3.25	4.8.1
<u>Group IIb (1 sample unit)</u> <u>Flatpack, DIP, TO, and header package styles for</u> <u>large size amplifiers 3/</u>		
Thermal shock- - - - -	3.11	4.8.25
Vibration- - - - -	3.12	4.8.26
Temperature extreme- - - - -	3.17	4.8.31
Moisture resistance- - - - -	3.18	4.8.32
Seal - - - - -	3.15	4.8.29
Shock- - - - -	3.13	4.8.27
Seal - - - - -	3.15	4.8.29
External visual & mechanical inspection- - - - -	3.1, 3.4, 3.5.9, 3.5.11, 3.24, 3.25	4.8.1
<u>Group IIc (1 sample unit)</u> <u>Flatpack, DIP, TO, and header package styles</u> <u>for small size amplifiers 4/</u>		
Thermal shock- - - - -	3.11	5/
Temperature cycling- - - - -	6/	5/
Moisture resistance- - - - -	3.18	5/
Seal - - - - -	3.15	5/
Shock or acceleration- - - - -	3.13, 3.14	5/
Vibration (variable frequency) - - - - -	3.12	5/
Seal - - - - -	3.15	5/
External visual & mechanical inspection- - - - -	3.1, 3.4, 3.5.9, 3.5.11, 3.24, 3.25	4.8.1
<u>Group IIIa (1 sample unit)</u> <u>coaxial and waveguide package style amplifiers</u>		
Solderability- - - - -	3.7	4.8.21
Resistance to soldering heat - - - - -	3.8	4.8.22
Resistance to solvents - - - - -	3.9	4.8.23
Seal - - - - -	3.15	4.8.29
Terminal strength/lead integrity - - - - -	3.10	4.8.24
Barometric pressure- - - - -	3.16	4.8.30
Temperature extreme- - - - -	3.17	4.8.31
Seal - - - - -	3.15	4.8.29
Salt spray - - - - -	3.19	4.8.33
Explosion- - - - -	3.21	4.8.35
Electromagnetic interference - - - - -	3.22	4.8.36
External visual & mechanical inspection- - - - -	3.1, 3.4, 3.5.9, 3.5.11, 3.24, 3.25	4.8.1

MIL-A-28875

TABLE II. Qualification inspection - Continued.

Inspection	Requirement paragraph	Test method paragraph
<u>Group IIIb (1 sample unit)</u> <u>Flatpack, DIP, TO, and header package styles for</u> <u>large size amplifiers</u> 3/		
Terminal strength/leads integrity- - - - -	3.10	4.8.24
Seal - - - - -	3.15	4.8.29
Solderability- - - - -	3.7	4.8.21
Resistance to solder heat- - - - -	3.8	4.8.22
Resistance to solvents - - - - -	3.9	4.8.23
Seal - - - - -	3.15	4.8.29
Temperature extreme- - - - -	3.17	4.8.31
Acceleration or shock- - - - -	3.14, 3.13	4.8.28, 4.8.27
Seal - - - - -	3.15	4.8.29
Salt spray - - - - -	3.19	4.8.33
Seal - - - - -	3.15	4.8.29
Electromagnetic interference - - - - -	3.22	4.8.36
External visual & mechanical inspection- - - -	3.1, 3.4, 3.5.9, 3.5.11, 3.24, 3.25	4.8.1
<u>Group IIIc (1 sample unit)</u> <u>Flatpack, DIP, TO, and header package styles for</u> <u>small size amplifiers</u> 4/		
Resistance to solvents - - - - -	3.9	5/
Solderability- - - - -	3.7	5/
Leads integrity- - - - -	3.10	5/
Seal - - - - -	3.15	5/
Salt spray - - - - -	3.19	5/
Seal - - - - -	3.15	5/
Electromagnetic interference - - - - -	3.22	4.8.36
External visual & mechanical inspection- - - -	3.1, 3.4, 3.5.9, 3.5.11, 3.24, 3.25	4.8.1
<u>Group IVa, b, or c (1 sample unit)</u>		
Operating life - - - - -	3.23	4.8.37

1/ As applicable (see 3.1).

2/ To be tested at 3 frequencies: low, mid and high end of the band specified.

3/ A large size amplifier is defined as an item with a total weight greater than 18 grams.

4/ A small size amplifier is defined as an item with a total weight of 18 grams or less.

5/ The test method shall be in accordance with groups B, C, or D referenced in method 5005 of MIL-STD-883.

6/ At the conclusion of this test, amplifiers shall meet the specified electrical requirements as referenced in paragraph 3.17.

MIL-A-28875

4.5.5 Disposition of qualification sample units. Sample units which have been subjected to qualification testing shall not be delivered on any contract or purchase order. The Government reserves the right to retain the sample units or to require the contractor to furnish the sample units with the qualification inspection report.

4.5.6 Retention of qualification. To retain qualification, the contractor shall forward a report at 24-month intervals to the qualifying activity. The qualifying activity shall establish the initial reporting date. The report shall consist of:

- a. A summary of the results of the tests performed for inspection of product for delivery (group A and where applicable screening), indicating the number of items that have passed and the number that have failed. The results of tests of all reworked items shall be identified and accounted for.
- b. A summary of the results of tests performed for periodic inspection (group B), including the number and mode of failures. The summary shall include results of all periodic inspection tests performed and completed during the 24-month period. If the summary of the test results indicates nonconformance with specification requirements, and corrective action acceptable to the qualifying activity has not been taken, action may be taken to remove the failing product from the qualified products list.

Failure to submit the report within 60 days after the end of each 24-month period may result in loss of qualification for the product. In addition to the periodic submission of inspection data, the contractor shall immediately notify the qualifying activity at any time during the 24-month period that the inspection data indicates failure of the qualified product to meet the requirements of this specification or that the design of the amplifier will be changed.

In the event that no production occurred during the reporting period, a report shall be submitted certifying that the company still has the capabilities and facilities necessary to produce the amplifiers. If during 2 consecutive reporting periods, there has been no production, the manufacturer may be required, at the discretion of the qualifying activity, to submit the products to testing in accordance with the qualification inspection requirements.

4.6 First article inspection. This inspection consists of meeting all the qualification tests of 4.5, 4.5.2, 4.5.3, and table II. The acquiring activity may require the contractor to furnish first article samples of those amplifiers that they propose to supply for government inspection and contractual approval. First article approval is valid only on the contract under which it is granted, unless extended by the Government to other contracts. First article inspection is performed by the contractor after award of contract and prior to production.

4.7 Quality conformance inspection.

4.7.1 General. Quality conformance inspection shall consist of group A inspection, screening (when applicable), and group B inspections. Group B inspection shall be performed under periodic inspection.

4.7.1.1 Inspection lot. An inspection lot shall consist of all amplifiers with the same part number produced under essentially the same conditions, and offered for inspection at one time.

4.7.1.2 Screening. Screening shall consist of the inspections and tests specified in table III, in the order shown. Amplifiers shall pass screening before being subjected to group A inspection.

4.7.1.3 Group A inspections. Group A inspection shall consist of the inspections and tests specified in table IV, in the order shown.

4.7.1.4 Hundred percent inspection. All screened amplifiers shall be subjected to screening and group A inspections. All nonscreened amplifiers shall be subjected to group A inspection. Defective units shall be individually rejected.

MIL-A-28875

TABLE III. Screening.

Inspection	Requirement paragraph	Test method paragraph	Level	
			1	2
Stabilization bake- - - - -	3.6.1	4.8.2.1	X	X
Thermal shock - - - - -	3.6.1	4.8.2.2	X	X
Acceleration or shock - - - - -	3.6.1	4.8.2.3, 4.8.2.7	X	X
Supply current- - - - -	3.6.1	4.8.2.4	X	X
Gain- - - - -	3.6.1	4.8.2.5	X	X
Burn-in: - - - - -	3.6.1	4.8.2.6		
160 hours			X	
240 hours				X
Seal - - - - -	3.6.1	4.8.2.7	X	X
Supply current- - - - -	3.6.1	4.8.2.4	X	X
Gain- - - - -	3.6.1	4.8.2.5	X	X
Visual and mechanical inspection- - - - -	3.1,3.4,3.5.9, 3.5.11, 3.24, 3.25	4.8.1	X	X

4.7.1.5 Rejected items. If an inspection item is rejected, the contractor may rework it to correct the defects and resubmit for reinspection. Such items shall be separate from new-items, and shall be clearly identified as reinspected items.

4.7.1.6 Disposition of units. Units which have passed the group A inspection may be delivered on the contract or purchase order.

4.7.1.7 Test data. Data shall be taken and recorded for all tests performed on an individual item and sent to the acquiring agency. The manner of performing measurements and data sheets shall be included and shipped in the same container as the amplifiers. No classified information shall appear on the data sheet. Copies of data shall be returned by the manufacturers for at least 36 months.

TABLE IV. Group A inspection.

Inspection	Requirement paragraph	Test method paragraph
Visual and mechanical inspection <u>1/-</u>	3.1, 3.4, 3.5.9, 3.5.11, 3.24, 3.25	4.8.1
Burn-in 48 hours <u>1/</u> - - - - -	3.6.2	4.8.3
Electrical characteristics: <u>2/-</u> - -		
Supply current <u>1/</u> - - - - -	3.6.3	4.8.4
Gain <u>1/</u> - - - - -	3.6.4	4.8.5
Gain flatness - - - - -	3.6.5	4.8.5
Gain control linearity - - - - -	3.6.6	4.8.6
Isolation - - - - -	3.6.7	4.8.7
Output power <u>3/</u> - - - - -	3.6.8	4.8.8
Saturated output power <u>3/</u> - - - - -	3.6.9	4.8.9
Video output - - - - -	3.6.10	4.8.10
VSWR (in/out) - - - - -	3.6.11	4.8.11
Noise figure <u>3/</u> - - - - -	3.6.12	4.8.12
Intercept point <u>3/</u> - - - - -	3.6.13	4.8.13
Phase linearity - - - - -	3.6.14	4.8.14

MIL-A-28875

TABLE IV. Group A inspection - Continued.

Inspection	Requirement paragraph	Test method paragraph
Group delay - - - - -	3.6.15	4.8.15
AM/PM conversion 3/ - - - - -	3.6.16	4.8.16
Amplitude modulation (AM)- - - - -	3.6.16.1	4.8.16.1
Harmonics and spurious - - - - -	3.6.17	4.8.17
Spurious - - - - -	3.6.17.1	4.8.17.1
Harmonics- - - - -	3.6.17.2	4.8.17.2
Logarithmic accuracy - - - - -	3.6.18	4.8.18
Logarithmic sensitivity 3/- - - - -	3.6.19	4.8.18
Output pulse response- - - - -	3.6.20	4.8.19
Gain vs temperature- - - - -	3.6.21	4.8.20

1/ These tests are not required for screened amplifiers, as they have been performed under screening.

2/ As applicable (see 3.1).

3/ To be tested at 3 frequencies: low, mid and high end of the band specified.

4.7.2 Periodic inspections. Periodic inspection shall consist of group B inspection. Except where the results of these inspections show noncompliance with the applicable requirements (4.7.2.5), delivery of products which have passed the screening and group A inspections (screened items only) or group A inspection (nonscreened items only) shall not be delayed pending the results of these periodic inspections.

4.7.2.1 Group B inspection. Group B inspection shall consist of the inspections specified in table V, in the order shown. Group B inspection shall be made on sample units selected from inspection lots which have passed the group A inspection.

4.7.2.2 Sampling plan. Three sample units (see 4.5.2) shall be selected every 24 months. The first inspection shall be 24 months after the date of notification of qualification.

4.7.2.3 Failures. If one or more sample units fail to pass group B inspection, the sample shall be considered to have failed.

4.7.2.4 Disposition of sample units. Sample units which have been subjected to group B inspection shall not be delivered on the contract.

4.7.2.5 Noncompliance. If a sample unit fails to pass group B inspection, the manufacturer shall notify the qualifying activity and cognizant inspection activity of such failure and take corrective action on the materials or processes, or both, as warranted, and on all units of product which can be corrected and which are manufactured under essentially the same conditions, with essentially the same materials and processes, and which are considered subject to the same failure. Acceptance and shipment of the product shall be discontinued until corrective action, acceptable to the Government has been taken. After the corrective action has been taken, group B inspection shall be repeated on additional sample units (all inspections, or the inspection which the original sample failed), at the option of the qualifying activity. Group A inspection may be reinstated; however, final acceptance shall be withheld until the group B inspection has shown that corrective action was successful. In the event of failure after inspection, information concerning the failure and corrective action taken shall be furnished to the cognizant inspection activity and the qualifying activity.

MIL-A-28875

TABLE V. Group B inspection.

Inspection	Requirement paragraph	Test method paragraph
<u>Group Ia (1 sample unit)</u> <u>coaxial and waveguide package</u> <u>styles amplifiers</u>		
Thermal shock- - - - -	3.11	4.8.25
Vibration- - - - -	3.12	4.8.26
Shock or acceleration- - - - -	3.13, 3.14	4.8.27, 4.8.28
Seal - - - - -	3.15	4.8.29
Moisture resistance- - - - -	3.18	4.8.32
Sand and dust 1/- - - - -	3.20	4.8.34
External visual & mechanical inspection- - - - -	3.1, 3.4, 3.5.9, 3.5.11, 3.24, 3.25	4.8.1
<u>Group Ib (1 sample unit)</u> <u>flatpack, DIP, TO, and header</u> <u>package styles for large size</u> <u>amplifiers 1/</u>		
Thermal shock- - - - -	3.11	4.8.25
Vibration- - - - -	3.12	4.8.26
Temperature extreme- - - - -	3.17	4.8.31
Moisture resistance- - - - -	3.18	4.8.32
Seal - - - - -	3.15	4.8.29
Shock- - - - -	3.13	4.8.27
Seal - - - - -	3.15	4.8.29
External visual & mechanical inspection - - - - -	3.1, 3.4, 3.5.9, 3.5.11, 3.24, 3.25	4.8.1
<u>Group Ic (1 sample unit)</u> <u>flatpack, DIP, TO, and header</u> <u>package styles for small size</u> <u>amplifiers 2/</u>		
Thermal shock- - - - -	3.11	3/
Temperature cycling- - - - -	4/	
Moisture resistance- - - - -	3.18	3/
Seal - - - - -	3.15	3/
Shock or acceleration- - - - -	3.13, 3.14	3/
Vibration- - - - -	3.12	3/
Seal - - - - -	3.15	3/
External visual & mechanical inspection - - - - -	3.1, 3.4, 3.5.9, 3.5.11, 3.24, 3.25	4.8.1
<u>Group IIa (1 sample unit)</u> <u>coaxial and waveguide package</u> <u>styles amplifiers</u>		
Solderability- - - - -	3.7	4.8.21
Resistance to soldering heat - - -	3.8	4.8.22
Resistance to solvents - - - - -	3.9	4.8.23
Seal - - - - -	3.15	4.8.29
Terminal strength/lead integrity -	3.10	4.8.24
Barometric pressure- - - - -	3.16	4.8.30
Temperature extreme- - - - -	3.17	4.8.31
Seal - - - - -	3.15	4.8.29
Salt spray - - - - -	3.19	4.8.33
Explosion- - - - -	3.21	4.8.35
Electromagnetic interference - - -	3.22	4.8.36
External visual & mechanical inspection - - - - -	3.1, 3.4, 3.5.9, 3.5.11, 3.24, 3.25	4.8.1

MIL-A-28875

TABLE V. Group B Inspection - Continued.

Inspection	Requirement paragraph	Test method paragraph
<u>Group IIb (1 sample unit)</u> <u>flatpack, DIP, TO, and header</u> <u>package styles for large</u> <u>size amplifiers 1/</u>		
Terminal strength/leads integrity-	3.10	4.8.24
Seal - - - - -	3.15	4.8.29
Solderability- - - - -	3.7	4.8.21
Resistance to soldering heat - - -	3.8	4.8.22
Resistance to solvents - - - - -	3.9	4.8.23
Seal - - - - -	3.15	4.8.29
Temperature extreme- - - - -	3.17	4.8.31
Acceleration or shock- - - - -	3.14, 3.13	4.8.28, 4.8.27
Seal - - - - -	3.15	4.8.29
Salt spray - - - - -	3.19	4.8.33
Seal - - - - -	3.15	4.8.29
Electromagnetic interference - - -	3.22	4.8.36
External visual & mechanical inspec- tion - - - - -	3.1, 3.4, 3.5.9, 3.5.11, 3.24, 3.25	4.8.1
<u>Group IIc (1 sample unit)</u> <u>flatpack, DIP, TO, and header</u> <u>package styles for small size</u> <u>amplifiers 2/</u>		
Resistance to solvents - - - - -	3.9	3/
Solderability- - - - -	3.7	3/
Leads integrity- - - - -	3.10	3/
Seal - - - - -	3.15	3/
Salt spray - - - - -	3.19	3/
Seal - - - - -	3.15	3/
Electromagnetic interference - - -	3.22	4.8.36
External visual & mechanical inspec- tion - - - - -	3.1, 3.4, 3.5.9, 3.5.11, 3.24, 3.25	4.8.1
<u>Group IIIa b, or c (1 sample unit)</u>		
Operating life - - - - -	3.23	4.8.37

1/ A large size amplifier is defined as an item with a total weight greater than 18 grams.

2/ A small size amplifier is defined as an item with a total weight of 18 grams or less.

3/ The test method shall be in accordance with group B, C, or D referenced in method 5005 of MIL-STD-883.

4/ At the conclusion of this test, amplifiers shall meet the specified electrical requirements as referenced in paragraph 3.17.

4.7.3 Inspection of packaging. The sampling and inspection of the preservation and interior package marking shall be in accordance with the group A and B quality conformance inspection requirements of MIL-P-116. The sampling and inspection of the packing and marking for shipment and storage shall be in accordance with the quality assurance provisions of the applicable container specification and the marking requirements of MIL-STD-129.

MIL-A-23975

4.8 Method of inspection.

4.8.1 External visual and mechanical inspection. Amplifiers shall be examined to verify that the materials, design, construction, physical dimensions, finish, marking, serialization, workmanship, and weight are in accordance with the applicable requirements (see 3.1, 3.4, 3.5, 3.24 and 3.25).

4.8.2 Screening (see 3.6.1). Amplifiers shall be screened as specified in 4.8.2.1 through 4.8.2.7.

4.8.2.1 Stabilization bake. Nonoperating amplifiers shall be subjected to a stabilization bake temperature at a minimum of 85°C or the maximum specified temperature, whichever one is the largest for a period of 24 hours.

4.8.2.2 Thermal shock. With the connections uncovered, amplifiers shall be tested in accordance with method 107 of MIL-STD-202. The following details and exceptions shall apply:

- a. Mounting - When applicable, amplifiers may be mounted on a heat sink.
- b. Test condition - B, except the temperature extremes shall be -55°C and +95°C. The number of cycles shall be 10 for 1 hour each. The first three cycles shall be run continuously. Unless otherwise specified, after three cycles, the test may be interrupted after the completion of any full cycle, and the amplifiers are allowed to return to room ambient temperature before testing is resumed.

4.8.2.3 Acceleration. Unless otherwise specified, amplifiers shall be tested in accordance with method 212 of MIL-STD-202. The following details shall apply.

- a. Mounting - Normal mounting means.
- b. Test condition - B, except the g shall be 5,000 in the Y₁ and Y₂ directions for double-sided construction and in the Y₁ direction for all others. Should any point of the amplifier nearest the center of the centrifuge experience less than 90 percent of the g level, the amplifier shall be moved outward on a radius of the centrifuge or the speed of rotation shall be increased until not less than 90 percent of the g level is obtained.

4.8.2.4 Supply current. The current supply to the amplifiers shall be measured as specified in 4.8.4.

4.8.2.5 Gain. The gain of the amplifiers shall be measured as specified in 4.8.5.

4.8.2.6 Burn-in. Amplifiers shall be burn-in in accordance with 4.8.3.

4.8.2.7 Seal. Amplifiers shall be tested as specified in 4.8.2.7.1 or 4.8.2.7.2.

4.8.2.7.1 Hermetic sealed amplifiers. Hermetic sealed amplifiers shall be tested in accordance with method 112 of MIL-STD-202. The following details shall apply:

- a. Test condition letter - C for fine leak and E for gross leak.
- b. Procedure - IIIA for fine.
- c. Degree of fine leakage rate sensitivity
 - (1) 10⁻⁶ atm cm³/S for amplifiers whose external volume is greater than 2 cubic inches.
 - (2) 10⁻⁷ atm cm³/S for amplifiers whose external volume is 2 cubic inches or less.

MIL-A-28875

4.8.2.7.2 Nonhermetic sealed amplifiers (O-ring, solder or encapsulated seal). Nonhermetic sealed amplifiers shall be tested in accordance with method 112 of MIL-STD-202. Test condition letter B shall apply.

4.8.3 Burn-in (see 3.6.2). The amplifier shall be placed within a temperature chamber and the dc power supply voltage connected. The maximum dc power supply voltage shall be applied to the amplifier and the chamber temperature shall be raised so that the measured case temperature is equal to the specified burn-in temperature. Where a heat sink is required for proper operation, the stabilized temperature shall be the temperature of the heat sink. When no burn-in temperature is specified, the temperature shall equal the highest specified operating temperature. The amplifier shall remain under these conditions for a period of 48, 160, or 240 hours (see tables III and IV). Electrical measurements before or during burn-in shall be at the discretion of the manufacturer. After the burn-in, the amplifier shall be removed from the chamber and cooldown with the dc power supply voltage applied. The interruption of dc power supply voltage for up to 1 minute for the purpose of moving the amplifier to a cooldown position separate from the chamber shall not be considered removal of dc power supply voltage. The amplifier shall be considered cooled when its case or heat sink temperature is equal to the room temperature plus the temperature rise resulting from the dc power supply voltage. After cooldown and stabilization have been obtained, the amplifier shall be subjected to the subsequent tests in table III and IV.

4.8.4 Supply current (see 3.6.3). The supply current shall be measured using the test setup of figure 1 or 2. With the RF signal applied to the input and the specified dc power supply voltage applied, record the maximum current from the ammeter.

4.8.5 Gain and gain flatness (see 3.6.4 and 3.6.5). The gain and gain flatness shall be measured and determined using the test setup of figure 1 or 2. The characteristics of the optional low pass filter shall be such that it will attenuate all harmonics of the RF signal for at least 30 dB. Set the input power level to the amplifier at a level that will insure linear operation of the amplifier. Set the generator to the CW manual sweep mode and the start/stop limits to the specified lowest and highest frequency values, respectively. Adjust the horizontal sensitivity of the X-Y recorder for 10 inches of travel and using the generator sweep output signal, set the sweep width for the same values. With the network analyzer and the X-Y recorder properly calibrated, draw calibration lines in 1 dB step above and below the specified gain value of the amplifier on the recorder. For the test setup of figure 2, the calibration lines are drawn on the X-Y recorder prior to connecting the amplifier to points A and B. This is done by having points A and B connected together and attenuators 1 and 2 adjusted for zero dB loss. Unless otherwise specified, adjust the gain of the generator and the network analyzer of figure 1 and the attenuator of figure 2 so that the RF input power level to the amplifier shall be 10 dB below the input compression point. Where the input compression point is equal to the output power at the 1 dB gain compression minus the maximum specified gain +1 dB. Bias the amplifier at the specified nominal value, and trigger the sweep and record the gain. For variable gain amplifiers, the control voltages shall be set so the amplifier shall have maximum gain. For those amplifiers that operate over a range of dc input voltage, the gain measurements shall be performed at the lowest and highest values. From the graph, record the minimum gain over the frequency range and record on the data sheet. From the data, determine the maximum and minimum gain between the lowest and highest specified frequency values. The difference between the maximum and minimum gain over the frequency range is the gain flatness. Record the gain flatness values on the data sheet. Note: The losses of any transition used between equipments or amplifier shall be considered and accounted for in determining the gain. Measurement inaccuracy of the gain shall be no greater than ± 0.65 dB.

MIL-A-28875

4.8.6 Gain control linearity (see 3.6.6). The gain control linearity shall be determined at the center frequency with the amplifiers being supplied with nominal voltage and current, and the RF input level being the same as in paragraph 4.8.5.

Procedure. Use the general procedure of paragraph 4.8.5 and the test setup of figure 1 or 2, with the exception that the gain control signal shall be applied to the amplifier and the horizontal input of the X-Y recorder simultaneously. Energize the system, vary the control signal from its lowest to its highest value and record the resulting gain vs. control signal. From the data, determine the maximum and minimum slope values and verify that it is monotonic. Record the maximum and minimum slope values on the data sheet. Repeat this measurement at the required number of CW frequency points across the operating bandwidth.

4.8.7 Isolation (see 3.6.7). The reverse isolation between the output and input RF ports shall be measured across the specified frequency range using the general test procedures of 4.8.5, with the RF input power to the amplifier set at 0 dBm, and the test setup of figure 1 or 2, with the exception that the RF input of the amplifier shall be connected to test point B and the output is connected to test point A. When applicable, all unused RF ports shall be terminated in matched loads. The amplifiers shall be supplied with nominal dc voltage and current and when applicable, the control voltage to the amplifier shall be set for maximum gain. After recording the reverse isolation, determine the maximum value across the frequency range and record it on the data sheet. Isolation between adjacent RF ports shall be measured across the specified frequency range using the general test procedures of 4.8.5 and the test setup of figure 1 or 2. All other RF ports shall be terminated in matched loads. After recording the isolation for each output port determine the minimum value for each output port and record them on the data sheet. The accuracy of measurements for reverse isolation and isolation shall be within 0.65 dB.

4.8.8 Output power (see 3.6.8). The output power of the amplifier shall be measured using the test setup of figure 3. Adjust the output of the amplifier to a level 10 dB below the minimum power output specified for 1 dB compression. Insert a calibrated pad having a value of approximately 10 dB between points A and B. Increase the RF input power to the amplifier by an amount equal to the attenuation of the calibrated pad. The indicated output shall not decrease more than 1 dB below the initially adjusted level. When applicable, the control voltage shall be set for maximum gain. For those amplifiers that operate over a range of dc input voltage, the output power measurements shall be performed at the lowest and highest values. The output power shall be measured at the typical worst case frequency points. The inaccuracy of this measurement shall be no greater than ± 0.65 dB. NOTE: The insertion loss of the low pass filter needs to be considered in determining the output power.

4.8.9 Saturated output power (see 3.6.9). Using the test setup and procedures of 4.8.8, gradually increase the RF input power to the amplifier until the incremental gain falls to zero dB. Record this value of power on the data sheet. Care should be taken during the measurement to insure that the input power does not exceed a level that would cause the amplifier to be damaged.

4.8.10 Video output (see 3.6.10). The video output level shall be measured using the general test setup of figure 4. With the generator operating at the specified frequency and the calibrated attenuator set to cover the input rf power range of the amplifier, energize the amplifier with nominal bias. After the amplifier and equipment have stabilized, establish a reference on the oscilloscope. Decrease the calibrated attenuator in 5 dB increments until the maximum allowable power is applied to the amplifier. Read the input rf power from the power meter and the video output from the oscilloscope at each increment. In determining the input power, the power meter shall be on its lowest possible range for a given amount of power, and the calibration accuracy of the divider and detector needs to be considered. Record the input power and the output video level on the data sheet. When specified, the reading shall be recorded in dB, millivolts/dB (MV/dB), or volts/dB. Measurement inaccuracy shall be not greater than ± 0.75 dB.

MIL-A-28875

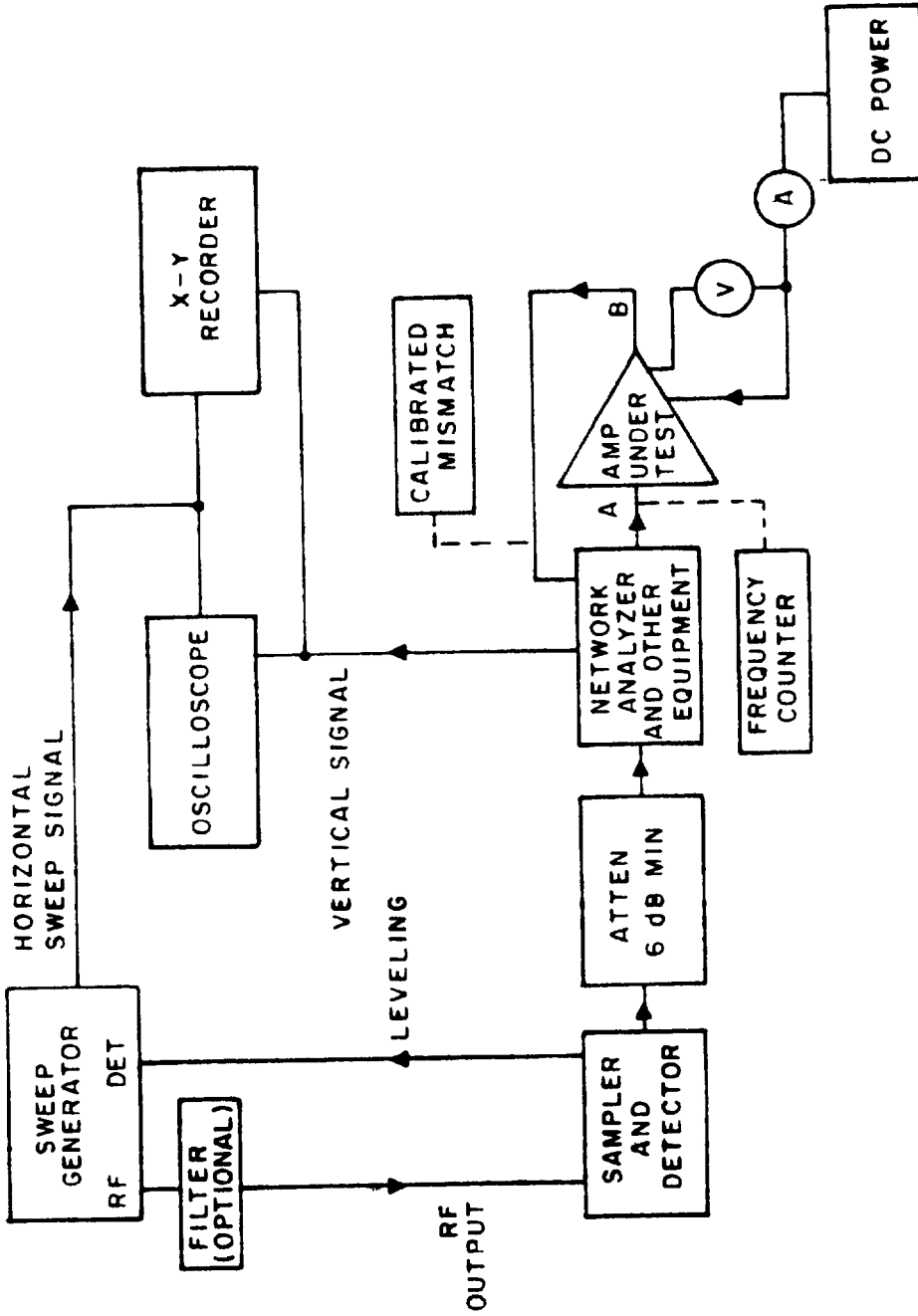

FIGURE 1. Gain, gain flatness and VSMR test setup.

MIL-A-28875

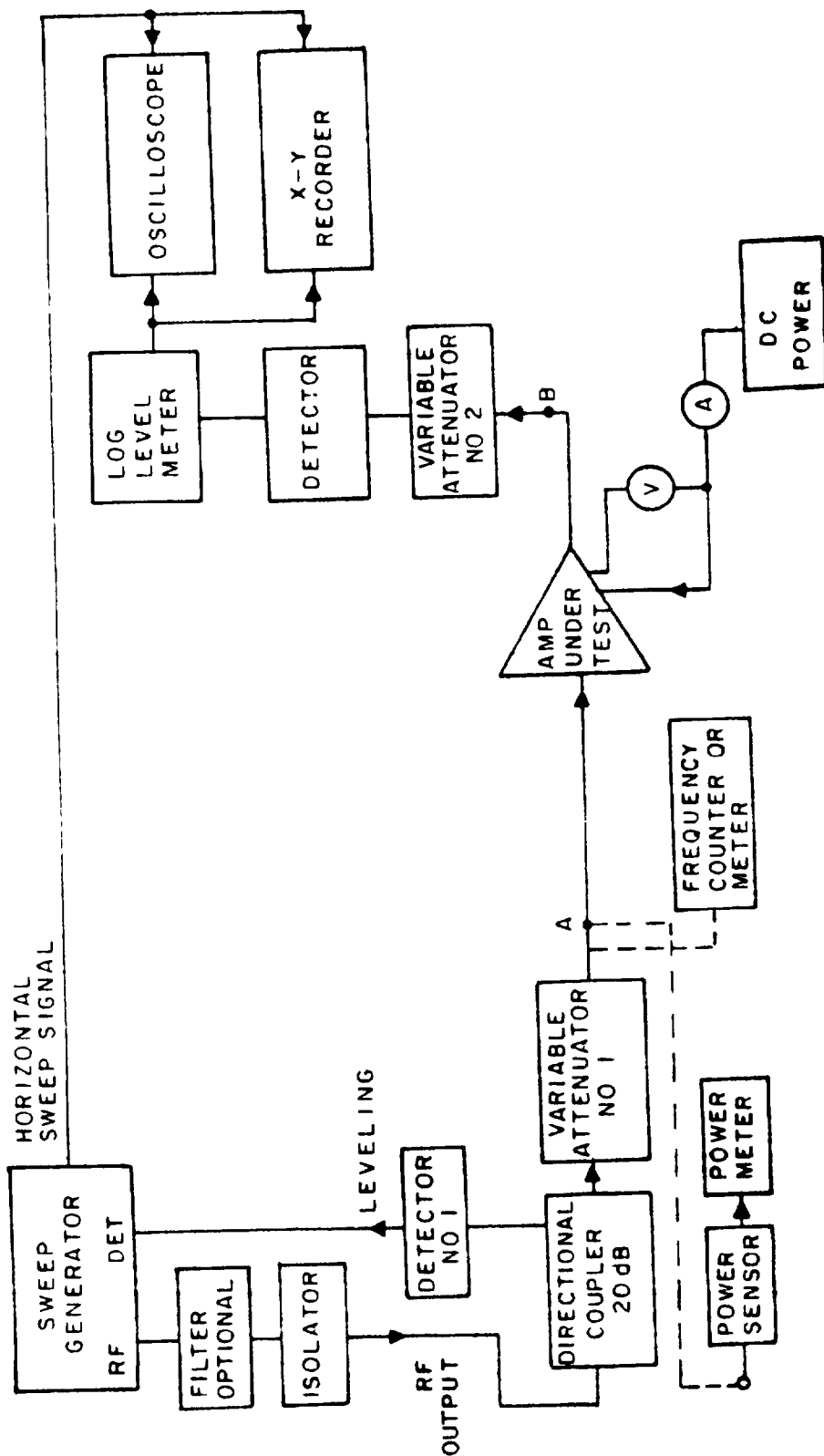

FIGURE 2. Gain and gain flatness test setup.

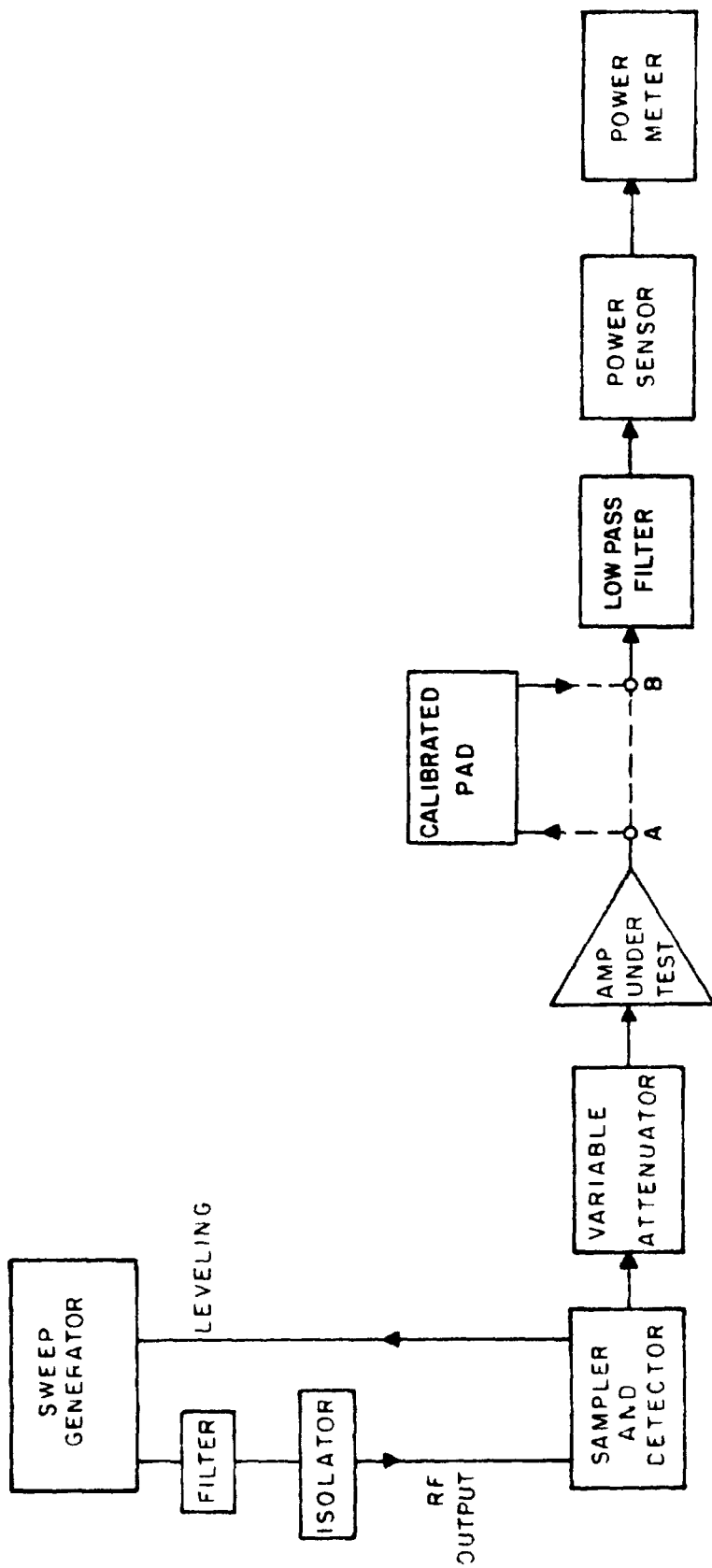

FIGURE 3. Output power test setup.

MIL-A-28875

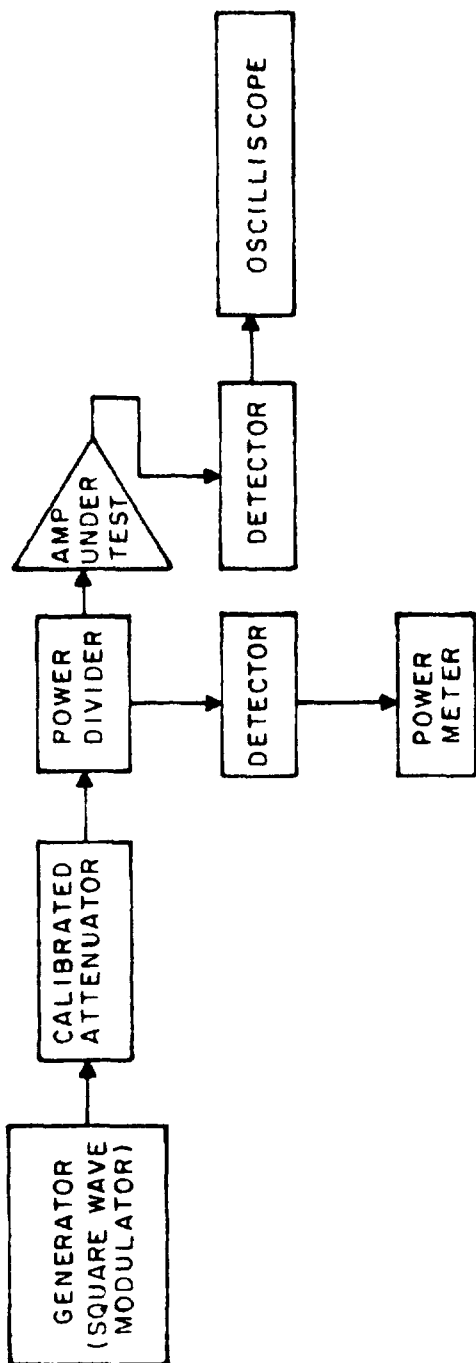

FIGURE 4. Video output test setup.

MIL-A-28875

4.8.11 VSWR (see 3.6.11). The VSWR of the input and output shall be measured or determined across the specified frequency range at low-RF power using the test setup of figure 1 or 5. The RF input power shall be sufficient to prevent false VSWR reading as a result of noise. Unless otherwise specified or needed, the RF power to the amplifier during the test shall be not greater than 10 dB below the compression point. Tuners are permitted to reduce residual VSWR of the measuring system to a level which will assure accurate results before connecting the amplifier under test. Set the generator to the CW manual sweep mode and the start/stop limits to the specified lowest and highest frequency values, respectively. Adjust the horizontal sensitivity of the X-Y recorder for 10 inches of travel and using the generator sweep output signal, set the sweep width for the same lowest and highest frequency values. With the analyzer on, connect the short circuit to point A and establish a reference reading on the analyzer. Remove the short and connect the amplifier with its load to point A. Bias the amplifier at the specified nominal value and when applicable, set the control voltage to the amplifier for maximum gain. Record the VSWR or the equivalent return loss value in increments of 0.1 between VSWR limits of 1.1:1 and 1.9:1, and 0.2 above a VSWR value of 2.0:1. Record the worst case VSWR from the X-Y recorder or calculated value and the bias voltage and current on the data sheet. The overall accuracy of the VSWR measurement shall be such that the absolute VSWR = measured VSWR $\pm k$ (maximum specified VSWR-1). Where $k = 0.1$ for frequencies at or below 12 GHz and $k = 0.2$ for frequencies above 12 GHz. For variable gain amplifier repeat the above procedures with the control voltage set for minimum gain. Reverse the amplifier and repeat the above procedures for the output port.

4.8.12 Noise figure (see 3.6.12). The noise figure shall be measured as specified in 4.8.12.1 or 4.8.12.2.

4.8.12.1 Low noise figure (3 dB or less). The low noise figure shall be measured over the specified frequency range using the test setup of figure 6. With the amplifier properly biased, and the case or heat sink temperature at approximately room ambient, and the test setup calibrated, measure the noise figure at the typical worst case frequency in the specified frequency range. Record the noise figure from the automatic noise figure indicator, dc supply voltage and current and the case or heat sink temperature on the data sheet for each frequency. For qualification or first article, repeat the above procedure with the amplifier stabilized at the highest specified operating temperature range. When measuring the noise figure of a variable gain amplifier, the gain shall be set for maximum. Measurement inaccuracy shall be not greater than ± 0.35 dB.

4.8.12.2 Higher noise figure (greater than 3 dB). The noise figure shall be measured over the specified frequency range using the test setup of figure 7. Repeat the procedures used in 4.8.12.1.

4.8.13 Intercept point (see 3.6.13). The intercept point shall be measured over the specific frequency range using the test setup of figure 8. The test shall be performed at the specified output power. With the test setup stabilized and calibrated, turn signal generator number 2 off. Set signal generator number 1 to some frequency F_1 . Turn signal generator 1 off and 2 on. Set signal generator number 2 to some frequency F_2 . Turn signal generator number 1 on and observe both F_1 and F_2 on the spectrum analyzer. Set the spectrum analyzer controls to display F_1 , F_2 , $2 F_1 - F_2$ and $2 F_2 - F_1$ and measure the amplitude of $2 F_1 - F_2$ and $2 F_2 - F_1$ with respect to the output power level. Record these values, the dc supply voltage and current, the amplifier output power and the frequency of F_1 and F_2 , on the data sheet. Total input power level shall be 10 dB below the input compression point. NOTE: F_1 is the frequency of the signal from RF source 1 and F_2 is the frequency of the signal from RF source 2.

4.8.14 Phase linearity (see 3.6.14). The phase linearity shall be determined over the specified frequency range using the test setup of figure 9. The phase indicator shall be capable of displaying relative phase in degree between the reference and the test channel inputs with an accuracy of $\pm 0.5^\circ + 0.1 \left[\frac{F}{\text{GHz}} \right]$ (degree). A harmonic frequency converter or mixer and their associate components are permitted when it is necessary to extend the frequency range of the test setup. With the amplifier properly biased, the case or heat sink temperature at approximately room ambient and the test setup calibrated, record the phase linearity versus frequency on the X-Y recorder. Draw a best fit straight line through the data and determine the maximum

MIL-A-28875

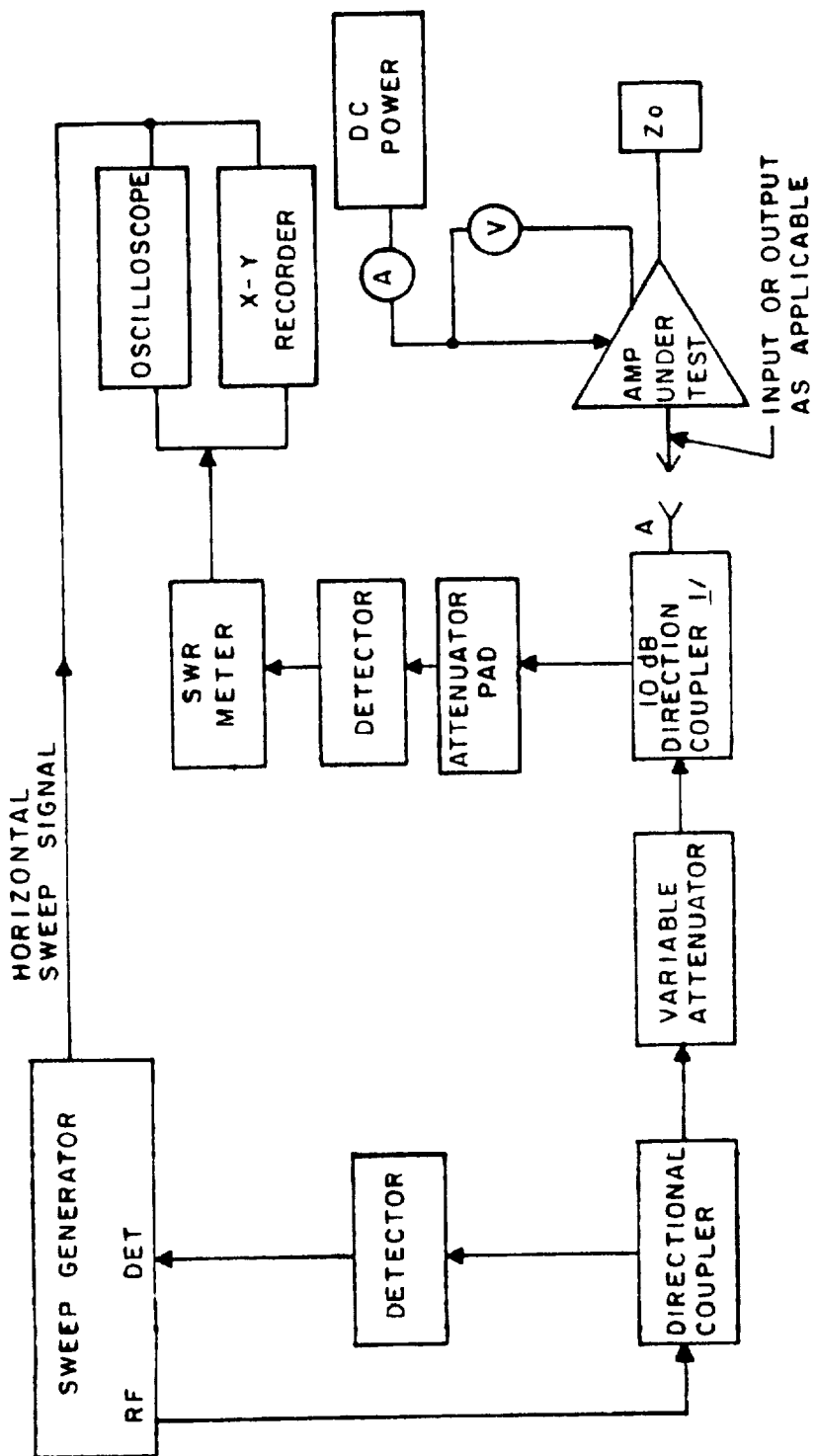

1/ NOTE: The directivity of the directional coupler shall be such as to permit measurement of the VSWR with the appropriate accuracy.

FIGURE 5. VSWR test setup.

MIL-A-28875

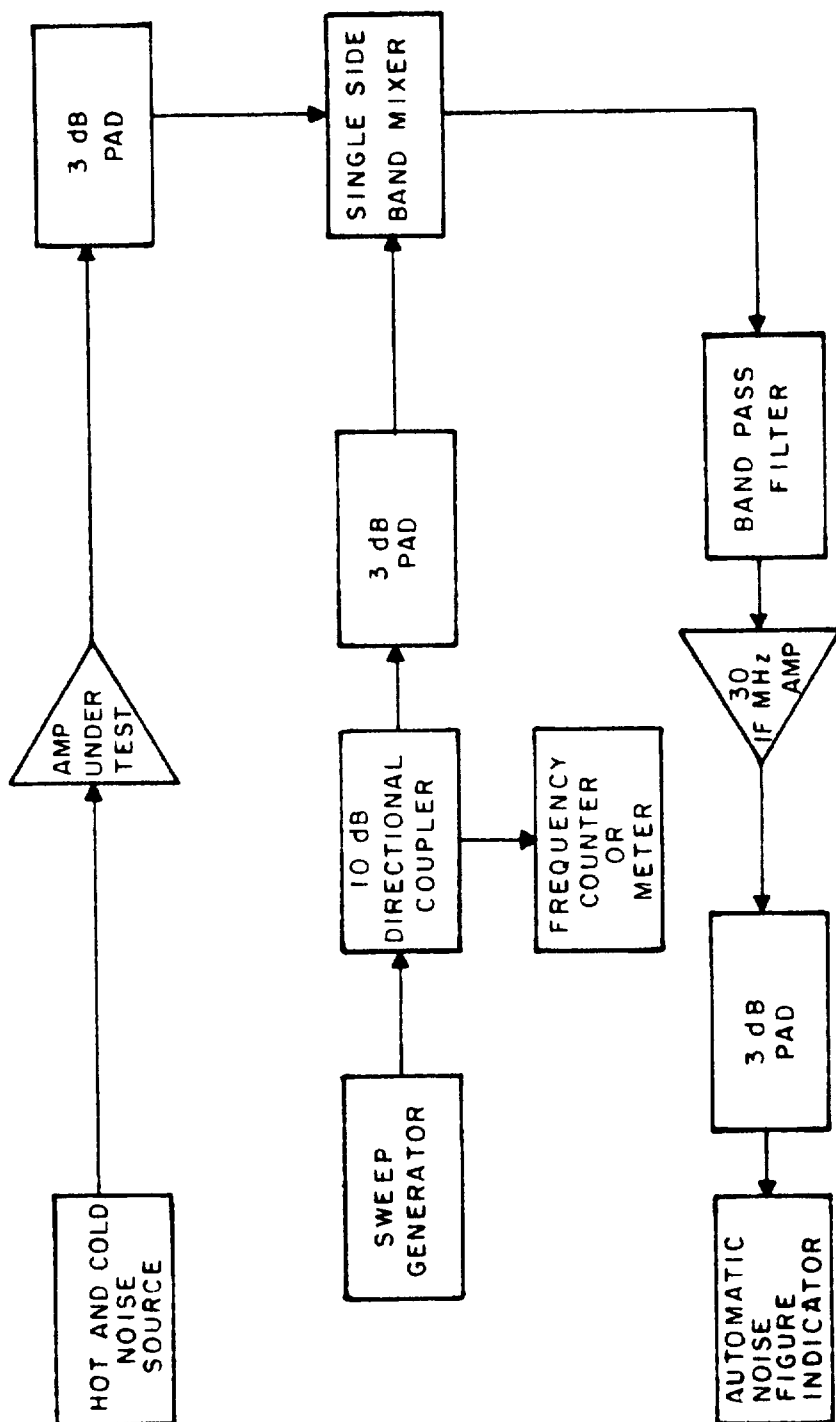

FIGURE 6. Low noise figure test setup.

MIL-A-28875

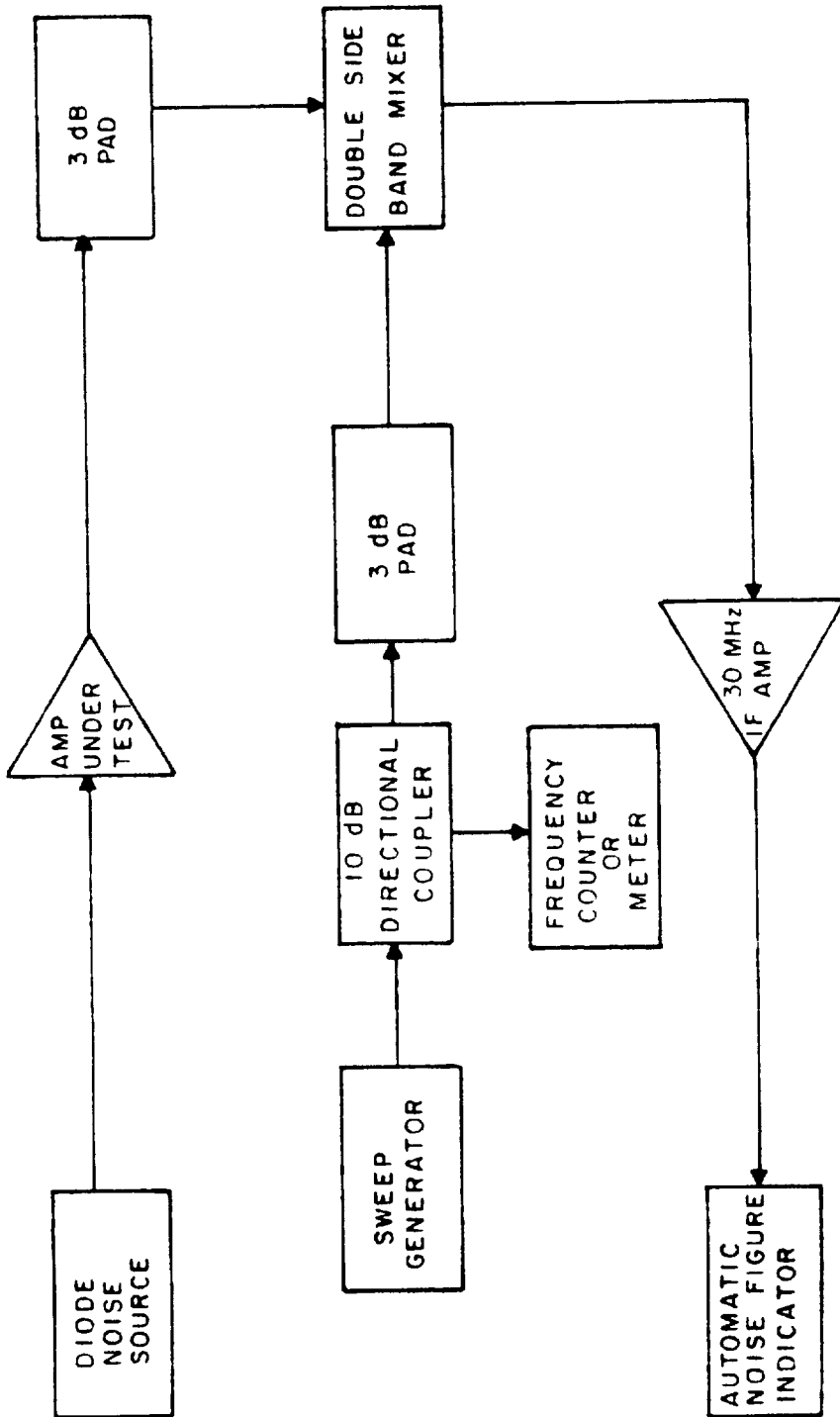

FIGURE 7. Noise figure > 3 dB test setup.

MIL-A-28075

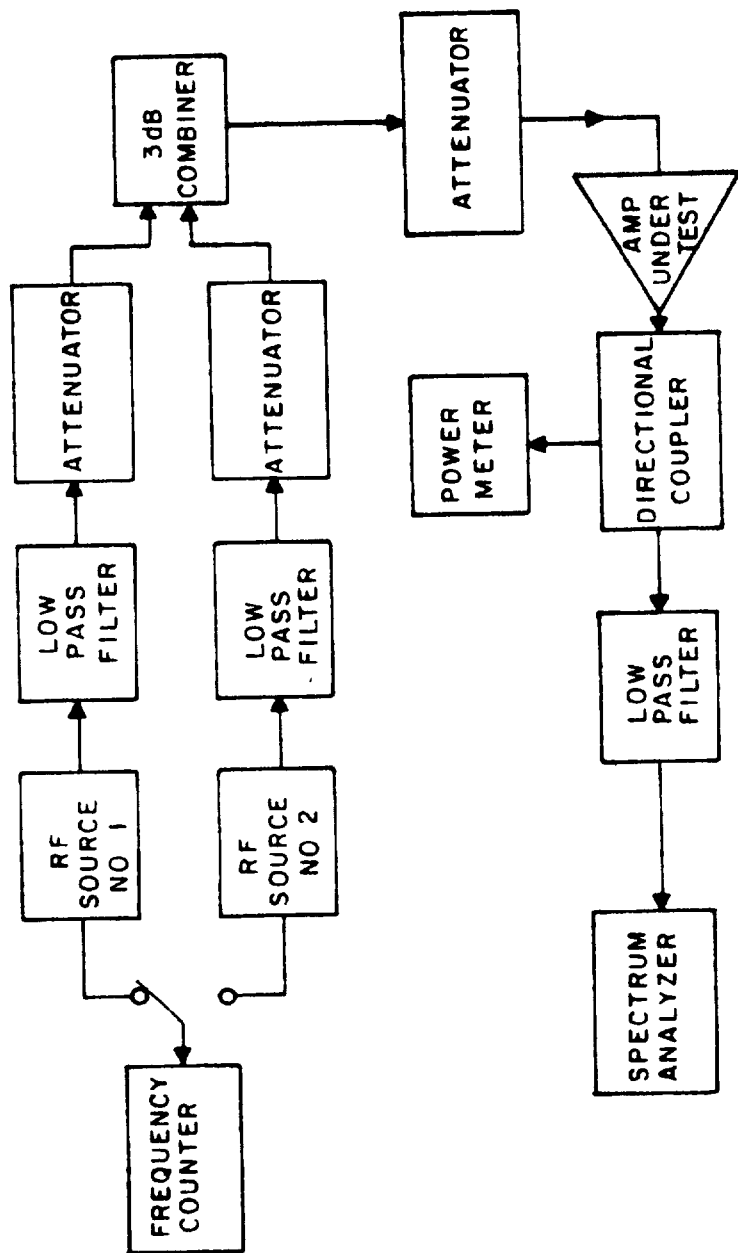

FIGURE 8. Intercept point test setup.

MIL-A-28875

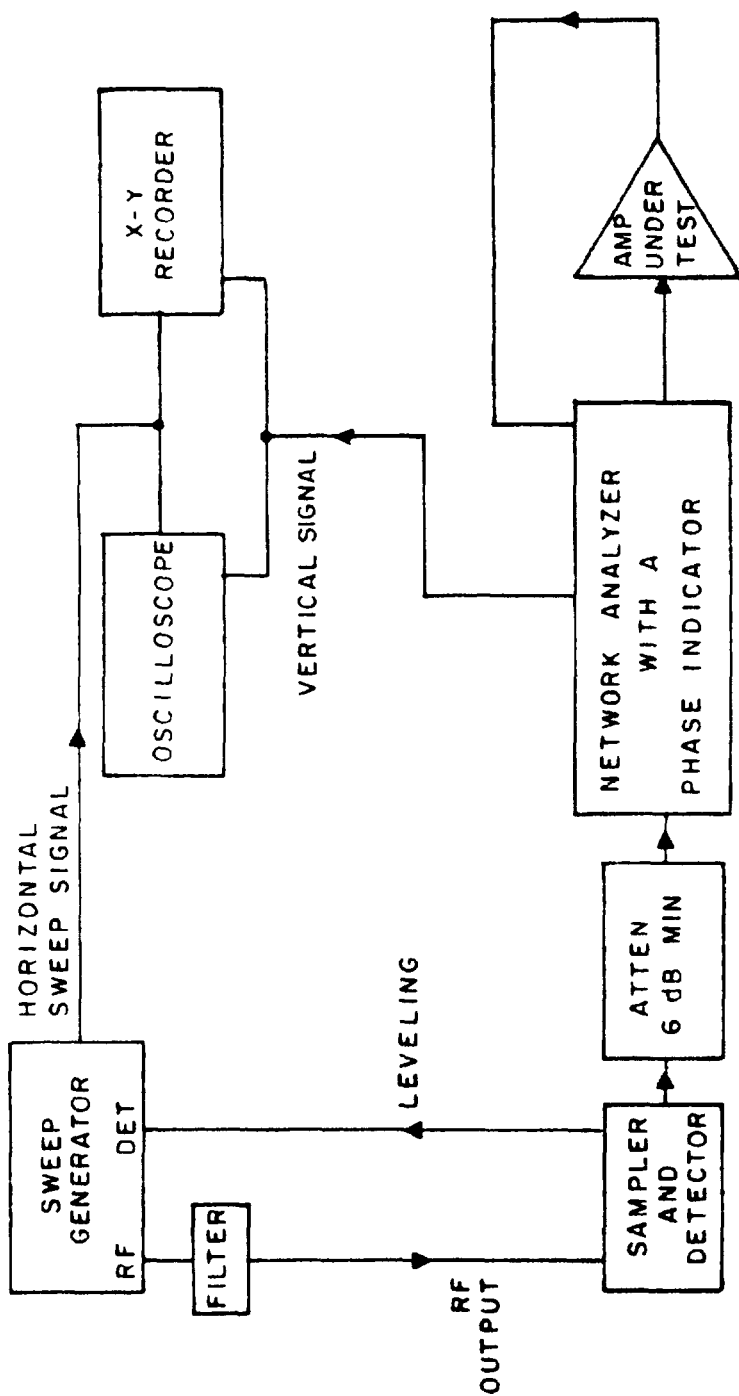

FIGURE 9. Phase linearity test setup.

MIL-A-28875

deviation of the phase linearity from this line. Record this value as the phase linearity on the data sheet. Repeat the above procedure with the amplifier stabilized at the highest specified operating temperature. When determining the phase linearity of a variable gain amplifier, the gain shall be set for maximum.

4.8.15 Group delay (see 3.6.15). The group delay shall be measured across the specified frequency range using the test setup of figure 10 or an automatic network analyzer. The modulation frequency shall be such a value that the resolution is sufficient to measure the fluctuation in the specified group delay. The frequency and amplitude stability of the modulation frequency source shall be such that they will not affect the accuracy of the measurement. With points A and B connected, calibrate the test setup. After the calibration, record calibration lines for different settings of phase zero on the X-Y recorder. Insert the energized amplifier to points A and B and after the case temperature has stabilized at approximately room ambient, make the group delay measurement. From the X-Y recorder, record the maximum group delay value on the data sheet. Repeat the above procedure with the amplifier stabilized at the highest specified operating temperature. When measuring the group delay of a variable gain amplifier, the gain shall be set for maximum.

4.8.16 Amplitude modulation to phase modulation conversion (AM/PM) (see 3.6.16). The AM/PM conversion shall be measured across the specified frequency range using the test setup of figure 11. The power input to the amplifier shall be varied in 0.5 dB steps within the top 5 dB input range of the amplifier. This is accomplished by varying the output amplitude of the squarewave generator. With the test setup stabilized and calibrated, use multiple exposures and photograph the oscilloscope presentation at each input level. From the photographs or plate of the photograph data, determine the variation of the AM/PM conversion with frequency at each input level. From this data, record the widest variation of degree/dB on the data sheet.

4.8.16.1 Amplitude modulation (AM) (see 3.6.16.1). From the photographs or plate of the photograph data developed in 4.8.16, determine the amount of amplitude modulation at the output of the amplifier.

4.8.17 Harmonics and spurious (see 3.6.17). The harmonics and spurious signal levels shall be measured across the specified frequency range using the test setup of figure 12. Set the sweep generator to CW manual, sweep mode and start/stop sweep limits to the specific frequency range. Energize the equipment and bias the amplifier and allow them to be stabilized. With the amplifier operating at the same 1 dB compression point used in 4.8.8, find the fundamental frequency and set a reference on the spectrum analyzer. Locate the 2nd and 3rd harmonics and record their levels (in dB) on the data sheet. Relocate the fundamental frequency and set a reference. Locate and identify the largest spurious signal within and outside the frequency band. Record their frequencies and their levels (in dB) relative to the fundamental frequency on the data sheet.

4.8.17.1 Spurious (see 3.6.17.1). Using the test setup of figure 12 and the general procedure of 4.8.17, locate and identify the largest spurious signal within the specified frequency range and below the 1 dB compressed gain power output level. Record the frequency and the level (in dBc) on the data sheet.

4.8.17.2 Harmonics (see 3.6.17.2). Using the test setup of figure 12 and the general procedure of 4.8.17, determine the sum of all harmonics power within the specified frequency range and at the specified power output level. Record the level (in dBc) on the data sheet.

4.8.18 Logarithmic accuracy and sensitivity (see 3.6.18 and 3.6.19). The logarithmic accuracy and sensitivity shall be measured using the test setup of figure 13. The calibrated attenuator range shall be equal to or greater than the amplifier's dynamic range. The attenuator accuracy shall be at least ± 1 dB. With the equipment and the biased amplifier stabilized, set the generator at the center of the specified frequency range. Starting at the low end of the specified dynamic range, increase the RF input power to the amplifier in 5 dB increments until the entire range is covered. At each increment, record both the input power and output voltage. The output voltage shall be plotted versus the RF input power. From this data, record the worst accuracy and sensitivity values on the data sheet.

MIL-A- 28875

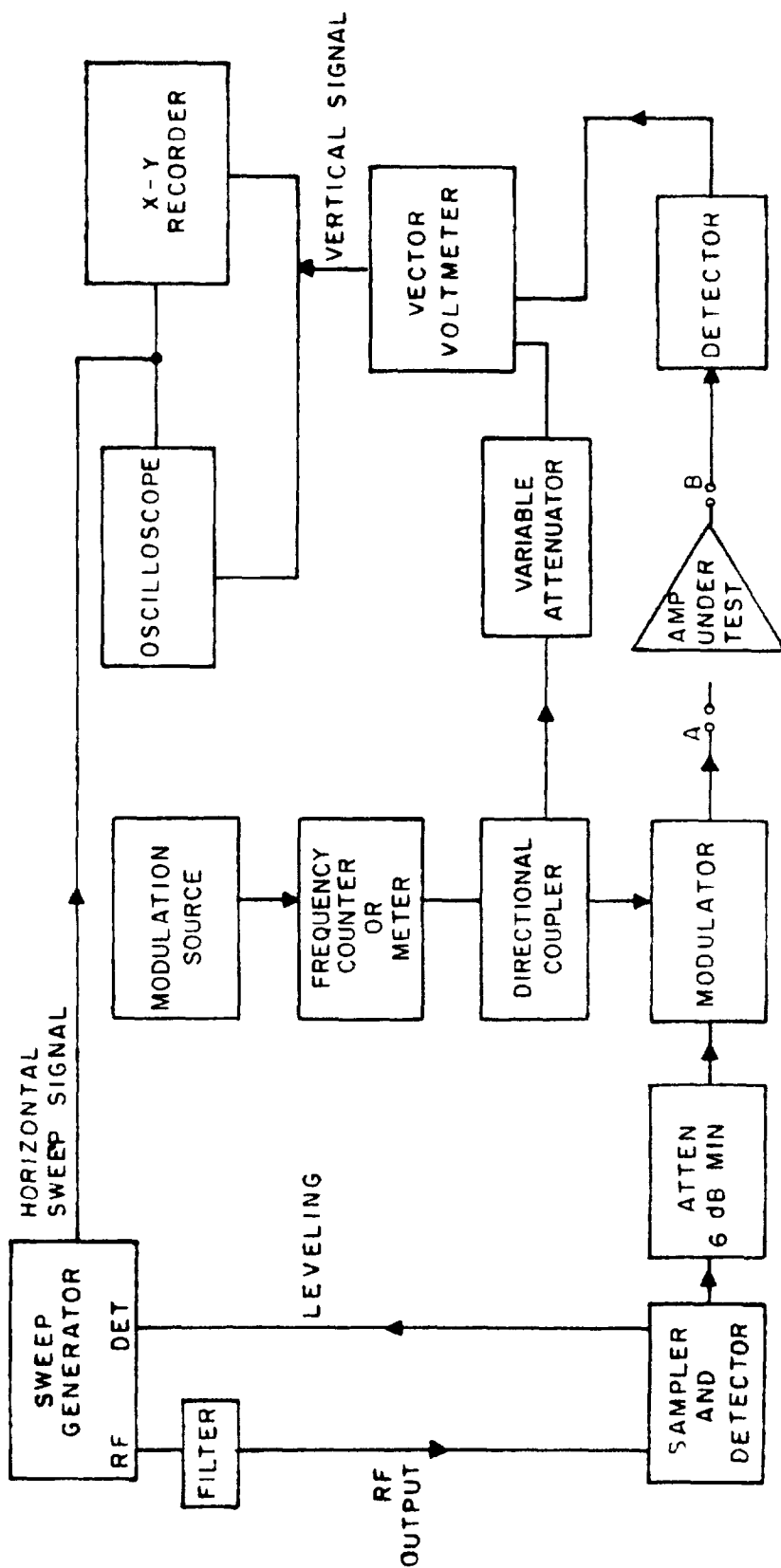

FIGURE 10. Group delay test setup.

MIL-A-28875

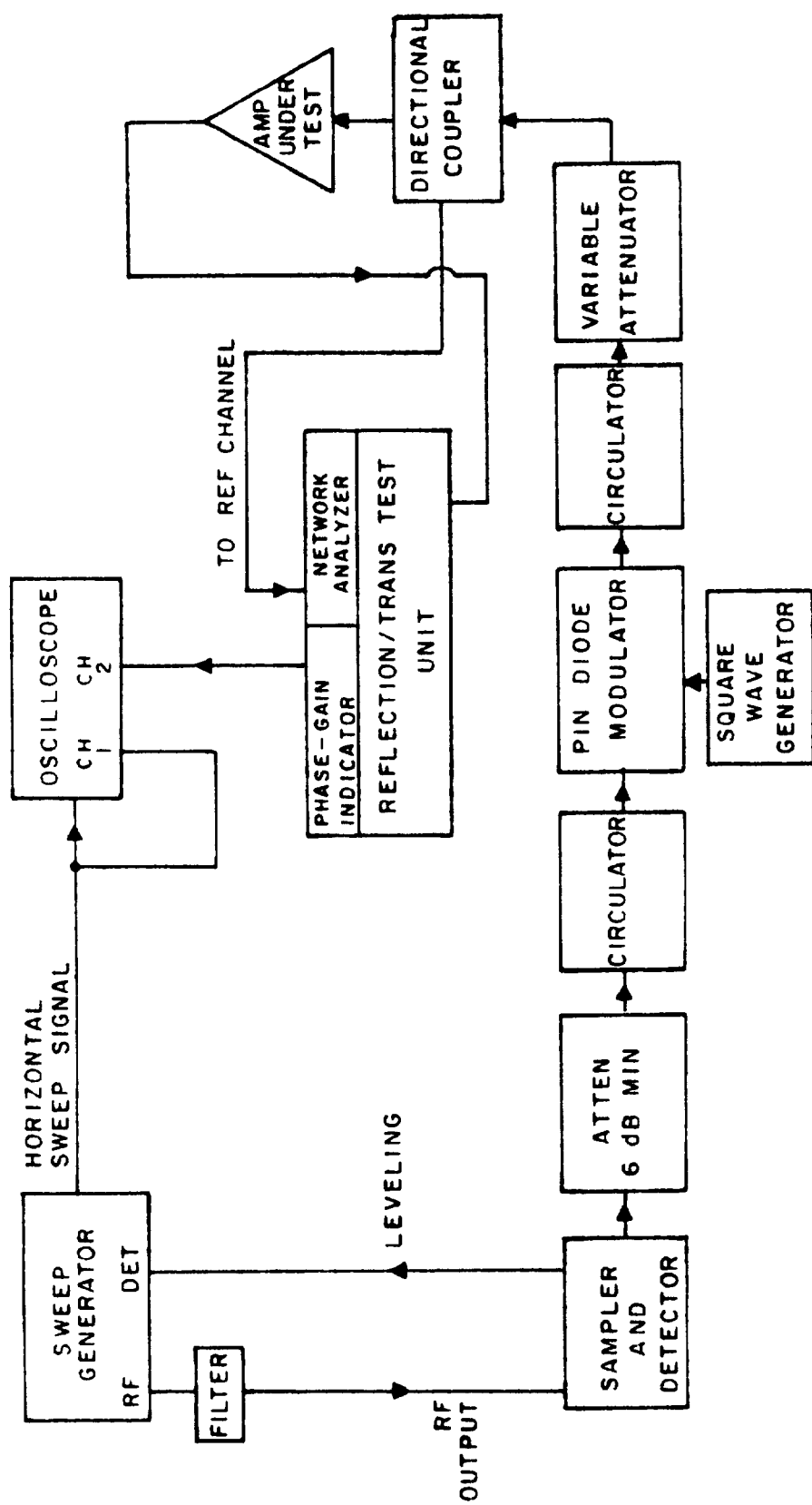

FIGURE 11. AM/PM conversion test setup.

MIL-A-28875

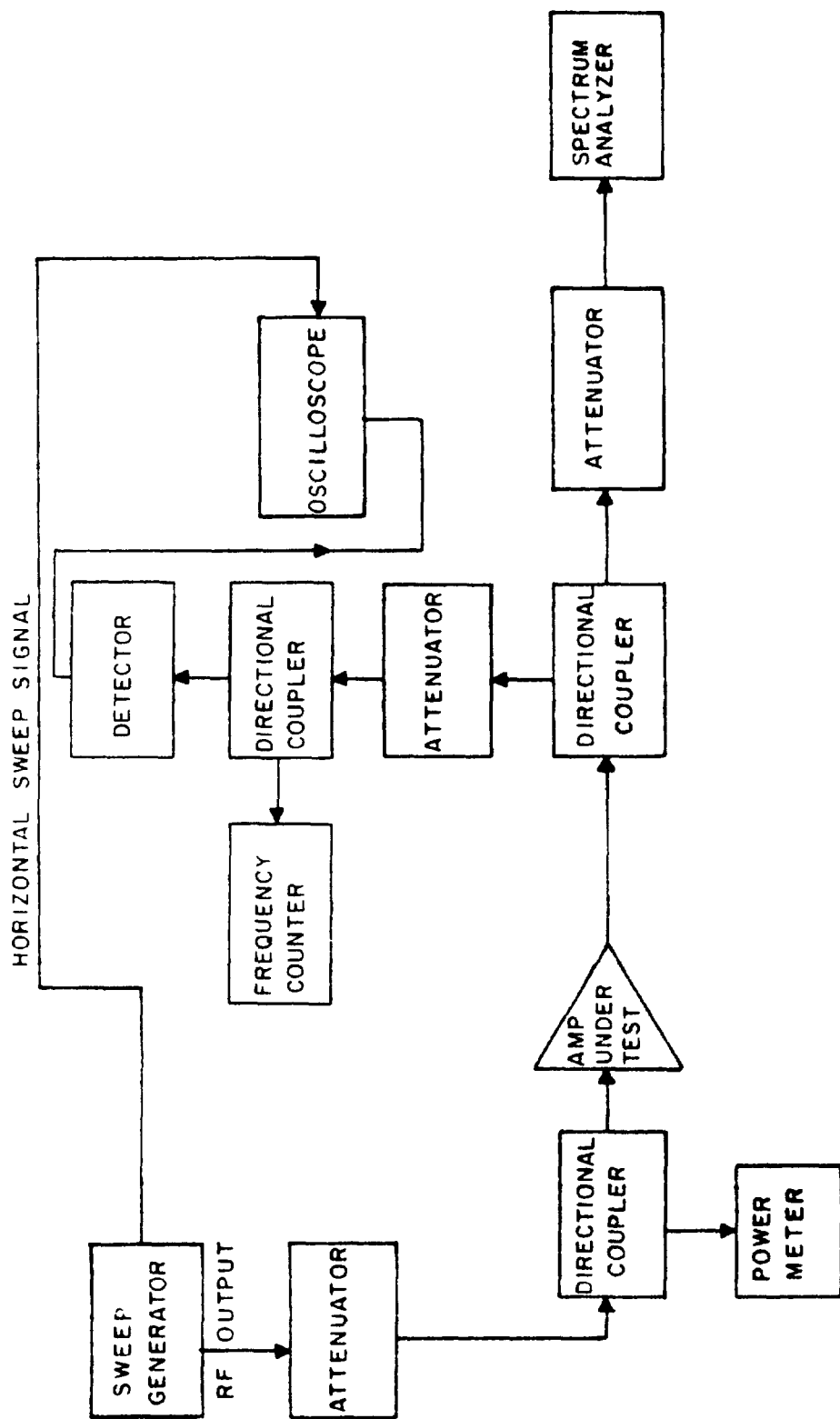

FIGURE 12. Harmonic and spurious test setup.

MIL-A- 28875

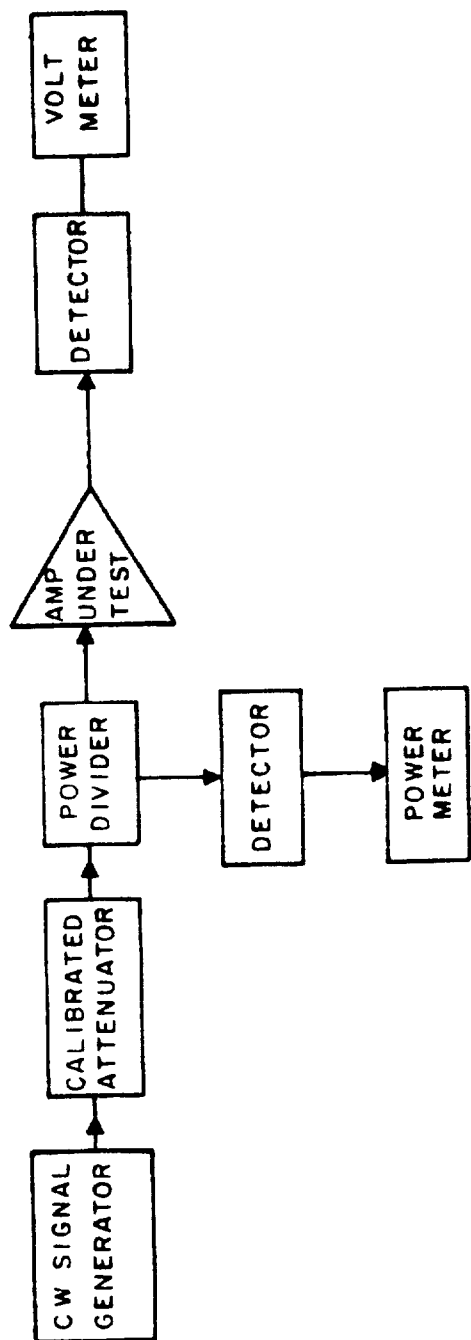

FIGURE 13. Logarithmic accuracy and sensitivity test setup.

MIL-A-28875

4.8.19 Output pulse response (see 3.6.20). The rise time, fall time, droop, overshoot, settling time of the output pulse (see figure 14) shall be measured using the test setup of figures 14A and B. Connect the equipment as shown in figure 14A. Adjust the sweep generator to the specific frequency, either manual sweep mode F_1 to F_2 or CW sweep mode F_1 . Adjust the oscilloscope and pulse generator so as to display and confirm that the RF modulation is a 50 percent duty cycle square wave with maximum possible amplitude and minimum transition times on leading and trailing edges. The power meter will now read 3 dB less than the unmodulated power level. Adjust the sweep generator to achieve a convenient power level which is maintained or noted across the specified frequency range. Once these levels are set, the sweep generator power level must not be adjusted and the 50 percent duty cycle must be maintained for accurate power level readings. After the required power levels have been noted, the pulse width can be adjusted as required. Install amplifier as shown in figure 14B and energize. Adjust the sweep generator frequency and attenuator as required. Adjust the oscilloscope so that the reference waveform and the amplifier's output waveform are displayed at the same time. Note any deformities in the reference pulse shape and subtract these from any similar deformities in the amplifier's output pulse shape. Measure and record the specified pulse characteristic on the data sheet.

4.8.20 Gain vs temperature (see 3.6.21). The gain vs temperature shall be determined at the center of the specified frequency range using the test procedure of 4.8.5, with the exception that the amplifier shall be placed in a temperature chamber. With the amplifier supplied with nominal voltage and current, set the chamber temperature to the lowest specified operating temperature and allow the chamber and the amplifier case or heat sink temperature to stabilize. When stabilization has been obtained, measure the gain of the amplifier. Set the chamber temperature to the highest specified operating temperature and repeat the above procedure. With the values obtained from these measurements, determine the gain vs temperature as the difference between the maximum and minimum gain values. Record this value on the data sheet.

4.8.21 Solderability (see 3.7). The terminals of the amplifier shall be tested in accordance with method 208 of MIL-STD-202. Where applicable a heat sink may be used.

4.8.22 Resistance to soldering heat (see 3.8). Amplifiers shall be tested in accordance with method 210 of MIL-STD-202. The following details and exceptions shall apply:

- a. Special preparation - The terminals shall not have been soldered previously.
- b. Depth of immersion in the molten solder - To a point $1/16 + 1/32$, -0 inch from the body.
- c. Test condition - A.
- d. Cooling time - stabilize to $+25^{\circ}\text{C}$.

4.8.23 Resistance to solvents (see 3.9). Amplifiers shall be tested in accordance with method 215 of MIL-STD-202. All portions of the amplifiers shall be brushed.

4.8.24 Terminal strength/lead integrity (see 3.10). Amplifiers shall be tested as specified in 4.8.24.1 or 4.8.24.2.

4.8.24.1 Terminal strength. Amplifiers with terminals shall be tested in accordance with method 211 of MIL-STD-202, test condition A. The applied force shall be 1.5 pounds.

4.8.24.2 Lead integrity. Amplifiers with leads shall be tested in accordance with method 211 of MIL-STD-202, test condition C. The applied force shall be 8 ± 0.5 ounces. For leads with a section modulus equal to or less than that of a lead with a cross-section of 0.006×0.020 , the force shall be 3 ± 0.3 ounces.

4.8.25 Thermal shock (see 3.11). Amplifiers shall be tested as specified in 4.8.2.2.

MIL-A-28875

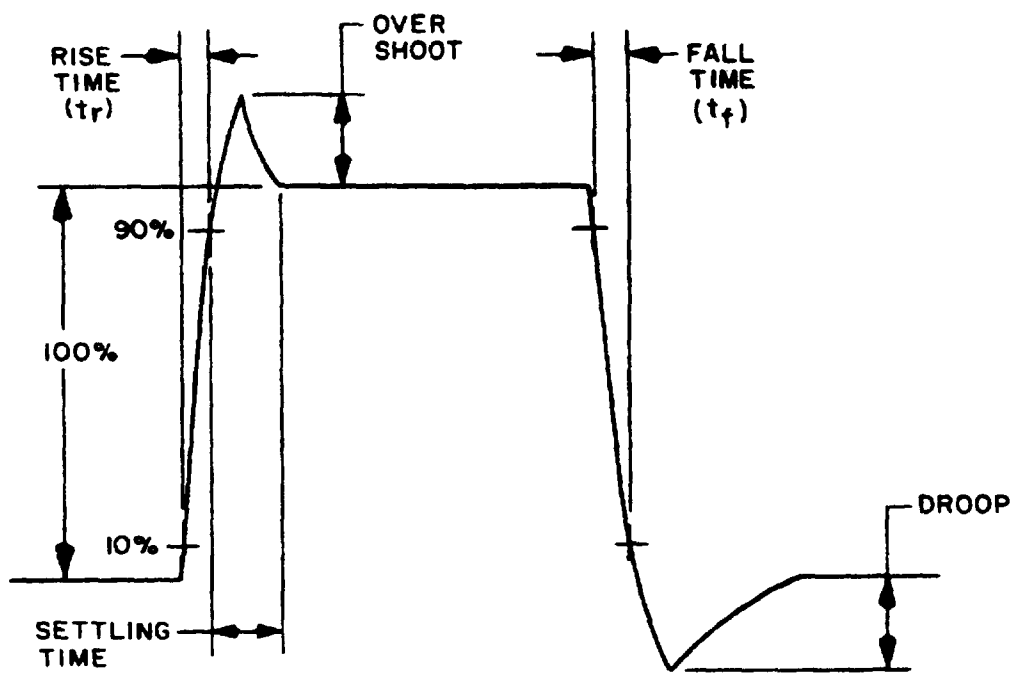
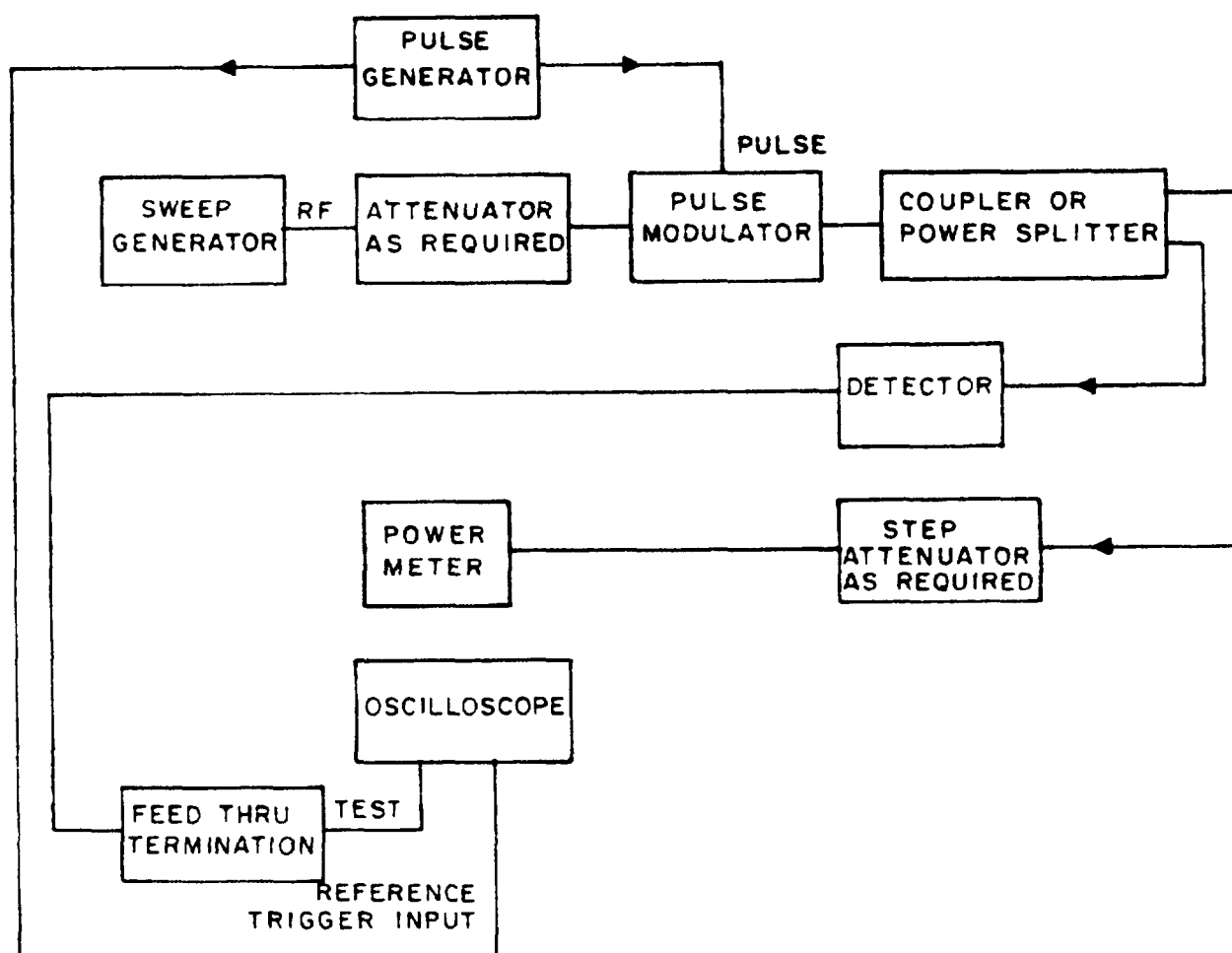
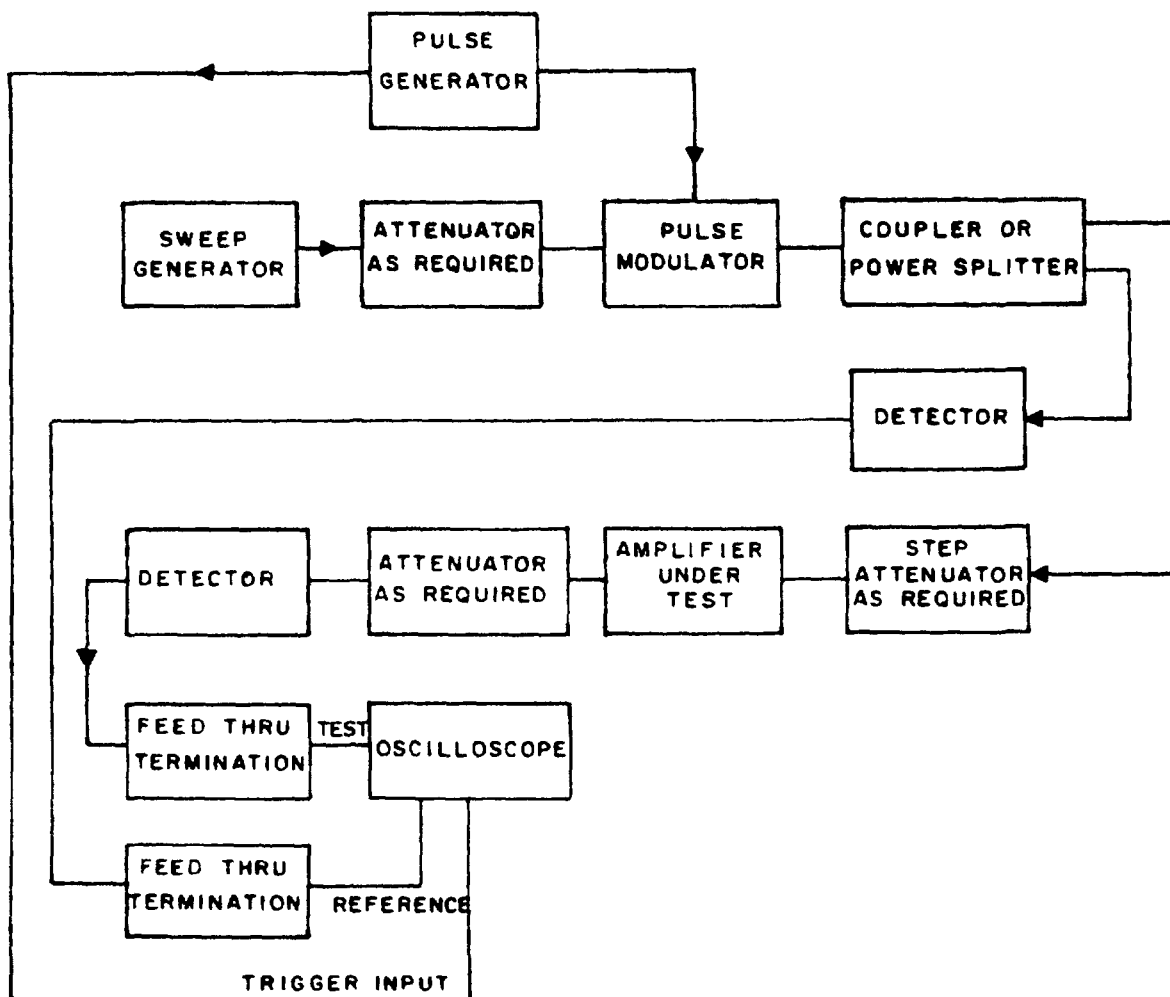

FIGURE 14. Pulse measurements.

MIL-A- 28875

FIGURE 14A. Pulse response calibration setup.

MIL-A- 28875

FIGURE 14B. Output pulse response test setup.

MIL-A-28875

4.8.26 Vibration (see 3.12). Amplifiers shall be tested as specified in 4.8.26.1 or 4.8.26.2. When no method is specified, amplifiers shall be tested as specified in 4.8.26.1.

4.8.26.1 High frequency (nonoperating). Amplifiers shall be tested in accordance with method 204 of MIL-STD-202, test condition B or as specified, with the following details and exceptions:

- a. Amplitude - 0.03 inch double amplitude instead of 0.06.
- b. Resonances - There shall be no resonances at or below 40 Hz.
- c. Mounted by normal means.

4.8.26.2 Random nature. Amplifiers shall be tested in accordance with method 214 of MIL-STD-202, test condition IIF for 15 minutes duration. Mounted by normal means.

4.8.27 Shock (see 3.13). Amplifiers shall be tested as specified in 4.8.27.1, 4.8.27.2, 4.8.27.3, or 4.8.27.4.

4.8.27.1 Waveguide package style. Amplifiers shall be tested in accordance with method 213 of MIL-STD-202, test condition A. Amplifiers shall be mounted by normal means.

4.8.27.2 Flatpack package style. Amplifiers shall be tested in accordance with method 213 of MIL-STD-202, test condition F. Amplifiers shall be mounted by normal means.

4.8.27.3 Coaxial and dual-in-line package styles. Amplifiers shall be tested in accordance with method 213 of MIL-STD-202, test condition J. Amplifiers shall be mounted by normal means.

4.8.27.4 Header and TO package styles. Amplifiers shall be tested in accordance with method 213 of MIL-STD-202, test condition J, except that the peak g's value shall be 15. Amplifiers shall be mounted by normal means.

4.8.28 Acceleration (see 3.14). Amplifiers shall be tested as specified in 4.8.2.3.

4.8.29 Seal (see 3.15). Amplifiers shall be tested as specified in 4.8.2.7.

4.8.30 Barometric pressure (see 3.16). Amplifiers shall be tested in accordance with method 105 of MIL-STD-202. The following shall apply:

- a. Method of mounting - Normal mounting means.
- b. Procedures - With the amplifier nonoperating, decrease the chamber pressure to 8.00 mm of Hg (0.315 inches of Hg or 100,000 feet above sea level) at a rate not to exceed 2,000 fpm. Maintain this pressure for 1 hour and then increase the chamber pressure to 439.00 mm of Hg (17.3 inches of Hg or 15,000 feet) at a rate not to exceed 2000 fpm. Allow the chamber to stabilize at this pressure and then energize the amplifier. After the amplifier is stabilized, perform the tests as specified in 3.16.

4.8.31 Temperature extreme (see 3.17). Amplifiers shall be tested at both the specified operating high temperature and low temperature values. Amplifiers shall first be tested at the low temperature and then the high temperature. Prior to any measurements, the amplifier case or heat sink temperature shall stabilize.

4.8.32 Moisture resistance (see 3.18). Amplifiers shall be tested in accordance with method 106 of MIL-STD-202, except omit steps 7A and 7B. Loading voltage is not applicable.

4.8.33 Salt spray (see 3.19). Amplifiers shall be tested in accordance with method 101 of MIL-STD-202, test condition B. The mounting shall be with normal mounting means.

MIL-A-28875

4.8.34 Sand and dust (see 3.20). Amplifiers shall be tested in accordance with method 110 of MIL-STD-202.

4.8.35 Explosion (see 3.21). Amplifiers shall be tested in accordance with method 109 of MIL-STD-202.

4.8.36 Electromagnetic interference (see 3.22). Amplifiers shall be tested in accordance with MIL-STD-462. Limits of MIL-STD-461 shall apply for test methods CE03, CS01, CS02, CS04, CS06, and RE02.

4.8.37 Operating life (see 3.23). Amplifiers shall be tested in the same manner as specified in 4.8.3, except the time shall be 1000 hours.

5. PACKAGING

5.1 Preservation. Preservation shall be level A or C, as specified (see 6.2).

5.1.1 Level A.

5.1.1.1 Cleaning. Amplifiers shall be cleaned in accordance with MIL-P-116, process C-1.

5.1.1.2 Drying. Amplifiers shall be dried in accordance with MIL-P-116.

5.1.1.3 Preservative application. Preservatives shall not be used.

5.1.1.4 Unit packs. Each amplifier shall be individually unit packed in accordance with MIL-P-116, submethod IA-8, insuring compliance with the applicable requirements of that specification. Cushioning shall conform to PPP-C-1842, type III or MIL-P-81997, type II. The unit container shall meet the requirements of MIL-B-117, type I, class F, style 1. Each amplifier exceeding one inch in overall thickness or four inches in overall length shall be placed in a supplementary container conforming to PPP-B-566, PPP-B-676 or PPP-B-636.

5.1.1.5 Intermediate packs. Amplifiers, unit packed in bags or envelopes as specified in 5.1.1.4, shall be placed in intermediate containers conforming to PPP-B-566, PPP-B-676 or PPP-B-636. Intermediate containers shall be uniform in size, shape and quantities, shall be of minimum tare and cube and shall contain multiples of five unit packs, not to exceed 100 unit packs. No intermediate packs are required when the total quantity shipped to a single destination is less than 100 unit packs or when supplementary containers are used.

5.1.2 Level C. The level C preservation of amplifiers shall conform to the MIL-STD-794 requirements for this level.

5.2 Packing. Packing shall be level A, B or C, as specified (see 6.2).

5.2.1 Level A. The packaged amplifiers shall be packed in fiberboard containers conforming to PPP-B-636, class weather resistant, style optional, special requirements. The requirements for box closure, waterproofing and reinforcing shall be in accordance with method V of the PPP-B-636 appendix.

5.2.2 Level B. The packaged amplifiers shall be packed in fiberboard containers conforming to PPP-B-636, class domestic, style optional, special requirements. Closures shall be in accordance with the appendix thereto.

5.2.3 Level C. The level C packing for amplifiers shall conform to the MIL-STD-794 requirements for this level.

5.3 Marking. In addition to any special or other identification marking required by the contract (see 6.2), each unit pack, intermediate, supplementary and exterior container shall be marked in accordance with MIL-STD-129. All unit, supplementary, intermediate and exterior containers shall be marked as specified for sensitive electronic devices in MIL-STD-129.

5.4 General.

MIL-A-28875

5.4.1 Exterior containers. Exterior containers (see 5.2.1, 5.2.2 and 5.2.3) shall be of a minimum tare and cube consistent with the protection required and shall contain equal quantities of identical stock numbered items to the greatest extent practicable.

5.4.2 Packaging inspection. The inspection of these packaging requirements shall be in accordance with 4.7.3.

5.4.3 Army acquisitions.

5.4.3.1 Level A intermediate packs. All supplementary and intermediate containers shall be either weather (or water) resistant or overwrapped with waterproof barrier materials (see 5.1.1.4 and 5.1.1.5).

5.4.3.2 Level A and level B packing. For level A packing, the fiberboard containers shall not be banded but shall be placed in a close fitting box conforming to PPP-B-601, overseas type; PPP-B-621, class 2, style 4 or PPP-B-585, class 3, style 2 or 3. Closure and strapping shall be in accordance with applicable container specification except that metal strapping shall conform to QQ-S-781, type I, finish A. When the gross weight exceeds 200 pounds or the container length and width is 48 x 24 inches or more and the weight exceeds 100 pounds, 3 x 4 inch skids (laid flat) shall be applied in accordance with the requirements of the container specification. If not described in the container specification, the skids shall be applied in a manner which will adequately support the item and facilitate the use of material handling equipment. For level B packing, fiberboard boxes shall be weather resistant as specified in level A and the containers shall be banded (see 5.2.1 and 5.2.2).

6. NOTES

6.1 Intended use. Amplifiers covered by this specification are intended for use in military equipment and systems for signal amplification or limiting and power amplification.

6.2 Ordering data. Acquisition documents should specify the following:

- a. Title, number and date of this specification.
- b. Title, number, and date of the applicable specification sheet, and the military part number.
- c. Levels of preservation and packing required (see 5.1 and 5.2).
- d. If special or other identification marking is required (see 5.3).

6.3 Qualification. With respect to products requiring qualification, awards will be made only for products which are at the time set for opening of bids, qualified for inclusion in applicable qualified products list whether or not such products have actually been so listed by that date. The attention of the contractors is called to this requirement, and manufacturers are urged to arrange to have the products that they propose to offer to the Federal Government tested for qualification in order that they may be eligible to be awarded contracts for the products covered by this specification. The activity responsible for the qualified products list is the Naval Electronic Systems Command, ELEX 8111, Department of the Navy, Washington, DC 20363; however, information pertaining to qualification of products may be obtained from the Defense Electronics Supply Center (DESC-E), Dayton, OH 45444.

6.3.1 Copies of "Provisions Governing Qualification" SD-6 may be obtained upon application to Commanding Officer, Naval Publications and Forms Center, 5801 Tabor Avenue, Philadelphia, PA 19120.

6.4 First article inspection. Information pertaining to first article inspection of products covered by this specification should be obtained from the acquiring activity for the specific contracts involved (see 3.3).

MIL-A- 28875

6.5 Definitions. For the purpose of this specification, the following definitions shall apply:

6.5.1 Intercept point. The intercept point is defined as the point where extensions of the first and third order response intercept on the output power scale. Where the third order is $3 f_1, 3 f_2, 2 f_1 * f_2, 2 f_2 * f_1$. The second order ($2 f_1, 2 f_2, f_1 * f_2$) response plot will generally intercept near the same point unless the amplifier design suppresses even order response (e.g. push-pull stage).

6.5.2 Phase linearity. Phase linearity is defined as the maximum deviation from the ideal straight line versus frequency plot which would be produced by an ideal transmission line of similar electrical length.

6.5.3 Group delay. Group delay is defined as the rate of change of the phase shift of the modulation envelope versus changes in power frequency.

6.5.4 AM/PM conversion. AM/PM conversion is defined as a slight shift of the amplifier phase delay as the signal amplitude is increased above the point where some degree of gain compression is produced.

6.5.5 Pulse droop (or sag). Pulse droop is defined as the amount that the amplitude of the output pulse will decrease in a given amount of time, with a fixed DC level applied to the amplifier's input.

6.5.6 Pulse overshoot. Pulse overshoot is defined as the difference between the peak amplitude of the output pulse and the final amplitude at the pulse leading edge.

6.6 Occupation safety and health administration (OSHA). OSHA review completed, no further review required.

Custodians
 Army - ER
 Navy - EC
 Air Force - 85

Preparing activity:
 Navy - EC
 (Project 5985-0968)

Review activities.
 Army - MI
 Navy - OS, SH
 Air Force - 11, 17, 99
 DLA - ES

User activities:
 Army - AV
 Navy - AS, MC
 Air Force - 19

Agent:
 DLA - ES

INSTRUCTIONS: In a continuing effort to make our standardization documents better, the DoD provides this form for use in submitting comments and suggestions for improvements. All users of military standardization documents are invited to provide suggestions. This form may be detached, folded along the lines indicated, taped along the loose edge (DO NOT STAPLE), and mailed. In block 5, be as specific as possible about particular problem areas such as wording which required interpretation, was too rigid, restrictive, loose, ambiguous, or was incompatible, and give proposed wording changes which would alleviate the problems. Enter in block 6 any remarks not related to a specific paragraph of the document. If block 7 is filled out, an acknowledgement will be mailed to you within 30 days to let you know that your comments were received and are being considered.

NOTE This form may not be used to request copies of documents, nor to request waivers, deviations, or clarification of specification requirements on current contracts. Comments submitted on this form do not constitute or imply authorization to waive any portion of the referenced document(s) or to amend contractual requirements.

(Fold along this line)

(Fold along this line)

DEPARTMENT OF THE NAVY

Naval Electronic Systems Command
Washington, DC 20363



NO POSTAGE
NECESSARY
IF MAILED
IN THE
UNITED STATES

OFFICIAL BUSINESS
PENALTY FOR PRIVATE USE \$300

BUSINESS REPLY MAIL
FIRST CLASS PERMIT NO 12503 WASHINGTON D C

POSTAGE WILL BE PAID BY THE DEPARTMENT OF THE NAVY

COMMANDER
NAVAL ELECTRONIC SYSTEMS COMMAND
DEFENSE STANDARDIZATION PROGRAM BRANCH
DEPARTMENT OF THE NAVY
WASHINGTON, DC 20363
ATTN: ELEX 8111

