

INCH-POUND

MIL-PRF-87961B
13 December 2013
SUPERSEDING
MIL-PRF-87961A
08 September 1998

PERFORMANCE SPECIFICATION

HOSE AND HOSE ASSEMBLIES, AIR DUCT, AIR BREATHING, OXYGEN SYSTEM

This specification is approved for use by all Departments and Agencies of the Department of Defense.

1. SCOPE

1.1 Scope. This specification covers the requirements for hose and hose assemblies (see 6.9) which supply breathing oxygen to aircrews during the operation of high performance aircraft.

1.2 Classification. Hoses and hose assemblies covered by this specification are of the following types with lengths as identified in figures 1, 4, and 5 (see 6.2 and 6.10).

Type I	Hose with end covers and outer covering
Type II	Type I hose with MS22058-1 connector and NAS397-18 clamp
Type III	Type I hose with MS22058-2 connector, NAS397-18 clamp and retainer strap, P/N 7225317-10

2. APPLICABLE DOCUMENTS

2.1 General. The documents listed in this section are specified in sections 3, 4, or 5 of this specification. This section does not include documents cited in other sections of this specification or recommended for additional information or as examples. While every effort has been made to ensure the completeness of this list, document users are cautioned that they must meet all specified requirements of the documents cited in sections 3, 4, or 5 of this specification, whether or not they are listed.

Comments, suggestions, or questions on this document should be addressed to Oklahoma City Air Logistics Center/ENSDAA, 3001 Staff Drive, Suite 1AB81A, Tinker AFB, OK 73145 or emailed to af71@tinker.af.mil . Since contact information can change, you may want to verify the currency of this address information using the ASSIST database at https://assist.dla.mil .

MIL-PRF-87961B

2.2 Government documents.

2.2.1 Specifications and standards. The following specifications and standards form a part of this document to the extent specified herein. Unless otherwise specified, the issues of these documents are those cited in the solicitation or contract.

FEDERAL SPECIFICATIONS

A-A-59155	- Nitrogen, High Purity, Special Purpose
A-A-59503	- Nitrogen, Technical

FEDERAL STANDARDS

FED-STD-191	- Textile Test Methods
FED-STD-595/34410	- Green, Flat or Lusterless

DEPARTMENT OF DEFENSE SPECIFICATIONS

MS22058	- Connector, Oxygen Hose to Regulator
---------	---------------------------------------

(Copies of these documents are available online at <https://assist.dla.mil/> or from the Standardization Document Order Desk, 700 Robbins Avenue, Building 4D, Philadelphia, PA 19111-5094.)

2.2.2 Other government documents, drawings, and publications. The following other government documents, drawings, and publications form a part of this document to the extent specified herein. Unless otherwise specified, the issues are those cited in the solicitation or contract.

DRAWINGS, AIR FORCE

7225317	- Retainer Strap Assembly – Hose, Connector to Regulator
---------	--

(Copies of the drawing are available from the procuring activity or OC-ALC/ENSDAA Public Sales Desk, Tinker AFB, OK 73145.)

2.3 Non-government publications. The following documents form a part of this document to the extent specified herein. Unless otherwise specified, the issues of these documents are those cited in the solicitation or contract.

AEROSPACE INDUSTRIES ASSOCIATION of AMERICA, INC. (AIA)

NAS397	- Clamp - Ratchet, One Piece
--------	------------------------------

(NA/NAS documents may be obtained online at www.aia-aerospace.org/ or from Aerospace Industries Association 1000 Wilson Boulevard, Suite 1700 Arlington, VA 22209-3928.)

MIL-PRF-87961B

AMERICAN SOCIETY FOR QUALITY (ASQ)

- ASQC-Z1.4 - Sampling Procedures and Tables for Inspection by Attributes (DoD Adopted)

(ASQ documents may be obtained online at <http://www.asq.org/> or from American Society for Quality, P.O. Box 3005, Milwaukee, WI 53201-3005 or 600 North Plankinton Avenue, Milwaukee, WI 53203.)

AMERICAN SOCIETY FOR TESTING AND MATERIALS (ASTM)

- ASTM-D1149 - Rubber Deterioration-Surface Ozone Cracking in a Chamber (DoD Adopted)

(ASTM documents may be obtained online at <http://www.astm.org/> or from American Society for Testing and Materials, 100 Barr Harbor Drive, P.O. Box C700, West Conshohocken, PA 19428-2959.)

PARACHUTE INDUSTRY ASSOCIATION (PIA)

- PIA-C-419 - Cloth, Duck, Cotton, Unbleached, Plied-Yarns Army and Numbered

(PIA documents may be obtained online at <http://pia.com> or from PIA 3833 West Oakton Street Skokie, IL 60076.)

SOCIETY OF AUTOMOTIVE ENGINEERS (SAE)

- SAE-AS1065 - Quality & Serviceability Requirements for Aircraft Cylinder Assemblies Charged with Aviator's Breathing Oxygen
- SAE-AS1933 - Hose Containing Age-Sensitive Elastomeric Material, Age Controls for
- SAE AS8010 - Aviator's Breathing Oxygen Purity Standard

(SAE documents may be obtained online at <http://www.sae.org/> or from SAE World Headquarters, 400 Commonwealth Drive, Warrendale, PA 15096-0001 USA.)

2.4 Order of precedence. Unless otherwise noted herein or in the event of a conflict between the text of this document and the references cited herein, the text of this document takes precedence. Nothing in this document, however, supersedes applicable laws and regulations unless a specific exemption has been obtained.

3. REQUIREMENTS

MIL-PRF-87961B

3.1 First article. When specified (see 6.2), the hose or hose assembly, shall be subjected to first article inspection in accordance with 4.2.

3.2 Recycled, recovered, or environmentally preferable materials. Recycled, recovered, or environmentally preferable materials should be used to the maximum extent possible, provided that the material meets or exceeds the operational and maintenance requirements, and promotes economically advantageous life cycle costs.

3.3 Materials. All materials shall be suitably treated to resist corrosion due to electrolytic decomposition and any other atmospheric condition that may be encountered during operational use and storage (see 6.3). The use of toxic chemicals, hazardous substances, or ozone depleting chemicals shall be avoided, whenever feasible.

3.3.1 Safety specific materials. All materials used shall be capable of operating in a pure oxygen environment without creating a health or fire hazard (see 6.9). Cadmium shall not be used.

3.3.2 Ozone resistance. Elastomer components and end covers shall be composed of ozone resistant materials (see 6.3).

3.4 Interface.

3.4.1 Color. The hose outer covering shall be lusterless green, color 34410 of FED-STD-595. Unless otherwise specified in the acquisition document (see 6.2). The end cover shall be lusterless green, color 34410 of FED-STD-595.

3.4.2 Fittings. The hose and end covers shall be compatible with MS22058 connectors and NAS397 clamps.

3.4.3 Dimensions. The hose shall conform to the dimensions shown figure 1 3, 4, or 5.

3.5 Performance.

3.5.1 Components.

3.5.1.1 Hose reinforcement. The hose shall be reinforced (see 6.4 and figure 2).

3.5.1.2 End cover. The ends of the hose shall be provided with an end cover (see figures 1 through 3).

3.5.1.3 Outer covering. The hose shall be provided with an outer covering (see 6.9).

3.5.2 Odor. The hose shall be odorless.

MIL-PRF-87961B

3.5.3 Cleanliness. All surfaces shall be free of visible particulates (50 microns and larger), free of visible fluorinated lubricants, and free of hydrocarbon contamination to a level not greater than 3 milligrams per square foot (mg/ft^2) (see 6.5).

3.5.4 Flexibility. The hose shall withstand being coiled around a 1.75 inch diameter rod, and then twisted 360° or 720° for hoses under or over 30 inches in length, respectively, in each direction about the longitudinal axis.

3.5.5 Delamination. Under a vacuum, the inner layer of the hose shall not delaminate.

3.5.6 Elongation. When suspended in the vertical position with a load, the hose elongation shall be between 3% and 10% of the original length. Any permanent set (see 6.9) shall not exceed 5% of the original length.

3.5.7 Leakage. The hose shall not leak in excess of 0.25 cm^3 per minute per foot of hose, when pressurized to 10 psi gage (psig).

3.5.8 Tensile load. The hose assembly shall withstand a 40 pound tensile load.

3.5.9 Static load. Under a static load of 125 pounds per 4 inch section, the outside diameter shall not be decreased more than 15% of the original value. After removal of the static load, the outside diameter of the hose shall be within 5% of the original outside diameter.

3.5.10 High temperature. The hose shall withstand exposure to $160^\circ \pm 5^\circ\text{F}$ for 48 hours.

3.5.11 Low temperature. The hose shall withstand exposure to $-40^\circ \pm 5^\circ\text{F}$ for 30 minutes.

3.5.12 Abrasion. The hose shall withstand abrasion simulating usage (see 6.6).

3.5.13 Flexibility endurance. The hose shall withstand 500 cycles of being coiled and released around a rod, 1.75 inch diameter, and then 500 cycles of being twisted 270° about the longitudinal axis in both directions.

3.5.14 Burst pressure. The burst pressure of the hose shall exceed 20 psi (see 6.9).

3.5.15 Age. The hose shall be no more than 12 months old from the cure date to the acceptance date, as defined in SAE-AS1933.

3.5.16 Weight. The hose shall not exceed 5.0 ounces per foot of length.

3.5.17 Identification. The hose shall be permanently and legibly marked with the following data (see 6.2):

- a. Nomenclature
- b. Cure date.
- c. PIN.

MIL-PRF-87961B

- d. Manufacturer's CAGE code.
- e. Manufacturer's part number.

3.6 Interchangeability. All parts having the same manufacturer's part number shall be functionally and dimensionally interchangeable.

4. VERIFICATION

4.1 Classification of inspections. The inspection requirements specified herein are classified as follows:

- a. First article (see 4.2).
- b. Conformance inspection (see 4.3).

4.2 First article inspection. First inspection shall be performed on 3 hoses and shall consist of all tests in section 4.6.

4.3 Conformance inspection. Conformance inspection shall consist of the individual tests in 4.3.1 and the sampling tests in 4.3.2.

4.3.1 Individual tests. Each hose shall be subjected to the following tests:

- a. Examination (see 4.6.1)
- b. Delamination (see 4.6.5)
- c. Leakage (see 4.6.7)

4.3.2 Sampling tests. Sampling tests shall be performed in accordance with the guidance in ASQC-Z1.4. Sampling shall begin at the normal inspection level (see 6.7). The sampling tests are:

- a. Odor (see 4.6.2)
- b. Cleanliness (see 4.6.3)
- c. Flexibility (see 4.6.4)
- d. Elongation (see 4.6.6)

4.4 Test conditions. Unless otherwise specified in the individual test description, all tests shall be performed under the following test conditions:

- a. Ambient atmospheric conditions.
- b. First article tests shall be performed using oxygen conforming to Type I of SAE-AS8010. Individual tests shall be performed using oxygen conforming to Type I of SAE-AS8010 or water pumped nitrogen conforming to Type I, Class 1, Grade B of A-A-59503 and A-A-59155.

MIL-PRF-87961B

4.5 Requirements cross-reference matrix. Table I provides a cross-reference matrix of the section 3 requirements tested or verified in the paragraphs below.

TABLE I. Requirements cross-reference matrix

Requirement	Verification	Requirement	Verification
3.1	4.2	3.5.6	4.6.6
3.3	4.6.1	3.5.7	4.6.7
3.3.1	4.6.1, 4.6.2, 4.6.3	3.5.8	4.6.8
3.3.2	4.6.16	3.5.9	4.6.9
3.4.1	4.6.1	3.5.10	4.6.10
3.4.2	4.6.1	3.5.11	4.6.11
3.4.3	4.6.1	3.5.12	4.6.12
3.5.1.1	4.6.6, 4.6.8, 4.6.9	3.5.13	4.6.13
3.5.1.2	4.6.1	3.5.14	4.6.14
3.5.1.3	4.6.1	3.5.15	4.6.15
3.5.2	4.6.2	3.5.16	4.6.1
3.5.3	4.6.3	3.5.17	4.6.1
3.5.4	4.6.4	3.6	4.6.1
3.5.5	4.6.5		

4.6 Tests.

4.6.1 Examination. The hose shall be examined to determine that the materials, interface, end cover, outer covering, weight, identification, and interchangeability conform to this specification.

4.6.2 Odor. Oxygen shall be flowed through the hose at 10 liters per minute for 2 minutes and then the hose shall be tested for odor in accordance with SAE-AS1065.

4.6.3 Cleanliness. All surfaces shall be free of visible particulates (50 microns and larger), free of visible fluorinated lubricants, and free of hydrocarbon contamination to a level not greater than 3 mg/ft² (see 6.5). Cleanliness of the surfaces shall be demonstrated by industrially accepted methods and these cleaning and verification methods shall be identified (see 6.2 and 6.5).

4.6.4 Flexibility. The hose shall be coiled and uncoiled around a 1.75 inch diameter rod 4 times. After each coiling and uncoiling cycle, the hose shall be twisted 90° (in the same direction each time) about its longitudinal axis. After the 4 coiling cycles, one end of the hose shall be fixed, the other end shall be twisted 360° in each direction 5 times. The test shall then be repeated by twisting the opposite hose end. For hoses 30 inches or longer, the hose end shall be twisted 720° in each direction 5 time. The hose shall then be subjected to the delamination and leakage tests.

MIL-PRF-87961B

4.6.5 Delamination. With one end of the hose capped, a vacuum equivalent to 16 inches of mercury shall be applied to the hose for 10 minutes. After this period and while the vacuum is maintained, the inner layer of the hose shall show no evidence of delamination (see 6.8).

4.6.6 Elongation. The hose shall be suspended vertically by one end and a 10 pound load shall be applied for 30 seconds. The hose elongation shall be between 3% and 10% of the original length. Two minutes after removal of the load, the hose shall have no permanent set in excess of 5% of the original length.

4.6.7 Leakage. The hose shall be pressurized to 10 psig for 1 minute and then the pressure shall be maintained at 5 psig for 5 minutes. During this time, the hose shall not leak in excess of 0.25 cm³ per minute per foot of hose.

4.6.8 Tensile load. With a MS22058 connector attached to one end of the hose assembly with a NAS397 clamp, a tensile load of 40 pounds shall be applied to the other end cover for 1 minute. The hose, end cover, or MS22058 connector shall not separate.

4.6.9 Static load. A static load of 125 pounds shall be applied for 30 seconds to a 4 inch section of the reinforced portion of the hose, and this load shall be normal to the longitudinal axis. With the load applied, the outside diameter shall not be reduced more than 15 percent. Two minutes after the load is removed, the permanent set of the outside diameter shall be no more than 5 percent.

4.6.10 High temperature. The hose shall be exposed to 160° ±5°F for 48 hours. While at 160°F, the hose shall be subjected to the flexibility test. After returning to room temperature, the hose shall be subjected to the odor, delamination, elongation, and leakage tests.

4.6.11 Low temperature. The hose shall be exposed to -40° ±5°F for 30 minutes, and then subjected to 5 cycles of the flexibility endurance test. After returning to room temperature, the hose shall be subjected to delamination, and leakage tests.

4.6.12 Abrasion test. Two samples of the reinforced section of the hose shall be subjected to the test in FED-STD-191, Method 5308, dry conditions. The abradant shall conform to PIA-C-419, Type I, hard texture duck No. 10. A minimum 1 pound load shall be maintained between the abradant and hose throughout the test. The reinforced section of the hose shall be subjected to 10,000 horizontal motions along the longitudinal hose axis without exposing the hose reinforcement.

4.6.13 Flexibility endurance. The hose shall be subjected to 500 cycles of being coiled and released around a 1.75 inch diameter rod. Then with one end of the hose fixed, the other hose end shall be subjected to 500 cycles of being twisted 270° in both directions. The hose shall then be subjected to the delamination and leakage tests.

4.6.14 Burst pressure. The hose shall be subjected to an internal pressure of 20 psi for 5 minutes. The hose shall then be subjected to the flexibility, delamination, and leakage tests.

MIL-PRF-87961B

4.6.15 Age. The age of the hose shall be verified to be no more than 12 months from the cure date to the acceptance date in accordance with SAE-AS1933.

4.6.16 Ozone resistance test. Samples of elastomer and end cover materials shall be tested in accordance with ASTM-D1149 (see 6.3). The test samples shall be elongated 20%, placed in an ozone-free atmosphere for 24 hours, and then subjected to an ozone environment. The temperature shall be $100^{\circ} \pm 2^{\circ}\text{F}$, an ozone concentration of 120 ± 1 parts per million by volume, and the air velocity across the sample shall be at least 2 feet per second. The material shall be exposed to these conditions for 60 minutes. The test slabs shall be examined under 10X magnification for evidence of damage such as blooming, checking, or cracking.

5. PACKAGING

5.1 Packaging. For acquisition purposes, the packaging requirements shall be as specified in the contract or order (see 6.2). When packaging of materiel is to be performed by DoD or in-house contractor personnel, these personnel need to contact the responsible packaging activity to ascertain packaging requirements. Packaging requirements are maintained by the Inventory Control Point's packaging activities within the Military Service or Defense Agency, or within the military service's system commands. Packaging data retrieval is available from the managing Military Department's or Defense Agency's automated packaging files, CD-ROM products, or by contacting the responsible packaging activity.

6. NOTES

(This section contains information of a general or explanatory nature that may be helpful, but is not mandatory.)

6.1 Intended use. The hose assembly covered by this specification is for supplying breathing oxygen to aircrew members during the operation of aircraft. The hose assembly extends from the breathing regulator to the application connector. These hose assemblies are part of the Aircraft Life Support System..

6.2 Acquisition requirements. Acquisition documents should specify the following:

- a. Title, number, and date of this specification.
- b. Type and PIN (see 1.2 and 6.10).
- c. When the first article is required (see 3.1).
- d. Color of the end cover (see 3.4.1).
- e. Item identification (see 3.5.17 item a and c).
- f. The requirement for the vendor to identify proposed cleaning and verification methods (see 4.6.3).
- g. Packaging requirements (see 5.1).
- h. Data required.

6.3 Materials. Previously, material certification sheets were used to validate the contractor's material selection.

MIL-PRF-87961B

6.4 Construction. Previous versions utilized 0.072 inch diameter aluminum wire, conforming to ASTM-B21 and SAE-AMS-QQ-A-225, left hand helical wound to 0.170 to 0.185 pitch. The inner layer had polyethylene (0.003 inch) tightly wrapped over itself to form 6 plies. The vinyl outer layer (0.005 inch) was tightly wrapped over itself to form 2 plies.

6.5 Cleaning. See MIL-STD-1330 and SAE-ARP1176 for guidance on proven cleaning methods and verifications. Visible inspections are typically conducted using white light and ultraviolet light to detect particulates and some types of hydrocarbons. The non-volatile residue test in SAE-ARP1176 may be used to baseline the hydrocarbon verification at an acceptable contamination level, however, other cleaning and verification methods that do not contain class I and II ODC solvents should be used for production. Previously, hoses were 75% filled with 160°F distilled water and both ends sealed. After being shaken for a minimum of 2 minutes, the water was poured into a clean glass container. The solution was not allowed to be more turbid than a standard suspension of 5 milligrams of diatomaceous silica in 10 millimeters of distilled water.

6.6 Abrasion testing. Previous procurements used a United States Testing Company model 8675 abrasion tester with 4 hose test specimens 6.5 inches long. The 4 sections of hose were obtained by cutting through the hose perpendicular to its longitudinal axis.

6.7 Sampling inspection. In previous acquisitions, hose offered for delivery at one time were considered a lot, and random samples were selected from each lot in accordance with inspection level S-2 in accordance with MIL-STD-1916.

6.8 Delamination testing. Previously, the delamination test used an end cap with a viewing window at one end and a vacuum source with a light at the other end. While under a vacuum, the interior of the hose was examined for evidence of delamination. A test stand equivalent to MS22057 was used.

6.9 Definitions.

a. Burst pressure. The burst pressure is the greatest applied internal pressure to which the hose can be subjected to before ultimate strength is exceeded.

b. Health hazards. Materials such as cadmium, lead, and polyvinyl chloride can be susceptible to outgassing in the presence of pure oxygen and at elevated temperatures. Outgassing by these and many other materials when used in breathing oxygen equipment can cause potential health hazards.

c. Hose and hose assembly. The hose consists of the basic hose, integral reinforcement, end covers and outer covering. The hose assembly may have MS22058 connectors with MS 22064 clamps and retainer straps. Previous hoses used outer coverings made from tubular polyamide or polyester material of knitted or braided construction.

d. Permanent set. A permanent change in the physical shape of the hose after all forces have been removed.

MIL-PRF-87961B

6.10 Part or identifying number (PIN). The PIN to be used for the hoses acquired to this specification are created as follows (see figures 1 through 5 and table II).

<u>M</u>	<u>87961</u>	<u>-X</u>	<u>-XX</u>
Prefix for military specification	Specification number	Dash number, hose type	Dash number, hose length (inches)

TABLE II Cross reference

Hose type	New PIN (note)	Old PIN (note)
Type I	M87961-1-XX	M87961/1-XX
Type II	M87961-2-XX	M87961/2-XX
Type III	M87961-3-XX	M87961/3-XX
Note: -XX indicates hose length in inches		

6.11 Supersession data. For supersession data see table III.

TABLE III. Supersession data

Superseding	Superseded
MIL-PRF-87961	MIL-H-87961
MIL-H-87961	MIL-H-87961/1
MIL-H-87961	MIL-H-87961/2
MIL-H-87961	MIL-H-87961/3

6.12 Subject term (key word) listing.

Aircraft life support

6.13 Changes from previous issue. Marginal notations are not used in this revision to identify changes with respect to the previous issue due to the extent of the changes.

MIL-PRF-87961B

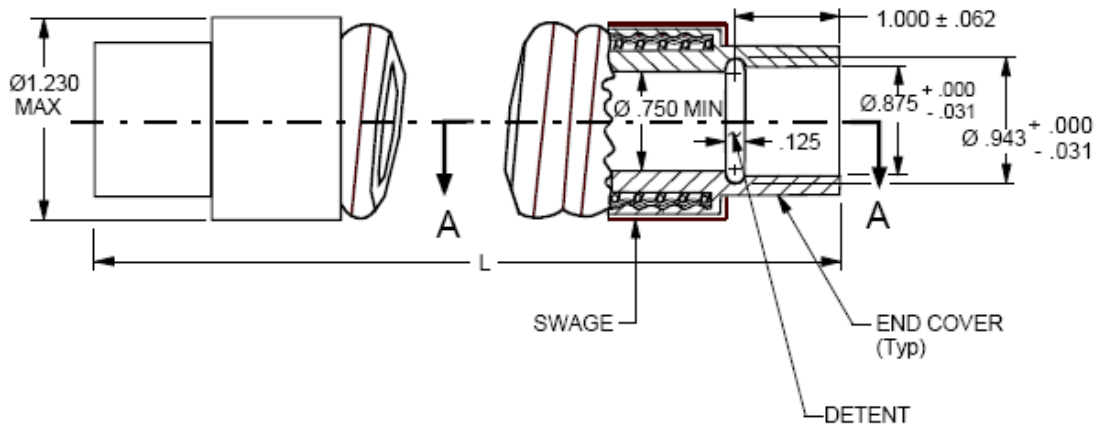

Part number M78961-1 dash number (note 3)	Length (inches)	Tolerances (% of length)
-8	8	-0, +15
-12	12	-0, +15
-13	13	-0, +15
-15	15	-0, +10
-18	18	-0, +10
-24	24	-0, +10
-30	30	-0, +10
-36	36	-0, +10
-42	42	-0, +10
-48	48	-0, +10
-54	54	-0, +10
-72	72	-0, +8
-96	96	-0, +8

Notes:

1. Dimensions are in inches. Tolerances are as specified
2. End dimensions and notes apply to each end.
3. Dash number indicates length.
4. Drawing not scale.

FIGURE 1. Type I hose.

MIL-PRF-87961B

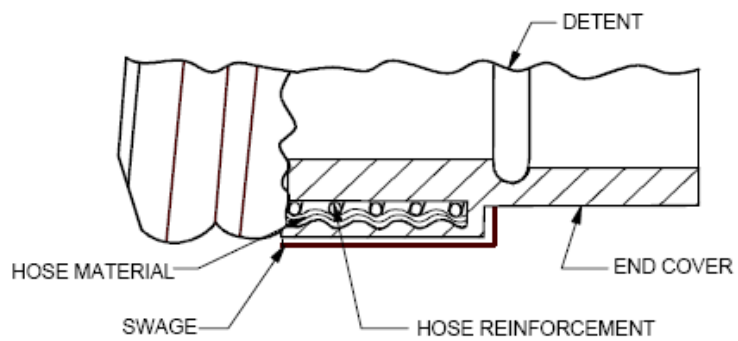

SECTION A-A

Notes:

1. Drawing not to scale.

FIGURE 2. Type I hose end – Section A-A.

MIL-PRF-87961B

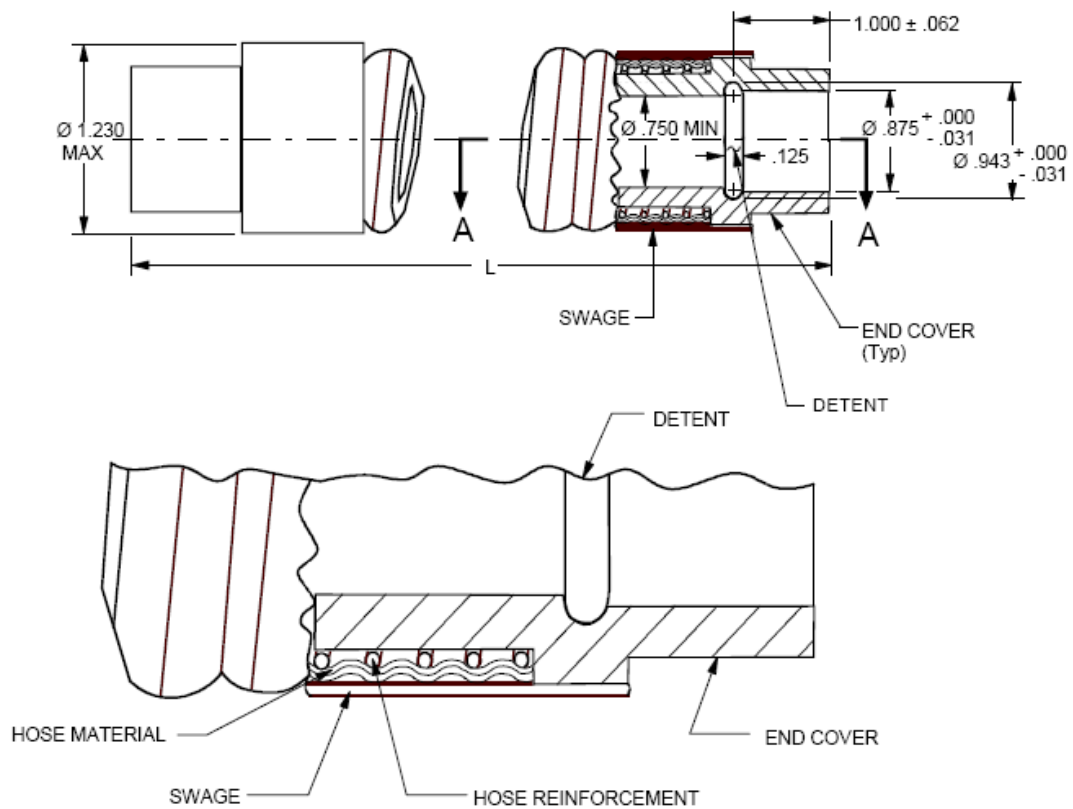

Notes:

1. Dimensions are in inches. Tolerances are as specified.
2. End Dimensions and notes apply to each end.
3. Dash number indicates length.
4. Drawing not to scale.

FIGURE 3. Type I hose (alternate configuration).

MIL-PRF-87961B

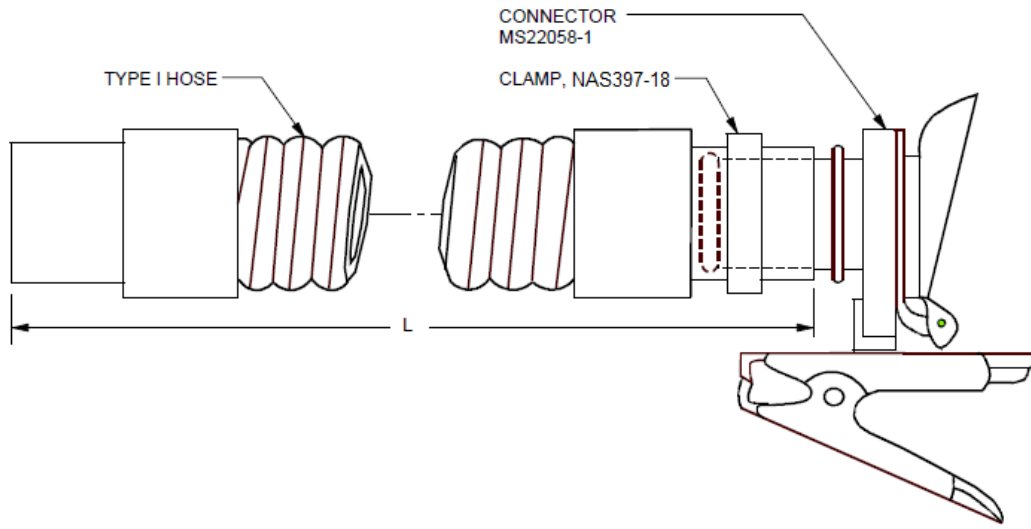

Part number M78961-2 dash number (note 1)	Length (inches)	Tolerances (% of length)
-30	30	-0, +10
-36	36	-0, +10
-42	42	-0, +10
-48	48	-0, +10
-54	54	-0, +10
-72	72	-0, +8
-96	96	-0, +8

Notes:

1. Dash number indicates.
2. Drawing not scale.

FIGURE 4. Type II hose assembly.

MIL-PRF-87961B

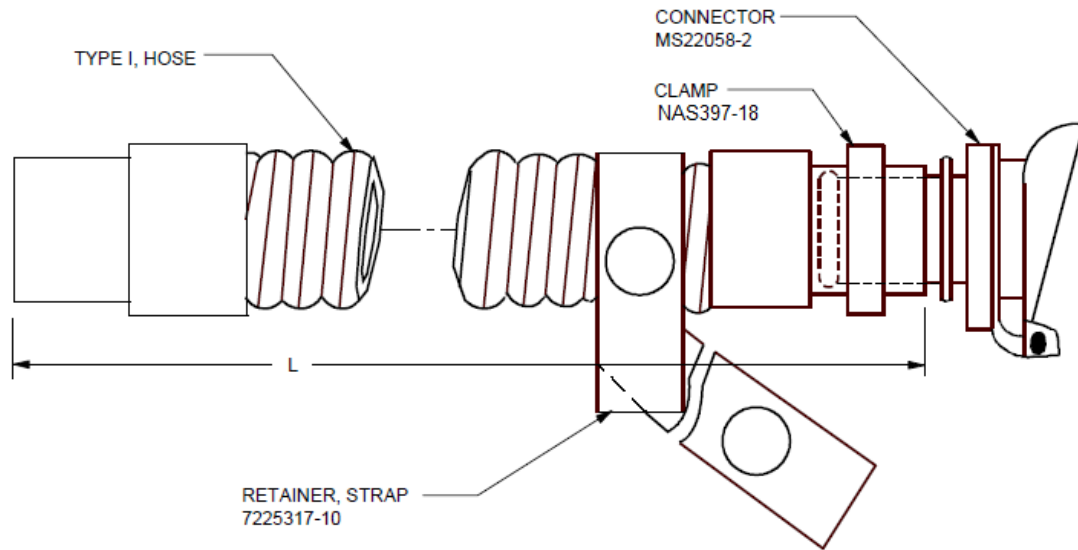

Part number M78961-3 dash number (note 1)	Length (inches)	Tolerances (% of length)
-12	12	-0, +15
-18	18	-0, +10
-24	24	-0, +10
-30	30	-0, +10
-36	36	-0, +10
-42	42	-0, +10
-48	48	-0, +10
-54	54	-0, +10
-72	72	-0, +8
-96	96	-0, +8

Notes:

1. Dash number indicates length.
2. Drawing not to scale.

FIGURE 5. Type III hose assembly.

MIL-PRF-87961B

Custodians:
Air Force - 71

Preparing Activity:
Air Force – 71

(Project 4720-2013-012)

Review Activities:
Air Force – 99
DLA- CC

NOTE: The activities listed above were interested in this document as of the date of this document. Since organizations and responsibilities can change, you should verify the currency of the information above using the ASSIST Online database at <https://assist.dla.mil/>.