

INCH-POUND

MIL-PRF-87930A (USAF)
24 November 1997

Superseding
MIL-P-87930 (USAF)
25 October 1977

PERFORMANCE SPECIFICATION

PROPELLANT, HYDRAZINE-WATER
(70% HYDRAZINE - 30% WATER)

This specification is approved for use by all
Departments and Agencies of the Department of Defense

1. SCOPE

1.1 Scope. This specification covers the requirements for a hydrazine-water propellant blend, 70 percent by weight hydrazine and 30 percent by weight water.

2. APPLICABLE DOCUMENTS

2.1 General. The documents listed in this section are specified in sections 3 and 4 of this specification. This section does not include documents in other sections of this specification or recommended for additional information or as examples. While every effort has been made to ensure the completeness of this list, document users are cautioned that they must meet all specified requirements documents cited in sections 3 and 4 of this specification, whether or not they are listed.

2.2 Government documents.

2.2.1 Specifications, standards, and handbooks. The following specifications form a part of this document to the extent specified herein. Unless otherwise specified, the issues of these documents are those listed in the issue of the Department of Defense Index of Specifications and Standards (DoDISS) and supplement thereto, cited in the solicitation (see 6.2).

SPECIFICATIONS

DEPARTMENT OF DEFENSE

Beneficial comments (recommendations, additions, deletions) and any pertinent data which may be of use in improving this document should be addressed to: Code (68) SA-ALC/SFSP, 1014 Billy Mitchell Blvd/STE 1, Kelly AFB TX 78241-5603, by using the standardization Document Improvement Proposal (DD Form 1426) appearing at the end of this document or by letter.

AMSC N/A

FSC 9135

DISTRIBUTION STATEMENT A. Approved for public release; distribution is unlimited.

MIL-PRF-87930A

- MIL-PRF-25604 - Propellant, uns-Dimethylhydrazine
- MIL-PRF-26536 - Propellant, Hydrazine
- MIL-PRF-27401 - Propellant Pressurizing Agent, Nitrogen
- MIL-PRF-27404 - Propellant, Monomethylhydrazine
- MIL-PRF-27407 - Propellant Pressurizing Agent, Helium

(Unless otherwise indicated, copies of the above specifications, and standards are available from the Standardization Document Order Desk, 700 Robbins Avenue, Building 4D, Philadelphia PA 19111-5094).

2.3 Non-Government publications. The following documents form a part of this document to the extent specified herein. Unless otherwise specified, the issues of the documents which are DoD adopted are those listed in the issue of the DoDISS cited in the solicitation. Unless otherwise specified, the issues of documents not listed in the DoDISS are the issues of the documents cited in the solicitation (see 6.2).

AMERICAN SOCIETY FOR TESTING AND MATERIALS (ASTM)

- ASTM D 1068 - Tests for Iron in Water (DoD adopted)
- ASTM D 1193 - Specification for Reagent Water (DoD adopted)
- ASTM D 2276 - Test Method for Particulate Contaminant in Aviation Fuel by Line Sampling (DoD adopted)
- ASTM E 29 - Practice for Using Significant Digits in Test Data to Determine Conformance with Specifications (DoD adopted)

(Application for copies should be addressed to the American Society for Testing and Materials, 100 Barr Harbor Drive, West Conshohocken, PA 19428-2959).

2.4 Order of precedence. In the event of a conflict between the text of this document and the references cited herein, the text of this document takes precedence. Nothing in this document, however, supersedes applicable laws and regulations unless a specific exemption has been obtained.

3. REQUIREMENTS

3.1 Chemical and physical properties. The chemical and physical properties of the propellant shall conform to those listed in Table I when tested in accordance with the applicable test methods.

3.2 Limiting values. The following applies to all specified limits in this specification: For purposes of determining conformance with these requirements, an observed value or a calculated value shall be rounded off "to the nearest unit" in the last right-hand digit used in expressing the specification limit according to the rounding-off method of ASTM Practice E 29 for using Significant Digits in Test Data to Determine Conformance with Specifications.

MIL-PRF-87930A

3.3 Filter. A filter with a 2-micrometer nominal and 10-micrometer absolute rating shall be installed between the manufacturer's plant system and the container to be filled for delivery.

3.4 Qualitative. The propellant shall be colorless, homogeneous liquid when examined visually by transmitted light.

TABLE I. Chemical and physical properties.

PROPERTIES	LIMITS	TEST PARAGRAPH
Hydrazine (% by weight)	69 - 70	4.3.2
Water (% by weight)	30 min	4.3.2
Particulate (mg/L)	1.0 max	4.3.3
Chloride (% by weight)	0.0005 max	4.3.4
Aniline (% by weight)	0.40 max	4.3.5
Iron (% by weight)	0.002 max	4.3.6
Nonvolatile residue (% by weight)	0.004 max	4.3.7
Carbon dioxide (% by weight)	0.002 max	4.3.8
Other volatile carbonaceous material (Total as either MMH or UDMH/Alcohol, % by weight)	0.02 max	4.3.9

4. VERIFICATION

4.1 Classification of inspections. The inspections shall be classified as quality conformance inspections.

4.2 Quality conformance inspection. Unless otherwise specified (6.2), each filled shipping container shall be considered a lot and shall be sampled. Each sample shall be subjected to the visual examination described in 4.3.1 for conformance to 3.4 and to the tests described in Table I for conformance to the requirements specified in Table I.

4.2.1 Sample. A sample consists of not less than 1500 mL of propellant. Unless otherwise specified, quality conformance tests shall be made on the sample of propellant taken directly from the shipping container. When required, the sample shall be forwarded to a laboratory designated by the procuring activity for subjection to the quality conformance tests specified herein. The bottles intended for sampling shall be specially cleaned and handled according to the procedure described in ASTM D2276 with the following addition: the bottle must be dried with filtered nitrogen after cleaning. The sampling of drums and other shipping containers shall be conducted in such a manner that neither the contents of the container nor the sample is exposed to the atmosphere. The use of a plastic bag purged with nitrogen to cover the container is mandatory.

MIL-PRF-87930A

4.2.2 Rejection. When any sample of the propellant tested in accordance with 4.3 fails to conform to the requirements specified herein, the entire lot represented by the sample shall be rejected.

4.3 Test methods.

4.3.1 Examination of product. The propellant shall be visually examined while performing test specified in 4.3.3 to determine compliance with the requirement as specified in 3.4.

4.3.2 Hydrazine assay and water. The propellant and water content of the sample shall be determined by the following method.

4.3.2.1 Gas chromatographic method.

4.3.2.1.1 Suggested column preparation. Weigh 2 grams of polyethylene glycol 400 and 18 grams of 60/80 mesh Fluoropak support material into separate beakers. Dissolve the polyethylene glycol 400 in reagent grade methylene chloride (dichloromethane). The final volume of the solution should be approximately that of the support material. Pour the support material into the polyethylene glycol 400 (stationary phase) solution with gentle stirring. Evaporate the solvent by spreading the mixture in a tray. Occasionally turn the mixture gently during the drying process. The column packing material is dry when it becomes a free-flowing powder. Fill a 1/8 inch x 2 foot stainless steel tube by pouring the prepared material through a small funnel attached to one end. The bottom of the tubing is plugged with a small wad of glass wool or capped. Use a mechanical vibrator to facilitate packing. When the column is full, plug the ends with glass wool and bend the tubing to the configuration required by the chromatograph oven.

4.3.2.1.2 Procedure. Install the prepared column into the gas chromatograph but do not connect the column to the detector inlet. Condition the column for at least 4 hours by heating at 100°C with the carrier gas (helium) flow set at approximately 20 milliliters per minute. After conditioning the column, set the column oven temperature at 100°C and connect the column to the detector inlet. Adjust the carrier gas flow to 20-50 milliliters per minute. If the gas chromatograph is equipped with separate injector and detector temperature controls, set the detector at 150°C and the injector at 110°C. Saturate the column by injecting two or three 5-microliter samples of propellant. Saturate the column prior to each series of analyses. When more than 30 minutes elapse between the elution of the hydrazine and the injection of a new sample, resaturate the column with one 5-microliter injection of propellant sample. Use a clean, dry 10-microliter hypodermic syringe and draw up 8 microliters of sample. Invert or pump the syringe to expel the gas bubbles. Carefully set the syringe plunger to the 1-microliter mark and wipe the tip with a piece of tissue without touching the open end of the needle. Quickly inject the sample into the instrument injection port and then withdraw the syringe immediately. Measure the areas of all peaks in the chromatogram. The analyst may vary the temperature, flow rate, column size, and sample size to optimize the analysis.

4.3.2.1.3 Calculations.

$$\%N_2H_4 = \frac{A_H K_H \times 100}{\sum A_i K_i \left(\frac{100}{100 - \%Aniline} \right)}$$

MIL-PRF-87930A

$$\%H_2O = \frac{A_w K_w \times 100}{\sum A_i K_i \left(\frac{100}{100 - \%Aniline} \right)}$$

$$\%NH_3 = \frac{A_A K_A \times 100}{\sum A_i K_i \left(\frac{100}{100 - \%Aniline} \right)}$$

where: $A_H K_H$, $A_w K_w$, $A_A K_A$ equals the areas of the hydrazine, water, and ammonia peaks multiplied by their respective sensitivity factors.

$$\sum A_i K_i \left(\frac{100}{100 - \%Aniline} \right)$$

The above expression equals the sum of area/sensitivity factor products of all peaks in the chromatogram corrected for the aniline content of the propellant.

NOTE: Assume $K_H = K_A = 1.000$

4.3.2.1.4 Calibration. Determine the hydrazine and water content of a sample of anhydrous hydrazine using the procedure described in 4.3.2.1.2. and calculate the results as shown in 4.3.2.1.3. Assume $K_H = K_w = K_A = 1.000$. Using at least 10 grams of this analyzed hydrazine, prepare a mixture with distilled water which is approximately 70% hydrazine and 30% water. Use an analytical balance that is accurate to at least ± 1 milligram. Calculate actual composition of the mixture as follows:

$$\%N_2H_4 = \frac{\text{weight } N_2H_4 \times \%N_2H_4(\text{assay})}{\text{total weight}}$$

$$\%H_2O = \frac{\text{weight } H_2O + \left(\frac{\text{weight } N_2H_4 \times \%H_2O(\text{assay})}{100} \right)}{\text{total weight}} \times 100$$

where: $\%N_2H_4(\text{assay})$, $\%H_2O(\text{assay})$ equals the hydrazine and water content of the anhydrous hydrazine used.

The weight of N_2H_4 and the weight of H_2O equals the weights of anhydrous hydrazine and water to prepare the mixture. The total weight equals the weight of N_2H_4 plus the weight of H_2O .

$$K_w = \frac{A_H \%H_2O}{A_w \%N_2H_4}$$

MIL-PRF-87930A

Use K_w as determined above in 4.3.2.1.3 for the propellant sample.

4.3.2.1.5 Equipment and reagents. The following equipment and reagents shall apply as test conditions of 4.3.2.

a. Equipment:

- (1) Gas chromatograph - incorporating a thermal conductivity detector.
- (2) Recorder - potentiometric strip chart, 0 - 1 millivolt, 1 second full scale response, with integrator.
- (3) Tubing: stainless steel, 1/8 inch OD x 2 feet.
- (4) Syringe: 10 microliter capacity

b. Reagents:

- (1) Dichloromethane: ACS Grade.
- (2) Polyethylene glycol 400: Carbowax 400 or equivalent.
- (3) Fluoropak 80: 60/80 mesh, Analabs, Inc.; 9 Hobson Avenue; Hamden, Ct 06518, or equivalent.
- (4) Hydrazine: anhydrous conforming to MIL-P-26536.
- (5) Helium: conforming to MIL-P-27407.

4.3.3 Particulate. The propellant sample shall be tested for contamination in accordance with ASTM D-2276, Method A, with the following exceptions:

4.3.3.1 Mix the sample thoroughly without exposure to air. Immediately pour 1000 mL of the sample into a clean 1000 mL graduated cylinder. Use this 1000 mL of propellant for the particulate analysis.

4.3.3.2 Use a solvent resistant filter disc made from such materials as Millipore, FALP-04700 or Gelman VF-6, Fluoride-Metricel), plain, white, 10 ± 3 microns, 47 mm diameter, or equivalent, instead of that specified in ASTM D-2276.

4.3.3.3 The drying oven temperature shall be 158°F (70°C) instead of the 194°F (90°C) specified in ASTM D-2276.

4.3.3.4 Filtered isopropyl alcohol shall be used for rinsing the sample bottle and filter holder instead of petroleum ether specified in ASTM D-2276. Wet the filter with filtered isopropyl alcohol prior to filtering the sample.

4.3.4 Chloride. The chloride level shall be determined by methods based on accepted scientific (chemical) principles, such as colorimetric with mercury thiocyanate, combinations of silver nitrate and/or specific ion electrodes (Ag^+/Cl^-), or ion chromatographic techniques. In case of dispute 4.3.4.1 shall be the referee method.

MIL-PRF-87930A

4.3.4.1 Procedure. Rinse the propellant residue container in one vessel from 4.3.7 with a 5 mL portion of 1N H₂SO₄. Briefly stir and heat the liquid to boiling but do not allow the condensate to escape. Transfer the solution to a 25 mL volumetric flask. Rinse vessel with a second 5 mL portion of acid followed by one 5 mL portion of distilled water. Combine the portions in the 25 mL volumetric flask and add two to three drops of bromcresol green indicator. Dropwise titrate the contents of the flask to a green endpoint with 1N NaOH and then dilute to the mark with distilled water. Mix the solution and transfer approximately 10 mL to a 25 mL beaker. Immerse the electrodes in the sample solution and record the millivolt reading. Compare the millivolt reading from the sample to a calibration curve prepared from chloride standards and record the chloride concentration of the sample.

4.3.4.2 Calibration. Weigh exactly 2.103 grams of potassium chloride (KCl) and transfer to a 1000 mL volumetric flask. Dissolve the salt in distilled water and dilute to the mark. Mix the solution thoroughly and transfer to a 1000 mL plastic bottle. This solution contains 1000 ppm Cl⁻. To each of four 1000 mL volumetric flasks add 400 mL of 0.1N H₂SO₄ solution. Prepare dilute chloride standards by pipeting 5.00, 10.0, 25.0, and 50.0 mL of the 1000 ppm chloride standard sequentially into the four flasks. Add 2-3 drops of the bromcresol green indicator to each flask and titrate with 1N NaOH to the green endpoint. Dilute each to the mark with distilled water, mix thoroughly and transfer the standards to 1000 mL plastic bottles. The chloride levels of these standards are 5, 10, 25, and 50 ppm, respectively. Pour approximately 10 mL of each standard into one of four 25 mL beakers and starting with the 5 ppm chloride solution. Immerse the electrodes and record the resulting millivolt reading. Rinse the electrode with distilled water and wipe with a clean tissue between each standard and each sample.

4.3.4.3 Calculation. Calculate the percent chloride in the sample using the following formula:

$$\%Cl^{-} = \frac{\text{ppm}Cl^{-}(\text{from curve}) \times 25}{1.03 \times 10^6}$$

4.3.4.4 Reagents and equipment. The following shall apply as test conditions of 4.3.4:

4.3.4.4.1 Reagents.

a. Chloride-free distilled water; the water is considered chloride-free if a 100 mL sample used to dissolve 0.1 g of silver nitrate, shows no turbidity after standing in the dark for 24 hours.

b. 0.1N H₂SO₄; prepare by pouring 3 mL of ACS grade concentrated H₂SO₄ into 300 mL of chloride-free water contained in a 1000 mL volumetric flask. Cool the solution to room temperature, dilute to the mark with the chloride-free distilled water, and mix thoroughly. Transfer the solution to a plastic bottle.

c. 1N NaOH; prepare by dissolving 40 g of ACS grade, low carbonate, NaOH in 300 mL of chloride-free water contained in a 1000 mL volumetric flask. Cool the solution to room temperature, dilute to the mark with the chloride-

MIL-PRF-87930A

free distilled water, and mix thoroughly. Transfer the solution to a plastic bottle and protect from prolonged exposure to the atmosphere.

- d. Potassium chloride - KCl, ACS grade, dried for 4 hours at 100°C.
- e. Bromocresol green indicator - 1% aqueous solution. Use chloride-free distilled water.
- f. Silver nitrate - ACS grade.

4.3.4.4.2 Equipment.

- a. Chloride electrode - solid state Orion Model 94-17, or equivalent.
- b. Reference electrode, double junction, Orion Model 90-02 with 1M KNO₃ outer compartment filling solution, or equivalent.
- c. pH/millivolt meter - Orion Ion Analyzer Model 801, or equivalent.
- d. Analytical balance - 100 g capacity, 0.1 mg sensitivity.
- e. Volumetric flasks - 1000 mL and 25 mL capacity.
- f. Volumetric pipets - 5.00, 10.0, 25.0 and 50.0 mL capacity.
- g. Eye droppers
- h. Beakers - 25 mL capacity, plastic, disposable.
- i. Bottles - 1000 mL capacity, plastic, narrow mouth screw cap.

4.3.5 Aniline. The aniline content of the propellant shall be determined by one of these methods. The method in 4.3.5.1 is the referee method.

4.3.5.1 Spectrophotometric method.

4.3.5.1.1 Procedure. Pipet or syringe 0.25 mL (250 µL) of propellant into a 25 mL volumetric flask containing approximately 15 mL of distilled water, dilute to the mark with distilled water, and mix the solution thoroughly. Fill two 1 cm pathlength silica spectrophotometer cells with distilled water and place one in each position for sample and reference cells. Using the appropriate source and detector for the spectrophotometer set the recorder pen to zero absorbance at 320 nm and scan the region between 320 nm and 240 nm. If the baseline is relatively flat then the cells and distilled water can be considered free from interfering substances. Exchange the water in the sample cell with the previously prepared sample, using several rinses with sample solution, and rescan the 320 nm to 240 nm region, first ensuring that the recorder pen is set at zero absorbance at 320 nm. Draw a baseline under the aniline peak at 280 nm, measure, and record the net absorbance of the peak. Determine the aniline content of the sample by comparing the net absorbance obtained to a calibration curve of net absorbance versus percent aniline.

4.3.5.1.2 Calibration. Pipet or syringe 0.025 mL (25 µL) of aniline into a 100 mL volumetric flask containing 50 mL of distilled water. Shake the

MIL-PRF-87930A

mixture to dissolve the aniline and dilute the solution to the mark with distilled water. Mix the standard thoroughly. Transfer to separate 25 mL volumetric flasks the following volumes of the previously prepared aniline standard; 2.0 mL, 4.0 mL, 6.0 mL, and 8.0 mL. Dilute each to the mark with distilled water and mix thoroughly. The aniline concentrations are equivalent to 0.2, 0.4, 0.6, and 0.8% aniline in propellant (as diluted). Determine the net absorbance of standards versus distilled water in the same manner as with the sample. Plot net absorbance versus percent aniline and draw a curve through the points. All calibration standards should be prepared fresh daily.

4.3.5.1.3 Reagents and Equipment. The following shall apply as test conditions of 4.3.5.1.

4.3.5.1.3.1 Reagents.

- a. Distilled water
- b. Aniline, ACS grade

4.3.5.1.3.2 Equipment.

- a. Spectrophotometer, double beam, ultra violet, narrow band width, recording, equipped with 1 cm silica cells, Cary 14 or equivalent.
- b. Syringes - 0.05 mL (50 μ L) and 0.5 mL (500 μ L) capacities.
- c. Pipets - volumetric, 2.0, 4.0, 6.0, and 8.0 mL capacities or one 10 mL syringe graduated in 0.2 mL increments.
- d. Volumetric flasks - 100 mL and 25 mL capacities.

4.3.5.2 Gas chromatographic method.

4.3.5.2.1 Procedure. Prepare a column as described in 4.3.2 except substitute a mixture consisting of 0.5 grams of Amine 220 and 9.5 grams of Apiezon L for the propylene glycol 400. Also use a white, silanized 60/80 mesh diatomaceous earth support instead of Anakrom B. Condition the column for 4 hours at 150°C prior to connection to the detector. Use a gas chromatograph equipped with a flame ionization detector. The inlet, if separately heated, should be adjusted to 130° or greater. The column and detector temperatures should be 130°C and 150°C, respectively. After the instrument has stabilized, inject 0.5 μ L of propellant and record the area of the aniline peak. Compare the area of the aniline peak with that of a calibration standard and calculate the percent aniline of the sample.

4.3.5.2.2 Calibration. Pipet or syringe 0.5 mL (500 μ L) of aniline into a 100 mL volumetric flask containing approximately 50 mL of distilled water, shake the mixture, dilute to the mark with distilled water, and mix the solution thoroughly. This calibration standard is equivalent to 0.5% aniline in propellant. Inject 0.5 μ L of the standard into the inlet of the chromatograph and record the area of the aniline peak. Prepare the standard fresh daily.

MIL-PRF-87930A

4.3.5.2.3 Calculation. Use the following formula for calculation of the aniline content of the propellant:

$$\% \text{aniline} = \frac{0.5A_s}{A_c}$$

where:

A_s = Area of the sample aniline peak times its attenuation factor.

A_c = Area of the standard aniline peak times its attenuation factor.

4.3.5.2.4 Reagents and equipment. The following reagents and equipment shall apply as test conditions of 4.3.5.2.

4.3.5.2.4.1 Reagents.

- a. Aniline - ACS grade
- b. Distilled water

4.3.5.2.4.2 Equipment.

- a. Volumetric flask - 100 mL capacity
- b. Syringe - 1.0 μ L capacity
- c. Gas chromatograph, equipped with a flame ionization detector.
- d. Recorder, potentiometric, with integrator, pen speed = 1 sec FS, 1 mv span.
- e. Pipet - 0.5 mL capacity or syringe 0.5 mL (500 μ L) capacity

4.3.6 Iron. The iron content of the propellant shall be determined by one of the following methods. The method of 4.3.6.1 is the referee method.

4.3.6.1 Atomic absorption.

4.3.6.1.1 Procedure. Rinse the propellant residue contained in one vessel from 4.3.7 as follows: Add 5 mL of 5N H₂SO₄ to the vessel and place on a hotplate stirrer. Heat the mixture, while stirring, to boiling and maintain at that temperature for three to five minutes. Allow the solution to cool and transfer to a 200 mL volumetric flask. Rinse the vessel at least three times with 5 mL portions of 0.1N H₂SO₄ combining all of the rinses in the volumetric flask. Dilute to the mark with distilled water and mix thoroughly. Determine the absorbance of the sample at an iron wavelength closest to 2480 Å on a suitable atomic absorption spectrophotometer, after setting the instrument to zero absorbance, with 0.1N H₂SO₄. Compare the results to a calibration curve prepared from iron standards and record the iron-concentration of the sample.

4.3.6.1.2 Calibration. Prepare a 1000 ppm iron standard by dissolving 1.00 g of iron wire or shot in 50 mL of 6N H₂SO₄. Use heat. Quantitatively transfer the resulting solution to a 1000 mL volumetric flask with 0.1N H₂SO₄.

MIL-PRF-87930A

and dilute to the mark with 0.1N H₂SO₄. To four 200 mL volumetric flasks add successively 1.0, 2.0, 3.0, 5.0 mL of the iron standard, dilute each to the mark with 0.1N H₂SO₄, and mix thoroughly. The iron concentrations of these solutions are 5, 10, 15, and 25 ppm, respectively. (Commercial standard solutions may be used.) After setting the instrument to zero absorbance with 0.1 N H₂SO₄, determine the absorbance of the four calibration standards. Prepare a calibration curve of absorbance versus ppm iron.

4.3.6.1.3 Calculation. Calculate the iron content of the propellant using the following formula:

$$\%Fe = \frac{(ppmFe)}{1.03 \times 10^4}$$

where: ppm Fe = the iron content of the sample solution, using the calibration curve.

4.3.6.1.4 Reagents and Equipment. The following equipment shall apply as test conditions of 4.3.6.1.

4.3.6.1.4.1 Reagents.

- a. Iron - ACS grade, wire or shot.
- b. 5N H₂SO₄ - carefully pour 180 mL of concentrated ACS grade H₂SO₄ into 600 mL of distilled water contained in a 1000 ml volumetric flask. Cool the solution, dilute to the mark with distilled water, and mix thoroughly.
- c. 0.1N H₂SO₄ - prepare as above except use 3 mL of concentrated ACS grade H₂SO₄.

d. Distilled water

4.3.6.1.4.2 Equipment.

- a. Hotplate/stirrer - controllable heat and stir settings.
- b. Atomic absorption spectrophotometer, Perkin Elmer 290, 303 or equivalent with an iron hollow cathode lamp.
- c. Volumetric flasks - 1000 mL and 200mL capacities.
- d. Volumetric pipets - 1.0, 2.0, 3.0 and 5.0 mL capacities.

4.3.6.2 Colorimetric method.

4.3.6.2.1 Procedure. Prepare the sample solution in the same manner as described in 4.3.6.1. Analyze the solution using the method described by ASTM D 1068, Method A, paragraph 12.

4.3.7 Nonvolatile residue (NVR). The nonvolatile residue of the propellant shall be determined in duplicate by either of the following methods (4.3.7.1 shall be the referee method).

4.3.7.1 Dropwise method.

MIL-PRF-87930A

4.3.7.1.1 Procedure. Clean the unassembled apparatus with detergent and rinse thoroughly with distilled water. Dry the parts in an oven at 110°C. Assemble the apparatus as shown in Figure 1. Fill the water bath with distilled water and turn on the heater. Adjust the water level of the bath to approximately one-half inch below the lowest fitting and mark this level on the bath. When the bath temperature reaches boiling adjust the nitrogen purge to approximately 2 liters per minute and turn on the water aspirator. With the sample delivery valve closed, the pressure in the apparatus should be below 30 mm Hg. Open the sample delivery valve slowly to adjust the apparatus pressure to approximately 60 mm Hg. Allow the apparatus to purge for approximately five minutes to remove traces of water. Remove the water bath and dry the outside of the residue vessel with a clean lintless tissue. Disconnect the aspirator from the apparatus and remove the residue vessel using a tissue to hold the vessel. Wipe the outside of the vessel carefully and place it near the analytical balance. After at least twenty minutes, accurately weigh the residue vessel. Record the weight. Reassemble the apparatus and close the sample delivery valve. Replace the water bath, adjust the water level to the mark, heat the water to boiling. Transfer 100 mL of propellant to the apparatus using a syringe equipped with a polytetrafluoroethylene needle as shown. With the nitrogen purge in place, turn on the water aspirator and reduce the apparatus pressure to less than 30 mm Hg. Slowly open the sample delivery valve to admit propellant to the residue vessel and adjust the flow such that the apparatus pressure does not exceed 60 mm Hg (ca 2 drops per second). The quantity of propellant in the residue vessel should not exceed 2 to 4 mL at the equilibrium evaporation rate. Adjust the sample delivery valve to maintain the evaporation pressure at less than 60 mm Hg. After 100 mL of propellant has been evaporated (ca 30 minutes), allow the residue vessel to purge for an additional five minutes to insure complete evaporation of volatile material. Remove the water bath, disconnect the aspirator, wipe the outside of the residue vessel, and remove it from the apparatus. Allow the residue vessel to stand near the analytical balance for at least twenty minutes before weighing. Weigh the residue vessel. Record the weight. Clean the residue vessel by refluxing 5 mL of 5N H₂SO₄ in the vessel for several minutes followed by several rinses with distilled water. The vessel may be dried as described above or by gently heating the vessel with a burner while purging with dry nitrogen. Regardless of the drying method used, allow at least twenty minutes for the vessel to equilibrate to ambient temperature and humidity before weighing.

4.3.7.1.2 Calculations. Calculate the nonvolatile residue of the propellant as follows:

$$\%NVR = \frac{W_1 - W_0}{1.03}$$

Where: W_0 = Wt clean vessel
 W_1 = Wt residue and vessel

Report the averaged result of duplicate NVR determinations.

$$Average \%NVR = \frac{(\%NVR)_1 + (\%NVR)_2}{2}$$

4.3.7.1.3 Reagents and Equipment. The following reagents and equipment shall apply as test conditions of 4.3.7.

4.3.7.1.3.1 Reagents.

MIL-PRF-87930A

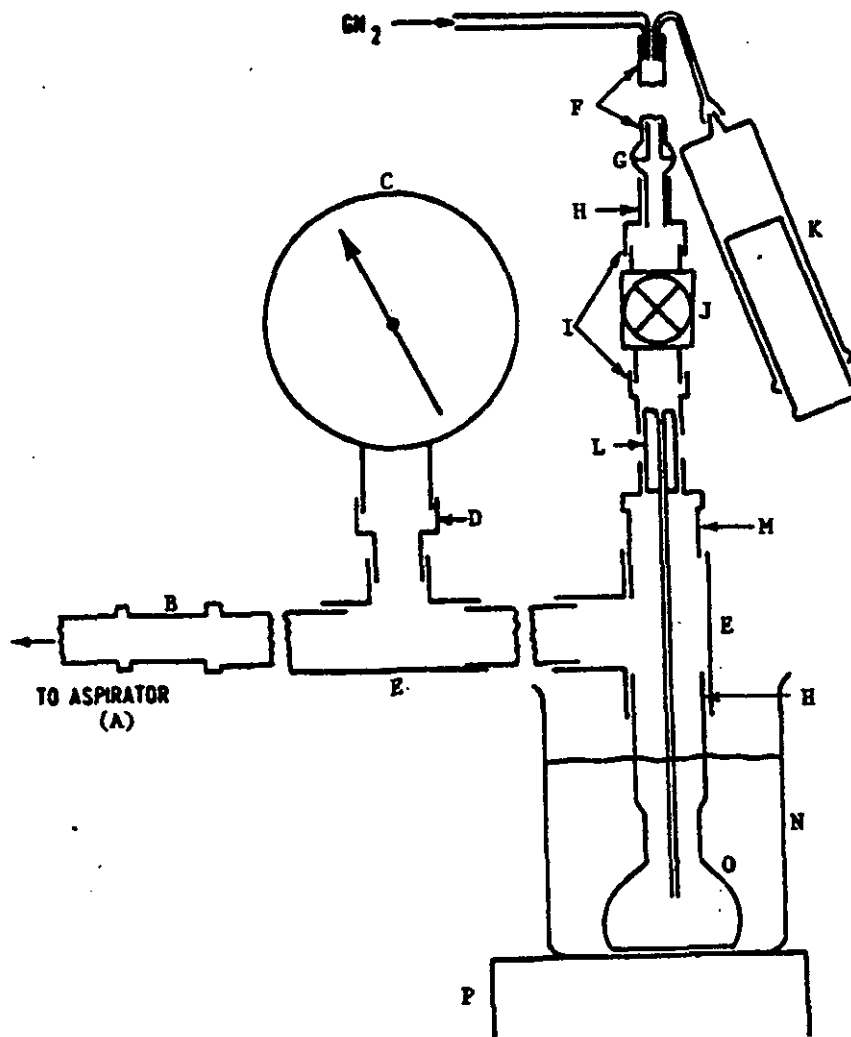

- | | |
|---|---|
| A - Water aspirator (glass or polyethylene) | J - Valve (stainless steel, polytetrafluoroethylene packing, Whitey Cat No 55, or equivalent) |
| B - Connector (polyethylene, separable, Sargent Cat No S-73788, or equivalent) | K - Syringe (glass, 100 mL capacity, with 8 - 12 in polytetrafluoroethylene needle) |
| C - Gauge (absolute pressure, 0 - 760 mm range, stainless steel, Matheson Gas Co model no 63-5601, or equivalent) | L - Rod (polytetrafluoroethylene or polyethylene, $\frac{1}{8}$ in OD drilled and a 1/16 OD \times 0.025 in wall tube inserted) |
| D - Adapter, SS-811-A4F | M - Reducer, SS-400-R-8 |
| E - Union Tee, SS-810-3 (2 each) | N - Beaker (glass, 1000 mL capacity) |
| F - Pipet (volumetric, borosilicate glass, 100 mL capacity) | O - Flask (volumetric, borosilicate glass, 25 mL capacity) |
| G - Joints (borosilicate glass, spherical, 12/5, ball, socket, and clamp) | P - Hotplate (adjustable heat range) |
| H - Ferrules, T-814-1, T-813-1, T-4-4-1, T-403-1 | |
| I - Connector, SS-400-7-2 (2 each) | |
- NOTE: All fittings, stainless steel, Swagelok or equivalent (D, E, H, I, M)

FIGURE 1. NVR Apparatus

MIL-PRF-87930A

- a. Distilled water
- b. Gaseous nitrogen - conforming to MIL-PRF-27401, or equivalent

4.3.7.1.3.2 Equipment. (See Figure 1.)

- a. Tubing - polyethylene, ½ inch OD, borosilicate glass, ½ inch OD.
- b. Clamps - hose, to fit ½ inch OD tube.

4.3.7.2 Rotary evaporation.

4.3.7.2.1 Procedure. Dry a 250 mL round bottom flask in an oven at 110°C for one hour. Allow flask to cool in a desiccator and weigh on the analytical balance. Repeat above procedure until weight remains constant to ± 2 mg. Transfer 100 mL of propellant into the tared 250 mL flask. Place the flask on the evaporator using a standard taper Teflon sleeve as a seal. Attach a water aspirator pump to the evaporator via a one-liter suction flask and evaporate the propellant to dryness. A warm bath may be placed around the rotating flask to aid evaporation.

WARNING

The contact of hydrazine vapor with metal surfaces, as in a metal rotary evaporator, must be avoided. Do not exceed 40°C during the initial evaporation phase when hydrazine liquid is present. Chemical splash proof goggles must be worn throughout the entire evaporation process.

When no more hydrazine distills over, the water bath is lowered. Final high boiling components (mainly aniline) are distilled under vacuum at temperatures up to 100°C using a hot air gun for heating. The flask is then removed and dried in an oven at 110°C for one hour and weighed as before to a constant weight.

4.3.7.2.2 Calculations.

$$\%NVR = \frac{\text{Weight of residue, g} \times 100}{V \times D}$$

where:

V = Volume of sample, mL

D = Density of hydrazine at measured temperature

4.3.7.2.3 Equipment.

- a. All glass rotary evaporator, Rinco-Buchi model VE 50 GD or equivalent.
- b. Flask, round bottom, 250 mL, with standard taper neck to fit evaporator.

MIL-PRF-87930A

- c. Water aspirator - glass or polyethylene.
- d. Desiccator
- e. Water bath (40°C)
- f. Hot air gun
- g. Drying oven (110°C)
- h. Analytical balance
- i. Standard taper teflon sleeve
- j. Safety glasses

4.3.8 Carbon dioxide. The carbon dioxide content of hydrazine shall be determined by the following method:

4.3.8.1 Carbon dioxide.

4.3.8.1.1 Procedure. Assemble the apparatus as shown in Figure 2 and connect a gas buret to the gas exit. Adjust the needle valve so that the flow at the gas exit is 50 - 100 mL/min. Adjust the gas chromatograph carrier gas flow to 30 - 60 mL/min, the column temperature to 100 to 150°C, and the detector temperature to 150 to 200°C. Adjust the detector current to the manufacturer's recommended level for nominal sensitivity. Position the gas sampling valve and the stopcocks so that sparge gas passes through the CO₂ trap and allow the system to purge in this manner for 45 minutes. After the apparatus has purged, cool the CO₂ trap to liquid nitrogen temperature to collect a sample for background CO₂ determination. Collect the sample for 45 minutes and then position the stopcocks so that the sparge gas bypasses the cooled portion of the trap. Position the gas sampling valve so that the carrier gas will flow through the bypass line of the trap. Warm the lower portion to ambient temperature. Inject the trapped gases into the gas chromatograph by rotation of the stopcocks to the collect position. Determine the CO₂ peak height or area and record the results. Position the gas sampling valve so the sparge gas is again flowing through the trap and cool the trap to liquid nitrogen temperature. Immediately inject a 0.25 mL propellant sample into the septum inlet of the apparatus and allow 45 min for complete transfer of the CO₂ from the sulfamic acid bubbler to the trap. Repeat the trapped sample injection sequence described earlier for the background determination and record the sample CO₂ peak height or area.

4.3.8.1.2 Propellant transfer. To achieve accurate CO₂ results, all propellant transfers must be performed in a CO₂-free atmosphere (i.e., a gaseous nitrogen dry box). Propellant in the sampler shall be transferred in an inert atmosphere to septum sealed vials. The vials shall be stored in an inert gas purged container when not actually being sampled. Use a gas tight syringe for the analysis. The gas tight syringe shall be cleaned and dried between each propellant sample injection into the apparatus.

4.3.8.1.3 Calculation. Calculate the CO₂ level of the propellant as follows:

MIL-PRF-87930A

$$\%CO_2 = (R_s - R_b) \times S$$

where:

$R_s - R_b$ = CO_2 response due to the sample minus CO_2 response due to the background, peak height or area.

S = Sensitivity, % CO_2 per unit response.

4.3.8.1.4 Calibration. Accurately weigh 0.130 g ammonium carbonate monohydrate (ACS) $[(NH_4)_2CO_3 \cdot H_2O]$ into a tared glass vessel which will accept a vapor tight cap and will contain 100 mL of liquid. Place the vessel in the transfer apparatus (dry box). Transfer 100 mL of propellant to the vessel; cap the vessel. Remove the vessel from the transfer apparatus and weigh the container. Calculate the CO_2 added as follows:

$$\%CO_2 \text{ added} = \frac{0.130 \times 44.01 \times 100}{[total \text{ wt} - (tare + 0.130)] \times 114.1}$$

Transfer a portion of the calibration standard to a septum sealed vial and use the procedure described in 4.3.8.1 to determine the response due to the CO_2 sensitivity of the apparatus as follows:

$$S = \frac{\%CO_2 \text{ added}}{R_{std} - R_s}$$

where:

$R_{std} - R_s$ = The response due to the CO_2 in the standard minus the response due to the sample, peak height or area.

4.3.8.1.5 Reagents and equipment.

4.3.8.1.5.1 Reagents.

- a. Sulfamic acid, aqueous, 90% saturated solution.
- b. Bromcresol green, indicator, several drops added to the sulfamic acid solution will provide a visual indication of when the solution is spent.
- c. Charcoal, coconut, 60/80 mesh, activated.
- d. Ammonium carbonate monohydrate, ACS Reagent Grade.
- e. Liquid nitrogen.
- f. Magnesium perchlorate, anhydrous, granular.
- g. Water, distilled or deionized.
- h. Helium, gaseous, conforming to MIL-P-27407, two cylinders.

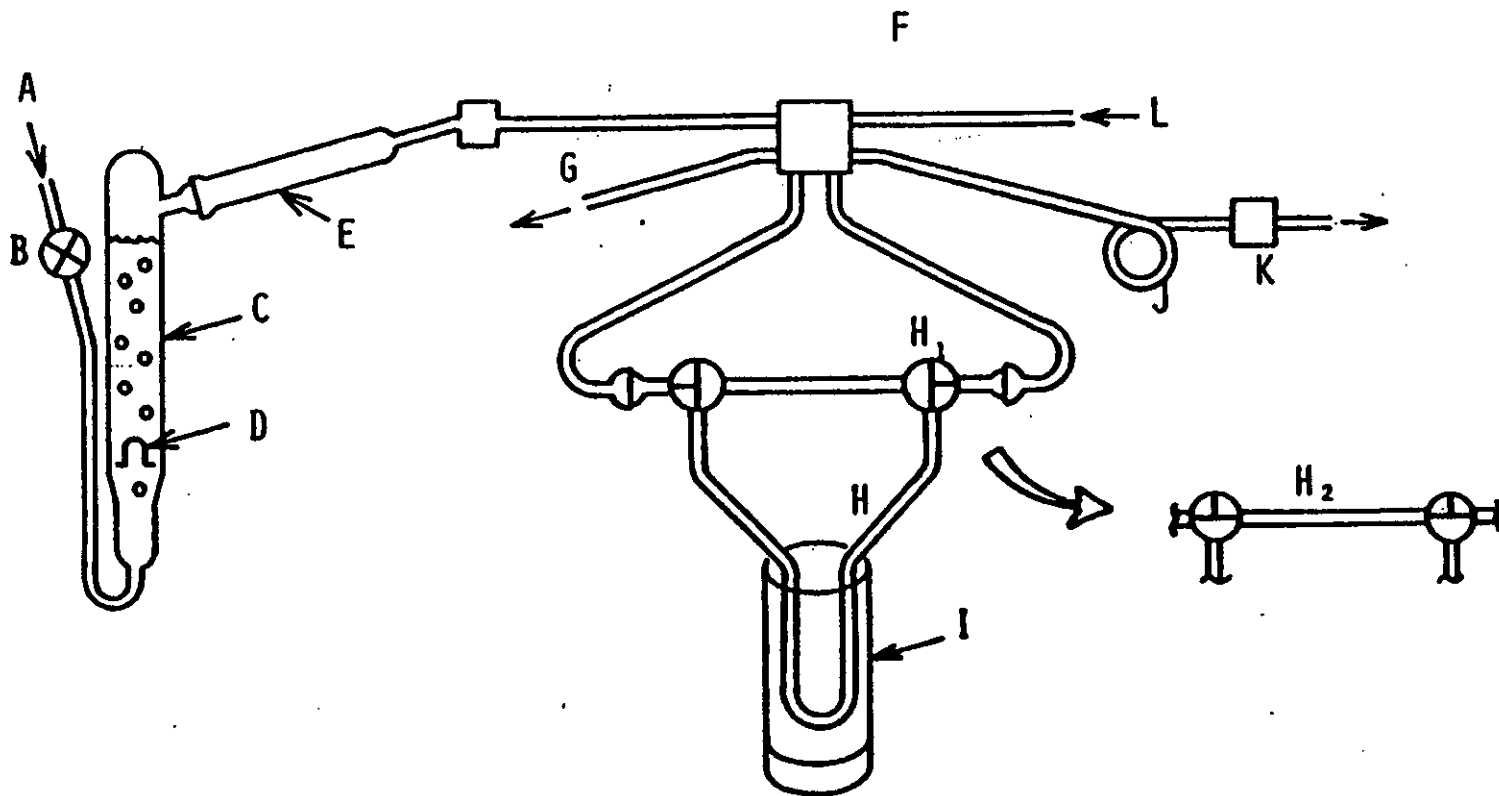

17

A - Sparge gas inlet
 B - Needle valve
 C - Reactor with coarse frit and sulfamic acid solution
 D - Septum inlet for propellant

E - $Mg(ClO_4)_2$ drying tube
 F - 6 or 8 port gas sampling valve
 G - Sparge gas vent
 H - LN_2 trap for CO_2
 H₁ (collect position)
 H₂ (bypass position)

I - Dewar for LN_2
 J - Charcoal GC column
 K - TC Detector
 L - Carrier gas inlet

FIGURE 2. CO_2 Apparatus

MIL-PRF-87930A

MIL-PRF-87930A

4.3.8.1.5.2 Equipment.

- a. Reactor, sulfamic acid, constructed so that the volume is approximately 75 cc, borosilicate glass. (See Figure 2.)
- b. Drying tube, $Mg(ClO_4)_2$, approximately 6" x 1/2", borosilicate glass.
- c. Trap, CO_2 , borosilicate glass, constructed with 6 mm OD tubing, the lower loop should contain glass beads to increase the condensing surface area.
- d. Valve, gas sampling, 6 or 8 port.
- e. Valve, needle, for regulation of the sparge gas.
- f. Dewar, conical, to fit trap.
- g. Gas chromatograph, equipped with a thermal conductivity detector, 6' x 1/8" 60/80 mesh charcoal column.
- h. Recorder, potentiometric, 1 mv span, 1 second full scale pen speed.
- i. Integrator, mechanical or digital, optional.

4.3.9 Other volatile carbonaceous material. Other volatile carbonaceous material shall be determined by a gas chromatographic method.

4.3.9.1 Procedure. Use the column, test conditions, and sample size described in paragraph 4.3.2.1. A flame ionization detector shall be used instead of the thermal conductivity detector. UDMH, methanol, and isopropyl alcohol emerge from the column as a single peak and MMH emerges immediately after the water peak. Ammonia, which emerges prior to the combined UDMH/alcohols peak shall not be summed with the carbonaceous material. Aniline will emerge from the column 30 - 45 minutes after the first injection. Allow the baseline to stabilize before injecting a second series of samples.

4.3.9.2 Calibration. Add 9.6 μL of UDMH and 8.5 μL of MMH to 75 mL of propellant sample contained in a 4 ounce screw capped bottle. Cap the bottle and mix the solution thoroughly. Transfer a portion of this calibration mixture to the sample vial. Analyze both samples and record the areas of the UDMH and MMH peaks.

4.3.9.3 Calculations. The combined UDMH/alcohols peak shall be calculated as percent UDMH. MMH is calculated separately.

$$\%UDMH = \frac{0.01A_s}{A_c - A_s}$$

where:

A_s = Area of sample UDMH times its attenuation factor.

A_c = Area of calibration UDMH times its attenuation factor.

$$\%MMH = \frac{0.01A_s}{A_c - A_s}$$

where:

MIL-PRF-87930A

A_s = Area of sample MMH times its attenuation factor.

A_c = Area of calibration MMH times its attenuation factor.

$$\% \text{Other volatile carbonaceous material} = \% \text{UDMH} + \% \text{MMH}$$

NOTE

Peak height may be substituted for peak area providing peak is sharp.

4.3.9.4 Reagents and equipment. The following reagents and equipment shall apply as test conditions of 4.3.9.

4.3.9.4.1 Reagents.

- a. UDMH - conforming to MIL-PRF-25604.
- b. MMH - conforming to MIL-P-27404.
- c. Reagents - as required in 4.3.2.

4.3.9.4.2 Equipment.

- a. Bottle = 4 ounce glass, narrow mouth, screw capped, plastic lined cap.
- b. Cylinder or syringe = 100 mL capacity graduated in 5 mL increments.
- c. As required in 4.3.2, except gas chromatograph shall be equipped with a flame ionization detector.

5. PACKAGING

5.1 Packaging. For acquisition purposes, the packaging requirements shall be as specified in the contract or order (see 6.2). When actual packaging of materiel is to be performed by DoD personnel, these personnel need to contact the responsible packaging activity to ascertain requisite packaging requirements. Packaging requirements are maintained by the Inventory Control Point's packaging activity within the Military Department or Defense Agency, or within the Military Department's System Command. Packaging data retrieval is available from the managing Military Department's or Defense Agency's automated packaging files, CD-ROM products, or by contacting the responsible packaging activity.

6. NOTES

(This section contains information of a general or explanatory nature that may be helpful but is not mandatory.)

6.1 Intended use. The propellant described by this specification is intended for use as fuel for gas generators.

6.2 Acquisition requirements. Acquisition documents must specify the following:

MIL-PRF-87930A

- a. Title, number, and date of the specification.
 - b. Issue of DoDISS to be cited in the solicitation, and, if required, the specific issue of individual documents referenced (see 2.2.1 and 2.3).
 - c. Quantity by weight in pounds (avoirdupois).
 - d. When other component limits are required (3.1).
 - e. When test methods are other than specified (3.1).
 - f. When sampling is other than specified (4.2).
 - g. When disposition of rejected product is required (4.2.2).
- 6.3 Part or identifying number (PIN). The PIN to be used for propellant acquired to this specification is created as follows:

M 87930 - Example of PIN: M87930

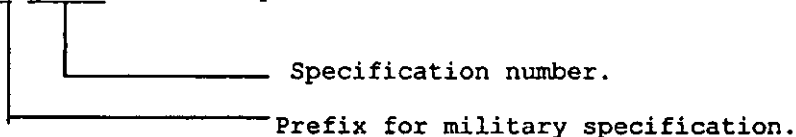

Specification number.

Prefix for military specification.

6.4 Subject term (key word listing).

Fuel
Hydrazine
Gas generator
Propellant

6.5 Changes from previous issue. Marginal notations are not used in this revision to identify changes with respect to the previous issue due to the extent of the changes.

Custodians
Air Force - 68

Review Activities
Air Force - 19

Preparing Activity
Air Force - 68

(Project 9135-0146)

STANDARDIZATION DOCUMENT IMPROVEMENT PROPOSAL

INSTRUCTIONS

1. The preparing activity must complete blocks 1, 2, 3, and 8. In block 1, both the document number and revision letter should be given.
2. The submitter of this form must complete blocks 4, 5, 6, and 7.
3. The preparing activity must provide a reply within 30 days from receipt of the form.

NOTE: This form may not be used to request copies of documents, nor to request waivers, or clarification of requirements on current contracts. Comments submitted on this form do not constitute or imply authorization to waive any portion of the referenced document(s) or to amend contractual requirements.

I RECOMMEND A CHANGE:	1. DOCUMENT NUMBER MIL-PRF-87930A	2. DOCUMENT DATE (YYMMDD) 97/11/24
3. DOCUMENT TITLE Propellant, Hydrazine-Water (70% Hydrazine - 30% Water)		
4. NATURE OF CHANGE <i>(Identify paragraph number and include proposed rewrite, if possible. Attach extra sheets as needed.)</i>		
5. REASON FOR RECOMMENDATION		
6. SUBMITTER		
a. NAME <i>(Last, First, Middle Initial)</i>	b. ORGANIZATION	
c. ADDRESS <i>(include Zip Code)</i>	d. TELEPHONE <i>(include Area Code)</i>	e. DATE SUBMITTED (YYMMDD)
	(1) Commercial (2) AUTOVON <i>(if applicable)</i>	
8. PREPARING ACTIVITY		
a. NAME SA-ALC/SFSP	b. TELEPHONE <i>(include Area Code)</i>	
c. ADDRESS <i>(include Zip Code)</i> 1014 Billy Mitchell Blvd, STE 1 Kelly AFB, TX 78241-5603	(1) Commercial (210) 925-7847	(2) AUTOVON 945-7847
	IF YOU DO NOT RECEIVE A REPLY WITHIN 45 DAYS, CONTACT: Defense Quality and Standardization Office 5203 Leesburg Pike, Suite 1403, Falls Church, VA 22041-3466 Telephone (703) 756-2340 AUTOVON 289-2340	