

METRIC

MIL-PRF-85045/17C

17 June 2014

SUPERSEDING

MIL-PRF-85045/17B

16 September 1999

PERFORMANCE SPECIFICATION SHEET

CABLE, FIBER OPTIC, EIGHT FIBERS, ENHANCED PERFORMANCE, CABLE CONFIGURATION TYPE 2 (OFCC), APPLICATION B (SHIPBOARD), CABLE CLASS SM AND MM

This specification is approved for use by all Departments and Agencies of the Department of Defense.

The requirements for acquiring the product described herein shall consist of this specification sheet and MIL-PRF-85045.

CLASSIFICATION:

Fiber optic cable configuration type: 2 (OFCC)

Fiber optic cable class: MM (graded-index, glass core and glass cladding, multimode)

SM (dispersion-unshifted, glass core and glass cladding, single-mode)

DESIGN AND CONSTRUCTION:

Fiber: Class MM fibers shall be in accordance with MIL-PRF-49291/6.

Class SM fibers shall be in accordance with MIL-PRF-49291/7.

Buffer diameter: $900 \pm 50 \mu\text{m}$

OFCC: Dimensions and configuration: See [figure 1](#).

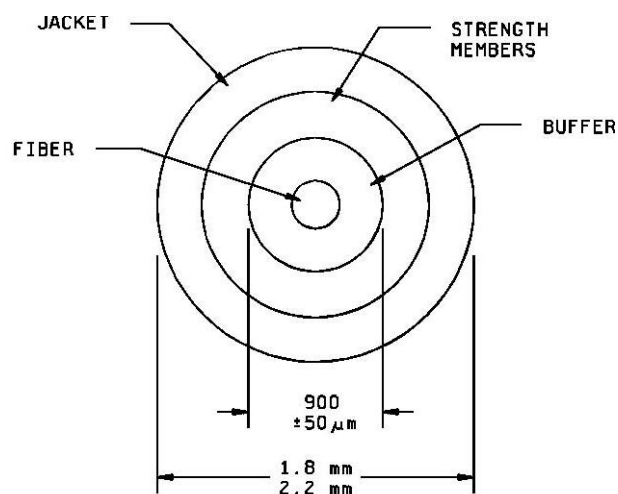

FIGURE 1. Optical fiber cable component.

Mass per unit length: <15 kg/km

Short-term minimum bend diameter: Eight times the OFCC outer diameter.

MIL-PRF-85045/17C

Long-term minimum bend diameter: Sixteen times the OFCC outer diameter.

Tensile Loading: >270 N

Dynamic bend tensile load: 90 N minimum

Jacket material: The OFCC jacket shall be composed of a low halogen, low smoke, low toxicity polymer material.

Finished cable:

Dimensions and configuration: See [figure 2](#). Eight OFCC units shall be helically laid over the central member. The minimum outer jacket thickness shall be not less than 1.2 mm (establishes compatibility with termination and penetration devices).

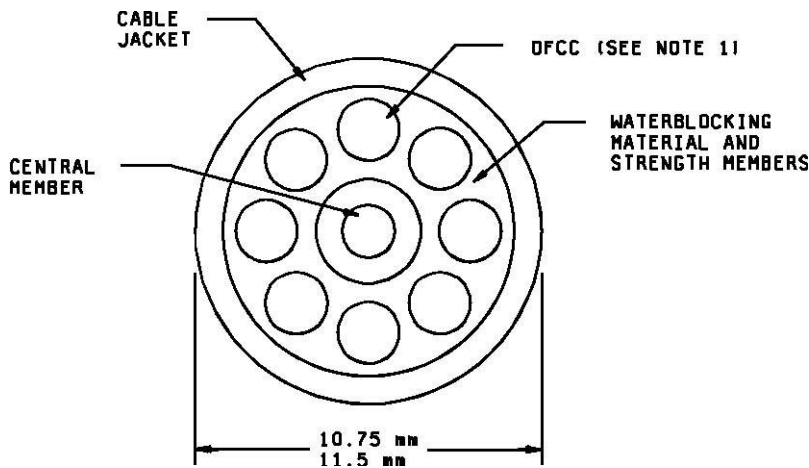

NOTE:

1. OFCC – Optical fiber cable component

FIGURE 2. Eight-OFCC fiber optic cable.

Number of fibers: 8 (one per OFCC)

Concentricity: >0.65

Mass per unit length: <175 kg/km

Jacket material: The overall jacket shall be composed of a low halogen, low smoke, low toxicity polymer material.

Cable jacket color: Shall be black or blue.

Short-term minimum bend diameter: Eight times the cable outer diameter. (The short-term minimum bend diameter is to be used in all environmental and mechanical tests which specify a cable minimum bend diameter.)

Long-term minimum bend diameter: Sixteen times the cable outer diameter.

Minimum continuous length: The minimum continuous length of all cables shall be not less than 0.5 km. If lengths less than 0.5 km are specified in the purchase order, a conformance inspection shall be performed on test specimens not less than 0.5 km in length from which the purchase order lengths are cut.

MIL-PRF-85045/17C

PERFORMANCE REQUIREMENTS:

Optical properties:

Maximum attenuation rate: 4.5 dB/km at 850±20 nm, 2.0 dB/km 1300±20 nm for Class MM fiber.
1.5 dB/km at 1310±20 nm and 1550±20 nm for Class SM fiber.

For cables with radiation cross-linked jackets, the change in attenuation rate measurement may be made up to 30 days after cross-linking of the cable jacket.

Bandwidth: Fiber with a minimum bandwidth of 500 MHz-km at 1300 nm shall be used (multimode cables only).

Bandwidth is not specified at 850 nm.

Change in optical transmittance: Measurements shall be made at 1300±20 nm.

Mechanical properties:

Tensile loading and elongation: Applicable, tensile loading >2700 N

Low temperature flexibility: The exposure temperature shall be -40 °C.

Cyclic flexing: 500 cycles at 25±2 °C and 100 cycles at -28±2 °C. Change in optical transmittance measurements are to be made every 100 cycles for the 500-cycle exposure and every 25 cycles for the 100-cycle exposure. Each change in optical transmittance measurement shall be performed with the test specimen in the same position in the test cycle. The cycling may be halted to perform the change in optical transmittance measurement.

Cable twist-bending: 500 cycles at 25±2 °C and 100 cycles at -28±2 °C. Change in optical transmittance measurements are to be made every 100 cycles for the 500-cycle exposure and every 25 cycles for the 100-cycle exposure. Each change in optical transmittance measurement shall be performed with the test specimen in the same position in the test cycle. The cycling may be halted to perform the change in optical transmittance measurement.

Impact: 50 cycles at 25±2 °C and 20 cycles at -40±2 °C. Upon final visual examination at all tested temperatures, there shall be no jacket damage such as splitting or cracking.

Hosing: Both low pressure and hydrostatic pressure are applicable.

Hydrostatic: 7.7 MPa for M85045/17-01P and M85045/17-02P.

Cable scraping resistance: 750 cycles

Cable-to-cable abrasion: 500 cycles

Environmental properties:

Temperature range:

Operating: -28 to 65 °C

Nonoperating: -40 to 70 °C

Storage: -40 to 70 °C

Temperature cycling: Change in optical transmittance measurements may be made periodically. At a minimum, one optical transmittance measurement shall be made over a period of 1 hour at the end of each temperature plateau.

Temperature humidity cycling: Change in optical transmittance measurements may be made periodically. At a minimum, one optical transmittance measurement shall be made at the end of each temperature plateau.

Temperature life (life aging): Applicable, except that the jacket material shall be tested at 175 °C for 4 hours.

MIL-PRF-85045/17C

Fluid immersion: Exposure to automobile gasoline and tap water are not required and the following test temperatures shall be used for the fluids indicated: fuel oil (98 to 100 °C), turbine fuel (48 to 50 °C), and lubricating oil (98 to 100 °C).

Chemical properties:

Halogen content: <0.2 percent

Cross-link verification: This test is applicable for cables with cross-linked jackets only. The test shall be conducted in accordance with ICEA standard T-28-562 and run at 200 °C. The test shall be in the qualification test sequence using a specimen cut from the sample used in the thermal shock test and in the Group III testing of the Group C conformance test sequence. The hot creep elongation shall not exceed 100 percent, and the hot creep set shall not exceed 10 percent.

Identification marking: For mixed fiber cables, the identification marking shall include the following:
8 Fiber – 4 by 62.5/125, 4 by 9/125.

Part or identifying number (PIN) (see [table I](#)):

M85045/17-01P (Multimode)

M85045/17-02P (Single-mode)

“P” designates 7.7 Mpa hydrostatic pressure proof cable.

TABLE I. Supersession data.

PIN	Superseding
M85045/17-01P	M85045/13-01P
	M85045/17-01
	M85045/17-01N
	M85045/17-01T
M85045/17-02P	M85045/13-02P
	M85045/17-02
	M85045/17-02N
	M85045/17-02T

Qualification and conformance inspection: See [table II](#).

TABLE II. Qualification and conformance inspection.

Group	Qualification inspection	Requirement paragraph	Test paragraph	Cable length ^{1/} ^{2/} ^{3/} ^{4/}	Conformance inspection
I	Visual and mechanical inspection	3.4, 3.9, 3.10	4.7.2	3 samples, 0.5 km each ^{5/}	A
	Attenuation rate	3.5.1	4.7.4.1	3 samples, 0.5 km each ^{6/}	A
II	Crosstalk	3.5.3	4.7.4.3	3 samples, 0.5 km each ^{6/}	--
	Electromagnetic effects	3.7.16	4.7.6.16	1 specimen, 6 m ^{7/}	--

MIL-PRF-85045/17C

TABLE II. Qualification and conformance inspection – Continued.

Group	Qualification inspection	Requirement paragraph	Test paragraph	Cable length ^{1/} ^{2/} ^{3/} ^{4/}	Conformance inspection
III	Temperature cycling	3.7.1	^{8/}	2 samples, 0.5 km each ^{6/} (1 on reel, 1 off)	C
	Temperature humidity cycling	3.7.3	4.7.6.3	2 samples, 0.5 km each ^{9/}	C
	Storage temperature	3.7.4	4.7.6.4	2 samples, 0.5 km each ^{9/}	--
	Low temperature flexibility (cold bend)	3.6.3	4.7.5.3	2 specimens, 8 m each ^{10/}	B
	Cyclic flexing	3.6.4	4.7.5.4	6 specimens, 5 m each ^{11/} (2 specimens at each temp)	--
	Crush	3.6.5	4.7.5.5	2 specimens, 5 m each ^{10/}	--
	Cable twist-bend	3.6.6	4.7.5.6	6 specimens, 5 m each ^{11/} , (3 specimens at each temp)	C
	Impact	3.6.8	4.7.5.8	2 specimens, 5 m each ^{9/}	C
	Temperature life (life aging)	^{8/}	^{8/}	2 specimens, 300 m each ^{10/}	C
	Tensile loading and elongation	3.6.1	4.7.5.1	2 specimens, 150 m each ^{12/}	C
	Operating tensile loading	3.6.1.1	4.7.5.1.1	2 specimens, 150 m each ^{13/}	C
	Fungus resistance	3.8.4	4.8.4	2 specimens, 0.5 m each ^{10/}	--
	Cable element removability	3.6.18	4.7.5.18	2 specimens, 0.5 m each ^{10/}	C
IV	Thermal shock	3.7.2	4.7.6.2	1 specimen, 0.49 km each ^{6/} (on reel)	--
	Weathering	3.7.8	4.7.6.8	1 specimen, 2 m ^{14/} and 3 material samples ^{15/}	--
	Fluid immersion	3.7.9	4.7.6.9	1 specimen, 2 m ^{14/} and 3 material samples ^{15/} for each specified fluid	C
	Paint susceptibility	3.7.15	4.7.6.15	2 specimens, 2 m ^{16/}	--
	Jacket self-adhesion or blocking	3.7.11	4.7.6.11	1 specimen, 30 m ^{14/}	--
	Shock	3.7.13	4.7.6.13	1 specimen, 30 m ^{14/}	--
	Dynamic bend	3.6.2	4.7.5.2	1 specimen, 150 m ^{17/}	B
	Hosing: low pressure	3.6.12.1	4.7.5.12.1	1 specimen, 1.5 m ^{13/}	C
	Hosing: hydrostatic	3.6.12.2	4.7.5.12.2	1 specimen, 2 m ^{13/}	C
	Radial compression (for application B only)	3.6.7	4.7.5.7	1 specimen, 10 m ^{13/}	--
	Corner bend	3.6.9	4.7.5.9	2 specimens, 5 m ^{16/}	--
	OFCC kink	^{8/}	^{8/}	2 specimens, 1 m ^{16/}	--

MIL-PRF-85045/17C

TABLE II. Qualification and conformance inspection – Continued.

Group	Qualification inspection	Requirement paragraph	Test paragraph	Cable length ^{1/} ^{2/} ^{3/} ^{4/}	Conformance inspection
	Cross-link verification	^{8/}	^{8/}	2 specimens, 1 m ^{16/}	C
V	Dripping	3.6.13	4.7.5.13	1 specimen, 30 cm ^{14/}	--
	Cable jacket tear strength	3.6.14	4.7.5.14	5 flat extruded jacket material strips ^{18/}	C
	Cable jacket material tensile strength and elongation	3.6.15	4.7.5.15	5 specimens ^{19/}	--
	Cable abrasion resistance	3.6.16	4.7.5.16	4 specimens, 2 m ^{20/}	C
	Cable shrinkage	3.6.17	4.7.5.17	3 specimens, 0.5 m ^{16/}	C
	Durability of identification	3.6.19	4.7.5.19	3 specimens, 2 m each ^{16/}	--
	Flame extinguishing and smoke generation	3.7.12.2	4.7.6.12.2	1 specimen, 50 m ^{14/}	C
	Water absorption	3.7.14	4.7.6.14	2 specimens, extruded jacket material strips ^{19/}	--
VI	Acid gas generation	3.8.1	4.8.1	1 specimen, 1 m ^{21/}	C
	Halogen content	3.8.2	4.8.2	1 specimen, 1m ^{21/}	--
	Toxicity index	3.8.3	4.8.3	1 specimen, 1 m ^{21/}	C
	Smoke index	3.8.5	4.8.6	1 specimen, 1 m ^{21/}	C

MIL-PRF-85045/17C

TABLE II. Qualification and conformance inspection – Continued.

NOTES:

- ^{1/} Tolerance on 0.5-km length is ± 5 percent, provided that results are normalized to 1 km.
- ^{2/} Tolerance on shorter lengths is ± 5 percent.
- ^{3/} A sample is the initial 0.5-km cable length.
- ^{4/} A specimen is a cable length that is cut from the initial 0.5-km cable length (i.e., the sample) or is cut from a longer previous cut length (i.e., cut from a longer specimen).
- ^{5/} The visual and mechanical inspection shall only be conducted on a 2-m section of each sample.
- ^{6/} The same samples as used in the visual and mechanical inspection shall be used.
- ^{7/} A specimen cut from one of the visual and mechanical inspection test samples shall be used.
- ^{8/} As stated under the applicable tests in this specification sheet.
- ^{9/} The same samples as used in the temperature cycling test shall be used.
- ^{10/} A specimen cut from each sample used in the temperature cycling test shall be used.
- ^{11/} Three specimens cut from each sample used in the temperature cycling test shall be used.
- ^{12/} Specimens cut from the specimen used in the temperature life (life aging) test shall be used.
- ^{13/} The same specimen as used in the tensile loading and elongation test shall be used.
- ^{14/} A specimen cut from the specimen used in the thermal shock test shall be used.
- ^{15/} Three flat extruded jacket material strips as specified in 4.7.5.15 shall be used in this test.
- ^{16/} Specimens cut from the specimen used in the thermal shock test shall be used.
- ^{17/} A specimen cut from the specimen used in the thermal shock test or one of the specimens used in the tensile loading and elongation test shall be used.
- ^{18/} Flat extruded jacket material strips (i.e., strips of flat extruded material with the same composition of the cable jacket and of sufficient dimensions in which dumbbells can be cut) prepared as specified in 4.7.5.14 cited method and obtained from flat extruded material that underwent the thermal shock test shall be used.
- ^{19/} Flat extruded jacket material as specified in 4.7.5.15 shall be used in this test.
- ^{20/} Specimen cut from the specimen used in the thermal shock test shall be used. Two specimens shall be used for scraping abrasion, and two specimens shall be used in the cable-to-cable abrasion testing.
- ^{21/} A specimen cut from one of the samples used in the temperature cycling test or specimen used in the thermal shock test shall be used.

Qualification by similarity:

Manufacturers who are qualified under this specification sheet for multimode fiber cable (M85045/17-01) and whose single-mode fiber cable passes the tests and inspections specified in [table III](#) are qualified under this specification sheet for single-mode fiber cable (M85045/17-02). This qualification by similarity is applicable if the only difference between the previously qualified cable and the cable under test is that the optical fiber had been changed from a multimode fiber to a single-mode fiber. Testing may be performed on either one or two lengths of cable, each with a minimum length of 0.5 km. Test order must be observed up to and including the storage temperature test. If only one cable length is used, the thermal shock test shall be performed after the storage temperature test.

MIL-PRF-85045/17C

TABLE III. Qualification and conformance by similarity (fiber).

Group	Inspection	Qualification inspection M85045/17-02 ^{1/}	Conformance inspection M85045/17-02 ^{2/}
I	Visual and mechanical	X	A
	Attenuation rate	X	A
III	Temperature cycling	X	C
	Temperature humidity cycling	X	C
	Storage temperature	X	--
	Cyclic flexing	X	--
	Crush	X	--
	Cable twist-bending	X	C
	Impact (low temperature only)	X	C
	Tensile loading and elongation	X	C
	Operating tensile loading	X	C
IV	Thermal shock	X	--
	Dynamic bend	X	B

NOTES:

^{1/} Where manufacturers are qualified for MIL-PRF-85045/17-01 and are pursuing qualification for MIL-PRF-85045/17-02.

^{2/} Where manufacturers are qualified for MIL-PRF-85045/17-01 and MIL-PRF-85045/17-02 and are performing conformance testing for M85045/17-02.

CHANGES FROM PREVIOUS ISSUE: Marginal notations are not used in this revision to identify changes with respect to the previous issue due to the extent of the changes.

Custodians:

Army – CR
Navy – SH
Air Force – 85
NASA – NA

Preparing activity:

Navy – SH
(Project 6015-2012-014)

Review activities:

Army – AR, AV, MI
Navy – EC, YD
Air Force – 02, 19, 70, 99
DLA – CC

NOTE: The activities listed above were interested in this document as of the date of this document. Since organizations and responsibilities can change, you should verify the currency of the information above using the ASSIST Online database at <https://assist.dla.mil>.