

INCH-POUND

MIL-PRF-83867C (USAF)

10 August 1998

SUPERSEDING

MIL-C-83867B (USAF)

22 November 1994

PERFORMANCE SPECIFICATION

CONNECTOR, OXYGEN MASK HOSE, NON-EJECTION TYPE

This specification is approved for use by the Department of the Air Force and is available for use by all Departments and Agencies of the Department of Defense.

1. SCOPE

1.1 Scope. This specification covers the non-ejection type mask hose connector assembly used in conjunction with the aviator oxygen mask or full-face fire fighter's mask.

2. APPLICABLE DOCUMENTS

2.1 General. The documents listed in this section are cited in sections 3 and 4 of this specification. These lists do not include documents cited in other sections of this specification or recommended for additional information or as examples. While every effort has been made to ensure the completeness of these lists, document users are cautioned that they must meet all specified requirements documents cited in sections 3 and 4 of this specification, whether or not they are listed.

2.2 Government documents.

2.2.1 Specifications and standards. The following specifications and standards form a part of this document to the extent specified herein. Unless otherwise specified, the applicable issues of these documents are those listed in the specific issue of the Department of Defense Index of Specifications and Standards (DoDISS) and supplement thereto, cited in the solicitation (see 6.2).

SPECIFICATIONS

FEDERAL

BB-A-1034 - Compressed Air, Breathing

BB-N-411 - Nitrogen, Technical

DEPARTMENT OF DEFENSE

MIL-O-27210 - Oxygen, Aviator's Breathing,
Liquid and Gas

Beneficial comments (recommendations, additions, deletions) and any pertinent data that may be of use in improving this document should be addressed to: Resources & Logistics Services Division, SA-ALC/TILDD, 485 Quentin Roosevelt Road, Kelly AFB, TX 78241-6425, by using the Standardization Document Improvement Proposal (DD Form 1426) appearing at the end of this document or by letter.

MIL-PRF-83867C (USAF)

STANDARDS

FEDERAL

FED-STD-595 - Colors Used in Government Procurement

DEPARTMENT OF DEFENSE

MS22058 - Connector, Oxygen Hose to Regulator

(Unless otherwise indicated, copies of the above specifications and standards are available from the Standardization Document Order Desk, 700 Robbins Ave, Building 4D, Philadelphia, PA 19111-5094.)

2.2.2 Other Government documents, drawings and publications. The following other Government documents, drawings and publications form a part of this document to the extent specified herein. Unless otherwise specified, the applicable issues are those cited in the solicitation.

DRAWINGS

US AIR FORCE

56A3696 - Gasket, Connector, Oxygen Mask to Regulator

57B3623 - Ring, Retaining, Demand Mask to Regulator Tube, Internal

(Copies of drawings required by suppliers in connection with specific procurement functions should be obtained from the procuring activity or as directed by the contracting officer.)

2.3 Non-Government publications. The following documents form a part of this document to the extent specified herein. Unless otherwise specified, the applicable issues of the documents which have been adopted by the DoD are those listed in the specific issue of the DoDISS cited in the solicitation. Unless otherwise specified, the documents not listed in the DoDISS are the issues of the documents cited in the solicitation (see 6.2).

AMERICAN SOCIETY FOR TESTING AND MATERIALS (ASTM)

ASTM B633 - Standard Specification for Electrodeposited Coatings of Zinc On Iron and Steel (DoD-adopted)

(Application for copies should be addressed to the American Society for Testing and Materials, 1916 Race St. Philadelphia, PA 19103-1187.)

SOCIETY OF AUTOMOTIVE ENGINEERS (SAE)

AMS 2417E - Plating, Nickel-Zinc Alloy (DoD-adopted)

(Application for copies should be addressed to Society of Automotive Engineers, Inc, 400 Commonwealth Dr, Warrendale, PA 15096-0001.)

2.4 Order of precedence. In the event of a conflict between the text of this document and the references cited herein, the text of this document takes precedence. Nothing in this document, however, supersedes applicable laws and regulations unless a specific exemption has been obtained.

3. REQUIREMENTS

MIL-PRF-83867C (USAF)

- 3.1 Qualification. The connectors furnished under this specification shall be products that are authorized by the qualifying activity for listing on the applicable qualified products list at the time set for opening of bids (see 4.2 and 6.3).
- 3.2 Recycled, recovered or environmentally preferable materials. Recycled, recovered, or environmentally preferable materials should be used to the maximum extent possible, provided that the material meets or exceeds the operational and maintenance requirements and promotes economically-advantageous life-cycle cost.
- 3.3 Materials. All materials shall be suitably treated to resist corrosion due to electrolytic decomposition, fungus, salt spray, and any other atmospheric condition that may be encountered during operational use or storage. The use of toxic chemicals, hazardous substances, and ODCs shall be avoided, whenever feasible.
- 3.3.1 Nonmagnetic materials. Except where magnetic materials offer definite advantages, nonmagnetic materials shall be used for all components.
- 3.3.2 Nonmetallic materials. Any nonmetallic materials that are affected adversely by continued use with oxygen shall not be used. Plastics which crack, chip, or permanently set under a compressive load of 200 psi shall not be used.
- 3.3.3 Protective treatment. Cadmium coating or plating shall not be used. Any parts requiring zinc plating shall be protected in accordance with AMS 2417 or ASTM B633 (see 6.6).
- 3.3.4 Wear Resistant Treatment. All aluminum parts shall be treated to provide a wear resistant surface (see 6.6).
- 3.4 Design. The oxygen mask connector shall consist of the main housing, one aircraft supply port with a restrictor valve that has disconnect anti-suffocation capability, and a hose connection with restraint pin as shown in figure 1. The connector shall be complete when the parts are assembled with the main housing.
- 3.5 Interface.
- 3.5.1 Aircraft supply port. The aircraft supply port of the connector shall have a restrictor valve that has disconnect anti-suffocation capability, which permits the user to breathe normally when the restrictor valve is inserted into a connector conforming to MS22058. The restrictor valve shall be guided internally to prevent tilting or jamming of the valve mechanism. The valve actuator shall be positively locked to the restrictor valve.
- 3.5.2 Restraint pin. A restraint pin shall be attached to the hose connection part of the connector to provide an attachment point for the oxygen mask hose restraint cord as shown in figure 1.
- 3.5.3 Color. The color of the connector shall be black, approximately matching Color No. 37038 of FED-STD-595.
- 3.6 Construction. The connector shall be constructed so that no parts will become loose in service. It shall be built to withstand the strains, jars, vibrations, and any other conditions incident to shipment, storage, installation, and service.
- 3.6.1 Screw assemblies. Assembly screws and bolts shall be tight. Tight shall be defined to mean that the screw or bolt cannot be appreciably tightened further without damage to the screw, bolt, or screw threads.
- 3.6.2 Installation of threaded parts. All threaded parts shall be positively installed by self-locking nuts, or any other approved methods so that the threaded parts will not work loose in service.
- 3.6.3 Lubrication. Lubrication used in any component of the connector that may be exposed to oxygen shall be approved by the procuring activity (see 6.7).

MIL-PRF-83867C (USAF)

3.6.4 Cleanliness. The connectors shall be free of oil, grease, debris, and any other contaminant that creates a hazard in an oxygen environment.

3.7 Performance.

3.7.1 Disconnection force. The aircraft supply port of the connector shall disconnect from a jig conforming to MS22058 when a load of 12 to 20 pounds is applied along the longitudinal axis of the aircraft supply port.

3.7.2 Disconnection force reliability. The disconnection force shall remain in the range specified in 3.7.1 for a minimum of 500 connection-disconnection cycles.

3.7.3 Leakage. When subjected to an internal pressure of 1 psi, leakage of the connector shall not exceed 0.01 liter per minute (LPM) between -65 and 160 °F.

3.7.4 Pressure drop through connector. With the valve closed and pressure or suction applied to obtain a flow of 15 LPM from the regulator to the mask end, the pressure drop through the connector shall be within 4 to 6 inches of water.

3.7.5 Pressure drop through connector with jig. With the connector mated to a jig that has internal dimensions of the connector specified in MS22058, the pressure drop through the assembly shall not exceed the values shown in table I.

TABLE I. Pressure drop in assembly.

Flow of Oxygen (LPM)	Pressure Drop (Inches of Water)
135	1.7
90	0.80
70	0.50
50	0.32
30	0.10
0	0

3.7.6 Reliability. The connector shall have a minimum mean time between failures (MTBF) of 600 hours in order to provide a 16-hour mission reliability of 0.98.

3.7.7 Longevity. The connector shall have a minimum operating life span of 2,000 hours.

3.7.8 Restraint pin. The minimum force to separate the restraint pin from the connector shall be 110 pounds.

3.7.9 Odor. The connector shall have no objectionable odors during operational use.

MIL-PRF-83867C (USAF)

3.8 Item Identification. The connector shall be permanently marked with the following information:

Connector, Mask Hose
Manufacturer's Part Number
Contract Order Number
Manufacturer's Name or Code

3.9 Interchangeability. All parts having the same manufacturer's part number shall be functionally and dimensionally interchangeable.

4. VERIFICATION

4.1 Classification of inspections. The inspection requirements specified herein are classified as follows:

- a. Qualification inspection (see 4.2)
- b. Conformance inspection (see 4.3)

4.2 Qualification inspection. Qualification inspection shall consist of all tests specified in 4.6 except 4.6.2. The disconnection force test specified in 4.6.2 is a conformance inspection only.

4.2.1 Qualification samples. The qualification samples shall consist of three connectors prepared in accordance with this specification and representative of production.

4.3 Conformance inspection. Conformance inspection shall consist of:

- a. Individual inspection (see 4.3.1)
- b. Sampling inspection (see 4.3.2)

4.3.1 Individual inspection. Each connector shall be subjected to the following inspections.

- a. Examination of product (see 4.6.1)
- b. Disconnection force (see 4.6.2)

4.3.2 Sampling inspection.

4.3.2.1 Sample size. The sample size shall be three connectors chosen at random from each lot of 100 or less connectors.

4.3.2.2 Sampling tests. The samples shall be subjected to the following tests:

- a. Leakage, except that only the 77 ± 18 °F portion of the test shall be conducted (see 4.6.4).
- b. Pressure drop through connector (see 4.6.5).
- c. Odor (see 4.6.9).

4.4 Test conditions.

4.4.1 Atmospheric conditions. Unless otherwise specified in the acquisition documents (see 6.2), all tests required by this specification shall be made at an atmospheric pressure of 28 to 32 inches of mercury, at a

MIL-PRF-83867C (USAF)

temperature of 77 ± 18 °F, and at a relative humidity of 80% or less. When tests are conducted with atmospheric pressure or temperature substantially different from these values, proper allowance shall be made for the change in instrument reading.

4.4.2 Gas. The gas used in testing the connectors shall be oxygen conforming to type I of MIL-O-27210, water-pumped nitrogen conforming to BB-N-411, type I, class 1, grade B, or compressed air conforming to BB-A-1034, compressed source II, grade B. The water content shall be 0.3 milligrams per liter at dew point -65 °F or 26.3 parts per million. If either nitrogen or air is used, appropriate density correction factors shall be applied to the flowmeter and to the performance of the connector.

4.5 Requirements cross-reference matrix. Table II provides a cross-reference matrix of the section 3 requirements tested or verified in the paragraphs.

TABLE II. Requirements cross-reference matrix.

REQUIREMENT	VERIFICATION	REQUIREMENT	VERIFICATION
3.1	4.2	3.6.3	4.6.1
3.3	4.6.1	3.7.1	4.6.2
3.3.1	4.6.1	3.7.2	4.6.3
3.3.2	4.6.1	3.7.3	4.6.4
3.3.3	4.6.1	3.7.4	4.6.5
3.3.4	4.6.1	3.7.5	4.6.6
3.4	4.6.1	3.7.6	4.6.7
3.5.1	4.6.1	3.7.7	4.6.8
3.5.2	4.6.1	3.7.8	4.6.10
3.5.3	4.6.1	3.7.9	4.6.9
3.6	4.6.7, 4.6.8	3.8	4.6.1
3.6.1	4.6.1	3.9	4.6.1
3.6.2	4.6.1		

4.6 Tests.

4.6.1 Examination of product. Each connector shall be examined to determine conformance with this specification with respect to materials, design, interface, lubrication, markings, interchangeability, and tightness or locking of threaded parts. There shall be no evidence of cuts, nicks, or holes in the connector hose.

4.6.2 Disconnection force. A jig that has the internal dimensions of the connector specified in MS22058 shall be used for this test. The connector shall be inserted and disconnected from the aircraft supply port by applying sufficient load along the longitudinal axis of port. The load shall be measured to determine conformance with the load requirements of 3.7.1. This test shall be performed three times on each connector.

4.6.3 Disconnection force reliability. The jig specified in 4.6.2 shall be used for this test. The connector shall be inserted and disconnected from the aircraft supply port at a rate of 20 cycles per 24-hour period for a total of 25 periods. The disconnection force for each cycle during the test shall meet the requirements of 3.7.1. The disconnection force for the three initial and three final cycles of each 20 cycle run shall be averaged and reported.

4.6.4 Leakage. The jig that is described in paragraph 4.6.2 shall be used for this test. The hose connection port shall be blocked by using an elastometric cap. An internal pressure of 1 psi shall be applied at temperatures of 77 ± 18 °F, -65 ± 2 °F, and 160 ± 2 °F. The total leakage shall not exceed 0.01 LPM.

MIL-PRF-83867C (USAF)

4.6.5 Pressure drop through connector. With the valve closed, pressure or suction shall be applied to the connector to obtain a flow of 15 LPM from the regulator end to the mask end. The pressure drop through the connector shall be 4 to 6 inches of water. The pressure tap shall be a suitable device (see 6.8) located on the mask side if suction is used and on the regulator side if pressure is used. The flow duct shall be constructed to ensure a straight flow for at least 6 inches immediately after leaving the connector if suction is used or for at least 6 inches immediately before entering the connector if pressure is used. The connector housing shall be mounted in a vertical position and its location shall permit free flow into the connector if suction is used and free flow out of the connector if pressure is used.

4.6.6 Pressure drop through connector with jig. The connector shall be connected to the same jig as in paragraph 4.6.2. With the valve actuator located at the top of the slots, pressure shall be applied to the jig to obtain flows in the range of 0 to 135 LPM from the regulator end to the mask end. The pressure drop through the assembly shall be measured by a suitable device such as described in paragraph 6.8. Pressure drops through the assembly shall not exceed the values specified in table I.

4.6.7 Reliability. If required in the acquisition documents (see 6.2), the sample of connectors used for this test shall be subjected to simulated breathing cycles at a rate of 10-20 breathing cycles per minute at room temperature (77 ± 18 °F). Cyclic breathing of the connectors shall be accomplished with a peak flow rate of 30 LPM inhalation and exhalation, with the restrictor valve in the open position. During 20% of the time that the connectors are subjected to breathing cycles, they shall be vibrated at a frequency ranging from 500 to 2,500 cycles per minute, at a double amplitude of not less than 0.018 inch nor more than 0.020 inch. The connector shall be vibrated alternately in each of the 3 axes for 6 hours per axis. At least once every 24 hours of the breathing cycles, each connector shall be subjected to and shall meet the inspections specified in 4.6.2 (room temperature), 4.6.4, and one 20-cycle run as described in 4.6.7. No parts shall be replaced as preventative maintenance during reliability testing. Sufficient testing shall be conducted to demonstrate an MTBF of 600 hours at a confidence level of 0.9. At the conclusion of this testing the connectors shall be subjected to inspection as specified in 4.3.1.

4.6.8 Longevity. If required by the acquisition documents (see 6.2), the operating life span shall be verified by extending the reliability test to reach 2,000 hours of operation by each connector.

4.6.9 Odor. Gaseous oxygen shall be allowed to pass through the assembled connector at a rate not greater than 10 LPM for 1 minute. A smell test shall be conducted in a manner that shall prevent exterior odors from influencing the test. Using a minimum of 6 persons as testers, no more than 33% of the testers shall judge any odor as objectionable.

4.6.10 Restraint pin. The restraint pin shall be pulled at its midpoint while installed in the hose connector until the pin breaks or deforms to such an extent as to become dislodged from its position. The force required to cause this failure or deformation shall not be less than 110 pounds.

5. PACKAGING

5.1 General. For acquisition purposes, the packaging requirements shall be as specified in the contract or order (see 6.2). When actual packaging of materiel is to be performed by DoD personnel, these personnel need to contact the responsible packaging activity to ascertain requisite packaging requirements. Packaging requirements are maintained by the Inventory Control Point packaging activity within the Military Department or Defense Agency, or within the Military Department's System Command. Packaging data retrieval is available from the managing Military Department or Defense Agency automated packaging files, CD-ROM products, or by contacting the responsible packaging activity.

MIL-PRF-83867C (USAF)

6. NOTES

(This section contains information of a general or explanatory nature which may be helpful, but is not mandatory.)

6.1 Intended use. The connector covered by this specification is intended for oxygen masks in use on non-ejection aircraft and with full-face fire fighter's masks.

6.2 Acquisition requirements. Acquisition documents must specify the following:

- a. Title, number, and date of this specification.
- b. Issue of DODISS to be cited in the solicitation, and if required, the specific issue of individual documents referenced (see 2.1).
- c. If tests are to be conducted in other than atmospheric conditions (see 4.4.1).
- d. If a reliability test is required (see 4.6.7).
- e. If a longevity test is required (see 4.6.8).
- f. Packaging requirements (see 5.1).
- g. Data required.

6.3 Qualification. The attention of the contractors is called to the requirements with respect to products requiring qualification. Awards will be made only for products which are, at the time of award of contract, qualified for inclusion in the Qualified Products List (QPL No. 83867) whether or not such products have actually been listed by that date. In order that the manufacturers may be eligible to be awarded contracts or purchase orders for the products covered by this specification, they are urged to arrange to have the products that they propose to offer to the Federal Government tested for qualification. Information pertaining to qualification of products may be obtained from SA-ALC/TILDD, 485 Quentin Roosevelt Rd., Kelly AFB, TX 78241-6425.

6.4 Subject term (key word) listing.

Aircraft supply port	Non-ejection
Disconnection	Odor
Firefighter	Oxygen
Flange	Pressure
Jig	Supply port
Leakage	Threads
Mounting plate	Welding

6.5 Changes from previous issue. Marginal notations are not used in this revision to identify changes with respect to the previous issue due to the extensiveness of the changes.

6.6 Protective and wear resistant treatment. The following specifications may be used as a guide for 3.3.3 and 3.3.4:

MIL-S-5002	-	Surface Treatments and Inorganic Coatings for Metal Surfaces of Weapon Systems
MIL-A-8625	-	Anodic Coatings for Aluminum and Aluminum Alloys (Type III Coatings).

MIL-PRF-83867C (USAF)

6.7 Lubrication. MIL-G-27617 and MIL-G-47219 have been previously approved for use in oxygen systems.

6.8 Pressure measurement. A piezometer ring located 1.5 to 2.5 inches from the mask end of the connector has historically been used to read pressure. For pressure drops through the connector including the assembly in a jig, a piezometer ring may be located approximately 2 inches from the end of the connector.

6.9 Changes from previous issue. Marginal notations are not used in this revision to identify changes with respect to the previous issue due to the extensiveness of the changes.

MIL-PRF-83867C (USAF)

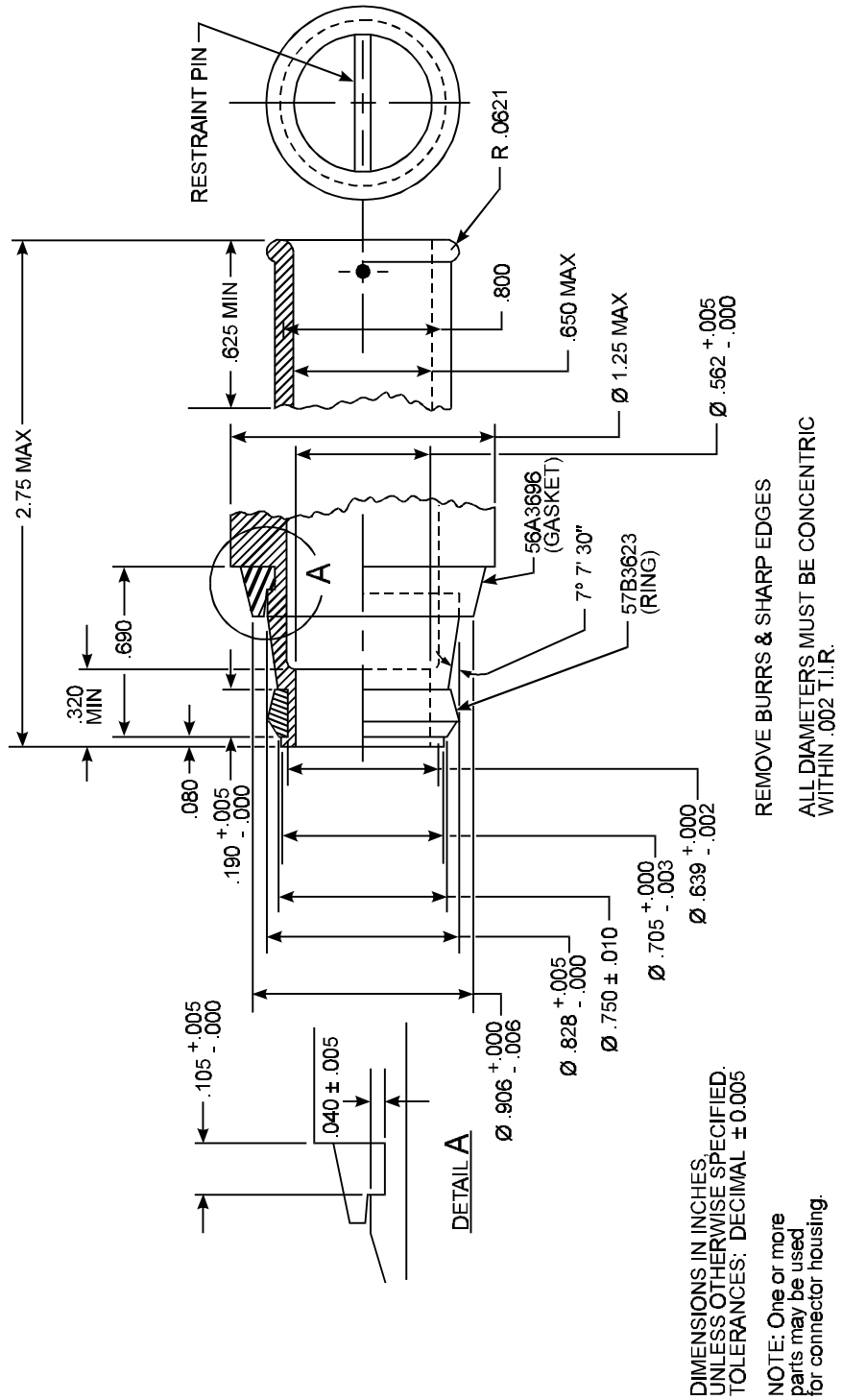

THIS ILLUSTRATION IS FOR REFERENCE ONLY

FIGURE 1. Mask port interface.

MIL-PRF-83867C (USAF)

Custodians:
Air Force - 99

Preparing Activity:
Air Force - 82

(Project No.1660-F752)

STANDARDIZATION DOCUMENT IMPROVEMENT PROPOSAL		
INSTRUCTIONS		
1. The preparing activity must complete blocks 1, 2, 3, and 8. In block 1, both the document number and revision letter should be given.		
2. The submitter of this form must complete blocks 4, 5, 6, and 7.		
3. The preparing activity must provide a reply within 30 days from receipt of the form.		
NOTE: This form may not be used to request copies of documents, nor to request waivers, or clarification of requirements on current contracts. Comments submitted on this form do not constitute or imply authorization to waive any portion of the referenced document(s) or to amend contractual requirements.		
I RECOMMEND A CHANGE:	1. DOCUMENT NUMBER MIL-PRF-83867C (USAF)	2. DOCUMENT DATE (YYMMDD) 980810
3. DOCUMENT TITLE CONNECTOR, OXYGEN MASK HOSE, NON-EJECTION TYPE		
4. NATURE OF CHANGE (Identify paragraph number and include proposed rewrite, if possible. Attach extra sheets as needed.)		
5. REASON FOR RECOMMENDATION		
6. SUBMITTER		
a. NAME (Last, First, Middle Initial)	b. ORGANIZATION	
c. ADDRESS (Include Zip Code)	d. TELEPHONE (Include Area Code) (1) Commercial (2) AUTOVON (If applicable)	7. DATE SUBMITTED (YYMMDD)
8. PREPARING ACTIVITY		
a. NAME SA-ALC/TILDD	b. TELEPHONE (Include Area Code) (1) Commercial (2) AUTOVON (210) 925-6314 945-6314	
c. ADDRESS (Include Zip Code) 485 QUENTIN ROOSEVELT RD BLDG 171 KELY AFB TX 78241-6425	IF YOU DO NOT RECEIVE A REPLY WITHIN 45 DAYS, CONTACT: Defense Quality and Standardization Office 5203 Leesburg Pike, Suite 1403, Falls Church, VA 22041-3466 Telephone (703) 756-2340 AUTOVON 289-2340	