

INCH-POUND

MIL-PRF-83726D  
17 November 2008  
SUPERSEDING  
MIL-PRF-83726C  
15 Jun 1999

## PERFORMANCE SPECIFICATION

### RELAYS, HYBRID AND SOLID STATE, TIME DELAY, GENERAL SPECIFICATION FOR

This specification is approved for use by all Departments and Agencies of the Department of Defense.

#### 1. SCOPE

1.1 Scope. This specification establishes the general requirements for time delay relays that are a combination of hybrid microcircuits, solid state electronics with an integral electromagnetic relay, or solid state output. Relays covered by this specification are intended for use in aerospace and associated ground support electrical and electronic systems and equipment (see 6.1). For additional application and caution information see 6.1.

1.2 Classification. Time delay relays covered by this specification shall be of the following types and classes, as specified (see 3.1 and 6.10):

#### Type

- I - Time delay on operate.
- IIA - Time delay on release (separate control and power terminals).
- IIB - Time delay on release (true).
- III - Interval timer.
- IV - Repeat cycle timer.
- V - Time sequence as specified (see 3.1).

#### Class

- A - Hybrid (integral electromagnetic relay qualified to MIL-PRF-39016).
- B - Hybrid (integral electromagnetic relay qualified to MIL-PRF-83536).
- C - Solid state.

1.2.1 Ratings. Time delay relays with electromechanical relay output and with contact ratings 10 A or greater are covered in class B.

Comments, suggestions or questions on this document should be addressed to Defense Supply Center Columbus, ATTN: VAT, Post Office Box 3990, Columbus, OH 43218-3990, or emailed to [relay@dla.mil](mailto:relay@dla.mil). Since contact information can change, you may want to verify the currency of this address information using the ASSIST Online database at [assist.daps.dla.mil](http://assist.daps.dla.mil).

## MIL-PRF-83726D

1.2.2 Part or Identifying Number (PIN). The PIN shall consist of the letter "M", basic specification number; specification sheet number, an assigned dash number (see 3.1), and mounting (when applicable) as shown in the following example:

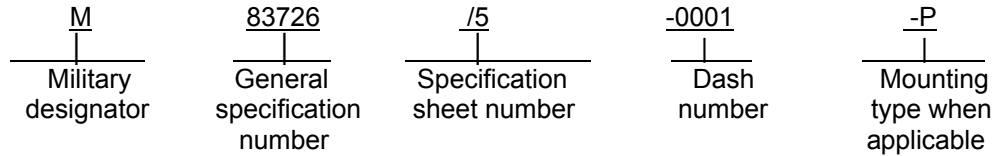

## 2. APPLICABLE DOCUMENTS

2.1 General. The documents listed in this section are specified in sections 3 and 4 of this specification. This section does not include documents cited in other sections of this specification or recommended for additional information or as examples. While every effort has been made to ensure the completeness of this list, document users are cautioned that they must meet all specified requirements of documents cited in sections 3 and 4 of this specification, whether or not they are listed.

### 2.2 Government documents.

2.2.1 Specifications, standards, and handbooks. The following specifications, standards, and handbooks form a part of this document to the extent specified herein. Unless otherwise specified, the issues of these documents are those cited in the solicitation or contract.

#### FEDERAL STANDARDS

[FED-STD-H28](#) - Screw Thread Standards for Federal Services.

#### DEPARTMENT OF DEFENSE SPECIFICATIONS

[MIL-PRF-15160/2](#) - Fuse, Instrument, Power, and Telephone (Nonindicating), Style F02.  
[MIL-PRF-15160/3](#) - Fuse, Instrument, Power, and Telephone (Nonindicating), Style F03.  
[MIL-PRF-38534](#) - Hybrid Microcircuits, General Specification for.  
[MIL-PRF-39016](#) - Relays, Electromagnetic, Established Reliability, General Specification for.  
[A-A-55568](#) - Headset-Microphone, Lightweight, General Requirements for  
[MIL-PRF-83536](#) - Relays, Electromagnetic, Established Reliability, 25 Amperes and Below, General Specification For.

#### DEPARTMENT OF DEFENSE STANDARDS

[MIL-STD-202](#) - Electronic and Electrical Component Parts.  
[MIL-STD-461](#) - Requirements for the Control of Electromagnetic Interference Characteristics of Subsystems and Equipment.  
[MIL-STD-704](#) - Aircraft Electric Power Characteristics.  
[MIL-STD-790](#) - Established Reliability and High Reliability Qualified Products List (QPL) Systems for Electrical, Electronic, and Fiber Optic Parts Specifications.  
[MIL-STD-883](#) - Microcircuits.  
[MIL-STD-1276](#) - Leads for Electronic Component Parts.  
[MIL-STD-1285](#) - Marking of Electrical and Electronic Parts.

(Copies of these documents are available online at <http://assist.daps.dla.mil/> or from the Standardization Document Order Desk, 700 Robbins Avenue, Building 4D, Philadelphia, PA 19111-5094.)

## MIL-PRF-83726D

2.3 Non-Government publications. The following documents form a part of this document to the extent specified herein. Unless otherwise specified, the issues of these documents are those cited in the solicitation or contract.

## AMERICAN NATIONAL STANDARDS INSTITUTE (ANSI)

[ANSI Y32.2](#) - Graphic Symbols for Electric and Electronic Diagrams.

(Copies of this document is available online at <http://www.ansi.org/> or from the American National Standards Institute, Incorporated, 25 West 43rd Street, New York, NY 10036.)

## ELECTRONICS INDUSTRIES ALLIANCE (EIA)

[EIA-557](#) - Statistical Process Control Systems.

(Copies of this document is available online at <http://www.eia.org/> or from the Electronics Industries Association, 2500 Wilson Boulevard, Arlington, VA 22201-3834.)

2.4 Order of precedence. In the event of a conflict between the text of this document and the references cited herein (except for related specification sheets), the text of this document takes precedence unless otherwise noted. Nothing in this document, however, supersedes applicable laws and regulations unless a specific exemption has been obtained.

## 3. REQUIREMENTS

3.1 Specification sheets. The individual item requirements shall be as specified herein and in accordance with the applicable specification sheet. In the event of any conflict between requirements of this specification and the specification sheet, the latter shall govern.

3.2 Pure tin. The use of pure tin, as an underplate or final finish, is prohibited both internally and externally. Tin content of (product) and solder shall not exceed 97 percent, by mass. Tin shall be alloyed with a minimum of 3 percent lead, by mass (see [6.4](#)).

3.3 Qualification. Relays furnished under this specification shall be products that are authorized by the qualifying activity for listing on the applicable qualified products list before contract award (see [4.2](#) and [6.3](#)).

3.4 Qualified Products List (QPL) system. The manufacturer shall establish and maintain a QPL system for parts covered by this specification. Requirements for this system are specified in [MIL-STD-790](#).

3.4.1 Statistical Process Center (SPC). As part of the overall [MIL-STD-790](#) QPL system, the manufacturer shall establish an SPC system that meets the requirements of [EIA-557](#).

3.4.2 Electrostatic discharge (ESD) control program. As part of the overall [MIL-STD-790](#) QPL system, the manufacturer shall establish and maintain an ESD control system. As a minimum, this program shall address the identification of ESD sensitive (ESDS), sub-components and end items, facilities, training design protection, handling procedures, marking, cleaning, packaging, and verification. A model ESD control program is available from the qualifying activity and may be used as a guideline document. Further guidance for ESD control is available from the EOS/ESD Association and the Electronics Industry Association (EIA).

## MIL-PRF-83726D

3.5 Materials. Materials shall be as specified herein. However, when a definite material is not specified, a material shall be used which will enable the relay to meet the performance requirements of this specification. Materials used shall be fungus inert, self-extinguishing, and shall not support combustion, give off noxious gases in harmful quantities, give off gases in quantities sufficient to cause explosion of sealed enclosures, cause contamination, or form current carrying tracks which prevent meeting the post test requirements specified herein. The use of silicone (see 6.10) or silicone compounds for any purpose other than external gaskets is prohibited. The selection of materials shall be as such as to provide maximum shelf life. Acceptance or approval of any constituent material shall not be construed as a guaranty of the acceptance of the finished product.

3.5.1 Metals. Metals shall be of a corrosion-resistant type or shall be plated or treated to resist corrosion. The use of mercury or mercury compounds is prohibited. The use of magnesium or magnesium alloys is prohibited (not applicable to contact systems).

3.5.1.1 Plated finishes.

- a. Pure tin plating is prohibited internally and externally. Tin-lead finish is acceptable provided that the minimum lead content is 3 percent. Other tin alloys are acceptable as approved by the qualifying activity.
- b. Pure zinc plating is prohibited internally and externally.
- c. Pure cadmium plating is prohibited internally and externally.

3.5.1.2 Dissimilar metals. When dissimilar metals are used in intimate contact with each other, protection against electrolysis and corrosion shall be provided. The use of dissimilar metals in contact, which tends toward active electrolytic corrosion (particularly brass, copper, or steel used in contact with aluminum or aluminum alloy), is not acceptable. However, metal spraying or metal plating of dissimilar base metals to provide similar or suitable abutting surfaces is permitted. Dissimilar metals should be as defined in 6.6. In hermetic seals, the 0.25 volt difference between the header material and the housing material is not applicable.

3.5.2 Magnet wire. Magnet wire shall be of such quality as to ensure that the relay meets all the performance requirements of this specification. Additional information and guidance on magnet wire is provided in 6.9.

3.6 Interface and construction requirements. Relays shall meet the interface and construction requirements (weight or physical dimensions) as specified (see 3.1).

3.6.1 Integral electromagnetic relay (class A and class B relays). For hybrid relays covered by this specification, where the time delay circuitry is external to the integral electromagnetic relay, the integral electromagnetic relay (mounting means, housing, and terminal styles excepted) shall have been tested and qualified to the following specifications, as applicable (see 3.1). For hybrid relays covered by this specification, where the time delay circuitry is contained inside the integral electromagnetic relay, the integral electromagnetic subassembly shall be similar in design and construction to, and manufactured with essentially the same materials and processes as, a family of relays that are qualified to the following specifications, as applicable (see 3.1). The integral electromagnetic subassembly shall be subjected to an unmonitored 3,000 cycle mechanical run-in at room ambient temperature in a nitrogen atmosphere prior to connection to the time delay circuitry. The cycle rate shall be 600 cycles per minute  $\pm$ 100 cycles per minute.

## MIL-PRF-83726D

Class

A ----- MIL-PRF-39016  
 B ----- MIL-PRF-83536

3.6.2 Electronic components. All active components shall be hermetically sealed or sealed in a hermetic package.

3.6.3 Case. The case shall be of sufficient mechanical strength to withstand the normal abuse incurred in handling, transit, storage, and installation without malfunction or distortion of parts.

3.6.3.1 Case grounding. The case shall not be part of the electrical circuit but it may be part of the magnetic circuit. The case, or permanent attachments thereto, shall provide a means of electrical grounding.

3.6.4 Sealing process. Hermetically sealed (non-potted) relays shall be dried, degassed, and backfilled with an atmosphere and sealed by welding such that the requirements of this specification are met. Adjunct sealant, (see 6.10), if used, must comply with the following characteristics:

- a. Shall not extend above 20 percent of the length of the exposed terminals above the glass meniscus.
- b. Trace color is permitted if it is a natural result of the sealant process.
- c. Shall form, after curing, a permanent, nonconductive, noncracking seal under all relay environments.
- d. Adjunct sealant shall only be applied to relays that have initially passed the gross leak seal requirement of this specification.

3.6.5 Enclosures.

3.6.5.1 Unsealed enclosure. Unsealed relays shall be totally enclosed for mechanical and dust protection and shall be explosion-proof. The enclosure design shall be such that pressure differentials cannot exist between the inside and outside. Metal covers shall be provided with a means for grounding as specified.

3.6.5.2 Hermetically sealed enclosure. Hermetically sealed enclosures shall be dried, degassed, and backfilled with an atmosphere and sealed such that the requirements of this specification are met.

3.6.5.3 Environmentally sealed (non-hermetic enclosures). Environmentally sealed enclosures shall be constructed by any means other than that defined under hermetically sealed enclosure (see 3.6.5.2) to achieve the degree of seal specified (see 3.1).

3.6.5.4 Grounding enclosures. The mounting shall provide an effective electrical contact to ground when the relay is mounted.

3.6.6 Threaded parts. Unless otherwise specified (see 3.1), all threaded parts shall be in accordance with FED-STD-H28. Where practical, all threads shall conform to the coarse thread series. The fine thread series shall be used only when beneficial to the application.

## MIL-PRF-83726D

3.6.7 Installation clearances. Adequate clearance shall be provided for installation of terminals and mounting hardware. Special installation tools shall not be required.

3.6.8 Contacts. Contacts shall have load ratings and arrangements (see MIL-STD-1285) as specified (see 3.1). Unless otherwise specified (see 3.1), contacts shall be capable of carrying the maximum rated current continuously as well as making and breaking the specified current under all environmental conditions specified herein.

3.6.9 Coils. Coils shall be adequately insulated electrically from the contacts and the case. The resistance and rated voltage (or current) shall be as specified (see 3.1). Unless otherwise specified (see 3.1), coils shall be designed for continuous operation at maximum rated voltage and temperature.

3.6.9.1 Coil terminal identification. Terminals identification shall be marked as specified and in accordance with MIL-STD-1285. When specified, a bead of contrasting color shall be used to designate the X1 (positive, if applicable) terminal (see figure 1 and MIL-STD-1285) (see 3.1).

3.6.10 Circuit diagram. The circuit diagram as specified shall be a terminal view. Circuit symbols shall be in accordance with ANSI Y32.2. For relays without an orientation tab, the circuit diagram, as specified (see 3.1) shall be orientated so that when the relay is held with the circuit diagram right side up (as shown), and rotated away from the viewer about a horizontal axis through the diagram until the header terminals face the viewer, each terminal shall be in the location shown in the circuit diagram.

3.6.11 Mounting means (see 3.1).

3.6.11.1 Socket. Socket plug-in relays shall be so designed that the weight of the relay will be supported and the stability of the mounting will be provided by means other than the terminals.

3.6.11.2 Bracket. Mounting brackets shall be an integral part of the relay case or shall be securely attached thereto in a manner to prevent any movement between the relay and the mounting bracket.

3.6.11.3 Mounting studs. Mounting studs shall be as specified (see 3.1). No rotation, loosening, or deformation of fixed portions shall occur because of material flow or any mechanical forces involved in installation or removal of the relay. The mounting studs shall withstand, for 1 minute without damage, the static values of pull and torque specified in table I (see 3.37). Unless otherwise specified (see 3.1), each stud shall be supplied with two flat washers, one nut, and one lockwasher. For direct Government orders, the hardware shall be assembled on the stud.

TABLE I. Strength of mounting studs (static values of pull and torque).

Thread size	Force (lbs)	Torque (lb-inches)
4-40	7	10
6-32	25	18
8-32	35	37
10-32	50	60
1/4-28	60	100
5/16-24	80	160
3/8-24	115	275
7/16-20	140	475

MIL-PRF-83726D

CONTACT ARRANGEMENTS, SYMBOLS AND TERMINAL MARKING (SEE NOTE)					
SINGLE THROW			DOUBLE THROW		
FORM "A"	FORM "B"	FORM "C"	FORM "K" SPDT	FORM "M"	
NORMALLY OPEN	NORMALLY CLOSED	(TWO POSITION)	3 POS CENTER OFF	3 POS CENTER ON	
<p>SINGLE BREAK</p>					
FORM "X"	FORM "Y"	FORM "Z"	FORM "KK"	FORM "MM"	
<p>DOUBLE BREAK</p>					

NOTE: CONTACTS ARE SHOWN WITH COIL (S) DE-ENERGIZED

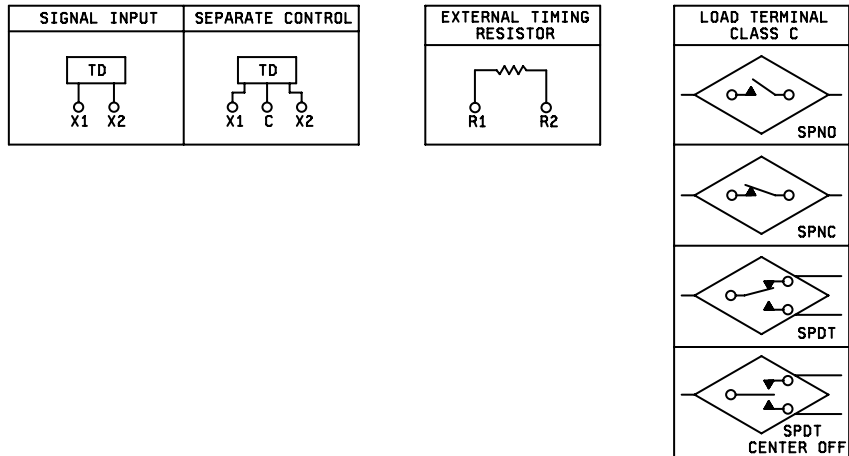

FIGURE 1. Terminal markings.

## MIL-PRF-83726D

3.6.12 Terminal (electrical). No rotation or other loosening of a terminal, or any fixed portion of a terminal, shall be caused by material flow or shrinkage, or any mechanical forces specified in [table II](#) involved in connection or disconnection, throughout the life of the relay. Unless otherwise specified (see [3.1](#)), terminals shall be marked or be adequately described by the circuit diagram in accordance with [MIL-STD-1285](#) and [table II](#).

TABLE II. Strength of terminals (static value of pull and torque).

Thread size	Force (lbs)	Torque (lb-inches)
4-40	5	4.4
6-32	30	10.0
8-32	35	20.0
10-32	40	32.0
10-24	40	35.0
1/4-28	50	75.0
5/16-24	70	100.0
3/8-24	100	150.0
7/16-20	100	150.0
1/2-20	100	150.0

3.6.12.1 Solder-lug, plug-in, and printed-wiring terminals.

3.6.12.1.1 Solder-lug terminals. Unless otherwise specified (see [3.1](#)), solder-lug terminals may be of any shape, and shall be capable of being readily soldered. Solder-lug terminals shall be designed to accommodate two #20 stranded wires with 19 strands for relays rated for 2 A and less, and two wires, each rated to carry the maximum rated current of the relay, for relays rated above 2 A. Input terminals to the time delay circuitry shall be designed to accommodate two #20 stranded wires with 19 strands. Unless otherwise specified (see [3.1](#)), solder-lug terminals shall not be gold plated.

3.6.12.1.2 Plug-in terminals. Plug-in terminals shall conform to the arrangements or dimensions necessary for proper mating with the associated connectors or sockets as specified (see [3.1](#)). The mounting arrangement of the relay and its corresponding socket shall be so designed that the entire weight of the relay will be suspended and the stability of its mounting will be provided by an auxiliary mounting means other than the electrical terminals of the socket. Relays with plug-in terminals shall have electrical and environmental tests of section 4 performed with the appropriate or specified socket or connector assembled to the relay.

3.6.12.1.3 Printed-wiring terminals. Printed-wiring terminals shall be spaced in multiples of .050 inch (1.27 mm) for compatibility with printed-wiring grid spacing.

3.6.12.1.4 Strength of solder-lug, plug-in, printed wiring, and wire lead terminals. The relay terminals shall be designed to withstand the applicable terminal strength performance procedure specified in [3.36](#).

3.6.12.2 Terminal finish. Finish of terminals shall provide a good electrical contact and meet the performance requirements specified herein.

3.6.12.3 Solder dip (retinning) terminals. The manufacturer may solder dip/retin the terminals of product



## MIL-PRF-83726D

supplied to this specification provided the solder dip process has been approved by the qualifying activity (see [appendix A](#)).

3.7 Screening (see [4.7.2](#)). Relays shall be tested as specified in [4.7.2](#) at -55°C, +25°C, and +125°C.

3.8 Solderability (not applicable to plug-in relays) (see [4.7.32](#)). The critical (examination) area dipped portion of the terminals shall conform to the inspection requirements as specified in [4.7.32](#).

3.9 Seal (see [4.7.3](#)).

3.9.1 Hermetic seal. The leakage rate shall not exceed  $1 \times 10^{-6}$  atmospheric cubic centimeters per second of net sealed gas volume for relays greater than 2 cubic inches volume. For relays of 2 cubic inches volume or less, the leakage rate shall not exceed  $1 \times 10^{-8}$  atmospheric cubic centimeters per second of air.

3.9.2 Environmental seal. The leakage rate shall be as specified (see [3.1](#)).

3.10 Dielectric withstanding voltage (DWV) (see [4.7.4](#)). There shall be no leakage current in excess of 1.0 mA.

3.11 Insulation resistance (IR)(see [4.7.5](#)). The IR shall be not less than 1,000 megohms. Following resistance to soldering heat, thermal shock, shock vibration (high frequency), acceleration, moisture resistance, and after all life tests, the IR shall be not less than 500 megohms.

3.12 Static contact resistance, contact voltage drop, and output voltage drop (see [4.7.6](#)). Unless otherwise specified (see [3.1](#)), the contact voltage drop or the output voltage drop shall not exceed the applicable values specified in table III. When applicable, the contact resistance shall be as specified (see [3.1](#)).

TABLE III. Contact voltage drop.

Class	Reading - Before life test		Reading - After life test	
	Average	Maximum individual	Average	Maximum individual
A	$\frac{V_{dc}}{0.100}$	$\frac{V_{dc}}{0.100}$	$\frac{V_{dc}}{0.200}$	$\frac{V_{dc}}{0.200}$
B	0.150	0.175	0.175	0.200
C	1.5	2.5	1.5	2.5

3.13 Leakage current (class C relays) (see [4.7.7](#)). The leakage current shall not exceed the maximum value specified (see [3.1](#)).

3.14 Input current (see [4.7.8](#)). The input and control current, if applicable, exclusive of the output load shall not exceed the value specified (see [3.1](#)).

3.15 Waveform distortion (class C, ac relays) (see [4.7.9](#)). The output waveform distortion shall not exceed the limits specified (see [3.1](#)).

## MIL-PRF-83726D

3.16 DC offset voltage (class C, ac relays) (see 4.7.10). The dc offset voltage shall not exceed the value specified (see 3.1).

3.17 Current range (class C, ac relays) (see 4.7.11). Unless otherwise specified, the dc offset voltage and waveform distortion shall not exceed specified values for all load current between 1 percent and 100 percent of relay rating.

3.18 Zero crossover (class C, ac relays) (see 4.7.12). Relay turn-on shall occur at the zero voltage crossover  $\pm 6$  V, and relay turn-off shall occur at the zero current crossover  $\pm$  rated load  $\times 10^{-2}$  (maximum). Relays shall turn-off at the opposite half-cycle from turn-on.

3.19 Bias current (when applicable) (class C relays) (see 4.7.13). When relays are tested as specified in 4.7.13, The bias current shall not exceed the value specified (see 3.1).

3.20 Maximum deactuation voltage (class C relays) (see 4.7.14). The maximum deactuation voltage shall not be greater than that specified (see 3.1).

3.21 Transients (see 4.7.15).

3.21.1 Voltage (surge) (see 4.7.15.1). Relays shall withstand the application of transient voltage without damage or effect on the delay period (beyond specified tolerances) within the timing cycle specified (see 3.1).

3.21.2 Susceptibility (spike) (see 4.7.15.2). Relays shall not malfunction or be damaged. Following the test, the timing cycle and recycle time shall be as specified in 3.22 and 3.23, respectively.

3.21.3 Susceptibility, extraneous voltage (applicable to type IIA) (see 4.7.15.3). Relays shall not operate over the specified temperature range (see 3.1) when 25 percent of the nominal control voltage (see 3.1) is applied to the control terminals.

3.21.4 Self-generated (spike) (see 4.7.15.4). Relays shall not generate transient voltages in excess of those specified (see 3.1).

3.22 Timing cycle (see 4.7.16). All switching circuits shall make positive contact or open as applicable. The timing cycle, period, interval, or sequence shall be within the tolerance specified (see 3.1). There shall be no momentary change in output state if the input voltage is removed prior to the end of the timing cycle. Removal of the input voltage shall reset the relay for the next operation, within the reset time specified. For type I, IIA, and type IIB, relays, when minimum or maximum rated operating voltage is applied to the input terminals, the relay must operate within the time interval specified. When the voltage is removed, the relay shall return to the deenergized condition within the time interval specified. Type IIA relays shall not operate or remain operative when the control voltage is applied and the operate voltage removed. Type III relays, when minimum or maximum rated operating voltage is applied to the input terminals, must operate and return to the deenergized condition within the time interval specified. Type IV and type V relays switching circuits, when minimum or maximum voltages are applied to the input terminals, must operate in accordance with the timing cycles and tolerances specified (see 3.1).

3.23 Recycle time (see 4.7.17). Relays shall repeat normal operation and the timing cycle shall be as specified in 3.22. For type III relays, removal of input voltage shall reset the time delay relay for the next operation, within the reset time specified.

3.24 Reverse polarity (dc operated relays) (see 4.7.18). Relays shall not operate, start timing, or be

## MIL-PRF-83726D

damaged. Following the test, the timing cycle and recycle time shall be as specified in 3.22 and 3.23, respectively (at 23°C only).

3.25 Electromagnetic interference (see 4.7.19). Relays shall not create nor be susceptible to electromagnetic interference in excess of the limits specified in MIL-STD-461, class ID.

3.26 Crosstalk (when specified, see 3.1) (see 4.7.20). Unless otherwise specified, the attenuation shall be a minimum of 20 dB.

3.27 Capacitance (when specified see 3.1) (see 4.7.21). The capacitance shall not exceed the values specified (see 3.1).

3.28 Continuous current (see 4.7.22). Relays shall remain operative and there shall be no damage. Following the test, DWV, IR, contact voltage drop (or resistance), timing cycle, and recycle time shall be as specified in 3.10, 3.11, 3.12, 3.22 and 3.23, respectively.

3.29 Resistance to soldering heat (not applicable to plug-in relays) (see 4.7.23). Following the test, there shall be no damage to the relay and the DWV, IR, timing cycle at 23°C, and recycle time at 23°C, shall be as specified in 3.10, 3.11, 3.22 and 3.23, respectively.

3.30 Salt spray (corrosion) (see 4.7.24). Following washing in cold running tap water and drying for 6 hours at 65°C, the relays shall show no evidence of corrosion sufficient to impair the operation of the relay. Following this test, the timing cycle and recycle time shall be as specified in 3.22 and 3.23.

3.31 Thermal shock (see 4.7.25). There shall be no damage to the relay, loosening of terminals, or cracking or flaking of glass insulation (other than crazing or chipping of the glass meniscus). Following the test, the DWV, IR, contact voltage drop (or resistance), timing cycle, and recycle time shall be as specified in 3.10, 3.11, 3.12, 3.22, and 3.23, respectively.

3.32 Low temperature operation (see 4.7.26). There shall be no damage to the relay, loosening of terminals, cracking or flaking of glass insulation (other than crazing or chipping of the glass meniscus) or of the hermetic seal. Following the test and at the specified low temperature, timing cycle, recycle time, and contact voltage drop shall meet the requirements of 3.22, 3.23, and 3.12, respectively, and shall continue to meet timing cycle and recycle time requirements until the relay returns to room temperature.

3.33 Shock (specified pulse) (see 4.7.27). Relays shall meet the following requirements, as applicable:

- a. Class A and class B relays: Unless otherwise specified (see 3.1), there shall be no closing of open contacts nor opening of closed contacts in excess of 10 microseconds ( $\mu$ s).
- b. All relays: Following the test, there shall be no structural failure, and the timing cycle and recycle time shall be as specified in 3.22 and 3.23, respectively.

3.34 Vibration, high frequency (see 4.7.28). Relays shall meet the following requirements, as applicable:

- a. Class A and class B relays: Unless otherwise specified (see 3.1), there shall be no closing of open contacts nor opening of closed contacts in excess of 10  $\mu$ s.
- b. All relays: Following the test, the DWV, IR, contact voltage drop (or resistance), timing cycle, and recycle time shall be as specified in 3.10, 3.11, 3.12, 3.22, and 3.23, respectively.

## MIL-PRF-83726D

3.35 Acceleration (class A and class B relays) (see 4.7.29). The contacts shall remain in the deenergized condition with no input voltage, and the timing cycle and recycle time shall be as specified in 3.22 and 3.23, respectively.

3.36 Resistance to solvents (see 4.7.30). The marking shall remain legible.

3.37 Strength of terminals and mounting studs (see 4.7.31).

3.37.1 Strength of threaded terminals and mounting studs (see 4.7.31.1). Relays having threaded stud type terminals or stud type mounting shall be tested to determine compliance with terminal strength design requirements specified in 3.6.11.3 and 3.6.12.1.4. The terminals shall not loosen or rotate, nor shall there be any other damage such as cracking or flaking of glass insulator other than crazing or chipping of the glass meniscus. There shall be no deterioration of relay performance beyond limits specified (see 3.1).

3.37.2 Strength of solder-lug, plug-in, and wire-lead terminals (see 4.7.31.2). There shall be no loosening or breakage of terminals, cracking or flaking of glass insulators other than crazing or chipping of the glass meniscus, or any other damage that would affect relay performance beyond specified limits.

3.38 Overload (class C, when specified) (see 4.7.33). There shall be no electrical failure. The contact miss detector's monitoring level for monitoring voltage drop across closed contacts shall be less than 10 percent of the applied load voltage and the monitoring level for monitoring voltage drop across open contacts shall be 90 percent, or more, of the applied load voltage. The case-to-ground fuse shall remain electrically continuous. Following the test, the timing cycle and recycle time shall be as specified in 3.22 and 3.23, respectively. Relays indicating failure, but not verified per a failure verification procedure approved by the qualifying activity, may be returned to test.

3.39 Life (see 4.7.34). Phase-to-phase arcing; failure of the contacts to make (see note), carry, or break the load; or failure of the fuse connected between case and load system ground or neutral shall constitute a failure. For high level testing, the contact miss detector's monitoring level for monitoring voltage drop across closed contacts shall be less than 10 percent of the applied load voltage and the monitoring level for monitoring voltage drop across open contacts shall be 90 percent, or more, of the applied load voltage. Following each life test, the DWV, IR, contact voltage drop (or resistance), timing cycle, and recycle time shall be as specified in 3.10, 3.11, 3.12, 3.22 and 3.23, respectively. Class A and class B time delay relays shall be tested at highest rated system voltage and resistive load current rating. Use of a qualified electromechanical relay with equivalent ratings will be evidence of meeting life requirements at other ratings. Class C relays shall be tested at each contact load specified. (Monitoring of terminal temperature rise applicable to qualification and group C testing only). If the lamp load is equal to or less than 0.5 times the motor load rating, the lamp load test need not be run. Terminal temperature rise shall not exceed 75°C. Relays indicating failure, but not verified per a failure verification procedure approved by the qualifying activity, may be returned to test.

NOTE: "Fail to make" shall be defined as a voltage drop across the contacts or output exceeding 10 percent of full rated voltage.

3.40 Low level (when specified, see 3.1) (see 4.7.34.2). For low level testing, the contact miss detector's monitoring level shall be less than or equal to 100 ohms and the dynamic contact resistance shall not exceed 100 ohms more than once per 100,000 operations (cumulative). There shall be no mechanical failures nor erratic operation. The case-to-ground fuse shall remain electrically continuous. Following the test, the DWV, IR, contact voltage drop (or resistance), timing cycle, and recycle time shall be as specified in 3.9, 3.10, 3.11, 3.21 and 3.22, respectively. Relays indicating failure, but not verified per a failure verification procedure approved by the qualifying activity, may be returned to test.

## MIL-PRF-83726D

3.41 Vibration scan (see 4.7.34). When subjected to one cycle of vibration scan, there shall be no contact chatter in excess of 10  $\mu$ s.

3.42 Marking.

3.42.1 "JAN" and "J" marking. The United States Government has adopted and is exercising legitimate control over the certification marks "JAN" and "J", respectively, to indicate that items so marked or identified are manufactured to, and meet all the requirements of specifications. Accordingly, items acquired to, and meeting all of the criteria specified herein and in applicable specifications shall bear the certification mark "JAN" except that items too small to bear the certification mark "JAN" shall bear the letter "J". The "JAN" and "J" shall be placed immediately before the part number except that if such location would place a hardship on the manufacturer in connection with such marking, the "JAN" or "J" may be located on the first line above or below the part number. Items furnished under contracts or orders which either permit or require deviation from the conditions or requirements specified herein on in applicable specifications shall not bear "JAN" or "J". In the event an item fails to meet the requirements of this specification and the applicable specification sheets, the manufacturer shall remove completely the military part number and the "JAN" or the "J" from the sample tested and also from all items represented by the sample. The "JAN" or "J" certification mark shall not be used on products acquired to contractor drawings or specifications. The United States Government has obtained Certificate of Registration Number 504,860 for the certification mark "JAN" and Registration Number 1,586,261 for the certification mark "J".

3.42.2 Identification marking (full). Relays shall be marked in accordance with method I of [MIL-STD-1285](#) and shall include the following information:

- a. PIN (see [1.2.2](#) and [3.1](#)). The "JAN" or "J" shall not be marked in front of the PIN.
- b. "JAN" or "J" brand. The "JAN" or "J" shall appear directly above or below the "M" of the PIN.
- c. Date code (at the option of the relay manufacturer the "J" with the date code may be used instead of [3.41.2b](#)). The date code shall provide traceability (see [4.4.1.1](#)).
- d. Source code.
- e. Lot symbol (optional).
- f. Rated coil voltage (or current) (see [3.1](#)) and when applicable, operating frequency.
- g. Coil resistance.
- h. Contact rating (the highest dc resistive load rating shall be marked) (see [3.1](#))
- i. Circuit diagram (see [3.6.10](#)).
- j. Terminal marking (when applicable, see [3.1](#), [3.6.9.1](#), and [3.6.12](#)).

3.43 Header glass. Header glass may have small irregularities, such as bubbles, chips, and cracks. The acceptability shall be based upon [figure 2](#) and the following:

- a. Surface blisters whose diameters do not exceed one half of the radial distance between the terminal and the corresponding header metal (for a cluster of blisters, the overall cluster diameter shall apply) are acceptable

MIL-PRF-83726D

- b. Circumferential cracks which originate and terminate in the glass and which extend less than 135 degrees are acceptable (see [figure 2](#), reference B).
- c. Radial cracks with lengths not exceeding three quarters of the distance between the terminal and the surrounding header metal are acceptable (see [figure 2](#), reference C).
- d. Tangential cracks which are confined to a single zone are acceptable (see [figure 2](#), reference D).
- e. Meniscus cracks or chipouts which completely surround the terminal are acceptable if:
  - (1) The meniscus cracks or chipouts do not extend beyond one half the distance from the terminal to the surrounding header metal, or
  - (2) The meniscus cracks or chipouts do not extend beyond one quarter of the distance to the surrounding header metal and a portion of the meniscus cracks or chipouts do not extend beyond three quarters of the distance from the terminal to the surrounding header metal if that portion of the meniscus cracks or chipouts do not span more than 180 degrees (see [figure 2](#), reference E).
- f. An internal bubble whose diameter does not exceed one third of the distance between the terminal and the surrounding header metal is acceptable.

Microscopic examination with up to 10X magnification shall be used. In case of dispute, all relays shall meet the applicable DWV, IR, and seal requirements, regardless of the acceptability of the glass.

## MIL-PRF-83726D

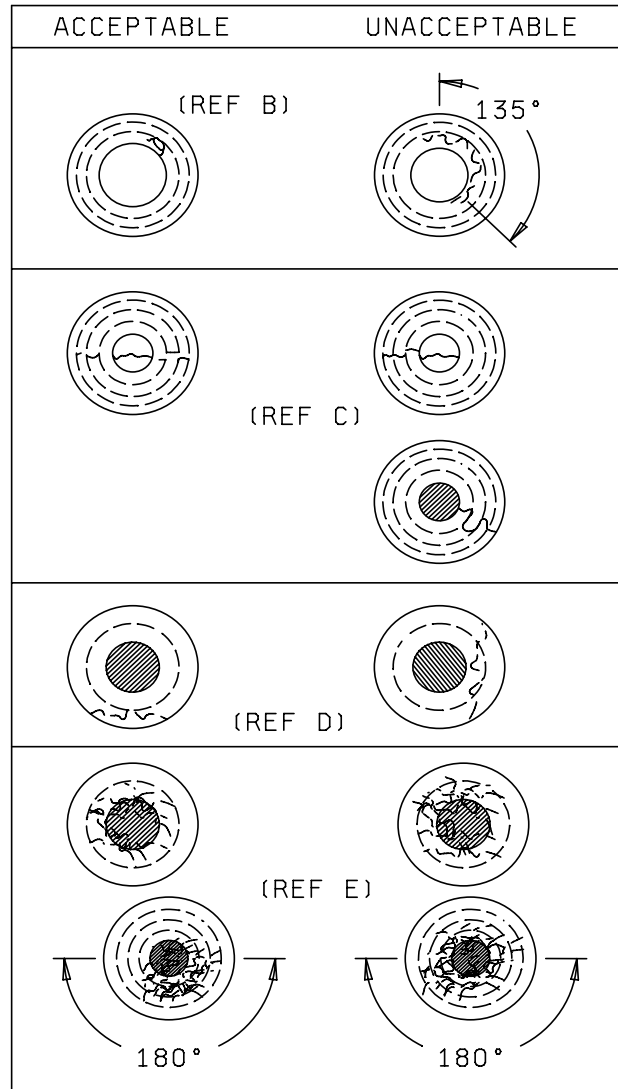

NOTE: The broken lines indicate the division of the radial distance between the terminal and the surrounding header metal into equal parts, thus creating concentric zones around the terminal.

FIGURE 2. Inspection aid.

## MIL-PRF-83726D

3.44 Recycled, recovered, or environmentally preferable materials. Recycled, recovered, or environmentally preferable materials should be used to the maximum extent possible, provided that the material meets or exceeds the operational and maintenance requirements, and promotes economically advantageous life cycle costs.

3.45 Workmanship. Relays shall be fabricated in such a manner as to be uniform in quality, and shall be free from cracked or displaced parts, sharp edges, burrs, and other defects that will affect life, serviceability, and appearance.

#### 4. VERIFICATION

4.1 Classification of inspection. The inspections specified herein are classified as follows:

- a. Qualification inspection (see 4.2).
- b. Verification of qualification (see 4.6).
- c. Conformance and periodic inspections (see 4.3).

4.2 Qualification inspection. Qualification inspection shall be performed at a laboratory acceptable to the Government (see 6.3) on sample relays produced with equipment and procedures normally used in production. Variables measurements are acceptable.

4.2.1 Qualification. Evidence of compliance to the material requirements of 3.5 and the interface and construction requirements of 3.6 shall be provided to the qualifying activity in conjunction with the qualification inspection results. As a part of qualification or qualification after redesign, electrostatic discharge sensitivity testing shall be done in accordance with method 3015 of MIL-STD-883 modified to test at 16,000 V. Testing at lower voltage levels is not required.

4.2.1.1 Sampling plan. The number of relays to be subjected to qualification inspection shall be as specified in table IV. The sample shall be selected from a production run and shall be produced with equipment or procedures normally used in production. The qualification sample shall be defined in table IV.

4.2.1.2 Inspection routine. Sample units shall be subjected to the qualification inspection as specified in table IV. All sample units shall be subjected to the tests in Q1. These sample units shall then be divided into four groups as specified in table IV and subjected to the inspection specified for their particular group (Q2 through Q4). Groups Q2 through Q4 may be conducted concurrently.

4.2.1.3 Failures. Failures in excess of those allowed in table IV shall be cause for refusal to grant qualification approval.

#### 4.3 Conformance inspections.

4.3.1 Conformance inspection. Conformance inspection shall consist of the group A inspection.

##### 4.3.1.1 Inspection and production lot.

4.3.1.1.1 Inspection lot. An inspection lot shall consist of relays covered by a single specification sheet, manufactured under essentially the same processes and conditions during a manufacturing period of 1 month maximum. The manufacturer shall define and document the period for an inspection lot. For purposes of lot formation, all terminal types and mounting configurations may be combined.



## MIL-PRF-83726D

4.3.1.1.2 Production lot. A production lot shall consist of relays of the same part number. Manufacture of all parts in the lot shall have been started, processed, assembled, and tested as a group. Lot identity shall be maintained throughout the manufacturing cycle.

4.3.1.2 Group A inspection. Group A inspection shall consist of the inspections specified in [table V](#).

4.3.1.2.1 A1, A2, and A4 tests. The A1, A2, and A4 tests shall be performed on a production lot basis on 100 percent of the product supplied under this specification.

4.3.1.2.1.1 Sampling plan. The tests in A1, A2, and A4 shall be performed on each relay offered for inspection, except as noted. Testing shall proceed in sequence from A1 through A4. However, testing sequence is optional in group A2 except that DWV and IR shall be tested prior to timing cycle and recycle time.

4.3.1.2.1.2 Noncompliance. Relays which have failed to pass group A inspection shall be removed from the lot. Alternatively, the group A failures may be reworked, or have parts replaced, to correct the defects and then be resubmitted to group A inspection for acceptance. Relays that do not pass group A inspection after rework/replacement shall not be delivered on the contract or purchase order.

4.3.1.2.2 A3 tests.

4.3.1.2.2.1 Sampling plan. Two samples, as applicable, shall be randomly selected from each inspection lot and subjected to the A3 solderability test. If there are one or more defects, the lot shall be considered to have failed. Relays failing the A2 electrical tests, or rejected for other criteria which will not influence solderability, may be used for solderability testing. All rejected relays used as samples must accompany the acceptable relays through all processing environments. The rejected relays shall be marked in a definite manner in order to preclude mixing with acceptable parts.

4.3.1.2.2.2 Rejected lots. In the event of one or more defects, the inspection lot is rejected. The manufacturer may use one of the following options to rework the lot:

- a. Each production lot that was used to form the failed inspection lot shall be individually submitted to the solderability test as required by [4.7.32](#). Production lots that pass the solderability test are acceptable for shipment. Production lots failing the solderability test can be reworked as described in [4.3.1.2.2.2b](#) or [4.3.1.2.2.2c](#).
- b. The manufacturer submits the failed lot to 100 percent solder dip using an approved solder dip process in accordance with A.3.1 of appendix A. Two additional samples shall be selected and subjected to the solderability test with zero defects allowed. If the lot fails this solderability test, the lot shall be rejected and shall not be furnished against the requirements of this specification.
- c. The manufacturer may submit the failed lot to a strip and replate process followed by a complete group A inspection. If the lot fails this solderability test, the lot shall be rejected and shall not be furnished against the requirements of this specification.

4.3.2 Periodic inspections. Periodic inspection shall consist of the tests in the order specified in [table VI](#), and shall be made on sample units from inspection lots which have passed the group A inspection.

4.3.2.1 Group B inspection. Group B inspections shall consist of the tests in the order specified in [table VI](#), and shall be made on sample units from inspection lots which have passed the group A inspection.

## MIL-PRF-83726D

4.3.2.1.1 Sampling plan. Sample selection for group B shall be made on lots which have passed group A inspection (inspection lot). The number of samples selected for testing shall be in accordance with the following schedule:

<u>Total production of all inspection lots</u>	<u>Sample size</u>
0	0
1 to 100	1
Each additional 500	1

This plan shall be performed for all production during the retention period, with reports submitted to the qualifying activity annually. In the event no production occurs for the year, a statement of no production shall be provided to the qualifying activity.

4.3.2.1.2 Disposition of sample relays. Sample relays which have been subjected to group B inspection shall not be delivered on the contract or purchase order.

4.3.2.2 Group C inspection. Group C inspection shall consist of the tests in the order specified in table VII, and shall be made on sample units from inspection lots which have passed the group A inspection.

4.3.2.2.1 Sampling plan. Two sample units shall be taken from production for C1 every 36 months, two samples for C2 every 36 months, and two samples for C3, every 36 months. No failures shall be permitted.

4.3.2.2.2 Disposition of sample units. Sample units which have been subjected to group C inspection shall not be delivered on the contract or purchase order.

4.3.2.3 Noncompliance. If a sample fails to pass group B or group C inspection, the manufacturer shall notify the qualifying activity and the cognizant inspection activity of such failure within 5 working days. The manufacturer shall prepare to take corrective action on the materials or processes, or both, as warranted, and on all units of product which can be corrected and which are manufactured under essentially the same processes with essentially the same materials, and which are considered subject to the same failure. Acceptance and shipment of the product shall be discontinued until corrective action, acceptable to the qualifying activity, has been taken. In the event of a single isolated failure on group B testing, and if the relay in question satisfactorily completed 50 percent of the specified minimum cycles on the particular load being tested, the manufacturer may elect the option to select an additional three relays for the same group B testing. The successful completion of group B testing on all three relays may be submitted to the qualifying activity as evidence of a random isolated failure with no further corrective action. Otherwise, after the corrective action has been taken, group B or group C inspection shall be repeated on additional sample units (all tests and examinations, or the test which the original sample failed, at the option of the qualifying activity). Group A inspection may be reinstated; however, final acceptance and shipment shall be withheld until the group C inspection has shown that the corrective action was successful.

4.4 QPL system. The manufacturer shall establish and maintain a QPL system as described in 3.5. Evidence of such compliance shall be verified by the qualifying activity of this specification as a prerequisite for qualification and retention of qualification.

4.4.1 SPC. The manufacturer shall establish and maintain an SPC program as described in 3.4.1. Evidence of such compliance shall be verified by the qualifying activity as a prerequisite for qualification and retention of qualification.

MIL-PRF-83726D

4.4.1.1 Traceability requirements. The manufacturer shall have a procedure whereby the lot date codes are assigned that incorporates traceability. The following is a list of raw material/component parts and subassembly traceability requirements:

a. Relay/relay subassembly.

- (1) Stationary or moving contact (a contact may consist of an individual blade or a blade and a contact button).
- (2) Header with glass to metal sealed leads in place with the lot number.
- (3) Return spring(s).
- (4) Diodes (when applicable) with the lot number.
- (5) Magnets (when applicable).
- (6) Wound coils with lot number.
- (7) Armature assembly.

b. Electronic or hybrid assembly.

Electronic components.

4.4.2 ESDS protection program. This requirement is applicable to all manufacturers who handle ESDS component parts or materials in the relay manufacturing or testing process (see [3.5.2](#)). Evidence of such compliance shall be verified by the qualifying activity of this specification as a prerequisite for qualification and continued qualification.

## MIL-PRF-83726D

TABLE IV. Qualification inspection.

Inspection	Requirement paragraph	Test method paragraph	Number of sample units to be inspected	Number of failures allowed
<u>Q1</u>		4.7.2		
Screening	3.7			
Visual and mechanical inspection:				
Internal - (1 unsealed unit)	3.1, 3.5, 3.6, 3.45	4.7.1.1		
External - (dimensional check on 2 sample units only)	3.1, 3.5, 3.6, 3.42, 3.45, and 3.45	4.7.1.2		
Solderability (3 sample units) <u>1/</u>	3.8	4.7.32		
DWV	3.10	4.7.4		
IR	3.11	4.7.5	All sample units	0
Contact (output) voltage drop or resistance	3.12	4.7.6		
Leakage current <u>2/</u>	3.13	4.7.7		
Input current	3.14	4.7.8		
Waveform distortion (ac relays) <u>2/</u>	3.15	4.7.9		
DC offset voltage (ac relays) <u>2/</u>	3.16	4.7.10		
Current range (ac relays) <u>2/</u>	3.17	4.7.11		
Zero crossover (ac relays) <u>2/</u>	3.18	4.7.12		
Bias current (when applicable) <u>2/</u>	3.19	4.7.13		
Maximum deactuation voltage <u>2/</u>	3.20	4.7.14		
Transients	3.21	4.7.15		
Timing cycle	3.22	4.7.16		
Recycle time	3.23	4.7.17		
Reverse polarity (dc operated)	3.24	4.7.18		
Seal	3.9	4.7.3		
<u>Q2</u>				
Electromagnetic interference	3.25	4.7.19		
Crosstalk (when specified)	3.26	4.7.20		
Capacitance (when specified)	3.27	4.7.21		
Continuous current	3.28	4.7.22	4	1
Resistance to soldering heat (not applicable to plug-in relays)	3.29	4.7.23		
Salt spray	3.20	4.7.24		
Seal	3.9	4.7.3		

See footnotes at end of table.

## MIL-PRF-83726D

TABLE IV. Qualification inspection - Continued.

Inspection	Requirement paragraph	Test method paragraph	Number of sample units to be inspected	Number of failures allowed
<u>Q3</u>				
Thermal shock	3.31	4.7.25	4	1
Low temperature operation	3.32	4.7.26		
Shock (specified pulse)	3.33	4.7.27		
Vibration, high frequency	3.34	4.7.28		
Acceleration <u>3/</u>	3.35	4.7.29		
Resistance to solvents	3.36	4.7.30		
Strength of terminals and mounting studs	3.37	4.7.31		
Seal	3.9	4.7.3		
<u>Q4</u>				
Overload	3.38	4.7.33	4	1
Life <u>4/</u>	3.39	4.7.34		
Seal	3.9	4.7.3		

- 1/ The solderability samples may be three additional samples selected solely for solderability testing. The three samples shall accompany the rest of the qualification samples through Q1 screening prior to selection as solderability samples. The solderability samples need not be used as samples for Q2, Q3, or Q4 tests.
- 2/ Class C only.
- 3/ Not applicable for class C.
- 4/ One sample unit required for each load rating for class C.

4.5 Inspection conditions. Unless otherwise specified herein, the test conditions specified in the "GENERAL REQUIREMENTS" of MIL-STD-202 shall be considered for referee purposes only. All inspections may be performed at ambient conditions consistent with industry practice.

4.5.1 Power supply. Unless otherwise specified herein, the power supply shall have no more than 10 percent regulation at 110 percent of the specified test load current. A dc power supply shall have no more than 5 percent ripple voltage. An ac power supply shall be within 1 percent of the specified frequency and shall be sinusoidal with a form factor between 0.95 and 1.25.

4.5.2 Grounding. Unless otherwise specified (see 3.1), the negative side of the dc power supply shall be grounded. One side of the single-phase ac power supply shall be grounded. Neutral of the three-phase ac power supply shall be grounded.

4.5.3 Load conditions during test. The coil of the relay being tested shall be connected to the grounded side of their power supply; the loads of the relay being tested shall be connected to the grounded side of their power supply; and each stationary contact shall be connected to an individual load or, as an option, to the loads of the relay. All tests during which the contacts are loaded and being cycled, except DWV, shall be conducted with the case of the relay connected to the power supply ground or neutral through a normal blow fuse rated at five percent of the contact load maximum, but not less than 100 mA. For relays with nongrounded case ratings, tests for isolated-case ratings may be made with the case electrically isolated from the power supply ground.

MIL-PRF-83726D

4.5.4 Testing devices. Unless otherwise specified, devices used in the testing of relays shall not load the contacts above 10 mA resistive at 6 V or peak ac maximum open circuit voltage.

4.5.5 Temperatures. Relays shall be tested at an ambient temperature of -55°C, +25°C, and +125°C, and the conformance inspection (see 4.3), may be conducted at the specified temperatures. Temperatures are ambient and not case.

4.5.6 Wire. In any of the specified load tests (see 4.7.33 and 4.7.34), each individual wire shall be a minimum of 3 feet in length and of an applicable size conductor (copper) for use in free air as determined by the rated resistive load of the relay. If the relay rating does not coincide with wire size, the next larger diameter wire shall be used.

4.5.7 Terminal lugs. Wire shall be terminated with an applicable size and type of terminal lug such that the performance requirements of this specification are met.

## MIL-PRF-83726D

TABLE V. Group A inspection. 1/

Inspection	Requirement paragraph	Test method paragraph	Inspection requirements
<u>A1</u> <u>2/</u>			
Screening	3.7	4.7.2	100 percent
<u>A2</u>			
DWV	3.10	4.7.4	
IR	3.11	4.7.5	
Contact (output) voltage drop or resistance	3.12	4.7.6	
Leakage current	3.13	4.7.7	
Input current	3.14	4.7.8	
Waveform distortion (ac relays)	3.15	4.7.9	
DC offset voltage (ac relays)	3.16	4.7.10	
Current range (ac relays)	3.17	4.7.11	100 percent
Zero crossover (ac relays)	3.18	4.7.12	
Bias current (when applicable)	3.19	4.7.13	
Maximum deactuation voltage	3.20	4.7.14	
Reverse polarity (dc operated)	3.24	4.7.18	
Timing cycle	3.22	4.7.16	
Recycle time	3.23	4.7.17	
<u>A3</u>			
Solderability	3.8	4.7.32	2 samples
<u>A4</u>			
Visual and mechanical inspection (external) <u>3/</u>	3.1, 3.5, 3.42, 3.45	4.7.1.3	100 percent
Seal	3.9	4.7.3	

1/ Tests shall be performed in the sequence shown by group (A1, A2, A3, then A4), except that groups A3 and A4 may be performed concurrently if the sample units for A3 are not shippable product. Testing in A2 may be performed in any sequence.

2/ Class C only.

3/ Minor defects, such as marking, may be reworked. It is intended that a two piece sample of each relay style be inspected in accordance with 4.7.1.3, except as limited by housing style or external attachments.

4.5.8 Attitude. Unless otherwise specified, the qualification inspection (see 4.2), shall be conducted with the relay mounted in the position most likely to cause malfunctioning. This position shall be shown or otherwise noted in test papers.

## MIL-PRF-83726D

4.5.9 Altitude-temperature tests. Unless otherwise specified, the relay under test shall be surrounded by a metal enclosure, the surface of which is established at the specified high temperature. The enclosure inner shall have an emissivity between 0.7 and 1.0 for the test temperature employed. The air within the test enclosure shall be still and held at the specified altitude. The relay may be mounted by its normal mounting means on a metal plate maintained at the temperature of the chamber walls.

TABLE VI. Group B inspection.

Inspection	Requirement paragraph	Test method paragraph
Input current	3.14	4.7.8
Reverse polarity (dc operated relays)	3.24	4.7.18
Transients	3.21	4.7.15
Thermal shock	3.31	4.7.25
Vibration, scan	3.41	4.7.35
Life (classes as applicable) <u>1/</u> <u>2/</u>	3.39	4.7.34
Resistive	3.39	4.7.34.1.1
Inductive	3.39	4.7.34.1.2
Lamp	3.39	4.7.34.1.3
Motor current (ac or dc)	3.39	4.7.34.1.4, 4.7.34.1.5
Seal	3.9	4.7.3

1/ Sample unit shall be tested in a predetermined sequence as defined by the manufacturer and approved by the qualifying activity. All loads specified in the applicable specification sheet shall be represented. All loads need not be represented in a 12-month maintenance period, but shall be represented within three 12-month maintenance periods.

2/ When 115/200 V ac, three phase testing is specified, 115 V ac one-phase testing is not required.

4.5.10 Methods of examination and test. Application of coil power to relays under test shall be such that plus polarity is applied to the color coded terminal when applicable; or to the lower numbered terminal when color coding is not used.

4.5.11 Tolerances. Unless otherwise specified (see 3.1), all electrical, environmental, and mechanical parameters shall have a tolerance of  $\pm 10$  percent.

4.5.12 Alternate test equipment. Test circuits and test equipment specified herein are intended to provide guidance to the relay manufacturer. Use of any alternate test circuits or test equipment shall be approved by the qualifying activity prior to use.

4.6 Verification of qualification. To retain qualification, every 12 months the manufacturer shall provide verification of the following requirements:

- a. MIL-STD-790 program.
- b. Design of the relay has not been modified.



## MIL-PRF-83726D

- c. The specification requirements for the item have not been amended so as to affect the character of the item.
- d. Periodic group B and C inspection have been performed as specified.

TABLE VII. Group C inspection.

Inspection	Requirement paragraph	Test method paragraph	Number of sample units for inspection
<u>C1 (every 36 months)</u>			
Continuous current	3.28	4.7.22	2
<u>C2 (every 36 months)</u>			
Life (classes as applicable) Resistive, dc (1 relay) Resistive, ac (1 relay)	3.39	4.7.34	2
<u>C3 (every 36 months)</u>			
Resistance to soldering heat (not applicable to plug-in relays)	3.29	4.7.23	
Salt spray (corrosion)	3.30	4.7.24	
Thermal shock	3.31	4.7.25	
Shock (specified pulse)	3.33	4.7.27	
Vibration, high frequency	3.34	4.7.28	
Acceleration (class A and class B relays)	3.35	4.7.29	2
Strength of terminals and mountings studs <sup>1/</sup>	3.37	4.7.31	
Seal	3.9	4.7.3	

<sup>1/</sup> Additional sample units may be required for different terminal designs.

4.7 Methods of inspection.

NOTE: As used herein, "coil" on classes A and B relays may be used interchangeably for "input" on class C relays; and "contacts" on classes A and B relays may be used interchangeably for "output" on class C relays.

4.7.1 Visual and mechanical. Relays shall be inspected to verify that the design, physical dimensions, and weight, materials, interface and construction, marking, and workmanship are in accordance with the applicable requirements (see 3.1, 3.5, 3.6, 3.42, and 3.45, respectively). Visual and mechanical inspection shall be performed with professional quality measuring equipment to determine dimensions and weights.

## MIL-PRF-83726D

4.7.1.1 Internal visual and mechanical. Relays shall be examined to verify that the materials, internal design and construction, physical dimensions, and workmanship are in accordance with the applicable requirements (see [3.1](#), [3.5](#), [3.6](#), [3.43](#) and [3.45](#)). Verification of materials, design, and construction shall be certified as specified in [4.2.1](#).

4.7.1.2 External visual and mechanical. Relays shall be examined to verify that the materials, external design and construction, marking, workmanship, and header glass are in accordance with the applicable requirements (see [3.1](#), [3.5](#), [3.6](#), [3.42](#), [3.43](#), and [3.45](#)). Verification of materials, design, and construction shall be provided as specified in [4.2.1](#). Physical dimensions and weight shall be measured on two sample units only.

4.7.1.3 Inspection of product. Relays shall be examined to verify that the marking, workmanship, and header glass are in accordance with the applicable requirements (see [3.1](#), [3.42](#), [3.43](#), and [3.45](#)). Physical dimensions and weight shall be measured on two sample units only.

4.7.2 Screening (see [3.6](#)). Solid state relays (class C) shall be screened as specified below, in the order shown.

4.7.2.1 High temperature storage (stabilization bake). Relays shall be tested in accordance with method 1008 of [MIL-STD-883](#). Unless otherwise specified, test condition B and a time duration of 24 hours minimum shall apply.

4.7.2.2 Temperature cycling. Relays shall be tested in accordance with method 1010 of [MIL-STD-883](#), test condition B. The following details shall apply:

- a. Special mounting: Relays shall be suspended in the test chamber by twine, or other nonheat-conducting material. Test leads may be used for mounting; however, they shall not provide a heat sink.
- b. End-point measurements and inspections: None.

4.7.2.3 Interim (pre-burn-in) electrical parameters (when specified). Relays shall be tested as specified in device screening (see [A-A-55568](#)).

4.7.2.4 Burn-in test. Relays shall be tested in accordance with method 1015 of [MIL-STD-883](#). The following details and exceptions shall apply:

- a. Test duration of 160 hours minimum.
- b. Test condition B.
- c. Test temperature: +125°C ambient minimum.
- d. Test mounting: Normal mounting means.
- e. As specified in [4.7.2.3](#).
- f. Not applicable.
- g. Time measurements completed: As specified in [4.7.2.3](#).

## MIL-PRF-83726D

4.7.3 Seal (see 3.9). Relays shall be tested in accordance with 4.7.3.1, 4.7.3.2, or 4.7.3.3 as applicable. Attribute data is acceptable.

4.7.3.1 Environmentally-sealed (see 3.9.2). Relays shall be tested in accordance with method 112 of MIL-STD-202. The following details shall apply:

- a. Unless otherwise specified (see 3.1), test condition letter D.
- b. Measurement after test: None.

4.7.3.1.1 Environmentally-sealed and hermetically-sealed (potted) relays (alternate method (see 3.9.2)). Relays shall be tested as follows:

- a. Prior to installing a gasket on the relay header (if a gasket is used), the relay shall be totally immersed in a container of "tap" water. (The "tap" water as used here means ordinary drinking water that has not been altered in any way, such as by the addition of any other substance or distilling.) The part of the relay closest to the surface of the water shall be a minimum of 1 inch (25.4 mm) below this surface.
- b. The container and water-covered relay shall then be placed in a vacuum chamber. The chamber shall be sealed. The chamber pressure shall be reduced from room ambient to 1 inch (75,000 feet) +0.0 - 0.2 inch of mercury within 5 minutes, and shall be maintained at this level for 30 minutes minimum. The chamber pressure shall be increased to room ambient within 1 minute, and shall be maintained at room ambient pressure for 30 minutes, minimum. The foregoing shall constitute one cycle. The relay shall remain fully immersed in the water during the cycle.
- c. Within a maximum of one-half hour after the cycle, each relay shall be removed from the water and dried by shaking, wiping, or blowing with contaminant-free air or gas, but not by any form of heating or baking.
- d. Within a maximum of one-half hour after drying, each relay shall be subjected to the DWV and IR tests.

4.7.3.2 Relays sealed with a gas containing a tracer (See 3.9.1). Relays sealed with a gas containing a tracer shall be tested in accordance with method 112 of MIL-STD-202, or at the option of the manufacturer, method 1014 of MIL-STD-883. The following details shall apply:

- a. Method 112 of MIL-STD-202:
  - (1) Test condition C, procedure IV. Relays shall be back-filled with a gas containing a helium tracer (90 percent dry gas and 10 percent helium). Silicone oil shall not be used.
  - (2) Leakage rate sensitivity:  $1 \times 10^{-8}$  atm cm<sup>3</sup>/s.
  - (3) Measurements after test: Not applicable.
- b. Method 1014 of MIL-STD-883, test condition B.

4.7.3.3 Relays sealed with a gas not containing a tracer (See 3.9.1). Relays sealed with a gas not containing a tracer shall be tested in accordance with method 1014 of MIL-STD-883. At the option of the manufacturer, either 4.7.3.3a or 4.7.3.3b may be used. The following details shall apply:

## MIL-PRF-83726D

## a. Method 1014 of MIL-STD-883:

- (1) Test condition A<sub>1</sub> or A<sub>2</sub>.
- (2) Measurements after test: Perform a gross leak test in accordance with method 112 of MIL-STD-202, test condition A, B, or D. Silicone oil shall not be used. At the option of the manufacturer, the gross leak test of method 1014 of MIL-STD-883, test condition C may be used.

## b. Method 1014 of MIL-STD-883, test condition B.

4.7.4 DWV (see 3.10). Relays shall be tested as specified in 4.7.4.1 and, when applicable (see 3.1), in accordance with 4.7.4.2. These tests shall be performed with relays in energized and deenergized condition. NOTE: To avoid unnecessary failures, test voltages shall not be applied indiscriminately.

4.7.4.1 At atmospheric pressure. Relays shall be tested in accordance with method 301 of MIL-STD-202. The following details shall apply:

- a. Magnitude of test voltage and nature of potential: As specified in table VIII.
- b. Duration of application of test voltage: As specified in table VIII.
- c. Points of application of test voltage: Unless otherwise specified (see 3.1), between all mutually isolated terminals and between all terminals and the case.
- d. Attribute data is acceptable.

TABLE VIII. DWV test details.

Test voltage (V rms)						System voltage (see 6.7) 4/
At atmospheric pressure 1/				At reduced barometric pressure (1 minute) 2/		
Qualification inspection (1 minute) 2/		Conformance inspection 3/				
Class		Class		Class		
A and B	C	A and B	C	A and B	C	
1,000	1,000	1,250	1,000	500	500	28 V dc
1,250	1,000	1,500	1,000	500	500	115 V ac
1,500	1,000	1,800	1,000	700	500	115/200 V ac 5/

- 1/ When the DWV test is performed following the life test specified in 4.7.34, the test voltage may be reduced to 75 percent of the applicable value specified, but not less than 1,000 V.
- 2/ The test potential shall be applied or reduced at a maximum rate of change of 250 V per second.
- 3/ For performing conformance inspection, a 2 second to 5 second test at 120 percent of the 1-minute voltage may be used in lieu of the 1-minute test; however, the 1-minute test is mandatory if defects are discovered in production inspection.
- 4/ If coil and contact are rated for different voltages, each shall be tested to case in accordance with its respective system voltage; however, the test between coil and contact terminals shall be in accordance with the higher of the two system voltages.
- 5/ For relays rated above 200 V, the test potential for 1 minute shall be twice rated voltage plus 1,000 V, with a minimum of 1,500 V. The test potential for 2 seconds to 5 seconds shall be 20 percent higher than the 1-minute test voltage. The test voltage at maximum specified altitude shall be 50 percent of the 1-minute value with a minimum of 750 V, rms.

## MIL-PRF-83726D

4.7.4.2 Temperature-altitude dielectric. Relays shall be tested in accordance with methods 105 and 301 of [MIL-STD-202](#). This test applies only to relays for use above 50,000 feet altitude. The relay shall be brought to a stabilized condition at the high temperature, high altitude pressure specified (see [3.1](#)). When in the above condition, the tests of [4.7.4.1](#) shall be performed.

4.7.5 IR (see [3.11](#)). Relays shall be tested in accordance with method 302 of [MIL-STD-202](#) with the relay in the energized and deenergized condition. The following details shall apply:

- a. Test condition letter B.
- b. Points of measurement: As specified in [4.7.4.1c](#).
- c. Attribute data is acceptable.

4.7.6 Static contact resistance, contact voltage drop, and output voltage drop (see [3.12](#)). The static contact resistance or static contact voltage drop shall be required for each pair of contacts for class A and class B type relays. If both contact voltage drop and static contact resistance are specified in the documents the manufacturer has the choice of which to run for the contacts. However, each contact must be tested. Output voltage drop shall be performed on class C type relays.

4.7.6.1 Static contact resistance (see [3.12](#)). Relays shall be tested in accordance with method 307 of [MIL-STD-202](#). The following details and exceptions shall apply:

- a. Method of connection: The point of measurement shall be on leads external to the case. Suitable jigs and fixtures shall be used.
- b. Test load: Test current shall be 100 mA at a voltage equal to or below rated voltage, except those rated for low level. See [6.1.1](#) for low level voltage rating. For low level, the current shall be 10 mA maximum (dc or peak ac).
- c. Post test current: Load current and voltage shall be 100 mA maximum at a voltage equal to or below rated voltage, unless life tests are specified in the grouping. When life tests are specified in the grouping, the same current at a maximum of rated voltage as the life test, or 100 mA maximum at 28 V dc maximum, shall be used.
- d. Points of measurements:
  - (1) Between all normally closed mated contacts.
  - (2) Between all normally open mated contacts, with the coil energized with rated coil voltage (or current) for non-latch type relays, or in the latch/reset position for magnetic latch type relays, with or without coil energized.
- e. Number of activations prior to measurement: During static resistance tests, the number of activations prior to measurement is none.
- f. Number of test activations: Maximum of three activations in each closed contact position for qualification Q1. For all remaining groups in the qualification table, group A, group B, and group C, one to three activations in each closed contact position.

## MIL-PRF-83726D

- g. Number of measurements per activation: One in each closed contact position. The readings shall be taken after the circuit has stabilized and within a maximum time of 2 seconds after activation.

4.7.6.2 Contact voltage drop (see 3.12). Relays shall be tested in accordance with method 307 of MIL-STD-202. The following details and exceptions shall apply.

- a. Method of connection: The point of measurement shall be on leads external to the case. Suitable jigs and fixtures shall be used.
- b. Test load: Test current shall be rated resistive current at rated voltage or less. See 6.1.1 for low level voltage rating. If a lower test current is used, the millivolt drop shall be adjusted according to Ohm's law.
- c. Post test loads for intermediate current and life: When intermediate current is specified in the grouping, the same current as intermediate current, or 100 mA, at a voltage equal to or below rated voltage shall be used. When life tests are specified in the grouping, the same current as the high level life test, or 100 mA, at a voltage equal to or below rated voltage shall be used. If a lower test current is used, the millivolt drop shall be adjusted according to Ohm's law.
- d. Points of measurement:
  - (1) Between all normally closed mated contacts.
  - (2) Between all normally open mated contacts, with the coil energized with rated coil voltage (or current) for non-latch type relays, or in the latch/reset position for magnetic latch type relays, with or without coil energized.
- e. Number of activations prior to measurement: During contact voltage drop tests, the number of activations prior to measurements is none.
- f. Number of test activations: Maximum of three activations in each closed contact position for qualification Q1. For all remaining groups in the Qualification table, group A, group B, and group C, one to three activations in each closed contact position.
- g. Number of measurements per activation: One in each closed contact position. The readings shall be taken after the circuit has stabilized and within a maximum time of 2 seconds after activation.

4.7.6.3 Class C relays (output voltage drop).

- a. Method of connection: Connection jigs or other suitable means.
- b. Test load: Rated voltage and current.
- c. Number of actuations prior to measurement: None.
- d. Measurement: Measure voltage difference between input and output terminals.

4.7.7 Leakage current (class C relays) (see 3.13). With the relay connected to maximum system voltage and rated load, operate relay normally. During the load off interval, measure the leakage current to the load.

## MIL-PRF-83726D

4.7.8 Input current (3.14). The maximum operating voltage (see 3.1) shall be applied to the input and control terminals, and the input current and, if applicable, the control current shall be measured during the timing cycle and during steady-state.

4.7.9 Waveform distortion (class C, ac relays) (see 3.15).

- a. Apply the rated voltages (see 3.1) to the input and bias (when applicable). Apply rated output voltage and adjust the load to obtain rated current with relay turn on.
- b. Connect an oscilloscope across relay output and adjust the oscilloscope to display one complete cycle of relay output voltage.
- c. With relay turned on, observe output voltage on the oscilloscope for waveform distortion.

4.7.10 DC offset voltage (class C, ac relays) (see 3.16).

- a. Apply rated voltages and currents to the output and bias (when applicable).
- b. Apply minimum turn-on voltage to the input and measure the dc component of the output circuit voltage drop.

4.7.11 Current range (class C, ac relays) (see 3.17). Tests shall be conducted as described in 4.7.9 and 4.7.10 except the output current shall be 1 percent of highest load current rating.

4.7.12 Zero crossover (class C, ac relays) (when specified, see 3.1) (see 3.18 and 6.9). Apply rated output voltage and resistive load to the relay. Apply rated input voltage. Apply and remove the input control voltage at random and monitor the output for zero voltage turn-on and zero current turn-off.

4.7.13 Bias current (class C relays) (when applicable) (see 3.19).

- a. Apply rated voltages and currents to the output and bias (see 3.1).
- b. Read the bias current when the relay is energized with the rated input voltage (relay shall be in on-state).

4.7.14 Maximum deactuation voltage (class C relays) (see 3.20). Apply minimum specified input voltage to turn the relay on, then reduce this input to the maximum deactuation voltage specified until the relay turns off and observe that the relay has deactuated.

4.7.15 Transients (see 3.21).

4.7.15.1 Voltage (surge) (see 3.21.1). Unless otherwise specified (see 3.1), relays shall be subjected, at the input or control terminals, to the maximum transient voltage limits for the time specified by MIL-STD-704. No impedance other than that of the wire or cable shall be used between the power source and the input or control terminals for this test.

4.7.15.2 Susceptibility (spike) (see 3.21.2). Relays shall be subjected, at the input or control terminals, to a transient spike voltage of  $\pm 600$  V, 100 kHz, duration in accordance with MIL-STD-704 for 10 applications spaced 10 seconds apart. Relays shall be tested before, during, and after exposure for timing cycle and after exposure for recycle tests as specified in 4.7.16.1.1 and 4.7.17, respectively.

## MIL-PRF-83726D

4.7.15.2.1 Alternate transient susceptibility test. Charge a one microfarad capacitor to 600 V. With a 60 ohm resistor in series, discharge capacitor across the input and output control terminals. Five applications spaced 10 seconds between applications. Reverse polarity and repeat five additional applications. Relays shall be tested before, during and after exposure for timing cycle and after exposure for recycle tests as specified in 4.7.16.1.1 and 4.7.17, respectively.

4.7.15.3 Susceptibility, extraneous voltage (applicable to type IIA) (see 3.21.3). With the relay operating voltage applied, apply 25 percent of the nominal control voltage and monitor the output to see that there is no change in condition. Conduct the test at minimum, normal room ambient, and maximum temperature specified.

4.7.15.4 Self-generated (spike) (see 3.21.4). The relay shall be operated normally at nominal voltage. At the input and control terminals, check for transients when relay is switched on or off and during time interval. (This test to be made without loads on the output controls.)

4.7.16 Timing cycle (see 3.22). For group A and group B, all relays shall be subjected to, and meet the requirements of 4.7.16.1. For group A and group B, rated voltage is the nominal operating coil voltage (see 3.1). For group C, and qualification, the tests below shall be performed applying first the maximum specified and then the minimum specified rated voltages (see 3.1). For Type IIA relays, the testing shall include the application of the maximum and minimum voltages in a manner such that, one test shall have both input and control at maximum, then both input and control at minimum, then the input at maximum and the control at minimum, and then the input at minimum and the control at maximum. For group C, and qualification, the tests of 4.7.16.2 and 4.7.16.3 only shall be performed.

CAUTION: If a rise or fall time of the power source is greater than 10  $\mu$ s, the timing cycle may be adversely affected.

4.7.16.1 At room ambient conditions. Relays shall be tested in accordance with the following, as applicable. For clarification, energized means the normally closed contacts are open and the normally open contacts are closed and deenergized means the normally open contacts are open, and the normally closed contacts are closed.

- a. Type I: When rated voltage is applied to the input terminals, the relay is energized or the output turned on for class C types, within the delay time interval specified (see 3.1). When rated operating voltage is removed, the relay shall return to the deenergized condition or the output turned off for class C types, within the specified release time (see 3.1).
- b. Type IIA: When rated voltages are applied to the input and control terminals, the relay is energized or for class C types the output switch turned on, within the specified operate time (see 3.1). When the voltage is removed from the control terminal, the relay shall return to the deenergized condition or for class C type the output switch turned off, within the delay time interval specified (see 3.1).
- c. Type IIB: Test as above for type I (except the operate delay is not applicable and allowance must be made for the specified release delay prior to reapplication of the rated operating voltages).
- d. Types IV and V: When rated voltage is applied to the input terminals, the relay is energized within the voltage range and operate time interval specified, as applicable, (see 3.1). When rated voltage is removed, or reduced to the voltage range specified (see 3.1), the relay shall return to the deenergized condition within the voltage range and delay time interval specified (see 3.1).



## MIL-PRF-83726D

4.7.16.1.1 At nominal input voltage. Relays shall be tested in accordance with 4.7.16.1 except at nominal input voltage.

4.7.16.2 High temperature. The relay shall be energized at the maximum rated voltage, as applicable, and at maximum rated temperature (see 3.1) for a period of 4 hours. At the end of this period starting within 1 minute after removal of power, the relay, while still at the maximum temperature, shall be tested as specified in 4.7.16.1. The minimum voltage shall be that specified for the high temperature test. The relay contacts or output circuit shall not be loaded during this test. For monitoring purposes, the relay contacts or output circuit shall not be loaded in excess of 100 mA at 6 V dc or peak ac. The measured values of time and voltage, as applicable, shall be within the tolerances specified (see 3.1).

4.7.16.3 Low temperature. The relay shall be subjected, unenergized, to the minimum rated temperature (see 3.1) for a period of 4 hours. At the end of this period the relay, while still at the minimum temperature, shall be tested as specified in 4.7.16.1. The relay contacts or output circuit shall not be loaded during this test. For monitoring purposes the relay contacts or output circuit shall not be loaded in excess of 100 mA at 6 V dc or peak ac. The measured values of time and voltage, as applicable, shall be within the tolerances specified (see 3.1).

4.7.17 Recycle time (see 3.23). For group A and group B, all relays shall be subjected to, and meet the requirements of 4.7.17.1. For group A and group B, rated voltage is the nominal operating coil voltage (see 3.1). For group C and qualification, the tests below shall be performed applying first the maximum specified and then the minimum specified rated voltages (see 3.1). For type IIA relays, testing shall include the application of the maximum and minimum voltages in a manner such that, one test shall have both input and control at maximum, then both input and control at minimum, then the input at maximum and the control at minimum, and then the input at minimum and the control at maximum. For group C and qualification, the tests of 4.7.17.2 and 4.7.17.3 shall be performed.

4.7.17.1 At room ambient temperature. Relays, except type IV and type V, shall be tested in accordance with 4.7.16.1 as applicable, except the voltage to the input or control terminals, as applicable, shall be removed and reapplied, or reapplied and removed, as applicable, for the not greater than recycle time specified (see 3.1). The relay shall repeat normal operation and the timing cycle shall be within the tolerance specified (see 3.1). The test shall be performed both during a timing interval and following a timing interval.

4.7.17.2 At high temperature. Relays, except type IV and type V, shall be tested in accordance with 4.7.17.1, except that the ambient temperature and conditions of 4.7.16.2 shall apply as applicable.

4.7.17.3 At low temperature. Relays, except type IV and type V, shall be tested in accordance with 4.7.17.1, except that the ambient temperature and conditions of 4.7.16.3 shall apply as applicable.

4.7.18 Reverse polarity (dc operated relays) (see 3.24). Reverse polarity of maximum rated voltage shall be applied to the input and control terminals for a period of not less than 1 minute. Following the test, the relay shall be tested for the timing cycle and recycle time as specified in 4.7.16.1.1 and 4.7.17, respectively.

4.7.19 Electromagnetic interference (see 3.25). Relays shall be subjected to the electromagnetic interference tests specified in MIL-STD-461, class 1D and MIL-STD-461 with contacts unloaded.

4.7.20 Crosstalk (when specified, see 3.1) (see 3.26). Crosstalk shall be measured using equipment which shall have an input impedance of 1 M $\Omega$ , minimum, and shall be paralleled with a capacitance of 20 picofarads maximum. A 1.0 to 10.0 V peak-to-peak input signal frequency up to 10 MHz shall be applied to the switching circuit through coaxial cable, terminated in 50 ohms  $\pm$ 5 percent at the device terminal.

## MIL-PRF-83726D

The input signal amplitude shall be measured at the terminals of the relay. The terminals where crosstalk is to be detected, shall be connected through a similar type coaxial cable, terminated in 50 ohms  $\pm$ 5 percent at the measuring device. The resultant attenuation, in decibels (dB) equals:

$$20 \left( \log_{10} \frac{V_{in}}{V_{out}} \right)$$

4.7.21 Capacitance (when specified, see 3.1) (see 3.27). Relays shall be tested as specified in method 305 of MIL-STD-202. The following detail and exception shall apply:

- a. Test frequency: 1 kHz, unless otherwise specified (see 3.1).
- b. Points of measurement as specified (see 3.1).

4.7.22 Continuous current (see 3.28). Relays shall be energized continuously for 100 hours with maximum rated voltage applied to the input or control terminals and with maximum rated dc load connected to each output circuit. The test shall be performed at the maximum temperature and altitude specified (see 3.1). Following the test and with the relay at the maximum temperature and altitude, and contacts still loaded, the relays shall be deenergized and shall immediately be tested for timing cycle, and recycle time as specified in 4.7.16.2 and 4.7.17, respectively. The minimum voltage shall be a specified for the continuous current test (see 3.1). After the test, the relay shall be tested for DWV, IR, contact voltage drop (or resistance) as specified in 4.7.4.1, 4.7.5, and 4.7.6, respectively.

4.7.23 Resistance to soldering heat (not applicable to plug-in relays) (see 3.29). Relays shall be tested in accordance with method 210 of MIL-STD-202. The following details shall apply:

- a. Depth of immersion in molten solder: Within .060  $\pm$ .020 inch (1.52  $\pm$ 0.51 mm) of the relay base.
- b. Test condition letter B.
- c. Measurements after test: DWV, IR, timing cycle, and recycle time shall be measured as specified in 4.7.4.1, 4.7.5, 4.7.16.1.1, and 4.7.17, respectively.

4.7.24 Salt spray (corrosion) (see 3.30). Relays shall be tested in accordance with method 101 of MIL-STD-202. The following details and exceptions shall apply:

- a. Applicable salt solution: 5 percent.
- b. Test condition letter B.
- c. Inspection after test: Relays shall be inspected for evidence of peeling, chipping, blistering of the finish, or exposure of base metal due to corrosion.
- d. Measurement after test: Timing cycle and recycle time shall be measured as specified in 4.7.16.1.1 and 4.7.17.1.

4.7.25 Thermal shock (see 3.31). Relays shall be tested in accordance with method 107 of MIL-STD-202. The following details shall apply:

- a. Test condition letter: As specified (see 3.1).

## MIL-PRF-83726D

- b. Measurements after cycling: Relays shall be visually examined for cracking, peeling, and flaking of the finish, and the DWV, IR, contact voltage drop (or resistance), timing cycle, and recycle time shall be measured as specified in [4.7.4.1](#), [4.7.5](#), [4.7.6](#), [4.7.16.1.1](#), and [4.7.17.1](#), respectively.

4.7.26 Low temperature operation (see [3.32](#)). The relay shall be subjected to the low temperature specified (see [3.1](#)) for a period of 48 hours. At the end of this period, and with the relay at the low temperature, the timing cycle, recycle time, and contact voltage drop (or resistance) shall be measured as specified in [4.7.16](#), [4.7.17.1](#), and [4.7.6](#), respectively. (These tests shall be accomplished in the sequence listed and in a minimum amount of time to prevent significant heating of the coil, where applicable.) The relay shall then be tested intermittently for timing cycle and recycle time until it attains room temperature. Relays which contain permanent magnets in the magnetic circuit, shall, in addition to the above tests, be subjected to the demagnetizing effect of the cold coil energized with maximum voltage specified. During the low temperature test, after approximately 24 hours, these relays shall be operated by the sudden application of maximum coil voltage for one operation. All units subjected to this demagnetizing effect shall be tested in accordance with high temperature timing cycle (see [4.7.16.2](#)), at the conclusion of this test.

4.7.27 Shock (specified pulse) (see [3.33](#)). Unless otherwise specified (see [3.1](#)), relays shall be tested in accordance with method 213 of [MIL-STD-202](#). The following details and exceptions shall apply:

- a. Mounting method: For relays having flanges or studs, mounting shall be by the flanges or studs, and for relays without flanges, mounting shall be by plugging into sockets, or other suitable means approved by the qualifying activity.
- b. Test condition letter: As specified (see [3.1](#)).
- c. Electrical-load conditions: In each direction of shock, the relay shall be deenergized during two shocks and energized with rated control voltage or current during one shock.
- d. Measurements during shock: Contacts shall be monitored with an adequate test circuit as approved by the qualifying activity. The test circuit shall be capable of verifying that no opening of closed contacts in excess of 10  $\mu$ s and no closure of open contacts in excess of 1  $\mu$ s. The contact load shall be 10 mA maximum at 6 V dc maximum (open contacts shall be wired in parallel; closed contacts shall be wired in parallel and connected in series). Attribute data is acceptable.
- e. Inspection after shock: Relays shall then be inspected for evidence of loosening of parts.
- f. Measurements after test: Timing cycle and recycle time shall be as specified in [4.7.16.1.1](#) and [4.7.17.1](#), respectively.

4.7.28 Vibration, high frequency (see [3.34](#)).

4.7.28.1 Vibration, high frequency (class A and class B). Unless otherwise specified (see [3.1](#)), relays shall be tested in accordance with method 204 of [MIL-STD-202](#). The following details and exceptions shall apply:

- a. Mounting method: For relays having flanges or studs, mounting shall be by the flanges or studs, and for relays without flanges, mounting shall be by plugging into sockets, or other suitable means approved by the qualifying activity.
- b. Electrical load conditions: Relays shall be tested with the coil energized for 2 hours at rated

## MIL-PRF-83726D

voltage and with the coil deenergized for 2 hours, in each of the three mutually perpendicular directions (relays with intermittent duty coils shall not be energized above their duty cycle). Contacts shall not be loaded as specified in [4.7.28.1d](#).

- c. Test condition letter F.
- d. Tests during vibration: As specified in [4.7.27d](#). Attribute data is acceptable.
- e. Measurements and inspections after vibration: DWV, insulation resistance, contact voltage drop (or resistance), timing cycle, and recycle time as specified in [4.7.4.1](#), [4.7.5](#), [4.7.6](#), [4.7.16.1.1](#), and [4.7.17.1](#), respectively. Relays shall then be inspected for loosening of parts.

**4.7.28.2 Vibration, high frequency (class C).** Unless otherwise specified (see [3.1](#)), relays shall be tested in accordance with method 204 of [MIL-STD-202](#). The following details and exceptions shall apply:

- a. Mounting method: As specified in [4.7.28.1a](#).
- b. Electrical-load conditions: Relays shall be tested, energized for 2 hours at rated voltage and deenergized for 2 hours, in each of the three mutually perpendicular directions.
- c. Test condition letter F.
- d. Measurements and inspection after vibration: As specified in [4.7.28.1e](#), except substitute output voltage drop in accordance with [4.7.6.3](#) for contact voltage drop (or resistance) in accordance with [4.7.6](#).

**4.7.28.3 Vibration random.** When specified (see [3.1](#)), relays shall be tested in accordance with method 214 of [MIL-STD-202](#). The following details shall apply:

- a. Mounting method: As specified in [4.7.28.1a](#).
- b. Electrical-load conditions: Relays shall be tested with the coil energized for 7.5 minutes at rated voltage and with the coil deenergized for 7.5 minutes, in each of the three mutually perpendicular directions (relays with intermittent duty coils shall not be energized above their duty cycle). Contacts shall be loaded as specified in [4.7.27d](#).
- c. Test condition I, letter G, duration 15 minutes.
- d. Tests during vibration: As specified in [4.7.27d](#).
- e. Measurements and inspection after vibration: As specified in [4.7.28.1e](#).

**4.7.29 Acceleration (class A and class B relays)** (see [3.35](#)). Relays shall be tested in accordance with method 212 of [MIL-STD-202](#). The following details and exceptions shall apply:

- a. Mounting method: As specified in [4.7.27a](#), in each of three mutually perpendicular positions.
- b. Test condition letter A, except that acceleration shall be applied in each direction along three mutually perpendicular axes of the specimen and one of the axes shall be in the direction most

## MIL-PRF-83726D

likely to cause malfunction. Unless otherwise specified (see 3.1), the acceleration force shall be 15g's.

- c. Electrical operating conditions during acceleration: Relays shall be tested with the relay in deenergized condition and repeated with the relay coil energized at specified 23°C pickup voltage. An indicating instrument shall be connected across the contacts while the relay is undergoing this test to determine the ability of the contacts to remain in the proper position. Open contacts shall be wired in parallel and closed contacts shall be wired in series during this test.
- d. Measurements during acceleration: Timing cycle and recycle time as specified in 4.7.16.1.1 and 4.7.17.1, respectively.

4.7.30 Resistance to solvents (see 3.36). Relays shall be tested in accordance with method 215 of MIL-STD-202. The following details and exceptions shall apply:

- a. Portion of the specimen to be brushed: All marking.
- b. Specimens to be tested: One sample shall be tested with each solvent solution. For qualification inspection, samples in excess of the available number of solvents shall be exempt from test.
- c. Examination: Specimens shall be inspected for legibility of marking.

4.7.31 Strength of terminals and mounting studs (see 3.37).

4.7.31.1 Strength of threaded terminals and mounting studs. Relays having mounting studs or threaded terminals, shall be tested to determine compliance with the strength requirements specified in 3.37.1, table I, and table II. The specified pull force shall be applied both coaxially with the threaded terminal in a direction away from the main body of the relay, and again normal to the threaded axis of the terminal in approximately the same plane as the seat for the terminal lug. The specified torque shall be applied to the terminal mounting nut, or screw with all terminal mounting hardware, including one terminal lug of proper size, assembled in proper order. The relays shall withstand the specified force for 1 minute without damage. Relays, with threaded terminal assemblies soldered in place, shall be tested as follows (not applicable to relays with maximum temperature rating above +125°C). The relays shall be stabilized in a 180°C ambient temperature. After stabilizing at this temperature for a minimum of 2 hours, the terminals shall be subjected to the pull and torque test as specified above.

4.7.31.2 Strength of solder-lug, plug-in, printed wiring, and wire-lead terminals (see 3.37.2). Relays shall be tested in accordance with method 211 of MIL-STD-202 in accordance with the following, as applicable. Unless otherwise specified herein, two terminals of each discrete design, size, and configuration shall be tested; however, if there is only one of such design, size and configuration, it shall be tested.

4.7.31.2.1 Pull test (all terminal types). Terminals shall be tested as specified in test condition letter A; the force shall be as specified (see 3.1).

4.7.31.2.2 Bend test (not applicable to plug-in terminals). Terminals shall be tested as specified in test condition letter B (two bends) or C, as applicable. Loads for test condition letter C shall be as specified (see 3.1).

4.7.31.2.3 Twist test (wire lead terminals only). All terminals shall be tested as specified in test condition letter D, except during application of torsion, each terminal shall be rotated 45 degrees in one

## MIL-PRF-83726D

direction, then returned to start; rotated in opposite direction 45 degrees, then returned to start. Each terminal shall be subjected to two such rotations and returns. Each terminal shall be held at a point .75 inch (19.05 mm) from the point of emergence from the relay and in one plane shall be bent 20 degrees  $\pm 5$  degrees in one direction, then returned to start; bent in opposite direction 20 degrees  $\pm 5$  degrees, then returned to start. This procedure shall then be repeated in the perpendicular plane.

Following these tests, relays shall be inspected for evidence of loosening or breaking of the terminals and other damage that could adversely affect the normal operation of the relay, the requirements of 3.45 are not applicable.

4.7.32 Solderability (see 3.8). Solder terminations shall be tested in accordance with method 208 of MIL-STD-202. All terminations shall be tested. Attribute data is acceptable.

4.7.33. Overload (class C only) (see 3.38). The contacts of the relay shall be caused to make and break the overload values and durations as shown in table IX for 50 operations at each of the maximum system voltage (open circuit) ratings. An individual relay shall be used for each load condition specified. For double throw relays, separate tests shall be performed for the normally open and for the normally closed contacts. Each relay case shall be connected to system ground through a single normal-blow fuse rated at the greater of 100 mA or 5 percent of load current. The equipment shall be capable of monitoring 40 percent minimum of the actual opened and closed time of each contact. The monitoring equipment shall automatically hold the relay under test in the state in which the failure occurs (energized or de-energized) and the contact voltage shall be removed unless otherwise specified. All contacts in each sample unit shall switch identical loads unless otherwise specified. Following cycling, the electrical continuity of each case-grounding fuse shall be checked. When 115/200 V ac three phase on relays with three or more poles, only three adjacent poles need to be tested.

TABLE IX. Overload values and durations.

Relay rating	Percent rated resistive load			Duty cycle (seconds)	
	28 V dc	115 V ac	115/200 V ac three phase	ON $\pm 0.05$	OFF $\pm 1$
0-24	400	400	600	0.2	20
25 and up	800	800	800	0.2	20

4.7.34 Loads and endurance (life) (see 3.38, 3.39, and 3.40). Test loads and circuits shall be so arranged that the specific current will flow through each pole. During all load or endurance (life tests, the relay enclosure shall be maintained at the electrical system ground to neutral through a F02 or F03 fuse in accordance with MIL-PRF-15160/2 or MIL-PRF-15160/3, rated at 5 percent of the rated resistive load but in no event greater than 3 A or less than 100 mA. Line-to-line and line-to-ground voltages shall be as specified (see 3.1). The load test cycles shall be performed in any number of continuous periods, each not less than 3 hours. Double-throw relays shall have the normally open (NO) and normally closed (NC) contacts tested. If the NO contacts and NC contacts are tested separately, an additional sample unit shall be provided for this test which shall be required to meet all other tests in the test sequence. If both NO and NC contacts of double-throw relays are being tested at the same time, a separate load shall be provided for each NO and NC contact. The movable contacts shall be connected to the power source, except for double break contacts. All loads shall be connected between the contacts and power supply ground or neutral. When testing multipole relays with three-phase ratings, three-phase loads shall be connected to adjacent contacts. During endurance tests, every operation of each contact shall be monitored for failure to make, carry, and break specified load. The minimum sensing period shall be 10 percent of the dwell time in the open or closed position. Test equipment must either lock in the state of

## MIL-PRF-83726D

failure or record the sequence number of the miss.

After the tests, DWV, IR, contact voltage drop (or resistance), timing cycle, and recycle time shall be measured as specified in 4.7.4.1, 4.7.5, 4.7.6, 4.7.16.1.1, and 4.7.17.1, respectively.

4.7.34.1 Loads and endurance (life) (class A, class B, and class C relays). Unless specified (see 3.1), relays shall be tested for 100,000 cycles or 500 hours, whichever occurs first, in accordance with 4.7.34.1.1 through 4.7.34.1.5 as specified (see 3.1). The input voltage (current) and output load shall be as specified (see 3.1). Unless otherwise specified (see 3.1), the ambient temperature of the test chamber shall be the maximum rated temperature (see 3.1). For each test, the output voltage drop shall be monitored during 40 percent minimum of each "ON" and "OFF" period. The duration of ON-time shall be 50 ±10 percent of each relay cycle.

4.7.34.1.1 Resistive. Suitable resistors shall be used.

4.7.34.1.2 Inductive. Current shall be rated current. Appropriate inductive load components (see 4.7.34.1.2 and 4.7.34.1.3, as applicable) shall be used. A suitable resistor may be placed in the circuit to obtain rated steady-state current flow.

4.7.34.1.2.1 Inductive load, dc. Unless otherwise specified (see 3.1), dc inductive loads shall be computed in accordance with the following procedures:

- a. The inductor shall be mounted in its normal operating position on a nonmagnetic plate with no immediately adjacent metal.
- b. The load circuit shall be energized through a bounce free contact from a power supply regulated to within 5 percent of the specific rated voltage as shown on figure 3.
- c. By measuring the time for the current to reach 63 percent of the final value, the dc inductance is calculated as:

$L = Rt$  where:

L is the inductance in henries.

R is the coil resistance in ohms.

T is the time in seconds for current to reach 63 percent of its final value.

4.7.34.1.2.2 Inductive load, ac. The load shall consist of inductive and resistive elements with 0.7 ± 0.05 lagging power factor at the voltage and frequency specified (see 3.1).

4.7.34.1.3 Lamp. The load shall consist of tungsten lamps which shall be operated at their rated voltage. The specified current (see 3.1) shall flow when the lamps have stabilized.

4.7.34.1.4 Motor load, dc (when specified). The relay shall be subjected to the minimum operating cycles for making six times the rated motor load of rated system voltage and breaking the normal rated motor load.

4.7.34.1.5 Motor load, ac (when specified). The ac motor load test shall be as specified in 4.7.34.1.4 except that the value of the ac inrush current shall be five times rated motor load current, or as specified (see 3.1).

MIL-PRF-83726D

4.7.34.2 Low level (when specified, see 3.1) (see 3.40). Relays shall be tested in accordance with method 311 of [MIL-STD-202](#). The following details shall apply:

- a. Number of misses considered a failure: One.
- b. Maximum dynamic contact resistance allowed: 100 ohms.
- c. Number of cycles of operation and cycling rate: 100,000 cycles.

4.7.35 Vibration scan (see 3.41). Relays shall be subjected to the vibration test method 204, test condition A, of [MIL-STD-202](#); however, only one cycle shall be performed. Sweeptime shall be reduced to the time required to sweep the entire range of frequencies specified (see 3.1). The relay shall be vibrated in each of the three mutually perpendicular axes. Relays having both normally open and normally closed contacts shall be subjected to one vibration scan in the deenergized condition and one scan in the energized condition. Contact monitoring shall be in accordance with [4.7.27d](#).

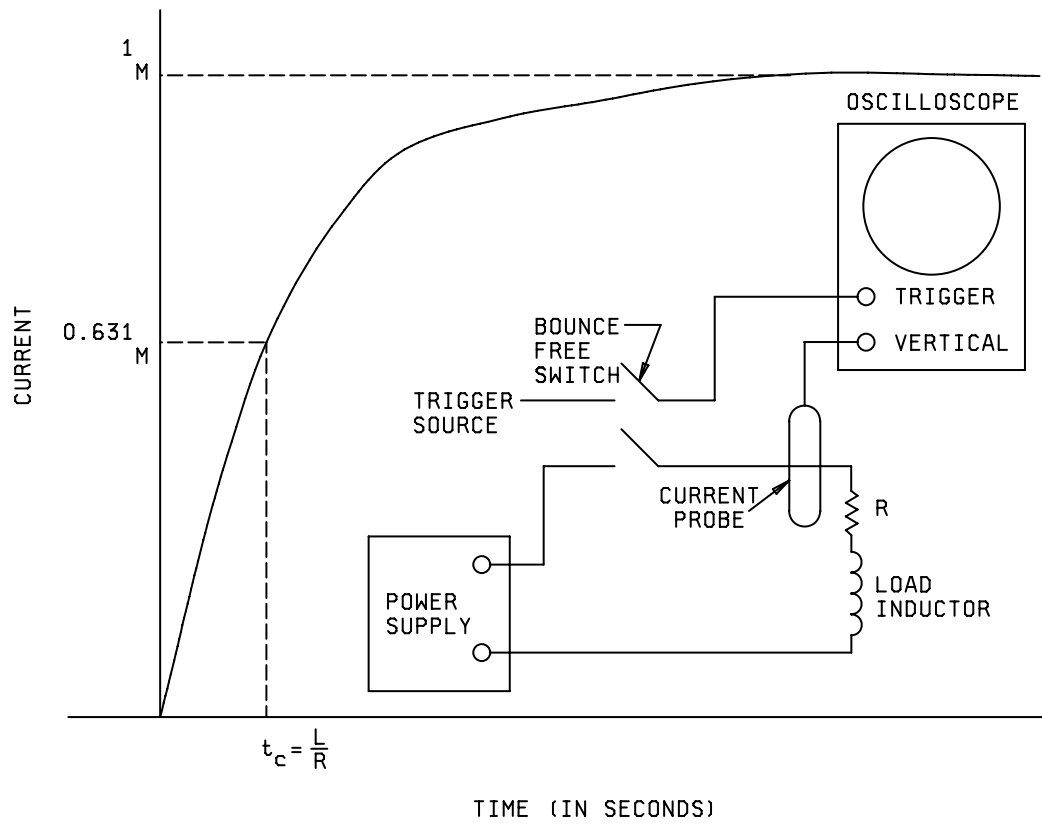

MIL-PRF-83726D

FIGURE 3. DC inductive load (inductive current rise time curve).

## MIL-PRF-83726D

## 5. PACKAGING

5.1 Packaging. For acquisition purposes, the packaging requirements shall be as specified in the contract or order (see 6.2). When packaging of materiel is to be performed by DoD or in-house contractor personnel, these personnel need to contact the responsible packaging activity to ascertain packaging requirements. Packaging requirements are maintained by the Inventory Control Point's packaging activities within the Military Service or Defense Agency, or within the military service's system commands. Packaging data retrieval is available from the managing Military Department's or Defense Agency's automated packaging files, CD-ROM products, or by contacting the responsible packaging activity.

## 6. NOTES

(This section contains information of a general or explanatory nature that may be helpful, but is not mandatory.)

6.1 Intended use. Relays conforming to this specification are intended for use in dc or ac (single or polyphase) electrical systems as a means of timing and controlling the making and breaking of circuits for electrically operated equipment and devices. Their principal areas of application, such as aircraft, missiles, spacecraft, and ground support equipment, does not preclude the use of these relays in other military applications. Time delay relays covered by this specification are intended to be able to operate satisfactorily in military systems under the following demanding conditions: Operating temperature range of  $-70^{\circ}\text{C}$  to  $+125^{\circ}\text{C}$ ; 1,100 g's of shock; and reduced susceptibility to corrosion in salt water environments. These requirements are verified under a qualification system. Thermal time delay relays are excluded from this specification. The following caution statements apply:

- a. The use of any coil voltage less than the rated voltage will compromise the operation of the relay.
- b. Transfer relay contacts shall not be used to ground load in one position and to 115 V terminal in another position. Transfer relay contacts shall not be used to transfer load between phases, nor between unsynchronized ac sources.
- c. Pick-up, hold, and dropout voltages are for test purposes only and are not to be used as design criteria.

6.1.1 Contact rating. The contact ratings of relays covered by this specification are based on load endurance tests which establish the relay capability to switch rated loads. For the purposes of this specification, contact load ratings are defined as follows:

- a. Low level: 10  $\mu\text{A}$  at 50 mV to 10 mA at 6 V.
- b. Intermediate: 10 mA at 6 V to 100 mA at 28 V.
- c. High level: Above 100 mA at 28 V.

6.2 Acquisition requirements. Acquisition documents must specify the following:

- a. Title, number, and date of the specification, the applicable specification sheet and the complete PIN (see 1.2.2).
- b. Levels of preservation and packing required (see 5.1).
- c. Special or additional identification marking requirements (see 3.42).

## MIL-PRF-83726D

- d. If the terminals are to be solder dipped (retinned).

6.3 Qualification. With respect to products requiring qualification, awards will be made only for products which are, at the time of award of contract, qualified for inclusion in the Qualified Products List whether or not such products have actually been so listed by that date. The attention of the contractors is called to these requirements, and manufacturers are urged to arrange to have the products that they propose to offer to the Federal Government tested for qualification in order that they may be eligible to be awarded contracts or orders for the products covered by this specification. Information pertaining to qualification of products may be obtained from (insert name, mailing address, and email of qualifying activity). An online listing of products qualified to this specification may be found at <http://assist.daps.dla.mil>.

6.4 Tin whisker growth. The use of alloys with tin content greater than 97 percent, by mass, may exhibit tin whisker growth problems after manufacture. Tin whiskers may occur anytime from a day to years after manufacture and can develop under typical operating conditions, on products that use such materials. Conformal coatings applied over top of a whisker-prone surface will not prevent the formation of tin whiskers. Alloys of 3 percent lead, by mass, have shown to inhibit the growth of tin whiskers. For additional information on this matter, refer to [ASTM-B545](#) (Standard Specification for Electrodeposited Coatings of Tin).

6.5 Shelf-life. This specification covers items where shelf life is a consideration. Specific shelf-life requirements should be specified in the contract or purchase order. The shelf-life codes are contained in the Federal Logistics Information System Total Item Record. Additive information for shelf-life management may be obtain from *DoD 4140.27-M Shelf-life Management Manual*, or the designated shelf-life Points of Contact (POC). The POC should be contacted in the following order: (1) the Inventory Control Points and (2) the DoD Service and Agency administrators for the DoD Shelf-Life Program. Appropriate POCs for the DoD Shelf-Life Program can be contacted through the DoD Shelf-Life Management website: <https://www.shelflife.hq.dla.mil/>.

6.6 Intermetallic contact. The finishing of metallic areas to be placed in intimate contact by assembly presents a special problem, since intermetallic contact of dissimilar metals results in electrolytic couples which promote corrosion through galvanic action. To provide the required corrosion protection, intermetallic couples are restricted to those permitted by [MIL-STD-889](#).

6.7 Fixturing losses. It is known that there is inherent resistance in sockets and wiring.. The qualifying activity will evaluate the manufacturer's system to determine conformance to specification requirements.

6.8 PIN. This specification requires a PIN that describes codification or classification and appropriate references to associated documents (see [1.2.2](#) and [3.1](#)).

6.9 Magnet wire (see [3.5.2](#)). It is recommended MW-1000 be considered for magnet wire.

6.10 Glossary. The definitions listed below are not a complete glossary of relay terminology, but rather are definitions of the technical terms as applied within the specification.

- a. Adjunct sealant: Any hydrocarbon or silicon material used on the exterior of the unit to improve seal of a hermetically sealed relay.
- b. Coil: One or more windings on a common form.
- c. Contacts: The current-carrying parts of a relay that open or close electrical circuits.

## MIL-PRF-83726D

- d. Contact arrangement: The combination of contact forms that make up the entire relay switching structure.
- e. Contact bounce: Intermittent opening of contacts after initial closure due to contact impact.
- f. Control voltage: The voltage applied to the input terminals to control the relay.
- g. Cycle, relay: A relay cycle is defined as a relay pickup and dropout, (one opening and one closure of a set of contacts). Therefore, a cycle consists of two operations.
- h. Hermetically sealed relay: A relay contained within an enclosure that is sealed by fusion to insure a low rate of gas leakage. This usually refers to metal-to-metal, or metal-to-glass sealing.
- i. Miss: Failure to establish the intended circuit conditions (high or low output resistance, as applicable).
- j. Operate time: The time between application of input or control voltage and the energization of the output contacts.
- k. Recycle time.
  - (1) Time delay on operate and interval timer relays: The minimum time that power must be removed from the input terminals in order to insure that a new timing cycle can be initiated within the specified timing tolerance.
  - (2) Time delay on release relays: The minimum time that power must be applied to the input or control terminals in order to insure that the timing cycle can be completed as specified.
- l. Relay: An electrically controlled device that opens and closes electrical contacts to effect the operation of other devices in the same or another electrical circuit.
- m. Release time: The time between removal of input or control voltage and the deenergization of the output contacts.
- n. Shelf life: A period of time a relay can be stored unused before detrimental changes occur which would cause the item not to properly perform its function within the requirements of this specification.
- o. Silicone: Any of a group of semi-inorganic polymers based on the structural unit  $R_2 SiO$ , where R is an organic group, characterized by wide range thermal stability, high lubricity, extreme water repellence, and physicochemical inertness, used in adhesives, lubricants, protective coatings, paints, electrical insulation, synthetic rubber, and prosthetic replacements for bodily parts.
- p. System voltage: The normal voltage of the electric system in which the relay will be required to operate.
- q. Time delay relay: A relay in which an additional time function is added beyond that normally inherent in the switching mechanism.

## MIL-PRF-83726D

- r. Types. Relay types are defined as follows (see [figure 4](#)):
- (1) Type I (time delay on operate). A time delay relay in which the switching or load circuits are operated for specified period of time after the input control circuits are energized.
  - (2) Types IIA and type IIB (time delay on release). A time delay relay in which the switching or load circuits are operated when the input control circuits are energized and remain operated for a specified period of time after the control circuit is deenergized.
  - (3) Type III (interval timer). A time delay relay in which the switching or load circuits are immediately energized and remain energized for a specified period of time after the input circuit is energized.
  - (4) Type IV (repeat cycle timer). A relay that repeats ON-OFF cycle as specified as long as the input circuit is energized, such as flashers.
  - (5) Type V (time sequence as specified, see [3.1](#)). Variations and combinations not included above have time characteristics specified in the specification sheet.
  - (6) Classes. Relay classes are defined as follows:
    - a. Class A and class B (hybrid). A combination of solid state circuit input elements function with an electromagnetic relay that performs the switching function or time delay.
    - b. Class C (solid state). A combination of electronic devices such as semiconductors, resistors, and capacitors, assembled to perform a time delay or switching function with no moving parts.
- s. Zero voltage turn on and zero current turn off - A characteristic that requires the relay to turn ON and turn OFF only at the half-cycle, zero crossing point when connected to a load, regardless of when the control voltage is applied or removed.

MIL-PRF-83726D

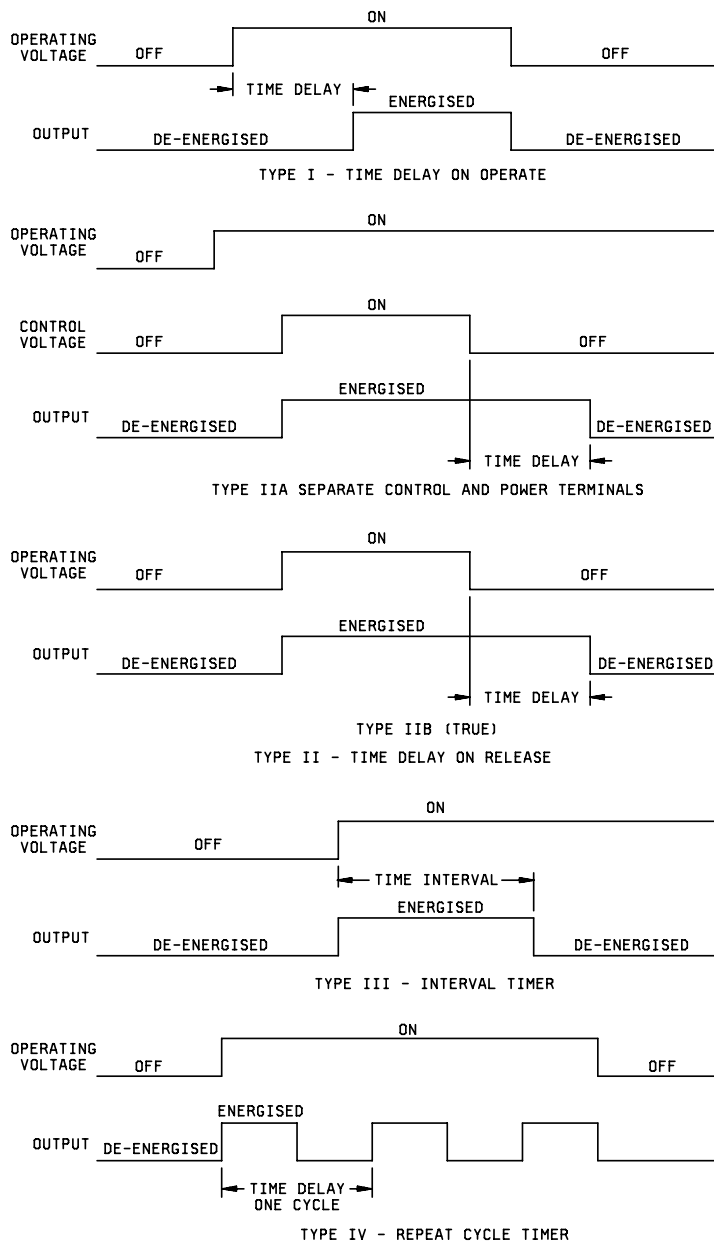

FIGURE 4. Relay timing diagrams.

MIL-PRF-83726D

6.11 Subject term (key word) listing.

Timing cycle  
Leakage current  
Zero crossover  
Repeat cycle timer  
Interval timer

6.12 Environmentally preferable material. Environmentally preferable materials should be used to the maximum extent possible to meet the requirements of this specification. As of the dating of this document, the U.S. Environmental Protection Agency (EPA) is focusing efforts on reducing [31 priority chemicals](http://www.epa.gov/osw/hazard/wastemin/priority.htm). The list of chemicals and additional information is available on their website <http://www.epa.gov/osw/hazard/wastemin/priority.htm>. Use of these materials should be minimized or eliminated unless needed to meet the requirements specified herein (see [Section 3](#)).

6.13 Changes from previous issue. The margins of this specification are marked with vertical lines to indicate where changes from the previous issue were made. This was done as a convenience only and the Government assumes no liability whatsoever for any inaccuracies in these notations. Bidders and contractors are cautioned to evaluate the requirements of this document based on the entire content irrespective of the marginal notations and relationship to the last previous issue.

## MIL-PRF-83726D

## APPENDIX A

## SOLDER DIP AND RETINNING REQUIREMENTS

## A.1 SCOPE

A.1.1 Scope. This appendix establishes additional requirements for the QPL system for time delay relays. It describes the process for solder dip (retinning) leads if the manufacturer chooses the option as identified in 3.6.12.3. The manufacturer shall maintain and demonstrate this system to the qualifying activity as prerequisite for qualification and retention of qualification. This system shall be part of the overall QPL system under MIL-STD-790. Appendix A is a mandatory part of this specification. The information contained herein is intended for compliance.

## A.2 APPLICABLE DOCUMENTS

A.2.1 General. The documents listed in this section are specified in sections 3 and 4 of this specification. This section does not include documents cited in other sections of this specification or recommended for additional information or as examples. While every effort has been made to ensure the completeness of this list, document users are cautioned that they must meet all specified requirements of documents cited in sections 3 and 4 of this specification, whether or not they are listed.

A.2.2 Government documents.

A.2.2.1 Specifications, standards, and handbooks. The following specifications, standards, and handbooks form a part of this document to the extent specified herein. Unless otherwise specified, the issues of these documents are those cited in the solicitation or contract.

## DEPARTMENT OF DEFENSE STANDARDS

[MIL-STD-1276](#) - Leads for Electronic Component Parts.

(Copies of these documents are available online at <http://assist.daps.dla.mil/> or from the Standardization Document Order Desk, 700 Robbins Avenue, Building 4D, Philadelphia, PA 19111-5094.)

A.2.3 Order of precedence. In the event of a conflict between the text of this document and the references cited herein (except for related specification sheets), the text of this document takes precedence unless otherwise noted. Nothing in this document, however, supersedes applicable laws and regulations unless a specific exemption has been obtained.

## A.3 REQUIREMENTS

A.3.1 Solder dip (retinning) leads.

A.3.1.1 Solder dip (retinning) leads (not applicable to terminal L). Only the manufacturer, at their option, may solder dip/retin the leads of product supplied to this specification provided the solder dip process (see A.3.1.1.1) or equivalent process has been approved by the qualifying activity.



## MIL-PRF-83726D

## APPENDIX A

A.3.1.1.1 Qualifying activity approval. Approval of the solder dip process will be based on one of the following options:

- a. When the original terminal finish qualified was hot solder dip terminal finish 52 of [MIL-STD-1276](#) (The 200 microinch thickness is not applicable.), the manufacturer shall use the same solder dip process for retooling as was used in the original manufacture of the product.
- b. When the terminal originally qualified was not hot solder dip terminal finish 52 as prescribed above, approval for the process to be used for solder dip shall be based upon the following test procedure:
  - (1) Six samples for each style and terminal finish shall be subjected to the manufacturer's solder dip process. Following the solder dip process, the relays shall be subjected to group A2 and group A4.
  - (2) Three of six samples shall then be subjected to the solderability test (see [3.8](#)). No visual defects are allowed.
  - (3) The remaining three samples shall be subjected to the resistance of soldering heat test (see [3.28](#)).
  - (4) All six (6) samples shall be subjected to group A2 and group A4, less screening. Minor scratching of the terminals due to insertion into test sockets shall not be cause for rejection.

A.3.1.1.2 Solder dip/retooling options. The manufacturer may solder dip/retool as follows:

- a. After group A2 and before group A3. Following the solder dip/retooling process, insulation resistance (all terminals to case), seal, and visual/mechanical inspection shall be performed.
- b. As a corrective action, if the lot fails the group A solderability test, insulation resistance (all terminals to case), seal, and visual/mechanical inspection shall be performed.
- c. For relays that have been subjected to and passed group A inspection. Following the solder dip/retooling process, insulation resistance (all terminals to case), seal and visual/mechanical inspection shall be performed.

MIL-PRF-83726D

Custodians:

Army - CR  
Navy - EC  
Air Force - 85  
DLA - CC

Preparing activity:

DLA - CC

(Project 5945-2008-021)

Review activities:

Navy - TD  
Air Force - 99

NOTE: The activities listed above were interested in this document as of the date of this document. Since organizations and responsibilities can change, you should verify the currency of the information above using the ASSIST Online database at <http://assist.daps.dla.mil/>.