

INCH-POUND

MIL-PRF-83178C  
18 May 2009  
 SUPERSEDING  
 MIL-PRF-83178B  
 24 September 1999

## PERFORMANCE SPECIFICATION

### REGULATOR, OXYGEN, DILUTER-DEMAND, AUTOMATIC-PRESSURE-BREATHING, CRU-73A, GENERAL SPECIFICATION FOR

This specification is approved for use by all Departments and Agencies of the Department of Defense.

#### 1. SCOPE

1.1 Scope. This specification covers the general requirements for a panel mounted automatic-pressure-breathing, diluter-demand, oxygen regulator, designated CRU-73A.

#### 1.2 Classification.

1.2.1 Panel lighting. There are three panel lighting configurations of the regulator, see the list on figure 1.

1.3 Part or Identifying Number (PIN). The PIN to be used for the regulators acquired to this specification, are created as follows. M83178 dash numbers supersede MS27599 dash numbers.

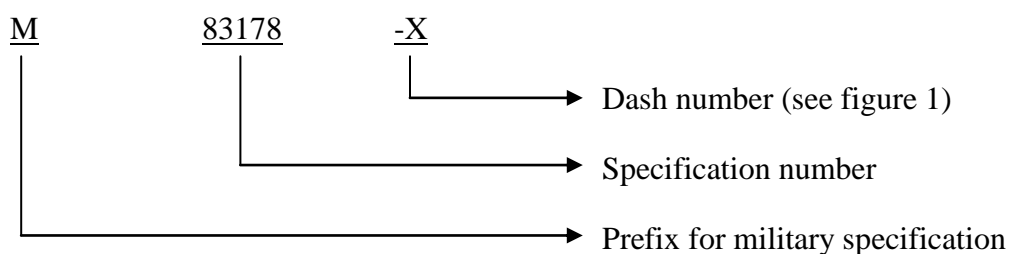

Comments, suggestions, or questions on this document should be addressed to Oklahoma City Air Logistics Center/ENSDAA, 3001 Staff Drive, Tinker AFB, OK 73145-3036 or emailed to [af71@tinker.af.mil](mailto:af71@tinker.af.mil). Since contact information can change, you may want to verify the currency of this address information using the ASSIST Online database at <http://assist.daps.dla.mil>.

## MIL-PRF-83178C

## 2. APPLICABLE DOCUMENTS

2.1 General. The documents listed in this section are specified in sections 3, 4, and 5 of this specification. This section does not include documents cited in other sections of this specification or recommended for additional information or as examples. While every effort has been made to ensure the completeness of this list, document users are cautioned that they must meet all specified requirements of the documents cited in sections 3, 4, and 5 of this specification, whether or not they are listed.

2.2 Government documents.

2.2.1 Specifications and standards. The following specifications and standards form a part of this document to the extent specified herein. Unless otherwise specified, the issues of these documents are those cited in the solicitation or contract.

## FEDERAL SPECIFICATIONS

BB-A-1034 - Compressed Air, Breathing

## FEDERAL STANDARDS

FED-STD-595/37038 - Miscellaneous, Flat or Lusterless

## COMMERCIAL ITEM DESCRIPTIONS

A-A-59503 - Nitrogen, Technical

## DEPARTMENT OF DEFENSE SPECIFICATIONS

MIL-DTL-6363/8 - Lamps, Incandescent Aircraft Service, Single Contact, Midget Flanged Base, T-1 ¾ Bulb  
 MIL-F-25173 - Fastener, Control Panel, Aircraft Equipment  
 MIL-G-25520 - Gage, Pressure, Dial Indication, Oxygen 0-500 psi, Type MF-3

## DEPARTMENT OF DEFENSE STANDARDS

MIL-STD-461 - Requirements for the Control of Electromagnetic Interference Characteristics of Subsystems and Equipment

(Copies of these documents are available online at <http://assist.daps.dla.mil/> or from the Standardization Document Order Desk, 700 Robbins Avenue, Building 4D, Philadelphia, PA 19111-5094.)

MIL-PRF-83178C

2.2.2 Other government documents, drawings, and publications. The following other government documents, drawings, and publications form a part of this document to the extent specified herein. Unless otherwise specified, the issues are those cited in the solicitation or contract.

TECHNICAL MANUAL

TO 15X-1-1 - Maintenance Instructions, Oxygen Equipment

(For information to obtain copies of this document contact OC-ALC/ENGLA Bldg 3, Room 203, Tinker AFB OK 73145-9147. Commercial telephone: 405 736-2466.)

2.3 Non-government publications. The following documents form a part of this document to the extent specified herein. Unless otherwise specified, the issues of these documents are those cited in the solicitation or contract.

ASME INTERNATIONAL

ANSI/ASME-B1.20.1 - Pipe Threads, General Purpose (Inch) (DoD adopted)

(ASME documents may be obtained online at <http://www.asme.org/> or addressed to ASME International, Three Park Ave., M/S 10E, New York NY 10016-5990.)

ASTM INTERNATIONAL

ASTM-B117 - Standard Practice for Operating Salt Spray (Fog) Apparatus (DoD adopted)

ASTM-D1149 - Standard Test Method for Rubber Deterioration-Cracking in a Ozone Controlled Environment (DoD adopted)

(ASTM documents may be obtained online at [www.astm.org](http://www.astm.org) or addressed to the American Society for Testing and Material, 100 Barr Harbor Drive, West Conshohocken, PA 19428-2959.)

AMERICAN SOCIETY FOR QUALITY (ASQ)

ANSI/ASQ Z1.4 - Sampling Procedures and Tables for Inspection by Attributes (DoD-adopted)

(ASQ documents may be obtained online at <http://www.asq.org/> or addressed to the American Society for Quality, P.O. Box 3005, Milwaukee, WI 53201-3005 or 600 North Plankinton Avenue, Milwaukee, WI 53203.)

## MIL-PRF-83178C

## SAE INTERNATIONAL

SAE-AS1065	- Quality and Serviceability Requirements for Aircraft Cylinder Assemblies Charged with Aviator's Breathing Oxygen
SAE AS 7788	- Panels, Information Integrally Illuminated (DoD adopted)
SAE-AS8010	- Aviator's Breathing Oxygen Purity Standard

(SAE documents may be obtained online at <http://www.sae.org/> or addressed to the Society of Automotive Engineers, Inc., 400 Commonwealth Drive, Warrendale, PA 15096-0001.)

2.4 Order of precedence. Unless otherwise noted herein or in the contract, in the event of a conflict between the text of this document and the references cited herein, the text of this document takes precedence. Nothing in this document, however, supersedes applicable laws and regulations unless a specific exemption has been obtained.

### 3. REQUIREMENTS

3.1 Qualification. The regulators furnished under this specification shall be products that are authorized by the qualifying activity for listing on the applicable qualified products list before contract award (see 6.3).

3.2 Recycled, recovered, or environmentally preferable materials. Recycled, recovered, or environmentally preferable materials should be used to the maximum extent possible, provided that the material meets or exceeds the operational and maintenance requirements, and promotes economically advantageous life cycle costs.

3.3 Cleanliness. All surfaces shall be free of visible particulates (50 microns and larger), free of visible fluorinated lubricants, and free of hydrocarbon contamination to a level not greater than 3 milligrams per square foot (mg/ft<sup>2</sup>) (see 6.6).

3.4 Materials. All materials shall be corrosion resistant or suitably treated to resist corrosion due to electrolytic decomposition, salt air, and any other atmospheric conditions that may be encountered during operational use or storage. The use of toxic chemicals, hazardous substances, or ozone depleting chemicals shall be avoided, whenever feasible.

3.4.1 Safety specific materials. All materials used shall be capable of operating in pure oxygen environment without creating a health or fire hazard (see 6.8).

3.4.2 Nonferrous materials. Except where essential, ferrous materials shall not be used.

3.4.3 Elastomers. Elastomers shall be of an ozone-resistant composition (see 6.12). Polyvinyl chloride shall not be used.

## MIL-PRF-83178C

3.4.4 Finish. Unless otherwise specified in this specification, regulator surfaces shall not be painted.

3.5 Interface.

3.5.1 Regulator surfaces. Regulator surfaces visible after installation, the test ports, and the test port cap shall be flat black, color number 37038 of FED-STD-595.

3.5.2 Regulator panel. The panel shall conform to SAE-AS7788 and the panel marking shall conform to figures 1 and 3. The background color of the panel shall be flat black, color number 37038 of FED –STD-595.

3.5.3 Flow indicator. A flow indicator, conforming to figure 1, shall be provided on the regulator panel and shall show white when oxygen is flowing.

3.5.4 Pressure gage. The regulator panel shall be provided with a pressure gage conforming to MIL-G-25520. The pressure gage shall indicate oxygen system pressure with the supply lever in either the on or off position.

3.5.5 Pipe threads. Pipe threads shall conform to ANSI/ASME-B1.20.1.

3.5.6 Dimensions. The regulator shall conform to dimensions shown on figures 1, 2, 4, 5, and 6.

3.5.7 Panel fasteners. Panel fasteners shall conform to MIL-F-25173 (see figures 1 and 2).

3.5.8 Test ports. The regulator shall incorporate test ports on the panel conforming to figure 5. Test ports shall not obstruct the view of the flow indicator and pressure gage. With a pressure altitude of 34,000 feet applied to the pressure breathing test port, the regulator shall deliver an outlet pressure between 1.0 to 3.5 inches of water. With a pressure altitude of 43,000 feet applied to the pressure breathing test port, the regulator shall deliver an outlet pressure between 4.5 to 10.0 inches of water (see 6.10). At a pressure altitude between 27,000 and 32,000 feet, the air mixing valve and air inlet test port check valve shall close, and the added oxygen ratio shall be as specified (see 3.6.11). Vacuum applied to the pressure breathing test port shall not be applied to the main body of the regulator. With the diluter lever in the 100% oxygen position and a vacuum of 4 inches of water applied to the pressure breathing test port, the leakage from the pressure breathing test port shall be less than 0.02 liters per minute (LPM).

3.5.9 Supply lever coloring. The lever coloring shall conform to figure 1.

3.5.10 Diluter lever coloring. The lever coloring shall conform to figure 1.

3.5.11 Pressure lever coloring. The pressure lever coloring shall conform to figure 1.

3.6 Performance.

## MIL-PRF-83178C

3.6.1 Air mixing port. An air mixing port shall be provided to mix varying quantities of ambient air with oxygen in specified ratios. A filter equivalent to a mesh screen within a range of 30 to 100 mesh, shall be provided to prevent foreign particles from entering the regulator.

3.6.2 Oxygen inlet filter. A 30 micron filter shall be provided at the regulator inlet.

3.6.3 Pressure relief device. A replaceable pressure relief device shall be provided to vent excess outlet pressure through the body of the regulator to the atmosphere. The device shall vent 45 liters per minute (LPM) at a pressure not exceeding 2 inches of mercury. The device leak rate shall not exceed 0.02 LPM at a pressure of 17 inches of water.

3.6.3.1 Pressure relief device high temperature exposure. The pressure relief device shall operate as specified after exposure to  $250^{\circ} \pm 5^{\circ}\text{F}$ .

3.6.3.2 Pressure relief device cycling. The pressure relief device shall operate as specified after being cycled from closed to open and back to closed 50 times.

3.6.4 Pressure breathing test port. The pressure breathing test port (see figure 5) shall be provided with a 20 micron filter.

3.6.4.1 Air inlet test port. A force of  $2.5 \pm 1.0$  pounds shall be required to activate the air inlet test port check valve (see figure 5). The air inlet port shall be provided with a cap and tether.

3.6.5 Supply control.

3.6.5.1 Supply lever. A lever shall be provided on the regulator panel to activate the supply valve to shut off the oxygen supply when the regulator is not in use. The supply lever shall have on and off positions. With the supply lever in the off position, the air mixing port shall be closed.

3.6.5.2 Supply lever activation. The regulator shall operate as specified herein after the supply valve has been cycled from open to closed and back to open 1,000 times. A force of  $53 \pm 37$  ounces shall be required to move the supply lever to either position. The supply lever shall not stop between the on and off positions (see 6.9).

3.6.6 Diluter control.

3.6.6.1 Diluter lever. A lever shall be provided on the regulator panel to control the air mixing port. The air mixing port shall enable the regulator to deliver either diluted oxygen or pure oxygen (see 3.6.11). The diluter lever shall have normal oxygen and 100% oxygen positions.

3.6.6.2 Diluter lever activation. A force of  $33 \pm 17$  ounces shall be required to move the diluter lever to either position. Stops shall be provided at the normal oxygen and 100% oxygen positions. The diluter lever shall not stop between the normal oxygen and 100% oxygen positions.

## MIL-PRF-83178C

3.6.7 Pressure control.

3.6.7.1 Pressure lever. A lever shall be provided on the regulator panel to ensure that a positive pressure may be obtained at the regulator outlet at altitudes where automatic positive pressure is not delivered. The pressure lever shall have emergency, normal, and test mask positions.

3.6.7.2 Pressure lever activation. A force of  $33 \pm 17$  ounces shall be required to move the pressure lever from the normal to emergency positions. A force of  $53 \pm 37$  ounces shall be required to move the pressure lever from the normal to the test mask position. When released from the test mask position, the pressure lever shall return to normal position. The pressure lever shall not stop between emergency, normal, or test mask positions.

3.6.8 Tester compatibility. The regulator shall meet the test requirements of TO 15X-1-1 using the Tester, Pressure Breathing, Gaseous (PBG) Oxygen Regulator, Field (pneumatic) (see 6.8).

3.6.9 Excess flow characteristics. The regulator shall withstand an excess flow characteristic produced by holding the pressure lever in the test mask position for 2 seconds.

3.6.10 Flow suction characteristics. With either increasing or decreasing suction applied to the outlet, the supply Pressure as shown, and the diluter lever in either the normal oxygen or 100% oxygen positions, the outlet pressure required to obtain the listed flow rate at the given pressure altitude range shall conform to table I (see 6.8 and 6.11).

3.6.11 Added oxygen. The ratio (by volume) of oxygen added by the regulator from the oxygen system to total gas delivered through the outlet shall conform to table II (see 6.13).

3.6.12 Pressure breathing characteristics. With either increasing or decreasing flow, and the diluter lever in the normal oxygen position, the pressure breathing characteristics of the regulator shall be within the limits specified in table III. A means shall be provided to prevent negative pressure within oxygen mask at altitudes between 30,000 and 40,000 feet (see 6.8).

TABLE I. Flow suction characteristics

Supply pressure (psig)	Outlet flow rates (LPM)	Pressure altitude range (X1,000 ft)	Outlet pressure* (inches of water)
50 to 500	0 to 30	0 to 27	-0.45 to 1.0
50 to 500	31 to 50	0 to 27	-0.7 to 1.0
50 to 500	51 to 85	0 to 27	-1.0 to 1.0
50 to 500	86 to 135	10 to 27	-1.0 to 1.0

\* The positive outlet pressure shall apply only for altitudes above 15,000 feet. A suction shall be required to induce a flow of oxygen in excess of 0.01 LPM below 15,000 feet.

## MIL-PRF-83178C

TABLE II. Added oxygen

Pressure Altitude (x1,000 ft)	Ratio of oxygen added with diluter lever in the normal oxygen position (%)			
	1 to 14 LPM	15 to 50 LPM	51 to 85 LPM	86 to 135 LPM
0	0 to 100	0 to 30	0 to 30	-
5	1 to 100	1 to 33	1 to 33	-
10	6 to 100	6 to 35	6 to 27	6 to 35
15	14 to 100	14 to 42	14 to 30	14 to 45
20	24 to 100	24 to 55	24 to 55	24 to 55
25	40 to 100	40 to 80	40 to 80	40 to 90
28	60 to 100	60 to 100	60 to 100	60 to 100
32	98 to 100	98 to 100	98 to 100	98 to 100
	Ratio of oxygen added with diluter lever in 100% oxygen position (%)			
<u>All altitudes</u>	98 to 100	98 to 100	98 to 100	98 to 100

TABLE III. Pressure breathing characteristics

Pressure altitude (x 1,000 ft)	Outlet pressure at 10 LPM (inches of water)
27	-0.45 to 1.0
30	0.01 to 2.5
32	0.01 to 2.8
34	0.01 to 3.0
36	0.01 to 3.2
38	0.01 to 3.4
39	0.30 to 3.5
40	0.30 to 5.6
41	2.00 to 7.2
42	3.40 to 8.6
43	5.30 to 10.2
47	11.20 to 15.3

3.6.12.1 Pressure ranges. With either increasing or decreasing flow, and the diluter lever in the normal oxygen position, the outlet pressure in the given ranges of table III shall meet the tolerances at the flow variations in table IV.



## MIL-PRF-83178C

TABLE IV. Pressure range tolerance

Outlet pressure range (inches of water)	Pressure variation tolerances for flow rate changes from (inches of water)		
	10 to 0 LPM	10 to 70 LPM	10 to 135 LPM
1.0 to 2.0	1.0	-0.9	N/A
2.0 to 15.3	1.3	N/A	-1.3

3.6.13 Static leakage. The regulator static pressure leakage shall be less than 0.01 LPM during a 2 minute period.

3.6.14 Inward leakage. With the diluter lever in the normal oxygen position, the supply lever in the off position, and a suction of 10 inches of water applied at the outlet, the inward leakage through the regulator at a pressure altitude of zero feet shall be less than 0.2 LPM (see 6.8).

3.6.15 Outward leakage. With a pressure of 17 inches of water applied at the outlet of the regulator, outward leakage through the regulator, including the pressure relief device, shall be less than 0.12 LPM.

3.6.16 Outlet leakage. With the supply lever in the on position, the leakage at the outlet of the regulator shall be less than 0.01 LPM.

3.6.17 Supply valve leakage. The supply valve leakage shall be less than 0.001 LPM.

3.6.18 Emergency pressure operation. With the pressure lever in the emergency position and the diluter lever in the normal position, the regulator outlet pressure shall be 3.5  $\pm$ 0.5 inches of water at a flow of 10 LPM. At a flow of 80 LPM, the outlet pressure shall be greater than 2 inches of water.

3.6.19 Test mask position operation. With the pressure lever in the test mask position, the regulator shall provide 10 LPM at a pressure of 11  $\pm$ 5 inches of water at the outlet.

3.6.20 Flow indicator operation. With diluter lever in the 100% oxygen position, the indicator shall provide full flow indication for an outlet flow of 4 LPM at a pressure altitude of zero feet, and an outlet flow of 8 LPM at a pressure altitude of 35,000 feet. With the diluter lever in the normal oxygen position, a full flow indication shall be provided for a flow of 18 LPM at all pressure altitudes. With the flow reduced to 0 LPM, at all pressure altitudes, and the diluter lever in either position, the flow indicator shall show no indication of flow.

3.6.21 Panel lighting. The regulator panel shall be provided with lighting conforming to the table on figure 1 and SAE-AS7788. The panel shall not cause electromagnetic interference.

3.6.22 Overload. With supply lever in the off position and the diluter lever in the 100% oxygen position, the regulator shall withstand a pressure of 27 inches of water applied at the outlet for a period of 2 minutes.

## MIL-PRF-83178C

3.6.23 Maximum inlet pressure. The regulator shall operate as specified at an inlet pressure of 500 psi gage (psig).

3.6.24 Altitude cycling. After 1,000 pressure altitude cycles from 0 to 50,000 feet and back to zero feet, the regulator shall operate as specified.

3.6.25 Odor. The regulator shall be odorless.

3.6.26 Orientation. The regulator shall operate as specified in any orientation except with the panel facing down. In this orientation, the outlet pressures for altitudes from 27,000 to 50,000 feet allowed 1.5 inches of water greater than the maximum specified in table III.

3.6.27 Reliability. The regulator shall have a mean cycle between failures (MCBF) of not less than 700,000 cycles (see 6.8).

3.6.28 Operating life span. The regulator shall have a operating life span of not less than 2,700,000 cycles (see 6.8).

3.6.29 Weight. The weight of the regulator shall be less than 3 pounds.

3.7 Identification. The regulator shall be permanently and legibly marked with the following (see 6.2):

- a. Nomenclature.
- b. Serial Number.
- c. PIN.
- d. National stock number.
- e. Contract number.
- f. Manufacturer's CAGE code.
- g. Manufacturer's part number.
- h. Date of manufacture.

3.8 Interchangeability. All parts having the same manufacturer's part number shall be functionally and dimensionally interchangeable.

3.9 Temperature conditions. The regulator shall operate as specified from -65° to 160°F, and shall operate as specified after exposure to temperatures from -85° to 200°F.

#### 4. VERIFICATION

4.1 Classification of inspections. The inspection requirements specified herein are classified as follows:

- a. Qualification inspection (see 4.2).
- b. Conformance inspection (see 4.3).

## MIL-PRF-83178C

4.2 Qualification inspection. Qualification inspection shall be performed on two regulators. The qualification inspection shall consist of the tests described in 4.6. At least one regulator shall be subjected to the operating life span test.

4.3 Conformance inspection. Conformance inspection shall include the individual tests in 4.3.1 and the sampling tests in 4.3.2.

4.3.1 Individual tests. Each regulator shall be subjected to the following tests.

- a. Examination (see 4.6.1).
- b. Excess flow characteristics (see 4.6.2).
- c. Flow suction characteristics (see 4.6.3).
- d. Added oxygen (see 4.6.4).
- e. Pressure breathing characteristics (see 4.6.5).
- f. Pressure relief device (see 4.6.6).
- g. Static leakage (see 4.6.8).
- h. Inward leakage (see 4.6.9).
- i. Outward leakage (see 4.6.10).
- j. Outlet leakage (see 4.6.11).
- k. Supply valve leakage (see 4.6.12).
- l. Emergency pressures (see 4.6.13).
- m. Test mask pressures (see 4.6.14).
- n. Flow indicator operation (see 4.6.15).
- o. Panel lighting (see 4.6.16).
- p. Test port altitude operations (see 4.6.17).
- q. Pressure breathing test port leakage (see 4.6.18).

4.3.2 Sampling tests. Sampling tests shall be performed in accordance with the guidance in ANSI/ASQ Z1.4. Sampling shall begin at the normal inspection level (see 6.4). The sampling tests are:

- a. Overload (see 4.6.19).
- b. Maximum inlet pressure (see 4.6.20).
- c. Altitude cycling (see 4.6.21).
- d. Supply valve cycling (see 4.6.24).
- e. Pressure relief device cycling (see 4.6.26).
- f. Low temperature operation (see 4.6.27).
- g. High temperature operation (see 4.6.28).
- h. lever operating force (see 4.6.31).
- i. Reliability test (see 4.6.34).

4.4 Test conditions. Unless otherwise specified in the test descriptions, all inspections shall be performed in accordance with the test conditions specified in the applicable test method documents applicable paragraphs in this specification.

- a. Tests shall be performed at ambient atmospheric conditions.

## MIL-PRF-83178C

- b. The tests gas shall be oxygen conforming to SAE-AS8010; water pumped nitrogen conforming to Type I, Class 1, Grade B of A-A-59503; or water pumped dry air conforming to BB-A-1034, Source I, Grade A, or Source II, Grade A.
- c. The inlet test pressure shall be 50 psig.
- d. The regulator shall be tested with the panel mounted in the horizontal plane with the face up.

4.5 Requirements cross-reference matrix. Table V provides a cross-reference matrix of the section 3 requirements tested or verified in the paragraphs below.

TABLE V. Requirements cross-reference matrix

Requirement	Verification	Requirement	Verification
3.1	4.2	3.6.7.2	4.6.1
3.3	4.6.1, 4.6.33	3.6.7.3	4.6.31
3.4	4.6.1, 4.6.32	3.6.8	4.6.38
3.4.1	4.6.1, 4.6.2, 4.6.3, 4.6.5	3.6.9	4.6.2
3.4.2	4.6.1	3.6.10	4.6.3
3.4.3	4.6.1, 4.6.36	3.6.11	4.6.4
3.4.4	4.6.1	3.6.12	4.6.5
3.5.1	4.6.1	3.6.12.1	4.6.5
3.5.2	4.6.1, 4.6.15	3.6.13	4.6.8
3.5.3	4.6.1, 4.6.24	3.6.14	4.6.9
3.5.4	4.6.1	3.6.15	4.6.10
3.5.5	4.6.1	3.6.16	4.6.11
3.5.6	4.6.1	3.6.17	4.6.12
3.6.1	4.6.1, 4.6.4	3.6.18	4.6.13
3.6.2	4.6.1	3.6.19	4.6.14
3.6.3	4.6.1, 4.6.6, 4.6.7	3.6.20	4.6.15
3.6.3.1	4.6.7	3.6.21	4.6.16, 4.6.37
3.6.3.2	4.6.26	3.6.22	4.6.19
3.6.4	4.6.1, 4.6.17, 4.6.18	3.6.23	4.6.20
3.6.4.1	4.6.1	3.6.24	4.6.21
3.6.4.2	4.6.1, 4.6.38	3.6.25	4.6.22
3.6.5.1	4.6.1, 4.6.12	3.6.26	4.6.23
3.6.5.2	4.6.1	3.6.27	4.6.34
3.6.5.3	4.6.24, 4.6.25, 4.6.31	3.6.28	4.6.35
3.6.6.1	4.6.1, 4.6.4	3.6.29	4.6.1
3.6.6.2	4.6.1	3.7	4.6.1
3.6.6.3	4.6.31	3.8	4.6.1
3.6.7.1	4.6.1, 4.6.5, 4.6.13, 4.6.14	3.9	4.6.27, 4.6.28, 4.6.29, 4.6.30

## MIL-PRF-83178C

## 4.6 Tests.

4.6.1 Examination. The regulator shall be examined to determine that materials, interface, dimensions, weight, identification, filters, caps fasteners, cleanliness, and interchangeability conform to this specification (see 6.5).

4.6.2 Excess flow characteristics. With an inlet pressure of 500 psig, no hose connected to the outlet, and the pressure lever held in the test mask position for 2 seconds, the regulator shall have no evidence of internal vibration or noise.

4.6.3 Flow suction characteristics. With either increasing or decreasing flows and at a pressure altitude of 0 feet, the outlet pressure required to produce the specified flow rate with the diluter lever in both the normal oxygen and 100% oxygen positions shall conform to characteristics in table VI. After the suction is reduced to 0 inches of water, the leakage shall be less than 0.01 LPM.

TABLE VI. Flow suction characteristics

Supply pressure (psig)	Outlet flows (LPM)	Outlet pressure (inches of water)
50	2	-0.40 to 0.0
50	30	-0.45 to 0.0
50	50	-0.70 to 0.0
50	85	-1.00 to 0.0
500	85	-1.00 to 0.0

4.6.4 Added oxygen. With the diluter lever in the normal position and at the pressure altitudes and outlet flows listed in table VII, the ratio (by volume) of oxygen added by the regulator to the total gas delivered through the outlet shall conform to table VII. With the diluter lever in the 100% oxygen position, the ratio of oxygen added for specified flows shall be 98 to 100% at all altitudes.

TABLE VII. Added oxygen

Pressure altitude (x 1,000 ft)	Outlet flow LPM	Oxygen ratio (%)
0	10	0 to 100
10	15	6 to 35
10	50	6 to 35
10	135	6 to 35
15	5	14 to 100
15	15	14 to 42
15	85	14 to 30
20	15	24 to 55
20	50	24 to 55
20	135	24 to 55

## MIL-PRF-83178C

25	5	40 to 100
25	15	40 to 80
25	85	40 to 80
32	135	98 to 100

4.6.5 Pressure breathing characteristics. With the supply lever in the on position, the diluter lever in the normal oxygen position, and the pressure altitude at the value listed in table VIII, an outlet flow of 10 LPM shall established within the outlet pressure range listed in table VIII. The pressure variation tolerances associated with the listed outlet flow variation from 10 LPM shall conform to table VIII. With an outlet flow 10 LPM and a pressure altitude in the range of 30,000 to 38,000 feet, the outlet pressure shall not fall below 0.01 inch of water. With an outlet flow of 70 LPM and a pressure altitude in the range of 34,000 to 40,000 feet, the outlet pressure shall not fall below 0.01 inch of water.

TABLE VIII. Pressure breathing characteristics

Pressure altitude (x 1,000 ft)	Outlet pressure range at 10 LPM (inches of water)	Maximum pressure increase at 0 LPM (inches of water)	Maximum outlet pressure decrease at indicated flow (inches of water)
30	0.01 to 2.5	1.0	0.9 for 70 LPM
34	0.01 to 3.0	1.3	1.3 for 135 LPM
43	5.30 to 10.2	1.3	1.3 for 135 LPM
47	11.20 to 15.3	1.3	1.3 for 135 LPM

4.6.6 Pressure relief device. With the supply lever in the off position, the diluter in the 100% oxygen position, and the pressure lever in the normal position, a pressure of 17 inches of water shall be applied to the regulator outlet. The pressure relief device leak rate shall not exceed 0.02 LPM. With a pressure of 2 inches of mercury applied to the regulator outlet, the flow rate of the pressure relief device shall be greater than 45 LPM. With the pressure at the regulator outlet stabilized back at 17 inches of water and a flow of 0 LPM, the pressure relief device leak rate shall not exceed 0.02 LPM.

4.6.7 Pressure relief device high temperature exposure. After being removed from the regulator and subjected to a temperature of  $250^{\circ} \pm 5^{\circ}\text{F}$  for 7 hours and then returned to room temperature the pressure relief device shall be subjected to the pressure relief device test specified in 4.6.6.

4.6.8 Static leakage. The regulator shall be subjected to a static pressure with an inlet pressure of 500 psig. The leak rate during a 2 minute period shall be less than 0.01 LPM.

4.6.9 Inward leakage. With the supply lever first in the on position, the diluter lever in the normal oxygen position, and the pressure lever in the normal position, the supply lever shall be moved to the off position thereby automatically moving the diluter lever to 100% oxygen position. Then a suction of 10 inches of water shall be applied at the outlet of the regulator, and the regulator leakage shall be less than 0.20 LPM.

## MIL-PRF-83178C

4.6.10 Outward leakage. With the supply lever in the off position the pressure lever in the normal position, and the pressure relief device uncapped, a pressure of 17 inches of water shall be applied to the outlet of the regulator. The leakage through the regulator shall not exceed 0.12 LPM.

4.6.11 Outlet leakage. With the supply lever in the on position and the pressure lever in the normal position, the regulator outlet leakage shall be less than 0.01 LPM.

4.6.12 Supply valve leakage. With an oxygen inlet pressure of 500 psig, the supply lever in the off position and the pressure lever in the emergency position, the regulator leakage shall be less than 0.001 LPM.

4.6.13 Emergency pressures. With the supply in the on position and the diluter lever in the normal oxygen position, a flow of 10 LPM shall be established at the outlet of the regulator. Then the pressure lever shall be placed in the emergency position and the outlet pressure shall be  $3.5 \pm 0.5$  inches of water. With the diluter lever in the 100% oxygen position and a flow of 80 LPM, the outlet pressure shall be greater than 2 inches of water.

4.6.14 Test mask pressures. With the supply lever in the on position, the diluter lever in the normal oxygen position, and the pressure lever held in the test mask position, the regulator shall deliver an outlet flow of 10 LPM with an outlet pressure of  $11 \pm 5$  inches of water.

4.6.15 Flow indicator operation. With the diluter lever in the 100% oxygen position and a flow of 4 LPM at a pressure altitude of zero feet, the flow indicator shall indicate full flow and the flow indicator shall show white. With the diluter lever in the 100% oxygen position and a flow of 8 LPM at a pressure altitude of 35,000 feet, the flow indicator shall indicate full flow. With the diluter lever in the normal oxygen position and a flow of 18 LPM, the flow indicator shall indicate full flow at all altitudes. When the flow is reduced to 0 LPM for all altitudes, the flow indicator shall show no indication of flow.

4.6.16 Panel lighting. The regulator shall be connected to a power source as specified in the acquisition document and test in accordance with SAE-AS7788 (see 6.2).

4.6.17 Test port altitude operations. With the supply lever in the on position and the diluter lever in the normal position, a vacuum shall be applied in the pressure breathing test port. The outlet shall be vented to the atmosphere through an orifice set to deliver 5 LPM at 10 inches of water. At a pressure altitude of 34,000 feet, the outlet pressure shall be 1.0 to 3.5 inches of water, and at a pressure altitude of 43,000 feet, the outlet pressure shall be 4.5 to 10.0 inches of water.

4.6.17.1 Test port shut-off altitude operations. After completion of the test port altitude operations test, the supply lever shall be moved to the off position, automatically forcing the diluter to 100% oxygen position. The pressure lever shall be in the normal position. An altimeter shall be connected to the air inlet test port and a vacuum, not to exceed 45,000 feet, shall be applied at the pressure breathing test port. At a pressure altitude between 27,000 to 32,000 feet, the air inlet mixing device shall close causing 100% oxygen ratio. With vacuum continued for a

## MIL-PRF-83178C

5 second period, the shut-off altitude shall not change more than that equal to a 21 millimeters of mercury vacuum decay of a given volume equal to the volume of PBG field tester. With the supply lever in the off position and the diluter lever in the 100% oxygen position, the suction required at the outlet to draw 0.2 LPM through the air inlet test port shall not exceed 0.8 inch of water. It shall be possible to perform these operations using a vacuum source with a capacity of 80 cubic inches per minute at 32 inches of mercury absolute discharge pressure and 6.2 inches of mercury absolute inlet pressure. The regulator shall then be subjected to the flow suction and pressure breathing tests.

4.6.18 Pressure breathing test port leakage. With the diluter lever in the 100% position, a vacuum of 4 inches of water shall be applied to the pressure breathing test port. The leakage shall be less than 0.02 LPM.

4.6.19 Overload. With supply lever in the off position and with the diluter lever in the 100% oxygen position, a pressure of 27 inches of water shall be applied at the outlet of the regulator for a period of 2 minutes. Venting of the pressure relief device is permissible. After the overload conditions, the regulator shall be subjected to the excess flow characteristics, flow suction characteristics, oxygen ratio, and pressure breathing characteristics tests.

4.6.20 Maximum inlet pressure. With an inlet pressure of 500 psig, the regulator shall be subjected to the flow suction characteristics (see 4.6.3), oxygen ratio (see 4.6.4), pressure breathing characteristics (see 4.6.5), emergency pressure (see 4.6.13), test mask pressure (see 4.6.14), and flow indicator operation tests (see 4.6.15).

4.6.21 Altitude cycling. With the diluter and pressure levers in the normal positions, the regulator shall be subjected to 1,000 altitude cycles from 0 to 50,000 feet and back to 0 ft with a rate of altitude change of 2,000 to 2,500 feet per minute. During the altitude cycles, the regulator shall operate at an outlet flow cycle of 5 to 30 LPM and back to 5 LPM at a rate of no more than 60 cycles per minute (cpm). The regulator shall then be subjected to the individual tests.

4.6.22 Odor. With the diluter lever in the 100% oxygen position and the pressure lever in the normal position, oxygen conforming SAE-AS8010 shall be flowed through the regulator at 10 LPM for 2 minutes. The regulator shall be tested for odor in accordance with SAE-AS1065.

4.6.23 Orientation. The regulator shall be subjected to the individual tests with the panel facing up, the panel facing down, and with the panel facing forward, backward, or sideward. When tested with the panel facing down, the regulator outlet pressure from 27,000 feet to 50,000 feet shall be allowed to be 1.5 inches of water greater than the maximum pressures specified in table III.

4.6.24 Supply valve cycling. With an inlet pressure of 50 psig, the supply lever shall be cycled from on to off and back to on 1,000 times. The diluter lever shall move to the 100% oxygen position or the air mixing port shall be automatically closed each time the supply lever is cycled to the off position. With the supply lever in either the on or off position the pressure gag shall indicate the system pressure. After the 1,000 cycles, the regulator shall be subjected to the supply valve leakage test.



## MIL-PRF-83178C

4.6.25 Supply valve actuation. With the diluter and pressure levers in the normal positions, this test shall be run at both 50 psig and 500 psig inlet pressures. The supply lever shall be released from a position that is a minimum of one quarter of the full travel from the off position. The supply lever, when released, shall automatically move to either the full on or off position (see 6.9).

4.6.26 Pressure relief device cycling. With an inlet of 50 psig, the pressure at the outlet shall be cycled from 0 to a pressure of 2 inches of mercury to activate the pressure relief device and back to 0 inches of mercury. This cycle shall be repeated 50 times. The regulator shall then be subjected to the individual tests specified in 4.3.1, except examination and panel lighting tests.

4.6.27 Low temperature operation. With an inlet pressure of  $70 \pm 5$  psig, the regulator shall be stabilized at a temperature of  $-65^{\circ}\text{F}$ . While the temperature is maintained, the regulator shall be operated for a period of 2 minutes. The operation shall consist of 10 cpm, each cycle consisting of a flow of 0 to 70 LPM and back to 0 LPM. The test gas shall be maintained at  $-65^{\circ}\text{F}$  throughout this test. Following this operation, and while still at  $-65^{\circ}\text{F}$ , the regulator shall be subjected to the flow suction characteristics, oxygen ratio, and pressure breathing characteristics tests. An outlet suction of 0.10 inch of water greater than the maximum suction specified in table VI is allowed during this test.

4.6.28 High temperature operation. With an inlet pressure of  $70 \pm 5$  psig, the regulator shall be stabilized at a temperature of  $160^{\circ}\text{F}$ . While the temperature is maintained, the regulator shall be operated for a period of 2 minutes. The operation shall consist of 10 cpm, each cycle consisting of a flow from 0 to 70 LPM, and back 0 LPM. Following this operation and while still at  $160^{\circ}\text{F}$ , the regulator shall be subjected to the flow suction characteristics, oxygen ratio, and pressure breathing characteristics tests.

4.6.29 Low temperature exposure. The regulator shall be subjected to a temperature of  $-85^{\circ}\text{F}$  for 48 hours. After 48 hours, the regulator shall be allowed to return to room temperature and subjected to the individual tests.

4.6.30 High temperature exposure. While maintaining an inlet pressure of 500 psig and with the oxygen supply lever in the on position, the regulator shall then be subjected to a temperature of  $200^{\circ}\text{F}$  for 7 hours. The regulator shall then be allowed to return to room temperature and subjected to the flow characteristics, oxygen ratio, and pressure breathing characteristics tests.

4.6.31 Lever operating force. The lever operating force test shall be performed at both 50 psig and 500 psig inlet pressures. The operating force shall be measured not more than 0.125 inch from the lever tip, in the direction of the intended movement, and parallel to the regulator panel. The operating force of the supply lever movement and the pressure lever movement to the test mask position shall be  $53 \pm 37$  ounces. The pressure lever shall return to the normal position after being released from the test mask position. The operating force of the diluter lever movement and the pressure lever movement between the normal and emergency positions shall be  $33 \pm 17$  ounces. The diluter lever shall not stop between the normal and 100% oxygen position. The pressure lever shall not stop between the normal and emergency position.

## MIL-PRF-83178C

4.6.32 Corrosion. The regulator, with the ports plugged, shall be subjected to the salt fog test specified in ASTM-B117 for 50 hours. There shall be no evidence of corrosion. The regulator shall then be subjected to the flow suction characteristics (see 4.6.3) and pressure breathing characteristics tests (see 4.6.5 and 6.5).

4.6.33 Cleanliness. All surfaces shall be free of visible particulates (50 microns and larger), free of visible fluorinated lubricants, and free of hydrocarbon contamination to a level not greater than 3 mg/ft<sup>2</sup> (see 6.6). Cleanliness of the surfaces shall be demonstrated by industrially accepted methods and these cleaning and verification methods shall be identified (see 6.2 and 6.6).

4.6.34 Reliability test. The reliability test shall use oxygen conforming to SAE-AS8010, and shall consist of simulated breathing cycles (see 6.8) at rate not exceeding 40 cpm while the regulator is subjected to vibration specified below. Thirty five percent of the cycles shall be with the diluter lever in the 100% oxygen position, 35% of the cycles shall be with the diluter lever the normal oxygen position, and 30% of the cycles shall be with the pressure lever in the emergency position. The peak delivery for 90% of the breathing cycles shall be from 0 to 30 LPM and back to 0 LPM. The other 10% of the breathing cycles shall have peak delivery from 0 to 70 LPM and back to 0 LPM. The vibration shall be at a double amplitude of 0.018 to 0.020 inch. The frequency of vibration shall vary from 300 to 3,000 cpm and back to 300 cpm at a constant rate. The regulator shall be mounted with the panel facing up. The regulator shall be subjected to the flow suction characteristics (see 4.6.3), oxygen ratio (see 4.6.4), flow indicator (see 4.6.15), and pressure breathing characteristics tests (see 4.6.5) at least once each 400,000 cycles. The regulator shall have a MCBF of not less than 700,000 cycles at 90% lower confidence limit (see 6.7).

4.6.35 Operating life span. The reliability test (see 4.6.34) shall be continued to determine the life span of the regulator. The regulator shall have a life span of not less than 2,700,000 cycles before the regulator can not be repaired and consistently fails to meet the specified MCBF.

4.6.36 Ozone resistance test. Samples of elastomer materials shall meet the test specified in ASTM-D1149. The test samples shall be elongated 20%, placed in an ozone free atmosphere for 24 hours and then subjected to an ozone environment. The temperature shall be 100 ±2°F, an ozone concentration of 120 ±1 parts per million by volume, and the air velocity across the sample shall be at least 2 feet per second. The material shall be exposed to these conditions for 60 minutes. The test slabs shall be examined under 10x magnification for evidence of damage such as blooming, checking, or cracking (see 6.5).

4.6.37 Electromagnetic interference. The regulator lighting shall be tested at the limit level give on figure 6 using the test method described in MIL-STD-461, Method CS101.

4.6.38 Tester compatibility. The regulator shall be tested as specified in TO 15X-1-1 using Tester, PBG Oxygen Regulator, Field (pneumatic) (see 6.8).

## MIL-PRF-83178C

## 5. PACKAGING

5.1 Packaging. For acquisition purposes, the packaging requirements shall be as specified in the contract or order (see 6.2). When packaging of materiel is to be performed by DoD or in-house contractor personnel, these personnel need to contact the responsible packaging activity to ascertain packaging requirements. Packaging requirements are maintained by the Inventory Control Point's packaging activities within the Military Service or Defense Agency, or within the military service's system commands. Packaging data retrieval is available from the managing Military Department's or Defense Agency's automated packaging files, CD-ROM products, or by contacting the responsible packaging activity.

## 6. NOTES

(This section contains information of a general or explanatory nature that may be helpful, but is not mandatory.)

6.1 Intended use. The regulator covered by this specification is intended to be used in aircraft for short periods of time at altitudes up to 50,000 feet and for continuous use at altitudes up to 43,000 feet. The regulator should permit servicing of the aircraft oxygen system with the oxygen supply lever in the on position.

6.2 Acquisition requirements. Acquisition documents should specify the following:

- a. Title, number, and date of this specification.
- b. PIN number (see 1.2).
- c. Item identification (see 3.7 items a, d, and e).
- d. Supply voltage for panel lighting (see 4.6.16).
- e. The requirements for the vendor to identify proposed cleaning and verification methods (see 4.6.33).
- f. Packaging requirements (see 5.1).
- g. Data required.

6.3 Qualification. With respect to products requiring qualification, awards will be made only for products which are, at the time of award of contract, qualified for inclusion in QPD whether or not such products have actually been listed by that date. The attention of the contractors is called to these requirements, and manufacturers are urged to arrange to have the products that they propose to offer to the Federal Government tested for qualification in order that they may be eligible to be awarded contracts or orders for the products covered by this specification. Information pertaining to qualification of products may be obtained from OC-ALC/ENSDDA, 3001 Staff Drive, Tinker AFB, OK 73145 or via email at [af71@tinker.af.mil](mailto:af71@tinker.af.mil).

6.4 Inspection levels. Previous levels were S-1 in accordance with ANSI/ASQ Z1.4 for low temperature operation, maximum inlet pressure, altitude cycling, relief valve cycling, low temperature exposures, and high temperature exposure with an acceptance number 0 and reject number one. Sampling and inspection levels were S-2 for overload, supply valve cycling, toggle operating forces, reliability with an acceptance number 0 and reject number one.

## MIL-PRF-83178C

6.5 Materials. Material certification has been used to demonstrate compliance with material requirements.

6.6 Cleaning. See MIL-STD-1330 and MIL-STD-1359 for guidance on proven cleaning methods and verifications. Visible inspections are typically conducted using white light and ultraviolet light to detect particulates and some types of hydrocarbons. The non-volatile residue (NVR) test in MIL-STD-1359 may be used to baseline the hydrocarbon verification at an acceptable contamination level however, other cleaning and verification methods that do not contain class I and II ODC solvents should be used for production.

6.7 Reliability level. A MCBF of 700,000 cycles with 90% confidence limit is equivalent to a minimum acceptable MCBF of 466,667 cycles and a reliability of 0.9871 for a 10-hour, 9,000 cycle mission. Previous acquisitions referenced MIL-STD-781 and MIL-STD-785 when addressing regulator reliability.

6.8 Definitions.

a. Breathing cycle. A breathing cycle consists of a flow from 0 to a peak delivery rate, and back to 0 LPM at a rate of 10 cpm.

b. Flow suction characteristics. Flow suction is a physiological term to denote regulator demand operations where activation vacuum is created by human inhalation.

c. Health hazards. Materials such as cadmium, lead, and polyvinyl chloride are susceptible to outgasing in the pure oxygen and at elevated temperatures. Outgasing by these and many other materials when used in oxygen equipment are potential health hazards.

d. Operating life span. Operating life span is the period of time during which it is economical to repair the equipment and return it to the original operating condition.

e. PBG tester. The PBG tester is an automated portable field tester used to verify regulator demand and pressure performance, altitude performance, and test ports.

f. Pressure breathing characteristics. Pressure breathing denotes regulator pressure operations where the physiological needs for 100% oxygen exceed delivery at ambient pressure, and must be delivered at positive pressure.

g. Zero feet pressure altitude. The reference to a zero pressure altitude is intended to be ambient ground level of the manufacturing and test facilities and is not considered an absolute value. The pressure altitude of ground level will vary due to facility locations and atmospheric conditions.

6.9 Supply lever actuation. The ability to balance or physically prop the supply lever on the apex of the cam between the on and off position does not constitute a failure. The lever should return to either the on or off position once released or moved of the apex.

6.10 Test port requirements. The regulator should permit ground testing of dilution, flow suction, and pressure breathing performance at any altitude up to 50,000 feet by the portable tester. The test port requirements allow compatibility with PBG tester. The ability to apply a vacuum to the pressure breathing test port without applying a vacuum to the main body of the regulator prevents damage to the main regulator components. Test ports are designed such that when vacuum simulating altitude is applied to the pressure breathing port, the regulator will deliver pressure at the

## MIL-PRF-83178C

outlet. When a pressure measuring device is attached at the air inlet test port , it should be possible to check the altitude the air mixing valve closes and the operation of the air inlet test port check valve.

6.11 Flow suction design. The flow suction characteristics requirements provide additional design information, and are not verified at all ranges. Due to changes in air density and pressure associated with higher altitudes, meeting the flow suction characteristics requirements at ground level ensures the altitude requirements are obtainable. Outlet flow levels greater than 86 LPM may damage the regulator if performed at ground level and should be avoided.

6.12 Elastomers. Silicone has been the preferred material for elastomer components. These silicone components have the required ozone-resistances and exhibit the desired longevity and shelf life.

6.13 Added oxygen. The added oxygen ratio is a measure of the quantity of pure oxygen the regulator adds from the onboard oxygen system to the regulator outlet. With the diluter lever in the normal position, the pure oxygen is diluted with ambient air, and this amount of added oxygen is varied with altitude. With the diluter lever in the 100% position, the regulator adds from 98 to 100% pure oxygen at all altitudes. The altitude is considered to be the cabin altitude to which the regulator and crew are exposed.

6.14 Subject term (key word) listing.

Elastomers  
Flow indicator  
Leakage  
Panel lighting  
Gage  
Lever  
Outlet leakage

6.15 Changes from previous issue. Marginal notations are not used in this revision to identify changes with respect to the previous issue due to the extent of the changes.

## MIL-PRF-83178C

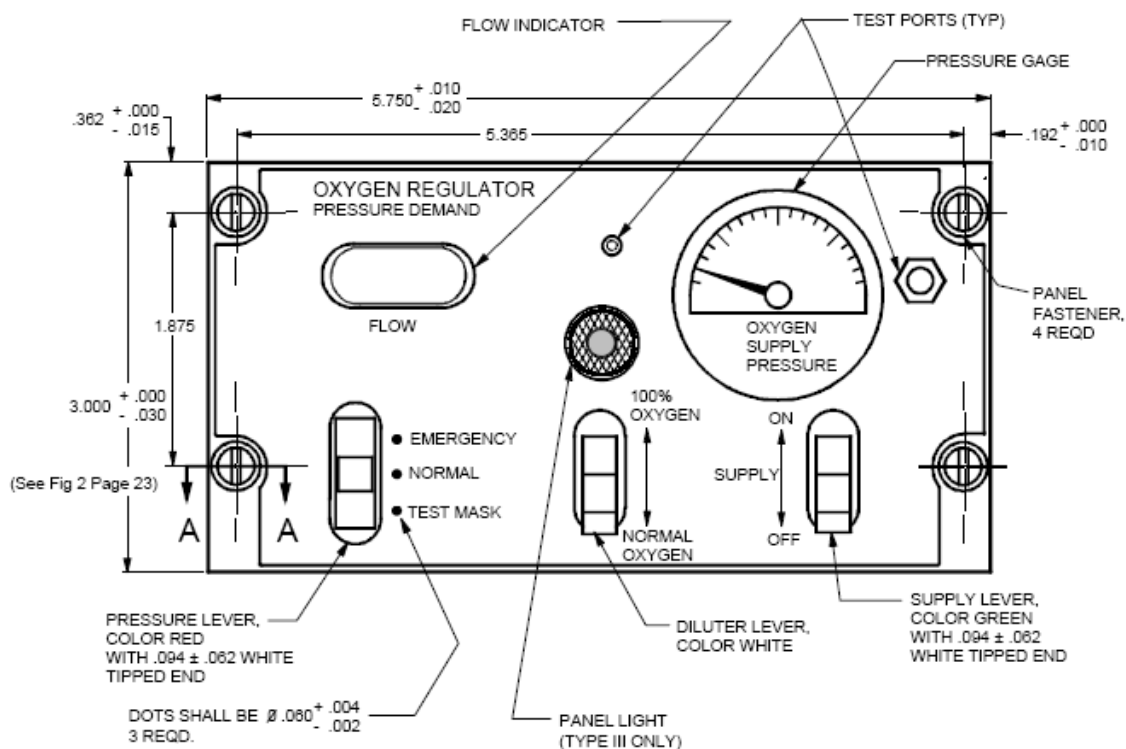

Superseding PIN or P/N	Government Designation	MIL-P-7788 Lighting Requirements			Superseded PIN or P/N
		Type	Class	Background	
M83178-1	CRU-73A	III	1-W	Black	MS27599-1
M23178-2	CRU-73A	IV or V	1-NVIS Green A	Black	
M83178-3	CRU-73A	IV	1-BW	Black	MS27599-2

Note: For Type III only, panel light sockets shall be compatible with MS90335-9, MS25010A12A, or MS25453-3. For all types, lamps shall conform to MIL-DTL-6363/8.

## Notes:

1. Unless otherwise specified, dimensions are in inches.
2. Unless otherwise specified, decimals tolerances are  $\pm .005$ .
3. Panel lettering size and location is for reference only. Lettering shall identify the regulator type, function and position of each lever, the gage, and flow indicator.
4. Test port location is for reference only.
5. For Type III panels, the light location is for reference only.
6. Drawing is not to scale.

FIGURE 1. Regulator panel.

MIL-PRF-83178C

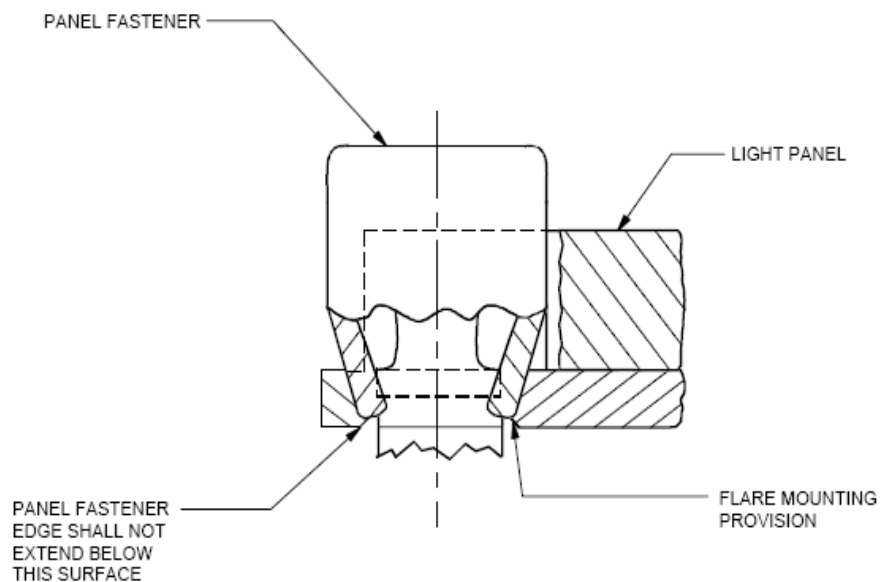

SECTION A-A

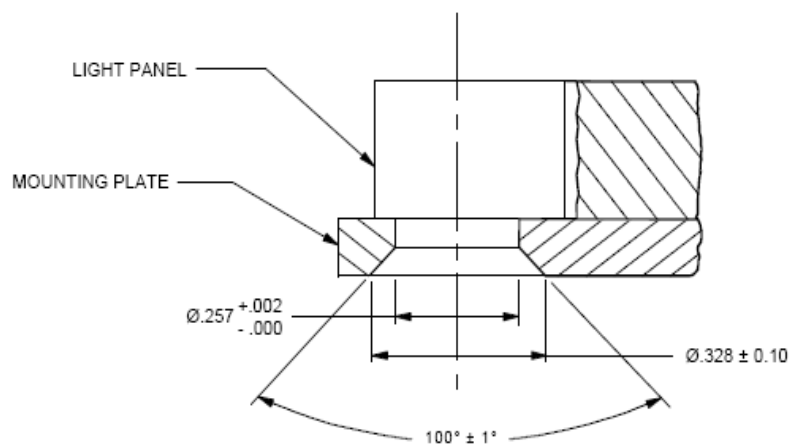

Notes:

1. Unless otherwise specified, dimensions in inches.
2. Drawing is not to scale.

FIGURE 2. Panel fastener

## MIL-PRF-83178C

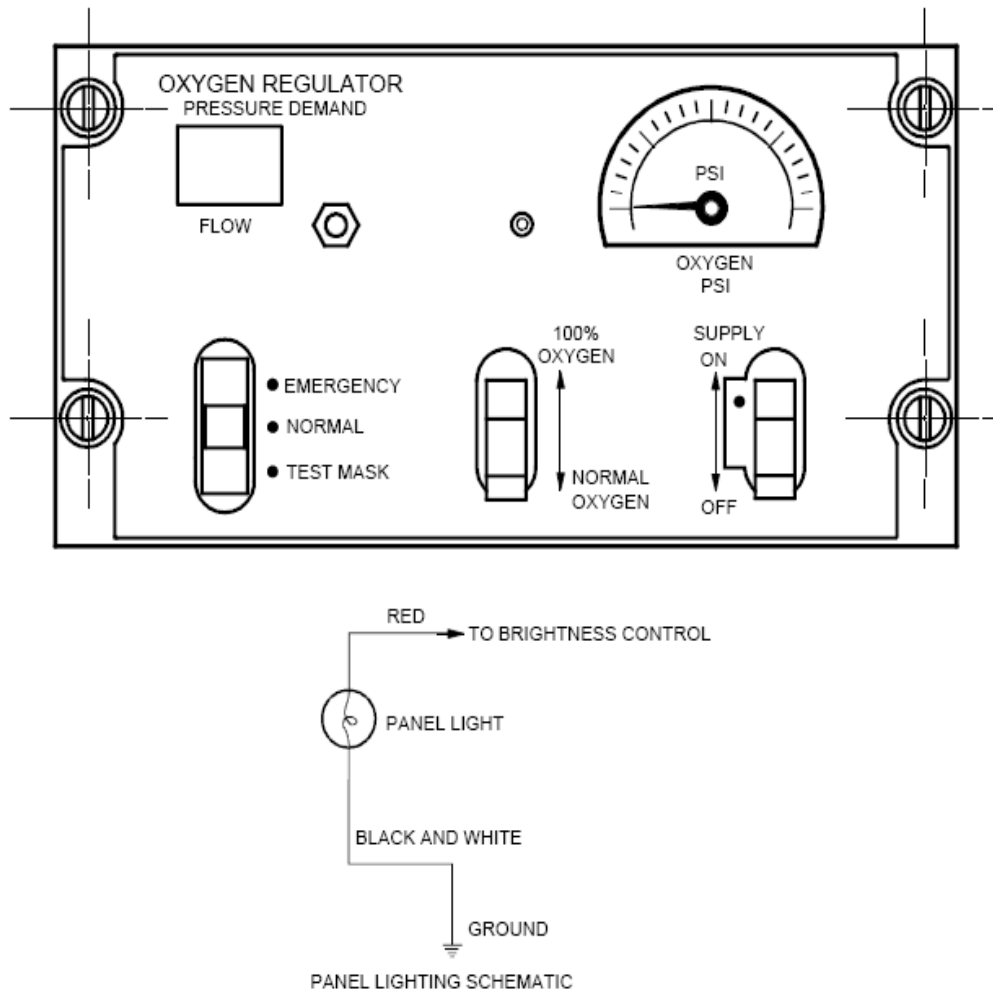

## Notes:

1. Panel lettering size and location is for reference only. Lettering shall identify the regulator type, function and position of each lever, the gage, and the flow indicator.
2. Test port location is for reference only.
3. For detailed information see figure 1.
4. Drawing is not to scale.

FIGURE 3. Regulator panel (alternate configuration)



## MIL-PRF-83178C

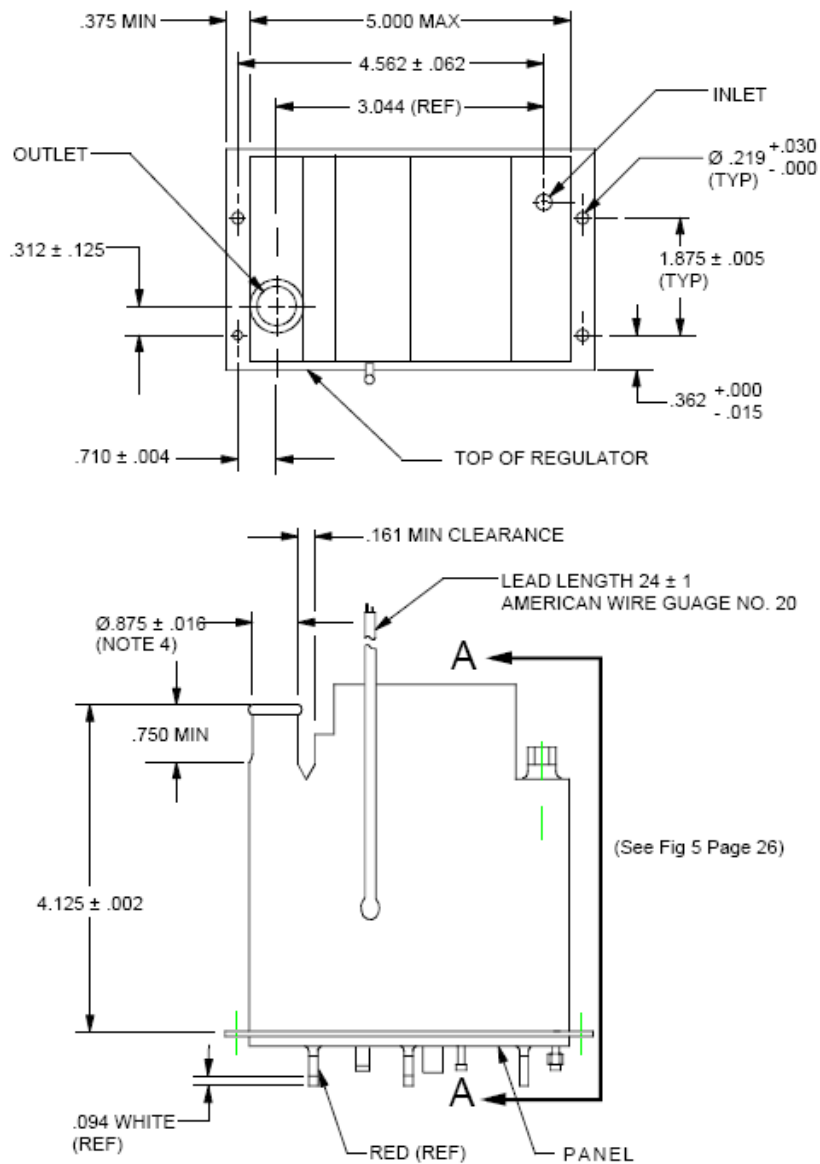

## Notes:

1. Unless otherwise specified, dimensions in inches.
2. Tolerances: decimals ±.005.
3. The -3 version shall be supplied with electrical connector MS27473TIOB5P and strain relief M85049/46W10.
4. Outlet diameter does not include the lip which is a slippage restriction for clamping.
5. Drawing is not to scale.

FIGURE 4. Regulator dimensions

## MIL-PRF-83178C

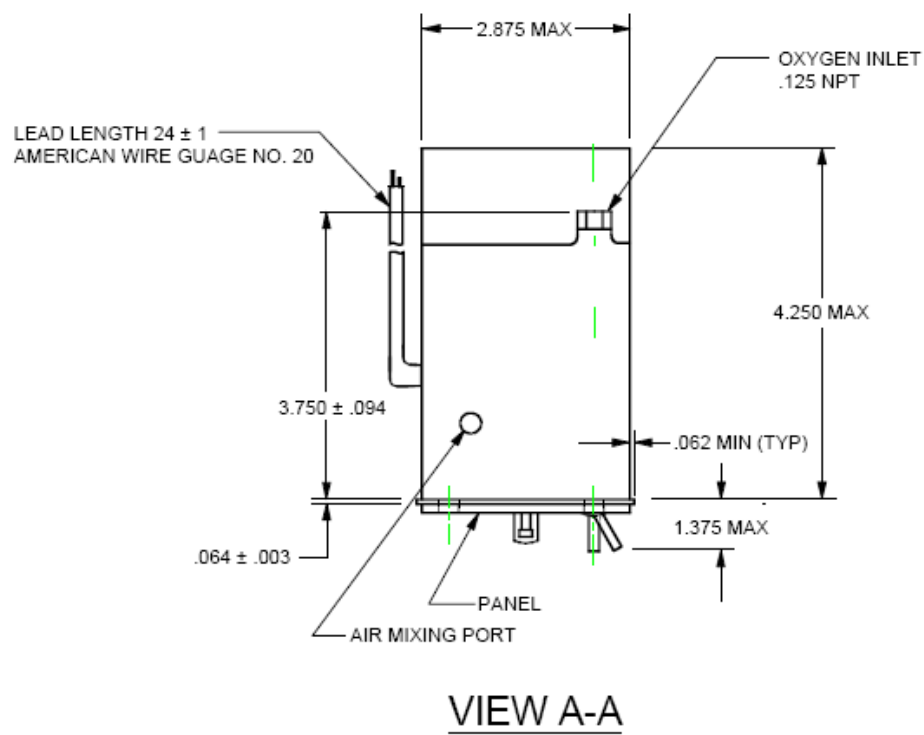

## Notes:

1. Unless otherwise specified, dimensions in inches.
2. Tolerances as indicated.
3. The -3 version shall be supplied with electrical connector MS27473TIOB5P and strain relief M85049/46W10.
4. Drawing is not to scale.

FIGURE 4. Regulator dimensions - Continued

## MIL-PRF-83178C

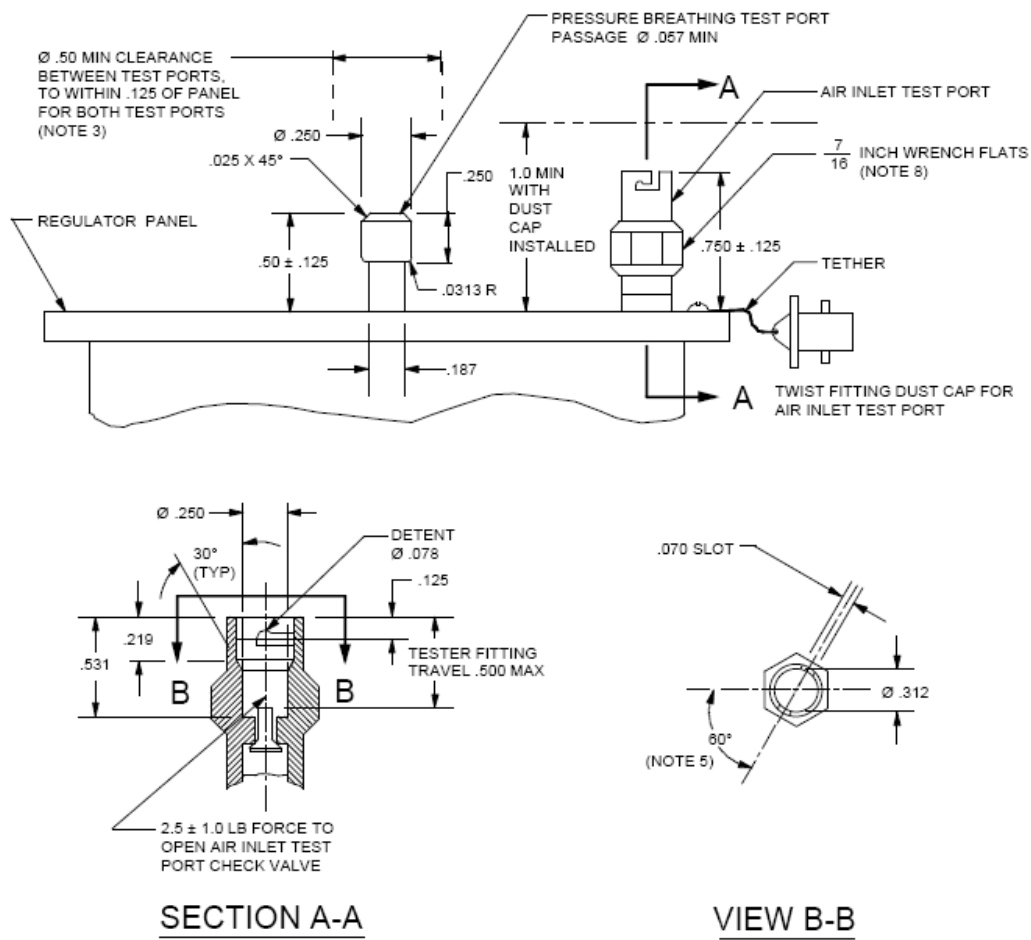

## Notes:

1. Unless otherwise specified, dimensions in inches.
2. Tolerances: decimals  $\pm .005$ , angles  $\pm 2$  degrees.
3. Test port clearances are required to accommodate the PBG tester connectors.
4. Test port location optional.
5. A  $60^\circ$  rotation required to engage detent.
6. Fittings shall require a torque greater than 5 in-lb to loosen.
7. Drawing is not scale.
8. Wrench flat size is for reference only.

FIGURE 5. Test ports

MIL-PRF-83178C

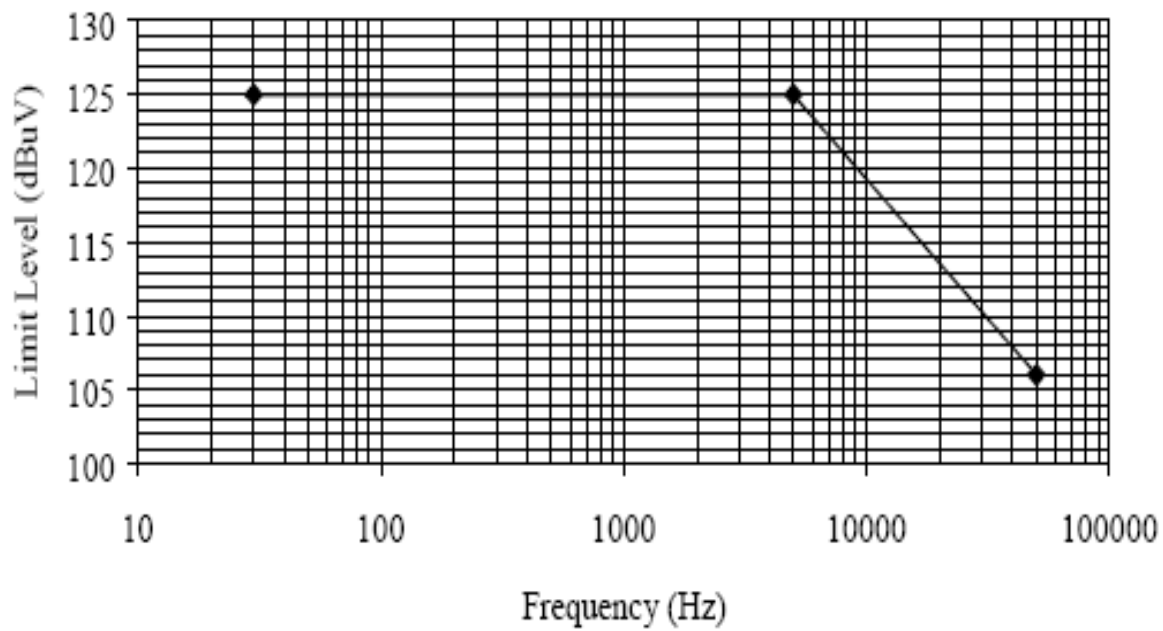

FIGURE 6. CS101 limit

MIL-PRF-83178C

Custodians:  
Air Force - 71

Preparing Activity:  
Air Force – 71

(Project 1660-2009-002)

Review Activities:  
Air Force – 11, 99

NOTE: The activities listed above were interested in this document as of the date of this document. Since organizations and responsibilities can change, you should verify the currency of the information above using the ASSIST Online database at <http://assist.daps.dla.mil/>.