

NOT MEASUREMENT
SENSITIVE

MIL-PRF-81705D
w/AMENDMENT 1
14 July 2004
SUPERSEDING
MIL-PRF-81705D
3 September 1998

PERFORMANCE SPECIFICATION

BARRIER MATERIALS, FLEXIBLE, ELECTROSTATIC PROTECTIVE, HEAT-SEALABLE

This specification is approved for use by all Departments and Agencies of the Department of Defense.

1. SCOPE

1.1 Scope. This specification establishes the requirements for heat-sealable, electrostatic protective, flexible barrier materials used for the military packaging of microcircuits, sensitive semiconductor devices, sensitive resistors, and associated higher assemblies. In addition, the type I materials provide for watervaporproof protection and attenuation of electromagnetic radiation (see 6.1).

1.2 Classification. The barrier materials are furnished in the following types and classes.

Type I - Watervaporproof, electrostatic protective, electrostatic and electromagnetic shielding.

Class 1 - Unlimited use.

Class 2 - For use on automated bag making machines only.

Type II - Transparent, waterproof, electrostatic protective, static dissipative.

Class 1 - Unlimited use.

Class 2 - For use on automated bag making machines only.

Beneficial comments (recommendations, additions, deletions) and any pertinent data which may be of use in improving this document should be addressed to: Commander, Naval Air Warfare Center Aircraft Division, Code 414100B120-3, Highway 547, Lakehurst, NJ 08733-5100, by using the Standardization Document Improvement Proposal (DD Form 1426) appearing at the end of this document or by letter.

AMSC N/A

FSC 8135

DISTRIBUTION STATEMENT A. Approved for public release; distribution is unlimited.

MIL-PRF-81705D

Type III - Transparent, waterproof, electrostatic protective, electrostatic shielding.

Class 1 - Unlimited use.

Class 2 - For use on automated bag making machines only.

2. APPLICABLE DOCUMENTS

2.1 General. The documents listed in this section are specified in sections 3 and 4 of this specification. This section does not include documents cited in other sections of this specification or recommended for additional information or as examples. While every effort has been made to ensure the completeness of this list, document users are cautioned that they must meet all specified requirements documents cited in sections 3 and 4 of this specification, whether or not they are listed.

2.2 Government documents.

2.2.1 Specifications, standards, and handbooks. The following specifications, standards, and handbooks form a part of this document to the extent specified herein. Unless otherwise specified, the issues of these documents are those listed in the issue of the Department of Defense Index of Specifications and Standards (DoDISS) and supplement thereto, cited in the solicitation (see 6.2).

SPECIFICATIONS

FEDERAL

- QQ-S-698 - Steel, Sheet and Strip, Low Carbon.
- QQ-A-250/4 - Aluminum Alloy 2024, Plate and Sheet.

STANDARDS

- FED-STD-101 - Test Procedures for Packaging Materials.

(Unless otherwise indicated, copies of the above specifications, standards, and handbooks are available from the Standardization Document Order Desk, 700 Robbins Avenue, Building 4D, Philadelphia, PA 19111-5094.)

2.3 Non-Government publications. The following documents form a part of this document to the extent specified herein. Unless otherwise specified, the issues of the documents which are DoD adopted are those listed in the issue of the DoDISS cited in the solicitation. Unless otherwise specified, the issues of documents not listed in the DoDISS are the issues of the documents cited in the solicitation (see 6.2).

MIL-PRF-81705D

AMERICAN NATIONAL STANDARDS INSTITUTE (ANSI)

- J-STD-006 - Electronic Grade Solder Alloys and Fluxed and Non-Fluxed. Solid Solders for Electronic Soldering Applications Requirements.

(Application for copies should be addressed to American National Standards Institute, 11 West 42nd Street, New York, NY 10036.)

AMERICAN SOCIETY FOR QUALITY CONTROL (ASQC)

- ASQC-Z1.4 - Procedures, Sampling and Tables for Inspection by Attributes. (DoD adopted)

(Application for copies should be addressed to the American Society for Quality Control, P.O. Box 3005, 611 East Wisconsin Avenue, Milwaukee, WI 53201-4606.)

AMERICAN SOCIETY FOR TESTING AND MATERIALS (ASTM)

- ASTM-B451 - Copper Foil, Strip, and Sheet for Printed Circuits. and Carrier Tapes, Specification for.
ASTM-D257 - Resistance DC or Conductance of Insulating Materials (DoD adopted)
ASTM-D471 - Rubber Property – Effect of Liquids. (DoD adopted)
ASTM-F15 - Iron-Nickel-Cobalt Sealing Alloy, Specification for.

(Application for copies should be addressed to the American Society for Testing and Materials, 100 Barr Harbor Dr., West Conshohocken, PA 19428-2959.)

ELECTRONIC INDUSTRIES ASSOCIATION (EIA)

- EIA-541 - Packaging Material Standards for ESD Sensitive Items.

(Application for copies should be addressed to the Electronic Industries Association, Engineering Department, 2500 Wilson Blvd., Arlington, VA 22201-3834.)

2.4 Order of precedence. In the event of a conflict between the text of this document and the references cited herein, the text of this document takes precedence. Nothing in this document, however, supersedes applicable laws and regulations unless a specific exemption has been obtained.

MIL-PRF-81705D

3. REQUIREMENTS

3.1 Qualification. The barrier materials furnished under this specification shall be products that are authorized by the qualifying activity for listing on the applicable qualified products list before contract award (see 4.2 and 6.4).

3.2 Material. Barrier materials shall be made from such materials and by such processes as to ensure compliance with the performance requirements of this specification.

3.3 Construction. Barrier materials shall be constructed of one or more plies in any manner which ensures compliance with the performance requirements of this specification.

3.3.1 Type I. Butting of type I component materials or the finished product is not permitted except in the direction perpendicular to the rolling direction. When a butt weld is made on the finished product or any ply thereof, the areas shall be externally flagged with color markers to prevent use of that portion of the roll.

3.3.2 Type II. Type II barrier material shall be transparent, clear, or tinted any color. The appearance shall be the same throughout the material. The materials shall have no talc or other powdered substances applied to the surfaces.

3.3.3 Type III. Type III barrier material shall be transparent, clear, or tinted any color. The appearance shall be the same throughout the material. Butting of component materials or the finished product is not permitted except in the direction perpendicular to the rolling direction. When a butt weld is made on the finished product or any ply thereof, the areas shall be externally flagged with colored markers to prevent use of that portion of the roll.

3.3.4 Splices. A roll shall not contain more than 3 splices (4 pieces) and each piece shall be not less than 45 yards in length. Splices within rolls shall be even the entire width of the roll material and shall not come apart during unwinding of the roll. Rolls containing splices shall be flagged at both ends of each splice with colored markers to indicate splices within the roll. Barrier material in flat cut sheets shall not contain splices (see 4.3.2.2).

3.4 Form. The barrier material shall be furnished in rolls or flat cut sheets as specified in the contract or delivery order (see 6.2). Rolls of type II and type III material shall be furnished in the form of sheeting or lay flat tubing as specified in the contract or purchase order (see 6.2).

3.4.1 Rolls. Unless otherwise specified (see 6.2), the width of roll material shall be 36 inches, with a tolerance of plus or minus 1/4 inch. The average length of roll material shall be not less than 200 yards. The length of any individual roll shall be not less than 195 yards. The roll material shall be uniformly wound on nonreturnable cores. The core's inside diameter shall be not less than 3 inches, with a tolerance of plus 1/8 inch. The length of the core shall be equal

MIL-PRF-81705D

to the width of the roll material, with a tolerance of plus 1/8 inch. The core shall be rigid to prevent distortion of the roll during use and shipment conditions. Each roll shall be restrained to prevent unwinding (see 4.3.2.2 and 4.3.2.3).

3.4.2 Sheets. When flat cut sheets are specified, the length and width shall be as specified by the acquiring activity. If the length and width tolerances for cut sheets are not specified the tolerance for each shall be plus 1/4 inch or minus 1/8 inch (see 4.3.2.3). Flat cut sheets shall be evenly stacked (see 4.3.2.2).

3.5 Sealing. The material shall exhibit no delamination of the sealed area when sealed according to the manufacturer's recommended conditions (see 4.5). Each roll or package (flat cuts) of barrier material shall include a tag secured to the core of rolls, or sheet inserted in the package of sheets with the sealing instructions for impulse seals and for heat-sealing on rotary, band and jaw type sealing equipment. The tag or sheet shall be visible upon opening the unit package (see 4.3.2.2).

3.6 Identification of material. The material shall have two groups of markings in block form and in machine direction. Group A marking shall state the specification number, type, class, manufacturer's name, manufacturer's designation, month and year of manufacture, and lot number. The letters and figures shall be clear, legible, and shall be not less than 1/8 inch high. Group B markings shall identify the protective qualities of the materials as follows: For type I – EMI/STATIC SHIELD, for type II – STATIC DISSIPATIVE, and for type III – STATIC SHIELD. These letters shall be not less than 1/2 inch high. The two groups of markings on all three types of material shall be either printed using a water-resistant ink or embossed and shall be visible if the material is fabricated into a bag or pouch. The two groups of markings shall be printed or embossed sequentially, complete, and continuous lengthwise with a space of one inch between groups. A complete group of markings shall appear once in each six inches of width of the roll and flat cut. An example of the identification is as follows (see 4.3.2.1 and 4.3.2.3):

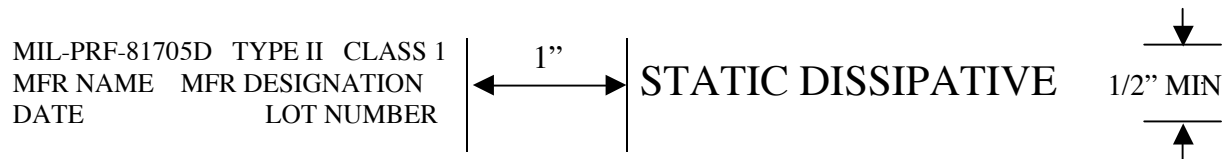

3.7 Performance requirements. The performance of the barrier materials shall conform to the requirements specified in table I, when tested in accordance with 4.6.

3.8 Workmanship. Barrier material surfaces shall be free from any foreign matter. Barrier material shall be free from holes, tears, cuts, sharp creases, wrinkles, or other imperfections. The barrier material shall be cut and trimmed of any selvage (see 4.3.2.1).

MIL-PRF-81705D

TABLE I. Performance requirements.

Characteristics	Applicable to types	Requirements	Test Paragraph Reference
Seam Strength 1. As received material sealed & tested: a. At room temperature (separation-inches) b. At 100 °F and at 160 °F (separation-inches) 2. Sealed before aging at 160 °F for 12 days and tested: a. At room temperature (separation-inches) b. At 100 °F and at 160 °F (separation-inches) 3. Sealed after aging at 160 °F for 12 days and tested: a. At room temperature (separation-inches) b. At 100 °F and at 160 °F (separation-inches)	I, II, III	No separation No separation No separation No separation No separation No separation	4.6.2
Seam Fabrication	I, II, III	No leakage at double seam junction	4.6.3
Water vapor transmission rate (WVTR) 1. After room temperature flexing: a. As received (gms/100 sq. in./24 hrs.) b. Aged (gms/100 sq. in./24 hrs.) (See 4.6.4) 2. WVTR after low temperature flexing: As received (gms/100 sq. in./24 hrs.)	I	0.02 (max) 0.02 (max) 0.03 (max)	4.6.1
Blocking resistance	I, II, III	No blocking, delamination, or rupture	4.6.1
Resistance to curl	I, II, III (Class 1)	No curl in excess of 5% or curl back upon itself	4.6.1
Contact corrosivity	I, II, III	No corrosion, etching, or pitting	4.6.1

MIL-PRF-81705D

TABLE I. Performance requirements – Continued.

Characteristics	Applicable to types	Requirements	Test Paragraph Reference
Aging resistance	I, II, III (laminated only)	No delamination or rupture as specified in 4.6.4.1	4.6.4
Thickness	I II, III	0.015 inch (max) 0.006 inch (max)	4.6.1
Water resistance of markings	I, II, III (printed only)	Markings shall be clear and legible	4.6.1
Marking abrasion resistance	I, II, III	No smearing, blurring, or loss of legibility	4.6.7
Water resistance	I, II, III (laminated only)	No delamination	4.6.1
Transparency	II, III	Lettering shall be readable 3 inches behind material	4.6.1
Oil resistance (delamination)	I, II, III (laminated only)	No leakage, swelling, delamination, or embrittlement	4.6.1
Waterproofness	II, III	No dye penetration	4.6.5
Puncture resistance	I II, III	10 lbs (min) 6.0 lbs (min)	4.6.1
Static decay	I, II, III	The decay shall be not greater than 2.0 seconds	4.6.1
Electromagnetic interference (EMI) attenuation	I III	25 db (min) 10 db (min)	4.6.6
Surface resistivity	I, II, III	Inner: Greater than or equal to 1×10^5 ohms/sq but less than 1×10^{12} ohms/sq. Outer: less than 1×10^{12} ohms/sq	4.6.8
Electrostatic shielding	I, III	30 volts peak (max)	4.6.9

MIL-PRF-81705D

4. VERIFICATION

4.1 Classification of inspections. The inspection requirements specified herein are classified as follows:

- a. Qualification inspection (see 4.2).
- b. Conformance inspection (see 4.3).

4.2 Qualification inspection. The qualification inspection shall consist of all tests and examinations of this specification.

4.3 Conformance inspection. Conformance inspections consist of the required tests listed in table II and the examinations listed in tables III through V.

TABLE II. Conformance tests.

Characteristics	Paragraph Reference
Seam strength	--
As received	4.6.2.2
Sealed after aging	4.6.2.4
Water vapor transmission rate (type I only)	4.6.1
As received	4.6.1
After aging	4.6.1
Oil resistance (laminated only)	4.6.1
Static decay (type II only)	4.6.1
Surface resistivity (interior and exterior)	4.6.8
Electrostatic shielding (type I and type III)	4.6.9
Puncture resistance	4.6.1

4.3.1 Sampling for conformance inspection. Unless otherwise specified, sampling for inspection shall be performed in accordance with the provisions set forth in ASQC-Z1.4.

4.3.2 Examination of the end item. For the purpose of determining the sample size in accordance with ASQC-Z1.4, the lot size shall be expressed in units of rolls or packages of sheets, as applicable, for examinations under 4.3.2.1 through 4.3.2.3.

4.3.2.1 Examination of the end item for defects in appearance, construction, and workmanship. For examination of defects within rolls, the sample unit of product shall be two yards, the full width of the roll. For examination of sheets, the sample unit shall be two sheets randomly selected from a package. No more than five sample units, randomly selected, shall be

MIL-PRF-81705D

drawn from any one roll or package of sheets, as applicable. Both sides of the material shall be examined.

TABLE III. Examination of end item for defects in appearance, construction, and workmanship.

EXAMINATION	DEFECT
Form	Not roll or flat cut, as specified. Incorrect type or class of material.
Appearance	Surfaces not clean; presence of any foreign matter, dirt, sand, grit, or oil spots. (Note: Defects do not apply to outer convolution of roll.)
Workmanship	Blister, crack, cut, hole, tear, sharp crease, chafed spot or scuff mark. (Note: Defects do not apply to outer convolution of roll.) Evidence of delamination or embrittlement. Edges not clean cut; ragged, crushed, or uneven.
Construction	Not uniform; layer or section missing, selvage present, fish eyes.
Identification markings	Illegible, incorrect, incomplete, or omitted. Not continuous lengthwise. Not printed or embossed.

4.3.2.2 Examination of the end item for defects in general construction. The sample unit for this examination shall be one roll or one package of sheets, as applicable.

TABLE IV. Examination of end item for defects in general construction.

EXAMINATION	DEFECT
Assembly of sheets	Not evenly and uniformly stacked; sheet containing manufacturer's sealing conditions not visible upon opening. Adjacent sheets stick together to the extent that separation causes tearing or injury to any surface. Splice within sheet.
Assembly of roll	Not restrained to prevent unwinding. Material not wound uniformly on roll causing soft or uneven edges, or telescoping of roll. Material not wound on rigid core, core broken, collapsed, crushed, mutilated.

MIL-PRF-81705D

TABLE IV. Examination of end item for defects in general construction - Continued.

EXAMINATION	DEFECT
Unwinding of roll (check both sides)	When unwound, material sticks together to the extent that unrolling causes tearing or injury to any surface. Material wound unevenly causing wrinkles, sharp creases, or folds within roll. Roll not continuous; more than 3 splices (4 pieces) in roll or more than 1 splice in any 50 consecutive yards. Splice(s) not evenly made; does not cover entire width of material; comes apart during unwinding of roll.
Sealing instructions	Manufacturer's instructions for sealing conditions of the material not securely attached to core of roll.

4.3.2.3 Examination of the end item for dimensional defects. The sample unit for this examination shall be one roll or one package of sheets, as applicable.

TABLE V. Examination of the end item for dimensional defects.

EXAMINATION	DEFECT
Sheets	Length or width varies by more than plus 1/4 inch or minus 1/8 inch from dimensions specified.
Rolls: Width Length Core	Varies by more than plus or minus 1/4 inch from width specified. Length of any individual roll is less than 195 yards, or the average length of roll material is less than 200 yards. Length of core is less than width of roll material, or greater by more than plus 1/8 inch. Inside diameter less than 3 inches or greater than 3 1/8 inches.
Identification markings	Lettering is less than 1/8 inch in height for Group A markings. More than 1 inch distance between lengthwise group of markings. Complete group of markings does not appear once in six inches of width. Lettering is less than 1/2 inch in height for Group B markings.

4.4 Test conditions. Unless otherwise specified in the detailed test methods herein, the physical tests contained in this specification shall be made with an atmosphere having a relative

MIL-PRF-81705D

humidity of 50 ± 5 percent and a temperature ranging from 70 to 76 °F. Material shall be considered in equilibrium after exposure to the above conditions for a minimum of 24 hours.

4.5 Sealing instructions for qualification and conformance testing.

a. All seals for test purposes shall be not less than 1/2-inch wide and shall be effected on a jaw-type heat-sealer or equivalent as approved by the qualifying activity utilizing the sealing conditions recommended by the manufacturer. The upper sealing conditions for production line sealing operations with respect to commercially available sealing equipment and commercially practical fabrication time are a temperature setting of 525 °F, a 3-second dwell time, and a pressure of 60 pounds per square inch (see 6.3).

b. Impulse seals for test purposes shall be a minimum of 1/16-inch wide and shall be effected on impulse sealers, or equivalent as approved by the qualifying activity. The upper sealing limits on the sealer shall effect a seal and not cause thinning at the inside edges of the seal.

c. In the securing of the three 1-inch seam strength specimens from their respective samples (see 4.6.2.2.1), specimens shall not be removed:

- (1) From points in the sealed sample where seal overlapping has occurred.
- (2) From points in the sealed sample that were within 1-inch of either end of the sealer jaw during the sealing operation.

4.6 Verification of performance requirements.

4.6.1 Test methods. Unless otherwise specified, the tests in table VI shall be conducted in accordance with the identified methods of FED-STD-101.

MIL-PRF-81705D

TABLE VI. Test methods.

Tests	Applicable to Types	FED-STD-101 Test Method No.	Special Requirement or Exception Note
Water vapor transmission rate After room temperature flexing (as received and aged)	I	2017	<u>1/</u>
Transmission rate procedure	I	3030 procedure A(1)	--
Water vapor transmission rate After low temperature flexing	I	2017	<u>2/</u>
Transmission rate procedure	I	3030 procedure A(1)	--
Puncture resistance	I, II, III	2065	<u>3/</u>
Blocking resistance	I, II, III	3003 procedure D	--
Resistance to curl	I, II, III (Class 1 only)	2015	<u>4/</u>
Contact corrosivity	I, II, III	3005	<u>5/</u>
Oil resistance (delamination)	I, II, III (laminated only)	3015	<u>6/</u>
Water resistance	I, II, III (laminated only)	3028 procedure F	<u>7/</u>
Water resistance of marking	I, II, III (printed only)	3027	<u>8/</u>
Static decay	I, II, III	4046	<u>9/</u>
Transparency	II, III	4034	<u>10/</u>
Thickness	I, II, III	1003	<u>10/</u>

- 1/ Full stroke shall be used on both as received and aged specimens.
- 2/ Conduct tests as specified in FED-STD-101, Method 2017 except that only 'as received' specimens shall be tested. Prior to flexing, test specimens shall be conditioned for at least 30 minutes at -20 ± 2 °F and the flexing operation shall be conducted at -20 ± 2 °F.
- 3/ Test shall be run on five specimens. Material under test shall have heat-sealable face in contact with the probe. The average value for the five specimens tested shall meet the requirements as specified in table I. Elongation test data is not required.

MIL-PRF-81705D

- 4/ Three specimens shall be tested. Specimens shall not be suspended, but shall be placed on a horizontal surface.
- 5/ The following test surfaces shall be used for testing and shall be exposed for 72 hours:
 - a. QQ-S-698, low carbon steel, condition 5.
 - b. QQ-A-250/4, aluminum alloy, 2024 bare.
 - c. Copper, as specified in ASTM-B451, nominal thickness 0.014 inches.
 - d. Silver plated copper foil (foil same as in c), plating thickness 100-200 microinches.
 - e. SN63 tin-lead eutectic solder copper foil (foil same as in c), coating thickness 200-500 microinches, J-STD-006.
 - f. Stainless steel, Unified Numbering System UNS31400.
 - g. Kovar as specified in ASTM-F15.
- 6/ Oil conforming to ASTM oil number 3, as specified in ASTM-D471, and a di-2-ethylhexyl sebacate synthetic oil shall both be used.
- 7/ Use distilled water. Delamination shall be measured as ply separation at any one given point extending more than 1/2 inch from the edge, with an edge length separation greater than one inch.
- 8/ Three specimens shall be tested, each one containing a complete set of markings.
- 9/ The average value for the three specimens tested for each exposure condition (as received, after aging, and after shower exposure) shall meet the requirement specified in table I. The decay time to measure is the time it takes to dissipate 99 percent of the initial 5000 volt charge (both positive and negative). Testing shall be performed in an atmosphere maintained at 73 ± 5 °F and 12 ± 3 percent relative humidity.
- 10/ Three specimens shall be tested.

4.6.2 Seam strength.

4.6.2.1 Seam strength samples. Samples measuring 6 by 12 inches shall be selected from the test material as shown on figure 1. Samples shall be drawn in duplicate for type II and type III materials only. Heat-seal shall be applied to one set of samples, impulse seals shall be applied to the other set.

4.6.2.2 Seam strength “as received”.

4.6.2.2.1 Preparation of test specimen. The four specimens for this test shall be folded in half with the crease parallel to the long axis. The open or unfolded length shall be sealed. The sealed areas shall be indicated by a line drawn on the back of the specimen. The folded length shall be cut off 1/2 inch from the end. From each of the four sections, three adjacent 1-inch-wide specimens shall be cut perpendicular to the seam (see 4.5). One of the specimens from each section shall be used for test at room temperature, one from each section for test at 100 °F, and the remaining one from each section for test at 160 °F. After heat-sealing and prior to the application of the specified weights, the specimens in all cases shall be exposed for one hour to the test conditions specified in 4.4.

MIL-PRF-81705D

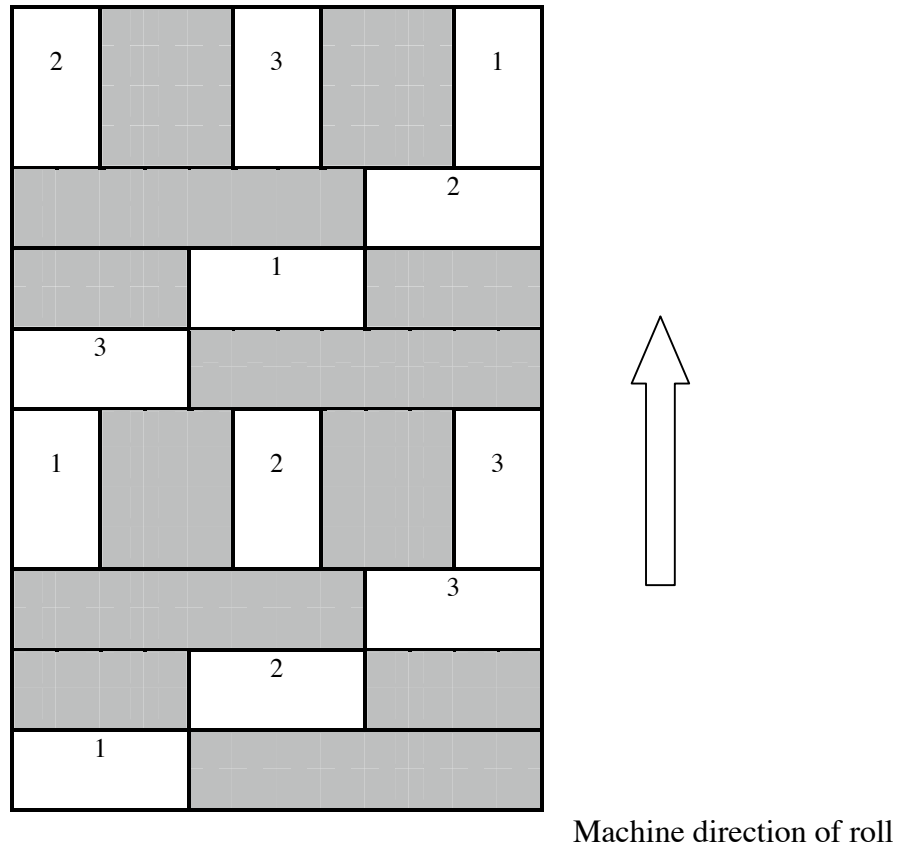
**KEY**

- 1 - 6 inch by 12 inch sample for "As Received" testing
- 2 - 6 inch by 12 inch sample for "Sealed before Aging" testing
- 3 - 6 inch by 12 inch sample for "Sealed after Aging" testing

FIGURE 1. Sampling method for seam strength test.

MIL-PRF-81705D

4.6.2.2.2 Test at room temperature. The four 1-inch-wide specimens selected for this test (see 4.6.2.2.1) shall be opened and one end of each specimen shall be clamped so that the other end of the specimen hangs freely. A 3 1/2 pound weight \pm 1/2 ounce shall then be carefully attached to the free end of the specimen so as not to impact load the seal. The weight shall be allowed to act for 5 minutes, whereupon the weight shall be removed and the specimen examined for separation of the heat-sealed faces. Any evidence of delamination of one ply away from the other in the heat-sealed area shall be cause for rejection. The evaluation shall be limited to the heat-sealed area specified in 4.6.2.2.1.

4.6.2.2.3 Test at 100 °F. The four 1-inch-wide specimens selected for this test (see 4.6.2.2.1) shall be tested the same as those specimens tested at room temperature except that specimens shall be clamped in a forced draft circulating air oven maintained at 100 ± 2 °F with a weight of 2 pounds \pm 1/2 ounce acting on the free end of the specimen for 1 hour. The rate of air circulation shall be held to the minimum required to maintain uniform temperature throughout the oven. In no case shall the rate of air circulation cause any movement of the weighted specimens. The weights shall be attached after the specimens and test clamp fixtures have been placed in the oven. The weights shall be removed prior to taking the specimen from the oven in order to avoid excessive loading due to swaying action. After one hour, the weights shall be removed and the specimen examined for separation of the heat-sealed faces. Any evidence of delamination of one ply away from the other in the heat-sealed area as specified in 4.6.2.2.1 shall be cause for rejection.

4.6.2.2.4 Test at 160 °F. The four 1-inch-wide specimens selected for this test (see 4.6.2.2.1) shall be tested the same as those at 100 °F except that the weight shall be $10 \pm \frac{1}{2}$ ounces, and the temperature in the forced draft circulating air oven shall be 160 ± 2 °F. The rate of air circulation shall be held to the minimum required to maintain uniform temperature throughout the oven. In no case shall the rate of air circulation be such as to cause any movement of the weighted specimens.

4.6.2.3 Seam strength (sealed before aging).

4.6.2.3.1 Test specimens. The four specimens for this test shall be folded in half with the crease parallel to the long axis. The open or unfolded length shall be heat-sealed by clamping in the sealer. This line identifies the actual seam separation. The folded length of the test section shall then be cut off 1/2 inch from the end. After heat-sealing, the samples shall be aged in a forced draft circulating air oven maintained at 160 ± 2 °F for 12 consecutive days (288 hours). After aging, 1-inch-wide specimens, as specified in 4.6.2.2.1, shall be cut from the sections for test at room temperature, 100 °F, and 160 °F.

4.6.2.3.2 Test at room temperature. The four 1-inch-wide specimens selected for this test (see 4.6.2.3.1) shall be tested as specified in 4.6.2.2.2.

MIL-PRF-81705D

4.6.2.3.3 Test at 100 °F. The four 1-inch-wide specimens selected for this test (see 4.6.2.3.1) shall be tested as specified in 4.6.2.2.3.

4.6.2.3.4 Test at 160 °F. The four 1-inch-wide specimens selected for this test (see 4.6.2.3.1) shall be tested as specified in 4.6.2.2.4.

4.6.2.4 Seam strength (sealed after aging).

4.6.2.4.1 Test specimens. The four specimens for this test, in the flat unsealed condition as taken from the sample roll shall be aged in a circulating air oven maintained at 160 ± 2 °F for 12 consecutive days (288 hours). After removal from the oven, the unsealed sections shall return to room temperature. Test specimens shall then be obtained as specified in 4.6.2.2.1.

4.6.2.4.2 Test at room temperature. The four 1-inch-wide specimens selected for this test (see 4.6.2.4.1) shall be tested as specified in 4.6.2.2.2.

4.6.2.4.3 Test at 100 °F. The four 1-inch-wide specimens selected for this test (see 4.6.2.4.1) shall be tested as specified in 4.6.2.2.3.

4.6.2.4.4 Test at 160 °F. The four 1-inch-wide specimens selected for this test (see 4.6.2.4.1) shall be tested as specified in 4.6.2.2.4.

4.6.3 Seam fabrication.

4.6.3.1 Preparation of test specimens. Four pouches sealed in accordance with the manufacturer's recommended sealing conditions shall be fabricated from the barrier material. Each pouch shall be prepared by cutting four specimens; two 2 1/2 by 5 1/2 inches, and two 5 1/2 by 5 1/2 inches. The pouch shall be fabricated by sealing as shown on figure 2. The butt seals projecting at 1/2-inch seams perpendicular to the faces shall be made prior to sealing the bottom. The butt seams shall be folded flat at the point of juncture with the bottom seams before the bottom seals are made.

MIL-PRF-81705D

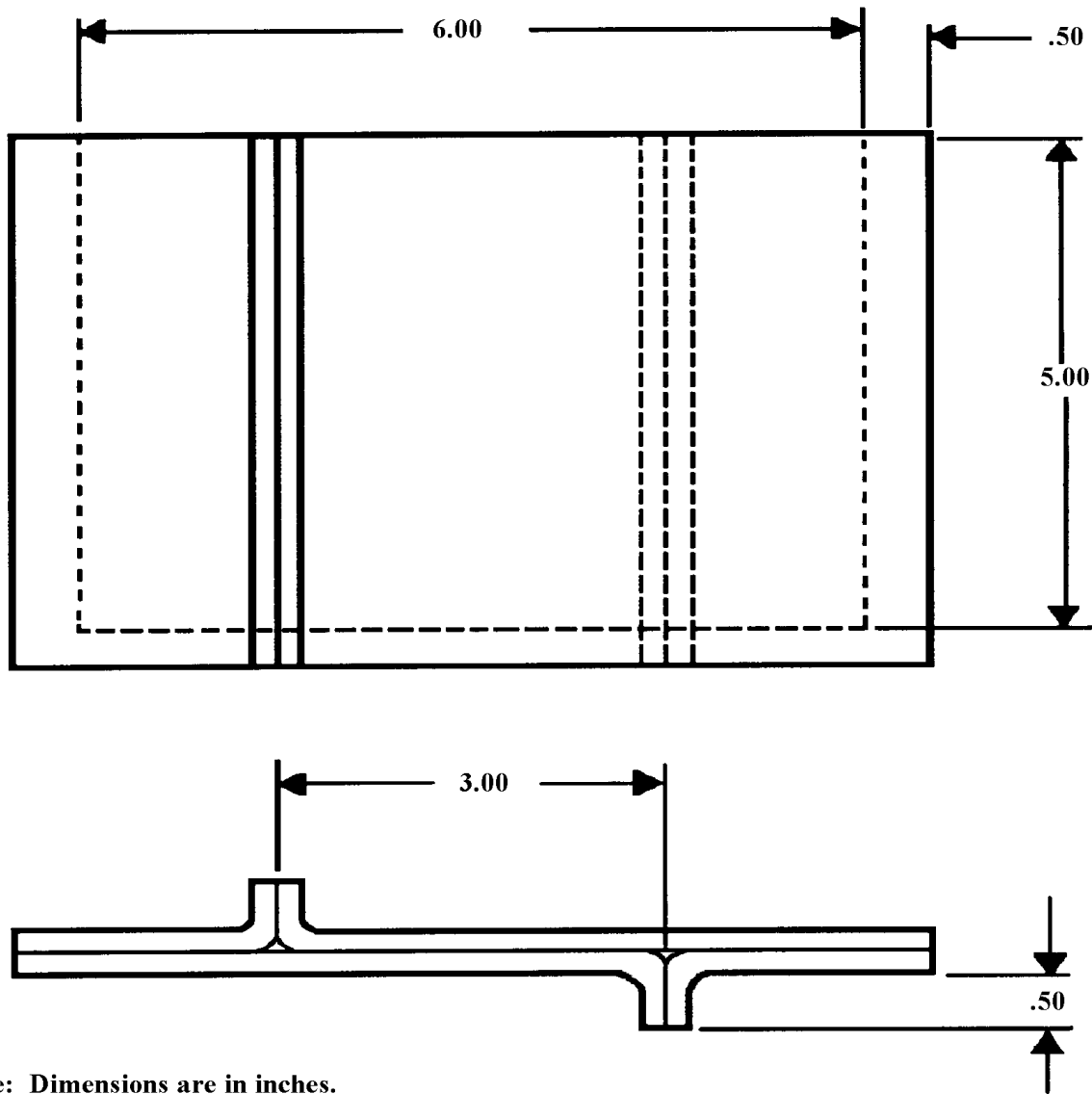

Note: Dimensions are in inches.

FIGURE 2. Pouch for seam fabrication test.

4.6.3.2 Procedure. A water solution, containing dye and a 1 percent Aerosol O.T. (Dioctyl Sodium Sulfosuccinate) or equivalent as approved by the qualifying activity, shall be made to produce a distinct color. The solution shall be poured into each sealed pouch to a level of two inches above the top of the bottom seam. The pouch shall then be suspended vertically. After a period of 15 minutes at room temperature, the pouches shall be examined for dye leakage at all seams and especially at the double seam junctions (the points where the vertical seams intersect the bottom seam at points other than at the corners of the pouch).

MIL-PRF-81705D

4.6.4 Aging resistance. Three specimens, 36 by 6 inches, cut from across the roll of material, at points which shall be not less than 1 yard apart, shall be used for this test.

4.6.4.1 Procedure. The specimens shall be subjected to the following aging cycle:

8 hours in a humidity chamber at 100 ± 2 °F and 90 to 95 percent relative humidity.
16 hours in a circulating air oven at 160 ± 2 °F.

The aging cycle shall be repeated every weekday, for five consecutive days. The specimens shall remain in the circulating air oven maintained at the conditions described above on Saturday, Sunday and holidays, except that holidays shall not exceed a total of two days over the entire aging period. The aging procedure shall continue for fourteen consecutive days. The specimens shall be folded loosely, hung, rolled loosely or laid flat in the test chamber during the aging period. At the conclusion of the aging period the specimens shall be returned to room temperature and examined, particularly at all edges, for delamination brought about by the aging exposure. No supplemental attempt to delaminate the material, such as prying or picking at the plies, shall be carried out. For purposes of this test, delamination shall occur if ply separation at any one given point extends in more than 1/2 inch from the edge with an edge length separation greater than 1 inch.

4.6.5 Waterproofness.

4.6.5.1 Test preparation. Flexing procedure shall be conducted in accordance with FED-STD-101, Method 2017, except that unaged specimens only shall be tested. Prior to flexing, the test specimens shall be conditioned for 30 minutes at -20 ± 2 °F and the flexing operation shall be conducted at -20 ± 2 °F.

4.6.5.2 Procedure. After flexing the specimen, the sleeve shall be removed, allow the specimen to come to room temperature and dry by wiping with an absorbent material or by placing in a circulating air oven maintained at 160 °F for 10 minutes. The sleeve shall be removed and made into a pouch by sealing one end. The pouch shall be filled with shredded absorbent paper. The pouch shall then be placed in a water solution containing 1 percent Aerosol O.T. and methyl violet for ten minutes. The pouch shall then be removed, wiped dry, and the shredded absorbent paper examined for dye stain.

4.6.6 EMI attenuation. The measuring technique is intended for determining Radio Frequency (RF) attenuation characteristics of the type I and type III material. Specimens shall be tested as received and after flexing in accordance with FED-STD-101, Method 2017, using the full stroke flexing motion prior to testing.

4.6.6.1 Preliminary steps. The following measurement technique shall be used at 500 MHz intervals from 1.0 to 10.0 GHz.

MIL-PRF-81705D

- a. An aperture of 7 by 7 inches shall be cut into the access panel of an RF shielded chamber.
- b. The test equipment shall consist of an RF signal generator with a transmit horn antenna as the RF source and a HP spectrum analyzer or EMI receiver with receive horn antenna as the measurement system. Test equipment shall be set up as shown on figure 3.
- c. The receive horn antenna shall be placed inside the RF shielded chamber and centered both horizontally and vertically with the 7 by 7 inch opening of the aperture at a distance that shall be not less than 1.65 feet from the test sample.
- d. The transmit horn antenna shall be placed outside the RF shielded chamber and centered both horizontally and vertically with the 7 by 7 inch opening of the aperture at a distance that shall be not less than 1.65 feet from the test sample.
- e. The total distance between the transmit horn antenna and the receive horn antenna shall be not less than 3.3 feet. This distance is not critical, but once set it shall not be changed during the testing without repeating both the open aperture and sheet metal/closed aperture setup tests.

MIL-PRF-81705D

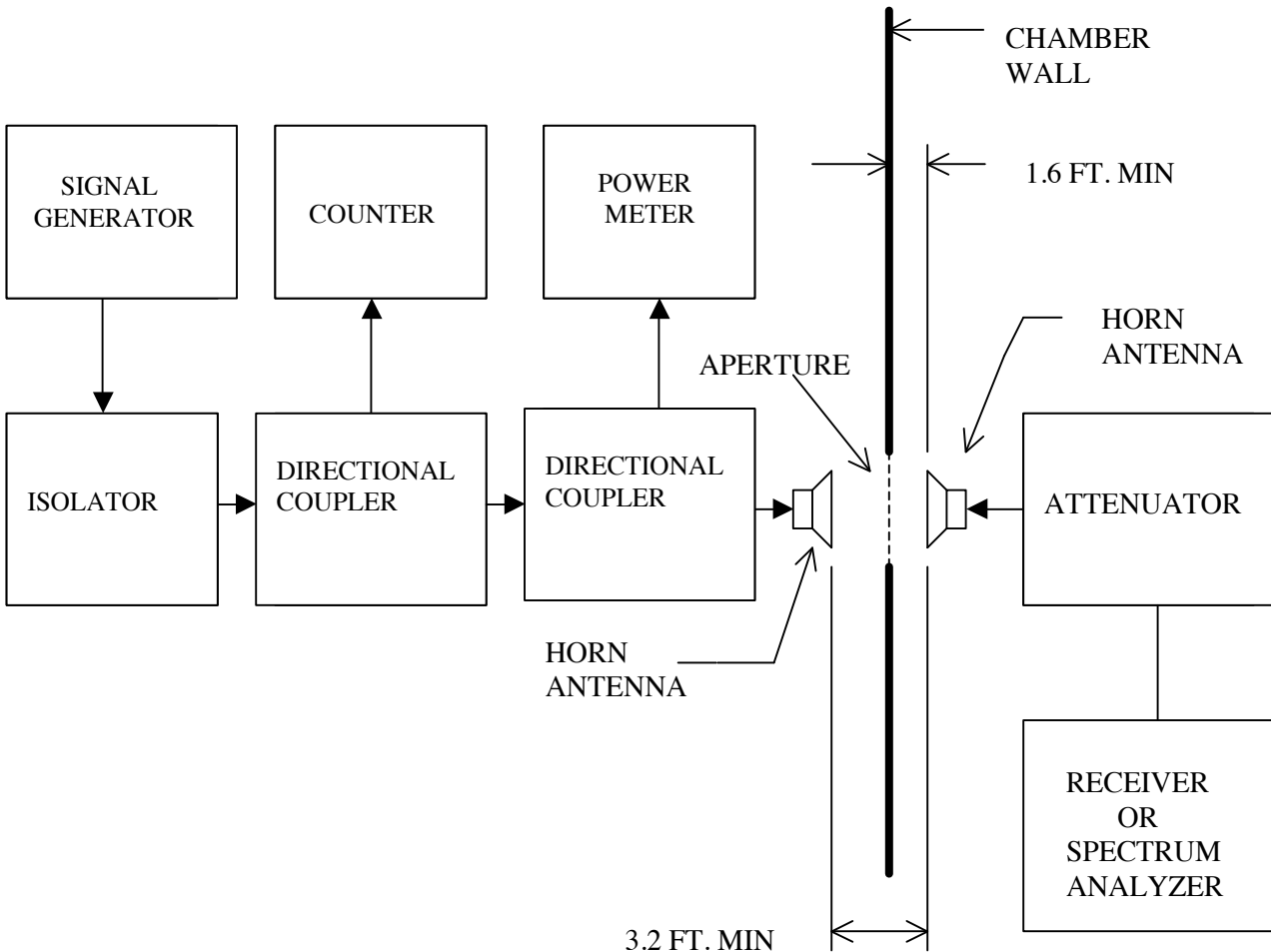

FIGURE 3. Test set-up for determining EMI attenuation characteristics (block diagram).

4.6.6.2 Test procedure.

- a. Keep the 7 by 7 inch aperture uncovered.
- b. The transmit horn antenna shall be positioned, as specified in 4.6.6.1, to produce dynamic range that shall be not less than 35 decibels, between an open aperture and a sheet metal/closed aperture, for the entire frequency range of 1.0 GHz through 10.0 GHz. This position shall be determined by placing the transmit horn antenna at the test position and adjusting the signal generator to produce a minimum signal level of 35 decibels above the noise, floor of the

MIL-PRF-81705D

spectrum analyzer or EMI receiver, with the 7 by 7 inch opening (aperture) uncovered. A sheet metal plate shall be placed over the opening and the test repeated at the same power output level used for the open aperture test to ensure that a dynamic range of over 35 decibels is achieved. A signal level shall be selected for each test frequency in order to provide the required dynamic range.

c. Tune receiver or spectrum analyzer to obtain a display or indication.

d. Record readings from signal generator (frequency and output level) and receiver or spectrum analyzer signal level.

e. Repeat steps (b), (c) and (d) at all test frequencies. Ensure that signal generator (frequency and output level) is the same as recorded in step (d).

f. Cut a square of sheet metal (same material as test barrier) 8 by 8 inches. Using silver epoxy or equivalent as approved by the qualifying activity, apply the adhesive evenly around the 7 by 7 inch open aperture such that a flat ribbon of 1/2 inch is present around the perimeter of the opening. Place the sheet metal square symmetrically over the opening with 1/2 inch overlap on all four sides and press evenly and firmly to ensure a secure bond between the two surfaces. Conductive tape or 7 inch magnetic strips also may be used to fasten the sheet metal or the test sample to the open aperture in place of the silver epoxy.

g. Repeat steps (b), (c) and (d) at all test frequencies. Ensure that the signal generator (frequency and output level) is the same as recorded in step (d).

h. Remove the sheet metal plate installed in step (f) and using the same procedure described in step (f), fasten the test sample to be tested. The outer surface of the test sample shall face the transmitting horn. Repeat steps (b), (c) and (d) at all test frequencies. Ensure that the signal generator (frequency and output level) and frequency shall be the same as recorded in step (d).

i. The difference (in decibels) between the spectrum analyzer or receiver's readings in step (d) and step (h) is the attenuation characteristics of the test sample. This reading shall not exceed the differences (in decibels) between the readings in step (d) and step (g).

4.6.7 Marking abrasion resistance.

4.6.7.1 Preparation of test specimens. Strips 3-inches-wide containing markings shall be cut so that the amount of markings shall be at maximum. The length shall allow for a bifold seam to be formed and stapled, the resultant strip shall be 3 inches wide by 18 inches long (see figure 4).

MIL-PRF-81705D

4.6.7.2 Procedure. The test bar shall be a hollow 5052 aluminum 1 3/8 to 1 1/2 inch diameter tube with a number 63 finish. The strip shall be hung over the bar with 0.9 ± 0.5 pounds weight attached to one end (see figure 4). The side with the print or raised embossing shall be in contact with the bar. The other end shall be pulled (stroked) at a rate of 50 to 70 strokes per minute for 1 minute. The stroke length shall be 13 to 16 inches. The angle of pull (stroke) shall be from 0 to 45 degrees. The strip shall be removed and the weight detached. The printing shall be examined for legibility, smear, and blurring.

4.6.8 Surface resistivity.

4.6.8.1 Test specimens. Specimens shall be large enough to accommodate testing equipment and shall be selected at random and in numbers to represent the variation of material. Specimens shall be selected across the length and width of the entire roll sample. A minimum of five specimens are required.

4.6.8.2 Conditioning of test specimens. Test specimens shall be conditioned at 12 ± 3 percent relative humidity and 73 ± 5 °F for at least 48 hours. Additional conditioning shall include flexing the specimens in accordance with FED-STD-101, Method 2017, using the full stroke flexing motion prior to testing.

4.6.8.3 Test environment. Perform tests in an atmosphere maintained at 73 ± 5 °F and 12 ± 3 percent relative humidity.

4.6.8.4 Test procedure. The testing procedure shall be in accordance with ASTM-D257. Use flat specimen electrode configuration for measuring volume and surface resistance or conductance. Samples shall be tested on the inner surface (side opposite the side containing the identification markings) and the outer surface of the barrier material. A surface resistivity value not within the range specified in table I, on any of the five specimens tested per sample shall be cause for rejection.

4.6.9 Electrostatic shielding test method.

4.6.9.1 Test specimens. Specimens, selected at random, shall consist of 4-inches-wide by 6-inches-deep bags (inner dimension, with a tolerance of minus 1/4 inch) constructed from roll stock material. Each bag shall be constructed from a single sheet of material folded in the middle then heat-sealed along two edges. A minimum of five specimen bags are required.

4.6.9.2 Conditioning of test specimens. Conditioning shall be as specified in 4.6.8.2.

MIL-PRF-81705D

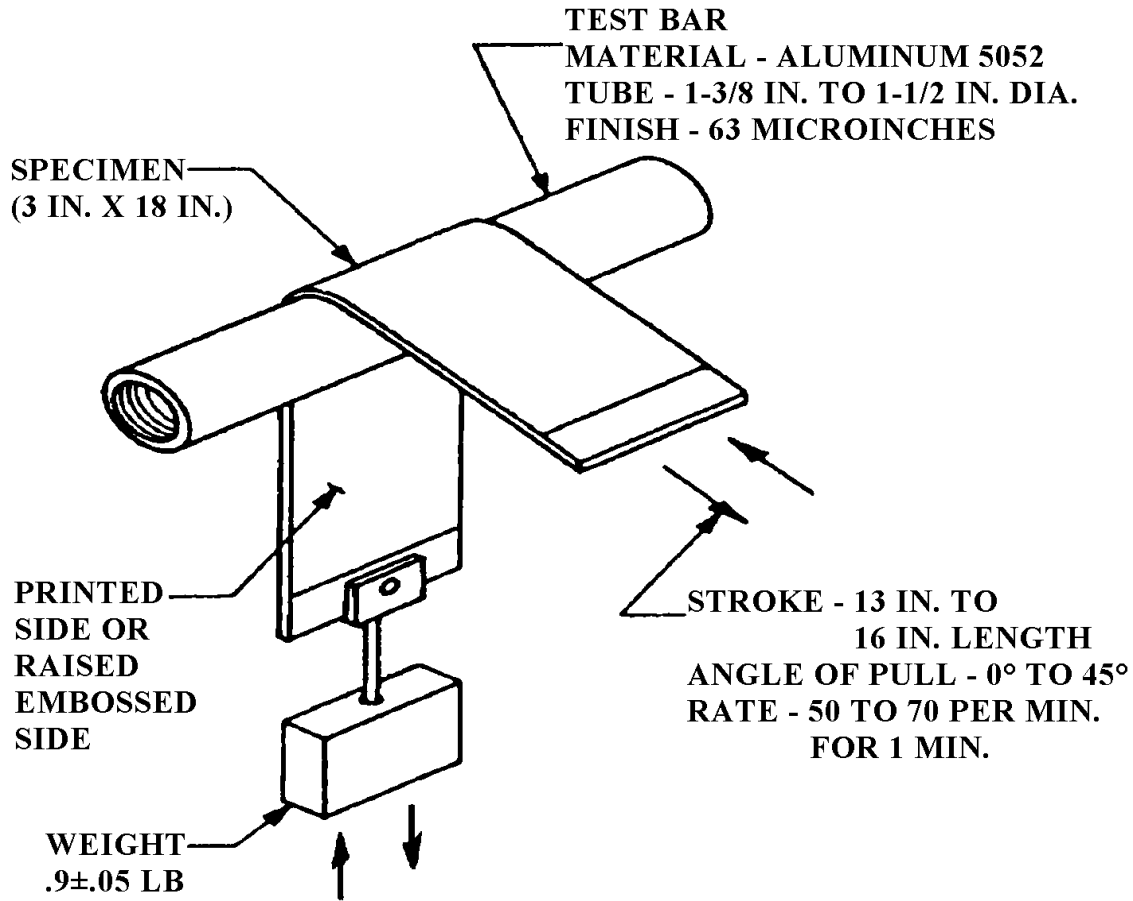

FIGURE 4. Apparatus for testing identity markings resistance to abrasion.

4.6.9.3 Test environment. Test shall be performed in an atmosphere maintained at 73 ± 5 °F and 12 ± 3 percent relative humidity.

4.6.9.4 Test procedure. The testing procedure shall be in accordance with the applicable appendix of EIA-541 (2 Probe Electrostatic Shielding Property Test). The test shall be performed at 1000 volts. A peak voltage higher than that specified in table I on any of the five specimens tested shall be cause for rejection.

5. PACKAGING.

5.1 Packaging. For acquisition purposes, the packaging requirements shall be as specified in the contract or order (see 6.2). When actual packaging of materiel is to be performed by DoD personnel, these personnel need to contact the responsible packaging activity to ascertain

MIL-PRF-81705D

requisite packaging requirements. Packaging requirements are maintained by the Inventory Control Point's packaging activity within the Military Department or Defense Agency, or within the Military Department's System Command. Packaging data retrieval is available from the managing Military Department's or Defense Agency's automated packaging files, CD-ROM products, or by contacting the responsible packaging activity.

6. NOTES

(This section contains information of a general or explanatory nature that may be helpful, but is not mandatory.)

6.1 Intended use. The barrier materials covered by this specification are intended for use in specialized military methods of preservation. The combination of all performance characteristics of MIL-PRF-81705; electromagnetic interference attenuation; electrostatic shielding; static decay; water vapor transmission rate; surface resistivity; waterproofness; transparency; marking abrasion resistance; thickness; aging; seam strength and fabrication; breaking strength; puncture; blocking and curl resistance; contact corrosivity; delamination; water resistance of marking, provides the necessary requirements for protection from exposure to the extremes of the navy/naval aviation environment. Navy/naval aviation items are exposed to high moisture, high salt concentration, transfer at sea, rough handling, and minimal storage conditions. There are no commercial equivalents that meet the physical, mechanical, and corrosion requirements necessary to protect materiel that is exposed to the operational naval aviation environment. Specifically, Specialized Method of Preservation, GX of MIL-STD-2073-1C use MIL-PRF-81705 as the premier source of barrier materials that provide watervaporproof and electrostatic discharge protection for applicable items encountering the above conditions. MIL-PRF-81705 provides the building blocks for applying Electrostatic Discharge Protective techniques approved under MIL-STD-2073-1C.

6.1.1 Type I use. Type I material is intended for use for watervaporproof, electrostatic and electromagnetic protection of microcircuits and semiconductor devices, such as diodes, field effect transistors, and sensitive resistors.

6.1.2 Type II use. Type II material is intended for use where transparency and static dissipation is required and contact with oil or grease is not contemplated.

6.1.3 Type III use. Type III material is intended for use where a transparent, waterproof, electrostatic-protective and electrostatic field protective barrier is required.

MIL-PRF-81705D

6.2 Acquisition requirements. Acquisition documents must specify the following:

- a. Title, number, and date of the specification.
- b. Issue of DoDISS to be cited in the solicitation, and if required, the specific issue of individual documents referenced (see 2.1).
- c. Type and class of barrier material (see 1.2).
- d. Form (rolls of tubing or sheeting or flat cuts) and size required (see 3.4).
- e. Packaging requirements (see 5.1).

6.3 Heat-seal equipment. In the interest of standardization and for ease of manipulation, all seals for test under this specification should be effected on a jaw-type heat-sealer. This, however, should not be construed as an indication of Governmental preference in regard to sealing equipment. It is not intended that the operating temperature of heat-sealing equipment be limited to 525 °F or less. While equipment may be operated at temperatures exceeding 525 °F to accomplish a seal, the barrier material must also be capable of being heat-sealed at temperatures of 525 °F or less.

6.4 Qualification. With respect to products requiring qualification, awards will be made only for products which are, at the time of award of contract, qualified for inclusion in Qualified Products List QPL-81705, whether or not such products have actually been so listed by that date. The attention of the contractors is called to these requirements, and manufacturers are urged to arrange to have the products that they propose to offer to the Federal Government tested for qualification in order that they may be eligible to be awarded contracts or purchase orders for the products covered by this specification. Information pertaining to qualification of products and the letter of authorization for submittal of sample may be obtained from: Commander, Naval Air Warfare Center Aircraft Division, Code 4.3.5.3, Building 562-3, Highway 547, Lakehurst, NJ 08733-5049.

Barrier material supplied under contract should be identical in every respect to the samples tested and found to meet the requirements of this specification. Any unapproved changes from the qualification sample should constitute cause for rejection for material submitted and for removal from the list of qualified products. However, acceptability under this specification is based on the performance characteristics of the barrier material, and since there is no color requirement, it is not mandatory that the color of the visible surfaces of the material supplied under contract be the same as the samples tested and accepted by the qualifying activity.

MIL-PRF-81705D

6.4.1 Submission of qualification samples and additional information. Prior to submitting samples for qualification testing, vendors will request authorization from the qualifying activity. Upon receipt of authorization, samples will be forwarded as directed. The qualifying activity will require the manufacturer to submit for review and approval, two copies for the manufacturer's test report, including the sample's material safety data sheet (see 6.6), the location and identity of the plant which produced the sample, and then item composition report. The samples should be plainly and durably marked with the following information:

Sample for Qualification Inspection

BARRIER MATERIAL, FLEXIBLE, ELECTROSTATIC PROTECTIVE,
HEAT-SEALABLE

Manufacturer's Name

Manufacturer's Code No.

Type

Class

Date of manufacture (month and year)

Submitted by (name) (date) for qualification inspection in accordance with requirements of MIL-PRF-81705D under authorization (reference authorizing letter).

6.5 Conformance inspection lot. For purposes of sampling, an inspection lot for examinations and tests should consist of all material of the same class made by the same process from the same components by one manufacturer and submitted for delivery at one time.

6.6 Material safety data sheets (MSDS). Contracting Officers will identify those activities requiring copies of completed material data safety sheets prepared in accordance with FED-STD-313. The pertinent government mailing addresses for submission of data are listed in FED-STD-313; and 29 CFR 1910.1200 requires that the material safety data sheet for each hazardous chemical used in an operation must be readily available to personnel using the material. Contracting Officers will identify the activities requiring copies of the material safety data sheet.

6.7 Metric conversion factors. Metric conversion factors are referenced in FED-STD-376.

6.8 Subject term (key word) listing.

Electromagnetic shielding

Packaging

Preservation

Water vapor transmission

6.9 Changes from previous issue. Marginal notations are not used in this revision to identify changes with respect to the previous issue due to the extent of the changes.

MIL-PRF-81705D

6.10 Amendment notations. The margins of this specification are marked with vertical lines to indicate modifications generated by this amendment. This was done as a convenience only and the government assumes no liability whatsoever for any inaccuracies in these notations. Bidders and contractors are cautioned to evaluate the requirements of this document based on the entire content irrespective of the marginal notations.

CONCLUDING MATERIAL

Custodians:

Army - GL

Navy - AS

Air Force - 11

DLA - CC

Preparing activity:

Navy - AS

(Project 8135-0748)

Review Activities:

Army – CR, SM

Navy – OS, SA, SH

Air Force – 70, 84

NOTE: The activities listed above were interested in this document as of the date of this document. Since organizations and responsibilities can change, you should verify the currency of the information above using ASSIST Online database at <http://www.dodssp.daps.mil>.