

INCH-POUND

MIL-PRF-63029J (AV)  
7 AUGUST 2014

---

SUPERSEDING  
MIL-PRF-63029H (AV)  
31 August 2012

## PERFORMANCE SPECIFICATION

### MANUALS, TECHNICAL: REQUIREMENTS FOR OPERATOR'S MANUALS AND CHECKLISTS FOR MANNED AND UNMANNED AIRCRAFT SYSTEMS

This specification is approved for use by the U.S. Army Research, Development and Engineering Command, Department of the Army, and is available for use by all departments and agencies of the Department of Defense.

#### 1. SCOPE.

1.1 General. This specification establishes the requirements needed to prepare digital technical manuals (TMs) describing operating procedures, checklists, and maintenance test flight (MTF) manuals for operators of Army Aircraft and Unmanned Aircraft Systems (UAS).

1.2 Classification. The TMs to be prepared in accordance with this specification include:

- 10 – Operator's Manual
- CL – Operator's and Crewmember's Checklist
- MTF – Maintenance Test Flight Manual

Comments, suggestions, or questions on this document should be addressed to U.S. Army Aviation and Missile Command, ATTN: AMSAM-MSS-LP, Redstone Arsenal, AL 35898-5000. Since contact information can change, you may want to verify the currency of this address information using the ASSIST Online database at <https://assist.dla.mil>.

AMSC N/A

AREA TMSS

DISTRIBUTION STATEMENT A. Approved for public release; distribution is unlimited.

## MIL-PRF-63029J

1.3 Figures. In the event of a conflict between the text and the illustrations, the text of this document takes precedence over the figures.

## 2. APPLICABLE DOCUMENTS.

2.1 General. The documents listed in this section are specified in sections 3, 4, or 5 of this specification. This section does not include documents cited in other sections of this specification or recommended for additional information or as examples. While every effort has been made to ensure the completeness of this list, document users are cautioned that they must meet all specified requirements documents cited in sections 3, 4, or 5 of this specification, whether or not they are listed.

### 2.2 Government documents.

2.2.1 Specifications, standards, and handbooks. The following specifications, standards, and handbooks form a part of this document to the extent specified herein. Unless otherwise specified, the issues of these documents are those cited in the solicitation or contract.

#### DEPARTMENT OF DEFENSE STANDARD/DEPARTMENT OF DEFENSE HANDBOOK

MIL-STD-3013	Glossary of Definitions, Ground Rules, and Mission Profiles to Define Air Vehicle Performance Capability
MIL-STD-40051-2	Preparation of Digital Technical Information for Page-Based Technical Manuals
MIL-HDBK-1222	Guide to the General Style and Format of U.S. Army Work Package Technical Manuals
MIL-HDBK-310	Global Climatic Data for Developing Military Products

(Copies of these documents are available online at <http://assist.dla.mil/quicksearch> or Standardization Document Order Desk, 700 Robbins Avenue, Building 4D, Philadelphia, PA 19111-5094.)

2.2.2 Other Government documents, drawings, and publications. The following other Government documents, drawings and publications form a part of this document to the extent specified herein. Unless otherwise specified, the issues are those cited in the solicitation or contract.

#### ARMY REGULATIONS (AR)/DEPARTMENT OF ARMY PAMPHLETS (DA PAM)

AR 25-30	The Army Publishing Program
AR 25-52	Authorized Abbreviations, Brevity Codes, and Acronyms
AR 95-1	Flight Regulation
AR 95-2	Airspace, Airfields/Heliports, Flight Activities, Air Traffic Control, and Navigational Aids

## MIL-PRF-63029J

AR 95-23	Unmanned Aircraft System Flight Regulations
AR 385-10	The Army Safety Program
AR 385-63	Range Safety
DA PAM 25-40	Army Publishing: Action Officers Guide
DA PAM 385-10	The Army Safety Program
DA PAM 385-63	Range Safety
DA PAM 738-751	Functional Users Manual for the Army Maintenance Management System—Aviation

(Copies of these publications are available in electronic format through the Army Publishing Directorate website at <http://www.apd.army.mil/>).

## FIELD MANUALS

FM 3-04.203	Fundamentals of Flight
FM 3-04.240	Instrument Flight for Army Aviators
FM 4-25.11	First Aid

(Copies of these publications are available in electronic format through the Army electronic publications and forms website at <http://atiam.train.army.mil/>).

## TECHNICAL MANUALS (TM)/TECHNICAL BULLETINS (TB)

TB 55-9150-200-24	Engine and Transmission Oils, Fuels, and Additives for Army Aircraft
TM 1-1500-328-23	Aeronautical Equipment Maintenance Management Policies and Procedures
TM 55-1500-342-23	Aircraft Weight and Balance
TM 750-244-1-5	Procedures for the Destruction of Aircraft and Associated Equipment to Prevent Enemy Use

(Copies of these publications are available in electronic format through the Army electronic publications and forms website at <https://www.logsa.army.mil/>).

## DOD DIRECTIVES

DoD Directive 5230.24	Distribution Statements on Technical Documents
-----------------------	--

(Copies of this publication are available in electronic format through the DoD Issuances website at <http://www.dtic.mil/whs/directives/>).

## MIL-PRF-63029J

2.3 Order of precedence. Unless otherwise noted herein or in the contract, in the event of a conflict between the text of this document and the references cited herein (except for related specification sheets), the text of this document takes precedence. Nothing in this document, however, supersedes applicable laws and regulations unless a specific exemption has been obtained.

### 3. REQUIREMENTS.

3.1 General. This section provides the technical content requirements for the operator's manuals, checklists and MTF manuals. Technical content requirements (3.5 through 3.7) shall deal with the specific technical data aspects of operator's manuals, checklists and MTF manuals. The style and format requirements for the development of operator's manuals, checklists and MTF manuals are provided in Appendix A through Appendix E of this specification.

3.2 Selective application and tailoring. MIL-PRF-63029J contains some requirements that may not be applicable to the preparation of all technical manuals. Selective application and tailoring of requirements contained in MIL-PRF-63029J are the responsibility of the acquiring activity and shall be accomplished through the use of the matrixes provided in Appendix A. The applicability of some requirements is also designated by one of the following statements: unless specified otherwise by the acquiring activity; as/when specified by the acquiring activity; or when specified by the acquiring or proponent activity.

3.3 Preparation of digital data for electronic delivery. Technical manual data prepared and delivered digitally in accordance with this specification shall be Extensible Markup Language (XML) tagged using the Document Type Definitions (DTDs) and the XML Stylesheet Language (XSL), or style sheets. Refer to 3.3.2 for information on obtaining or accessing the DTDs and style sheets.

3.3.1 Use of the DTDs/Style sheets. The DTDs referenced in this specification interpret the technical content and structure for the functional requirements contained in this specification and are mandatory for use. The style sheets referenced herein interpret the style and format. As specified by the contracting activity, XSLs or style sheets may be used to produce final reproducible paper copy for all TMs prepared in accordance with this specification. Within this specification, when a specific tag set is to be used for data, that tag set name is identified between "< >" marks following the title of the paragraph.

3.3.2 Obtaining the DTDs/Style sheets. The DTDs, style sheets, associated tag and attribute descriptions, which are XML constructs, may be obtained from the AMCOM Publications website (pubsweb). Additionally available on the pubs web website are files containing documentation of the deleted, changed, and added elements between the legacy XML DTD and the current XML DTD. The AMCOM Pubs web assets may be obtained from <https://pubsweb.redstone.army.mil/DTD-FOSI/DTD-N-FOSI.html>.

## MIL-PRF-63029J

3.4 The use of “shall”, “should”, and “may”. The use of “shall” is used to express a binding requirement. “Should” and “may” are used to express non-mandatory requirements.

3.5 Operator’s manual (-10).

3.5.1 General. The operator’s manual shall describe briefly and concisely the operation of the complete aircraft. UAS shall include ground stations and other elements in addition to the actual air vehicles. The description of aircraft, aircraft systems, sub-systems, and components shall contain only that detail required to explain the operation, operational procedures, and checks necessary for the pilot to safely and efficiently operate the aircraft, aircraft systems, and mission equipment during flight and ground operation.

3.5.2 Hierarchical breakdown. An Operator’s Manual begins with: volumes (if required), chapters, sections and subsections. Each division used should have at least two occurrences (for example where there is a Volume 1, there should be a Volume 2; where there is a Chapter 1, there should be a Chapter 2; etc.). Multiple volumes should be partitioned only between chapters.

3.5.2.1 Volume size. Division into volumes shall occur when the number of printed pages (excluding pocket TMs) exceeds 1,000 pages or 500 sheets. Each volume shall not exceed 1,000 pages or 500 sheets. An MTF or CL (4 ½ x 8 inches) volume shall not exceed 500 pages or 250 sheets. Foldouts are counted in page units (sheets).

3.5.2.2 Volume content. Each volume of a series shall display the TM number on its cover and all pages that make up the volume. Each volume of a series shall contain a title block page and table of contents. The first volume shall contain a complete (including all volumes information) table of contents.

3.5.3 Chapters. Each operator’s manual prepared in accordance with this specification shall be divided as follows:

Front Matter

Chapter 1 – Introduction

Chapter 2 – Aircraft and Systems Description and Operation

Chapter 3 – Avionics

Chapter 4 – Mission Equipment

Chapter 5 – Operating Limits and Restrictions

Chapter 6 – Weight/Balance and Loading

## MIL-PRF-63029J

Chapter 7 – Performance Data

Chapter 8 – Normal Procedures

Chapter 9 – Emergency Procedures

References

Abbreviations and Terms

Index

Authentication Page

Foldouts (if included)

DA Form 2028

Metric Conversion Chart

### 3.5.4 Front Matter <front>.

3.5.4.1 Cover <cover>. Covers shall be prepared in accordance with Figure 1 (note the distribution statement). Additional detailed requirements for the front cover content information are described in 3.5.4.1.1 through 3.5.4.1.6. Following the TM title, the following notices shall be provided in the order listed below:

- a. TM number <tmidno>.
- b. Single volume supersedure notice for revisions only <super> (as applicable).
- c. TM title <prttitle>.
- d. National stock number (NSN) <nsn> for item(s) covered.
- e. End Item Code (EIC) <eic>, as specified in the Army Master Data File (AMDF).
- f. Volume notice (as applicable).
- g. Export control notice warning <export> (as applicable).
- h. Distribution statement <dist>.
- i. Destruct notice <destr> (as applicable).

## MIL-PRF-63029J

- j. Disclosure notice <discl> (as applicable).
- k. Multiple-volume supersedure notice for revisions only<super> (as applicable).
- l. Service nomenclature <servnomen>.
- m. Publication Date <pubdate>.

3.5.4.1.1 Volume notice <volnot>. Multiple-volume manuals shall contain a statement identifying all volumes required to complete the manual set.

3.5.4.1.2 Export control notice <export>. For those pubs with export controlled data, the following export control notice contained in DoD Directive 5230.24 shall be included:

“WARNING - This document contains technical data whose export is restricted by the Arms Export Control Act (Title 22, U.S.C., Sec 2751, et seq.) or the Export Administration Act of 1979 (Title 50, U.S.C., App. 2401 et seq.), as amended. Violations of these export laws are subject to severe criminal penalties. Disseminate in accordance with provisions of DoD Directive 5230.25.”

3.5.4.1.3 Distribution statement <dist>. All TMs shall have a distribution statement placed on the front cover for each manual or revision. The appropriate distribution statement shall be provided by the acquiring activity (6.2) as selected from DoD 5230.24.

3.5.4.1.4 Destruction notice <destr>. All TMs marked with distribution statements "B", "C", "D", "E", "F", or "X" shall be marked with the following destruction notice unless otherwise provided by the acquiring activity (6.2):

“Destruction Notice – Destroy by any method that will prevent disclosure of contents or reconstruction of the document.”

3.5.4.1.5 Disclosure notice <discl>. Unless specified otherwise by the acquiring activity (6.2), the following disclosure notice shall be placed on the front cover of all classified and unclassified TMs except those with distribution statement A:

"This information is furnished upon the condition that it will not be released to another nation without the specific authority of the Department of the Army of the United States, that it will be used for military purposes only, that individual or corporate rights originating in the information, whether patented or not, will be respected, that the recipient will report promptly to the United States, any know nor suspected compromise, and that the information will be provided substantially the same degree of security afforded it by the Department of Defense of the United States. Also, regardless of any other markings on the document, it will not be downgraded or declassified without written approval of the originating United States agency."

## MIL-PRF-63029J

3.5.4.1.6 Supersedure notice <super>. The supersedure notice shall be placed on the cover and title page when the manual is revised and supersedes all other manuals and changes. A single manual supersedure notice shall appear immediately below the TM Number. A multi-volume manual supersedure notice shall be the last notice prior to the service nomenclature. The applicable portions of the following notice shall be used:

“This manual supersedes (applicable manual number) dated (date of superseded document), including all changes.”

3.5.4.2 Warning page <warnsum>. A warning page(s) shall include each general type of warning and warning symbol used within the TM. The warning page shall not include a word-for-word repetition of all the warnings in the TM. It shall be limited to alerting the user of the different types of hazards in general terms including general hazardous subject data such as radiation, chemicals, high voltage, gas pressure, laser light, bird strikes/wildlife hazards, etc. that will be encountered in operating and maintaining the aircraft or equipment. The warning page shall also include first aid data. The warning page (Figure 2) shall start on a right-hand page immediately following the cover. The warning page shall consist of the following in the order specified below:

- a. First aid data.
- b. Warning icons. (as applicable)
- c. Warnings data. (as applicable)
- d. Hazardous materials icons. (as applicable)
- e. Hazardous materials descriptions. (as applicable)

3.5.4.2.1 First Aid Data. First aid data shall be included in warning summary. The first paragraph shall reference FM 4-25.11, First Aid. Any additional first aid data not described in FM 4-25.11 shall be described in this section.

3.5.4.2.2 Warning and hazardous materials icons. Use of standardized icons to improve readers' recognition of hazards is allowed. Approved icons for use in technical manual warnings are available online at <https://www.logsa.army.mil/mil40051/tmsspecs.cfm>. Warning icons used shall be defined in the warning summary.

3.5.4.2.2.1 Development of icons. Icons are enclosed in a square or rectangular box. The signal word(s) for icons appear outside the box below the icon(s).

3.5.4.2.2.2 Safety warnings with icons. The approved safety warning icons can be used in conjunction with the WARNING or CAUTION header and description of the hazard. For additional information on the use and placement of warnings and icons, refer to MIL-STD-40051-1 and -2.



## MIL-PRF-63029J

3.5.4.3 Change transmittal page <chginsst>. A change transmittal page (Figure 3) shall be prepared for each change and shall be included in the change package. The change transmittal page shall not be numbered and shall be located following the warning summary. The change transmittal page shall contain the change number, authority notice address, change date, print title information (nomenclature, model, NSN, and EIC) and distribution statement/block. When the manual has been reviewed for the presence of environmental and hazardous material information, the ODC (Ozone Depleting Chemical) statement provided on the abbreviated title page shall be repeated above the distribution statement/block. The list of pages for removal and insertion shall be provided.

3.5.4.4 List of effective pages <lep>. The list of effective pages (Figure 4) shall be a complete list of all manual pages, including abbreviated title page, list of effective pages currently in effect, table of contents pages, warning pages, blank pages, deleted pages, added pages, and foldout pages. The list of effective pages shall include a statement of the total number of pages in the manual. The list of effective pages shall be updated for each change or revision. The listing shall be held to a minimum by grouping numbers where applicable. The page numbers for a blank page and the printed side of the sheet shall be listed as separate numbers even though a double number shall appear on the printed side of the sheet. Appropriate change numbers shall be indicated for each page that is changed. As appropriate, the words "Deleted," "Blank," or "Added," shall be placed beside the page number that is affected.

3.5.4.5 Abbreviated title page <title page>. A TM shall have an abbreviated title page (Figure 5). The abbreviated title page shall follow the list of effective pages.

3.5.4.5.1 Statements and Notices. An applicable reporting errors and recommending improvements statement shall be included. The reporting errors and recommending improvements statement shall be provided by the acquiring activity (6.2) since this statement is subject to change either due to an address change or statement tailoring. The abbreviated title page shall contain the same statements and notices as provided on the cover (3.5.4.1). The statement/notices shall follow the reporting errors and recommending improvements statements. Space permitting, the table of contents (TOC) shall immediately follow the abbreviated title page information.

3.5.4.5.2 Environmental/hazardous material information. When the manual has been reviewed for the presence of environmental and/or hazardous material information, a statement similar to the following ODC <odcstatement> and/or Hazardous Materials statement <hazmatstatement> shall be provided on the abbreviated title page:

**OZONE DEPLETING CHEMICALS INFORMATION**

This document has been reviewed for the presence of Class I Ozone Depleting Chemicals. As of *provided date*, the status is: All references to Class I Ozone Depleting Chemicals have been removed from this document by substitution with chemicals that do not cause atmospheric ozone depletion.

## MIL-PRF-63029J

**HAZARDOUS MATERIALS INFORMATION**

This document has been reviewed for the presence of Solvents used as cleaning solutions containing hazardous materials as defined by EPCRA 302 and 313 lists by the engineering, environment and logistics oversight office. As of the base document dated *provided date*, all references to cleaning solvents containing hazardous materials have been removed from this document by substitution with non-hazardous materials where possible.

3.5.4.6 Table of contents <contents>. The TOC shall list all chapters and sections in the same order and with the same title used in the text. If space allows, the TOC (Figure 5) shall be placed on the abbreviated title page, or begin on the first right-hand page following the abbreviated title page. The first volume of a multi-volume paper manual shall contain a master TOC for all volumes. Each of the remaining volumes shall have its own TOC. Refer to MIL-STD-40051-2 for the preparation requirements for a multi-volume TOC.

3.5.5 Chapter 1 – Introduction <chapter1>. This chapter shall consist, at a minimum, of introductory material that applies to the manual as a whole.

3.5.5.1 General. A brief summary of the contents of the manual shall be provided.

3.5.5.2 Explanation of warnings, cautions, and notes. An explanation of the use of warnings, cautions, and notes that the operators will find in the TM and the importance of observing these safety alerts shall be provided. The following shall be included:

**“WARNINGS, CAUTIONS, AND NOTES.** Warnings, cautions, and notes are used to emphasize important and critical instructions and are used for the following conditions:

**WARNING**

Identifies and highlights an essential operating or maintenance procedure, practice, condition, statement, etc. which if not strictly observed, could result in injury to, death of, or long term health hazards to personnel.

**CAUTION**

Identifies and highlights an essential operating or maintenance procedure, practice, condition, statement, etc., which if not strictly observed, could result in damage to or destruction of equipment, or loss of or degraded mission effectiveness.

## MIL-PRF-63029J

**NOTE**

Identifies and highlights an essential operating or maintenance procedure, condition, or statement.”

3.5.5.3 Description. A succinct summary of the aircraft’s description and primary mission, omitting any extraneous mission capabilities statements, shall be provided. The statement similar to the following shall be included:

“This manual contains the best operating instructions and procedures for the (insert aircraft designation), under most circumstances. The observation of limitations, performance and weight/balance data provided is mandatory. The adherence to procedures is mandatory except when modifications are required because of multiple emergencies, adverse weather, terrain, etc. Basic flight principles are not included. **THIS MANUAL SHALL BE ACCESSIBLE BY THE OPERATOR IN THE AIRCRAFT DURING ALL FLIGHTS.**”

or for UAS:

“This manual contains the best operating instructions and procedures for the (insert aircraft designation), under most circumstances. The observation of limitations, performance and weight/balance data provided is mandatory. The adherence to procedures is mandatory except when modifications are required because of multiple emergencies, adverse weather, terrain, etc. Basic flight principles are not included. **THIS MANUAL SHALL BE ACCESSIBLE TO THE OPERATOR DURING ALL FLIGHTS.**”

3.5.5.4 Army Aviation Safety Program. The following statement shall be provided:

“Reports necessary to comply with the Army Aviation Safety Program are prescribed in DA PAM 385-10”.

3.5.5.5 Destruction of Army materiel. Information on procedures for destroying Army materiel to prevent enemy use shall be included. Reference shall be made to TM 750-244-1-5.

3.5.5.6 Forms and records. Flight records and aircraft maintenance records which are used by the operators and crewmembers shall be described. References shall be made to DA Pam 738-751 and TM 55-1500-342-23.

3.5.5.7 Explanation of change symbols. An explanation of the use of change symbols shall be included. An example of this explanation shall be as follows:

“Changes to the text and tables, including new material on added pages shall be indicated by a vertical bar in the outer margin extending close to the entire area of the material affected. Pages with emergency markings, which consist of black diagonal lines around three edges, shall have the vertical bar or change symbol placed along the outer margins

## MIL-PRF-63029J

between the text and the diagonal lines. Change symbols show current changes only. A miniature pointing hand symbol is used to denote a change to an illustration. However, a vertical bar in the outer margin, rather than miniature pointing hands, shall be utilized when there have been extensive changes made to an illustration.”

Change symbols shall not be used to indicate changes in the following:

- a. Introductory material.
- b. Indexes and tabular data where the change cannot be identified.
- c. Correction of minor inaccuracies, such as spelling, punctuation, relocation of material, etc., unless such correction changes the meaning of instructive information and procedures.
- d. Blank spaces resulting from the deletion of text, and illustration, or a table.

3.5.5.8 Designator symbols. An explanation of designator symbols, along with a table of symbols used in the TM shall be provided.

3.5.5.9 Explanation of the use of shall, will, should, and may. A statement similar to the following shall be included in the introduction:

“Within this TM use “shall” whenever a TM expresses a mandatory requirement. “Will” may be used to express a declaration of purpose or procedural result. Use “should” to indicate a non-mandatory but preferred method of accomplishment. The word “may” can be used to indicate an acceptable method of accomplishment.”

3.5.5.10 Additional introductory information. Any additional introductory information that may be required such as explanatory information for appendices or indices shall be provided, as applicable.

3.5.6 Chapter 2 – Aircraft and Systems Description and Operation <chapter2>.

3.5.6.1 Section I – Aircraft <ch2sect1>. This section shall provide a complete but concise description of the aircraft. At a minimum, the following subjects and illustrations shall be included.

3.5.6.1.1 General. A description of the airframe and all aircraft systems and controls shall be provided in this chapter. Major assemblies such as fuselage, wings, and tail boom shall be described. Each compartment of the aircraft such as cockpits and cabins shall be described and illustrated as required. Individual sections (as noted in 3.5.6.1 through 3.5.6.16) shall be developed for the description and operation of the aircraft and each aircraft system.

## MIL-PRF-63029J

3.5.6.1.1.1 UAS. UAS manuals shall provide a complete description and shall include the entire system by major components such as Air Vehicle, Ground Control Shelter, Ground Control Station/Portable Control Station, Data Link, and Launcher. The description of each system and associated controls and equipment shall be brief and concise. Major UAS assemblies such as shelter, portable cases, and workstations shall be described. Each workstation of the ground control station shall be described and illustrated as required. Illustrations shall be used to identify and locate the systems, controls and equipment.

3.5.6.1.1.2 Interactive Displays. For aircraft equipped with interactive displays, (i.e. multifunction display (MFD), primary function display (PFD), etc.), the data management system, including the interactive display, shall be described in this chapter. For each section within this chapter that describes a subsystem, the appropriate top page of the interactive display, including each button, shall be fully described and explained. When needed for clarity, illustrations of representative items displayed on the interactive display shall be included throughout the TM.

3.5.6.1.1.3 Emergency systems. Emergency systems may be located in Chapter 9 at the discretion of the acquiring activity (6.2). When this is done, include the following statement in the section “Emergency equipment information is located in Chapter 9.”

3.5.6.1.1.4 Controls. Each control contributing to the operation of a system shall be described and its location given. The function of the control and the end result produced when the control is moved to each of its possible positions shall be included in the description. Any effect which this control may have on other systems, or which they may have on the control shall be stated. If movement of the control requires any special action because of locks, gates, etc., it shall be so stated. When feasible, a separate paragraph and illustration shall be devoted to each control. It shall be preferable to divide the control description into two portions, normal controls and emergency controls, if emergency capabilities exist.

3.5.6.1.1.5 Indicators. All indicators, instruments, and warning devices that are a part of the aircraft system shall be described and illustrated. This shall include location, function, power source, and interpretation of the indications.

3.5.6.1.2 Illustrations and tables. The following illustrations and tables shall be included in Section I.

a. The aircraft’s general arrangement shall depict all access openings that will be checked during preflight of the aircraft (Figure 6). The general arrangement shall be placed as near to the beginning of Section I as practicable. These diagrams shall not include individual controls or aircraft systems. Diagrams that are needed for clarity shall be used. Two or more of these illustrations, such as crew movement diagrams and compartment diagrams, may be combined into one.

b. Illustrations showing minimum turning radius, ground clearance, dimensions and danger areas shall be included (Figure 7 and Figure 8). The minimum turn shall be based on a turn

## MIL-PRF-63029J

permitted on one wheel (tire hub), with and without power steering assist. Minimum ground clearance shall also be shown. The turning radius for skid equipped aircraft shall be based on turning the aircraft on an identifiable reference point on the aircraft or an identifiable reference point on the ground. An illustration shall be included showing danger areas around the aircraft for all modes of operations on or near the ground. Areas to be avoided to prevent damage to equipment or injury to personnel shall be depicted or described. These figures shall be provided for idle and maximum power. For rotary wing aircraft, illustrations shall be based on hover power required at maximum gross weight. Danger areas of main rotors, tail rotors, or propellers shall also be depicted.

c. Significant differences in design and operation between each aircraft series included in the manual shall be provided. Special emphasis shall be placed on features that will affect recognition and operation of the various series. This information shall be contained in a table (Figure 9).

d. Each major compartment, such as cockpit or cabin (Figure 10), that can carry payload or that can be entered by personnel shall be illustrated and identified.

3.5.6.1.3 UAS-specific illustrations and tables. As specified by the acquiring activity (6.2), the following illustrations and tables shall be provided for UAS manuals:

a. The ground control station or portable ground control stations general arrangement shall depict all access openings. These diagrams shall not include individual controls or systems. Diagrams that are needed for clarity shall be used. Two or more of these illustrations, such as crew movement diagrams and compartment diagrams, may be combined into one.

b. Danger areas around the ground control station for all modes of operations shall be illustrated. Areas to be avoided to prevent damage to equipment or injury to personnel shall be depicted or described.

c. Significant differences in design and operation between each ground control station series included in the manual shall be provided. Special emphasis shall be placed on features that will affect recognition and operation of the various series. This information shall be contained in a table.

d. The Ground Data Terminal/Antenna System general arrangement shall depict all areas that will be checked during preflight of the system. The general arrangement shall be placed as near to the beginning of Section I as practicable. These diagrams shall include all components of the Ground Data Terminal/Antenna System. Diagrams that are needed for clarity shall be used.

e. Illustrations showing setup distance, dimensions and danger areas shall be included. Minimum setup distance from UAS system or other structures shall also be shown. An illustration shall be included showing danger areas around the Ground Data Terminal/Antenna

## MIL-PRF-63029J

System. Areas to be avoided to prevent damage to equipment or injury to personnel shall be depicted or described.

f. Significant differences in design and operation between each Ground Data Terminal/Antenna System series included in the manual shall be provided. Special emphasis shall be placed on features that will affect recognition and operation of the various series. This information shall be contained in a table.

3.5.6.1.4 Landing gear system. Information describing the landing gear system shall be presented in detail for the operator's use. The following shall also be included.

- a. The steering system, including any special or unusual features, shall be described.
- b. The brake system, including all emergency provisions, shall be described. Brake provisions for aircraft equipped with floats shall also be described.

3.5.6.1.5 Instruments, panels and consoles. All instruments, panels, and consoles shall be described and illustrated. Several configurations may be covered by one illustration labeled typical. Minor variations in number or type of controls and instruments shall be indicated by detailed views to the illustration and by notations in the key. The panels or console shall be shown more than once when major changes in configuration are involved. UAS instruments, panels and consoles include those on or within the ground control station and on or within the Data Link System.

3.5.6.1.6 Canopies. The canopies shall be described and illustrated. Several configurations may be covered by one illustration labeled typical. All normal and emergency canopy controls, both external and internal, shall be described and illustrated.

3.5.6.1.7 Doors. All doors to include ramps, hatches, etc., controls for normal and emergency operations, and their sources of power shall be described.

3.5.6.1.8 Seats. As applicable, pilot and other flight compartment seat controls shall be described and illustrated. Emergency and ejection seat controls, inertia reels, harnesses, and seat belts shall be described and illustrated in detail, emphasizing how they are affected by other systems.

3.5.6.1.9 Ground Data Terminal/Antenna Systems. As required, this section shall provide a complete but concise description of the UAS System specific Data Link Systems used in transmitting flight control and payload information between the Ground Control Station and the Air Vehicle. These may include systems such as Ground Data Terminals, Portable Ground Data Terminals, Tactical Common Data Link System or Tactical Automated Landing Systems. At a minimum, the following subjects and illustrations shall be included.

3.5.6.1.10 Data Link System (UAS only). An overall description and general arrangement of the Data Link System shall be included. Major assemblies such as shelters, portable cases and

## MIL-PRF-63029J

workstations shall be described. Each workstation of the ground control station shall be described and illustrated as required. Diagrams needed for clarity shall be used.

3.5.6.1.11 Emergency recovery system (UAS only). All emergency equipment used in the recovery of unmanned aircraft shall be described (i.e., parachute systems, deadstick landing systems).

3.5.6.2 Section II – Emergency equipment <ch2sect2>. All emergency equipment, except that which forms part of a complete system, shall be described. For example, emergency landing gear controls shall be treated under the landing gear system and emergency fuel pumps under the fuel system. Emergency equipment in this section shall include, but shall not be limited to, hand fire extinguishers, engine fire extinguishers, emergency alarms, pyrotechnic equipment, axes, emergency hatches, signal lamps, ditching jackets, first aid kits, and survival kits. Emergency procedures shall be described only in Chapter 9. Illustrations showing locations of emergency equipment or systems shall be shown as needed but only in Chapter 9.

3.5.6.3 Section III – Engines and related systems <ch2sect3>. The engine and its related controls, as outlined in the following paragraphs shall be described.

3.5.6.3.1 Engines. The most important characteristics and special features of the engine shall be described. Model designation shall be included for all engines used in the subject aircraft. The following engine systems shall be described:

- a. Cooling system and controls such as cowl flaps and engine cooling fans.
- b. Engine/engine inlet anti-icing/deicing system.
- c. The engine fuel control system, which applies to jet and turbine powered aircraft and extends from the engine fuel control unit through the burner ring or combustor section. When applicable, special emphasis shall be placed on the emergency fuel control systems. Any special or unusual characteristics of the system shall also be described. Theory of operation shall not be included. Discussion of the throttle/power lever shall be included, as well as all systems affected by throttle/power lever operation.
- d. Information on all controls affecting the oil system.
- e. Ignition system controls.
- f. Starter controls.
- g. Infrared (IR) suppression system.
- h. Engine instruments and indicators. For the purpose of the operator's manual, the fuel and oil supply systems shall be treated as ending at the point where they deliver the fluid to the carburetor, fuel control unit, or the engine-driven oil pump.



## MIL-PRF-63029J

i. Engine management system.

j. Engine and APU fire detection/extinguishing system. The engine and APU fire detection/extinguishing system shall be described. The description, normal operation, and emergency operation for each of the systems shall be presented in the appropriate locations (emergency operation under emergency procedures, etc.), as applicable. The fire detection/extinguishing controls and displays shall be described.

3.5.6.4 Section IV – Fuel system <ch2sect4>. A full description of the fuel system shall be given. Coverage of drop tank release controls shall be included. Reference shall be made to fuel grades and specifications in Section XV, Servicing. Diagrams of the typical courses of fuel flow, including fuel system control positions for takeoff, cruising, landing, and emergency operation shall be included.

3.5.6.4.1 Controls and indicators. Fuel system controls and indicators shall be described.

3.5.6.4.2 Fuel system management. The fuel system management process shall be described, including auxiliary fuel, booster pump use, fuel transfer procedures, tank selection procedures, and courses of fuel flow. All possible courses of fuel flow, such as inoperative engines and failed boost pump, shall be included. The sequence in which fuel tanks must be used shall be stated with corresponding reasons (strength or balance). When applicable, reference shall be made to the pertinent portion of Chapter 6 when weight distribution becomes a problem. The required sequence of use of tanks to maintain a favorable center-of-gravity (CG) shall be described in detail. Remarks shall also be included regarding control of the aircraft if the transfer system fails and results in an unbalanced condition because of improper fuel distribution.

3.5.6.5 Section V – Flight control system <ch2sect5>. The flight control system and its location in the aircraft or UAS shall be described in its entirety. Flight controls, indicators, trim tabs, force trim, control locks, UAS datalinks, etc. shall be discussed as stated in paragraph 3.5.6.1. In addition, all other controls located on the control sticks, wheels, yokes, pedals, cyclic and collective, shall be discussed. Illustrations shall be provided for buttons, friction devices, locks, etc. Variations in controls between aircraft series or serial numbers, or both, shall also be shown.

3.5.6.5.1 Automatic flight control system. Detailed coverage of automatic stabilization equipment, stability augmentation control system, autopilot, and UAS automatic flight modes shall be provided. All modes of operation shall be described. If any additional systems are required to operate in conjunction with the stabilization equipment, a statement shall be included to that effect. Applicable precautionary data shall be included for conditions of partial or temporary electrical power failure, manual override, etc. When applicable, reference shall be made to navigation equipment descriptions and operations contained in Chapter 3.

## MIL-PRF-63029J

3.5.6.6 Section VI – Hydraulic and pneumatic systems <ch2sect6>. A description of all hydraulic and pneumatic systems shall be provided. At a minimum, test switches, indicators and gauges, caution/warning lights, and controls shall be discussed.

3.5.6.7 Section VII – Power train system <ch2sect7>. The power train system shall be described in detail to include the transmission and gearbox systems, drive shafting, system controls, and indicators.

3.5.6.8 Section VIII – Rotors or propellers <ch2sect8>. The propellers or rotors, as applicable, and their functions shall be described, including a detailed description of operation.

3.5.6.9 Section IX – Utility systems <ch2sect9>. A description of the defrosting, anti-icing/deicing, pressurization, oxygen, and rain removal systems and miscellaneous equipment shall be provided. Coverage shall be brief and shall focus on the location of the equipment and its controls, source of power, illustration of the controls (if not covered previously), and a brief discussion of function and operation. Control/switch panels that control several different utility systems shall only be illustrated once, if feasible. Information shall be included on all non-emergency equipment which is not part of a system. All miscellaneous equipment and normal and emergency operation procedures shall be included. Miscellaneous equipment shall include, but shall not be limited to, seats (other than pilot and flight engineer), hatches, heated blanket provisions, data case, benching gear, night flying curtains, ladders, relief equipment, food warmers, water containers, and tool kits. Items covered as aircraft loading equipment in Chapter 6 shall not be included here. Items dealing with aircraft servicing and ground handling shall be contained in servicing, parking, and mooring, Section XV.

3.5.6.10 Section X – Heating, ventilation, cooling, and environmental control systems <ch2sect10>. The heating, ventilation, cooling, and environmental control systems and their displays and controls shall be described. The description, normal operation, and emergency operation for each of these systems shall be discussed under separate paragraphs, as applicable.

3.5.6.11 Section XI – Electrical power supply and distribution systems <ch2sect11>. The electrical power supply and distribution systems and controls shall each be described and illustrated (Figure 11). Where pertinent, reference shall be made to auxiliary power systems that are described elsewhere. The external power source and the interaction between the auxiliary power plant and the electrical system shall be described. General arrangement and order of the primary system shall be covered first, followed by the secondary system.

3.5.6.11.1 DC power supply system. DC power supply system's shall include battery; starter-generators, generators, alternators and converters; indicators, gauges, and controls; circuit breaker and junction boxes; auxiliary power; and ground power.

3.5.6.11.2 AC power supply system. These systems shall include inverters and alternators; indicators, gauges, and controls; AC circuit breaker and junction box diagram; auxiliary power; and ground power.

## MIL-PRF-63029J

3.5.6.11.3 Breakers. The location of each circuit breaker panel shall be shown, and on standardized installation, each circuit breaker in the panels shall be identified. The illustration shall depict a typical installation of both systems (AC/DC) that may be combined on one illustration. In those instances where a standardized circuit breaker location does not exist, the location of circuit breakers or fuses shall be given.

3.5.6.12 Section XII – Auxiliary power unit <ch2sect12>. A description of the auxiliary power unit, controls, and its interaction with other systems shall be provided. Starting, stopping, and in-flight operating procedures shall be contained in Chapter 8 and emergency procedures in Chapter 9.

3.5.6.13 Section XIII – Lighting <ch2sect13>. Information shall be provided for, but shall not be limited to, formation, landing, fuselage, cabin, instruments, wheel well, taxi, navigation, and anti-collision lights. Coverage shall concern itself largely with locations, controls, power sources, and a discussion of functions. Illustrations may be used if equipment is not depicted in Chapter 2 or elsewhere.

3.5.6.14 Section XIV – Flight instruments <ch2sect14>. All flight instruments, indicators, gauges, and miscellaneous instruments and systems shall be described. Miscellaneous instruments and systems shall include such items as master caution systems, revolution per minute (rpm) high/low warning systems, trainer instrument panel, and clocks. Special problems, such as erroneous readings of the airspeed indicating system resulting from installation error or hovering, shall be included with references to correction charts, when applicable. Complex display systems shall be included under a separate primary heading. Line drawings shall be provided for all instruments. Each indicator, gauge, and control shall be shown (Figure 12). Each item shall be indexed or posted and references or links shall be used within the text as appropriate.

3.5.6.15 Section XV – Servicing, parking, and mooring <ch2sect15>. Servicing shall include, but shall not be limited to, flight crew oriented instruction for normal and closed circuit refueling and for replenishment of fuel, oil, hydraulic fluid, other fluids, and air in tires. Servicing shall also include all other such items involved in servicing the aircraft that a crew could be expected to perform while away from military maintenance support. Safety precautions to observe in servicing a particular tank or reservoir, such as grounding and prevention of fire hazards, shall be stated clearly. Servicing instructions shall be supplemented with a diagram showing locations of regular and alternate servicing points. NO STEP areas on walkways leading to tanks shall be indicated, with necessary precautions. References shall be made to graphs or data in other parts of the manual pertinent to servicing, such as tire pressure versus gross takeoff weight.

3.5.6.15.1 Servicing diagram. The servicing diagram shall depict each servicing point, including, but not limited to, tanks, reservoirs, filler caps, receptacles, oxygen bottles, and accumulators and shall be shown as viewed (Figure 13). Illustrations of site gauges and other indicators shall clearly depict proper servicing levels.

## MIL-PRF-63029J

3.5.6.15.2 Servicing information. Servicing data shall be in tabular form as shown in Figure 14. Each item of equipment including, but not limited to, engine, transmission, gearboxes, reservoirs (hydraulic, anti-icing), auxiliary power unit, and oxygen systems shall be listed under "System." Under the heading of "Specification," the military specification for the fuel, oil, fluid, or lubricant shall be listed, including references to any notes on temperature ranges, mixing of oil, etc. Fuel capacities shall also be listed to include total, servicing capacity, and usable capacity in U.S. measurements to the nearest tenth of a gallon, and metric equivalent.

3.5.6.15.3 Approved fuels. A tabular listing of primary, alternate, and emergency fuels shall be included, to include North Atlantic Treaty Organization (NATO) and commercial brand names authorized for use in the aircraft for which this manual applies. Warnings and cautions regarding additives shall be presented in the table. Also, restrictions on the use of any fuels shall be stated. The fuels contained in this listing shall only be those authorized for use by TB 55-9150-200-24 and by the acquiring activity (6.2). This information shall not be repeated in the manual.

3.5.6.15.4 Additional servicing instructions. Information shall include a listing of acceptable commercial engine oils as indicated in TB 55-9150-200-24 and as authorized for use in the aircraft (Figure 14).

3.5.6.15.5 Ground handling. Instructions and necessary precautions for ground handling of the aircraft shall be provided, including any information needed in extreme cold, heat, humidity, and dust. A description and instructions for operating any ground handling equipment involved shall also be provided. Left and right turning limits while towing (with or without external stores) shall be listed. Aircraft ground handling procedures relating to electronics equipment shall be stated when applicable.

3.5.6.15.6 Parking and mooring. Instructions for parking and mooring and the installation and stowage of aircraft covers, control locks, chocks, and tie down devices shall be described and illustrated. If feasible, ground handling, parking, and mooring may be shown on a single page illustration.

3.5.6.16 Additional sections <ch2sect additional> Additional sections may be added as required by the acquiring activity (6.2), i.e. Unique Equipment.

3.5.7 Chapter 3 – Avionics <chapter3>.

3.5.7.1 Section I – General <ch3sect1>. Except for mission avionics, a general overall description covering the avionics equipment configurations installed on a specific aircraft shall be provided. It shall include a brief description of the avionics equipment, its technical characteristics, capabilities, and locations. Mission avionics equipment shall be covered in Chapter 4.

## MIL-PRF-63029J

3.5.7.2 Sections II through IV <ch3sect2> through <ch3sect4>. For each item of avionics equipment contained within Sections II, III, and IV, the following information shall be included, as applicable. Additional sections shall be added by the acquiring activity (6.2) when required.

- a. Description.
- b. Controls and functions.
- c. Operation.
- d. Emergency operation (if applicable).
- e. Power source (if applicable).

3.5.7.2.1 Description. Avionics equipment shall be described in detail, including controls, indicators, instruments (if applicable), jacks, switches, and control panels, etc. Antenna locations shall be shown on appropriate illustrations. Antenna arrangement illustrations shall be included in Section I and referenced or linked when required or may be included in the applicable section where discussed. The proper techniques and procedures to be employed when operating the equipment shall also be described.

3.5.7.2.2 Controls and functions.

- a. For systems with interactive displays, (i.e. MFD, PFD, etc.) the Control/Indicator table may be omitted or altered at the discretion of the acquiring activity (6.2). The location and function of each control, including built-in test capability, contributing to the operation of the avionics equipment shall be listed. Each control panel shall be discussed separately. Reference or links shall be made to illustrations in Chapter 2 regarding controls and control panels.
- b. A tabular listing may be included for each control panel. (See Figure 15 for formatting example.) Each control or indicator shall be listed and its function defined in terms of what the operator of the control shall see, hear, or do as a result of the control setting. Terms of simple, immediate, and observable results shall be used. No attempt shall be made to give the operator the exact technical details about what happens when the control is used.
- c. A tabular listing may be included for each control display unit. (See Figure 15 for formatting example.) Each key that must be pressed shall be listed and a description of the function shall be included in the table.

3.5.7.2.3 Operation. A description of the operating details for each item of avionics equipment shall be provided. Whenever standard operational avionics data exist within the government, such data shall be furnished by the acquiring activity (6.2). Complete operating procedures shall be included as follows:

## MIL-PRF-63029J

a. When separate modes of operation are available, i.e., when the equipment may serve two or more systems, each mode shall be described. These shall be listed as modes of operation and each shall be briefly described.

b. The sequence of settings and the position to which the controls should be set to ensure proper results each time the equipment is energized shall be explained. Instructions shall be provided to prevent the possibility of damage through improper settings or sequence of operations. When appropriate, operating tolerances shall be called out. When operation of a unit is related to or dependent on the operation of a similar or independent control unit, this information shall be included in the operating procedure. Only those controls normally used by the operator shall be included; control adjustments that are the responsibility of maintenance personnel shall not be included.

c. If the configuration provides for a parallel operation from various positions in the aircraft, similar, separate, and complete coverage for each position shall be provided. When the procedure is identical to a position previously covered, it shall be covered by a reference to the previous procedure.

3.5.7.2.4 Emergency operations. When applicable, settings and operations of avionics equipment during emergency operations shall be described.

3.5.7.2.5 Power source. When applicable, a brief description of the power sources for avionics equipment shall be provided, including any special procedures or limitations using, but not limited to, external power and battery power.

3.5.7.3 Section II – Communications <ch3sect2>. Information for communications equipment installed in the aircraft shall be developed.

3.5.7.4 Section III – Navigation <ch3sect3>. A description of all navigation systems and indicators shall be provided. When there is doubt as to whether the system should be covered under communications or navigation, the primary use of the system shall be the deciding factor. A suitable reference shall be made in the manual to aid the operator in locating the material.

- a. Nondirectional radio beacon (NDB)
- b. Very high frequency (VHF) omni-directional range (VOR)
- c. VOR receiver check
- d. Tactical air navigation (TACAN)
- e. VOR/TACAN (VORTAC)

MIL-PRF-63029J

- f. Distance measuring equipment (DME)
- g. Navigational aid (NAVAID) service volumes
- h. Instrument landing system (ILS)
- i. Simplified directional facility (SDF)
- j. Microwave landing system (MLS)
- k. Long range navigation (LORAN)
- l. Inertial reference unit (IRU), inertial navigation system (INS), and attitude heading reference system (AHRS)
- m. Doppler radar
- n. Global positioning system (GPS)
- o. Wide area augmentation system (WAAS)
- p. Ground based augmentation system (GBAS) landing system (GLS)
- q. Precision approach systems other than ILS, GLS, and MLS
- r. Automatic direction finder (ADF)
- s. Gyro compass and magnetic indicators
- t. Marker beacon
- u. Flight director
- v. Autopilot
- w. Other

3.5.7.5 Section IV – Transponder and radar <ch3sect4>. All information for transponders, collision warning systems, and radar systems and indicators, as applicable, shall be provided.

3.5.7.6 Additional sections <ch3sect\_additional>. Additional sections may be added as required by the acquiring activity (6.2), i.e. Unique Equipment.

## MIL-PRF-63029J

3.5.8 Chapter 4 – Mission Equipment <chapter4>.

3.5.8.1 General. A description of all standard mission equipment that may be utilized with the aircraft shall be provided. Coverage shall include description, controls and function, operating procedures, power sources, and illustrations. Controls, functions, and operating procedures shall be prepared as detailed in 3.5.7.2.2 through 3.5.7.2.5, as applicable. The sections listed below will be included if applicable. Sections shall be sequentially numbered.

3.5.8.2 Section I – Mission avionics <ch4sect1>. Unclassified information regarding mission avionics equipment that is not a part of the standard flight communication, navigation, transponder, or radar equipment shall be provided. It includes electronic equipment such as radio monitoring systems, side looking airborne radar (SLAR), IR devices, and photographic equipment. Detailed information shall be given regarding the photographic equipment including, but not limited to, types of cameras, control stations, camera doors, and capabilities of the equipment. Gun camera equipment shall also be covered. Mission avionics equipment that requires extensive explanation of operating procedures shall be covered in this section or separately. An appendix for mission avionics equipment shall be included only if authorized by the acquiring activity (6.2). Classified information on mission avionics equipment shall be covered in a separate classified supplement to the manual.

3.5.8.3 Section – Armament <ch4sect2>. The description of gunnery, rocket, tow target, control, and computer equipment and their interrelations when installed shall be provided. Armor protection shall be discussed along with the individual item that is being protected. Precautions and safety considerations shall also be included.

3.5.8.3.1 Armament control system. Description and operating instructions for the armament control system shall be provided, if applicable. Also, information such as presentation on the scope or sight, when applicable, shall be included. Warm-up time and preflight, in-flight before landing and after landing checks shall be listed. Checklist format and style shall be in accordance with Appendix C.

3.5.8.3.2 Gunnery equipment. Information shall be included on all guns and turrets, including quantity of ammunition that can be carried for each gun. When describing remote controlled turrets, the manual shall include, but shall not be limited to, the station from which the turret is operated, method of gaining control of the turret, and method of transferring control. All gunnery controls shall be covered, including gun sight and gun heater.

3.5.8.3.3 Rocket equipment. Information shall be provided regarding the firing procedures, description and capability, controls, and types and number of rockets that can be carried. Typical combinations of rockets and firing order shall be covered. Special precautions, if any, shall be listed.

3.5.8.3.4 Missiles. Information shall be provided regarding the firing procedures, description and capability, controls, and types and number of missiles that can be carried. Special precautions, if any, shall be listed.



## MIL-PRF-63029J

3.5.8.3.5 Laser Control System. Description and operating instructions for the laser control system shall be provided, if applicable. Also, information such as presentation on the scope or sight, when applicable, shall be included. Warm-up time and preflight, in-flight before landing and after landing checks shall be listed. Checklist format and style shall be in accordance with Appendix C.

3.5.8.4 Section – Cargo handling <ch4sect3>. Descriptions and procedures for cargo handling systems and equipment to include hoists, winches, and cargo hooks shall be provided.

3.5.8.5 Section – Passive defense <ch4sect4>. Passive defense equipment shall be described, procedures outlined, and controls and precautions listed. Employment methods shall also be discussed.

3.5.8.6 Section – System Payload <ch4sect5>. (Optional) System payload shall be described, as applicable.

3.5.8.7 Additional system coverage <ch4sect additional>. At the acquiring activity's discretion (6.2), additional sections shall be used to describe systems not covered in other sections.

3.5.9 Chapter 5 – Operating Limits and Restrictions <chapter5>.

3.5.9.1 General. All important operating limits and restrictions that shall be observed during ground and flight operations shall be provided. Special emphasis shall be placed on any unusual restrictions which are particularly characteristic of the aircraft. All time limited operations shall include a time limit and the upper and lower boundaries.

3.5.9.2 Section I – General <ch5sect1>. General information on aircraft limits and restrictions, including decals and placards shall be provided. The following statements shall be included:

- a. Purpose. This chapter identifies or refers to all important operating limits and restrictions that shall be observed during ground and flight operations.
- b. General. The operating limitations set forth in this chapter are the direct result of design analysis, tests, and operating experiences. Compliance with these limits shall allow the pilot to safely perform the assigned missions and to derive maximum utility from the aircraft.
- c. Exceeding operational limits. Any time an operational limit is exceeded, an appropriate entry shall be made on DA Form 2408-13-1. The entry shall state what limit or limits were exceeded, range, time beyond limits, and any additional data that would aid maintenance personnel in the maintenance action that may be required.

## MIL-PRF-63029J

d. Minimum crew requirements. The minimum crew required for flight is (fill in proper number). Additional crew members, as required, will be added at the discretion of the commander in accordance with pertinent DA regulations.”

3.5.9.3 Section II – System limits <ch5sect2>. All aircraft system limits not covered elsewhere in this chapter that may restrict operation shall be provided.

3.5.9.3.1 Instrument, interactive display, or display operating ranges and markings. Each instrument, interactive display, or display that indicates an operating limit(s) shall be illustrated and accurately reflect the actual markings/displays on the instrument, interactive display, or display (Figure 16). The information appearing on the illustration depicting markings or displays shall not be repeated in the text or table. The color coded markings/displays or interactive display graphic symbols shall be fully explained. If the instrument, interactive display, or display limits cannot be adequately explained in the space provided for the captions, explanations shall be included under the appropriate paragraph heading. The text shall state or describe all limit ranges, including gaps that may be shown in range markings.

3.5.9.3.2 Propeller limitations. Propeller limitations shall be discussed including, but not limited to, reverse pitch and restricted revolutions per minute (rpm).

3.5.9.3.3 Rotor limitations. For rotary wing aircraft, rotor limitations during both flight and ground operation shall be discussed, covering such points as restricted rpm, autorotational rpm, limitations for startup and shutdown during high winds, and wind gust spread.

3.5.9.3.4 Additional limitations. All system limits and restrictions not described by the instrument markings shall be included. Limits and restrictions that should be observed when operating utility, heating, ventilation, cooling, or rain removal systems shall also be included.

3.5.9.4 Section III – Power limits <ch5sect3>. Power limits shall include engine and drive train and idle limitations. Limitations that must be observed when alternate fuel grades are used shall be included. Acceleration limits and restrictions that apply to the engine shall be covered. Limits shall be expressed in terms of observable indications that are available to the flight crew; e.g., 360°C, 46 lbs, 10 psi. Terms such as military power or takeoff power shall not be used.

3.5.9.5 Section IV – Loading limits <ch5sect4>. Loading limits pertaining to the aircraft shall be discussed in detail.

3.5.9.5.1 Center-of-gravity (CG) limitations. Longitudinal limitations shall be described. Lateral limitations shall be described when specified by the acquiring activity (6.2). Also, a statement similar to the following shall be included:

“CG limits for the aircraft to which this manual applies and appropriate charts for computation of the CG are contained in Chapter 6.”

## MIL-PRF-63029J

3.5.9.5.2 Weight limitations. All minimum/maximum aircraft weight limitations including parking, towing, taxiing, and takeoff and landing from prepared/unprepared fields shall be provided. For aircraft in which weight distribution is a problem (such as minimum fuel to be carried in the wings at various gross weights), coverage of the limitations involved shall be included. References or links shall be made to fuel management in Chapter 2, as necessary.

3.5.9.5.3 Turbulence. Restrictions regarding flying in all levels of turbulence shall be discussed and limitations shall be covered.

3.5.9.5.4 Other limitations. Other types of limitations that affect operations shall be covered, including the following:

- a. Additional restrictions to be observed when carrying stores. For aircraft equipped to carry a variety of external stores, information concerning the stores carried at each station and the maximum lateral unbalanced load that can be carried shall be included.
- b. Limitations as to the weight for external sling loads on rotary wing aircraft and speed restrictions, if any.
- c. Floor loading limits that are to be observed when carrying internal cargo.
- d. Restrictions on jettisoning external stores and sling loads.

3.5.9.6 Section V – Maximum and minimum airspeed limits <ch5sect5>.

3.5.9.6.1 Introduction. Airspeed limitations shall be discussed, including level flight airspeed, diving airspeed, airspeed for various degrees of flap extension, airspeed for various stabilator positions, airspeed for door opening, and airspeeds under various conditions of weight and configuration. For rotary wing aircraft, sideward and rearward airspeed limits and restrictions shall be discussed. Airspeeds shall be expressed as knots indicated airspeed (KIAS), unless otherwise specified by the acquiring activity (6.2).

3.5.9.6.2 Airspeed operating limits chart. This chart shall present operating limits for forward flight at various gross weights, pressure altitudes, free air temperature (FAT), and KIAS (Figure 17).

3.5.9.7 Section VI – Maneuvering limits <ch5sect6>.

3.5.9.7.1 Introduction. Maneuvering flight limitations to include acrobatic flight, if applicable, shall be described. Acceleration limitations shall also be covered, including maximum acceleration with tip tanks and maximum bank angle at high gross weight. Maximum permissible accelerations under various flight conditions at specific gross weights and fuel weights shall be detailed. For aircraft not equipped with G meters, G forces shall be expressed in terms that are recognizable by the pilot, such as airspeed and bank angle. Restrictions on

## MIL-PRF-63029J

control movements shall be listed. Material shall be presented on permissible bank angles, side slip, flight loads and slope operations. Prohibited maneuvers shall be listed as appropriate.

3.5.9.7.2 Flight envelope chart. For aircraft with G meters, plots of load factor versus speed for the full range of gross weight shall be shown. The speeds at which maneuvers are restricted and unrestricted, as a function of load limit factors, shall be presented (Figure 18). When changes in configuration result in variations in airspeed position error, separate airspeed scales shall be shown. Where direct reading Mach meters are provided, charts for both indicated airspeed (IAS) and indicated Mach number (IMN) shall be provided.

3.5.9.8 Section VII – Environmental restrictions <ch5sect7>.

3.5.9.8.1 Introduction. As applicable, altitude, temperature, rain, snow, ice, hail, and oxygen limits shall be provided. Material on maximum wind velocity and gust spread, maximum wind velocity for crosswind operations, wind from the critical azimuth, turbulence, and normal operation shall be included. Operations under wind azimuth direction and wind velocity conditions that should be avoided shall be discussed. Where appropriate, charts shall be used to depict the preceding conditions.

3.5.9.8.2 Flight under instrument meteorological conditions (IMC). The definition of IMC and the criteria for such flights shall be provided. In addition, when applicable, information on when a particular aircraft is qualified for operation in instrument meteorological conditions, and when a certain aircraft is restricted to visual flight conditions shall be included.

3.5.9.9 Additional sections <ch5sect\_additional>. When specified by the acquiring activity, (6.2), additional sections may be used to allow for added limits or restrictions to fit specific aircraft.

3.5.10 Chapter 6 – Weight/balance and loading <chapter6>.

3.5.10.1 Section I – General <ch6sect1>. General statements about the importance of weight and balance calculations shall be provided. In addition, a note that Chapter 6 contains sufficient instructions and data so that an aviator, given the proper data, can compute and combination of weight and balance shall be included. When weight and balance computers/calculators are provided for the aircraft, instructions and examples of their use shall be based on gear down configurations, with supplementary data for gear up conditions (when required). A statement similar to the following statement shall be included:

“Army (insert assigned aircraft designation) is in class (insert class). Additional directives governing weight and balance of class (insert class) aircraft forms and records are contained in AR 95-1.”

## MIL-PRF-63029J

3.5.10.1.1 Aircraft compartment and station diagram. A general description of the aircraft compartments and a supporting diagram shall be provided. The diagram shall show the reference datum line, stations, butt lines, and water lines in inches (Figure 19).

3.5.10.2 Section II – Weight and balance <ch6sect2>. Information necessary for the computation of weight and balance for loading of specific aircraft shall be provided. Instructions for completion of weight and balance forms (DD Form 365 series) shall not be provided in the manual; however, TM 55-1500-342-23 which provides these instructions shall be referenced. Sufficient information shall be provided to permit the flight crew to readily use the data presented in the other sections of this chapter to determine loading arrangements, fuel burn or transfer sequences, ordnance off-load sequences, and other weight and balance procedures to ensure the aircraft remains within weight and balance limits for the entire flight.

3.5.10.3 Section III – Fuel/oil <ch6sect3>.

3.5.10.3.1 Fuel quantity data. Fuel quantity data shall be in chart form (Figure 20). The names of the tanks on the charts shall be identical to the name appearing on the tank selector (a more explanatory title may be carried in parentheses if desired). Any group of tanks or cells that are interconnected to fill and drain shall be treated as a single tank. The chart shall include data on each tank (including droppable and ferry) that is designed for use with the aircraft. Tank volume shall be given in terms of usable fuel rather than total tank volume. Fuel quantities shall be given in gallon regardless of the type of instrumentation. All gallon figures shall be followed by the conversion to pounds. The grid lines within the chart shall be based on fuel weight in pounds of fuel. It shall be stated that the weights are based on a given specific gravity at standard day temperature.

3.5.10.3.2 Oil data. When specified by the acquiring activity (6.2), a statement of usable oil capacity, equivalent in pounds, total moments, and fuselage station number shall be provided. Aircraft that have a large usable oil capacity shall have a tabular listing if oil loading computation is critical. It shall be noted that the weight shall be based on specific gravity at standard day temperature.

3.5.10.4 Section IV – Personnel <ch6sect4>. All essential information and instructions for preparation, loading, and unloading of personnel, including airborne troops shall be provided.

3.5.10.4.1 Personnel compartment and entrances. A general description of the personnel compartment and entrances, including profile and cross-section drawings showing all dimensions, in inches, shall be provided. In addition, a description shall be provided of any critical dimensions which limit full use of the personnel compartment.

3.5.10.4.2 Personnel loading and unloading. Personnel loading and unloading shall include, but shall not be limited to, a checklist and description of steps necessary for loading and unloading troops as follows:

a. Troop seat installation.

## MIL-PRF-63029J

- b. A description and operation of safety belts and harness.
- c. A check of comfort and emergency provisions.
- d. Instructions for troop loading and unloading procedure.

3.5.10.4.3 Personnel weight. When aircraft are operated at critical gross weights, the exact weight of each individual occupant, including the weight of the equipment shall be provided. In addition, if weighing facilities are not available, or if the tactical situation dictates otherwise, loads shall be included and computed as follows:

- a. Combat equipped soldiers – 240 lbs per individual.
- b. Combat equipped paratroopers – 260 lbs per individual.
- c. Litter and patient's weight – 265 lbs per patient.
- d. Crew and passengers with no equipment – compute weight according to each individual's estimate.

3.5.10.4.4 Personnel moments. Personnel moments charts for personnel in any position shall be provided (Figure 21).

3.5.10.5 Section V – Mission equipment <ch6sect5>. Loading data charts for mission equipment shall provide a tabular listing containing the quantity, weight and moment of each load item up to the maximum quantity for which provisions are available. Only items of load shall be listed. Items that are part of the basic weight shall not be part of this listing. Data shall be provided for all applicable mission system loads including, but not limited to, armament, avionics, sling, hoist, and litters. Listings shall provide weights and moments of required pylons and launchers. Tabular listing of rockets shall be inclusive for maximum capacity of launchers. Since rockets vary in weight by type, separate listings shall be required (Figure 22).

3.5.10.6 Section VI – Cargo loading <ch6sect6>. Detailed information on cargo loading shall be provided, as applicable.

3.5.10.6.1 Description and illustrations. A general description of cargo compartments and entrances, including profile and cross-section drawings showing all dimensions (in inches) shall be provided. Also, descriptions of critical dimensions that limit full use of cargo compartments shall be included.

- a. A plan view showing dimensions of cargo floor, designation, location, and strength of tie-down fittings, and diagram and limitations on use of fittings, including the desirable cone of action when using fittings, shall be provided. Also, a plan view of cargo floor showing

## MIL-PRF-63029J

variations in floor strength and weight concentration limitations in various areas shall be included, as applicable.

- b. A suitable view of litter provisions showing location shall be presented.
- c. A general description of, and operating instructions for, aerial delivery systems shall be included, when applicable.
- d. A list and description of all cargo loading aids, unloading aids, cargo securing equipment (including, but not limited to, ramps, hoists, winching provisions, and tie-downs), and stowage provisions shall be provided.

3.5.10.6.2 Equipment loading and unloading. Procedures and a checklist for loading and unloading vehicles and equipment shall be provided, as follows:

- a. Assembly of equipment needed for loading.
- b. Preparation of cargo compartment and floor and installation of fittings.
- c. Preparation of the aerial delivery system.
- d. Including, but not limited to, operation of cargo doors, ramps, load assist devices, and aircraft support jacks, including installation and operation, as applicable. Instructions for checking landing gear shall be included, when appropriate.
- e. Assembly and checking of unloading aids and releasing of cargo tie-down devices.

3.5.10.6.3 Preparation of general cargo. Pre-loading information shall be presented as follows:

- a. Instructions that loading personnel should assemble prior to loading data, such as weights, dimensions, CG locations, and contact areas of equipment for use in positioning the load shall be included.
- b. Reference or a link shall be made to the weight and balance computations in Section II, and the balance computer, if furnished, for the computation of final load positions in the aircraft.

3.5.10.6.4 Loading, securing, and unloading cargo. General methods of loading, safe lashing, and unloading of cargo, vehicles, and equipment shall be provided. Rigging of cargo for aerial delivery shall be included, when applicable. The information shall be detailed enough to acquaint service personnel with the factors involved in properly loading, securing loads, and unloading the aircraft.

3.5.10.6.5 Cargo center-of-gravity. A chart shall be provided (Figure 23) showing approximate allowable cargo CGs versus known weights which may be used for planning purposes for various cargo loads. The chart shall be based on a range of aircraft basic weights

## MIL-PRF-63029J

and center of gravity locations to allow for anticipated variations in these values. The chart shall state that these data are for planning purposes only, that the results are approximate, and final loading must be checked for the particular aircraft using weight and balance computations and the balance computer, if furnished.

3.5.10.6.6 Loading procedure. A checklist of the actions required from the time the aircraft is prepared for loading until it is ready for flight shall be provided. It shall include instructions and notes on loading equipment into the aircraft, checking items with CG markings and items 10 feet or longer and placing them in position, determining the amount of shoring required for flight conditions, and general instructions for loading and lashing miscellaneous cargo. Reference shall be made to the appropriate regulations regarding handling of hazardous equipment.

3.5.10.6.7 Securing loads. The following items shall be described.

- a. Approved restraint criteria including fore, aft, sideward and vertical restraints.
- b. Detailed tie-down instructions shall be provided only for equipment or cargo that is unique to a specific aircraft.

3.5.10.6.8 Unloading procedures. Procedures for unloading the aircraft and stowing associated equipment shall be provided.

3.5.10.7 Section VII – Center-of-gravity <ch6sect7>. Longitudinal CG limitations shall be included, and lateral CG limits shall be shown as specified by the acquiring activity (6.2).

- a. Where possible, the gross weight and CG limitations of the aircraft shall appear on a single chart. However, additional charts may be used if necessary to adequately portray the various configurations of the aircraft. All charts shall be in the style and format as shown in Figure 24.
- b. Explanatory text shall explain the purpose and components of the charts; illustrate the use of the charts; emphasize that charts are designed to illustrate degree of risk involved at various weights and CGs; and establish limitations.
- c. The chart shall be based on gross weight that is defined as the total weight of the aircraft and its contents. It shall include, but not limited to, operating weight plus fuel, cargo, ammunition, missiles, and external auxiliary fuel tanks. The gross weight in pounds shall be shown on the left side of the chart, and shall range from the aircraft's minimum operating weight to maximum gross weight allowable.
- d. At least one example to illustrate the application of the chart shall be included.

3.5.10.8 Additional sections <ch6sect additional>. When specified by the acquiring activity (6.2), additional sections may be used.



## MIL-PRF-63029J

3.5.11 Chapter 7 – Performance Data <chapter7>.

3.5.11.1 General. All the performance data charts required for the completion of preflight and in-flight mission planning shall be provided. The data presented shall cover the maximum range of conditions and performances for which the aircraft is qualified. Explanatory text applicable to the use of data presented shall be included for each model of aircraft. Performance data charts shall appear in the initial issue of the manual.

a. Information contained on the charts shall be based on, and shall be consistent with, the recommended operating procedures and techniques set forth elsewhere in the manual. Each section shall include an explanation of all applicable charts and a synopsis of pertinent terms used with each chart. The Contractor shall provide a substantiating data report describing all data and methodology used to produce each performance/operating limitation chart published in the Operator's Manual. This report shall in general follow the format of ADS-40, Air Vehicle Flight Performance Description for rotary wing air vehicles and MIL-C-005011B, Standard Aircraft Characteristics and Performance, Piloted Aircraft (Fixed Wing) and MIL-STD-3013 Glossary of Definitions, Ground Rules and Mission Profiles to Define Air Vehicle Performance Capability for Fixed Wing Air Vehicles. Each report shall include a description of the static flight performance model, input description, and input database developed to generate the charts. Wherever possible, the performance model shall be correlated with flight test data. Additionally, the analytical methods and supporting data shall be described for each type of performance chart presented in the TM. The substantiating data report shall be reviewed by the airworthiness authority during the TM approval process.

b. In addition to the draft TM, the acquiring activity may require submission of an aerodynamic report illustrating the derivation of the data entered on the charts included in the TM. The report should include an analysis leading to the establishment of lift and drag values used in the calculations, aircraft efficiency and compressibility correction factors, methods of computing power or thrust required and available, a discussion of engine installation losses to include inlet and exhaust loss, power extraction, bleed air offtakes, duct loss, propeller efficiency, transmission efficiency, and adequate references to appropriate wind tunnel or flight test data.

3.5.11.1.1 Data basis. Unless otherwise specified by the acquiring activity (6.2), the preparation of performance data charts shall be derived from flight test reports, when available. Exceptions to this may be authorized by the acquiring activity (6.2) for new aircraft, provided adequate flight tests have been completed for the prototype. However, for these exceptions, an evaluation of all changes that affect performance shall be obtained by additional flight tests. The basis for data presented shall be clearly defined at the bottom of each chart to include data type and source data document. Army test reports shall be used when available. When flight test reports are not available, referenced estimates shall be clearly identified as such. Conservative estimates shall be used until verified by flight test data. Data that are not based strictly on the particular aircraft shall be explained in detail.

## MIL-PRF-63029J

3.5.11.1.2 Identification. Each chart shall be marked in the following manner:

- a. Titles shall be centered above the chart. The name of each chart shall define the type of information to be obtained from that particular chart.
- b. Condition headings (E.3.2.5.2) shall be centered below the title and, when required, shall contain the following types of information, when applicable:

- (1) Pressure altitude.
- (2) Situation to which chart applies (takeoff, landing, sling load takeoff).
- (3) Conditions of auxiliary equipment.
- (4) Configuration.
- (5) Wing flap position.
- (6) Rotor or prop rpm.
- (7) Engine rpm.
- (8) Fuel type.
- (9) Hovering condition (in ground effect (IGE) or out of ground effect (OGE)).
- (10) Power requirements.
- (11) Runway conditions.
- (12) Wind conditions.
- (13) Gear up/down.
- (14) Power required.
- (15) Ambient temperature

- c. Titles of figures shall match the title shown at the top of each chart.

3.5.11.1.3 Factors affecting data. Conditions that affect the data but are not presented as variables on any specific chart shall be listed as “Conditions” under the title of the chart. An explanation of these factors shall be included in the text that describes that chart.

## MIL-PRF-63029J

3.5.11.1.4 Configuration. Unless otherwise specified by the acquiring activity (6.2), the baseline configuration for all presented data shall be the most probable combat configuration. This baseline configuration shall be labeled and presented as a condition on applicable charts. The baseline configuration shall be completely defined in the “Drag” section. Where inherent configuration variations exist (including, but not limited to, antenna variations, IR suppressers, and engine inlet configurations), the data shall be based on the most conservative configuration combination (highest drag, lowest power/thrust available, highest fuel consumption, etc.). The effects of altering these items shall be discussed in each section, as applicable.

3.5.11.1.5 Fuel. All charts shall be based on the primary fuel for the engine/engines installed unless additional charts are required by the acquiring activity (6.2) for alternate fuels.

3.5.11.1.6 Atmospheric conditions. Where data are presented incrementally, they shall be presented to the next increment beyond the range of probable operating atmospheric conditions as found in MIL-HDBK-310, for guidance only, to permit interpolation. Unless otherwise specified by the acquiring activity (6.2), standard day, standard conditions, standard temperature, or density altitude shall not be mentioned or presented. All atmospheric data and formulas including pressure (P) and pressure altitude ( $H_p$ ) shall be based on the USAF 1976 US Standard atmosphere as adapted by the ICAO. The following formulas for converting pressure altitude ( $H_p$ ) to static air pressure (P), and vice versa, shall be used:

$$P \text{ (in. Hg)} = 29.92125(1 - H_p/145,442.1)^{5.255876}$$

$$H_p \text{ (ft.)} = 145,442.1(1 - P/29.92125)^{1.902632}$$

3.5.11.1.7 Allowances. Allowances shall be made for all installation losses and a complete analysis of such allowances shall be included in the performance data substantiation report. The following allowances shall be included. An increased allowance of five percent shall be made for fuel consumption data only when data are based on estimates; however, this shall not be stated in the TM.

3.5.11.1.8 Limitations and restrictions. Applicable operating limits shall be shown. Restricted operating regions shall be depicted by shaded areas. Data shall be extended to the next normal increment beyond operating limits to aid interpolation. Such data shall be represented by dotted lines. Note: maximum gross weight is an operating limit.

3.5.11.1.9 Definitions. Definition of terms used including, but not limited to, takeoff speed, takeoff distance, and rotation speed shall be included in abbreviations and terms (3.5.15).

3.5.11.1.10 Rotary wing performance data. A list of the required performance data charts and tables shall be provided by the developer to the acquiring activity (6.2) before the charts are made so that there is concurrence on what will be included. At a minimum, the following performance data charts shall be required (current examples of each category are provided in the referenced figures):

## MIL-PRF-63029J

- a. Fuel flow (Figure 25).
- b. Maximum torque available (insert condition/time) (Figure 26).
- c. Hover (Figure 27).
- d. Takeoff (Figure 28).
- e. Drag (Figure 29).
- f. Cruise (Figure 30).
- g. Climb-descent (Figure 31).
- h. Airspeed calibration (Figures 32 and 33).

As specified by the acquiring activity (6.2), additional charts peculiar to certain aircraft, such as multi-engine, shall be included. These charts, if required, shall completely define the operation or restrictions of the aircraft.

3.5.11.1.11 Fixed wing performance data. Unless otherwise specified by the acquiring activity (6.2), the following performance data shall be presented for fixed wing aircraft:

- a. Crosswinds – takeoff and landing (Figure 35).
- b. Idle fuel flow (Figure 25).
- c. Torque available for takeoff (Figure 36).
- d. Takeoff – normal (Figure 37).
- e. Normal rotation/takeoff airspeed (Figure 38).
- f. Acceleration check distance (Figure 39).
- g. Accelerate-stop distance (Figure 40).
- h. Accelerate after lift-off (Figure 41).
- i. Minimum single engine control airspeed (Figure 42) (flaps down and up, if applicable).
- j. Single engine climb (Figure 43).
- k. Cruise climb (Figure 44).

## MIL-PRF-63029J

- l. Drag (Figure 29).
- m. Cruise (Figure 45).
- n. Climb/descent (Figure 46).
- o. Approach speed (Figure 47).
- p. Landing (Figure 48).
- q. Airspeed calibration (Figures 32 and 33).

Additional charts peculiar to certain aircraft, such as multi-engine, shall be included as specified by the acquiring activity (6.2). These charts, if required, shall completely define the operation or restrictions of the aircraft.

3.5.11.2 Section I – Introduction <ch7sect1>. An explanation of the performance data including the purpose, scope, limits, uses, and conditions shall be provided.

3.5.11.2.1 Purpose. The following paragraphs shall be included:

“The purpose of this chapter is to provide the best available performance data for the (insert assigned aircraft designation). Regular use of this information will allow you to receive maximum safe use of the aircraft. Although maximum performance is not always required, regular use of this chapter is recommended for the following reasons:

- a. Knowledge of performance margins will allow you to make better decisions when unexpected conditions or alternate missions are encountered.
- b. Situations requiring maximum performance will be more readily recognized.
- c. Familiarity with the data will allow performance to be computed more easily and quickly.
- d. Experience will be gained in accurately estimating the effects of conditions for which data are not presented.

The information is primarily intended for mission planning and is most useful when planning operations in unfamiliar areas or at extreme conditions. The data may also be used in flight, to establish unit or area Standard Operating Procedures, including pilot aid cards, and to inform ground commanders of performance/risk tradeoffs.”

## MIL-PRF-63029J

3.5.11.2.2 General. This paragraph shall contain a statement similar to the following:

“The data presented cover the maximum range of conditions and performance that can reasonably be expected. In each area of performance, the effects of altitude, temperature, gross weight, and other parameters relating to that phase of flight are presented. In addition to the presented data, judgment and experience will be necessary to accurately determine performance under a given set of circumstances. The conditions for the data are listed under the title of each chart. The effects of different condition are discussed in the text accompanying each phase of performance. Where practical, data are presented at conservative conditions. However, no general conservatism has been applied.

**WARNING**

Exceeding operating limits can cause permanent damage to critical components. Overlimit operation can decrease performance, cause immediate failure, or failure on a subsequent flight, which may result in injury or death to personnel.

Applicable limits are shown on the charts. Performance generally deteriorates rapidly beyond limits. If limits are exceeded, minimize the amount and time. Enter the maximum value and time beyond limits on DA Form 2408-13-1 so proper maintenance action can be taken. Exceeding operating limits can cause permanent damage to critical components. Overlimit operations can decrease performance, cause immediate failure, or failure on a subsequent flight.”

3.5.11.2.3 Use of charts. This paragraph shall contain a sample problem typical of a normal mission accomplished by the aircraft. The sample shall be included on or precede the first chart. Additional examples shall be prepared as required for other charts within a section. When possible, actual chart values shall be used throughout the problem. Data for the problem in which derivation may not be entirely clear shall be explained. Additional discussion, sample problems, or illustrations may be used throughout the chapter to clarify the usage of charts.

The TM shall point out that the use of a straight edge (ruler or page edge) and a hard fine point pencil is recommended to avoid cumulative errors. In addition to the primary use, other uses of each chart are explained in the text accompanying each set of performance charts. An example of an auxiliary use of the charts shall be shown by noting that although the hover chart is primarily arranged to find torque required, maximum skid/wheel height or maximum gross weight can also be found. The TM shall note that in general, any single variable can be found if all other variables are known. Also, the tradeoffs between two variables can be found.

3.5.11.2.4 Data basis. This paragraph shall contain a statement similar to the following statements and definitions:

## MIL-PRF-63029J

“The source of data used is indicated at the bottom of each performance chart under “Data Basis”. The applicable report and date of the data are also given. The data provided generally are based on one of the following categories.

- a. Flight test data are obtained by flight tests of the aircraft at precisely known conditions using sensitive calibrated instruments.
- b. Calculated data are data based on tests, but not on flight tests of the complete aircraft.
- c. Estimated data are data based on estimates using aerodynamic theory or other means not verified by flight testing.”

3.5.11.2.5 Specific conditions. This paragraph shall contain a statement similar to the following:

“The data presented are accurate only for specific conditions listed under the title of each chart. Variables for which data are not presented, but which may affect that phase of performance, are discussed in the text. Where data are available or reasonable estimates can be made, the amount that each variable affects performance shall be given.”

3.5.11.2.6 General conditions. General conditions, in addition to specific conditions listed on each chart, shall be included. Examples of general conditions which might affect performance of the aircraft shall include, but shall not be limited to, rigging, pilot technique, sideslip, aircraft variation, engine variation, and instrument variation. Information shall be included which defines what effect the general conditions listed shall have on the performance data of the aircraft.

3.5.11.2.7 Performance discrepancies. A statement similar to the following shall be included in the TM:

“Regular use of this chapter will also allow monitoring of instruments and other aircraft systems for malfunctions, by comparing actual performance with planned performance. Knowledge will also be gained concerning the effects of variables for which data are not provided, thereby increasing the accuracy of performance predictions.”

3.5.11.3 Section II and subsequent sections <ch7sectDataCharts>. A separate section shall be created for each chart listed in 3.5.11.1.10 or 3.5.11.1.11, as applicable. The sections shall be titled using the applicable performance data chart title. The sample charts provided in this specification are examples only. In addition to the chart itself, each section shall contain, as a minimum, the following:

- a. Description. A description of the performance data including those parameters obtainable from the chart and information relative to any peculiarity of data presented shall be provided.

## MIL-PRF-63029J

b. Use of charts. Reference shall be made to examples used on each chart. Additional use of charts may be included when approved by the acquiring activity (6.2). Reference shall be made to related charts that may be used in conjunction with the chart and all information relative to peculiarities of data presented on the chart.

c. Conditions. Each condition that has a direct or indirect effect on the chart data presented shall be discussed, explaining the effect it may have on the aircraft.

3.5.11.3.1 Rotary wing chart content. Performance data charts for rotary wing aircraft shall conform to the requirements detailed in the following paragraphs:

3.5.11.3.1.1 Fuel flow chart. The fuel flow chart (Figure 25) shall show fuel flow at both the engine idle position and at normal rotor speed with flat pitch. The chart shall also present fuel flow conditions when the engine is operational at different configurations, e.g. bleed air On/Off. Pressure altitude and FAT shall be used as the criteria for fuel flow computations. Reference shall be made to other charts that present fuel flow data at cruise conditions. Fuel flow data shall be based on the primary fuel type. Information shall be included in the supporting text to define additional pertinent information which may affect fuel flow. All data shall be based on normal operating engine rpm.

3.5.11.3.1.2 Maximum torque available chart. The charts for maximum torque available (Figure 26) shall show the effects of altitude and temperature on the maximum torque available and shall take into consideration calibration factors used to correct for known errors in torque indicating systems. Separate charts shall be provided for each applicable set of time limited torque available data. For example, separate charts shall be provided for intermediate (30 minute) and one engine inoperative contingency (10 minute) torque available data. Information shall be provided to allow the operator to correct the data presented on the charts to account for variations in torque available due to operation of IR suppressers, systems requiring bleed air, or other similar operating conditions. Information shall also be provided to allow the operator to correct the data presented to account for known variations in the torque available of the individual engines installed in the aircraft compared to the standard or specification engines depicted by the charts.

3.5.11.3.1.3 Hover chart. The hover chart (Figure 27) shall present the torque required to hover at given conditions of skid/wheel height, gross weight, temperature and altitude. Basic IGE hover data shall be based on hovering over a level surface. If IGE hover data are presented for other than level surfaces, information shall be included in the supporting text or on the charts. Compressibility effects on hover power required should be Included and one method of adding a temperature versus delta torque required table is shown on Figure 27. Also, Aircraft limitations may be presented on the Hover chart or additional charts in the Hover section to include marginal areas of performance. When unsafe performance areas could be encountered, the full range of precautionary data shall be presented and safe limits presented to better clarify the use of the data.



## MIL-PRF-63029J

3.5.11.3.1.4 Critical data chart. Critical wind azimuth and velocities at varying gross weights, pressures altitudes, and FAT during hover and low speed flight shall be presented as required. A separate chart may be used.

3.5.11.3.1.5 Takeoff chart. The takeoff chart shall consist of all takeoff data required to clear various obstacle heights and shall be based on all the parameters shown on Figure 28. All approved techniques such as level acceleration, coordinated climb, and sling load techniques shall be covered on additional charts as required by the acquiring activity (6.2). The primary parameters used for takeoff performance shall be maximum hovering height capability, FAT, gross weight, and maximum torque available. Additional performance charts shall be referenced when required. Takeoff limits shall be stated and indicated on all charts. All takeoff conditions shall be based on calm winds, level hard surfaces, normal rotor/engine speeds, and optimum torque available.

3.5.11.3.1.6 Drag chart. The baseline configuration for drag (Figure 29) shall be completely defined. Inherent or basic equipment variations, existing or anticipated, and any external stores included in the baseline configuration shall be provided. Data shall be prepared to show each drag item and the drag area change in square feet based on additional engine torque or horsepower required. These data shall be prepared in tabular form or shall be conveyed in a manner more suitable for interactive viewing. Negative drag increments from baseline configurations shall be permissible. The drag data shall fall into one of these major categories: (1) inherent or basic aircraft modifications or basic equipment changes; (2) external stores and store combinations; (3) crew alterable configurations; and (4) for helicopters with sling capability, drag of various standard sling loads. A procedure shall be provided for estimating drag of sling loads for which data are not provided. Information to determine the change in maximum range or long range cruise to chart the airspeed with drag variations shall be provided. A supplementary graph on the cruise chart depicting torque/horsepower change for drag change shall be provided. It shall cover the airspeed range from minimum power to limit airspeed. It shall also cover a drag range to one-half the basic aircraft drag or the largest drag increment combination, whichever is larger. One or two alternate total configurations shall be depicted on these sub-graphs using special line coding with approval of the acquiring activity (6.2). If alternate configurations are depicted, they shall be completely defined using separate charts, as applicable.

3.5.11.3.1.7 Cruise chart. Cruise charts (Figure 30) shall present torque requirements for level flight at various airspeeds, gross weights, pressure altitudes, and FAT. The particular altitudes and temperatures at which cruise data are to be presented shall be specified by the acquiring activity (6.2). Indicated airspeeds for all airspeed systems used on the aircraft referenced shall be shown on the charts with the exception of aircraft with cockpit displays which provide calibrated airspeed as the primary airspeed display. Fuel flow shall be shown in such a manner as to allow determination of fuel flow as a function of torque required. Torque available may be shown for maximum torque and continuous bleed air On/Off. When torque available is greater than the torque limit only, the torque limit shall be shown. Velocity never exceeded ( $V_{ne}$ ) shall be shown on each chart, as appropriate. Airspeeds for maximum range, endurance, and rate of climb shall be included on each chart. This information shall be

## MIL-PRF-63029J

presented for each engine when performance data pertain to multi-engine aircraft. Maximum performance, precautionary, and limits data shall be shown on each chart and explained in the text. Other performance data charts related to the cruise charts shall be referenced. All cruise data shall be based on normal operational rotor and engine speed, on drag area changes, true airspeed, pressure altitude, and FAT. A drag area change table showing the change due to each possible configuration change shall be included.

3.5.11.3.1.8 Climb-descent chart. The climb-descent chart (Figure 31) shall show the torque required in excess of that needed for level flight to obtain the desired rate of climb. The torque decrease for a desired rate of descent shall also be shown. Desired rate of climb or descent and gross weight shall be used to compute the torque change required.

3.5.11.3.1.9 Airspeed calibration chart. An airspeed calibration chart (Figure 32, Figure 33 and Figure 34), which defines the relationship between the pilot's indicated and calibrated airspeed for level flight, climb, and descent, shall be provided. Instructions and examples shall be provided to show the operator how to determine the level flight indicated airspeed value which corresponds to known indicated airspeeds in climb and descent. Instructions and examples for determining calibrated airspeeds corresponding to known indicated airspeed shall also be provided. Altimeter correction charts that provide position error correction versus indicated airspeed shall be provided for all normal and emergency altimeter systems. Data shall be provided for all applicable flap settings or other variations in configuration. A temperature conversion/correction chart that provides true FAT as a function of true airspeed and indicated temperature shall also be provided for aircraft capable of significant airspeeds. For those aircraft whose air data system position errors are insignificant, calibration data for airspeed, altitude, and temperature shall be omitted, with approval of the acquiring activity (6.2).

3.5.11.3.1.10 Optimum cruise. When requested by the acquiring activity (6.2), data shall be provided to determine the altitude for maximum range and maximum endurance as a function of gross weight and ambient temperature. Information shall also be provided for optimum rotor/propeller rpm for maximum range and endurance. Where optimum rpm is different from that presented for the (normal) cruise data, information shall be provided to correct fuel flow for the different rpms. Optimum cruise speed (maximum range or endurance) presented on the cruise chart shall be referenced and used. Airspeed and power schedules for climb and descent to maximize total range or endurance shall be described. A means shall be provided for estimating ambient temperature at optimum altitude. Also, a means shall be provided for comparing the effects of varying winds with altitude with the change in aircraft performance with altitude. Data shall cover the range of gross weights and ambient temperatures presented on the cruise charts, and the limits of altitude on the cruise charts, if required. If corrections to optimum altitude for configuration variations are significant and capable of being done, this information shall be provided.

3.5.11.3.2 Fixed wing chart content. Performance data charts for fixed wing aircraft shall conform to the requirements in the following paragraphs.

## MIL-PRF-63029J

3.5.11.3.2.1 Crosswind chart. The crosswind chart (Figure 35) shall show the takeoff or landing conditions under which a takeoff or landing is or is not recommended. Various wind velocities, runway wind angle, and rotation or touchdown airspeeds shall be shown. Additional charts to obtain required information shall be referenced. When more than one configuration is possible for the applicable aircraft, the differences shall be indicated and the charts adjusted appropriately or separate charts may be provided for each configuration.

3.5.11.3.2.2 Idle fuel flow chart. The idle fuel flow chart (Figure 25) shall show idle fuel flow pounds per hour at the airframe idle throttle position at various altitudes and ambient air temperatures. Additional charts, when applicable, depicting idle fuel flow at various idle conditions shall be included. Differences between idle fuel flow with bleed air On or Off and similar conditions shall also be shown when applicable. The type of fuel used in computation shall be shown in the subheading of this chart.

3.5.11.3.2.3 Torque available for takeoff chart. This chart (Figure 36) shall show the torque/power setting/rpm available for takeoff, per engine for multi-engine aircraft, at various ambient air temperatures and altitudes. Maximum torque limits shall be shown when applicable. The standards for which the chart was compiled shall be shown in the heading and defined in the supporting text. Allowable tolerances for available torque shall be stated when applicable.

3.5.11.3.2.4 Takeoff chart. The takeoff chart (Figure 37) shall show the ground roll distance and total takeoff distance required to clear different obstacle heights at various temperatures, altitudes, and aircraft gross weights. Wind conditions, aircraft configuration, power requirements, runway surface conditions, and other applicable information shall be given in the subheading and explained in the text. Additional charts required to obtain information shall be referenced. Each approved takeoff technique shall be covered on separate charts.

3.5.11.3.2.5 Rotation/takeoff airspeed chart. The chart (Figure 38) shall show the recommended normal rotation and takeoff airspeeds for the aircraft at various gross weights. Flap settings and other applicable information, as required by the acquiring activity (6.2), shall be given in the subheading or explained in the text. Each approved takeoff technique shall be covered on separate charts.

3.5.11.3.2.6 Acceleration check distance chart. This chart (Figure 39) shall show the relationship between indicated airspeed and ground roll distance during takeoff. The actual indicated airspeed required at any distance traveled along the takeoff airspeeds for various aircraft gross weights and the required ground roll distances for the aircraft shall be provided.

3.5.11.3.2.7 Accelerate-stop distance chart. The accelerate-stop distance chart (Figure 40) shall show the actual distance required to begin takeoff, accelerate to rotation speed, abort the takeoff, and bring the aircraft to a stop. Variables shall include ambient air temperature, pressure altitude, runway conditions, and gross weight.

## MIL-PRF-63029J

3.5.11.3.2.8 Accelerate after takeoff chart. The accelerate after takeoff chart (Figure 41) shall show the actual distance required to clear an obstacle after takeoff. Parameters shall include FAT, pressure altitude, takeoff weight, and velocity.

3.5.11.3.2.9 Minimum single engine control airspeed chart. The minimum single engine control airspeed chart (Figure 42) is applicable to multi-engine aircraft and shall show the minimum controllable airspeed ( $V_{mc}$ ), with parameters of FAT, pressure altitude, and gross weight, following engine failure during takeoff. The chart shall be based on the operating engine's capability to produce full takeoff power. The primary use of the chart shall be to provide  $V_{mc}$  at takeoff, not to provide single engine rate of climb information. All applicable limits shall be shown and explained in the text. Conditions such as flap setting, landing gear position, etc. shall be included in the subheading or explained in the text. The effect of engine failure on takeoff, climb, and cruising performance, the effect of wind-milling and feathered propellers on aircraft drag, and other adverse factors shall be described.

3.5.11.3.2.10 Single engine climb chart. This chart (Figure 43) shall present single engine airspeeds and rate of climb data for various temperatures, altitudes, and gross weights. Single engine rate of climb shall be based on takeoff airspeeds to include gear-up and gear-down configurations. When alternate aircraft configurations change the validity of information being presented, additional charts shall be prepared with an explanation of the alternate configuration provided in the subheading and within the text when necessary. Information indirectly obtained from the chart that would help in the determination of the best course of action to be taken shall also be included in the text. Reference shall be made to other charts related to single engine operations.

3.5.11.3.2.11 Cruise climb chart. The cruise climb chart (Figure 44) shall be used to find the time, fuel, and distance required to climb. Parameters shall include initial and final FAT, initial and final pressure altitude, and initial gross weight.

3.5.11.3.2.12 Drag chart. The drag chart (Figure 29) shall show additional shaft horsepower required at various airspeeds, altitudes, and temperatures due to drag increases caused by changes in external configuration. Additional shaft horsepower shall be given per engine for multi-engine aircraft. Charts used in connection with the drag chart shall be referenced in the text. Tabular data presenting each drag item and the drag area change in square feet shall be included in the text.

3.5.11.3.2.13 Cruise chart. The cruise chart (Figure 45) shall show the obtainable airspeed, required engine shaft horsepower, engine torque pressure, shaft horsepower increase required due to increases in drag, fuel flow and optimum propeller rpm for maximum range during cruise flight at various aircraft gross weights, altitudes, and temperatures. The particular altitudes, configurations, and temperatures at which cruise data are to be presented shall be specified by the acquiring activity (6.2). This information shall be presented for each engine when performance data pertain to multi-engine aircraft. When fuel flow variations exist due to alternate engine operations, fuel flow for each alternate condition shall be shown. Single engine data shall be placed on the same charts as multi-engine data only when approved by

## MIL-PRF-63029J

the acquiring activity (6.2). Maximum performance, precautionary, and limits data shall be shown on each chart and explained in the text. Indicated and true airspeed for each altitude shall be shown. When an altitude limitation prevents safe single engine cruise for multi-engine aircraft, the single engine graph shall be omitted. Additional charts related to cruise performance shall be referenced in the text.

3.5.11.3.2.14 Climb-descent chart. The climb-descent chart (Figure 46) shall show changes in torque and horsepower required to obtain a desired rate of climb or descent at a known gross weight and propeller rpm. For maximum rate of climb information, reference shall be made to the cruise charts. If the aircraft is other than baseline configuration, an increase in horsepower due to drag shall be computed from the drag chart and added to the horsepower required per engine. Charts used in connection with the climb-descent charts shall be referenced in the text and in the single engine climb chart.

3.5.11.3.2.15 Approach speed chart. The approach speed chart (Figure 47) shall present the recommended airspeeds during approach to landing for the full range of gross weights and flap settings for the aircraft. The chart shall be valid for all aircraft configurations, unless otherwise specified by the acquiring activity (6.2). Charts used in connection with the approach speed chart shall be referenced in the text.

3.5.11.3.2.16 Landing chart. The landing chart (Figure 48) shall show the total ground roll distance for landing with no reverse thrust at known gross weight, pressure altitude, and ambient air temperature. Landing distance shall be based on touching down at the approach speed obtained from the approach speed chart, full braking with 0 degrees, and normal landing flap settings. The correct approach speed is obtained from the approach speed chart. Landing performance shall be based on a dry, level, hard surface runway and calm wind conditions. This chart shall be valid for all stores configurations unless otherwise specified by the acquiring activity (6.2). The chart used in computing landing distances shall be described in the text.

3.5.11.3.2.17 Airspeed calibration chart. An airspeed calibration chart (Figure 32, Figure 33 and Figure 34) that defines the relationship between the pilot's indicated and calibrated airspeed for level flight, climb, and descent shall be provided. Instructions and examples shall be provided to show the operator how to determine the level flight indicated airspeed value that corresponds to known indicated airspeeds in climb and descent. Instructions and examples for determining calibrated airspeeds corresponding to known indicated airspeed shall also be provided. Altimeter correction charts that provide position error correction versus indicated airspeed shall be provided for all normal and emergency altimeter systems. Data shall be provided for all applicable flap settings or other variations in configuration. A temperature conversion/correction chart that provides true FAT as a function of true airspeed and indicated temperature shall also be provided. For those aircraft whose air data system position errors are insignificant, airspeed, altitude, and temperature calibration data shall be omitted, with approval of the acquiring activity (6.2).

## MIL-PRF-63029J

3.5.11.3.2.18 Optimum cruise. When requested by the acquiring activity (6.2), data shall be provided to determine the altitude for maximum range and maximum endurance as a function of gross weight and ambient temperature. Information shall also be provided for optimum rotor/propeller rpm for maximum range and endurance. Where optimum rpm is different from that presented for the (normal) cruise data, information shall be provided to correct fuel flow for the different rpm. Optimum cruise speed (maximum range or endurance) presented on the cruise chart shall be referenced and used. Airspeed and power schedules for climb and descent to maximize total range or endurance shall be described. A means shall be provided for estimating ambient temperature at optimum altitude. Also, a means shall be provided for comparing the effects of varying winds with altitude with the change in aircraft performance with altitude. Data shall cover the range of gross weights and ambient temperatures presented on the cruise charts, and the limits of altitude on the cruise charts, if required. If corrections to optimum altitude for configuration variations are significant and capable of being done, this information shall be provided. When requested by the acquiring activity (6.2), the impact of headwinds and tailwinds on optimum cruise shall be provided.

3.5.12 Chapter 8 – Normal procedures <chapter8>.

3.5.12.1 General. Procedures (amplified checklists) from the time a flight is planned until the flight is completed and the aircraft is properly parked and secured shall be provided. The checklists shall include all steps necessary to ensure safe flight under normal, night, and instrument conditions. Only the duties of the minimum crew necessary for the actual operation of the aircraft shall be included. Instructions for the operation of utility, avionic, mission equipment and controls are contained in Chapters 2, 3, and 4 and shall be included in this chapter only if neglect would affect safety or efficiency of the flight or cause damage to the equipment. (This does not preclude the inclusion of utility equipment checklists in chapters to which they pertain.) Only unique feel, characteristics, and reaction of the aircraft during the various specified phases of operation, and the techniques or procedures used for operating the aircraft shall be described in detail. All precautions to be observed during the various operations shall be covered. Procedures for operation under all adverse environmental conditions shall be described. Instrument flight procedures shall be integrated with normal procedures as much as possible. For aircraft where no unique or abnormal techniques apply, reference shall be made to appropriate flight training publications.

3.5.12.2 Section I – Crew duties <ch8sect1>. Unique crew responsibilities that result from the specific characteristics of the aircraft shall be described. When applicable, a description of mission planning shall also be included.

3.5.12.3 Section II – Operating procedures and maneuvers <ch8sect2>. Normal procedures including all steps necessary to ensure safe and efficient operation of the aircraft from the time preflight begins until the flight is completed and the aircraft is parked and secured shall be provided. Where applicable, performance charts provided in Chapter 7 that are required to carry out specific flight procedures or maneuvers shall be referenced or linked as necessary.

## MIL-PRF-63029J

3.5.12.3.1 Procedures. Procedural steps shall be written so that crewmembers shall not be required to retrace steps. Insofar as possible, checks shall be grouped to keep control manipulation and ground operating time at a minimum. Phases shall be added or deleted to provide for special aircraft or special situations. However, the interpretation of the period of operation encompassed by a given phase shall be identical in all operators' manuals. In the checklists, the condition and response of a procedural step shall be separated by a long dash.

3.5.12.3.1.1 Sequence. Sequence of phases and actions shall be arranged chronologically.

3.5.12.3.1.2 Checks. All checks shall be made from left to right or top to bottom except where chronology must take precedence.

3.5.12.3.2 Symbols definition. The following symbols shall be used in the checklist on every step applicable to identify certain conditions or duties:

- a. The symbol "O", which shall precede the step, shall be used to indicate if equipment is installed or available.
- b. Those duties that are the responsibility of the pilot/individual (not on the controls) shall be indicated by a circle around the step number or letter "4".
- c. A star symbol "★", which shall precede a step shall indicate that a detailed procedure for the step is located in the performance section of the condensed checklist.
- d. The asterisk symbol "\*", which shall precede the step, shall indicate that performance of the step is mandatory for all through-flights. The asterisked steps in this checklist shall be used for combat/tactical operations when authorized by the commander. The asterisk shall apply only to checks performed prior to takeoff.
- e. The letter "N", which shall precede the step, shall indicate the performance of a step that is mandatory for night flights.
- f. The letter "G", which shall precede the step, shall apply only to a task or step if the GPS is installed.
- g. The letter "F", which shall precede the step, shall indicate a task or step that requires a flight engineer, external operator, payload operator, or ground crew personnel function or response.
- h. The letter "E", which shall precede the step, shall indicate a task or step required for engine starts only for the purpose of engine performance runs up to, and including, TAXIING when there is NO INTENT TO FLY.

## MIL-PRF-63029J

3.5.12.3.3 Amplified checklist. The amplified checklist (Figure 49) shall consist of numbered items supplemented where necessary by explanatory material. Where required for emphasis, a brief explanation shall be provided as to why it is required. These checklists shall be provided in the operator's manual for each aircraft, and they shall be the basis of all operators' checklists. An amplified normal checklist shall be included for the pilot, pilot (not on the controls), and flight engineers, as applicable. A statement similar to the following shall be included only in the amplified checklist:

“Normal procedures are given primarily in checklist form and amplified as necessary in accompanying paragraph form when a detailed description of a procedure or maneuver is required. A condensed version of the amplified checklist, omitting all explanatory text including warnings, cautions, and notes, is contained in the Operator's Checklist, TM 1-XXXX-XXX-CL. The procedural steps are numbered to coincide with the corresponding numbered steps in this manual.”

3.5.12.3.4 Preflight check. The amplified preflight check shall include a before exterior check, if required, and the exterior and interior checks. The amplified checklist shall emphasize that the preflight is not intended to be a detailed mechanical inspection and that the order is a recommended sequence only. In addition the expanded sub-steps shall not need to be memorized or accomplished in a certain order. The preflight may be made as comprehensive as conditions warrant at the discretion of the pilot/UAS Mission Commander. UAS manuals shall include a thorough preflight of the ground control station and supporting equipment.

3.5.12.3.5 Before exterior check. When required by the aircraft configuration, all necessary actions that must be performed prior to starting the exterior check shall be included. Emphasis shall be placed on items that affect safety during the inspections to follow.

3.5.12.3.6 Exterior check. Only those exterior points that significantly affect the flight shall be included avoiding needless repetition of items which are the normal responsibility of the maintenance crew. The criteria on which these checks shall be based are safety of flight, items that have previously been a problem or that are anticipated to be a problem, and ease of accomplishing the check. Inspections usually should proceed counter-clockwise (as viewed from the top) around the aircraft.

3.5.12.3.7 Interior check. The complete interior check shall be described, including all necessary check items up to the point where the pilot is strapped/operator is in the seat. All necessary equipment including, but not limited to, a first aid kit, fire axes, pyrotechnic equipment, aircraft covers, tie downs, and control locks shall be stowed. A check of the headrest area of the ejection seat shall be included to determine that the face curtain handles are properly stowed, that the catapult pin is installed and connected to the removal mechanism, and that the catapult firing yoke is properly positioned and connected. Instructions shall be included to ensure that controls are positioned as necessary to facilitate the exterior check (only for those aircraft where the interior check is performed before the exterior check). On large aircraft, it may be necessary to include an interior check diagram.



## MIL-PRF-63029J

3.5.12.3.8 Crew/passenger briefing check. Instructions shall be provided to ensure that crew and passenger briefings have been completed prior to starting engines.

3.5.12.3.9 Before starting engine(s). Precautions to be observed and checks to be accomplished before starting engine(s) shall be included. Such checks as should be accomplished before starting engine(s), but which could not be properly accomplished during the interior check shall be included. Instructions for positioning important controls and checking important indicators shall be included. Insofar as is practicable, all controls shall be positioned as required for engine starting. Functional checks shall be included for those systems that can be checked before the engines are started. For those aircraft in which engine power is not necessary, flight controls shall be checked for free and correct movement. Instructions shall be provided on the use of external power or auxiliary power units and any necessary switching involved in its use.

3.5.12.3.10 Starting engine(s). The complete procedure for starting the engine(s) shall be provided, including the order of starting for multi-engine aircraft. Except when significant differences in procedures are required for multi-engine aircraft, engine start procedures shall not be repeated. For jet and turbine powered aircraft, the means to avoid hot starts and procedures to follow when a hot start is experienced shall be included. Procedures for engaging rotors for rotary wing aircraft shall be given.

3.5.12.3.11 Engine ground operations. When required, warm-up and ground operation power setting shall be specified. Any special precaution or limitation shall be stated. For rotary wing aircraft a requirement for flight control checks before the rotor is engaged shall be included, if applicable.

3.5.12.3.12 Before taxiing. All checks to be accomplished before taxiing, such as check flight controls for free and correct movement (for those aircraft which require engine power to perform this check), windows and doors, control locks, and hydraulic pressure checks shall be included.

3.5.12.3.13 Taxiing. Any unusual taxiing characteristics or techniques shall be described, including special instructions for engine cooling, reverse pitch, and use of brakes. A requirement that flight instruments be checked during taxiing shall be included.

3.5.12.3.14 Engine runup. Instructions shall include, but shall not be limited to, checking engine propeller/rotor operation, including power, ignition, and use of brakes.

3.5.12.3.15 Before takeoff. All checks, which must be accomplished immediately prior to takeoff/departure, shall be listed.

3.5.12.3.16 Lineup check. When aircraft configuration or mission requirements preclude performance of some of the takeoff checks before taxiing onto the active runway, a lineup check shall be provided. This may include activation of anti-icing/deicing system switches, transponder switches, setting or aligning gyros, and stabilizing power prior to starting takeoff.

## MIL-PRF-63029J

3.5.12.3.17 Takeoff. Takeoff techniques required to produce the results shown on the takeoff charts in Chapter 7 shall be covered in detail. When appropriate, manipulation of brakes and throttles/power levers, etc., shall be described. Detailed information shall be given regarding unique reactions of the aircraft during takeoff. Criteria for continuing a takeoff or aborting under various circumstances shall be included. Operational consideration and general rules contributing to hovering capability and power availability shall be stated. Unique hover/taxi, sideward and rearward flight techniques and power check shall be included. The necessity for a prepared runway shall be discussed for various conditions of altitude and weight of aircraft that may be required to operate from temporary or unfinished runways.

3.5.12.3.18 After takeoff. All actions and techniques to be accomplished immediately after takeoff shall be listed. If flap retraction procedures differ under various conditions including, but not limited to, heavy weight and weather, it shall be so stated. When applicable, minimum airspeed and altitude for retracting flaps shall be covered. A minimum flap retraction airspeed chart shall be included for aircraft of highly variable gross weight. All actions needed to establish the required climb shall be covered, including the airspeed at which the climb should be started.

3.5.12.3.19 Climb. A description of unique climb techniques required to produce the results stated in the climb charts in Chapter 7 shall be included. Unusual characteristics of the aircraft in climb shall be described. Since the preceding paragraph includes the climb checklist, this paragraph shall contain discussion only.

3.5.12.3.20 Cruise. An explanation shall be provided for all actions that must be performed when the transition from climb to cruise is made. Any particular matters that must be considered during cruise flight shall be described. Reference shall be made to Chapters 2 and 7 concerning fuel system management and other actions that should be considered during flight. Actual procedures shall not be covered here.

3.5.12.3.21 Descent-arrival. A checklist and discussion of this phase of operation shall be included as appropriate. The checklist shall include all checks that must be made immediately before and during a descent preparatory to landing. Special instructions regarding various types of descent shall be included as applicable, including any special devices that may be provided to facilitate descent.

3.5.12.3.22 Before landing. All checks that must be made immediately before entering the traffic pattern until the aircraft is committed to landing shall be covered.

3.5.12.3.23 Landing. A landing checklist and a narrative discussion of the landing problems and techniques shall be provided. The landing checklist shall include all actions to be performed from the time the landing is committed until it is affected. Landing techniques required to produce the results stated in the landing charts in Chapter 7 shall be included. Braking techniques and devices used during the landing and after-landing roll shall be described. Approach and landing airspeed corrections required to compensate for gusts shall

## MIL-PRF-63029J

be covered. In addition, landing techniques from the viewpoint of recommended maximum and minimum approach and landing airspeeds as related to aircraft flight classification, aircraft strength, aircraft touchdown bounce characteristics, and other aircraft characteristics shall be included. Reference shall be made to Chapter 7 for supplemental information provided by landing and approach speed charts. Coverage of approach and landing shall include cautions, when applicable, in the use of the engine during approach, performing a go-around, for the use of the angle-of-attack indicator in making an approach, etc. Shipboard landing techniques, when applicable, shall be included for rotary wing aircraft when unusual characteristics dictate.

3.5.12.3.24 Touch and go landings/go-around. All instructions including, but not limited to, trim changes and flap settings for executing these procedures shall be included. Proper throttle/power lever technique shall be emphasized, when applicable.

3.5.12.3.25 After landing. All checks and operations to be performed from immediately after landing until the parking area is reached shall be included.

3.5.12.3.26 Engine shutdown. A checklist shall be provided covering proper procedures and precautions for stopping engines.

3.5.12.3.27 Before leaving the aircraft. A checklist of settings of all controls, control locks, and safety devices for securing the aircraft shall be provided for pilots and crew, air vehicle operator, payload operator, external operator, and ground-crew personnel. A statement similar to the following shall be included:

“In addition to established requirements for reporting any system defects or unusual and excessive operations such as hard landings, the flight crew shall also make entries on DA Form 2408-13-1 to indicate when any limits of the operator’s manual have been exceeded.”

3.5.12.3.28 Checklist changes. The specific checks described above may be deleted or new checks added when approved by the acquiring activity (6.2).

3.5.12.4 Section III – Instrument flight <ch8sect3>. Unique qualities and capabilities of the aircraft under instrument flight conditions shall be briefly described. Only those procedures and techniques that are used for instrument flight that are different from normal procedures in FM 3-04.240 shall be discussed. Instrument flight conditions to be considered shall include instrument takeoff, climb, cruise, descent, and approaches; holding; and automatic approaches.

3.5.12.5 Section IV – Flight characteristics <ch8sect4>. Detailed unique flight characteristics of the particular aircraft that may be different from FM 3-04.203 shall be provided. Emphasis shall be placed on advantageous flight characteristics as well as on any dangerous tendencies. The extent of coverage shall depend principally on the type of aircraft being discussed.

## MIL-PRF-63029J

3.5.12.5.1 Stalls. The power-off and power-on stalling characteristics of the airplane in the takeoff, landing, and cruise configurations shall be described. Stalling characteristics shall also be included for the approach configuration if sufficiently different from landing. A definition of power-off and power-on as used in the discussion shall be included. Information about the stall warning shall also be included. Normal and accelerated stalls shall be covered, and recommended procedures for initiating stalls shall be included. Stall recovery technique shall be emphasized. For helicopters, appropriate information shall be included on blade stalls.

3.5.12.5.2 Stall chart (fixed wing only). Stalling airspeeds (with power-on and power-off configurations) for takeoff, landing, and cruise shall be presented showing the variations of bank angle and gross weight.

3.5.12.5.3 Spins (fixed wing only). Spin characteristics and limitations shall be given, including details of any special techniques recommended for recovery. Recovery techniques shall be given whether or not spins are permitted. Altitude lost in effecting a recovery and minimum altitude at which bailout must be effected if aircraft has not been brought under control shall be stated.

3.5.12.5.4 Diving. The diving characteristics of the aircraft shall be described with particular emphasis on high speed diving and compressibility effects. Dive recovery techniques and precautions shall be given, including any special information regarding power plant operation and trim changes. For highly maneuverable aircraft, dive recovery charts shall be included for various G pullouts given varying parameters of altitude, airspeed, and dive angle.

3.5.12.5.5 Maneuvering flight. Maneuvering flight shall be described, including characteristics under accelerated flight conditions. Stick forces shall be included, emphasizing conditions that may result in stick reversal.

3.5.12.5.6 Flight controls. Detailed coverage of the effectiveness and unusual reactions that may be encountered in the operation and use of the flight controls shall be included. All the various types of flight controls, such as ailerons, elevators, rudders, stipulators, trim tabs, speed brakes, slats, cyclic stick, and collective pitch shall be described. The text shall state when and how the various controls are used to achieve maximum benefits and what precautions must be observed. The capabilities and limitations of power-boosted systems when power boost is inoperative shall be covered.

3.5.12.5.7 Level flight. Characteristics of level flight under slow, cruising, and high speed conditions shall be described.

3.5.12.5.8 External loads. Changes in flight characteristics due to external loads shall be described.

3.5.12.5.9 Asymmetrical loads. Coverage of characteristics and techniques to be employed when operating with asymmetrical loads or configurations shall be presented.

## MIL-PRF-63029J

3.5.12.6 Section V – Adverse environmental conditions <ch8sect5>. Information relative to operations that are unique to the specific aircraft under adverse environmental conditions (snow, ice, rain, turbulent air flight, extreme cold and hot weather, desert operations, and high altitude operations) for parameters including, but not limited to, gross weight and aircraft configuration shall be provided. The information presented shall be primarily narrative in nature. Checklists shall be avoided; they shall be used only to cover specific procedures that are characteristic of all weather operations. A description of equipment shall not be included. An introductory paragraph shall be included explaining the function of this section. In addition coverage of duties to be accomplished before leaving the aircraft, including, but not limited to, leaving the canopy slightly open, positioning of doors, battery care, and installing covers shall be included for applicable environmental conditions.

3.5.12.6.1 Cold weather operations. A brief discussion of the general problems involved in maintaining satisfactory operations in extreme cold shall be included. The relationship of proper engine shutdown to subsequent engine starting shall be emphasized, and operations under icing conditions shall be covered. Any special problems resulting from operations when snow is present shall be included.

3.5.12.6.2 Preparation for flight. Special problems including, but not limited to, application of heat, removal of ice and snow from the aircraft surfaces, fuel and oil tank vents, pitot tubes, props, and supplying external power shall be addressed.

3.5.12.6.3 Engine starting. Any special precautions that must be observed before starting the engines shall be included. Cold weather starting techniques shall be explained including the use of special fuels and carburetor heat.

3.5.12.6.4 Warm-up and ground testing. This shall include, but shall not be limited to, coverage of carburetor heat, cowl flap position, and technique of switching from a special starting fuel. If oil dilution is available, the fuel boil-off procedure shall be covered, including a reference to the oil dilution table. The importance of ground testing of systems that may be adversely affected by cold weather shall be included.

3.5.12.6.5 Taxiing and hovering instructions. The unique techniques and precautions to be observed when taxiing on snow, ice, or slush covered water shall be explained, as well as, instructions for operator/ground crew to visually check wheels to ensure they are turning.

3.5.12.6.6 Before takeoff. Checks for ice and snow buildup on the aircraft shall be included.

3.5.12.6.7 Takeoff. Unique techniques and precautions to be observed when taking off under cold weather conditions shall be included. The effect of snow or ice covered runways on takeoff, of extremely cold weather on engine and aircraft performance, etc. shall be covered.

## MIL-PRF-63029J

3.5.12.6.8 During flight. Any special precautions that must be observed during flight in extreme cold, such as cycling propeller governing systems, shall be described; procedures for dealing with in-flight icing shall be described.

3.5.12.6.9 Descent. Any special instructions regarding descent as may be applicable to cold weather operation shall be included, such as switching on the auxiliary power unit early to ensure that it is sufficiently warmed up prior to landing.

3.5.12.6.10 Landing. Unique techniques and precautions to be observed during landing in cold weather shall be included. The use of brakes and reverse pitch propellers when landing on snow or ice covered runways shall be covered. Any restrictions regarding the use of landing or dive flaps when landing on snow or slush covered runways or slush covered water where ice is suspected shall be included.

3.5.12.6.11 Engine shutdown. The proper method of shutting down the engine shall be given, including a table showing the required oil dilution time for various temperatures, and the techniques and precautions to be observed in using oil dilution shall be covered. Operation of systems depending on engine oil (including, but not limited to, supercharger clutch and propeller governor), to ensure that these systems are supplied with diluted oil, shall be included. Complete instructions for purging normal fuel from the system and replacing with special fuel shall be included. Time, speed or other requirements for turbine temperature stabilization prior to shutdown shall be stated.

3.5.12.6.12 Desert and hot weather operations. The same requirements and procedures outlined in cold weather operations (3.5.12.6.1) shall apply to desert and hot weather operation.

3.5.12.6.13 Turbulence and thunderstorm operations. A discussion on the general qualities of the aircraft in turbulence and thunderstorms shall be included. A description of the techniques to be used shall be given and all preparations to be made before entering turbulence or thunderstorms shall be included.

3.5.12.6.14 Rain. General coverage of the problem of rain during each phase of flight, including before takeoff, takeoff, climb, and cruise, shall be included. Performance of the rain removal system shall be described.

3.5.12.6.15 Additional sections <ch8sect additional>. When specified by the acquiring activity (6.2), additional sections may be used.

3.5.13 Chapter 9 – Emergency Procedures <chapter9>.

3.5.13.1 General. Procedures to be followed in dealing with emergencies that could reasonably be encountered shall be provided. Minor malfunctions that do not adversely affect the continued safe operation of the aircraft and compound or multiple failure emergency procedures shall not be included. Emergency procedure titles shall be based on how the pilot

## MIL-PRF-63029J

recognizes the emergency rather than what caused the emergency (for example, “Low RPM” not “Governor Control failure”). Complete coverage shall be required regarding the recognition, feel, characteristics, and reaction of the aircraft during various emergencies affecting flight. All precautions to be observed in coping with an emergency shall be included. An emergency amplified checklist shall be included. Emergency procedures in connection with the utility systems shall be described in Chapter 2, Section IX. Emergency operation of utility systems shall be included only insofar as it may affect safety of flight. Emergencies shall be divided into the following categories as applicable:

- a. Engine
- b. Propeller/rotor
- c. Fire
- d. Fuel
- e. Electrical
- f. Hydraulic
- g. Landing and ditching (or for UAS: Takeoff, Landing and Ditching)
- h. Flight controls
- i. Bailout/ejection
- j. Mission equipment (when applicable)
- k. Shelter Malfunctions
- l. Other UAS Components

Within an emergency classification, emergencies that have identical corrective actions may be combined under one paragraph heading. Those checks that must be performed immediately in an emergency procedure shall be underlined, and a statement that such underlined steps must be performed immediately without reference to the checklist shall be included.

3.5.13.2 Section I – Aircraft systems <ch9sect1>. Emergency procedures to be performed in the event of an aircraft system malfunction under various conditions shall be provided.

- a. A statement similar to the one provided below shall be included:

“Emergency operation of mission equipment is provided insofar as its use affects safety of flight. Emergency procedures are presented in checklist form when applicable. A

## MIL-PRF-63029J

condensed version of these procedures is contained in the condensed checklist TM 1-XXXX-XXX-CL.”

b. A note similar to the one provided below shall be included:

**“NOTE**

The urgency of certain emergencies requires immediate and instinctive action by the pilot. The most important single consideration is aircraft control. All procedures are subordinate to this requirement.”

c. A statement similar to the one provided shall also be included:

“Terms may be defined as necessary to simplify the procedural memory steps within the existing emergency procedures. Each term shall be used as an emergency procedure step instead of listing the individual steps used to define the term. For example, the term “EMER ENG SHUTDOWN” is defined as engine stoppage without delay and is accomplished as follows:

1. Throttle – off.
2. **FUEL switches – OFF.**
3. **BAT switch – OFF.**”

For rotary wing aircraft, the definitions of emergency terms shall be included near the beginning of Chapter 9.

d. The following definitions shall be included as applicable:

“(1) LAND AS SOON AS POSSIBLE (always underlined) is defined as landing at the nearest suitable landing area (e.g., open field) without delay. The primary consideration is to ensure the survival of occupants.

(2) LAND AS SOON AS PRACTICABLE is defined as landing at a suitable landing area. The primary consideration is the urgency of the emergency.

(3) AUTOROTATE (always underlined) is defined as adjusting the flight controls as necessary to establish an autorotational descent and landing.”

3.5.13.2.1 Emergency equipment and exits. The following emergency equipment and exits shall be illustrated.



## MIL-PRF-63029J

a. The aircraft interior shall be illustrated showing Aviation Life Support Equipment (ALSE) permanently installed in the aircraft including, but not limited to, fire axes, flares, pyrotechnic pistols, and hand fire extinguishers (Figure 50).

b. If the aircraft is large enough to permit movement of personnel, emergency stations and routes of egress to be followed in flight and after crash landing on land or water shall be indicated for all personnel. Coding shall be used to differentiate between routes and exits to be used in flight and those to be used after a crash landing (Figure 50). This illustration shall be an interior view or as viewed by the occupants of the aircraft. It may be combined with the emergency equipment diagram and the emergency entrance diagram, unless the resulting illustration would be confusing.

c. A diagram shall be included to show points at which emergency personnel can enter into the aircraft after it has crash landed. This illustration may be combined with the routes of escape and exits diagram, unless the resulting illustration would be confusing.

3.5.13.2.2 Engine. Emergency procedures shall be described in the event of an engine malfunction under a variety of conditions.

3.5.13.2.2.1 Flight characteristics under partial power conditions. A description of the characteristics and reactions of the aircraft when flying with one or more inoperative engines or with an engine having only partial power capability shall be included. Emphasis shall be given to any special precautions that must be observed and any dangerous tendencies of the aircraft. Information shall be included on how to determine which engine is inoperative. The problems of maintaining altitude, directional control, and any other special considerations shall be discussed.

3.5.13.2.2.2 Engine malfunction under specific conditions. Additional paragraphs shall be included as necessary to indicate action to be taken in the event of engine malfunction under various conditions. Partial engine malfunctions as well as complete engine failure shall be described. A complete checklist procedure to be followed in shutting down the malfunctioning engine and establishing continued flight shall be included. Insofar as possible, shutdown procedure shall be identical to that required in the event of engine fire. Recommended best techniques and procedures for crash landing while operating within avoidance areas shall be discussed.

3.5.13.2.2.3 Engine malfunction during takeoff and low altitude/low airspeed flight. This shall include an abort during the takeoff run, immediately after liftoff and continued flight. Coverage shall be included for both complete engine failure and partial loss of power. For rotary wing aircraft, differentiation between engine malfunction while at a hover and engine malfunction after takeoff (in translational lift) shall be included. Information shall be included, but not limited to, jettisoning external stores, landing gear retraction, pilot techniques, and best airspeed for minimum power required (partial loss of power).

## MIL-PRF-63029J

3.5.13.2.2.4 Engine malfunction during cruise. Reference shall be made to the performance chart data in Chapter 7 covering cruise control with one or more engines inoperative. The effect of loss of each engine on the various aircraft systems and equipment shall be included. Procedures to be followed in the event of partial power loss as well as for the complete engine failure shall be included.

3.5.13.2.2.5 Engine malfunction during final approach. For multi-engine aircraft, procedures shall be provided for loss of one engine while on final approach in the landing configuration. Information shall be included concerning application of maximum controllable power, jettisoning external stores if applicable, landing gear position, use of flaps, pilot techniques, and airspeed requirements.

3.5.13.2.2.6 Engine restart during flight. Instructions for proper means for restarting an engine in flight and resuming normal flight shall be presented. Special emphasis shall be placed on parameters such as altitude, airspeed, and rpm. If considered advantageous, they may be presented in chart form. A warning shall be included that the engine should not be restarted unless it can be determined that it would be reasonably safe to do so.

3.5.13.2.2.7 Maximum glide. Glide requirements that shall result in maximum range with no power available shall be provided. This information is required for all single-engine and twin-engine aircraft. A graph showing glide distance attainable from the service ceiling to sea level shall be included (Figure 51).

3.5.13.2.2.8 Autorotational descent (rotary wing). A chart that presents autorotational rate of descent versus indicated airspeed at normal rotor speed shall be provided (Figure 52). The indicated airspeeds for minimum rate of descent and maximum glide distance shall be shown on the chart. Data and/or instructions for determining autorotational descent information for variations in aircraft configurations shall also be provided.

3.5.13.2.2.9 Landing with one or more engines inoperative. The recommended procedure shall be described, including important precautions. A brief discussion of any changes that include, but are not limited to, the use of landing gear, wing flaps, and slats during such landing shall be included. For single-engine and twin-engine aircraft, proper landing procedures with no power shall be emphasized. For rotary wing aircraft, reference shall be made to the height velocity diagram.

3.5.13.2.2.10 Go-around with one or more engines inoperative (fixed wing). Recommended procedures shall be described, including important precautions.

3.5.13.2.2.11 Height velocity. The minimum height for safe landing following loss of power for both single and multi-engine helicopters shall be provided. Plots of height required for safe auto-rotational landing after loss of power and initial engine failure shall be included as applicable. For a multi-engine helicopter a recommended approach corridor with the critical engines inoperative shall be shown on the plot. Regions of caution, avoidance, and safe operation shall be shown (Figure 53). The plots shall be based on initiation of the necessary

## MIL-PRF-63029J

manual collective pitch control motion after at least a two-second delay following loss of power, or as approved by the acquiring activity (6.2).

3.5.13.2.3 Propeller/rotor, transmissions, and drive systems. Emergency procedures shall be described in the event of propeller/rotor, transmission, or drive system failure.

3.5.13.2.3.1 Propeller failure (fixed wing). Instructions shall be given regarding recommended procedures in the event of a runaway propeller and other types of propeller failure. Instructions shall be included regarding action to be taken if propeller does not feather properly.

3.5.13.2.3.2 Tail rotor failure and directional control malfunctions. Instructions shall be given regarding all modes of directional control malfunctions and tail rotor failures. Coverage shall include emergency procedures to be used in the event of failures during takeoff, hovering, in flight, and while landing. Instructions for maintaining powered flight as opposed to autorotation shall be included.

3.5.13.2.3.3 Malfunctions of main rotor transmission and drive systems. Differentiation between malfunctions with the drive system between the engine and transmission, and malfunctions of the drive system between the transmission and main rotor shall be included. Actual and erroneous instrument/warning light indications shall be discussed, including procedures for specific malfunctions.

3.5.13.2.3.4 Other emergencies. Other emergencies such as ground resonance and mast bumping shall be described. Restrictions and preventive actions shall be described.

3.5.13.2.4 Fire. Emergency procedures shall be included for fires as directed in the following paragraphs.

3.5.13.2.4.1 Engine fire. Instructions shall be included regarding the recommended method of dealing with engine fires on the ground and during flight. Insofar as possible, engine shutdown procedures shall be identical to those used during engine failure.

3.5.13.2.4.2 Fuselage fire. Instructions shall be included regarding procedures to be followed when a fuselage fire breaks out. Warnings regarding dangers involved in using fire extinguishing agents shall be included.

3.5.13.2.4.3 Wing fire. Instructions shall be included on means of dealing with wing fires, including shutting down systems which may be feeding the fire.

3.5.13.2.4.4 Electrical fire. Instructions for dealing with an electrical fire shall be included. If certain aircraft fire extinguishers are not to be used for electrical fires, that information shall be included.

## MIL-PRF-63029J

3.5.13.2.4.5 Smoke and fume elimination. Instructions shall be given for most rapid means of dissipating smoke and toxic fumes.

3.5.13.2.5 Fuel system. Procedures shall be given for dealing with fuel system failures and shall include a description of metering system failures, fuel pump failures, and control linkage failures (loss of fuel control with fuel input in a fixed position). Emergency procedures shall be included for each condition.

3.5.13.2.6 Electrical system. Instructions shall be given for methods of dealing with electrical system failures. Procedures shall be expressed as actions to be taken involving circuit breakers. For push-pull types, procedures shall indicate in or out. Where the circuit breakers are a switch type, procedures shall indicate off or on.

3.5.13.2.7 Hydraulic system. Instructions shall be given for dealing with hydraulic system component failures.

3.5.13.2.8 Landing and ditching. Instructions shall be given regarding landing and ditching emergency procedures as described in the following paragraphs.

3.5.13.2.8.1 Emergency descent. The means of accomplishing an emergency descent shall be provided. Emergency descent is a maximum effort in which damage to the aircraft or power plant is considered secondary to getting the aircraft on the ground.

3.5.13.2.8.2 Landing emergencies. Preparation, warning signals to crew, approach, crew/passenger positions, harness locks, landing technique, routes, and methods of crew exits shall be included for both hard and soft ground. Landings with one or more landing gears retracted, flat tires, no wing flaps, and landing on unprepared runways shall also be covered. Information regarding pilot techniques for forced landings in trees or wooded areas shall also be included.

3.5.13.2.8.3 Body positions. The body positions to be used by passengers and crew in emergency landings shall be illustrated.

3.5.13.2.8.4 Ditching. Instructions shall be included for ditching the aircraft. The ditching capabilities of the aircraft and the advantages of ditching versus bailout shall be included. The following shall be described: preparation; warning signals to crew; approach; crew/passenger positions; ditching equipment, such as ditching belts and bulkheads; landing techniques; duties of each crewmember immediately after ditching; and methods of crew exits. As applicable, an illustration shall be included showing the position of each crewmember during ditching and crash landing.

3.5.13.2.9 Flight controls. Procedures to be employed in event of flight control failure shall be provided.

## MIL-PRF-63029J

3.5.13.2.10 Bailout/eject. For all aircraft with established crew bailout or ejection procedures, the techniques, precautions, and warning signals for leaving the aircraft in flight shall be described, including instructions for separation from the seat. Bailout procedures to be used when seat ejection fails shall be included. The proper method of preparing the aircraft for bailout and method of jettisoning pilot's compartment enclosures and doors shall be described. A pictorial sequence of operations for ejection shall be provided, including alternate methods of removing safety pins where applicable.

3.5.13.3 Section II – Mission equipment <ch9sect2>. Emergency procedures shall be outlined for malfunctioning mission equipment that constitutes a safety hazard.

3.5.13.3.1 Emergency jettisoning. All means of accomplishing emergency jettisoning of fuel, cargo, and equipment shall be covered. Appropriate cautions relative to possible damage that may result, sudden shifting of CG, etc. shall be included.

3.5.13.3.2 Ground Control Malfunctions. Emergency procedures shall be outlined for malfunctioning UAS Ground Control equipment that constitutes a safety hazard as described in the following paragraphs.

3.5.13.3.2.1 Ground Control Station Malfunctions. Procedures to be employed in event of ground control equipment failure shall be provided.

3.5.13.3.2.2 Data Link Malfunctions. Procedures to be employed in event of primary or secondary data link failure shall be provided.

3.5.13.3.3 Ground Control Support Equipment Malfunctions. Procedures to be employed in event of UAS system support equipment failure that constitutes a safety hazard during flight/system operation shall be provided (Launcher/RATO/Arresting gear failure, automated landing systems failure, etc.).

3.5.14 References <references>. A listing of official publications cited within the manual applicable to flight crews shall be provided. The listing shall contain only those publications referenced in the manual, and shall not contain blank forms. The list references shall be provided as Appendix A.

3.5.15 Abbreviations and terms <abbreviations>. Definitions of all abbreviations and terms used throughout the manual shall be provided. The definition list shall be provided as Appendix B (B.3.10).

3.5.16 Appendices. Appendices shall immediately follow the abbreviations section of the manual. Appendices shall be included when specified by the acquiring activity (6.2).

3.5.17 Index <index>. If required by acquiring activity (6.2), the index shall list in alphabetical order, every titled paragraph, figure, and table contained in the TM (B.3.15).

## MIL-PRF-63029J

3.5.18 Authentication page <authent>. The authentication page (Figure 54), provided by the acquiring activity (6.2), shall be the last printed text page of the TM or if foldout pages are included, the authentication page shall be the last printed text page before the foldout pages. For changes, the authentication block shall be included on the change transmittal sheet(s). The authentication block shall be placed after all of the other information on the change transmittal sheet(s).

3.5.19 Foldouts <foldsect>. When foldouts are provided they shall be placed at the end of the Operator's Manual immediately following DA Form 2028. Refer to Appendix E for identification and numbering of foldout figures and foldout pages.

3.5.20 DA Form 2028 <da2028>. DA Form 2028 (Figure 56) shall be provided in the back of the manual immediately following the alphabetical index. Instructions for sending an electronic DA Form 2028 shall also be included (Figure 55).

3.5.21 Metric conversion chart <metrics>. A metric conversion chart similar to the chart shown in Figure 67 shall be placed at the end of the manual following the DA Form 2028.

### 3.6 Operator's checklist (-CL).

3.6.1 General. The operator's checklist (-CL) is a condensed version of Chapter 8 and 9 of the operator's manual which consist of a series of controls (or checks) and the required actions. The sequence of items (or checks) appearing in the operator's checklist shall be identical to those appearing in the amplified checklist of the operator's manual. In unusual circumstances, explanatory material shall be used in the -CL in the form of warnings, cautions, and notes, only if specified by the acquiring activity (6.2). The contents of the -CL shall be as described in the paragraphs below.

3.6.2 Standard operator's checklist <standardcl>. The standard operator's checklist shall comply with the following requirements, except those which are designated as applying specifically to alternate operator's checklists (3.6.3).

3.6.2.1 Detailed requirements for standard operator's checklists. Operator's standard checklists shall be prepared in accordance with the following outline indicated below:

- a. Cover
- b. Change transmittal page
- c. General information and scope
- d. Normal procedures
- e. Emergency procedures

## MIL-PRF-63029J

- f. Performance data
- g. Foldouts
- h. Authentication Page
- i. Metrics conversion chart

3.6.2.2 Cover <cover>. Covers shall be prepared in accordance with Figure 57. Following the TM title, the following notices shall be provided in the order listed below, as applicable. Refer to 3.5.4.1.2 through 3.5.4.1.6 for explanations of these items.

- a. Export control notice <export> (as applicable)
- b. Distribution statement <dist>
- c. Destruction notice. <destr> (as applicable)
- d. Disclosure notice. <discl> (as applicable)
- e. Supersedure notice. <super> (as applicable)

3.6.2.3 Change transmittal page <chginsht>. A change transmittal page (Figure 58) shall be prepared for each change and shall be included in the change package. The change transmittal page shall not be numbered. The change transmittal page shall contain the change number, authority notice address, change date, print title information, and distribution statement/block. The list of pages for removal and insertion shall be provided.

3.6.2.4 General information and scope <geninfo>. The general information and scope shall indicate the purpose of the checklist, how and when it is to be used, and scope, including an explanation of the content of the normal and emergency procedures that appear in the checklist. An applicable reporting errors and recommending improvements statement shall be included. The reporting errors and recommending improvements statement shall be provided by the acquiring activity since this statement is subject to change either due to an address change or statement tailoring (6.2). DA Form 2028s shall not be included. An explanation of the symbols (3.5.12.3.2) used throughout the procedures shall also be provided. When applicable, information that a review for hazardous materials and ozone depleting chemicals has been done and non-hazardous materials and chemicals have been substituted when possible shall also be included.

3.6.2.5 Normal procedures <normal>. A condensed version of the normal procedures or crew duties portion of the applicable operator's manual (-10) (3.5.12) shall be developed (Figure 59). When required by the acquiring activity (6.2), a list of crewmembers' duties shall be prepared.

## MIL-PRF-63029J

3.6.2.6 Through-flight checklist <thruflight>. If a through-flight checklist is required, it shall be included in normal procedures (3.6.2.5) following the abbreviated checklist. It shall consist of all through-flight checks marked by an asterisk from the normal procedures section of the applicable operator's manual. The checks shall be numbered sequentially. In addition to through-flight, this checklist shall be used for combat/tactical operations when authorized by the commander. Procedures shall be highly abbreviated and shall use abbreviations that are defined in the operator's TM.

3.6.2.7 Emergency procedures <emergency>. A condensed version of the emergency procedures or crew duties portion of the applicable operator's manual (-10) shall be developed (Figure B-2). The emergency requirements shall be subdivided into 12 classifications as listed in 3.5.13.1, as applicable. The underlined items shall be the steps that must be performed immediately without reference to the checklist. Procedures shall be highly abbreviated and shall use abbreviations that are defined in the operator's (-10) TM. When required by the acquiring activity (6.2), a list of crewmembers' duties shall be prepared.

3.6.2.8 Performance data <perfdata>. Charts, tables, and checklists used during preflight, takeoff, cruise, landing, and shutdown shall be included.

3.6.2.8.1 Performance data charts <figure>. The acquiring activity shall specify the use of performance data charts in the checklist and the format these charts shall follow (6.2). The data to be included in the performance data charts shall be the same data as provided in the charts appearing in the performance data portion of the operator's manual.

3.6.2.8.2 Performance checks <check>. When applicable, detailed performance checks of selected procedures, as indicated by the acquiring activity (6.2), shall precede the performance data charts. Performance checks provided in Chapter 8 of the Operator's manual that have the star symbol (★) preceding those checks shall be included in the performance data section. When applicable, performance checks for mission equipment shall follow the detailed performance checks. The detailed performance checks shall appear in the same order/sequence as they appear in the Chapter 8 checklist.

3.6.2.9 Foldouts <foldsect>. When foldouts are provided they shall be placed at the end of the manual. Refer to Appendix E for identification and numbering of foldout figures and foldout pages.

3.6.2.10 Authentication page <authent>. An authentication page (Figure 54) shall be placed immediately preceding the back cover.

3.6.2.11 Metric conversion chart <metrics>. A metric conversion chart similar to the chart shown in Figure 67 shall be placed at the end of the manual.

3.6.3 Detailed requirements for alternate operator's checklist <alternatectl>. The acquiring activity (6.2) shall have the option to specify that a one or two page alternate operator's



## MIL-PRF-63029J

checklist (Figure 60) be prepared instead of the standard operator's checklist following the outline indicated below:

- a. Front Matter
- b. General information and scope
- c. Normal procedures
- d. Authentication Block
- e. Emergency procedures

3.6.3.1 Front Matter <alternatefront>. The alternate operator's checklist front matter shall contain the TM title and additional subtitles, to include nomenclature, model number, national stock number and/or part number, and end item code; notices; and the publication date. Following the TM title and additional required subtitles, the following notices shall be provided in the order listed below, as applicable. Refer to 3.5.4.1.2 through 3.5.4.1.6 for explanations of these items.

- a. Export control notice. <export> (as applicable)
- b. Distribution statement. <dist>
- c. Destruction notice. <destr> (as applicable)
- d. Disclosure notice. <discl> (as applicable)
- e. Supersedure notice. <super> (as applicable)

3.6.3.2 General information and scope<geninfo>. The general information shall contain a usage statement and any information aiding to the use of the TM to include symbols used within the TM.

3.6.3.3 Normal Procedures <normal>. A condensed version of the normal procedures or crew duties portion of the applicable operator's manual (-10) shall be developed according to 3.6.2.5.

3.6.3.4 Emergency Procedures <emergency>. A condensed version of the emergency procedures or crew duties portion of the applicable operator's manual (-10) shall be developed according to 3.6.2.7.

## MIL-PRF-63029J

3.7 Maintenance test flight manual (-MTF).

3.7.1 Detailed requirements for maintenance test flight manual. An MTF manual shall be prepared in accordance with the following outline indicated below (additional sections shall be added by the acquiring activity (6.2) when required):

- a. Front matter.
- b. Section 1. Introduction.
- c. Section 2. Maintenance test flight checklist.
- d. Section 3. Troubleshooting guides. (as applicable)
- e. Section 4. Special/detailed procedures.
- f. Section 5. Charts and forms.
- g. Foldouts
- h. Authentication Page
- i. Metric Conversion Chart

3.7.2 Front matter.

3.7.2.1 Cover <cover>. The cover shall conform to Figure 61. The title shall identify the type, model, series of subject aircraft, and EIC. Following the TM title, the following notices shall be provided in the order listed below, as applicable (refer to 3.5.4.1.2 through 3.5.4.1.6 for explanations of these statements and notices).

- a. Export control notice. <export> (as applicable)
- b. Distribution statement. <dist>
- c. Destruction notice. <destr> (as applicable)
- d. Disclosure notice. <discl> (as applicable)
- e. Supersedure notice. <super> (as applicable)

## MIL-PRF-63029J

3.7.2.2 Warning page <warnsum>. The warning page shall contain a warning statement similar to the following:

**WARNING**

A maintenance test flight is an exceptionally demanding operation and requires a thorough flight readiness inspection (pre-flight). The flight readiness inspection is prescribed in TM 1-XXXX-XXX-10 (operator's manual) and must be completed prior to each MTF. Emergency procedures are found in the applicable operator's manual (-10) and checklist (-CL) and are not duplicated in this publication. Prior to each maintenance test flight, the pilot shall contact maintenance/quality control personnel to determine the maintenance that has been performed. This manual should be used only by qualified maintenance test flight pilots as required by AR 95-1.

3.7.2.3 Change transmittal page <chginsst>. A change transmittal page shall be provided. The change transmittal page shall provide the information shown in Figure 62. In addition, when the MTF has been reviewed for the presence of environmental and hazardous material information, the ODC statement and hazardous materials statement provided on the abbreviated title page shall be repeated (3.5.4.5.1).

3.7.2.4 Abbreviated title page <titlepage>/table of contents <contents>. Information for reporting errors and making recommendations shall be placed at the beginning of the abbreviated title page/table of contents. When applicable, information that a review for hazardous materials and ozone depleting chemicals has been done and non-hazardous materials and chemicals have been substituted when possible shall also be included. The procedures in 3.5.4.5 shall be followed; however, referral to DA Form 2028's shall be directed to the Operator's Manual. The table of contents shall list the chapters and main paragraphs in the same order and with the exact titles used in the text. The only exception to this shall be the Introduction chapter where no main paragraphs are included. The Table of Contents shall be placed after the reporting of errors (Figure 63).

3.7.3 Section I – Introduction <mtf-intro>.

3.7.3.1 General. Information of a general nature including the definition of an MTF, the purpose, and instructions specific to the checklist shall be provided.

3.7.3.2 Purpose. The purpose of the MTF manual shall be to provide complete instructions for performing an MTF for a specific model, type, and series aircraft. For the specific criteria which require a general or limited MTF, reference shall be made to TM 1-1500-328-23 and the applicable aviation field and sustainment maintenance manuals.

3.7.3.3 Definitions. The following definitions shall be included:

a. Maintenance test flight. A flight for which the primary mission is to determine airworthiness, i.e., that the airframe, power plant accessories and items of equipment are

## MIL-PRF-63029J

functioning in accordance with predetermined requirements in the intended operational environment.

b. Warnings, cautions, and notes. Warnings, cautions, and notes are used to emphasize important and critical instructions and are used for the following conditions.

**WARNING**

Identifies and highlights an essential operating or maintenance procedure, practice, condition, statement, etc. which if not strictly observed, could result in injury to, or death of, personnel or long term health hazards to the person performing that procedure.

**CAUTION**

Identifies and highlights an essential operating or maintenance procedure, practice, condition, statement, etc. which, if not strictly observed, could result in damage to, or destruction of, equipment or loss of mission effectiveness.

**NOTE**

Identifies and highlights an essential operating or maintenance procedure, condition, or statement.

3.7.3.4 General Information. The following information shall be provided:

- a. This manual shall cover only MTFs of aircraft (insert type, model, and series) and in no way supersedes any information contained in TM 1-XXXX-XXX-10 or -CL, but is to be used in conjunction with the -10 or -CL. For the purpose of MTFs only, the MTF manual shall satisfy all of the requirements of the -CL from Interior Check through Engine Shutdown.
- b. Crew requirements shall be as specified in TM 1-1500-328-23 and TM 1-XXXX-XXX-10.
- c. The duration of a general or limited test flight shall be in accordance with the requirements of TM 1-1500-328-23.

3.7.3.5 Special instructions. The following special items of interest shall be included:

- a. Cargo and passengers shall be prohibited on MTFs.
- b. Forms and records shall be checked prior to the MTF to determine what maintenance has been performed and the type of MTF required (i.e., general or limited).

## MIL-PRF-63029J

- c. The configuration of the aircraft shall be established prior to each MTF in order to determine performance parameters.
- d. A thorough post test flight inspection shall be performed to the extent necessary to ensure that deficiencies that may have developed as a result of the MTF are detected.
- e. When an MTF is required to ensure proper operation of a specific system(s), references shall be made to the applicable maintenance manuals for the limits of that system.
- f. The symbols identified and described in 3.5.12.3.2 shall be used in the MTF checklist to identify certain conditions or duties. In addition, the following symbols may be identified and described for certain conditions or duties:
1. Two asterisk symbols “\*\*” (double-asterisk), which shall precede the step, shall indicate that the performance of the step is mandatory for all maintenance test flights.
  2. The letter “T”, (T-Operator Manual) which shall precede the step, shall indicate a task or step required by the operator’s manual.
- g. A check sheet (Figure 64) shall be developed for recording the results of test flights. When a test flight is performed to determine if specific equipment or systems are operating properly, completion of only that portion of the MTF check sheet applicable to the specific equipment or system being tested shall be required. Continuation sheets may be used when necessary. Items that prove to be unsatisfactory during the test flight and require corrective action shall be listed in the remarks block during flight and transferred to DA Form 2408-13-1 immediately after termination of the flight. The sheet shall be attached to the DA Form 2408-13-1 upon completion. After accumulation of two or more sheets, the data shall be reviewed to determine if trends are developing.

3.7.4 Section 2 – MTF checklist <checklist>. MTF requirements for specific Army aircraft shall be provided. This includes specific aircraft test weight and center of gravity limits required for completion of individual tests. Criteria for performing MTFs shall be in accordance with TM 1-1500-328-23. Requirements shall ensure a thorough inspection on the aircraft before flight during flight, and upon completion of the MTF. Unless otherwise specified by the acquiring activity (6.2), checklist items shall include those that are contained in the applicable aircraft operator’s checklist plus those MTF checks peculiar to the aircraft in question.

In addition to the draft TM, the acquiring activity may require submission of an aerodynamic report illustrating the derivation of the data entered on the charts included in the TM (6.2). The report should include an analysis leading to the establishment of lift and drag values used in the calculations, aircraft efficiency and compressibility correction factors, methods of computing power or thrust required and available, a discussion of duct loss and propeller efficiencies, and adequate references to appropriate wind tunnel or flight test data. Calculation methods need to be fully explained and a sample calculation given. The calculations should be

## MIL-PRF-63029J

presented in sufficient detail to permit ready review and check of conclusions and to enable additional calculations to be made.

3.7.5 Section 3 – Troubleshooting Guides <troubleshoot>. When troubleshooting guides are not provided, a statement that troubleshooting information can be found in the applicable maintenance manual should be provided. Refer to Appendix D for troubleshooting guide style and formatting.

3.7.6 Section 4 – Special/Detailed Procedures <specialprocs>. Those special/detailed procedures that are referenced in Section 2 shall be included. Complete instructions for each procedure shall be listed. Examples of special/detailed procedures shall include rotor smoothing techniques, speed trim checks, engine conditioning, engine starting, etc. (Figure 65). The special/detailed procedures shall be specified by the acquiring activity (6.2).

3.7.7 Section 5 – Charts and Forms <chartsforms>.

3.7.7.1 General. Forms and charts (Figure 66), shall be prepared, as necessary, to help perform and record MTFs. Charts shall be prepared that shall include, but not be limited to, bleed band opening envelope, turbine entire analysis check (TEC), and power adjusting. A list of required charts, including the contents, size, and format, shall be provided by the acquiring activity (6.2). The number of foldouts shall be kept to a minimum. Fold-up charts shall not be used. Placement and identification of foldouts are provided in Appendix E. The forms shall be used to record readings, pressures, rpm, etc. obtained during MTFs.

3.7.7.2 List of charts <ListOfCharts>. A complete list of charts shall be provided. The figure number, title, and page number shall be included. The charts shall be listed in order of their appearance.

3.7.7.3 Maintenance test flight check sheets. A check sheet, similar to the one in Figure 64, shall be provided for use by the person(s) conducting the checks.

3.7.8 Appendices <appendix>. Appendices shall immediately follow the last chapter of the manual. Appendixes shall be included when specified by the acquiring activity (6.2).

3.7.9 Authentication page <authent>. An authentication page (Figure 54) shall be placed immediately preceding the back cover.

3.7.10 Foldouts <foldsect>. When foldouts are provided they shall be placed at the end of the manual. Refer to Appendix D for identification and numbering of foldout figures and foldout pages.

3.7.11 Metric conversion chart <metric>. A chart, similar to the chart shown in Figure 67, shall be included at the back of the manual.

## MIL-PRF-63029J

#### 4. VERIFICATION.

4.1 Validation. Prior to verification the contractor must conduct a validation of the technical manual. DA Pam 25-40 and AMC Regulations 25-30 and 25-76 provide guidance and direction for verification and validation. The government has the right to observe the validation. Refer to AMC Pamphlet 25-31 for validation types, performance, conduct, criteria and other requirements.

4.2 Verification. Prior to Department of Army authentication, TMs must be verified. Verification must be performed with production configuration equipment.

4.2.1 Contractor-developed TMs. For contractor-developed TMs the acquiring activity defines the roles of the contractor and the Army in validation and verification requirements in the contract. The technical publication element of the acquiring activity (6.2) provides guidance to the contractor and for review, verification, and acceptance of deliverable products.

4.2.2 Verification Plan. The technical publications element of the acquiring activity (6.2) shall prepare and coordinate a verification plan with user representative to ensure that the equipment publication is tested and proved to be suitable for use by the target audience. Guidance is provided in AMC Pamphlet 25-31.

4.2.2.1 Verification Method. Verification plan will identify one or a combination of the following methods to be accomplished, as set forth in the verification plan agreed to in writing by TRADOC and Commander, USAMC Logistics Support Activity:

- a. Technical publications verification as a separate event.
- b. Verification combined with technical publications validation.
- c. Verification combined with Developmental Testing/Operational Testing.
- d. Verification of COTS manuals and supplements.
- e. Verification combined with Logistics Demonstration (LD) – Only if production configuration equipment is used for LD, Refer to AR 700-127 for verification in conjunction with LD.

4.2.3 TRADOC Involvement. If the project has a TRADOC Systems Manager (TSM), accomplish all coordination and invitation through the assigned TSM.

4.2.4 Usability and Accuracy. The acquiring activity will verify usability and technical accuracy of the technical manual. Usability will be considered equally as important as technical accuracy.

4.2.5 Procedural Verification. A 100 percent verification of all procedures shall be performed either hands on by target personnel expected to use and maintain the equipment when

## MIL-PRF-63029J

deployed (preferred) or desktop review. There is no assumption that simple tasks can be performed. Each task must be proven to be accurate and useable through the verification process; one successful iteration will be performed.

4.2.6 Monitoring. Performance of all tasks will be monitored by experienced government subject matter experts (SMEs).

4.2.7 Concurrence. A publication concurrence sheet is required for each publication at verification. It is available in AMC Pamphlet 25-31. The following agencies/agency representatives are required to sign the publication concurrence sheet to indicate verification is complete and satisfactory; however the technical publications representative is the final acceptance/rejection decision authority and can be overridden only by evident factors indicating safety violations:

- a. Publications manager/representative
- b. Equipment Specialist Representative
- c. Target Audience Representative
- d. TRADOC/depot Representative
- e. Contractor Representative (if present)
- f. Security Directorate Representative (if present)
- g. Safety Office Representative
- h. Product Assurance Directorate Representative (if present)
- i. Logistics Support Agency Representative (if present)
- j. Other Representatives (if present)

## 5. PACKAGING.

5.1 Packaging. For acquisition purposes, the packaging requirements shall be as specified in the contract or order (see 6.2). When packaging of materiel is to be performed by DoD or in-house contractor personnel, these personnel need to contact the responsible packaging activity to ascertain packaging requirements. Packaging requirements are maintained by the Inventory Control Point's packaging activities within the Military Service or Defense Agency, or within the military service's system commands. Packaging data retrieval is available from the managing Military Department's or Defense Agency's automated packaging files, CD-ROM products, or by contacting the responsible packaging activity.

## 6. NOTES.

This section contains information of a general or explanatory nature which may be helpful but is not mandatory.

6.1 Intended use. This specification is to be used for information and guidance in writing technical manuals for operator's manuals, checklists and MTF manuals for Army aircraft.



## MIL-PRF-63029J

6.2 Acquisition requirements. Acquisition documents should specify the following:

- a. Title, number, and date of the specification
- b. Distribution statement (see 3.5.4.1.3)
- c. Use of destruction notice (see 3.5.4.1.4)
- d. Use of disclosure notice (see 3.5.4.1.5)
- e. Reporting errors and recommending improvements statement (see 3.5.4.5.1)
- f. Location of emergency systems (see 3.5.6.1.1.2)
- g. Provide a list of primary, alternate, and emergency fuels (see 3.5.6.15.3)
- h. Add sections describing aircraft and systems to Chapter 2 (see 3.5.6.16)
- i. For systems with MFD, the Control/Indicator table omitted or altered (see 3.5.7.2.2.a)
- j. Provide standard operational avionics data, if existing (see 3.5.7.2.3)
- k. Add sections describing avionics equipment to Chapter 3 (see 3.5.7.6)
- l. Appendix for mission avionics equipment description (see 3.5.8.2.)
- m. Add sections describing mission equipment to Chapter 4 (see 3.5.8.6)
- n. Whether lateral CG limitations is described (see 3.5.9.5.1 and 3.5.10.7)
- o. Expression for airspeeds if other than as specified (see 3.5.9.6.1)
- p. Add sections to allow for added limits or restrictions for specific aircraft (see 3.5.9.9)
- q. Include a statement about usable oil capacity, equivalent in pounds, total moments and fuselage station number (see 3.5.10.3.2)
- r. Add sections describing weight/balance and loading to Chapter 6 (see 3.5.10.8)
- s. Submission of an aerodynamic report illustrating the derivation of the data entered on the charts (see 3.5.11.1)
- t. The basis for performance data charts if other than from flight test reports (see 3.5.11.1.1)
- u. A configuration that is other than as specified (see 3.5.11.1.4)
- v. Add data charts for alternate fuels (see 3.5.11.1.5)

## MIL-PRF-63029J

- w. Whether standard day, standard conditions, standard temperature, or density altitude should be mentioned (see 3.5.11.1.6)
- x. Create rotary wing performance data charts other than as specified (see 3.5.11.1.10)
- y. Additional charts peculiar to certain aircraft, such as multi-engine, to be included (see 3.5.11.1.10)
- z. Create fixed wing performance data charts other than as specified (see 3.5.11.1.11)
- aa. If additional use of performance data charts may be included (see 3.5.11.3b)
- ab. Add charts to supplement the takeoff chart (see 3.5.11.3.1.5)
- ac. Use of drag chart sub-graphs for alternate aircraft configurations for (see 3.5.11.3.1.6)
- ad. Provide particular altitudes and temperatures for cruise chart (see 3.5.11.3.1.7)
- ae. For airspeed calibration chart, calibration data for airspeed, altitude, and temperature may be omitted (see 3.5.11.3.1.9)
- af. If data are needed for an optimum cruise chart (see 3. 5.11.3.1.10)
- ag. Flap settings and other applicable information will be provided for the rotation/takeoff airspeed chart (see 3.5.11.3.2.5)
- ah. Provide particular altitudes, configuration, and temperatures for cruise chart (see 3.5.11.3.2.13)
- ai. Indicate if single engine data are to be placed on cruise charts for multi-engine aircraft (see 3.5.11.3.2.13)
- aj. Approach speed charts not valid for all configurations (see 3.5.11.3.2.15)
- ak. Indicate if the landing chart will be valid for stores configurations other than as specified (see 3.5.11.3.2.16)
- al. Indicate for airspeed calibration chart on aircraft whose air data system position errors are insignificant whether airspeed, altitude, and temperature calibration data is to be omitted (see 3.5.11.3.2.17)
- am. Indicate if data are needed for an optimum cruise chart (see 3.5.11.3.2.18)
- an. Indicate if headwind and tailwind impact on optimum cruise shall be provided (see 3.5.11.3.2.18)
- ao. Indicate if specific checks are to be added to or deleted from the operating procedures and maneuvers section (see 3.5.12.3.28)

## MIL-PRF-63029J

- ap. Add sections of normal procedures (see 3.5.12.6.15)
- aq. State time delay period before initiation of collective pitch control motion following a loss of power (see 3.5.13.2.2.11)
- ar. Inclusion of appendices in operator's manual. (see 3.5.16)
- as. Inclusion of an index. (see 3.5.17)
- at. Provide authentication page information. (see 3.5.18)
- au. Inclusion of warnings, cautions, and notes in operator's checklist (see 3.6.1)
- av. Provide reporting errors and recommending improvements statement (see 3.6.2.4)
- aw. Prepare a list of crewmembers' duties (see 3.6.2.5)
- ax. Use of performance data charts and the form of the charts (see 3.6.2.8.1)
- ay. Select detailed performance checks (see 3.6.2.8.2)
- az. Indicate if an operator's alternate checklist should be prepared instead of the operator's standard checklist (see 3.6.3)
- ba. Additional maintenance test flight checklist sections other than as specified (see 3.7.1)
- bb. Indicate if checklist will be different than those that are contained in the applicable aircraft operator's checklist, plus those MTF checks peculiar to the aircraft in question (see 3.7.4)
- bc. Require submission of an aerodynamic report illustrating the derivation of the data entered on the charts included in the TM (see 3.7.4)
- bd. Provide list of special/detailed procedures (see 3.7.6)
- be. Provide list of required charts, including the contents, size, and format (see 3.7.7.1)
- bf. Indicate if appendices are included (see 3.7.8)
- bg. Review, verification and acceptance requirements (see 4.2.1)
- bh. Verification plan (see 4.2.2)
- bi. Packaging requirements (see 5.1)
- bj. Indicate if change/revision update is required (see 6.4.1)
- bk. Indicate operator's manual front matter order if other than as specified (see B.3.1)

## MIL-PRF-63029J

- bl. Operator's manual identification number (see B.3.5)
- bm. Operator's manual publication date (see B.3.7)
- bn. Dimensional data are other than as specified (see B.3.11)
- bo. Include an index if other than as specified in Operator's manual (see B.3.15)
- bp. Indicate type of revision (see B.3.20)
- bq. Indicate change record requirement (see B.3.21)
- br. Indicate CL front matter order if other than as specified (see C.2.2)
- bs. Provide CL identification number (see C.2.12)
- bt. Indicate MTF front matter order if other than as specified (see D.2.2)
- bu. Indicate type of revision (see D.2.7)
- bv. Indicate MTF publication number if other than as specified (see D.2.8.6)
- bw. Use of photographic illustrations (see E.3.1.1)
- bx. Use of more than three variables if other than as specified (see E.3.2.1)
- by. Priorities for preparing graphical data that are other than as specified (see E.3.2.4)
- bz. Use of four division scale grids for graphical data presentation (see E.3.2.5.7)
- ca. Minimal minor grid spacing if other than as specified (see E.3.2.5.7)
- cb. Data range is other than as specified (see E.3.2.5.9)

6.3 Technical manuals. The requirement for technical manuals should be considered when this specification is applied on a contract. If technical manuals are required, specifications and standards that have been authorized and assigned an Acquisition Management Systems Control (AMSC) number must be listed on a separate Contract Data Requirements List (DD Form 1423), which is included as an exhibit to the contract. The technical manuals must be acquired under separate contract line item in the contract.

#### 6.4 Definitions.

6.4.1 Changes/Revisions. When updates to technical manuals are ordered the deliverable product should be change pages or a complete revision of the TM. The acquiring activity should determine the type of update required (6.2).

## MIL-PRF-63029J

6.4.2 Complete revision. A complete revision requires rewrite and reorganization of the technical content of the data. All existing changes to the basic manual should be merged. All change dates and change symbols should be removed. The total number of pages in the TM (i.e., warning page, TOC, etc.) is counted when determining the total number of pages in the proposed change and applying the percentage rule. Publications with 32 or fewer printed pages including changes should be revised when a proposed change would replace 50 percent or more of those pages. Publications with more than 32 printed pages including changes should be revised when a proposed change would replace 75 percent or more of those pages.

6.5 Terminology.

Acquiring Activity	The DoD component, activity, or organization of a using military service, or that organization delegated by a using service, that is responsible for the selection and determination of requirements for TMs.
Callout	A letter, number, or other device for identifying or calling attention to a particular part of an illustration.
Caution	Identifies and highlights an essential operating or maintenance procedure, practice, condition, statement, etc., which, if not strictly observed, could result in damage to, or destruction of, equipment or loss of mission effectiveness.
Change	A set of the corrected pages to the basic manual. It consists of information that improves or clarifies the basic manual without requiring or reorganization of the technical content of the basic manual.
Change designator	A unique number or letter used to differentiate each change page from the original pages and to differentiate among changes.
Chapter	The first major functional division of a publication.
Department of Defense (DoD)	The Office of the Secretary of Defense (OSD) (DoD) (including all boards and councils), the Military Departments (Army, Navy, and Air Force), the Organization of the Joint Chiefs of Staff (OJCS), the Unified and Specified Commands, the National Security Agency (NSA), and the Defense Agencies.
Document Type Definition (DTD)	The definition of the markup rules for a given class of documents. A DTD or reference to one should be contained in any SGML/XML conforming document.
End Item Code (EIC)	A final combination of end products, component parts, or materials that is ready for its intended use (e.g., tank, mobile machine ship, aircraft, receiver, rifle, recorder).
Equipment Publication	A publication that deals with the installation, operation, maintenance, training, and parts supported of Army materiel, including firing tables (FTs), Equipment technical manuals (TMs), technical bulletins (TBs), and modification work orders (MWOs) are examples of DA publications media used to provide these essential instructions.

## MIL-PRF-63029J

Extensible Markup Language (XML)	A subset SGML. It enables generic SGML to be served, received, and processed on the Web in the way that is now possible with HTML. XML has been designed for ease of implementation and for interoperability with both SGML and HTML.
Final reproducible copy	The final approved manuscript (or reproducible copy) with illustrations ready for printing and distribution as a DA equipment publication.
Foldout page	A page the same height as, but is wider than, a standard page. Foldout pages are folded 2, 4 or 6 times (depending on width) to assume the dimensions of a standard page.
Icon	Pictorial images which may be used in lieu of words. For example: the icon is used to represent "Electrostatic Discharge Sensitive." See MIL-STD-40051-1 and -2 for authorized icons.
Illustration	A general term meaning graphic presentations of all types. Illustrations include pictorials, functional diagrams, and line graphs. This term is used synonymously with figure, graphic, drawing, diagram, and artwork.
Key	A tabular listing of the callout or item numbers/letters and their meanings.
Leader lines	A line with or without arrowhead extending from index number or letter/nomenclature to item.
Leading	The vertical spacing between lines of type measured from baseline to baseline (bottom of line to bottom of next line below). Leading is measured in points.
Legend	Explanatory matter on a map, chart, illustration or the like, listing and explaining the symbols or other information used.
National Stock Number (NSN)	13-digit number assigned to a repair part to be used for requisitioning purposes.
Nomenclature	The approved name or alphanumeric identifier assigned to an item, equipment, or component in agreement with an organized designation system.
Note	Identifies and highlights an essential operating or maintenance procedure, condition, or statement.
Page-based technical Manual	A technical manual consisting of text, illustrations, and tabular data presented in a standard page-oriented format.
Part	The next lower division of a publication below volume. Parts should normally be separately bound.
Placard	Item names shown on controls, switches, panels, etc.
Revision	A second or subsequent edition of a manual which normally supersedes the preceding edition. A revision is necessary when more than 75% of the data is being changed.
Section	The first major functional subdivision of a chapter.

## MIL-PRF-63029J

Set	A number of individual manuals or volumes which comprises a complete TM package of information for an item.
Standard technical manual	Any TM that does not require a new concept or special presentation of data that cannot, or should not, be constrained by the size and format requirements of this specification.
Standard Generalized Markup Language (SGML)	A language for document representation that formalizes markup and frees it of system and processing dependencies.
Supplement	A complimentary TM which supplements information in a related TM.
System	A group of items united or regulated by interaction or interdependence to accomplish a set of specific functions.
Technical manual	A manual that contains instructions for the installation, operation, maintenance, and support of weapon systems, weapon system components, and support equipment. TM information may be presented, according to prior agreement between the contractor and the Government, in any form or characteristic, including hard printed copy, audio and visual displays, electronic embedded media, disks, other electronic devices, or other media. They normally include operational and maintenance instructions, parts lists, and related technical information or procedures exclusive of administrative procedures.
Title Block Page	The first page after the warning summary in the front matter portion of a TM. It identifies the TM by publication number, date, title, and NSN/part number/model of equipment covered in the manual.
Validation	The process by which a contractor (or other agency, as directed by the contracting activity) tests a technical publication for completeness, compliance with contractual requirements, and technical accuracy. It is conducted at the contractor's facility or at the operational site, and entails the actual performance of operating and maintenance procedures on the equipment for which the publication was written. Data such as stock/part numbers and SMR codes in RPSTL, hardware depiction, schematic diagrams, and wiring data contained in the publication are checked against current source data.

## MIL-PRF-63029J

Verification	The process by which an equipment publication is tested for completeness, accuracy, and adequacy of content, and usability by government personnel (not contractors) against the production configurations of the related system or equipment. The proponent's technical publications element will be responsible for ensuring all technical and equipment publications are fully verified; no publications will be submitted for authentication until they have been fully verified and proved (under Army or other DoD component jurisdiction) to be adequate (comprehensive and usable) for the operation and maintenance of equipment procured for operational units.
Volume	The first separately bound subdivision of a publication.
Warning	Identifies and highlights an essential operating or maintenance procedure, practice, condition, statement, etc., which if not strictly observed, could result in injury to, or death of, personnel or long term health hazards to the person performing that procedure.
XML Stylesheet Language (XSL)	A language for transforming XML documents into other XML documents, such as HTML.



## MIL-PRF-63029J

6.6 Acronyms used in this specification.

AV	air vehicle
CG	center-of-gravity
CL	Checklist
DA	Department of the Army
DoD	Department of Defense
DTD	document type definition
EIC	end item code
FAT	free air temperature
FOSI	formatted output specification instance
IAS	indicated airspeed
IMC	instrument meteorological conditions
IMN	indicated Mach number
KIAS	knots indicated airspeed
MFD	multifunction display
MTF	Maintenance Test Flight
NSN	national stock number
ODC	ozone depleting chemicals
rpm	revolution per minute
SGML	Standard Generalized Markup Language
TEC	entire analysis check
TM	technical manual
TOC	table of contents
UAS	Unmanned Aircraft Systems
XML	eXtensible Markup Language
XSL	XML Stylesheet Language

6.7 Subject term (key word) listing.

Avionics	Page, warning
Center-of-gravity (CG)	Procedures, emergency
Checklist, alternate	Procedures, normal
Checklist, standard	Statement, distribution
Condition heading	Symbol, designator
Cover	System, flight control
Data, graphical	System, hydraulic
Data, performance	System, power train
Diagram, moment	System, utility
Equipment, mission	Test flight, maintenance
Instruments, flight	Through-flight
Limits, operating	Weight and balance
Number, publication	

6.8 Changes from previous issue. Marginal notations are not used in this revision to identify changes with respect to the previous issue due to the extent of the changes.

MIL-PRF-63029J

For multi-volume TMs  
 For single-volume TMs → \* **TM 1-1520-240-10**  
 Supersedes TM 1-1520-240-10 dated 01 May 2000

---

**TECHNICAL MANUAL  
 OPERATOR'S MANUAL  
 FOR  
 ARMY CH-47D  
 HELICOPTER  
 (NSN 1520-01-088-240) (EIC: RCD)**

This manual is incomplete without volumes 2 and 3.

**WARNING** - This document contains technical data whose export is restricted by the Arms Export Control Act (Title 22, U.S.C. SEC 2751, et seq.) or the Export Administration Act of 1979, as amended, Title 50, U.S.C., App. 2401 et. seq. Violations of these export laws are subject to severe criminal penalties. Disseminate in accordance with provisions of DoD Directive 5230.25.

**DISTRIBUTION STATEMENT C:** Distribution authorized to U.S. Government agencies and their contractors only to protect technical or operational information from automatic dissemination under the International Exchange Program or by other means. This protection applies to the publications required solely for official use and to those containing valuable technical or operational information. This determination was made on 16 June 2006. Other requests for this document will be referred to Commander, US Army Aviation and Missile Command, PEO Aviation, ATTN: SFAE-AV-CH-L, Redstone Arsenal, AL 35898-5000.

**DESTRUCTION NOTICE** - Destroy by any method that will prevent disclosure of contents or reconstruction of the document.

Disclosure Notice

\* This manual supersedes TM 1-1520-240-10, 31 January 2003, including all changes.

For multi-volume TMs → **HEADQUARTERS, DEPARTMENT OF THE ARMY  
 16 JUNE 2006**

FIGURE 1. Example of front cover (reduced in size to fit on page)

## MIL-PRF-63029J

## TM 1-1520-123-10

Personnel performing operations, procedures, and practices which are included or implied in this technical manual shall observe the following warnings. Disregard of these warnings and precautionary information can cause serious injury or death.

**WARNING**

Refer to FM 4-25.11 for first aid data.

**WARNING**

Personnel performing operations, procedures, and practices which are included or implied in this technical manual shall observe the following warnings. Disregard of these warnings and precautionary information can cause serious injury or loss of life.

**WARNING****AVIATION LIFE SUPPORT EQUIPMENT**

Aviation life support equipment shall be utilized in accordance with and . Failure to do so may result in personal injury or loss of life.

**WARNING****BATTERY ELECTROLYTE**

Battery electrolyte is harmful to the skin and clothing. Neutralize any spilled electrolyte by thoroughly flushing contacted area with water.

**WARNING****CANOPY JETTISON**

Canopy jettison safety pins shall be installed in pilot, copilot/gunner, and external firing mechanisms when the helicopter is on the ground. The canopy jettison system is manually operated. The canopy can be jettisoned when no electrical power is on the helicopter. Pilot and copilot/gunner safety pins shall be removed before starting engines. Safety pins shall be installed during engine shutdown check. Debris may be expelled 50 feet outward when system is actuated. Pilot and copilot/gunner helmet visor should be down to prevent eye injury.

**WARNING****CARBON MONOXIDE**

When smoke, suspected carbon monoxide fumes, or symptoms of anoxia exist, the crew should immediately ventilate the cockpit.

**WARNING****ELECTROMAGNETIC INTERFERENCE (EMI)**

No electrical/electronic devices of any sort, other than those described in this manual or appropriate maintenance manuals, are to be operated by crew members during operation of this helicopter. The aircraft may experience equipment performance anomalies when flying in the vicinity of High Intensity Radio Transmission Areas (HIRTAs); accordingly, aircraft flights, whether day or night, shall use night stand-off distances in accordance with HIRTA messages. Contact email: ae-d-ts@amrdec.army.mil to obtain information on the most current AH-64 (HIRTA) messages.

Even when in compliance with the above paragraph, erratic behavior of these systems (communication, navigation, display and weapons) may occur when operating in and around high-powered radio and radar transmitters.

a

**FIGURE 2. Example of a warning page (reduced in size to fit on page)**

## MIL-PRF-63029J

TM 1-1520-123-10

CHANGE  
NO. 1HEADQUARTERS  
DEPARTMENT OF THE ARMY  
10 October 2011TECHNICAL MANUAL  
OPERATOR'S MANUAL  
FOR

HELICOPTER

UH-1

(NSN 1520-01-088-1234)

(EIC: ABC)

**OZONE DEPLETING CHEMICALS INFORMATION**

This document has been reviewed for the presence of Class I Ozone Depleting Chemicals. As of provided date, the status is: All references to Class I Ozone Depleting Chemicals have been removed from this document by substitution with chemicals that do not cause atmospheric ozone depletion.

**WARNING** - This document contains technical data whose export is restricted by the Arms Export Control Act (Title 22, U.S.C. SEC 2751, et seq.) or the Export Administration Act of 1979, as amended, Title 50, U.S.C., App. 2401 et. seq. Violations of these export laws are subject to severe criminal penalties. Disseminate in accordance with provisions of DoD Directive 5230.25.

**DISTRIBUTION STATEMENT C:** Distribution authorized to U.S. Government agencies and their contractors only to protect technical or operational information from automatic dissemination under the International Exchange Program or by other means. This protection applies to the publications required solely for official use and those containing valuable technical or operational information. This determination was made in July 2003. Other requests for this document will be referred to Commander, U.S. Army Technology Applications Program Office (TAPO), ATTN: AMSAM-AR-Z-A-TL, Building 401 Lee Avenue, Fort Eustis, Virginia 23604-5577. You may fax your request to (757) 878-3937 or DSN 927-3937.

**DESTRUCTION NOTICE** - Destroy by any method that will prevent disclosure of contents or reconstruction of the document.

TM 1-1520-123-10, 16 June 2009, is changed as follows:

1. The pages affected by this change, appearing in the following listing, are to be inserted into the TM. New or changed text is indicated by a vertical bar in the margin of the page. Where a completed paragraph, chapter, section or appendix is changed or added, a vertical line is placed in the margin by the title only. Changes to illustrations are indicated by miniature pointing hands.

Remove Pages	Insert Pages
A-B	A-B
2-15 thru 2-22	2-15 thru 2-22
3-5 and 3-6	3-5 and 3-6
-----	4-2.1 thru 4-2.8
5-55 and 5-56	-----

2. File this change sheet in front of the publication for reference purposes.

**FIGURE 3. Example of a change transmittal page (Reduced in size to fit on page)**

## MIL-PRF-63029J

TM 1-1520-272-10-1

## LIST OF EFFECTIVE PAGES

Insert the latest changed pages in accordance with the instructions on the transmittal sheet.

NOTE: On a changed page, the portion of the text affected by the latest change is indicated by a vertical line in the outer margin of the page. Changes to illustrations are indicated by a letter suffix adjacent to the identification number. Added or completely revised chapters, sections, paragraphs, tables, etc., are indicated by a vertical line by the title.

Dates of issue for original and change pages are:

Original ..... 17 February 2009                      Change 1 ..... XX XXX XXXX

TOTAL NUMBER OF PAGES IN THIS PUBLICATION IS 1346, CONSISTING OF THE FOLLOWING:

Page No.	*Change No.	Page No.	*Change No.
Cover	0	xxvii	0
a	0	xxviii	0
b	0	1-1	0
A	0	1-2	0
B	0	2-1	0
C	0	2-2	0
D	0	2-3	0
E	0	2-4	0
F	0	2-5	0
G	0	2-6	0
H	0	2-7	0
I	0	2-8	0
J	0	2-9	0
K	0	2-10	0
L	0	2-11	0
i	0	2-12	0
ii	0	2-13	0
iii	0	2-14	0
iv	1	2-15	0
v	1	2-16	0
vi	0	2-17	0
vii	0	2-18	0
viii	0	2-19	0
ix	0	2-20	0
x	0	2-21	0
xi	0	2-22	0
xii	0	2-23	0
xiii	0	2-24	0
xiv	0	2-25	0
xv	0	2-26	0
xvi	0	2-27	0
xvii	0	2-28	0
xviii	0	2-29	1
xix	0	2-30	1
xx	0	2-31	0
xxi	0	2-32	0
xxii	0	2-33	0
xxiii	0	2-34	0
xxiv	0	2-35	0
xxv	1	2-36	0
xxvi	1	2-37	0

\*Zero in this column indicates an original page.

A

FIGURE 4. List of effective pages (reduced in size to fit on page)

MIL-PRF-63029J

\* TM1-1520-272-10-1

TECHNICAL MANUAL  
1-1520-272-10-1

HEADQUARTERS  
DEPARTMENT OF THE ARMY  
WASHINGTON, D.C. 17 February 2009

OPERATOR'S MANUAL  
FOR  
MH-47G HELICOPTER (EIC: N/A)

**REPORTING ERRORS AND RECOMMENDING IMPROVEMENTS**

You can improve this manual. If you find any mistakes, or if you know of a way to improve these procedures, please let us know. Mail your letter or DA Form 2028 (Recommended Changes to Publications and Blank Forms), located in the back of this manual, directly to: Commander, U.S. Army Aviation and Missile Command, ATTN: AMSAM-MMC-MA-NP, Redstone Arsenal, AL 35898-5230. You may also submit your recommended changes by e-mail directly to [2028@redstone.army.mil](mailto:2028@redstone.army.mil) or by fax (256) 842-6546/DSN 788-6546. A reply will be furnished to you. Instructions for sending an electronic 2028 may be found at the back of this manual immediately preceding the hard copy 2028. For the World Wide Web use: <https://amcom2028.redstone.army.mil>.

**DISTRIBUTION STATEMENT C:** Distribution authorized to U.S. Government agencies and their contractors only to protect technical or operational information from automatic dissemination under the International Exchange Program or by other means. This protection applies to the publications required solely for official use and those containing valuable technical or operational information. This determination was made in July 2003. Other requests for this document will be referred to Commander, U.S. Army Technology Applications Program Office (TAPO), ATTN: AM-SAM-AR-Z-A-TL, Building 401 Lee Avenue, Fort Eustis, Virginia 23604-5577. You may fax your request to (757) 878-3937 or DSN 927-3937.

**DESTRUCTION NOTICE** - Destroy by any method that will prevent disclosure of contents or reconstruction of the document.

**TABLE OF CONTENTS**

	Page
VOLUME 1	
CHAPTER 1 INTRODUCTION .....	1-1
CHAPTER 2 AIRCRAFT AND SYSTEMS DESCRIPTION AND OPERATION .....	2-1
Section I Aircraft .....	2-1
Section II Common Avionics Architecture System (CAAS) .....	2-15
Section III Emergency Equipment .....	2-33
Section IV Engines and Related Systems .....	2-36
Section V Fuel System .....	2-58
Section VI Flight Controls .....	2-67
Section VII Hydraulic Systems .....	2-80
Section VIII Power Train System .....	2-84
Section IX Rotor System .....	2-87
Section X Utility Systems .....	2-89
Section XI Heating, Ventilation, Cooling, and Environmental Control Systems .....	2-94.1
Section XI Heating, Ventilation, Cooling, and Environmental Control Systems .....	2-94.1

\* This manual supersedes TM 1-1520-272-10-1, dated 06 April 2007, including all changes.

**FIGURE 5. Abbreviated title page w/table of contents (Reduced in size to fit on page)**

MIL-PRF-63029J

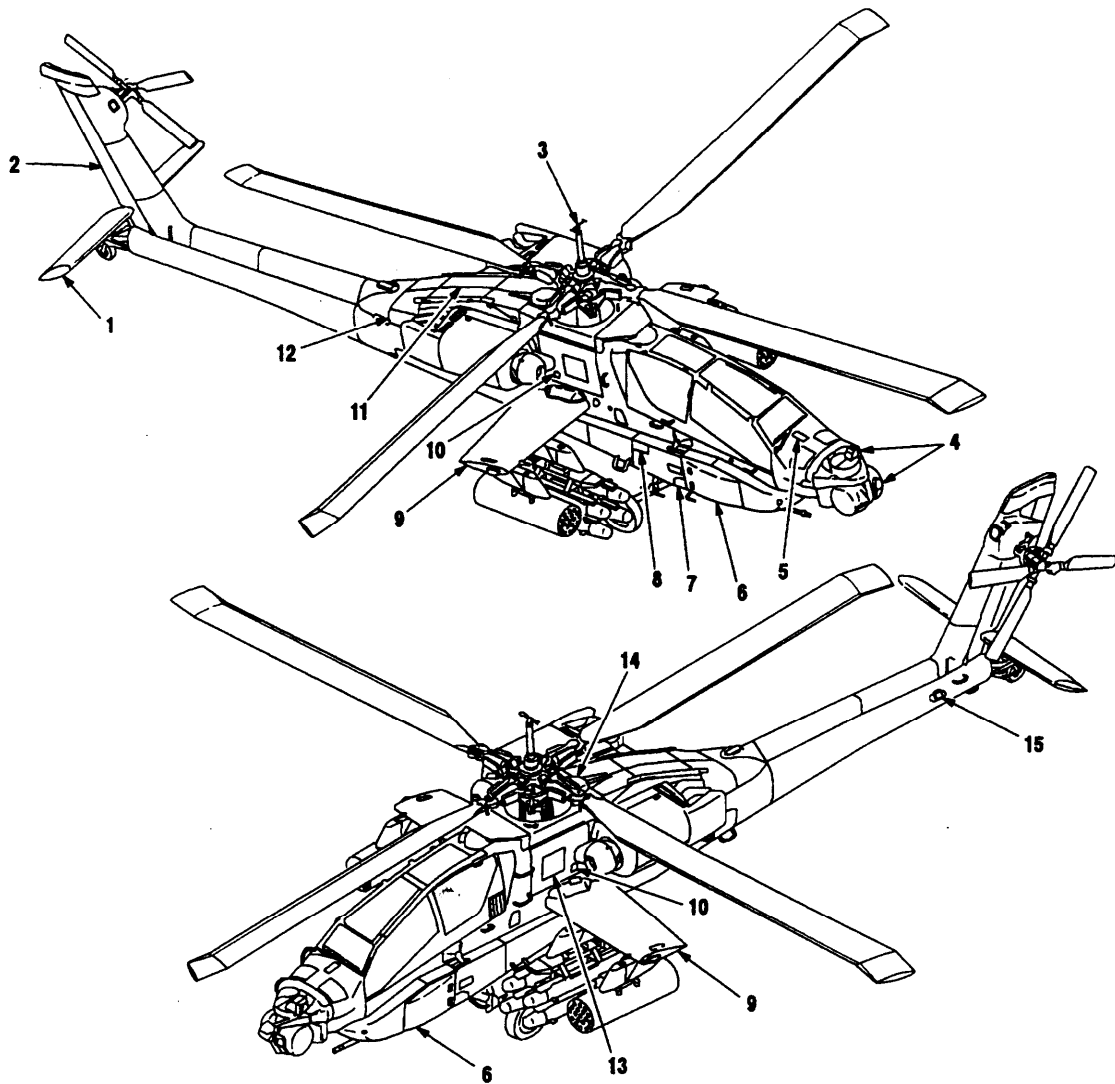

- |  |  |
|--|--|
| 1. STABILATOR                              | 9. INTERCOMM ACCESS DOOR                               |
| 2. VERTICAL STABILIZER                     | 10. MAIN TRANSMISSION OIL LEVEL SIGHT GAGE ACCESS DOOR |
| 3. AIR DATA SENSOR                         | 11. AFT EQUIPMENT BAY (CATWALK AREA) ACCESS DOORS      |
| 4. TADS & PNVIS TURRETS                    | 12. HYDRQULIC GROUND SERVICE PANEL ACCESS DOOR         |
| 5. CANOPY JETTISON HANDLE DOOR ACCESS DOOR | 13. HYDRAULIC OIL LEVEL SIGHT GAGE ACCESS DOOR         |
| 6. FORWARD AVIONICS BAY ACCESS DOOR        | 14. INFRARED COUNTERMEASURE DEVICE MOUNT               |
| 7. MOORING LUG ACCESS DOOR                 | 15. CHAFF PAYLOAD MODULE MOUNT                         |
| 8. FIRE EXTINGUISHER ACCESS DOOR           |  |

**FIGURE 6. Aircraft general arrangement diagram (sheet 1 of 2)**

MIL-PRF-63029J

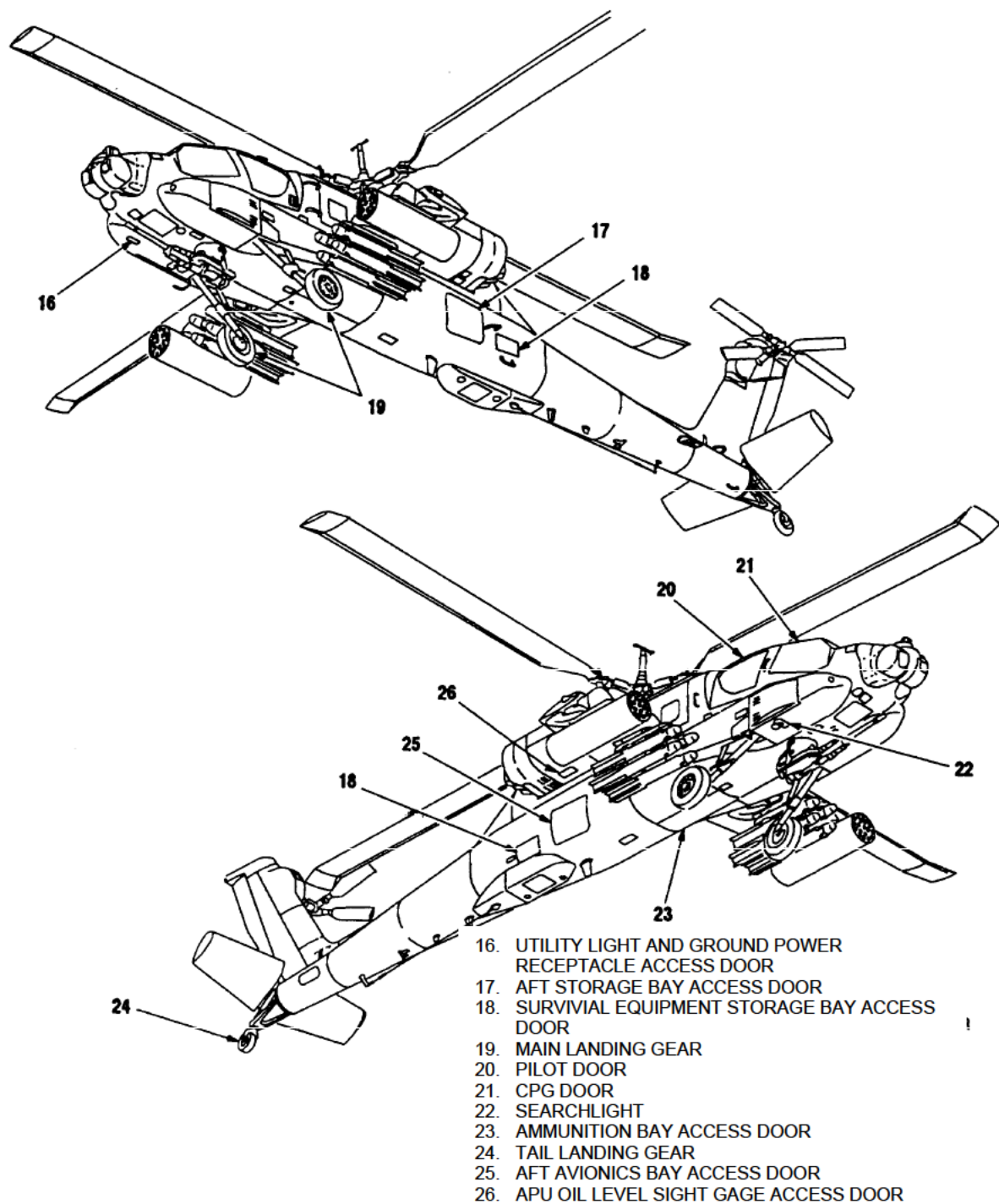

FIGURE 6. Aircraft general arrangement diagram (sheet 2 of 2)



MIL-PRF-63029J

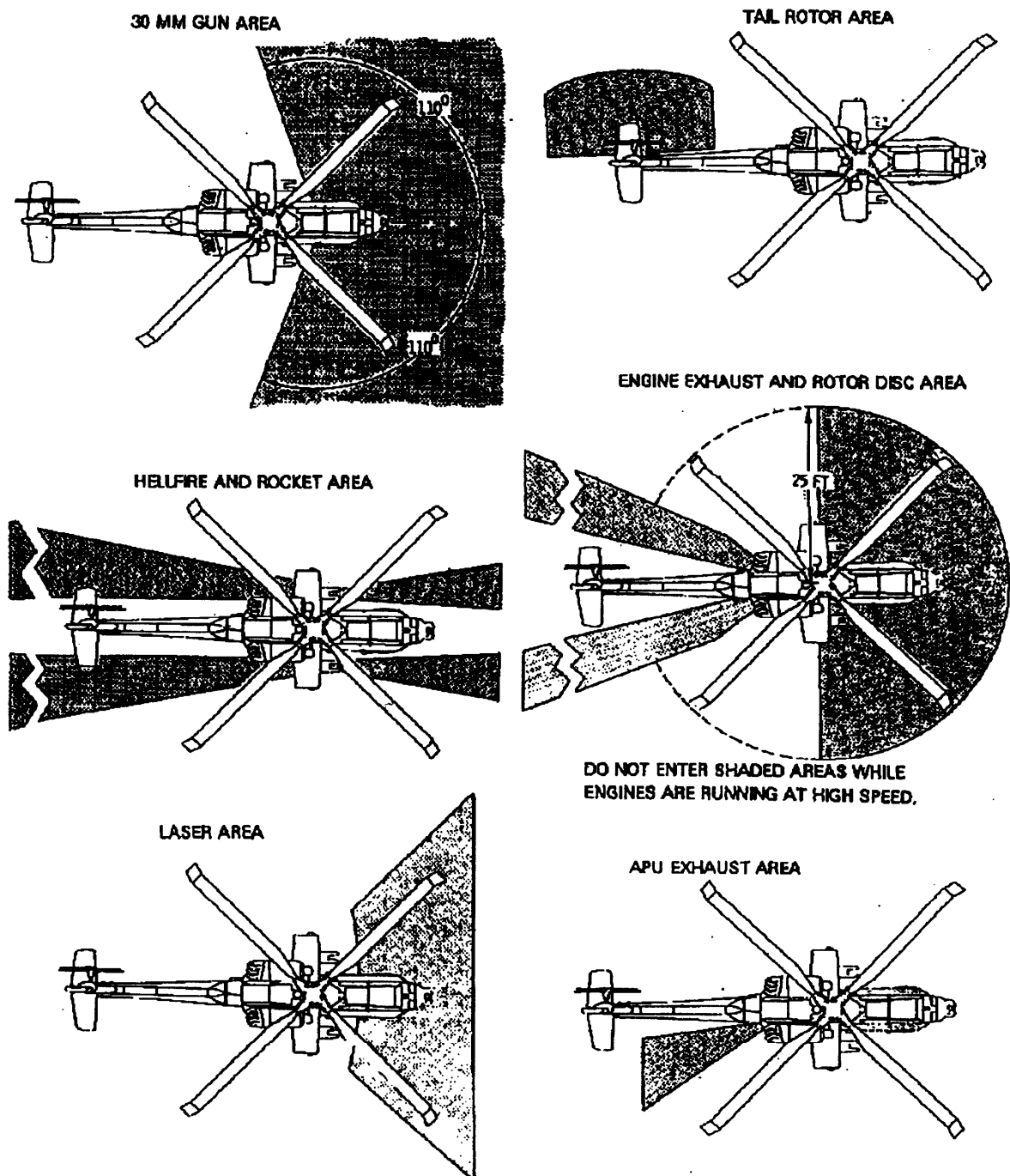

FIGURE 7. Example of danger area diagram

MIL-PRF-63029J

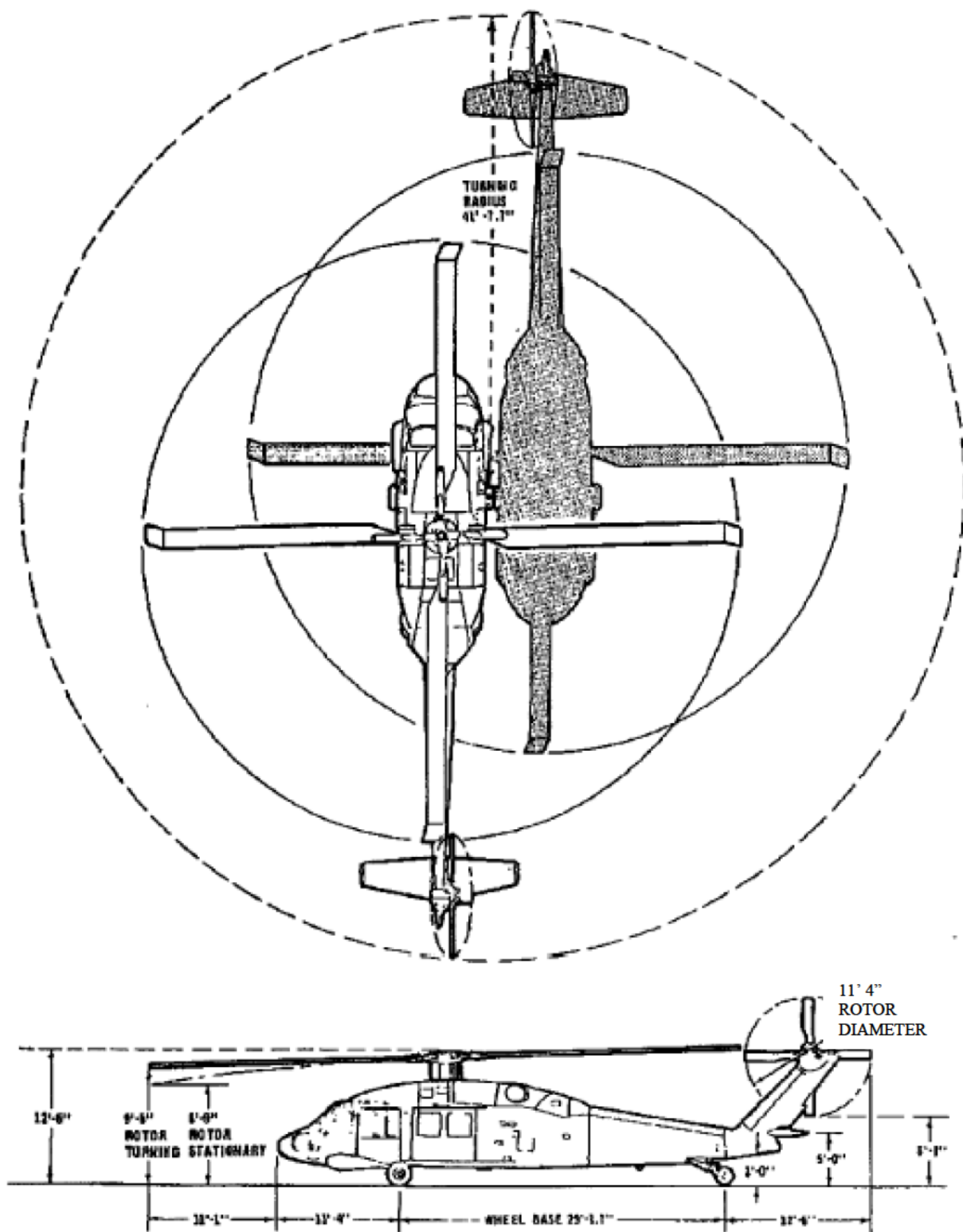

FIGURE 8. Example of turning radius and dimensions diagram

## MIL-PRF-63029J

Table 2-1. Main Differences

ITEM	RU-21E	RU-21H
Maximum takeoff gross weight	9,650 pounds Special equipment operators (2)	10,200 pounds
Maximum landing weight	9,168 pounds	9,700 pounds
Wing span	45 ft 10.5 in	50 ft 8 in
Minimum ground turning radius	29 ft 8.75 in	31 ft 11 in
Mission antennas	Fixed type  None	Fixed type plus two retractable belly-mounted mission antennas  Mission antennas deice boots
Fuel system	Four quantity indicator gages installed	Two quantity indicator gages installed
Emergency equipment	Four first aid kits installed	Two first aid kits installed
Oxygen system	Two 64 cubic foot cylinders servicing pilot, copilot, and two operator stations	Four 64 cubic foot cylinders servicing pilot and copilot, and provisions for two personnel in cabin area
Communications	Audio control panel C-1611/AIC (four installed)  FM liaison set AN/ARC-131 (two installed)  Voice security TSEC/KY-28 (two installed, one for pilot and copilot and one for mission operators)  HF command set	Audio control panel C-1611/AIC (two installed)  FM liaison set AN/ARC-131 (one installed)  Voice security TSEC/KY-28 (two installed, one used with FM and one with UHF)  Complete provisions only
Crew	Minimum crew normal mission: two pilots and two operators	Minimum crew normal mission: two pilots
Miscellaneous equipment	Plotting board behind pilot's seat  Rack for M-16 rifles  Shock mounted racks both sides of cabin	None  None  Shock mounted racks on right side of cabin

FIGURE 9. Example of main differences table

MIL-PRF-63029J

TM 1-16XX-XXX-10

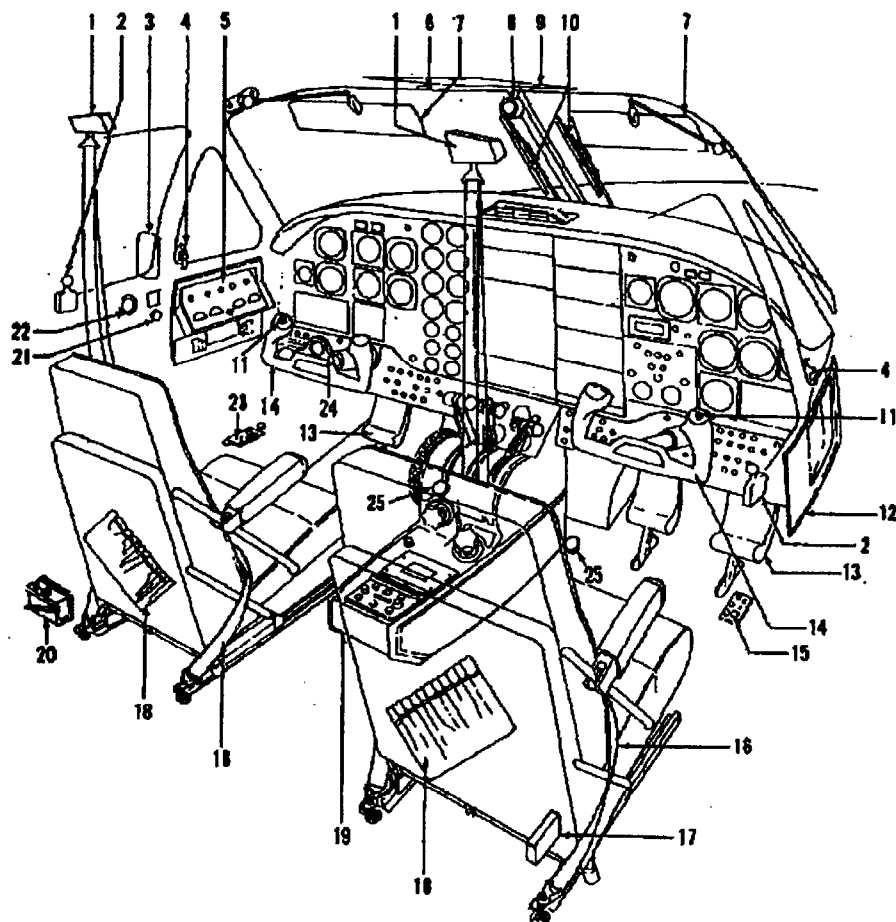

- |                                      |  |
|--------------------------------------|--|
| 1. Shoulder harness inertia reel     | 14. Control wheel                                      |
| 2. Shoulder harness lock lever       | 15. Oxygen regulator control panel                     |
| 3. External rear view mirror         | 16. Seat belt  |
| 4. Storm window lock                 | 17. Vertical gyro circuit breaker box                  |
| 5. Fuel management panel             | 18. Utility pocket                                     |
| 6. Free air temperature gage         | 19. Control pedestal                                   |
| 7. Sun visor                         | 20. Audio control panel                                |
| 8. Magnetic compass                  | 21. External mirror adjustment knob                    |
| 9. Overhead control panel            | 22. Oxygen system gage                                 |
| 10. Windshield wipers                | 23. Oxygen system controls and regulator control panel |
| 11. Microphone switch                | 24. Eight-day clock                                    |
| 12. Co-pilot's circuit breaker panel | 25. Foot microphone switch                             |
| 13. Rudder pedals                    |  |

FIGURE 10. Compartments

MIL-PRF-63029J

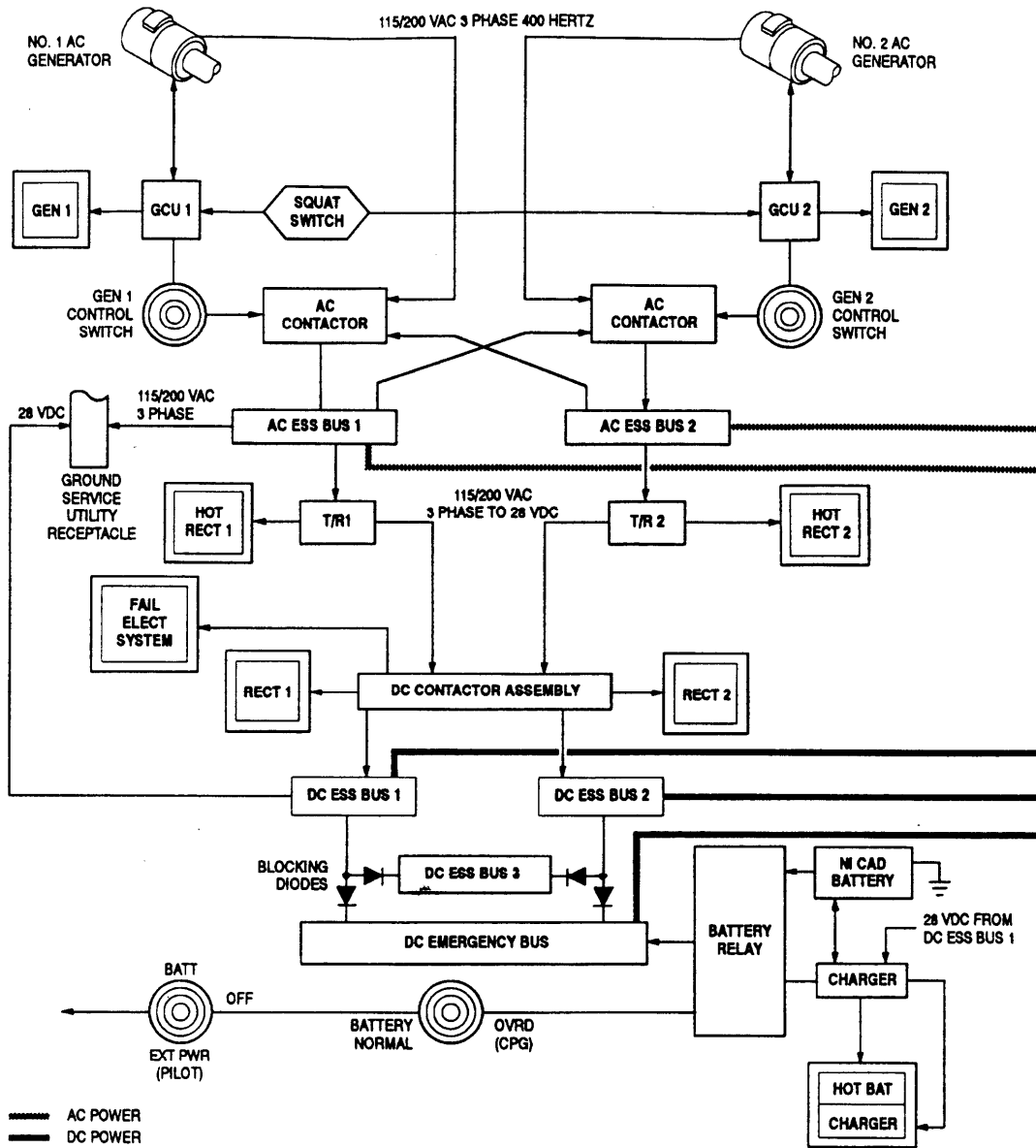

FIGURE 11. Example of electrical power supply and distribution system (sheet 1 of 2)

## MIL-PRF-63029J

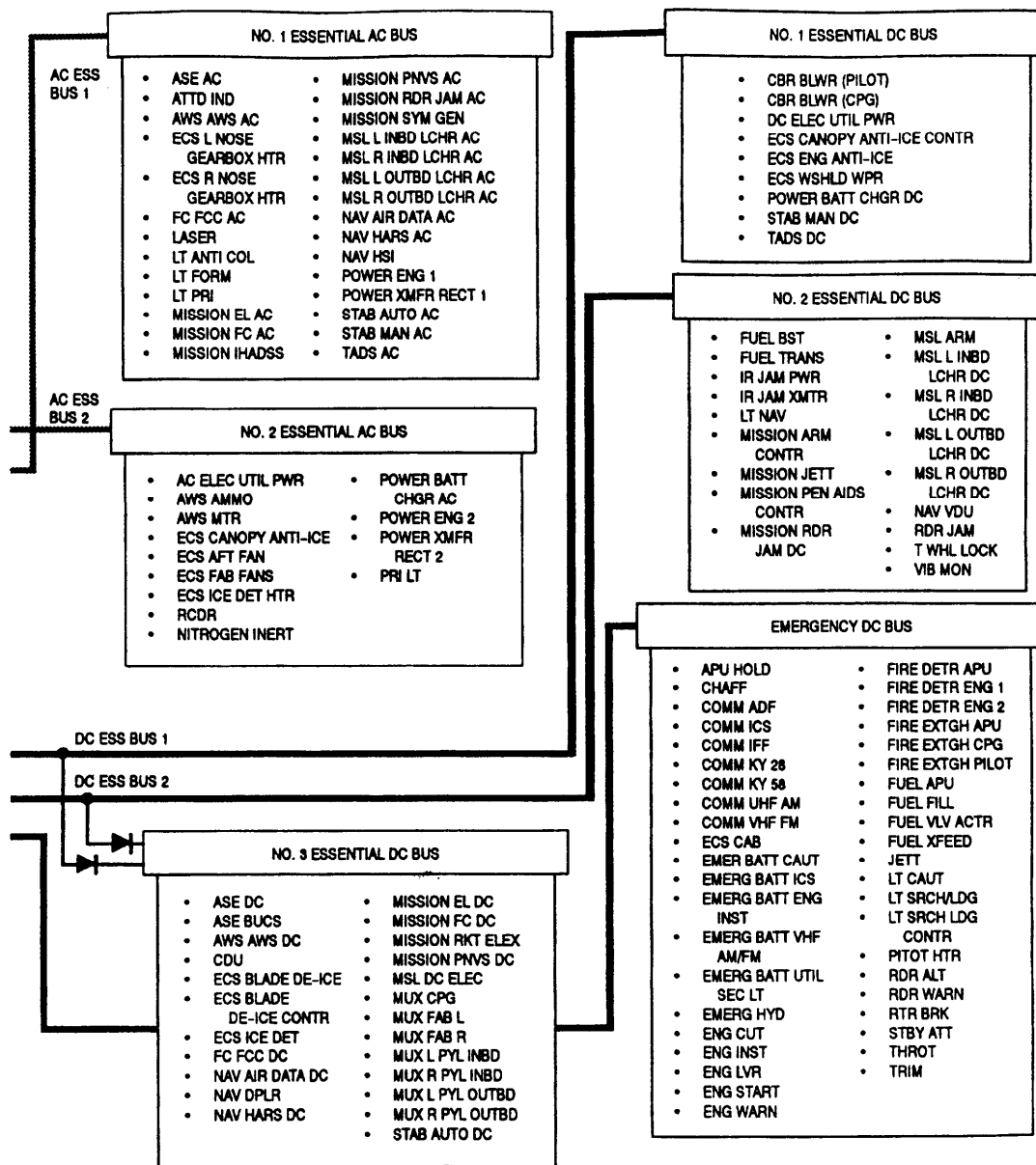
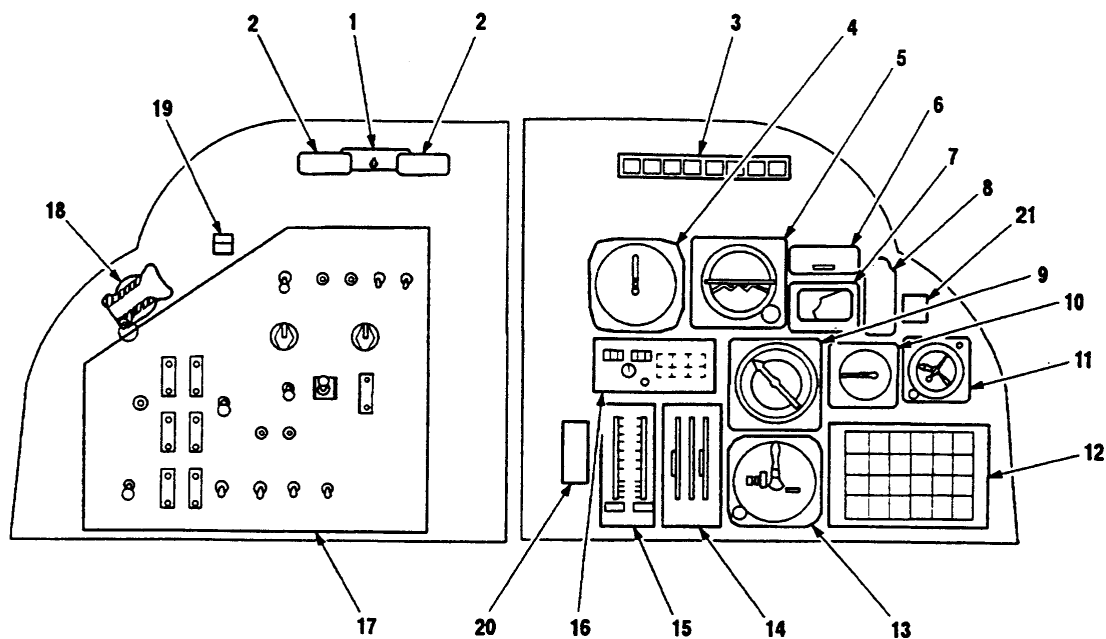

FIGURE 11. Example of electrical power supply and distribution system (sheet 2 of 2)

## MIL-PRF-63029J



1. FIRE EXTINGUISHER BOTTLE SELECT SWITCH
2. ENGINE FIRE PULL HANDLES
3. MASTER CONTROL WARNING PANEL
4. AIRSPEED INDICATOR
5. REMOTE ATTITUDE INDICATOR
6. RADIO CALL PLACARD
7. STABILATOR POSITION INDICATOR
8. STABILATOR / AIRSPEED PLACARD
9. RADIO MAGNET INDICATOR (RMI)
10. VERTICAL SPEED INDICATOR (VSI)
11. CLOCK
12. CAUTION / WARNING PANEL
13. BAROMETRIC ALTIMETER
14. ENGINE ROTOR INDICATOR
15. ENGINE TORQUE INDICATOR
16. SELECTABLE DIGITAL DISPLAY PANEL
17. FIRE CONTROL PANEL
18. CANOPY JETTISON HANDLE
19. ARM SAFE INDICATOR
20. ENGINE INSTRUMENT DIM / TEST PANEL
21. FUEL TRANSFER INDICATOR  
(UNMODIFIED CAUTION / WARNING  
PANEL)

**FIGURE 12. Instrument panel**

## MIL-PRF-63029J

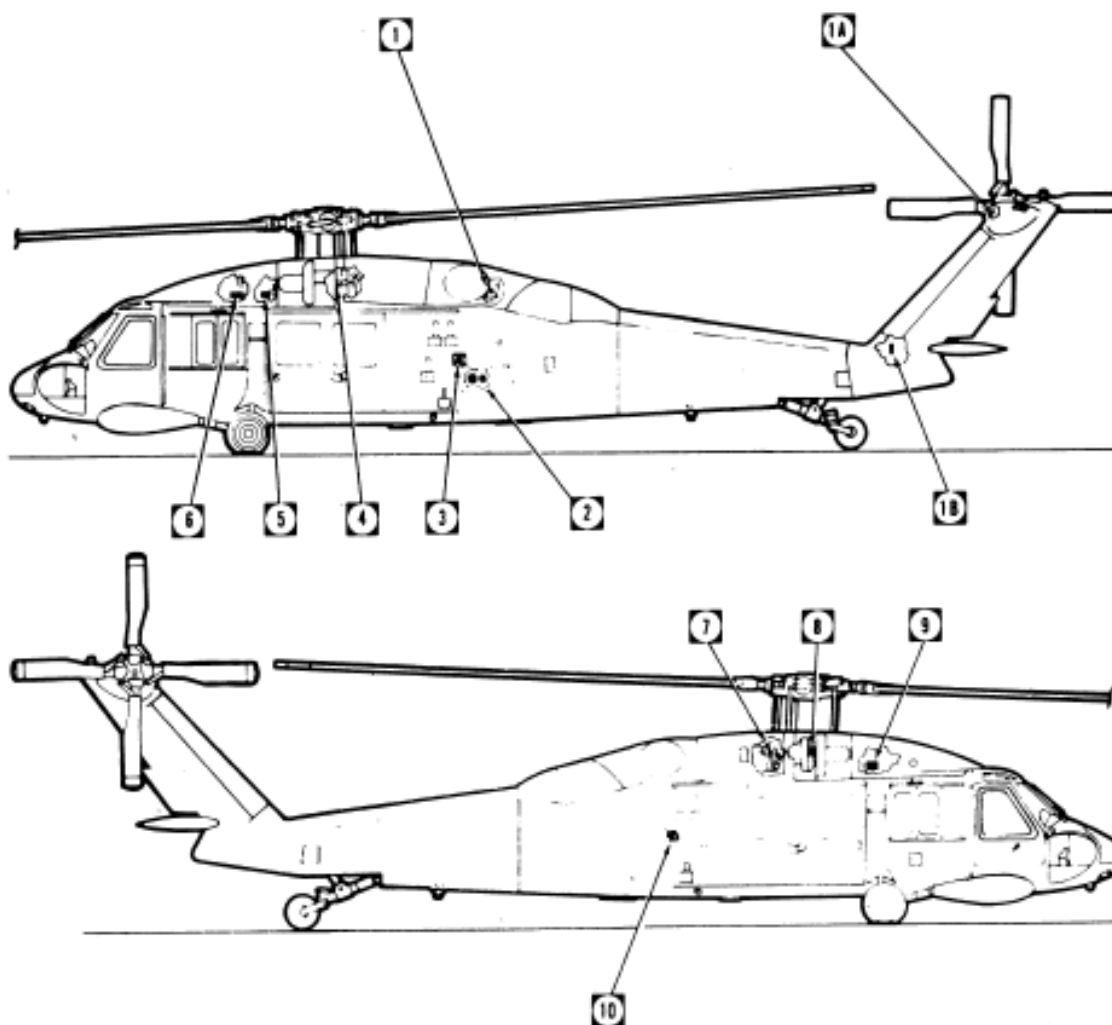

1. AUXILIARY POWER UNIT
- 1A. TAIL ROTOR GEAR BOX OIL LEVEL SIGHT GAGE
- 1B. INTERMEDIATE GEAR BOX OIL LEVEL SIGHT GAGE
2. CLOSED CIRCUIT AND PRESSURE REFUELING PORTS
3. NO. 1 (LEFT) FUEL TANK GRAVITY REFUEL PORT
4. NO. 1 ENGINE OIL LEVEL SIGHT GAGE
5. NO. 1 HYDRAULIC PUMP MODULE
6. BACKUP HYDRAULIC PUMP MODULE
7. MAIN TRANSMISSION OIL FILLER PORT AND DIP STICK
8. NO. 2 ENGINE OIL FILLER PORT AND SIGHT GAGE
9. NO. 2 HYDRAULIC PUMP MODULE AND PUMP MODULE FLUID FILLER PUMP
10. NO. 2 (RIGHT) FUEL TANK GRAVITY REFUEL PORT

**FIGURE 13. Servicing diagram (sheet 1 of 2)**



MIL-PRF-63029J

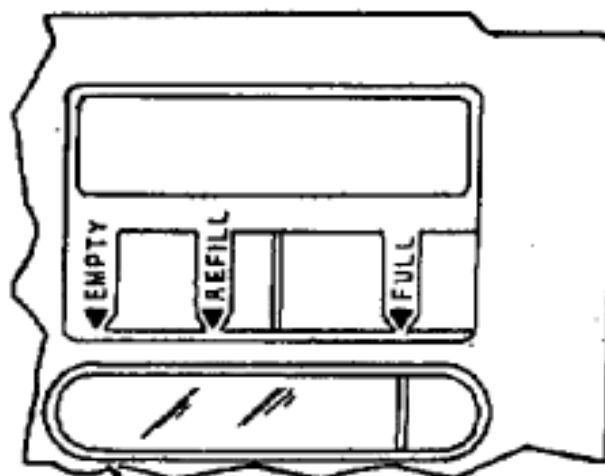
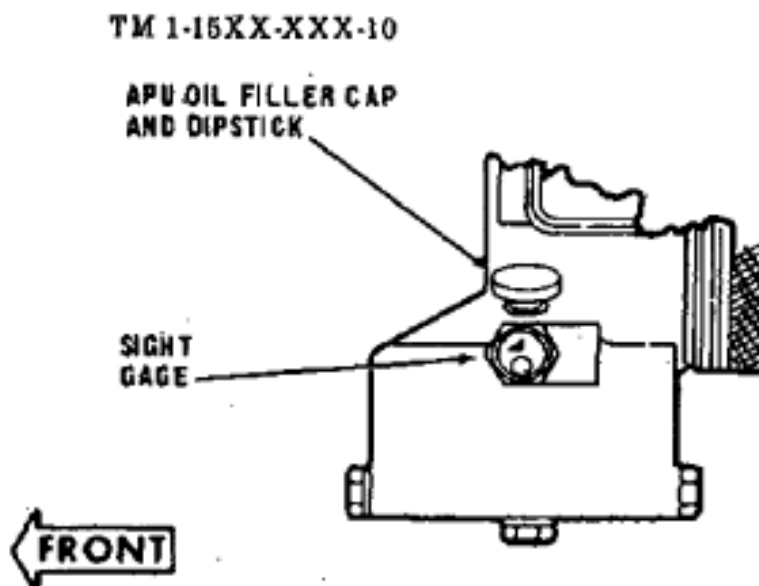

NO. 2 AND BACKUP  
HYDRAULIC PUMP MODULES  
FWD LEVEL INDICATOR

FIGURE 13. Servicing diagram (sheet 2 of 2)

## MIL-PRF-63029J

## Servicing Table of Approved Fuels, Oils, and Fluids

System	Specification
Fuel.....	MIL-DTL-5624 (JP-4) 1
Crashworthy System	
Total 208.5 U.S. gallons (789.2 liters)	
Usable 206.5 U.S. gallons (781.6 Liters)	
Internal Auxiliary Tanks-	
Usable 300 U.S. gallons (1135.5 liters)	
Oil	
Engine.....	**MIL-PRF-23699 3,4 *MIL-PRF-7808 2,4
Transmisión.....	**MIL-PRF-23699 3,4 *MIL-PRF-7808 2,4
42 Gearbox.....	**MIL-PRF-23699 3,4 *MIL-PRF-7808 2,4
90 Gearbox.....	**MIL-PRF-23699 3,4 *MIL-PRF-7808 2,4
Hydraulic System.....	
Main Rotor Grip.....	MIL-PRF-83282 5 A-A-52039 6,7 **MIL-PRF-23699 3,4,6 *MIL-PRF-7808 2,4 MIL-PRF-2104 6,7 MIL-PRF-46167 6,7
Pillow Block Oil.....	**MIL-PRF-23699 3,4 *MIL-PRF-7808 2,4 MIL-PRF-2104 6,7 A-A-52039 6,7 MIL-PRF-46167 6,7

## FOOTNOTES

<sup>1</sup> Army Standard fuel is MIL-DTL-5624 (JP-4) NATO code is F-40. Alternate fuels are MIL-DTL-5624 (JP-5) (NATO F-44) and MIL-DTL-83133 (JP-8) (NATO F-34). Emergency fuel is ASTM D910 (any AV gas) (NATO F-12, F-18, F-22). Refer to TM 55-9150-200-24.

The helicopter shall not be flown when emergency fuel has been used for a total cumulative time of 50 hours. (25 hours when TCP is used in fuel.)

## CAUTION

\* Lubrication oil made to MIL-PRF-7808 by Shell Oil Company under their part number 307, qualification number 7D-1 shall not be used in the engine or aircraft systems. It contains additives which are harmful to seals in the systems.

<sup>2</sup> MIL-PRF-7808 NATO code is 0-148. For use in ambient temperatures below minus 32 C/25 F. May be used when MIL-PRF-23699 oil is not available. Not for use in main rotor hub P/N 204-012-101-31.

## CAUTION

\*\* Under no circumstances shall MIL-PRF-23699 oil be used in ambient temperatures below minus 32 C/25 F.

<sup>3</sup> MIL-PRF-23699 NATO code is 0-156. For use in ambient temperature above minus 32 C/25 F. Not for use in main rotor hub P/N 204-102-101-31.

<sup>4</sup> Do not mix MIL-PRF-2104, A-A-52039, MIL-PRF-46167, MIL-PRF-23699, and for MIL-PRF-7808 oils, except during an emergency. If the oils are mixed, the system shall be flushed within six hours and filled with the proper oil. An entry on DA Form 2408-13 is required when the oils are mixed.

<sup>5</sup> For use in ambient temperatures above minus 35 C/30 F.

## CAUTION

Prolonged contact with hydraulic fluid or its mist can irritate eyes and skin. After any prolonged contact with skin, immediately wash contacted area with soap and water. If liquid is swallowed, do not induce vomiting, get immediate medical attention. When fluid is decomposed by heating, toxic gases are released.

<sup>6</sup> Refer to stencil on grip assembly to determine proper lubrication requirements.

<sup>7</sup> MIL-PRF-2104, A-A-52039, and MIL-PRF-46167 must be used in hub P/N 204-012-101-31 as follows.

Average Temp Range	Specification
+ 5 C and above.....	MIL-PRF-2104, Grade 40 NATO Code 0-230
-18 C to +5 C.....	MIL-PRF-2104, Grade 30 NATO Code, 0-230 or A-A-52039, Grade 30
-29 to -18 C.....	MIL-PRF-2104, Grade 10 NATO Code, 0-230 or A-A-52039, Grade 10W30
-54 to -20 C.....	MIL-PRF-46167, DEXRON II Automatic transmission fluid.

Approved domestic commercial fuels (spec. ASTM D-1655-70):  
Manufactures designation –

Jet B-JP4	Jet A-JP5 Type	Jet A-1-JPS Type
American JP-4	American Type A	
Aerojet B	Aerojet A Richfield A	Aerojet A-1 Richfield A-1
B.P.A.T.G.		B.P.A.T.K.
	CITGO A	
Conoco JP-4	Conoco Jet-50	Conoco Jet-60
Gulf Jet B	Gulf Jet A	Gulf Jet A-1
EXXON Turbo Fuel B	EXXON A	EXXON A-1
Mobil Jet B	Mobil Jet A	Mobile Jet A-1
Philjet JP-4	Philjet A-50	
Aeroshell JP	Aeroshell 640 Superjet A Jet A Kerosine	Aeroshell 650 Superjet A-1 Jet A-1 Kerosine
Chevron B	Chevron A-50	Chevron A-1
Texaco Avjet B	Avjet A	Avjet A-1
Union JP-4	76 Turbine Fuel	

Approved foreign commercial fuels:

Country	F-40	F-44
Belgium	BA-PF-2B	
Canada	3GP-22F	3-6P-24e
Denmark	JP4 MIL-DTL-5624	
France	Air 3407A	
Germany	VTL-9130-006	UTL 9130-007/UTL 9130-010
Greece	JP-4 MIL-DTL-5624	
Italy	AA-M-C-1421	AMC-143
Netherlands	JP-4 MIL-DTL-5624	D. Eng Rd 2493
Norway	JP-4 MIL-DTL-5624	
Portugal	JP-4 MIL-DTL-5624	
Turkey	JP-4 MIL-DTL-5624	
United Kingdom (Britain)	D. Eng. Rd 2454	E. Eng Rd 2498

FIGURE 14. Example of table of approved fuels, oils, and fluids (sheet 1 of 2)

## MIL-PRF-63029J

*NOTE* Anti-icing and Biocidal Additive for Commercial Turbine Engine Fuel – The fuel system icing inhibitor shall conform to ASTM D 4171. The additive provides anti-icing protection and also functions as a biocide to kill microbial growths in helicopter fuel systems. Icing inhibitors conforming to ASTM D 4171 shall be added to commercial fuel, not contaminating an icing inhibitor, during refueling operations, regardless of ambient temperatures. Refueling operations shall be accomplished in accordance with accepted commercial procedures.

Approved domestic commercial oils for MIL-PRF-7808: Manufacturers designation –

PQ Turbine Oil 8365  
 ESSO/ENCO Turbo Oil 2389  
 RM-184A/RM-201A

## CAUTION

Do not use Shell Oil Co., part No. 37, qualification No. 7D-1 oil (MIL-PRF-7808). It can be harmful to seals made of silicone.

---

Approved domestic oils for MIL-PRF-23699: Manufacturer designation:  
 PQ Turbine Lubricant 5247/6423/6700/7731/8878/9595  
 Brayco 899/899-G/899-S

Castrol 205  
 Jet Engine Oil 5  
 STO-21919/STO-21919A/STD-6530  
 HATCOL 3211/3611  
 Turbo Oil 2380 (WS-6000)/2395 (WS-6459)/2392/2393  
 Mobil Jet II RM-139A/Mobil Jet II RM-147A/Avrex S Turbo 260/Avrex S Turbo 265  
 Royco 899 (C-915)/899SC/Stauffer Jet II  
 Aeroshell Turbine Oil 500  
 Aeroshell Turbine Oil 550  
 Chevron Jet Engine Oil 5  
 Stauffer 6924/Jet II  
 SATO 7377/7730, TL-8090

---

**FIGURE 14. Example of table of approved fuels, oils, and fluids (sheet 2 of 2)**

## MIL-PRF-63029J

<b>Control/ Indicator</b>	<b>Function</b>
LO SET knob	Either pilot's LO SET knob applies power to the altimeter system. LO set indicated on the altimeters can be set independently. Both LO set indices must be masked to turn the set off.
HI SET knob	Sets position of HI set index and tests altimeter system when pressed.
LO set index	Indicates altitude trip point for LO caution light.
HI set index	Indicates altitude trip point for HI caution light.
Indicator pointer	Indicates absolute altitude from 0 to 1,500 feet.
Digital indicator	Provides direct reading four digit indication of absolute altitude from 0 to 1,500 feet.
LO caution light	Comes on when helicopter descends below altitude on LO set index.
HI caution light	Light comes on when helicopter rises above altitude on HI set index.

**FIGURE 15. Formatting example of control and indicator table or control display unit table.**

MIL-PRF-63029J

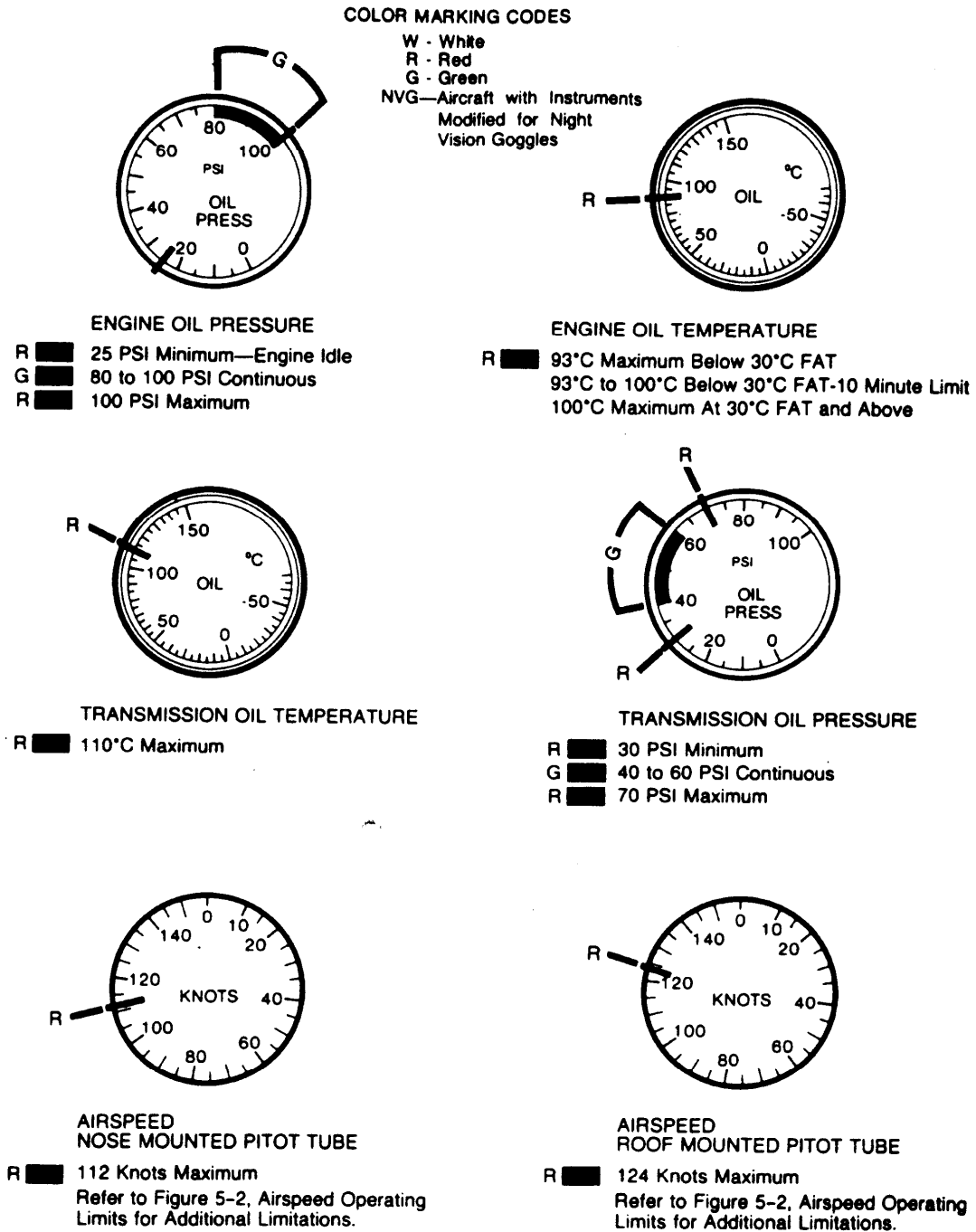
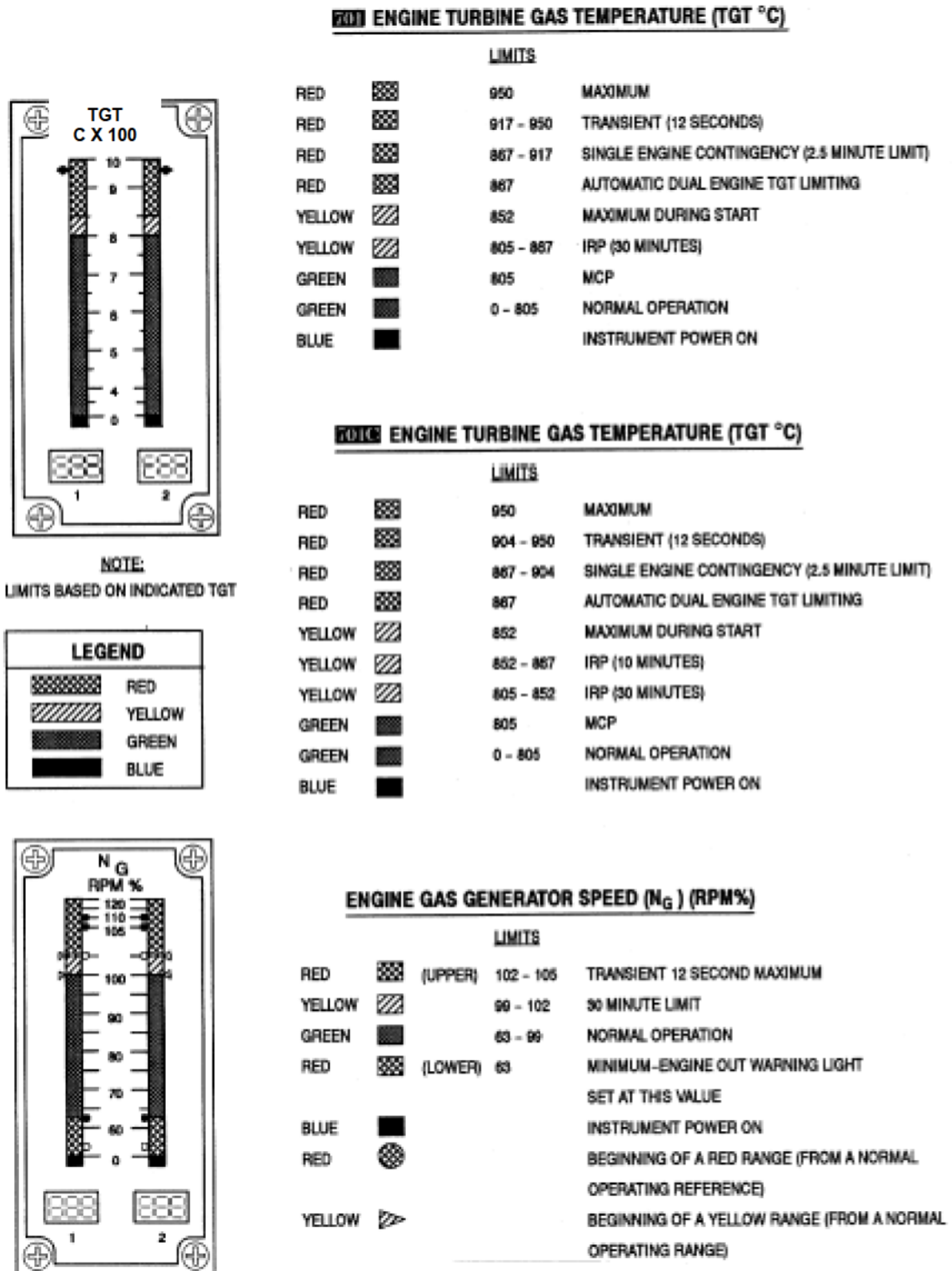

FIGURE 16. Example of instrument/display operating ranges and markings (sheet 1 of 2)

MIL-PRF-63029J



**NOTE:**  
LIMITS BASED ON INDICATED TGT

LEGEND	
	RED
	YELLOW
	GREEN
	BLUE

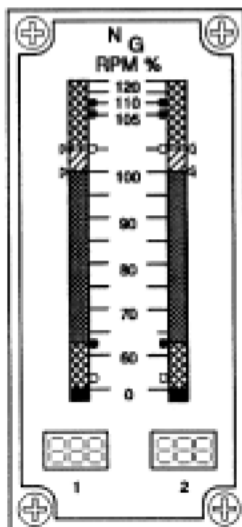

FIGURE 16. Example of instrument/display operating ranges and markings (sheet 2 of 2)

MIL-PRF-63029J

### AIRSPEED OPERATING LIMITS

**EXAMPLE**

**WANTED**  
INDICATED AIRSPEED  
AND DENSITY ALTITUDE

**KNOWN**  
GROSS WEIGHT = 8500 LB  
PRESSURE ALTITUDE = 7500 FEET  
FAT = -20°C  
ROOF MOUNTED SYSTEM

**METHOD**  
ENTER PRESSURE ALTITUDE  
MOVE RIGHT TO FAT  
MOVE DOWN TO GROSS WEIGHT  
MOVE LEFT, READ INDICATED  
AIRSPEED = 110 KNOTS  
REENTER PRESSURE ALTITUDE  
MOVE DOWN, READ DENSITY  
ALTITUDE = 5000 FEET

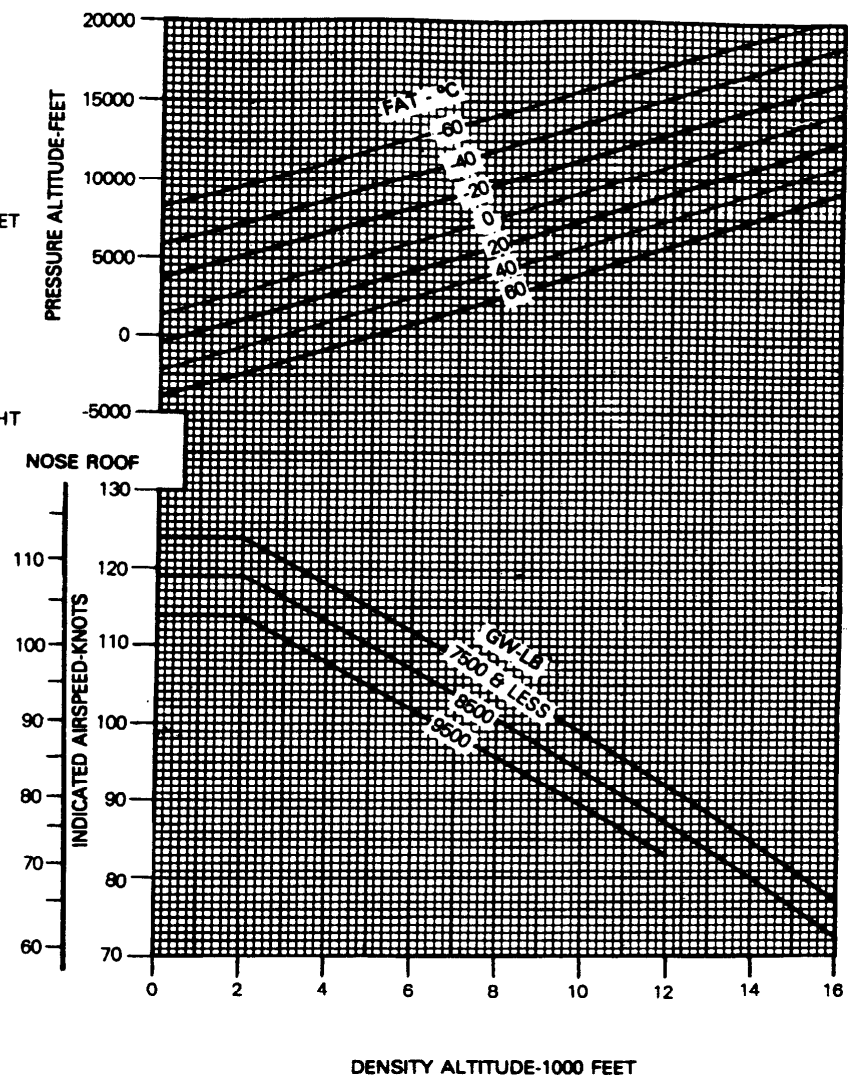

DATA BASIS: DERIVED FROM FLIGHT TEST

FIGURE 17. Airspeed operating limits chart

MIL-PRF-63029J

## FLIGHT ENVELOPE

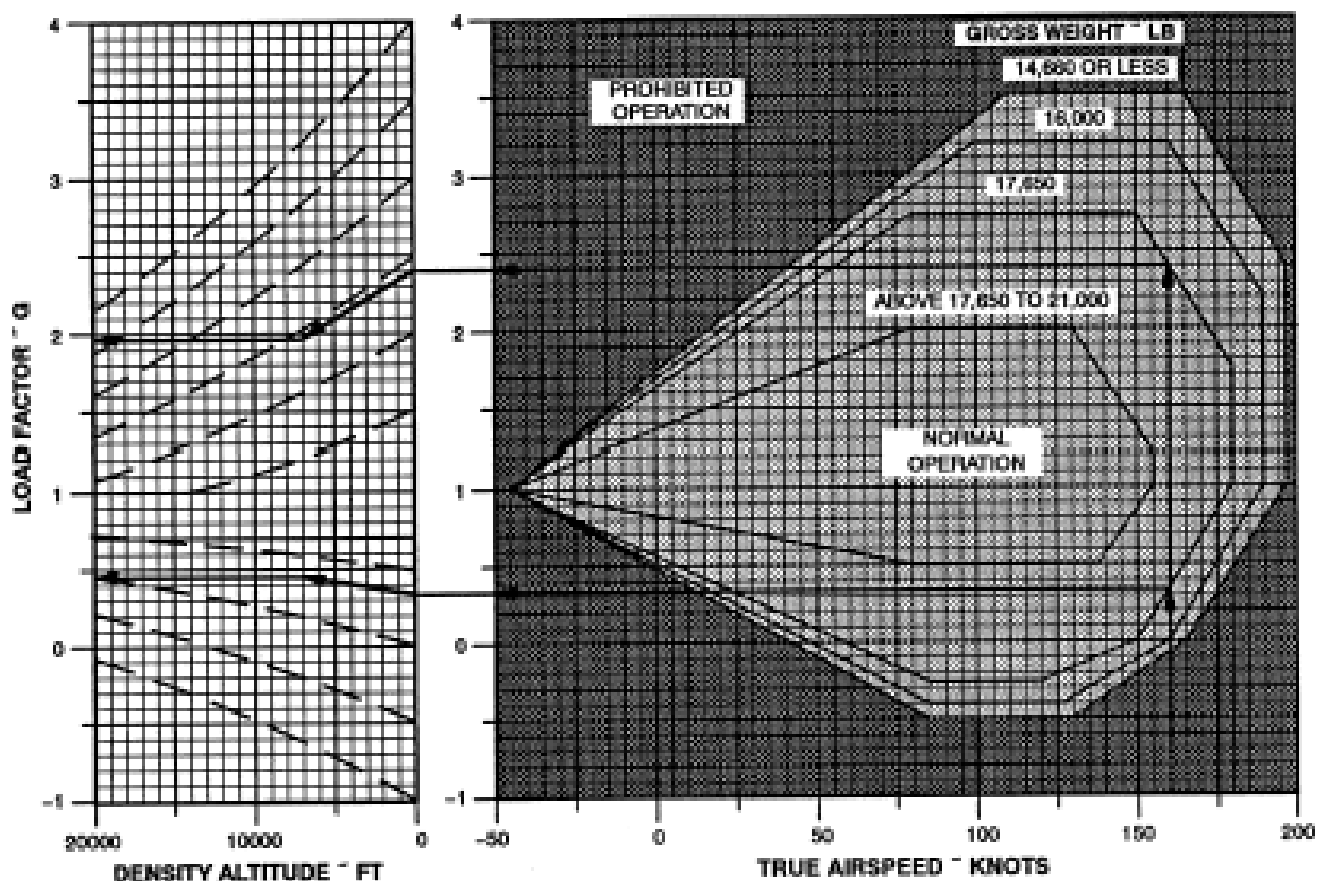
**EXAMPLE****WANTED**

MAXIMUM AND MINIMUM LOAD FACTOR

**KNOWN**

GROSS WEIGHT = 17,650 POUNDS

DENSITY ALTITUDE = 7000 FEET

AIRSPEED = 160 KTAS

**METHOD**ENTER AT  $V = 160$  KT. MOVE UP TO UPPER AND LOWER ENVELOPE BOUNDARIES FOR

GROSS WEIGHT = 17,650 POUNDS

MOVE LEFT TO DENSITY ALTITUDE OF ZERO FEET

SLIDE TO LEFT ALONG DASHED LINES TO 7000 FEET DENSITY ALTITUDE

MOVE LEFT TO LOAD FACTOR SCALE, READ MAX  $G = 1.96$ , MIN  $G = 0.46$ **FIGURE 18. Flight envelope chart**



MIL-PRF-63029J

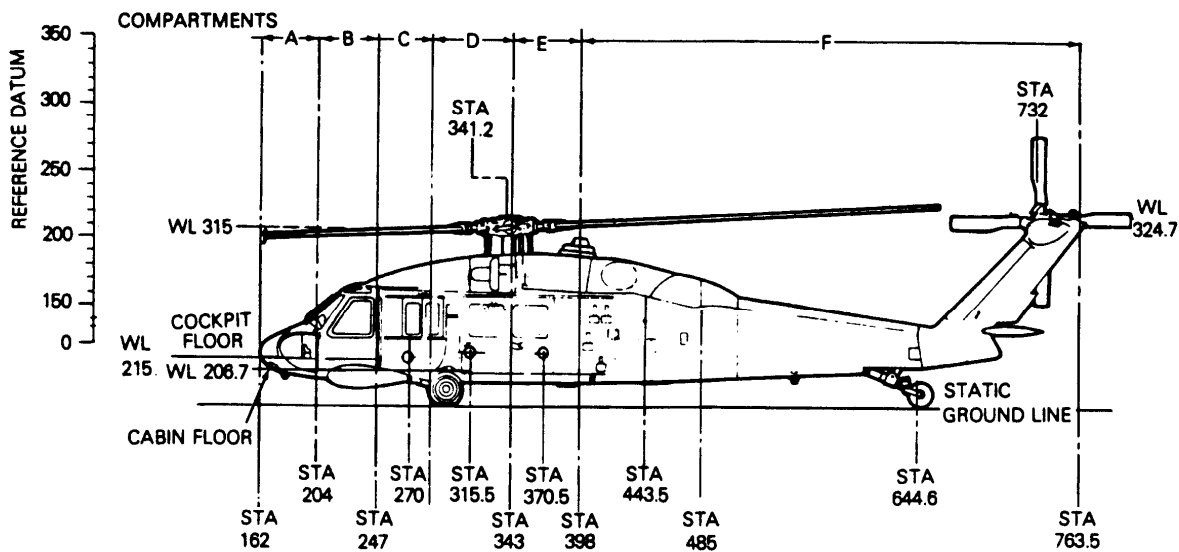
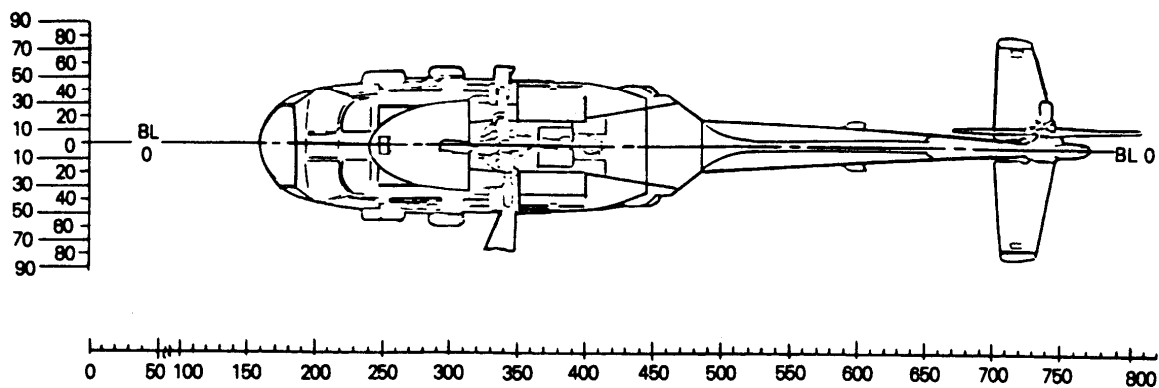

FIGURE 19. Aircraft compartments and stations (sheet 1 of 2)

MIL-PRF-63029J

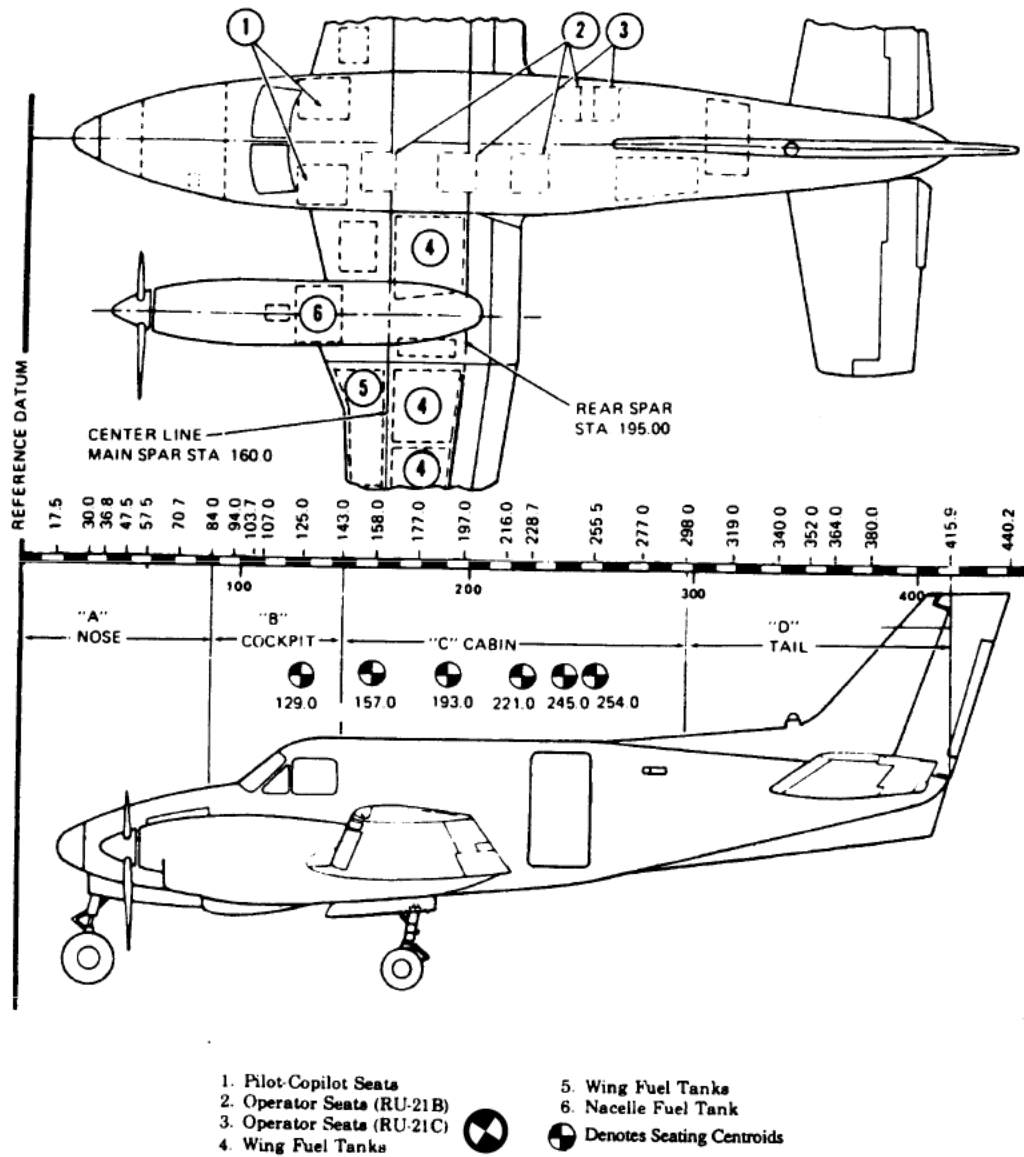

FIGURE 19. Aircraft compartments and stations (sheet 2 of 2)

MIL-PRF-63029J

**EXAMPLE**

**WANTED**  
**FUEL MOMENT**

**KNOWN**  
**FUEL QUANTITY**  
**MAIN 1700 POUNDS**

**METHOD**

**FUEL MOMENTS**

ITEM	STA	WEIGHT LBS	MOM/1000
230-GALLON TANK (IB OR OB)	321	150	48
450-GALLON TANK (IB)	316	234	74

FOR MAIN TANK ENTER  
 AT 1700 POUNDS AND  
 MOVE RIGHT TO MAIN LINE.  
 MOVE DOWN READ  
 MOMENT / 1000 = 710

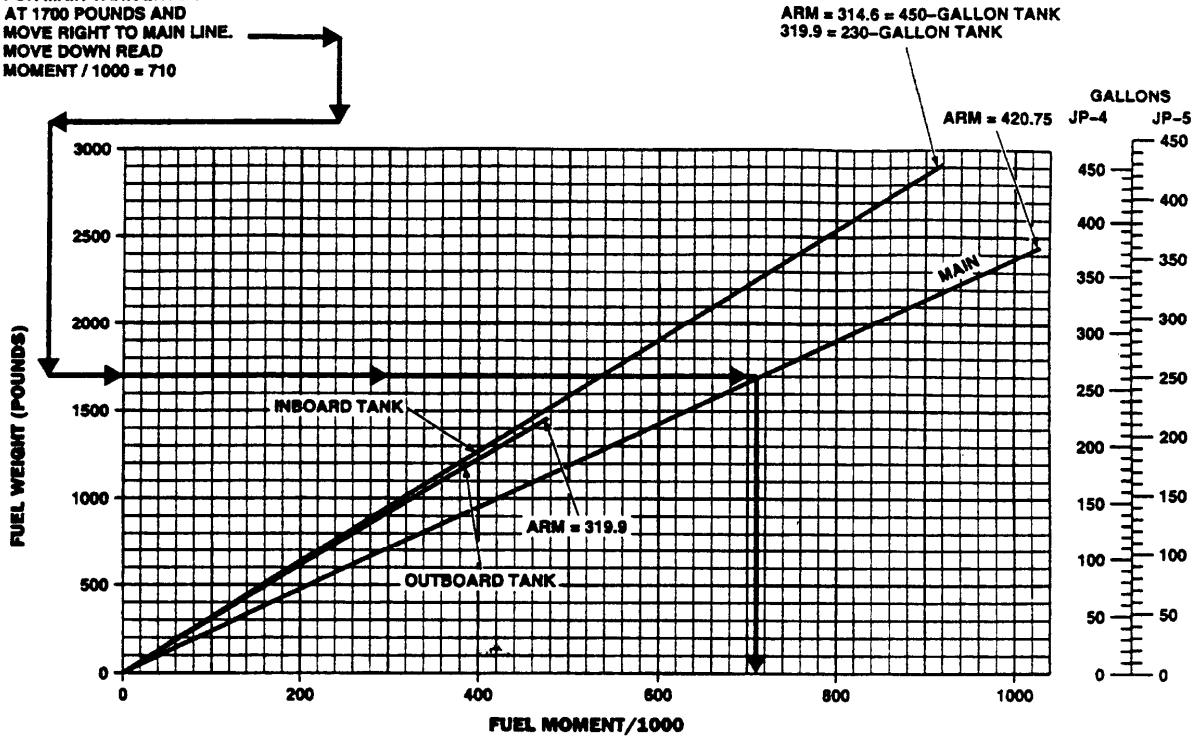
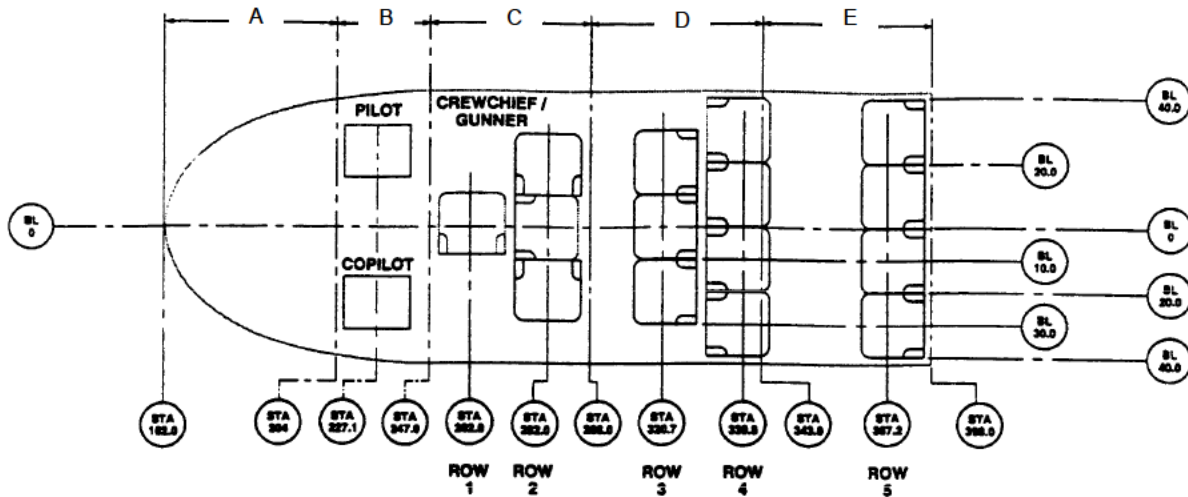

FIGURE 20. Fuel moment chart

MIL-PRF-63029J

**PERSONNEL MOMENTS**



**SEAT WEIGHT - AND MOMENT TABLE\***

ITEM	ROW	WEIGHT	MOM / 1000
CREWCHEIF / GUNNER (2)	2	43	12
TROOPS (3)	3	48	15
TROOPS (3)	4	48	16
TROOPS (4)	5	63	25
<b>TOTAL-12 SEATS</b>		<b>202</b>	<b>68</b>
<b>ALTERNATE SEATING (BROKEN LINES)</b>			
FORWARD TROOP SEAT (1)	1	16	4
REAR FACING TROOP SEAT (1)	2	16	5
REAR FACING TROOP SEAT (1)	4	16	6
<b>TOTAL-15 SEATS</b>		<b>250</b>	<b>83</b>

\*SEAT WEIGHT AND MOMENTS SHOULD BE INCLUDED ON CHART C

**EXAMPLE**

**WANTED:**  
PERSONNEL MOMENTS

**KNOWN:**  
2 PERSONNEL IN ROW 3  
TOTAL WEIGHT 480 POUNDS

**METHOD:**  
ENTER WEIGHT AT 480 POUNDS—MOVE RIGHT TO ROW 3.—MOVE DOWN. READ MOMENT / 1000=154



**FIGURE 21. Personnel moments chart (sheet 1 of 3)**

MIL-PRF-63029J

**PERSONNEL MOMENTS**

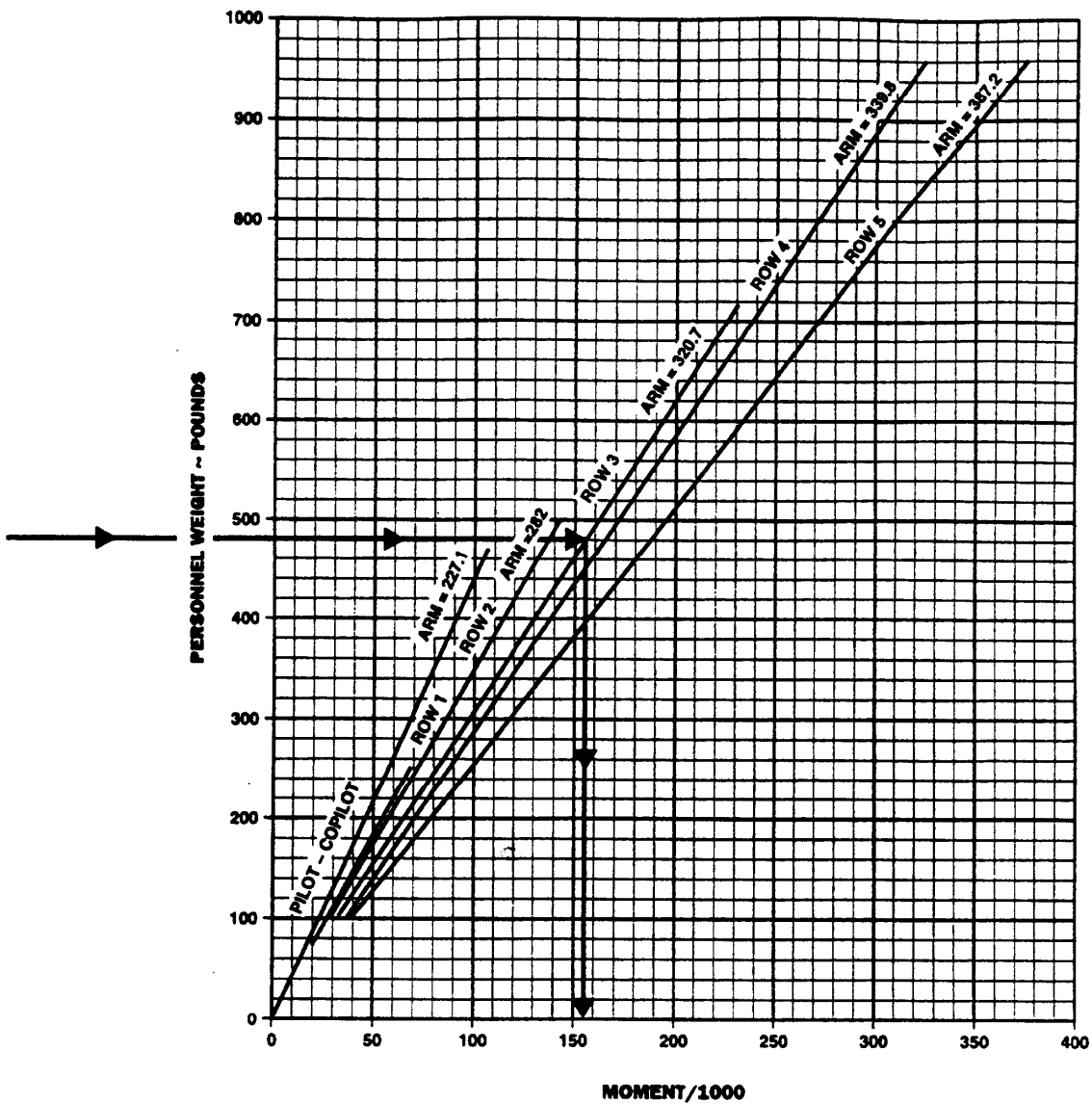

**DATA BASIS: CALCULATED**

**FIGURE 21. Personnel moments chart (sheet 2 of 3)**

MIL-PRF-63029J

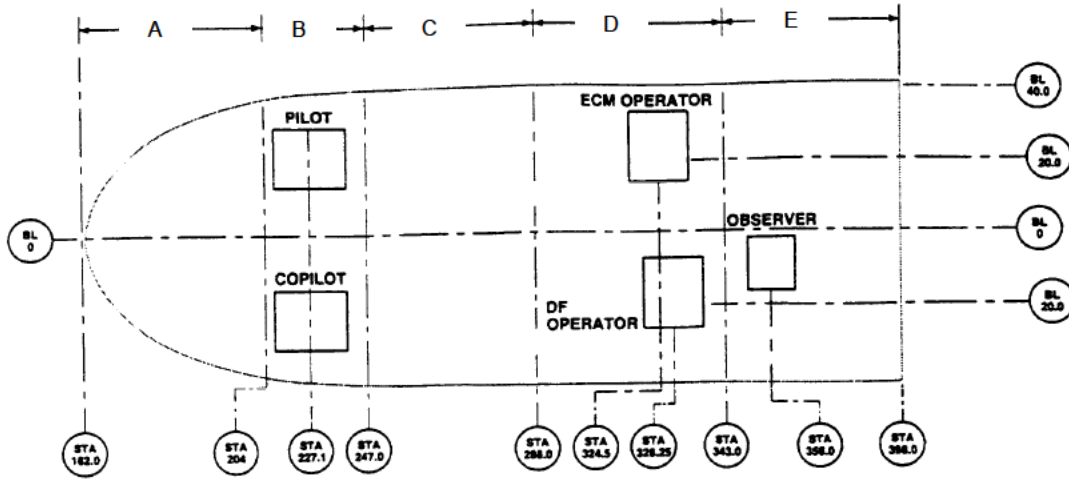

* ITEM	STA	WEIGHT	MOM / 1000
OBSERVER SEAT	356.0	18	6
TOTAL - 1 SEAT	-	18	6

\* SEAT WEIGHT AND MOMENTS SHOULD BE INCLUDED ON CHART C.

**EXAMPLE**  
**WANTED**  
 PERSONNEL MOMENTS  
  
**KNOWN**  
 PERSONNEL AT STA 356  
 OBSERVER - 210 POUNDS  
  
**METHOD**  
 ENTER WEIGHT AT 210  
 POUNDS - MOVE RIGHT  
 TO OBSERVER ARC (STA 356.0)  
 MOVE DOWN READ  
 MOMENT / 1000 = 75

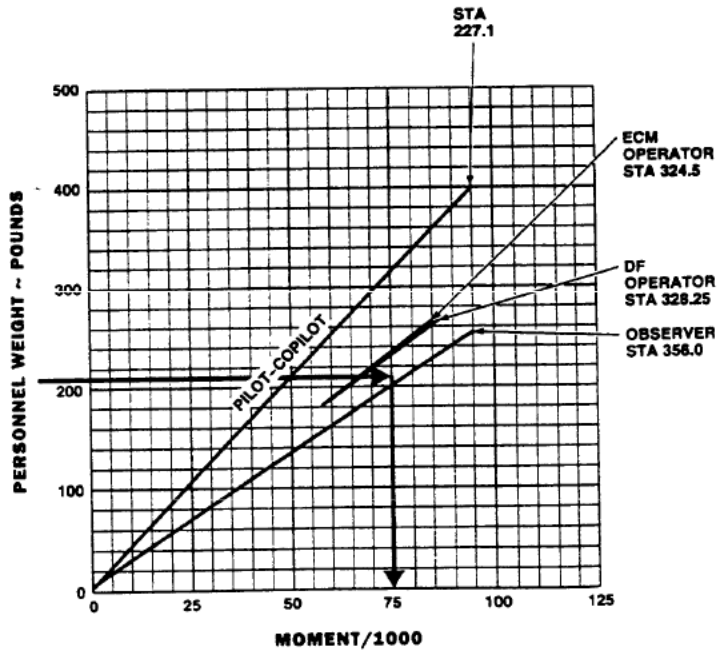

DATA BASIS: CALCULATED

FIGURE 21. Personnel moments chart (sheet 3 of 3)

## MIL-PRF-63029J

Item	Qty	Inboard Station 2, 3 or Outboard Station 1, 4		Item	Qty	Inboard Station 2, 3 or Outboard Station 1, 4	
		Accum Weight (lb)	Moment (in.-lb/100)			Accum Weight (lb)	Moment (in.-lb/100)
Missile	1	98.5	188	H519 Rocket	1	20.6	41
Missile	2	197.0	376	Rocket	2	41.2	81
Missile	3	295.5	564	Rocket	3	61.8	122
Missile	4	394.0	751	Rocket	4	82.4	162
				Rocket	5	103.0	203
				Rocket	6	123.6	243
				Rocket	7	144.2	284
				Rocket	8	164.8	324
				Rocket	9	185.4	365
				Rocket	10	206.0	406
				Rocket	11	226.6	446
				Rocket	12	247.2	487
				Rocket	13	267.8	527
				Rocket	14	288.4	568
				Rocket	15	309.0	608
				Rocket	16	329.6	649
				Rocket	17	350.2	690
				Rocket	18	370.8	730
				Rocket	19	391.4	771

FIGURE 22. Armament loading data chart

MIL-PRF-63029J

**EXAMPLE**

**WANTED**

CARGO MOMENT FOR A GIVEN CARGO WEIGHT AND FUSELAGE STATION

**KNOWN**

CARGO WEIGHT 1000 LBS  
LOCATION FS105

**METHOD**

ENTER INTERNAL CARGO WEIGHT  
MOVE RIGHT TO FS105  
MOVE DOWN TO BASE-LINE AND  
READ 1050 INCH POUNDS/100

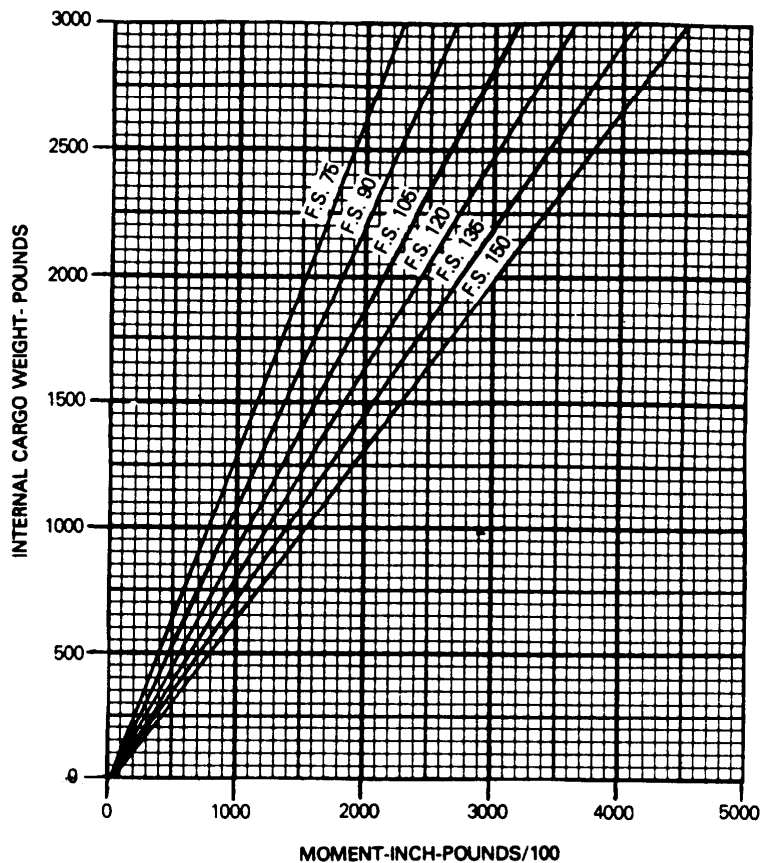

**FIGURE 23. Cargo moments chart**



MIL-PRF-63029J

**EXAMPLE**

**WANTED**

DETERMINE CENTER OF GRAVITY FOR KNOWN WEIGHT AND MOMENT

**KNOWN**

GROSS WEIGHT EQUALS 8460 POUNDS, MOMENT/100 EQUALS 11,900 INCH-POUNDS

**METHOD**

MOVE RIGHT FROM 8460 POUNDS TO A POINT APPROXIMATELY 1/2 OF THE DISTANCE BETWEEN 11,800 AND 12,000 INCH-POUND DIAGONAL LINES. FROM THIS POINT PROJECT DOWN TO READ 140.6 ON THE CENTER OF GRAVITY SCALE (FUSELAGE STATION IN INCHES).

**NOTE**

WHEN CG IS WITHIN SHADED AREA AFT OF STATION 140.0, APPROACHES SHOULD BE TERMINATED TO A 5-FOOT HOVER FOR ADEQUATE TAIL ROTOR CLEARANCE.

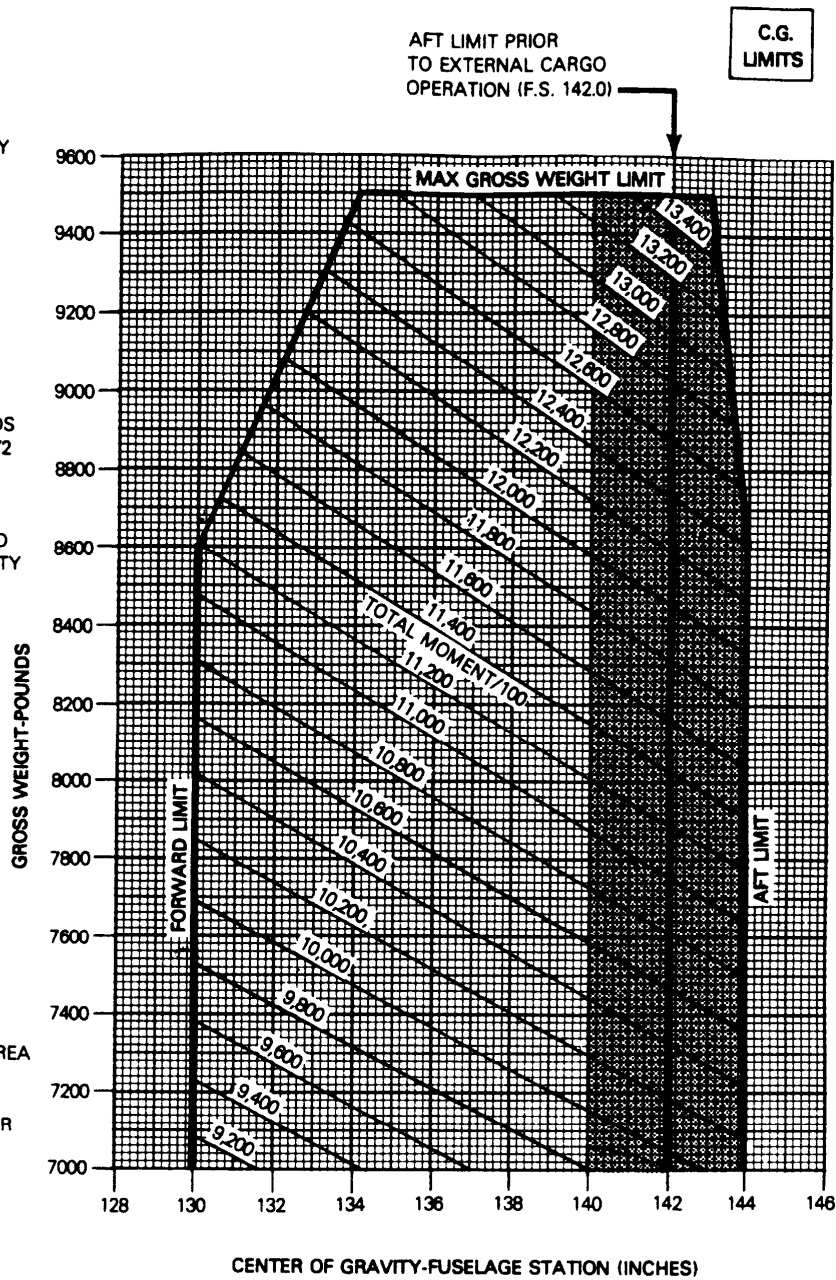

FIGURE 24. Center-of-gravity limits (sheet 1 of 2)

MIL-PRF-63029J

# CENTER OF GRAVITY LIMITS

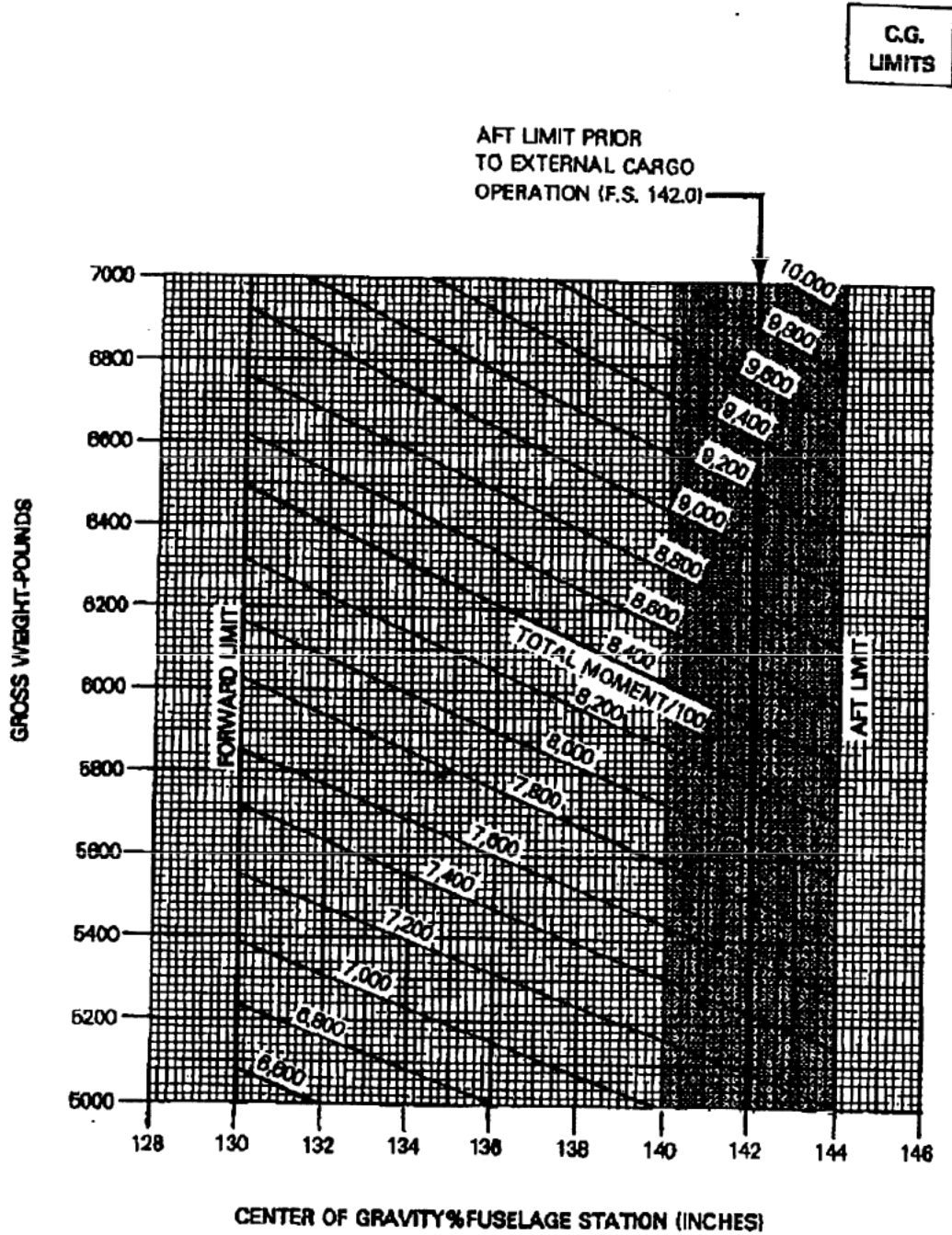

FIGURE 24. Center-of-gravity limits (sheet 2 of 2)

MIL-PRF-63029J

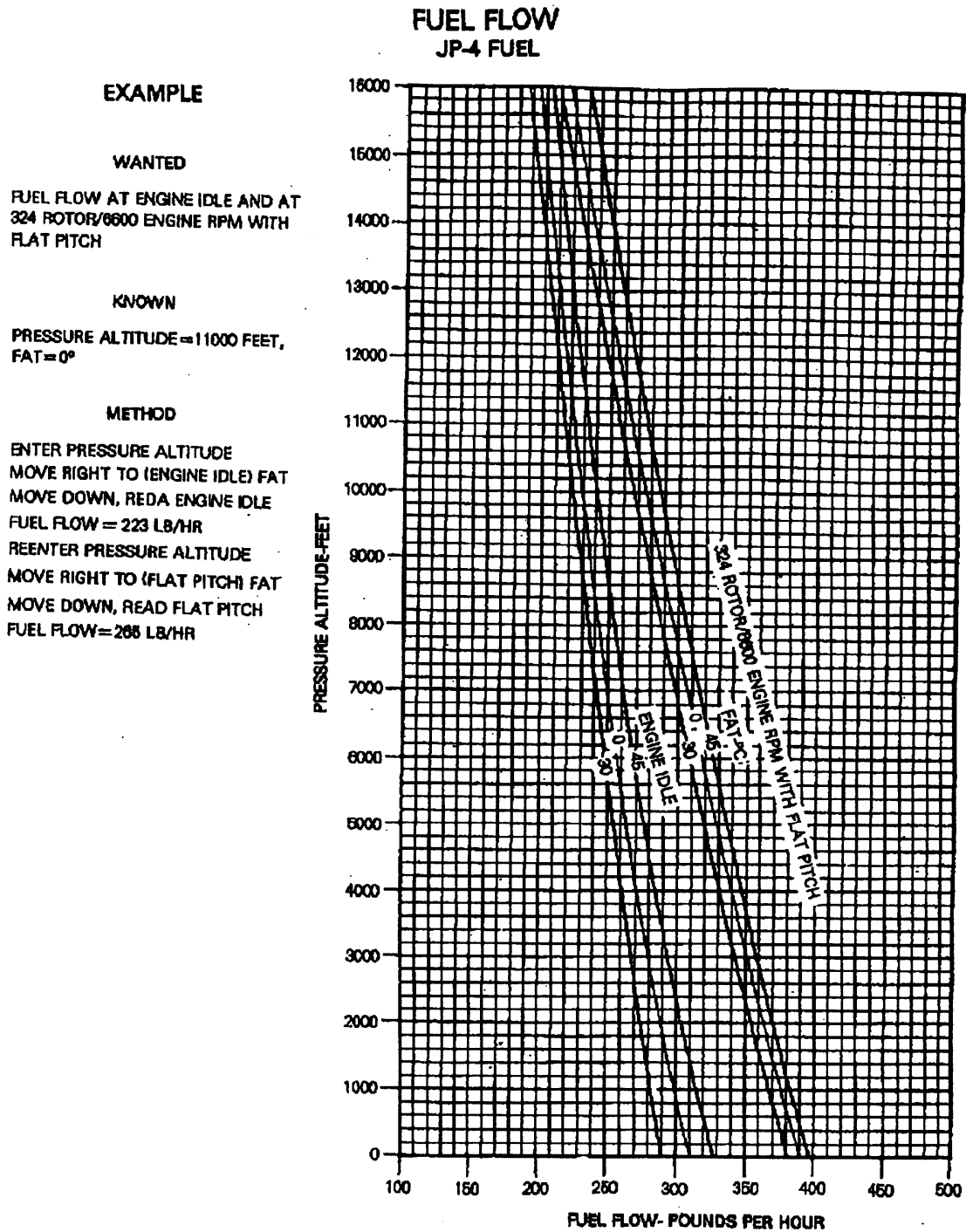

FIGURE 25. Fuel flow chart

MIL-PRF-63029J

**MAXIMUM TORQUE AVAILABLE**  
**30-MIN LIMIT 100% N, ANTI-ICE OFF**  
**ZERO AIRSPEED**

**MAXIMUM TORQUE AVAILABLE/IRP**  
**AH-64A**  
**T700-GE-701**

**EXAMPLE**

**WANTED**

SPECIFICATION TORQUE AVAILABLE  
 30-MIN. LIMIT.

**KNOWN**

FAT = +20 °C.

PRESSURE ALTITUDE = 4000 FT.

**METHOD**

ENTER AT KNOWN FAT = +20 °C.  
 MOVE RIGHT TO PRESSURE ALTITUDE  
 = 4000 FT. THEN MOVE DOWN  
 TO READ 97.5% TORQUE AVAILABLE  
 PER ENGINE. THIS DOES NOT EXCEED  
 2-ENGINE RED LINE. FOR DUAL  
 ENGINE OPERATION, TORQUE IS LIMITED  
 TO 100% PER ENGINE.

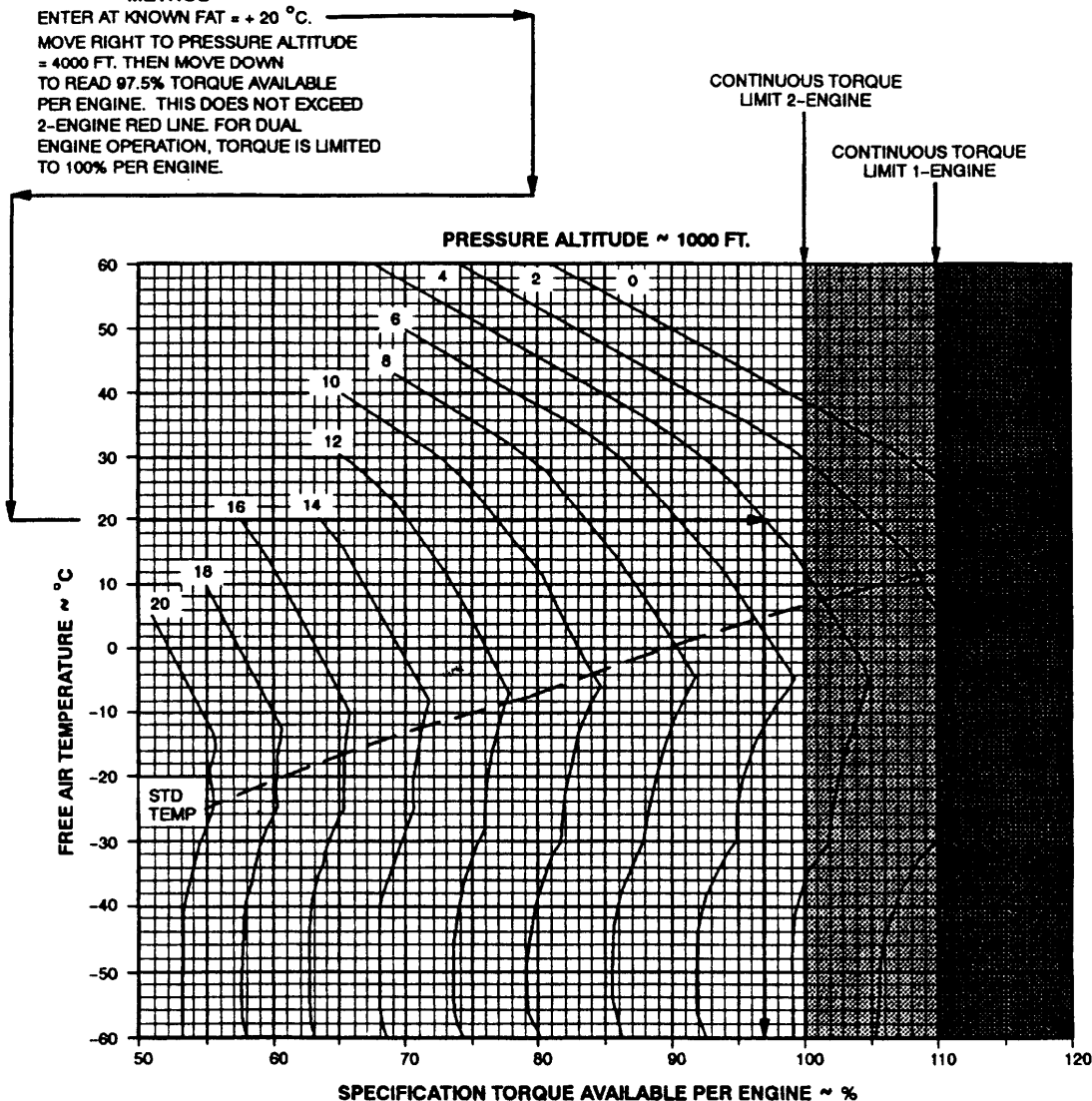

FIGURE 26. Maximum torque available (insert time) (RW)

MIL-PRF-63029J

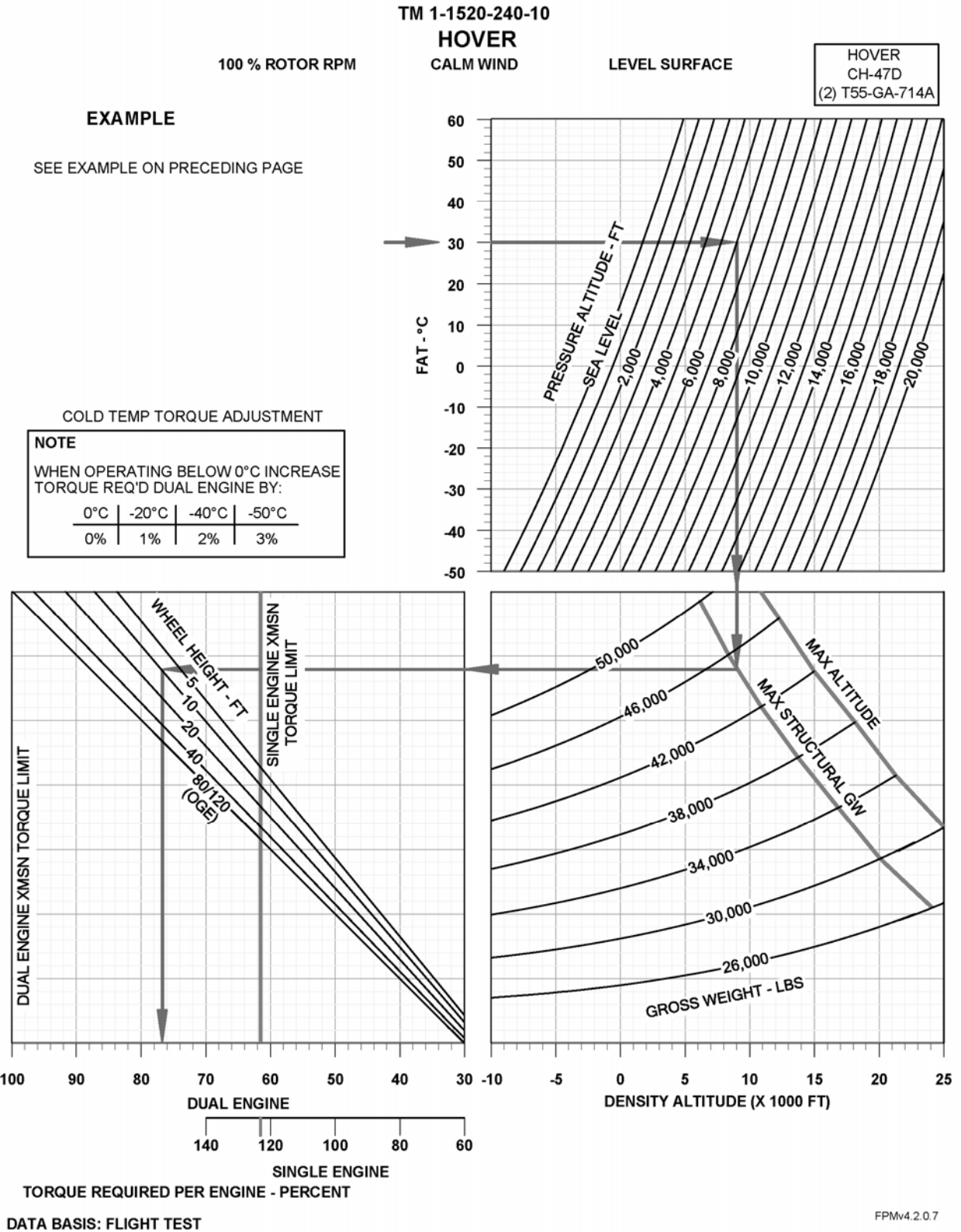

FIGURE 27. Hover chart

MIL-PRF-63029J

### TAKEOFF

LEVEL ACCELERATION, 3 FT SKID HEIGHT  
 324 ROTOR/6000 ENGINE RPM MAXIMUM TORQUE AVAILABLE  
 CALM WIND LEVEL SURFACE ALL CONFIGURATIONS

CLIMBOUT AT 32 KIAS ROOF, 30 KIAS NOSE

#### EXAMPLE I

**WANTED**

DISTANCE TO CLEAR OBSTACLE

**KNOWN**

MAXIMUM HOVER HEIGHT = 10 FEET  
 OBSTACLE HEIGHT = 50 FEET

**METHOD**

ENTER MAX HOVER HEIGHT  
 MOVE RIGHT TO OBSTACLE HEIGHT  
 MOVE DOWN, READ DISTANCE  
 TO CLEAR OBSTACLE = 700 FEET

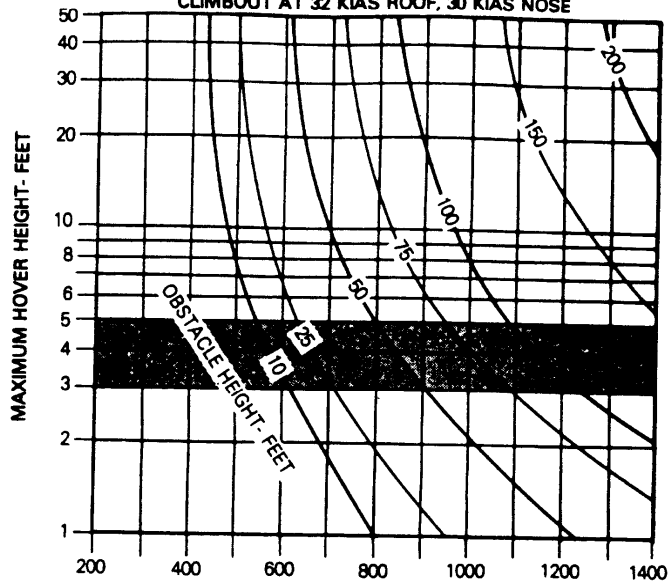

#### EXAMPLE II

**WANTED**

DISTANCE TO CLEAR OBSTACLE

**KNOWN**

MAX HOVER HEIGHT = 8 FEET  
 OBSTACLE HEIGHT = 50 FEET  
 CLIMBOUT AIRSPEED = 40 KNOTS

**METHOD**

ENTER MAX HOVER HEIGHT  
 MOVE RIGHT TO CLIMBOUT TRUE AIRSPEED  
 MOVE DOWN TO OBSTACLE HEIGHT  
 MOVE LEFT READ DISTANCE  
 TO CLEAR OBSTACLE = 630 FEET

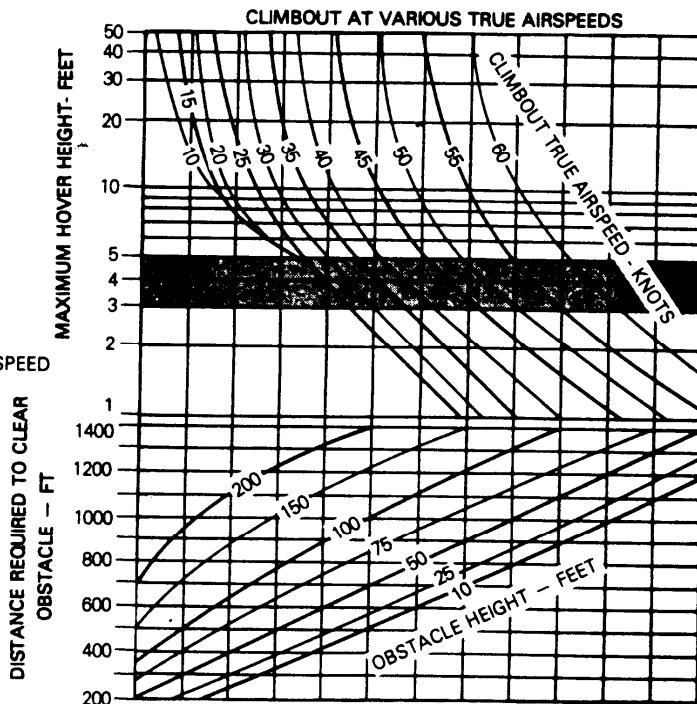

FIGURE 28. Takeoff chart

MIL-PRF-63029J

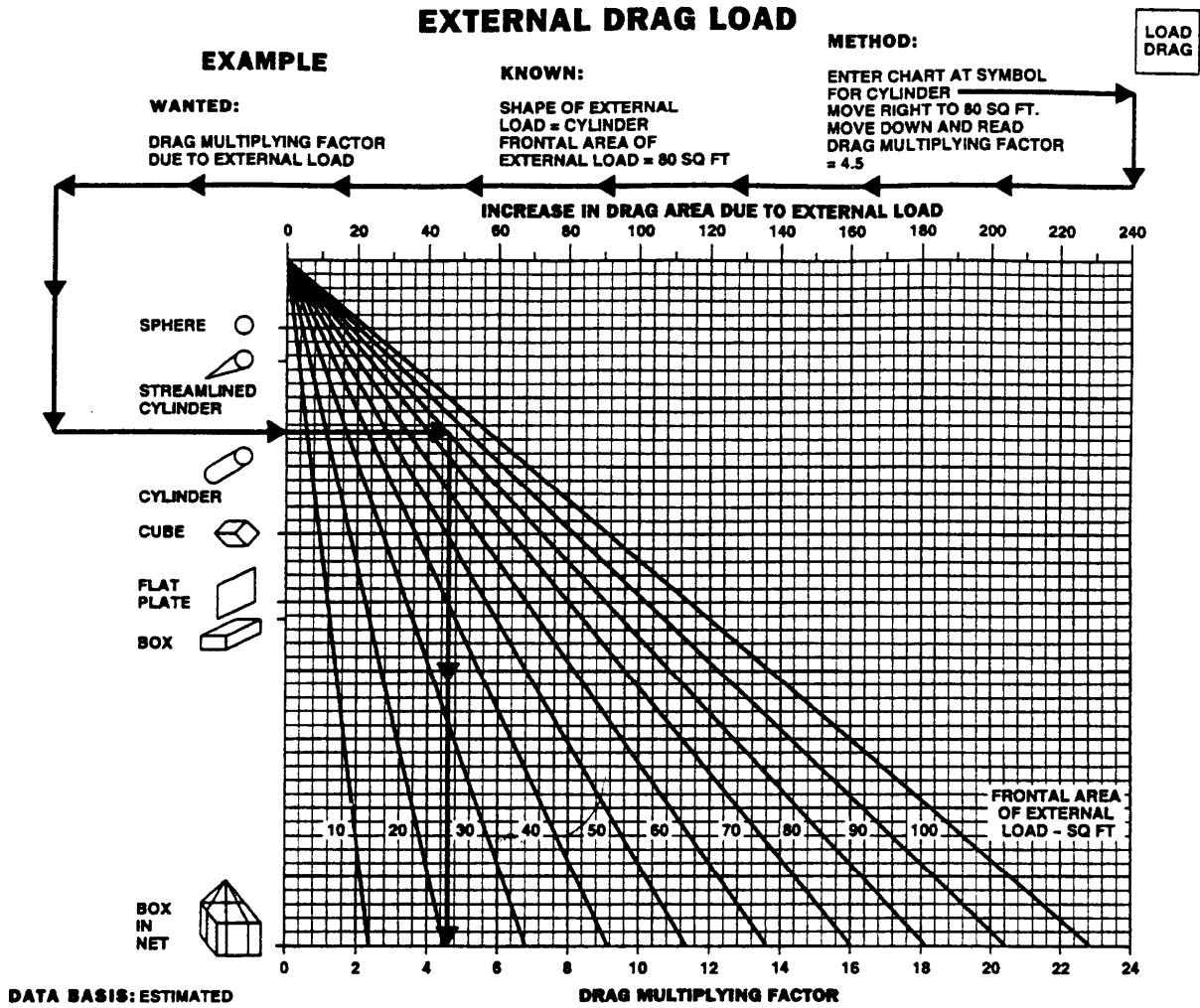

FIGURE 29. Drag chart (Sheet 1 of 3)

MIL-PRF-63029J

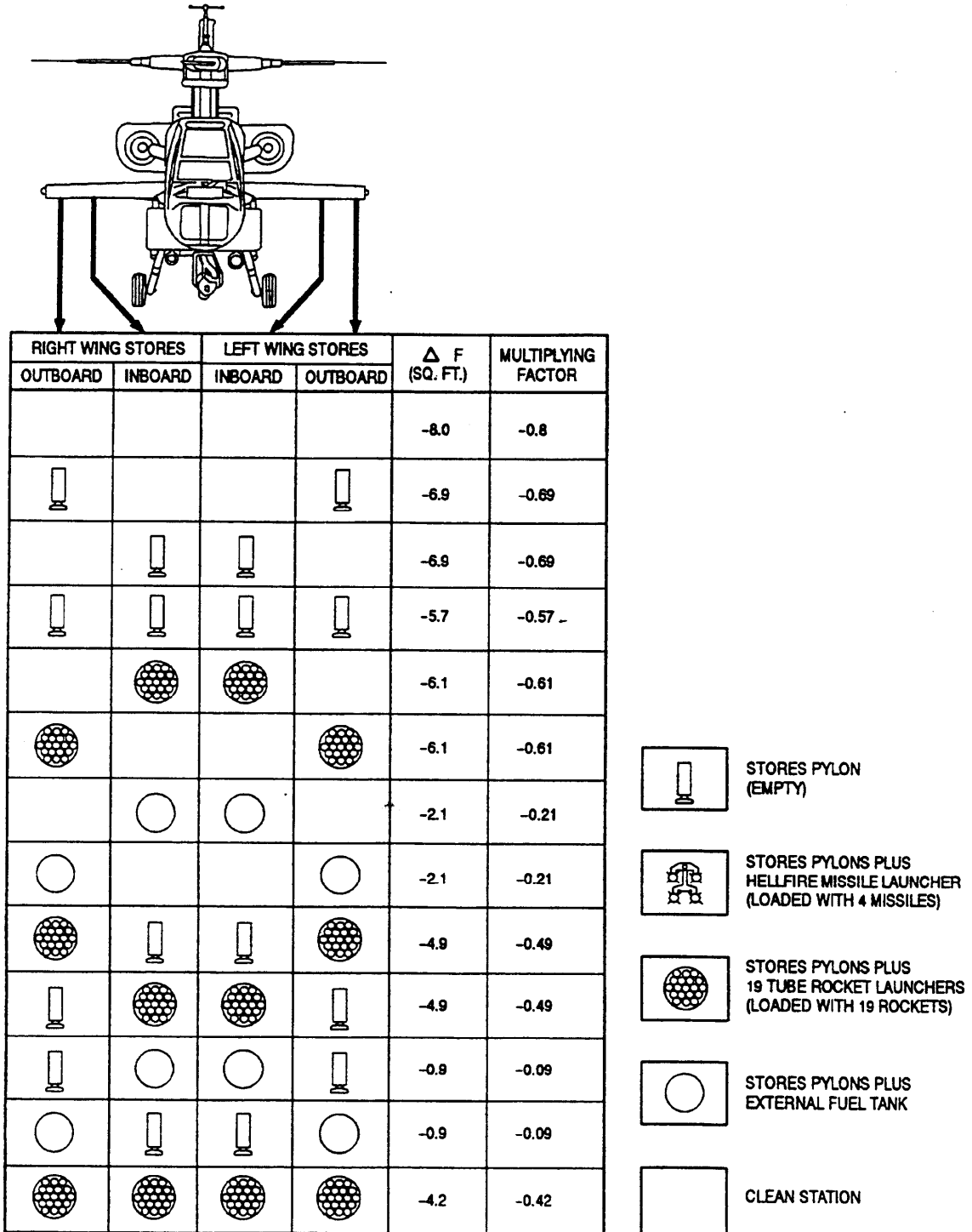

FIGURE 29. Drag chart (sheet 2 of 3)



MIL-PRF-63029J

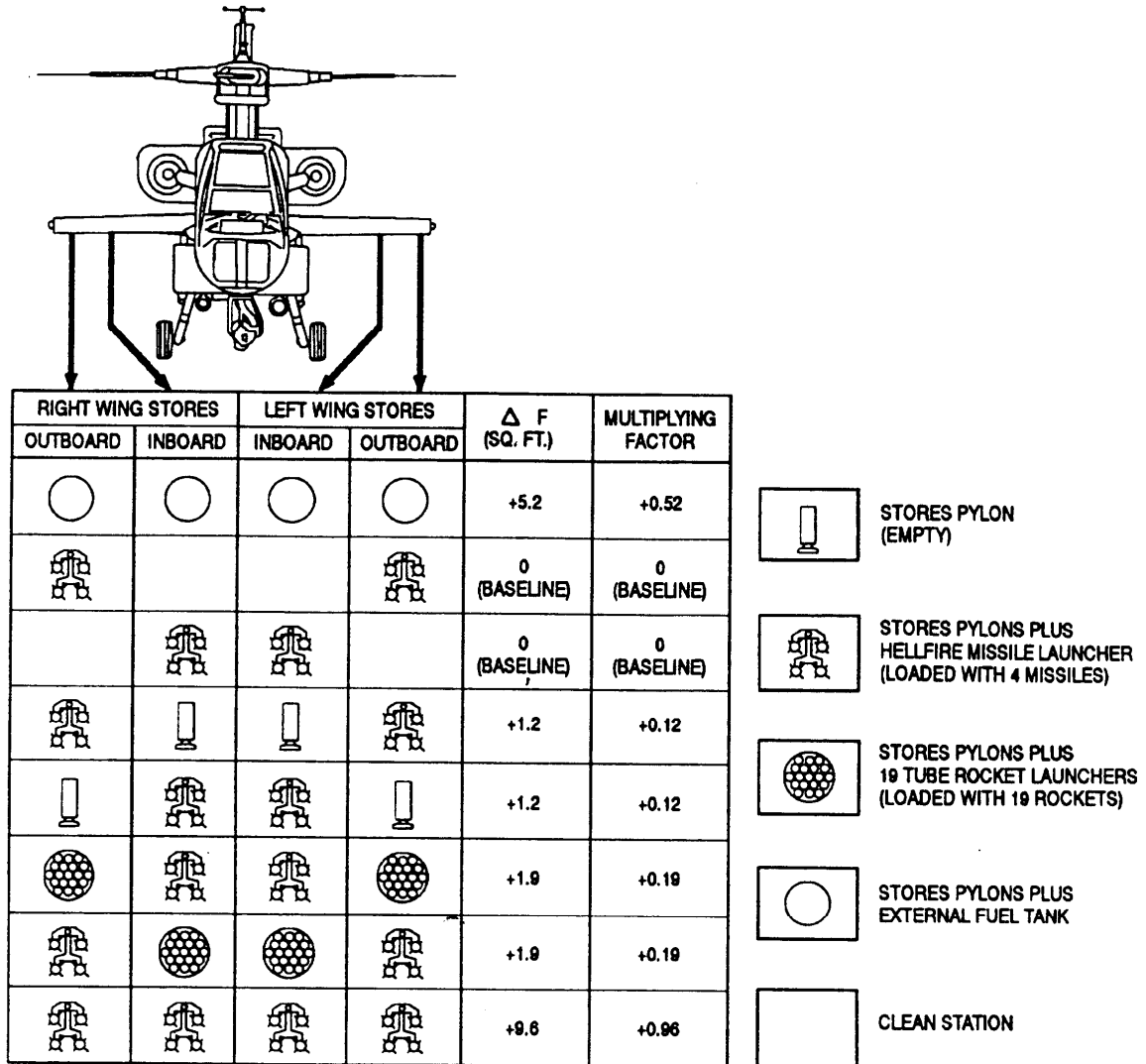

FIGURE 29. Drag chart (sheet 3 of 3)

MIL-PRF-63029J

TM 1-1520-240-10  
**CRUISE**

PRESSURE ALTITUDE - 6,000 FT  
CLEAN CONFIGURATION

CRUISE  
CH-47D  
(2) T55-GA-714A

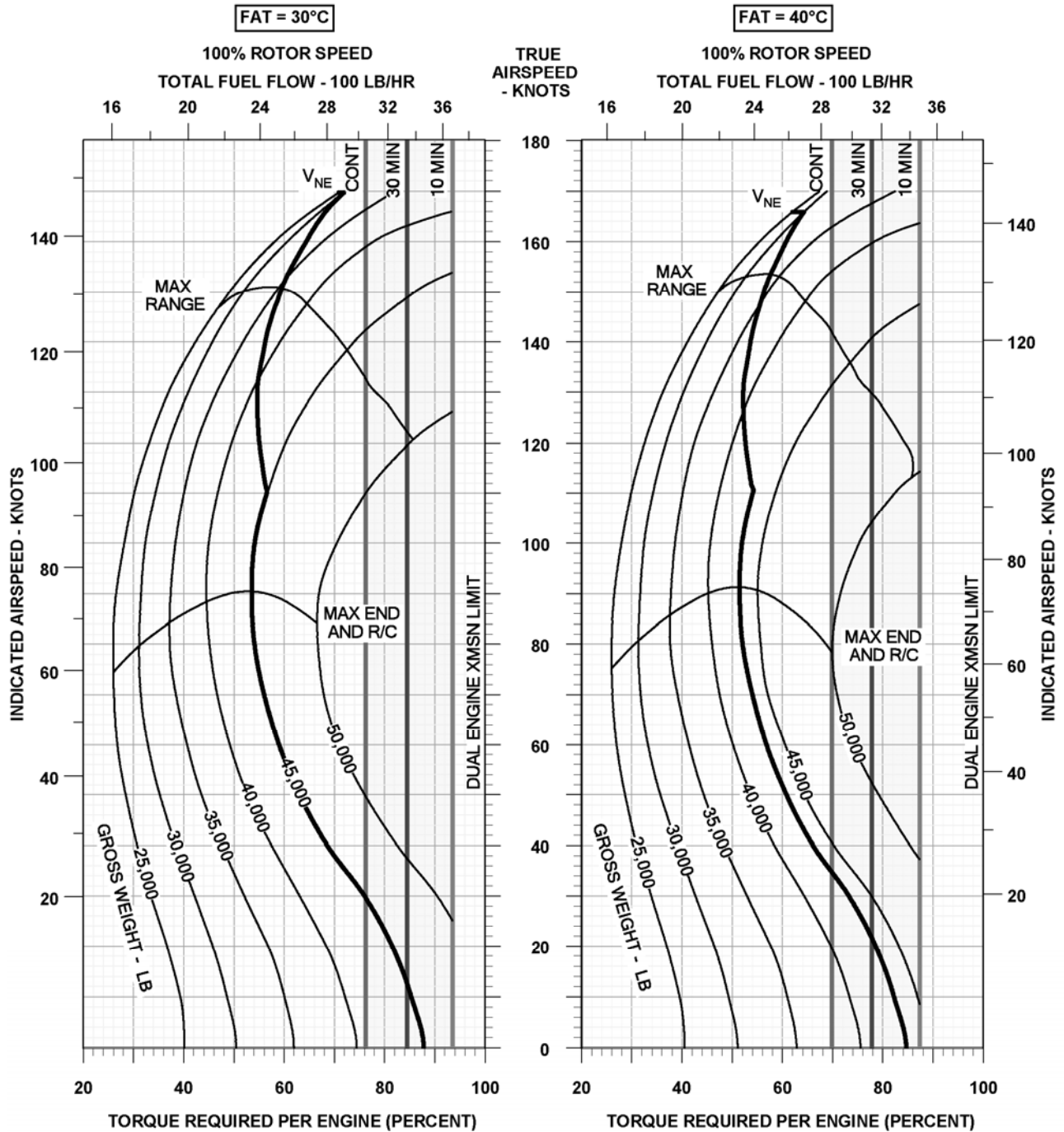

DATA BASIS: FLIGHT TEST

FPMv4.2.0.7

FIGURE 30. Cruise chart (RW)

MIL-PRF-63029J

**CLIMB-DESCENT**

314 ROTOR/8400 ENGINE RPM

**EXAMPLE**

**WANTED**

CALIBRATED TORQUE CHANGE  
FOR DESIRED R/C OR R/D

**KNOWN**

GROSS WEIGHT = 6000 LB  
DESIRED R/C = 1200 FT/MIN

**METHOD**

ENTER R/C  
MOVE RIGHT TO GROSS WEIGHT  
MOVE DOWN, READ CALIBRATED  
TORQUE CHANGE = 12.5 PSI

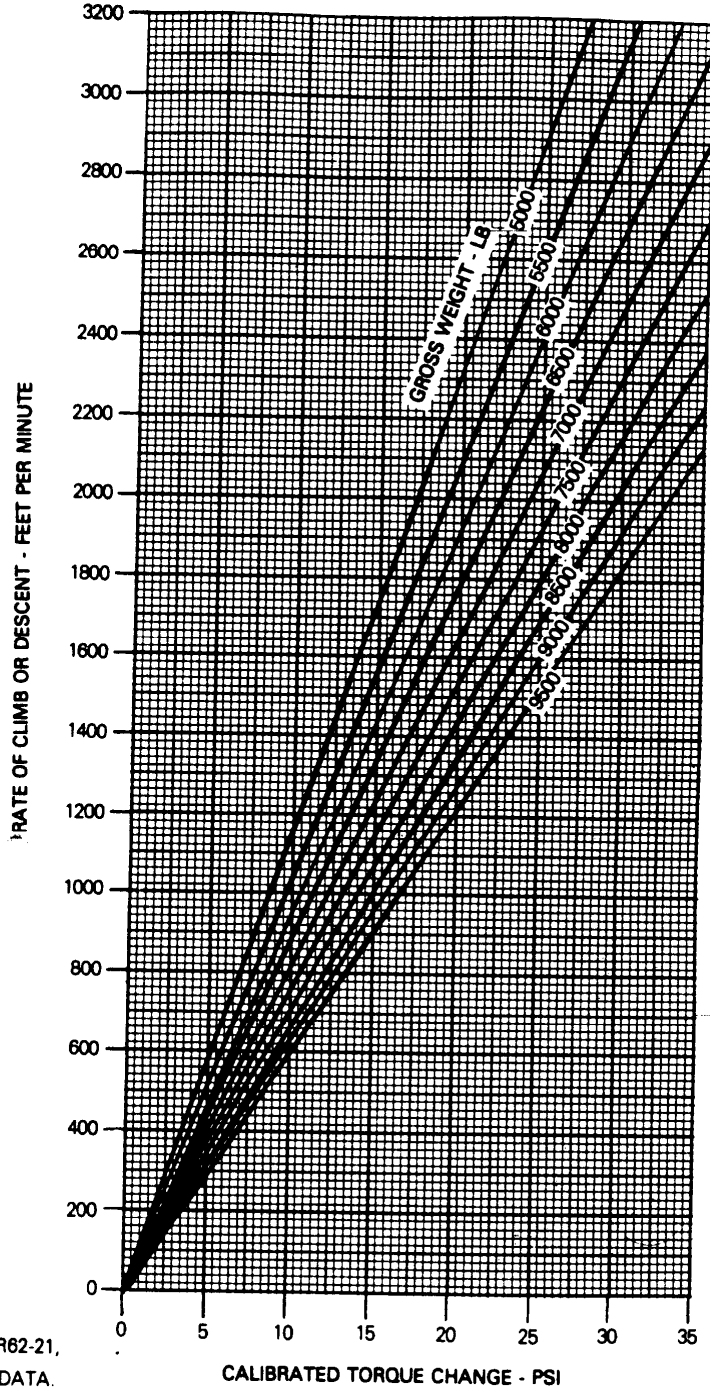

DATA BASIS: DERIVED FROM FLIGHT TEST FTC-TDR62-21,  
DECEMBER 1962, AND CALCULATED DATA.

**FIGURE 31. Climb-descent chart**

MIL-PRF-63029J

## AIRSPEED CALIBRATION - NORMAL SYSTEM

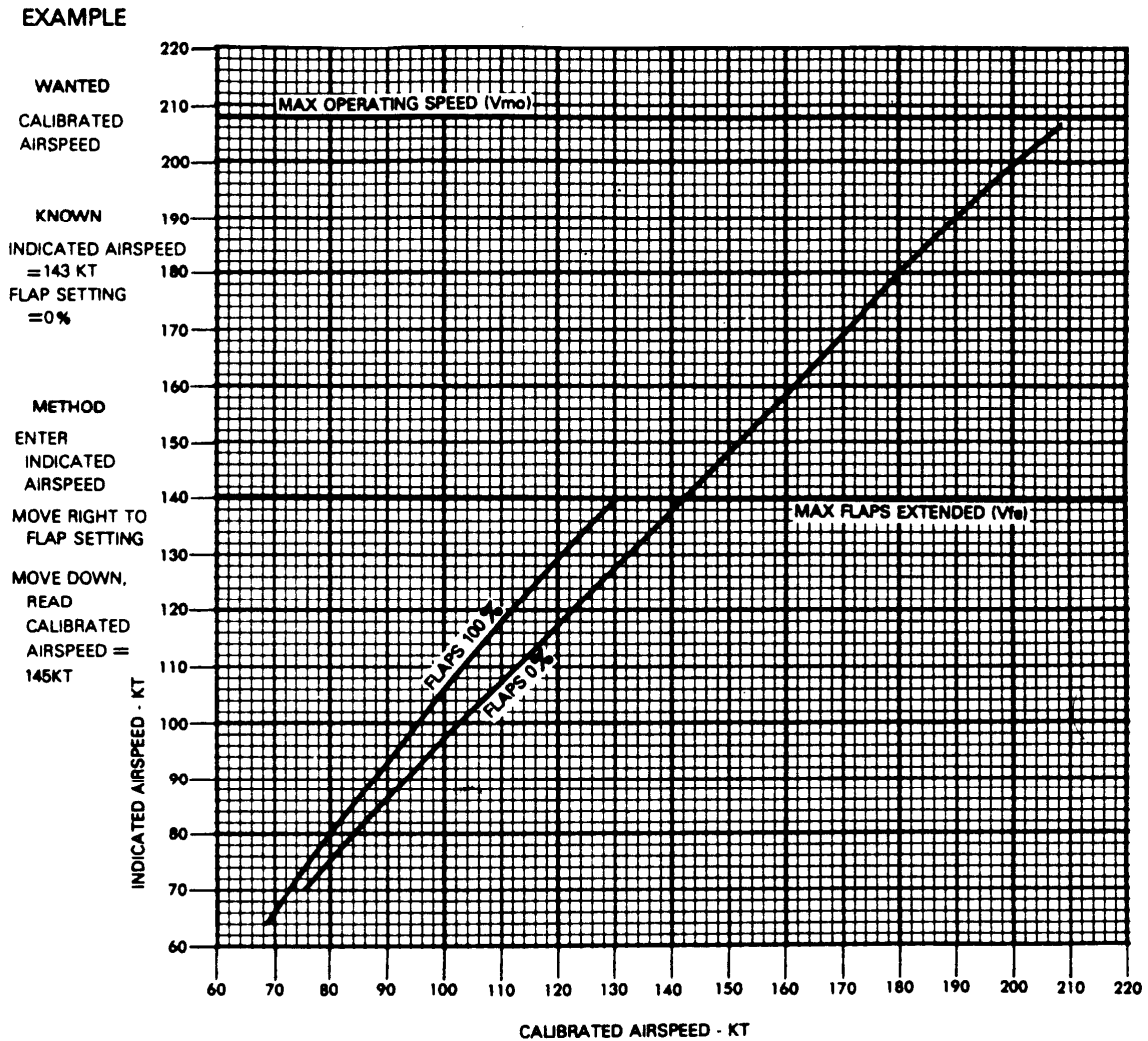

DATA BASIS: DERIVED FROM FLIGHT TEST

FIGURE 32. Airspeed calibration chart (sheet 1 of 2)

MIL-PRF-63029J

**ALTIMETER CORRECTION - NORMAL SYSTEM**

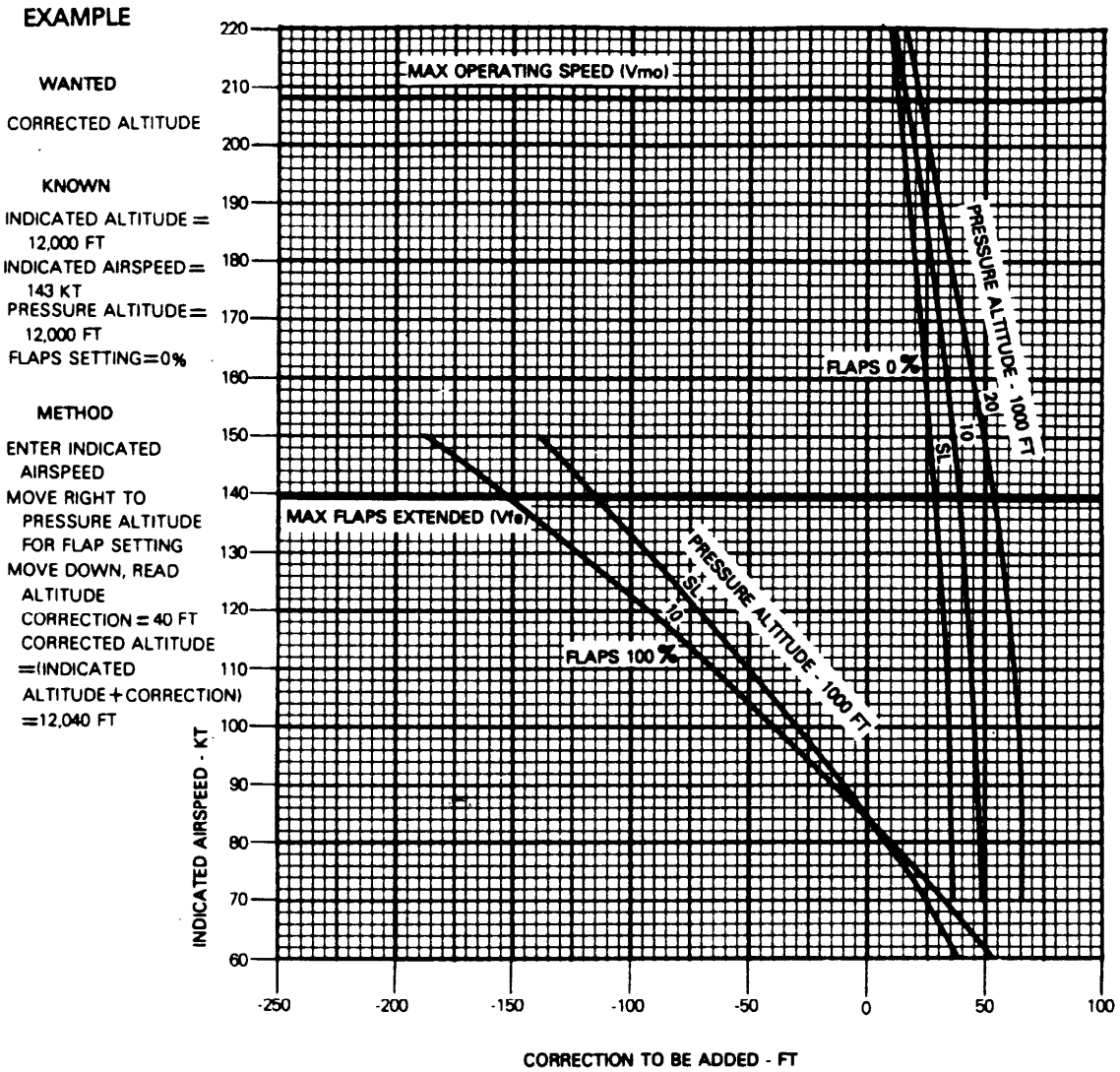

DATA BASIS: DERIVED FROM FLIGHT TEST

FIGURE 32. Airspeed-altimeter correction chart (sheet 2 of 2)

MIL-PRF-63029J

**AIRSPEED CALIBRATION**

**EXAMPLE**

**WANTED**  
CALIBRATED AIRSPEED

**KNOWN**  
INDICATED AIRSPEED = 70 KNOTS  
FLIGHT CONDITION = LEVEL FLIGHT

**METHOD**  
ENTER INDICATED AIRSPEED HERE  
MOVE RIGHT TO FLIGHT CONDITION  
MOVE DOWN, READ CALIBRATED AIRSPEED = 74.2 KNOTS

AIRSPEED CH-47D (2) T55-GA-714A
---------------------------------------

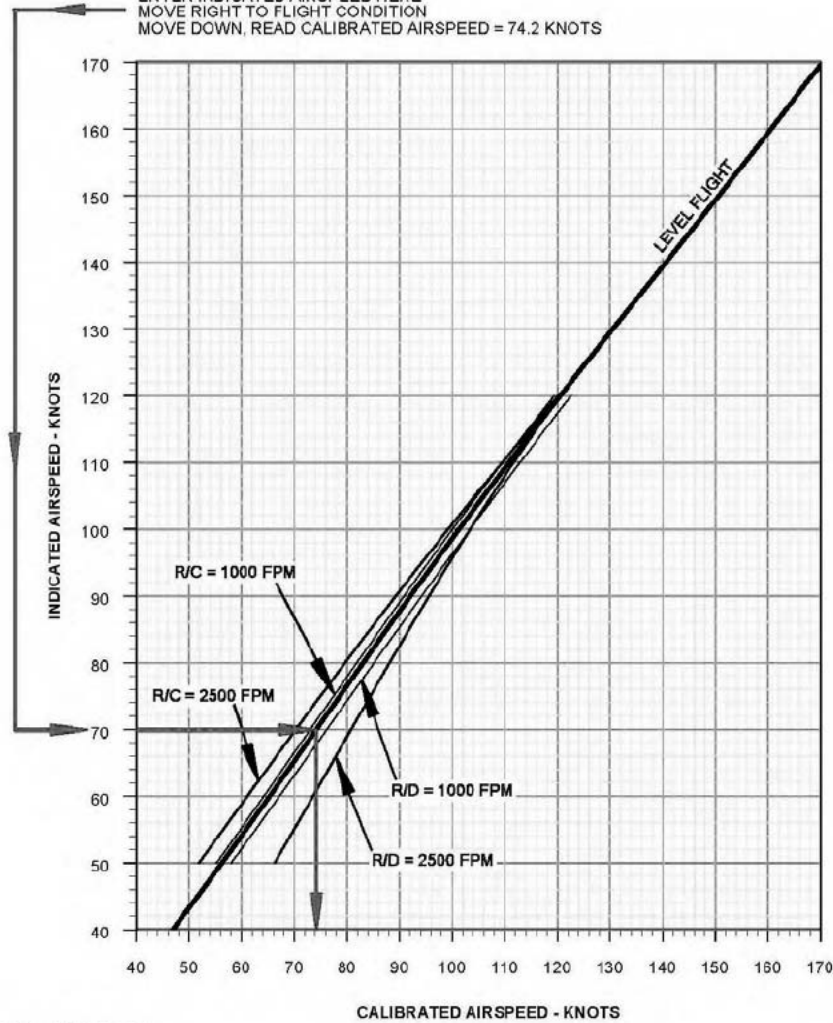

DATA BASIS: FLIGHT TEST

FPMv4.2.0.7

**FIGURE 33. Airspeed calibration chart**

MIL-PRF-63029J

# AIRSPEED SYSTEM CORRECTION

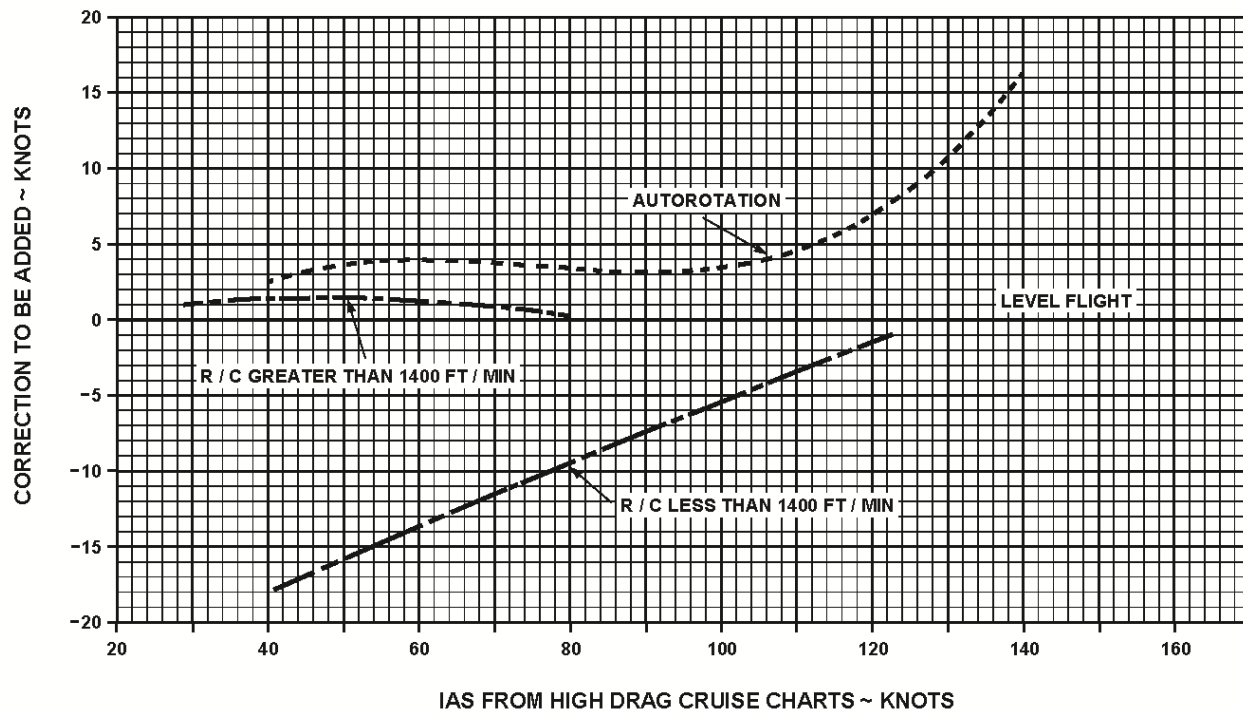

DATA BASIS: FLIGHT TEST

AA1029A  
SA

FIGURE 34. Airspeed correction chart (rotary wing) (sheet 1 of 2)

## MIL-PRF-63029J

TM 1-1520-280-10

## AIRSPEED SYSTEM CORRECTION

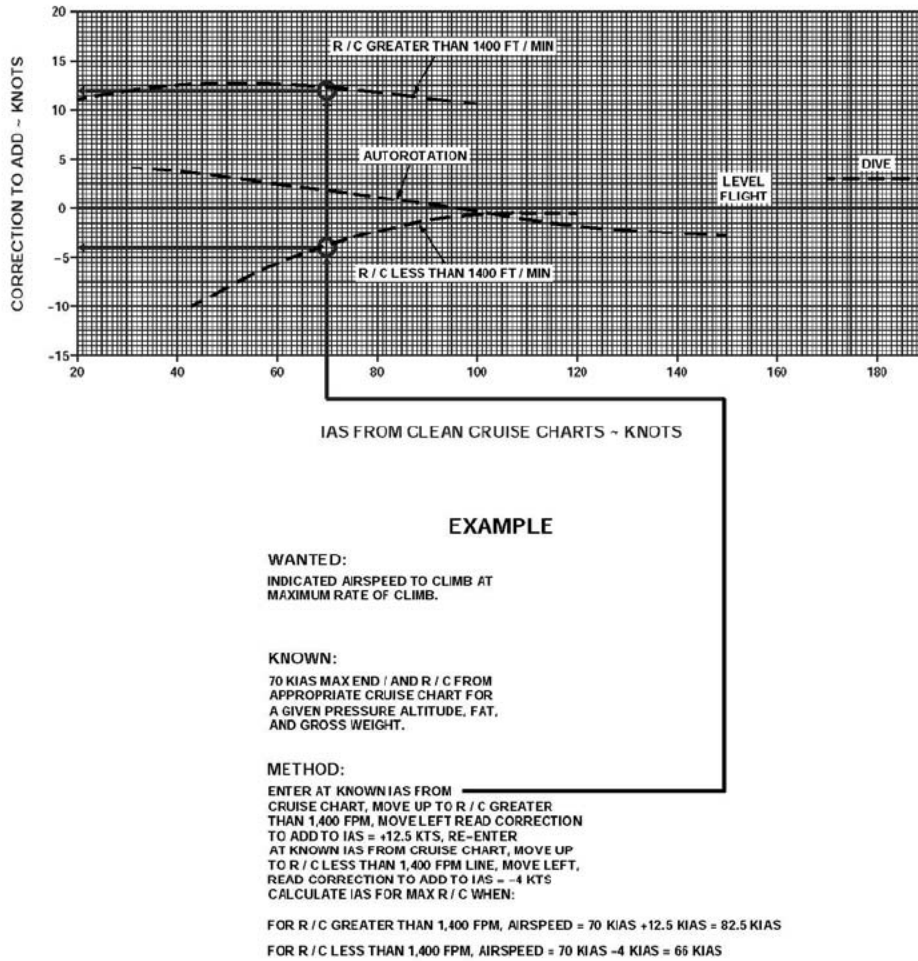

DATA BASIS: FLIGHT TEST

AM4425  
5A

FIGURE 34. Airspeed correction chart (sheet 2 of 2)



MIL-PRF-63029J

## CROSSWIND - TAKEOFF OR LANDING

## EXAMPLE

## KNOWN

CLEAN CONFIGURATION  
 RUNWAY 21  
 WIND VELOCITY = 23KT  
 WIND DIRECTION = 190°  
 NORMAL ROTATION AIRSPEED = 93KT

## METHOD

DETERMINE RUNWAY WIND ANGLE,  
 $210^\circ - 190^\circ = 20^\circ$   
 ENTER WIND VELOCITY  
 MOVE RIGHT TO RUNWAY WIND  
 ANGLE =  $20^\circ$   
 MOVE DOWN TO NORMAL ROTATION  
 AIRSPEED LINE = 93 KTS  
 THE INTERSECTION FALLS WITHIN THE  
 RECOMMENDED AREA

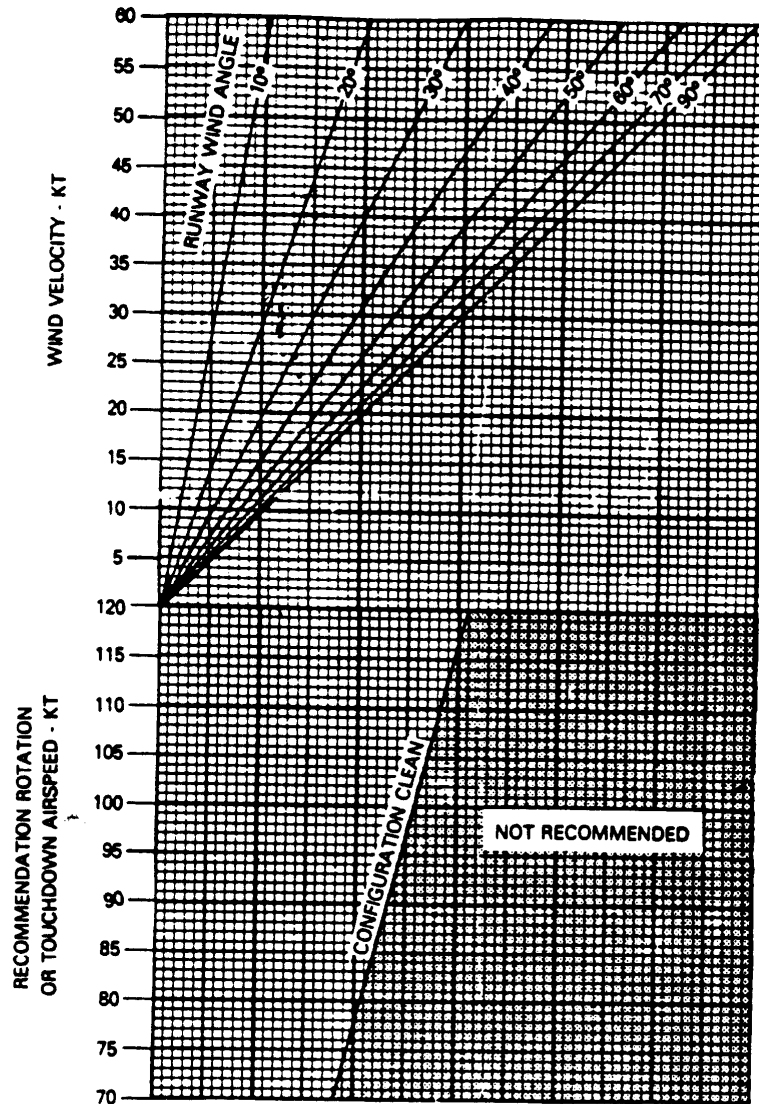

DATA BASIS: FLIGHT TEST

FIGURE 35. Crosswind takeoff or landing chart (FW)

MIL-PRF-63029J

### TORQUE AVAILABLE FOR TAKEOFF

PROP SPEED 2200 RPM  
FUEL JP-4 AIRSPEED 0 KNOTS

**EXAMPLE**

**WANTED**

TORQUE AVAILABLE FOR TAKEOFF

**KNOWN**

FAT=12°C  
PRESSURE ALTITUDE=4307 FT

**METHOD**

ENTER FAT  
MOVE RIGHT TO PRESSURE ALTITUDE=4307 FT  
MOVE DOWN, READ TORQUE AVAILABLE PER ENGINE=1159 FT-LB

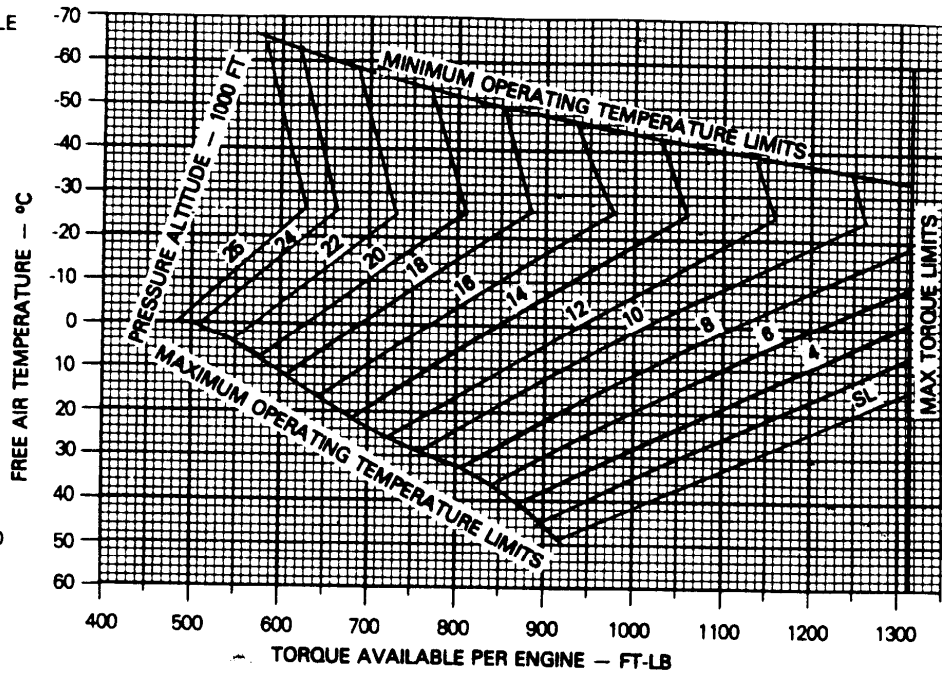

DATA BASIS: CALCULATED FROM ENGINE MODEL SPEC .

FIGURE 36. Torque available for takeoff chart (FW)

MIL-PRF-63029J

### TAKEOFF - NORMAL

CALM WINDS FLAPS 0 PERCENT POWER - TAKEOFF  
LEVEL HARD SURFACE

#### EXAMPLE

##### WANTED

REQUIRED GROUND ROLL AND OBSTACLE  
CLEARANCE DISTANCES

##### KNOWN

FAT = 12°C  
PRESSURE ALTITUDE = 4307 FT  
TAKEOFF WEIGHT = 9650 LB  
OBSTACLE HEIGHT = 71 FT

##### METHOD

ENTER FAT  
MOVE RIGHT TO PRESSURE ALTITUDE = 4307 FT  
MOVE DOWN TO TAKEOFF WEIGHT = 9650 LB  
MOVE LEFT TO OBSTACLE HEIGHT = 71 FT  
MOVE DOWN, READ TOTAL DISTANCE REQUIRED  
TO CLEAR OBSTACLE = 4375 FT  
MOVE LEFT TO OBSTACLE HEIGHT = 0 FT  
MOVE DOWN, READ GROUND ROLL DISTANCE  
= 2725 FT

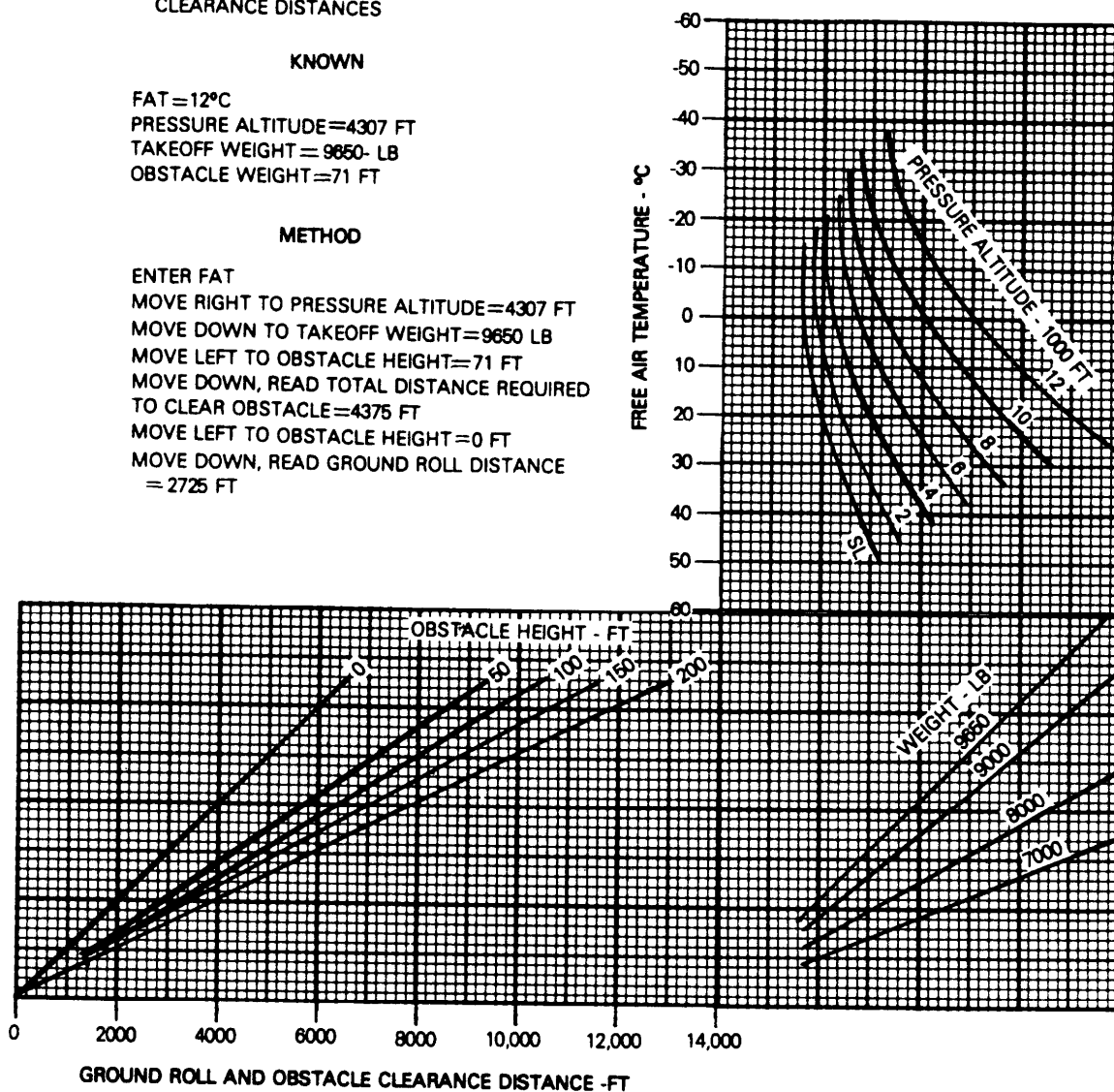

DATA BASIS: CALCULATED

FIGURE 37. Takeoff — normal chart (FW)

MIL-PRF-63029J

## NORMAL ROTATION/TAKEOFF AIRSPEED FLAPS 0 PERCENT

### EXAMPLE

#### WANTED

NORMAL ROTATION, TAKEOFF, AND OBSTACLE  
CLEARANCE AIRSPEEDS FOR KNOWN TAKEOFF  
WEIGHT

#### KNOWN

TAKEOFF WEIGHT = 9650 LBM

#### METHOD

ENTER TAKEOFF WEIGHT  
MOVE RIGHT TO ROTATION AIRSPEED. TAKEOFF  
AIRSPEED AND OBSTACLE CLEARANCE  
AIRSPEED LINES  
MOVE DOWN FROM ROTATION AIRSPEED LINE  
READ INDICATED AIRSPEED FOR ROTATION 96 KT  
MOVE DOWN FROM TAKEOFF AIRSPEED LINE,  
READ INDICATED AIRSPEED FOR TAKEOFF 99 KT  
MOVE DOWN FROM OBSTACLE CLEARANCE  
AIRSPEED LINE, READ INDICATED AIRSPEED  
FOR OBSTACLE CLEARANCE 110 KT

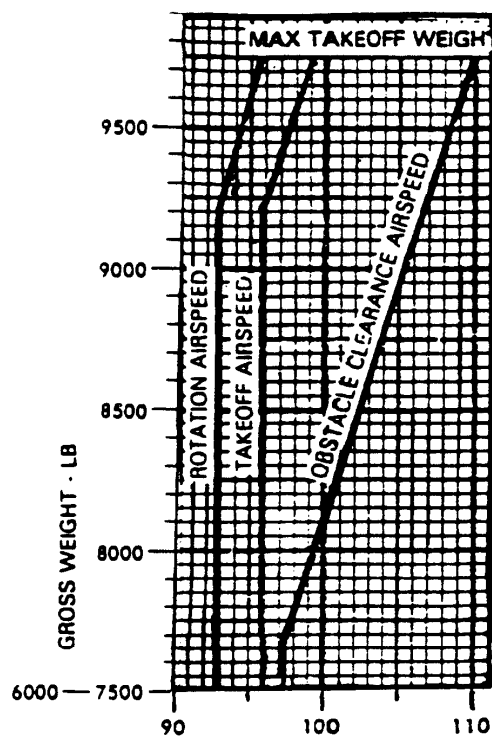

**DATA BASIS:** FLIGHT TEST

**FIGURE 38.** Normal rotation / takeoff airspeed chart (FW)

MIL-PRF-63029J

# ACCELERATION CHECK

POWER - TAKEOFF CALM WINDS  
 FLAPS 0 PERCENT LEVEL HARD SURFACE

ACCELERATION  
 CHECK  
 RU-21D  
 T74-CP-700

## EXAMPLE

### WANTED

AIRSPED REQUIRED AT  
 VARIOUS ACCELERATION  
 CHECK POINTS

### KNOWN

TAKEOFF AIRSPED FOR  
 KNOWN GROSS WEIGHT  
 OF 9,650 LB = 96 KT  
 GROUND ROLL DISTANCE  
 = 2500 FT

### METHOD

ENTER INDICATED  
 AIR SPEED HERE  
 MOVE RIGHT TO GROUND  
 ROLL DISTANCE LINE  
 = 2500 FT  
 MOVE DOWN THE GUIDE  
 LINE TO THE 1000 FT  
 GROUND ROLL DISTANCE  
 LINE  
 MOVE LEFT, READ INDICATED  
 AIRSPED REQUIRED AT  
 1000 FT MARKER = 57 KT

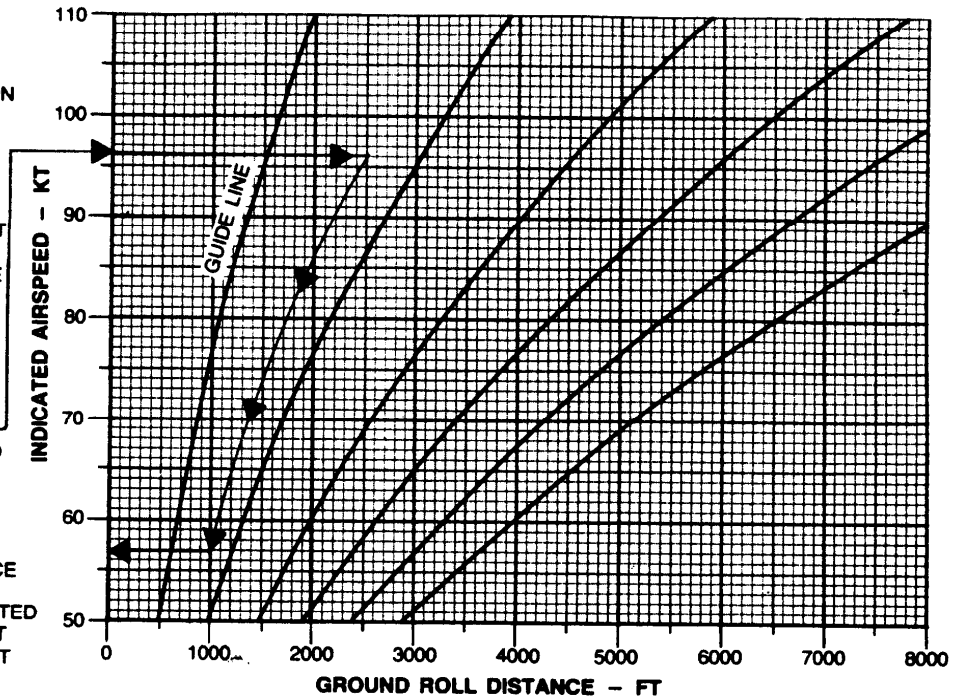

DATA BASIS: ESTIMATED

G  
 AP 001539

FIGURE 39. Acceleration check distance chart (FW)

MIL-PRF-63029J

**ACCELERATE-STOP DISTANCE**  
 CALM WINDS FLAPS 0 PERCENT POWER-TAKEOFF  
 LEVEL HARD SURFACE

**ACCELERATE-STOP**  
**RU-21D**  
**T74-CP-700**

**EXAMPLE**

**WANTED**

DISTANCE REQUIRED TO ACCELERATE TO TAKEOFF AIRSPEED,  
 THEN STOP

**KNOWN**

FAT = 12°C  
 PRESSURE ALTITUDE = 4307 FT.  
 TAKEOFF WEIGHT = 9650 LB

**METHOD**

ENTER FAT HERE →  
 MOVE RIGHT TO PRESSURE ALTITUDE = 4307 FT.  
 MOVE DOWN TO TAKEOFF WEIGHT = 9650 LB.  
 MOVE LEFT TO ACCELERATE-STOP DIST. = 5050 FT.

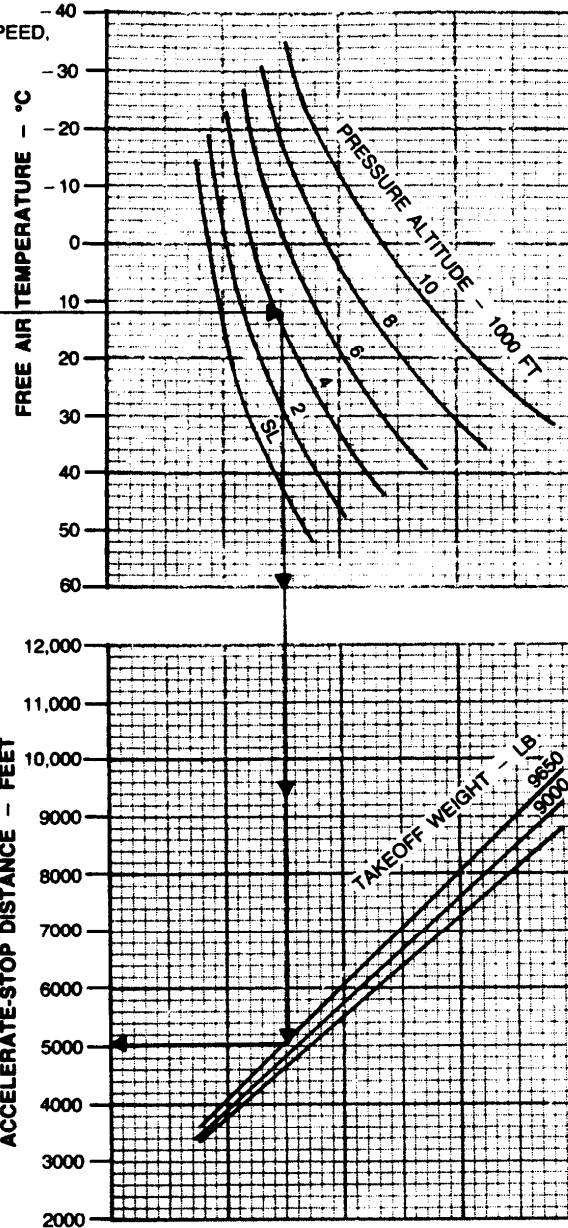

DATA BASIS: ESTIMATED

G  
 AP 003224

FIGURE 40. Accelerate – stop distance chart (FW)

MIL-PRF-63029J

**Accelerate After Lift-Off  
Flaps 40°  
Power 100%**

**EXAMPLE**

**WANTED**

GROUND ROLL DISTANCE AND  
TOTAL DISTANCE OVER 50 FT,  
OBSTACLE.

**KNOWN**

FREE AIR TEMPERATURE — 25°C  
PRESSURE ALTITUDE — 3966 FT.  
HEADWIND COMPONENT — 9.5 KTS  
GROSS WEIGHT — 12500 LBS.

**METHOD**

ENTER AT FAT  
MOVE RIGHT TO PRESSURE ALTITUDE  
MOVE DOWN TO 1ST REF. LINE  
FOLLOW GUIDE LINE TO GROSS WEIGHT  
MOVE DOWN TO 2ND REF. LINE  
FOLLOW GUIDE LINE TO WIND SPEED  
MOVE DOWN TO 3RD REF. LINE  
CONTINUE STRAIGHT DOWN  
READ GROUND ROLL EQUAL 3300 FT.  
FOLLOW GUIDE LINE TO 50 FT  
READ TOTAL DISTANCE EQUAL 8550 FT.

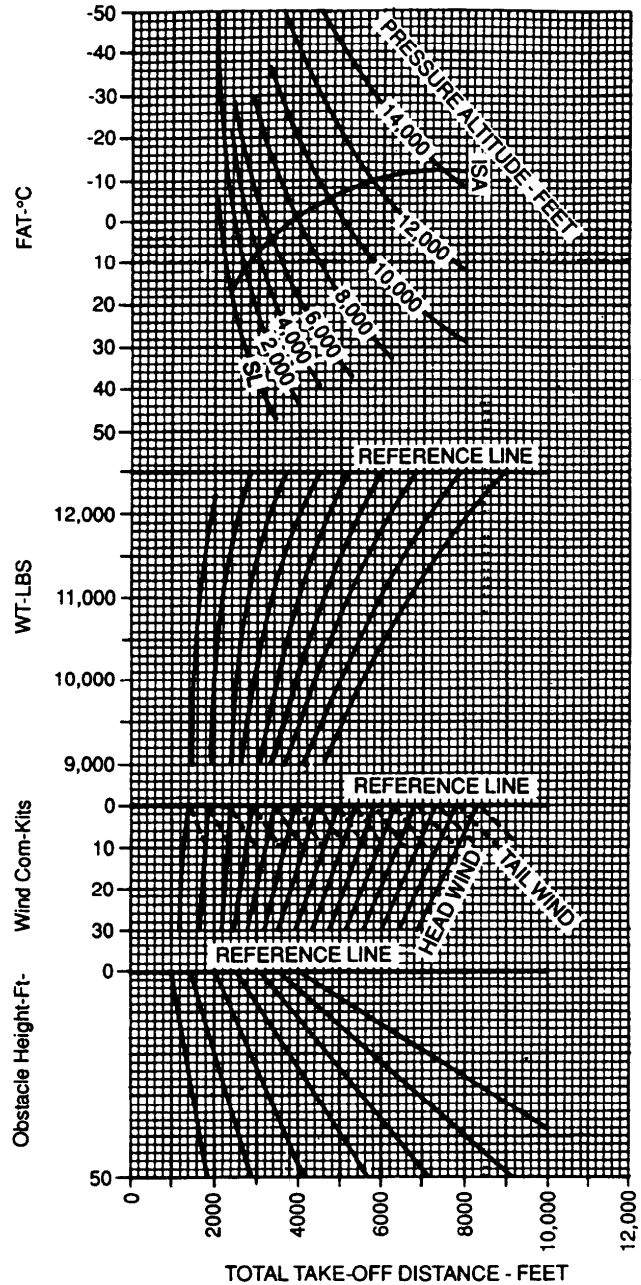

FIGURE 41. Accelerate after lift-off chart (FW)

MIL-PRF-63029J



# MINIMUM SINGLE ENGINE CONTROL AIRSPEED (V<sub>mc</sub>)

POWER - TAKEOFF GEAR DOWN  
FLAPS 0 PERCENT PROP FEATHERED

MINIMUM SINGLE ENGINE CONTROL AIRSPEED  
RU-21D  
T74-CP-700

## EXAMPLE

### WANTED

MINIMUM SINGLE ENGINE CONTROL AIRSPEED  
AT A GIVEN FAT AND PRESSURE ALTITUDE

### KNOWN

FAT = 12°C  
PRESSURE ALTITUDE = 4307 FT

### METHOD

ENTER FAT HERE →  
MOVE RIGHT TO PRESSURE ALTITUDE = 4307  
FT  
MOVE DOWN TO RUDDER LIMITED LINE  
MOVE LEFT, READ MINIMUM CONTROL INDICATED AIRSPEED = 84 KNOTS

### NOTE

AT SOME WEIGHTS A STALL CONDITION CAN OCCUR AT AIRSPEEDS HIGHER THAN THE RUDDER LIMITED V<sub>mc</sub>

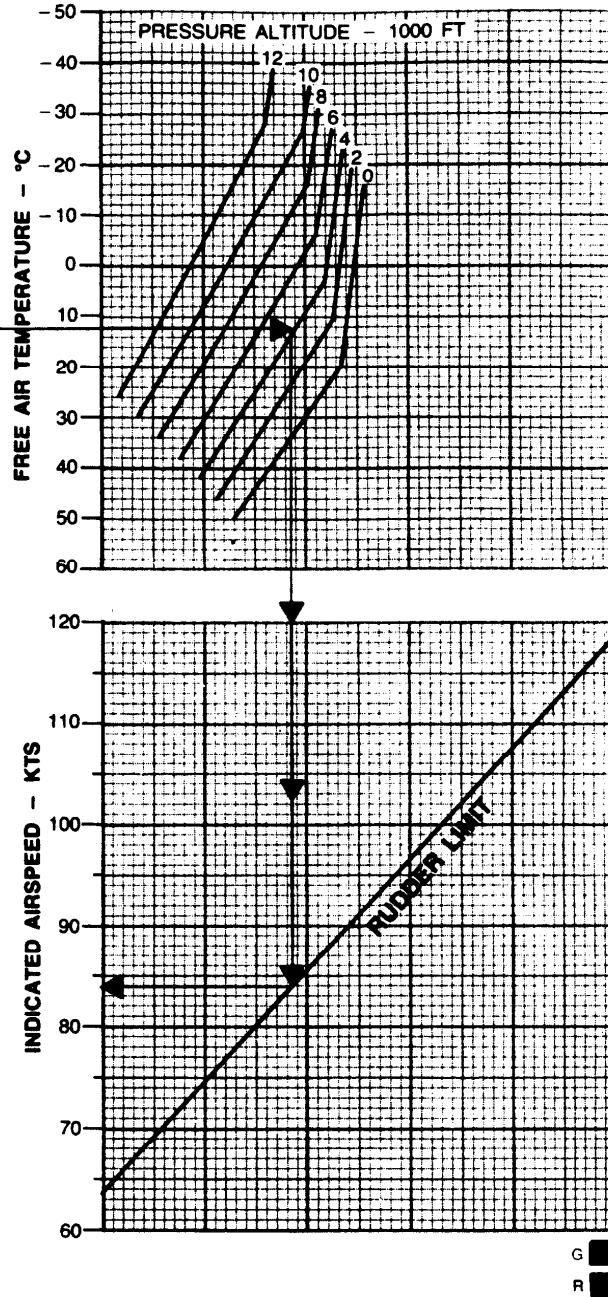

G  
R

DATA BASIS: FLIGHT TEST

AP 004559

FIGURE 42. Minimum single engine control airspeed chart (FW)



MIL-PRF-63029J



# SINGLE ENGINE CLIMB TAKEOFF CONFIGURATION

SINGLE-ENGINE CLIMB  
RU-21D  
T74-CP-700

FLAPS 0 PERCENT PROPELLER FEATHERED POWER - TAKEOFF

## EXAMPLE

### WANTED

WEIGHT TO OBTAIN A POSITIVE SINGLE ENGINE  
R/C AT LIFTOFF AND SINGLE ENGINE  
R/C AFTER THE GEAR IS RETRACTED

### KNOWN

FAT = 12°C  
PRESSURE ALTITUDE = 4307 FT

### METHOD

ENTER FAT HERE →  
MOVE RIGHT TO PRESSURE ALTITUDE =  
4307 FT  
MOVE DOWN TO 0 FT/MIN R/C FOR GEAR  
DOWN, READ WEIGHT TO OBTAIN POSITIVE  
R/C AT LIFTOFF = 9650 LB  
MOVE DOWN TO WEIGHT = 9650 LB FOR  
GEAR UP CLIMB  
MOVE LEFT READ SINGLE ENGINE R/C AFTER  
GEAR RETRACTION = 175 FT/MIN

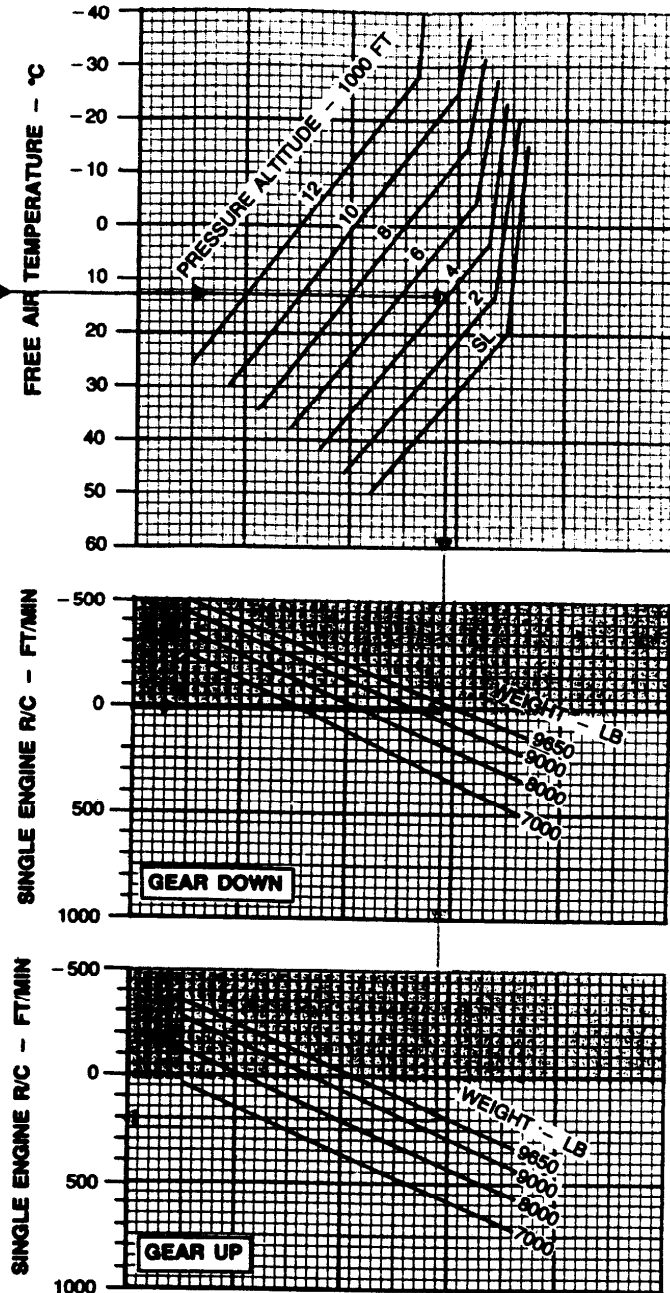

DATA BASIS: CALCULATED

AP 001389

FIGURE 43. Single engine climb chart (FW) (sheet 1 of 2)

MIL-PRF-63029J

**Single Engine Gradient of Climb**  
**Flaps 40%**  
**Power - 100%**  
**Landing Gear-Up**

**EXAMPLE**

**WANTED**

GRADIENT OF CLIMB

**KNOWN**

FREE AIR TEMPERATURE — 25°C  
 PRESSURE ALTITUDE — 3966 FT.  
 GROSS WEIGHT — 12150 LBS

**METHOD**

ENTER AT FAT  
 MOVE RIGHT TO PRESSURE ALTITUDE  
 MOVE DOWN TO REFERENCE LINE  
 FOLLOW GUIDE LINE TO GROSS WEIGHT  
 MOVE DOWN READ GRADIENT OF CLIMB  
 EQUAL 2.4%

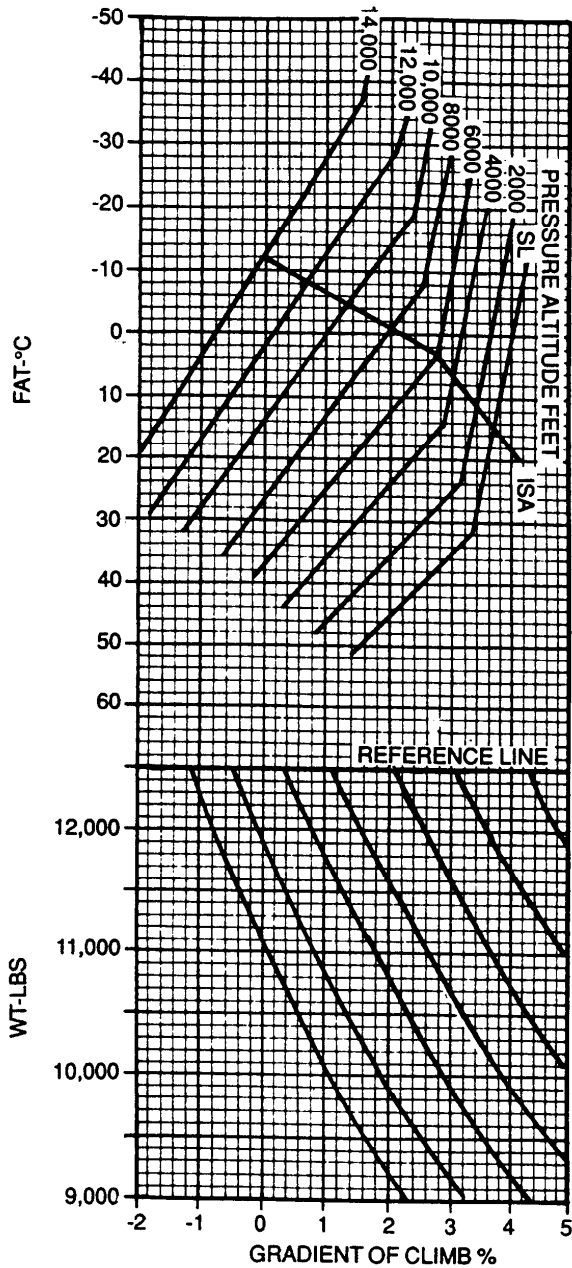

FIGURE 43. Single engine climb chart (FW) (sheet 2 of 2)

MIL-PRF-63029J

### CRUISE CLIMB

GEAR UP FLAPS 0 PERCENT CALM WIND  
POWER - MAXIMUM CRUISE CLIMB

**CRUISE CLIMB**  
**RU-21D**  
**T74-CP-700**

#### EXAMPLE

##### WANTED

TIME, FUEL AND DISTANCE REQUIRED TO CLIMB

##### KNOWN

INITIAL FAT = 12°C  
INITIAL PRESSURE ALTITUDE = 4307 FT  
INITIAL WEIGHT = 9650 LBS  
FINAL FAT = -5°C  
FINAL PRESSURE ALTITUDE = 12,000 FT

##### METHOD

ENTER FAT HERE →  
MOVE RIGHT TO PRESSURE ALTITUDE →  
MOVE DOWN TO INITIAL WEIGHT →  
MOVE LEFT, READ TIME, FUEL AND DISTANCE ←

##### NOTE

READ GRAPH FOR INITIAL CONDITIONS. SECONDLY, READ FOR FINAL CONDITIONS WITH INITIAL WEIGHT. DIFFERENCE BETWEEN READINGS IS TIME, FUEL AND DISTANCE TO CLIMB.  
TIME TO CLIMB (10-3) = 7 MIN  
FUEL TO CLIMB (100-32) = 68 LB  
DISTANCE TO CLIMB (20-6) = 14 N. M.

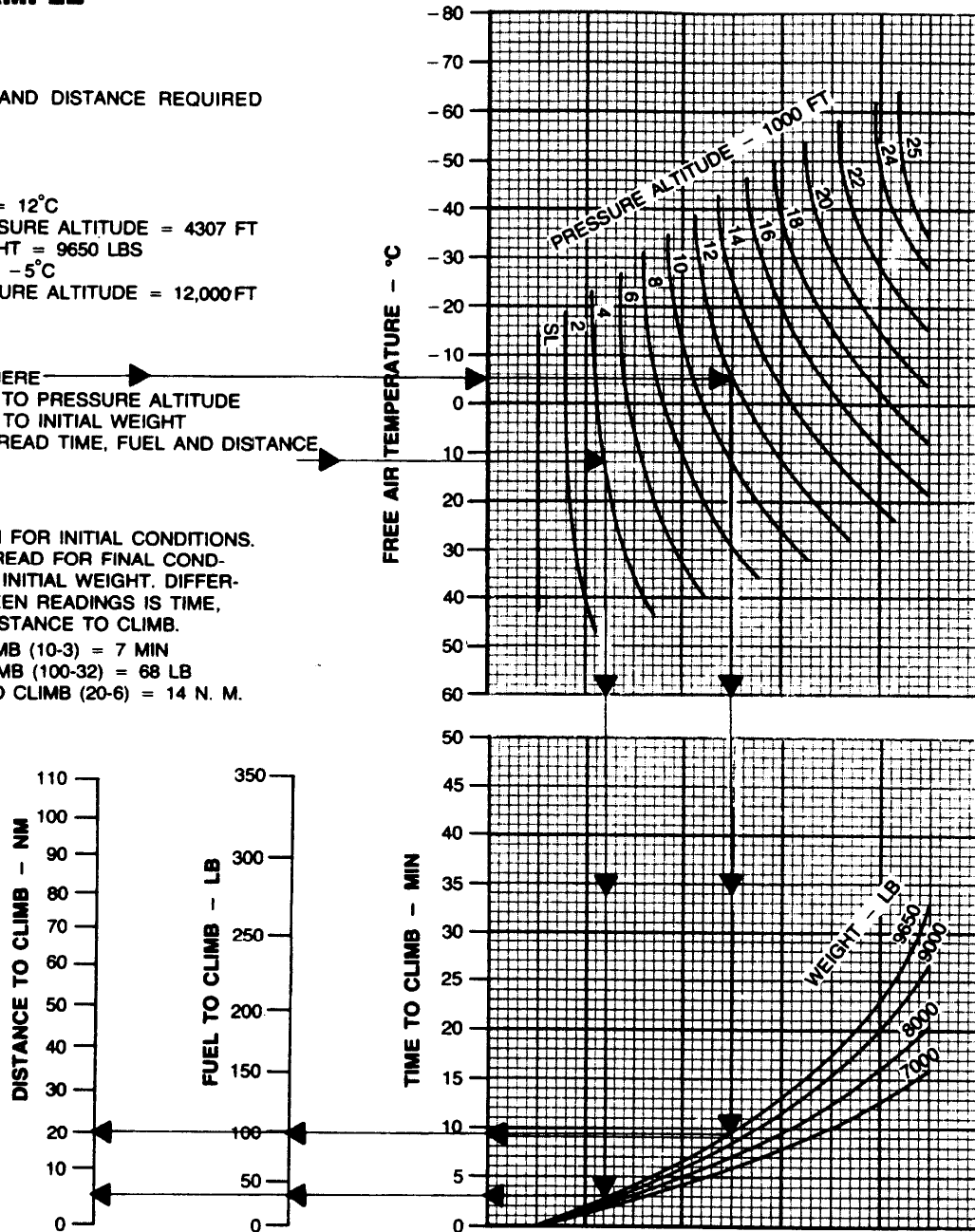

DATA BASIS: FLIGHT TEST

G  
AP 001391

FIGURE 44. Cruise climb chart

MIL-PRF-63029J

FAT 30°C

**CRUISE**  
 TWIN ENGINE  
 RPM-1900  
 PRESSURE ALTITUDE 8000 FEET  
 FLAPS 0 PERCENT FUEL JP-4 GEAR UP  
 Fuel Flow Per Engine-LB/HR

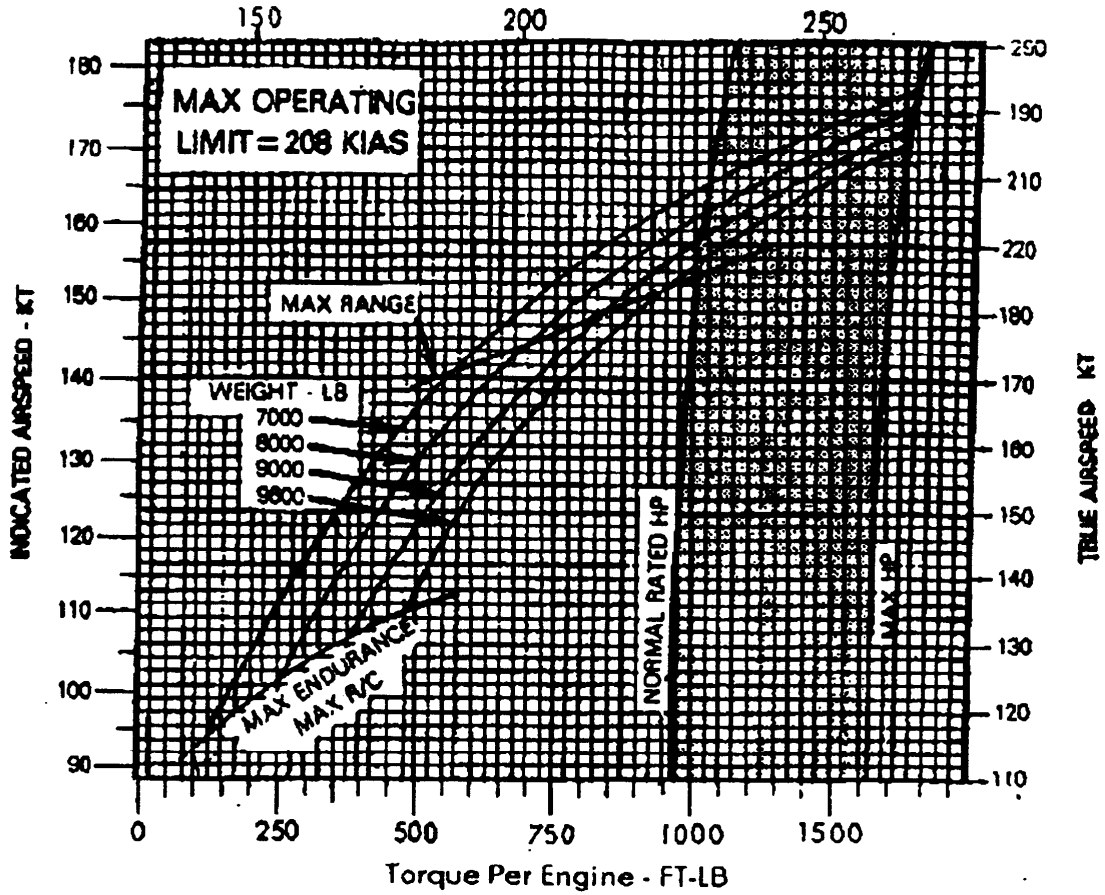

FIGURE 45. Cruise chart (FW)

MIL-PRF-63029J



### CLIMB/DESCENT

**CLIMB/DESCENT  
RU-21D  
T74-CP-702**

#### EXAMPLE

**WANTED**  
RATE OF CLIMB OR DESCENT AS A  
RESULT OF CHANGE IN HORSEPOWER

**KNOWN**  
HORSEPOWER CHANGE = 200 HP  
WEIGHT = 9000 LB

**METHOD**  
ENTER HORSEPOWER CHANGE HERE  
MOVE RIGHT TO WEIGHT = 9000 LB  
MOVE DOWN, READ RATE OF CLIMB  
OR DESCENT = 1050 FT/MIN

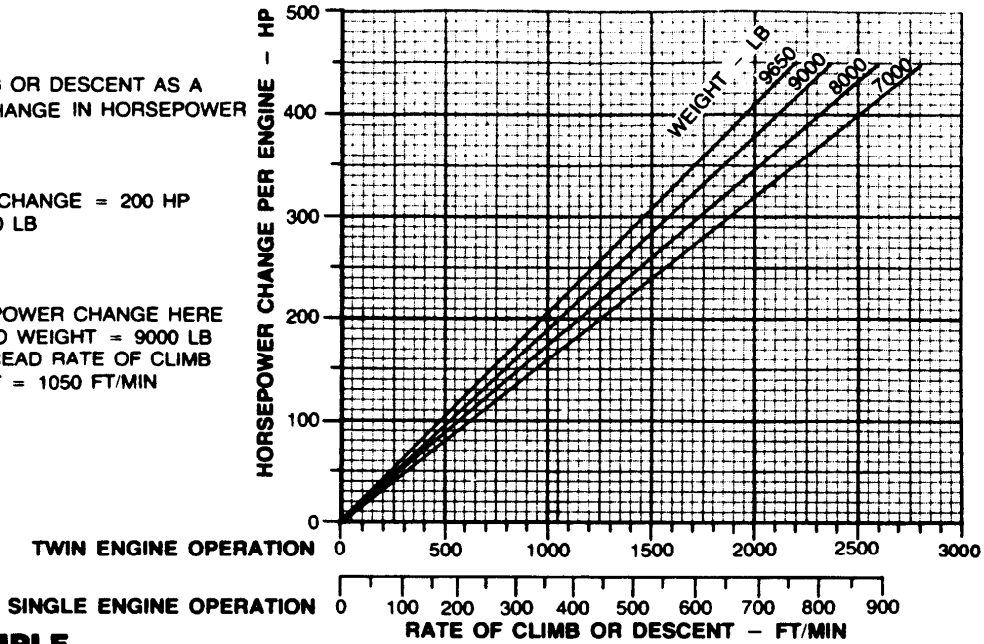

**WANTED**  
TORQUE CHANGE FOR CLIMB OR DESCENT  
AS A RESULT OF CHANGE IN  
HORSEPOWER OR RPM

**KNOWN**  
HORSEPOWER CHANGE = 200  
PROP RPM = 1900 RPM

**METHOD**  
ENTER HORSEPOWER CHANGE HERE  
MOVE RIGHT TO RPM = 1900 RPM  
MOVE DOWN, READ TORQUE CHANGE  
PER ENGINE = 560 FT LB

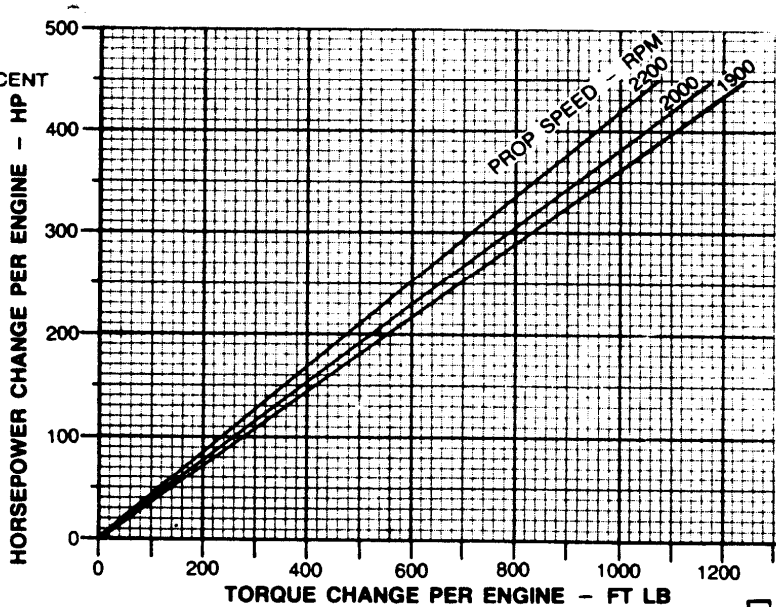

DATA BASIS: CALCULATED

AP 001418

FIGURE 46. Climb/descent chart (FW)

MIL-PRF-63029J

# APPROACH SPEED

GEAR DOWN

## EXAMPLE

**WANTED**  
RECOMMENDED APPROACH SPEED  
FOR KNOWN WEIGHT

**KNOWN**  
WEIGHT=8855 LB  
FLAP SETTING=DOWN

**METHOD**  
ENTER WEIGHT  
MOVE RIGHT TO APPROACH SPEED  
LINE, FLAPS DOWN  
MOVE DOWN, READ INDICATED  
AIRSPEED=103 KT

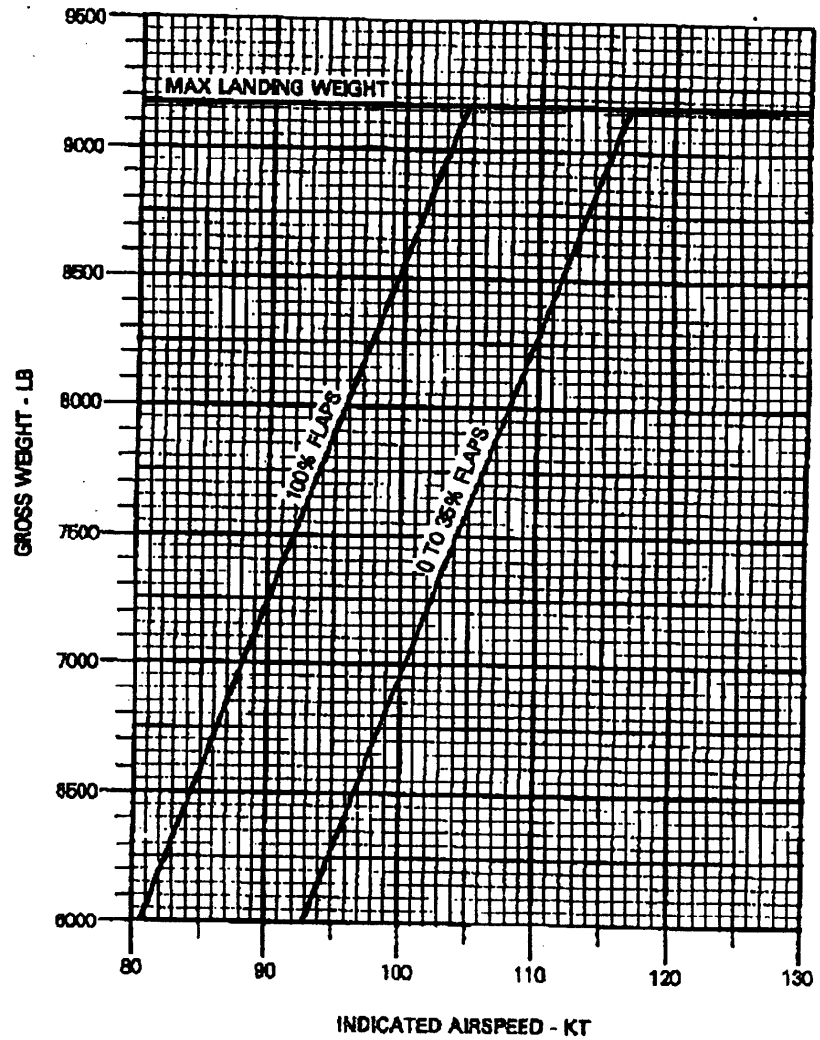

DATA BASIS: FLIGHT TEST

FIGURE 47. Approach speed chart (FW)

MIL-PRF-63029J

# LANDING

CALM WINDS LEVEL, DRY, HARD SURFACE  
MAX BRAKING AND IDLE POWER ON RUNWAY

## EXAMPLE

### WANTED

LANDING DISTANCE

### KNOWN

WEIGHT - 8855 LB  
PRESSURE ALTITUDE - 4484 FT  
FAT - 18°C  
FLAPS DOWN

### METHOD

ENTER FAT  
MOVE RIGHT TO PRESSURE ALTITUDE - 4484 FT  
MOVE DOWN TO WEIGHT - 8855 LB  
MOVE LEFT TO FULL BRAKING WITH FLAPS DOWN  
MOVE STRAIGHT DOWN, READ LANDING DISTANCE - 2180 FT

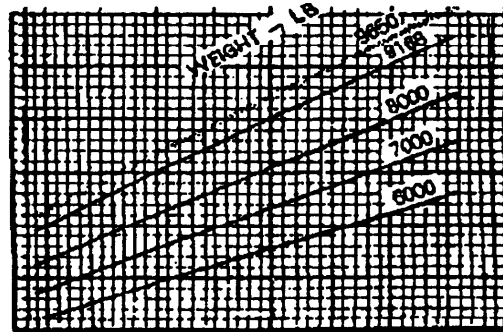
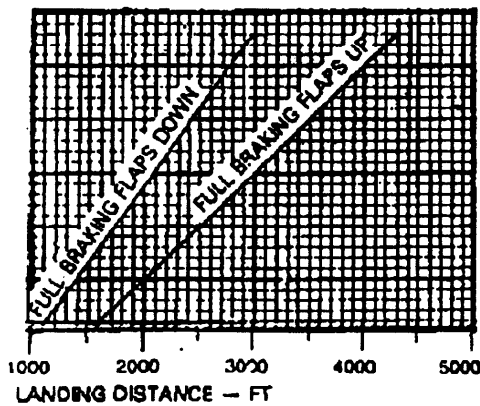
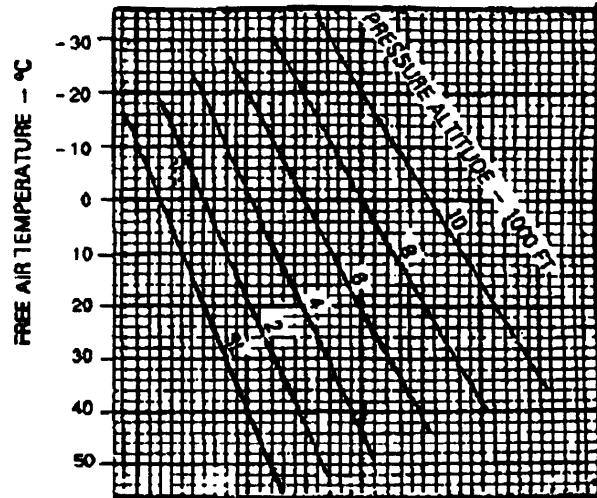

DATA BASIS: CALCULATED

FIGURE 48. Landing chart (FW)

## MIL-PRF-63029J

TM 1-1520-123-10

## 8-12. Interior Check.

## a. Subpara1 Subordinate Sidehead

## (1) Subpara2 Subordinate Sidehead

## (a) Subpara3 Subordinate Sidehead

1 Subpara4 Subordinate Sidehead

## 8-13. Forward Cabin.

1. Flight control closet — Check actuators for extended jam buttons and thrust idler assemblies for bent cracked arms, pay particular attention to the area around the rigging pin hole. Check connecting link for cracks or displaced bearings.
- 2. Crew Chief Seat — Check condition and security.
3. Seats, litters, first aid kits, cargo and jettisonable cabin windows — Check condition and security.
4. Utility hatch door and lower rescue door — Check condition and position as required.
- 5. Radar Altimeter — Check condition, knob OFF, Dimming control OFF.

**WARNING**

Ensure roller is fully seated in locked position and hook is fully seated in cam lock or hook will release under loaded conditions.

**CAUTION**

When performing a combat mission or over-water mission, aviator worn gear can restrict head and torso movement. Users should conduct ground familiarity drills (blind switch/control identification) and crew coordination exercises before flight, since field of regard can be restricted by aviator worn mission equipment. The user must strictly adhere to proper crew coordination procedures during switch identification.

6. Center hook — Check condition and position as required. Check psi charge, manual release mechanisms stowed, manual release mechanism for proper cam position and latched.
7. Forward, center and aft manual hook release lever — Check for security and stowed.
8. **ABC** Cable unit — Check Condition.
- 9. Control boxes — Check condition and security.
- 10. Tank installed — Check the following:

- a. All fuel manifold lines, electrical lines, grounding cables, and vent lines to ensure that they are properly secured and connected.

## (1) CONTROL PANEL — Check or set as follows:

- (a) Electrical Receptacles to Fuel Control Panel — Check connection security.
- (b) Electrical Panel to Tank Assembly — Check connection security.
- (c) Wiring Harness — Check connection security.
  1. PANEL illumination switch — OFF.
  2. FUEL switch — Set to 1, 2, 3, and TOTAL to check fuel quantity in each tank (Aircraft power must be on to illuminate).

- b. Fuel manifold lines and tiedown straps for chafing. Tank tiedown straps for security.
- c. Ensure tanks are properly fueled.
- d. Check tanks for leakage.

## ○★ 11. Tank assembly installed — For each installed tank assembly check the following:

- Restraint Assembly — Check location and security.
- a. Drain — Check connection and security of drain in use. Check drain not in use capped.
  - b. Grounding Cable — Check connection security.
  - c. Vent Hose Assembly — Check connection security. Ensure dust cover is secure on retention strap and connection to dust cap stowage connector.
  - d. Fuel Transfer Hose Assembly — Check connection security; all Unisex valves OPEN.

**CAUTION**

Failure to close the unisex valves at the end of the single point pressure refueling hose assembly could allow suctioning of fuel from the main fuel tanks during operations.

- e. Hose Assembly — Check connection security; unisex valve at Tank CLOSE.
- f. Electrical Harness — Check connection security.

8-5

Change 1

FIGURE 49. Example of amplified checklist format and style (reduced in size to fit on page)



MIL-PRF-63029J

**CABIN EMERGENCY HATCH JETTISON PROCEDURE**

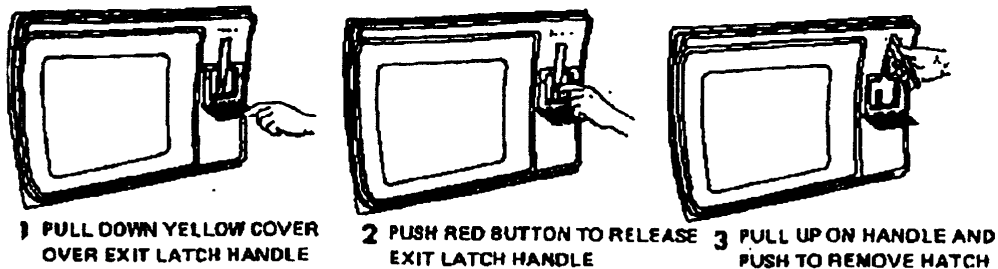

**EMERGENCY ESCAPE ROUTES**

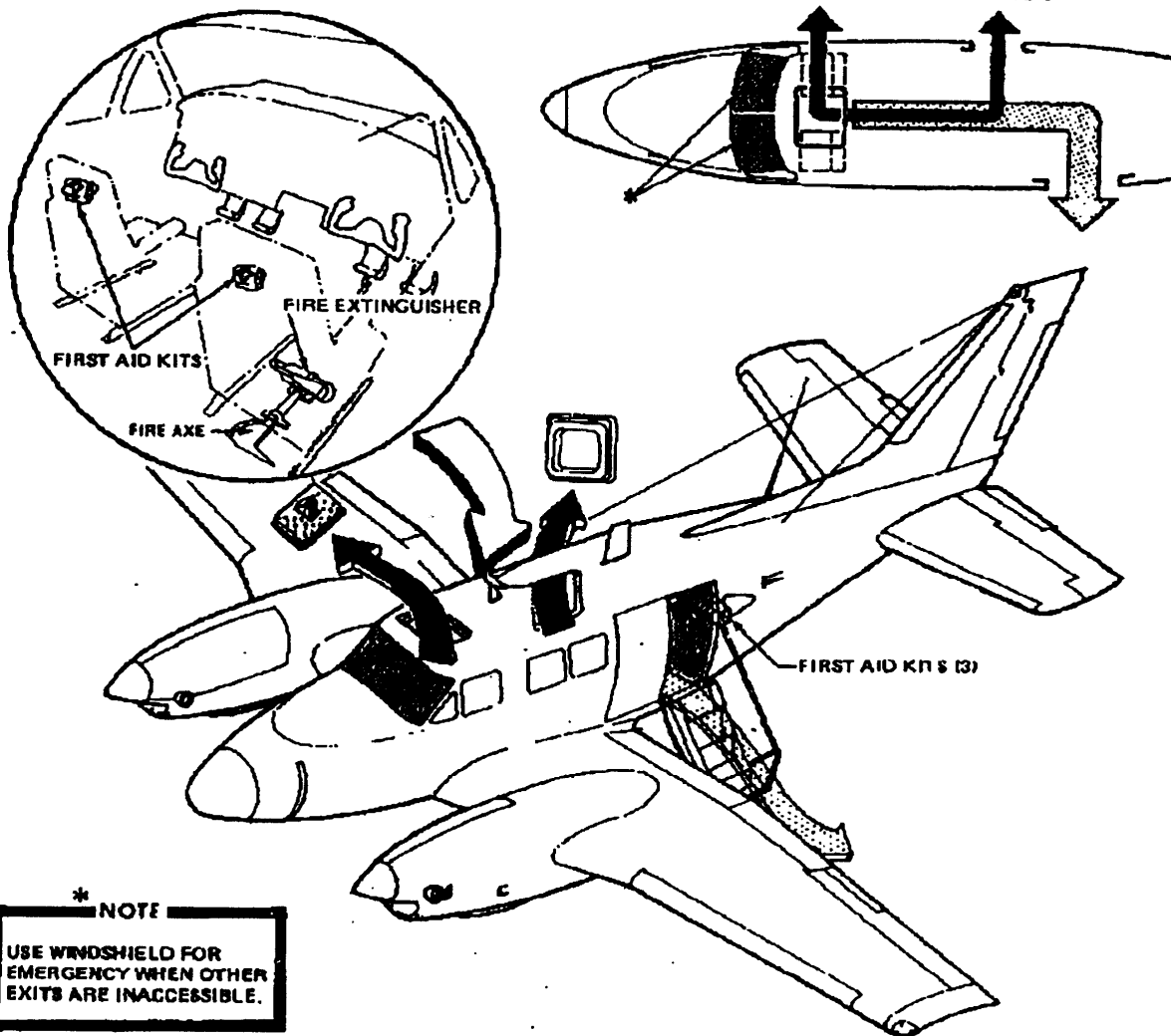

**\* NOTE**  
**USE WINDSHIELD FOR EMERGENCY WHEN OTHER EXITS ARE INACCESSIBLE.**

- DITCHING EMERGENCY EXITS AND EMERGENCY ENTRANCE ALL SERIES
- DITCHING AND GROUND EMERGENCY EXIT ONLY
- BAIL-OUT, DITCHING AND GROUND EMERGENCY EXIT

**FIGURE 50. Emergency equipment and emergency exits (sheet 1 of 2)**

MIL-PRF-63029J

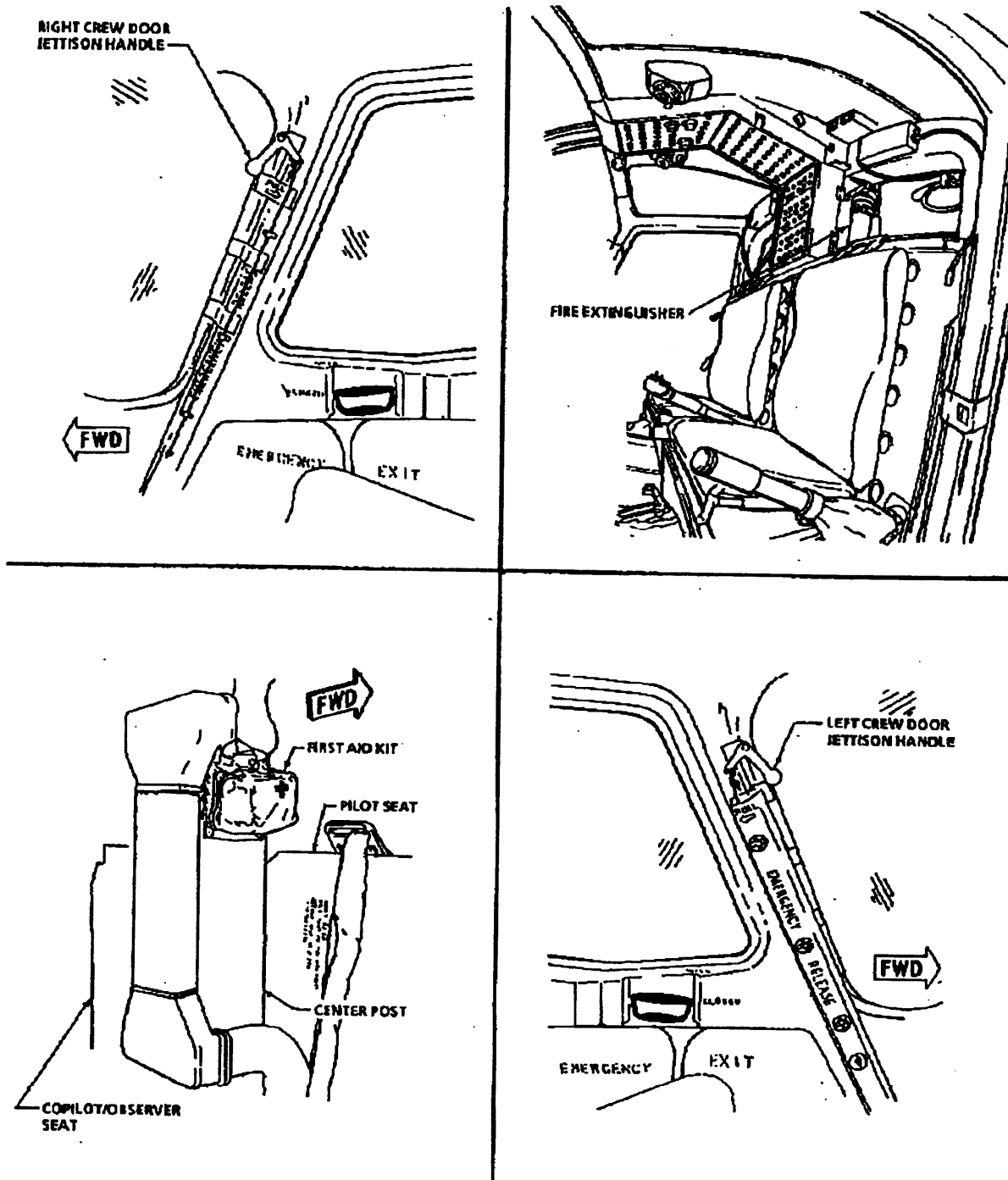

FIGURE 50. Emergency equipment and emergency exits (sheet 2 of 2)

MIL-PRF-63029J

# MAXIMUM GLIDE DISTANCE

POWER OFF (PROPELLERS FEATHERED)  
GEAR AND FLAPS UP ZERO WIND

WEIGHT - LBS.	BEST GLIDE SPEED KIAS
9650	112
9000	108
8000	102
7000	94
6000	87

## EXAMPLE

**WANTED**  
MAXIMUM GLIDE DISTANCE

**KNOWN**  
HEIGHT ABOVE TERRAIN = 7400 FT

**METHOD**  
ENTER HEIGHT ABOVE TERRAIN  
MOVE RIGHT TO MAXIMUM GLIDE  
DISTANCE LINE  
MOVE DOWN, READ MAXIMUM  
GLIDE DISTANCE = 22NM

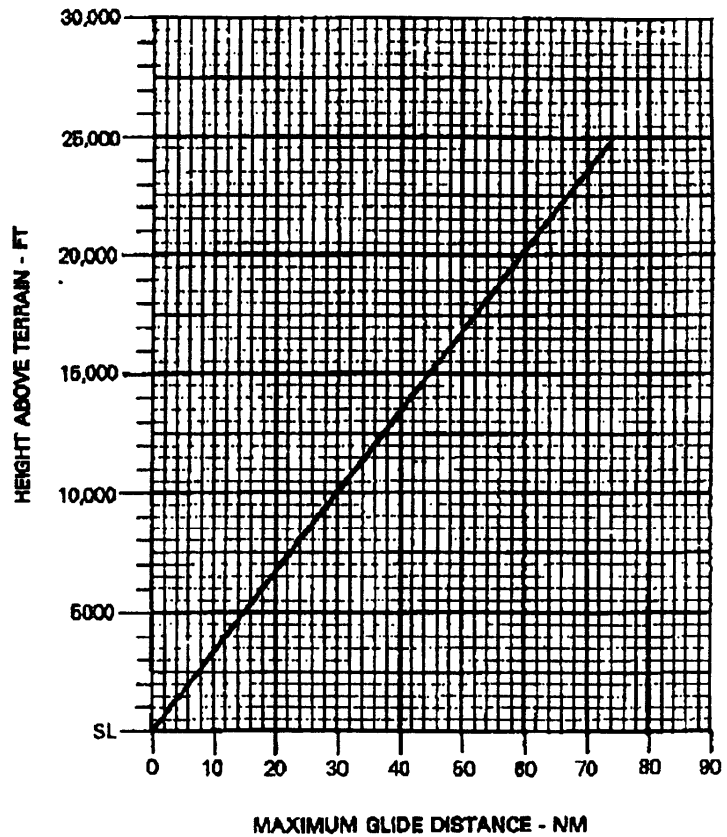

DATA BASIS: ESTIMATED

FIGURE 51. Maximum glide distance (FW)

MIL-PRF-63029J

### AUTOROTATIONAL GLIDE CHARACTERISTICS POWER OFF

**EXAMPLE**

**WANTED**

GLIDE RATIO AND RATE OF DESCENT

**KNOWN**

AIRSPEED — 80 KIAS ROOF  
 ROTOR RPM — 314

**METHOD**

ENTER INDICATED AIRSPEED  
 MOVE UP TO 314 ROTOR RPM LINE  
 MOVE LEFT, READ GLIDE RATIO — 4.5  
 CONTINUE UP 80 KIAS TO 314 ROTOR  
 RPM LINE ON UPPER GRAPH. MOVE  
 LEFT, READ RATE OF DESCENT — 1725  
 FPM

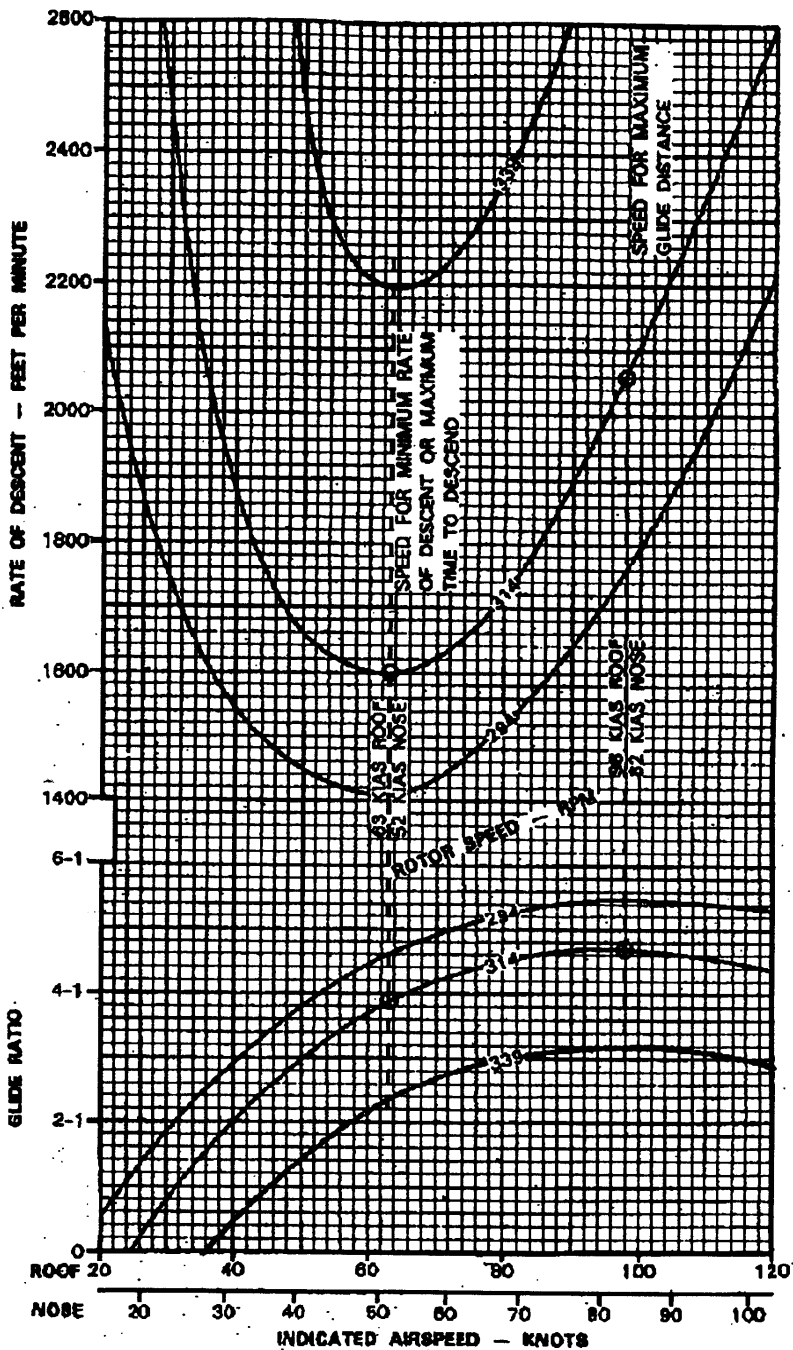

DATA BASIS: CALCULATED DATA

FIGURE 52. Autorotational descent

MIL-PRF-63029J

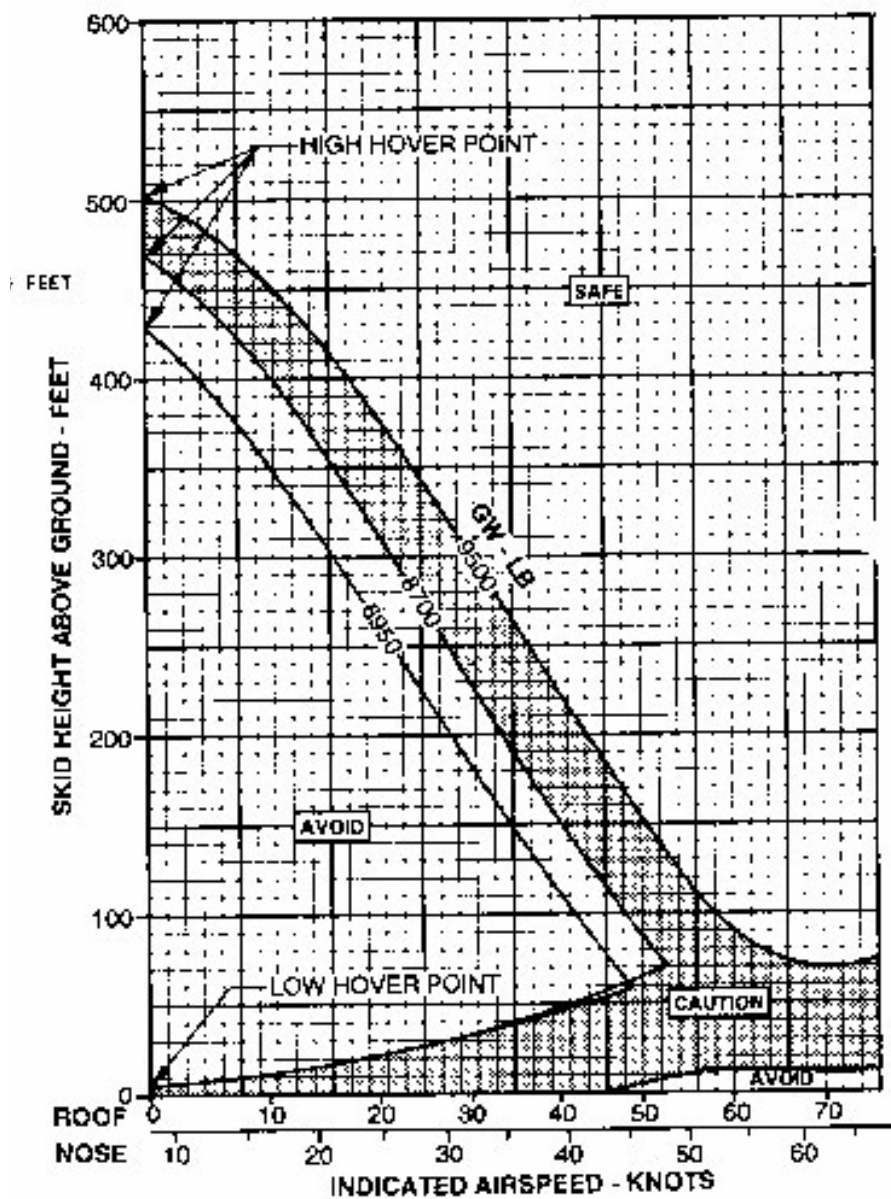

DATA BASIS: DERIVED FROM FLIGHT TEST FTC-TDR 57.27 NOVEMBER 1964

FIGURE 53. High velocity diagram

MIL-PRF-63029J

TM X-XXXX-XX-10

By Order of the Secretary of the Army:

Official:

JANE DOE  
*General, United States Army*  
*Chief of Staff*

JOHN DOE  
*Administrative Assistant to the*  
*Secretary of the Army*  
0000000

DISTRIBUTION:

To be distributed in accordance with Initial Distribution Number (IDN) XXXXXX, requirements for TM X-XXXX-XXX-10

**FIGURE 54. Example of authentication page**

MIL-PRF-63029J

***These are the instructions for sending an electronic 2028***

The following format must be used if submitting an electronic 2028. The subject line must be exactly the same and all fields must be included; however only the following fields are mandatory: 1, 3, 4, 5, 6, 7, 8, 9, 10, 13, 15, 16, 17, and 27.

From: "Whomever" whomever@wherever.army.mil  
To: 2028@redstone.army.mil  
Subject: DA Form 2028

1. **From:** Joe Smith
2. **Unit:** Home
3. **Address:** 4300 Park
4. **City:** Hometown
5. **St:** MO
6. **Zip:** 12345
7. **Date Sent:** 17-OCT-05
8. **Pub No:** 55-2840-229-23
9. **Pub Title:** TM
10. **Publication Date:** 04-JUL-01
11. **Change Number:** 7
12. **Submitter Rank:** MSG
13. **Submitter FName:** Joe
14. **Submitter MName:** T
15. **Submitter LName:** Smith
16. **Submitter Phone:** 123-123-1234
17. **Problem:** 1
18. **Page:** 2
19. **Paragraph:** 3
20. **Line:** 4
21. **NSN:** 5
22. **Reference:** 6
23. **Figure:** 7
24. **Table:** 8
25. **Item:** 9
26. **Total:** 123
27. **Text:**

This is the text for the problem below line 27

**FIGURE 55. Instructions for sending an electronic DA Form 2028**

MIL-PRF-63029J

<b>RECOMMENDED CHANGES TO PUBLICATIONS AND BLANK FORMS</b> <small>For use of this form, see AIR 25-32, the proponent agency is ODI904.</small>						Use Part II (reverse) for Repair Parts and Special Tool Lists (RPSTL) and Supply Catalogs/Supply Manuals (SCSM)	DATE
TO: (Forward to proponent of publication or form)(Include ZIP Code)						FROM: (Activity and location)(Include ZIP Code)	
PART 1 - ALL PUBLICATIONS (EXCEPT RPSTL AND SC/SM) AND BLANK FORMS							
PUBLICATION/FORM NUMBER						DATE	TITLE
ITEM NO.	PAGE NO.	PARA-GRAPH	LINE NO. *	FIGURE NO.	TABLE NO.	RECOMMENDED CHANGES AND REASON	
<small>* Reference to line numbers within the paragraph or subparagraph.</small>							
TYPED NAME, GRADE OR TITLE						TELEPHONE EXCHANGE/AUTOVON, PLUS EXTENSION	SIGNATURE

DA FORM 2028, FEB 74

REPLACES DA FORM 2028, 1 DEC 68, WHICH WILL BE USED.

USAPA V3.01

**FIGURE 56. Sample DA Form 2028**



MIL-PRF-63029J

# **TM 1-1550-695-CL**

---

## **TECHNICAL MANUAL OPERATOR'S AND CREWMEMBER'S CHECKLIST**

**RAVEN  
(RQ-11B)  
(EIC: N/A)  
(NSN 1550-01-538-9256)**

**DISTRIBUTION STATEMENT D:** Distribution authorized to DoD and DoD contractors only. This determination was made on 9 December 2005. Other requests must be referred to UAV Project Office (SFAE-AV-UAVS).

**DESTRUCTION NOTICE** - Destroy by any method that will prevent disclosure of contents or reconstruction of the document. Destroy by any method to prevent enemy use.

---

**HEADQUARTERS  
DEPARTMENT OF THE ARMY  
9 December 2005**

**FIGURE 57. Operator's and crewmember's checklist cover/title page**

MIL-PRF-63029J

TM 1-1550-695-CL

CHANGE HEADQUARTERS  
NO. 1 DEPARTMENT OF THE ARMY  
WASHINGTON, D.C., 30 May 2007

**TECHNICAL MANUAL  
OPERATOR'S AND  
CREWMEMBER'S CHECKLIST**

**RAVEN  
(RQ-11B)  
(EIC: N/A)  
(NSN 1550-01-538-9256)**

DISTRIBUTION STATEMENT D: Distribution authorized to DoD and DoD contractors only. This determination was made on 9 December 2005. Other requests must be referred to UAV Project Office (SFAE-AV-UAVS).

DESTRUCTION NOTICE - Destroy by any method that will prevent disclosure of contents or reconstruction of the document. Destroy by any method to prevent enemy use.

TM 1-1550-695-CL, 28 March 2005, is changed as follows:

1. Remove and insert pages as indicated below. New or changed text material is indicated by a vertical bar in the margin. An illustration change is indicated by a miniature pointing hand.

Remove pages	Insert pages
N-13 and N-14	N-13 and N-14
E-3 and E-4	E-3 and E-4
-----	E-15 and E-16
P-1 and P-2	P-1 and P-2

2. Retain this sheet in front of manual for reference purposes.

**FIGURE 58. Operator's and crewmember's checklist change transmittal page**

## MIL-PRF-63029J

## TM 9-5895-681-CL

**Publications**

1. TM/Checklist — Verify.

**GCS Power Up**

1. GCS PMCS — Perform.
2. Power Source — Energize.
- ★ 3. I/O Panel CB — Set.
- ④ HMMWV DC CB — On.
- F\* 5. Blackout Override Switch (Lights) — As Required.
6. ECU Mode — Vent.
7. Main CB — On.
- ⑧ CTRL/MON CBs — Engaged.
9. PH REV/AC LIM Lamps — Push to Test/Ext.
10. CTRL/LTS/BAT CBs — Engaged.
- \* 11. UPS 1/UPS 2 LINE CBs — On.
- \* 12. UPS 1/UPS 2 (AVO and MPO) — On.
13. UPS 1/ UPS 2 LOAD CBs — On.
14. **G3** UPS Battery — Check.
- ★ 15. FREQUENCY CHECK  
A-N/B-N/A-B — 60 ±2 Hz.
16. VOLTAGE CHECK

**PGCS Power Up**

- ① PGCS PMCS — Perform.
- ② S1 AC Main Switch — On.
3. Display Power Switch — On.
- ★ 4. Display Green Power LED — Verify.
5. Green SCSI Hard Drive LED — Verify.
- O 6. TACLAN Configuration — Verify/Configure as Required.
- O 7. DII COE — Log In.
8. Security Banner — Verify.
9. VCS Software — As Required.

**Change 2 N-1****FIGURE 59. Example of condensed checklist (normal procedures) page**

MIL-PRF-63029J

**OPERATOR'S AND CREWMEMBER'S  
CHECKLIST**  
OH-58A/C HELICOPTER  
1 April 2003

**DISTRIBUTION STATEMENTS A: Approved for public release;  
distribution is unlimited.**

**This manual supersedes TM 1-1520-228-CL,  
28 July 2000.**

**HELICOPTER AND SYSTEMS  
BEFORE EXTERIOR CHECK**

1. Publications - Check.
2. Covers, locking devices, tie-downs (except main rotor), and grounding cables - Removed and secured.
3. Ignition switch - On.
4. Cockpit - Check.

**EXTERIOR CHECK**

1. Cabin interior - Check.
2. Fuselage (Area 1) - Check.
3. Tailboom (Area 2) - Check, tie-down removed.
4. Main rotor blades (Area 3) - Check, tie-down removed.
5. Tail rotor gear box - Check.
6. Tail rotor - Check.
7. Tailboom (Area 3) - Check.
8. Fuselage (Area 4) - Check.
9. Main rotor blades (Area 4) - Check.
10. Fuselage top - Check.
11. Main rotor system - Check.
12. Fuselage (Area 5) - Check.
13. Cockpit - Check.
14. Fuselage (Area 6) - Check.
15. Crew and passenger briefing - Complete.

**BEFORE STARTING ENGINES**

1. Shoulder harness lock(s) - Check.
2. Overhead switches and circuit breakers - Set.
3. GPU - Connect for GPU - start.
4. Avionics - Off and set.
5. Instrument panel instruments & switches - Check and set.
6. Flight controls - Check and set.
7. Throttle - Check. Move to open, then to idle stop; press idle release and close.

**STARTING ENGINE**

1. Fireguard - Post if available.
2. Rotor Blades - Check clear and untied.
3. Engine - Start.
4. GPU - Disconnect, then BAT switch - BAT, if required.
5. N2 - Stabilized.
6. THROTTLE ADJUST - 70 percent N1.
7. GEN switch - GEN.
8. DC amps - Check 60 or less.
9. INV switch - INV.
10. Avionics - On.

**ENGINE RUNUP**

1. Engine and transmission instruments - Check.
2. Throttle - Slowly increase to open. Set N2 to 100 percent.
3. Flight instruments - Check and set.
4. Doors, armor side panels, and seat belts - Secure.

**BEFORE TAKEOFF**

1. N2 - 100 percent.
2. Systems - Check.
3. Crew, passengers, mission equipment, and seat belts - Check.
4. Avionics - As required.

**HOVER CHECK**

1. Flight controls - Check.
2. Engine and transmission instruments - Check.
3. Flight instruments - Check as required.
4. Power - Check.

**BEFORE LANDING**

1. Crew, passenger, and mission equipment - Check.
2. Landing light - As required.

**ENGINE SHUTDOWN**

1. Throttle - Engine idle; stabilize TOT for two minutes.
2. FORCE TRIM switch - FORCE TRIM.
3. FUEL BOOST switch - OFF.
4. MGVLDG LTS - OFF.
5. Control stations - On.
6. Avionics - On.
7. Overhead switches and circuit breakers - Set.
8. Battery charge - Check.
9. Throttle - Close.
10. Overhead switches - OFF as required.
11. Ignition switch - OFF (keys as required.)

**BEFORE LEAVING THE HELICOPTER**

1. Main rotor blades - Tie down as required.
2. Walk-around - Complete.
3. DA Form 2408-12 and 2408-13-1 - Complete.
4. Secure helicopter - As required.

**THRU-FLIGHT CHECKLIST**

**PREFLIGHT**

1. Covers, locking devices, tie-downs (except main rotor), and grounding cables - Removed and secured.
2. Ignition switch - On.
3. Cargo/loose equipment - Check.
4. Auxiliary fuel cell - Check.
5. Passenger and seat belts - Check.
6. Hydraulic reservoirs/servos and flight controls - Check.
7. Transmission compartment - Check.
8. Fuel - Check quantity.
9. Main rotor blade - Check, tie-down removed.
10. Tail rotor gear box - Check.
11. Tail rotor - Check.

**TM 1-1520-228-CL**

12. Engine Oil Level - Check.

13. Main rotor system - Check condition.

14. Crew and passenger briefing - Complete.

**BEFORE STARTING ENGINE**

1. ANTI COLL LTS switch - As required.
2. POS LTS switch - As required.
3. BAT switch - As required.
4. GPU - Connect for GPU start.
5. Flight control - Check and set.
6. Throttle - Check. Move to open, then to idle stop; press idle release and close.

**STARTING ENGINE**

1. Fireguard - Post if available.
2. Rotor Blades - Check clear and untied.
3. Engine - Start.
4. GPU - Disconnect, then BAT switch - BAT, if required.
5. N2 - Stabilized.
6. THROTTLE ADJUST - 70 percent N1.
7. GEN switch - GEN.
8. DC amps - Check 60 or less.
9. INV switch - INV.
10. Avionics - On.

**ENGINE RUNUP**

1. Engine and transmission instruments - Check.
2. Throttle - Slowly increase to open. Set N2 to 100 percent.
3. Flight instruments - Check and set.
4. Doors, armor side panels, and seat belts - Secure.

**BEFORE TAKEOFF**

1. N2 - 100 percent.
2. Systems - Check.
3. Crew, passengers, mission equipment, and seat belts - Check.
4. Avionics - As required.

By Order of the Secretary of the Army:

Official:  **ERIC K. SHINSEKI**  
General, United States Army  
Chief of Staff

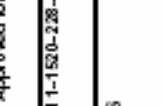
 **JOEL B. HUDSON**  
Administrative Assistant to the  
Secretary of the Army  
0304902

To be distributed in accordance with Initial Distribution Number (IDN) 310239, requirements for TM 1-1520-228-CL

**FIGURE 60. Example of an alternate operator's and crewmember's checklist (sheet 1 of 2)  
(This example has been reduced to fit on the page.)**

MIL-PRF-63029J

TM 1-1520-Z28-CL	
EMERGENCY PROCEEDURES	CLUTCH FAILS TO DISENGAGE 1. <u>Throttle - Close.</u> 2. <u>LAND AS SOON AS POSSIBLE.</u>
ENGINE MALFUNCTION	MAST BUMPING <u>LAND AS SOON AS POSSIBLE.</u>
ENGINE FAILURE - HOVER	FIRE HOT START 1. <u>STABILIZER switch - Press.</u> 2. <u>Throttle - Close.</u>
ENGINE FAILURE - LOW ALTITUDE/LOW AIRSPEED OR CRUISE	ENGINE FUSELAGE/ELECTRICAL FIRE - GROUND <u>EMER SHUTDOWN</u>
ENGINE RESTART - DURING FLIGHT	ENGINE FUSELAGE/FIRE - IN-FLIGHT IF Power - On landing: 1. <u>LAND AS SOON AS POSSIBLE.</u> 2. <u>EMER SHUTDOWN after landing.</u>
ENGINE COMPRESSOR STALL	IF Power - Off landing: 1. <u>AUTOBROUATE.</u> 2. <u>EMER SHUTDOWN.</u> 3. <u>EMER SHUTDOWN after landing.</u>
ENGINE OVERSPEED	ELECTRICAL FIRE - FLIGHT 1. <u>PAT and GEN switches - OFF.</u> 2. <u>LAND AS SOON AS POSSIBLE.</u> 3. <u>EMER SHUTDOWN after landing.</u>
IF RPM cannot be controlled manually:	SMOKE AND FUME ELIMINATION 1. <u>Verify - Onset.</u> 2. <u>RECIRC &amp; VENT SWITCH - ON.</u>
ENGINE UNDERSPEED	ELECTRICAL SYSTEM MALFUNCTIONS GENERATOR FAILURE - NO OUTPUT 1. <u>GEN FIELD and GEN &amp; BUS RESET circuit breakers</u> - Check in.
If powered flight with rotor in the green can be accomplished:	2. <u>GEN switch - RESET, then GEN - Do not hold the switch in the RESET position.</u>
If engine underspeed below 94% N2, then:	IF the generator is not restored, or it goes off the line again: 3. <u>GEN switch - OFF.</u> 4. <u>Turn OFF all unnecessary electrical equipment.</u> 5. <u>LAND AS SOON AS PRACTICABLE.</u>
ENGINE SURGES	OVERHEATED BATTERY 1. <u>PAT switch - OFF.</u> 2. <u>LAND AS SOON AS POSSIBLE.</u> 3. <u>EMER SHUTDOWN after landing.</u>
If surges in engine RPM are experienced:	HYDRAULIC SYSTEM MALFUNCTION HYDRAULIC POWER FAILURE 1. <u>Airspeed - Adjust.</u> 2. <u>HYD BOOST SOL circuit breaker - Out.</u> If hydraulic power is not restored: 3. <u>HYD BOOST SOL circuit breaker - In.</u> 4. <u>HYD BOOST switch - OFF.</u> 5. <u>LAND AS SOON AS PRACTICABLE.</u>
If engine surges are not controlled in steps 1 and 2 above:	LANDING AND DITCHING DITCHING - POWER ON 1. <u>Doors - Jettison at a hover.</u> 2.
ROTOR S, TRANSMISSION, AND DRIVE SYSTEMS MALFUNCTION	LOSS OF TAIL ROTOR EFFECTIVENESS (LTE) 1. <u> pedal - Full left.</u> 2. <u> pedal - Forward.</u> 3. <u>As recovery is effected, adjust controls for normal flight.</u>
MAN DRIVESHAFT FAILURE	1. <u>AUTOBROUATE - Establish power on autorotational gear.</u> 2. <u>EMER SHUTDOWN after landing.</u>
ROTOR RPM	MASTER CAUTION
ENGINE OUT	ENGINE OIL PRESS (Red)
XMSN OIL PRESS (Red)	XMSN OIL HOT (Red)
<b>WARNING LIGHT</b>	
ROTOR RPM	Verify condition. Adjust collective.
MASTER CAUTION	Check for Caution Panel segment light illumination. If none, <u>LAND AS SOON AS POSSIBLE.</u>
ENGINE OUT	Verify condition. <u>AUTOBROUATE.</u>
XMSN OIL PRESS (Red)	<u>LAND AS SOON AS POSSIBLE.</u>
XMSN OIL HOT (Red)	<u>LAND AS SOON AS POSSIBLE.</u>
<b>CAUTION PANEL LIGHTS</b>	
<b>CAUTION LIGHT</b>	
FUEL BOOST	<u>LAND AS SOON AS PRACTICABLE.</u>
20 mh fuel	<u>LAND AS SOON AS PRACTICABLE.</u>
FUEL FILTER	<u>LAND AS SOON AS POSSIBLE.</u>
ENG OIL BYPASS	<u>LAND AS SOON AS POSSIBLE.</u>
ENG CHIP DET	<u>LAND AS SOON AS POSSIBLE.</u>
XMSN CHIP DET	<u>LAND AS SOON AS POSSIBLE.</u>
TR CHIP DET	<u>LAND AS SOON AS POSSIBLE.</u>
INST INVERTER	Information/system status.
DC GENERATOR	Refer to emergency procedures.
HYD PRESS	Refer to emergency procedures.
IFF	Information/system status.
SPARE	<u>LAND AS SOON AS POSSIBLE.</u>
<b>FLIGHT CONTROL MALFUNCTIONS</b>	
1. <u>LAND AS SOON AS POSSIBLE.</u>	
2. <u>EMER SHUTDOWN after landing.</u>	
<b>LIGHTNING STRIKE</b>	
<u>LAND AS SOON AS POSSIBLE.</u>	
<b>IN-FLIGHT WIRE STRIKE</b>	
<u>LAND AS SOON AS POSSIBLE.</u>	
<b>WARNING PANEL LIGHTS</b>	
<b>DITCHING - POWER OFF</b>	
1. <u>AUTOBROUATE.</u>	
2. <u>Doors - Jettison.</u>	
3. <u>Crew and passengers - Exit when the main rotor stops.</u>	
4. <u>AUTOBROUATE.</u>	
5. <u>Pilot - Exit when the main rotor stops.</u>	
2. <u>Crew (except pilot) and passengers - Exit.</u>	
3. <u>Hover at a safe distance away from personnel.</u>	
4. <u>AUTOBROUATE.</u>	

FIGURE 60. Example of an alternate operator's and crewmember's checklist (sheet 2 of 2)  
(This example has been reduced to show bleed-borders.)

MIL-PRF-63029J

---

**\* TM 1-1520-238-MTF**

---

**TECHNICAL MANUAL**

**MAINTENANCE TEST**

**FLIGHT MANUAL**

**FOR**

**ARMY APACHE  
HELICOPTER**

**AH-64D  
(EIC:RHA)**

**WARNING** - This document contains technical data whose export is restricted by the Arms Export Control Act (Title 22, U.S.C., Sec 2751, et. seq.) or the Export Administration Act of 1979, as amended, Title 50, U.S.C., App. 2401 et. seq. Violations of these export laws are subject to severe criminal penalties. Disseminate in accordance with provisions of DoD Directive 5230.25.

**DISTRIBUTION STATEMENT D:** Distribution authorized to the DOD and DOD contractors only due to Critical Technology effective as of 15 June 2003. Other requests must be referred to Commander, US Army Aviation and Missile Command, ATTN: SFAE-AV-UH/L, Redstone Arsenal, AL 35898-5230.

**DESTRUCTION NOTICE** - Destroy by any method that will prevent disclosure of contents or reconstruction of the document.

\* This manual supersedes TM 1-1520-238-MTF, dated 31 March 1997, including all changes.

---

**HEADQUARTERS DEPARTMENT  
OF THE ARMY  
1 May 2003**

**FIGURE 61. Example of MTF cover**

MIL-PRF-63029J

TM 1-1520-238-MTF

CHANGE HEADQUARTERS  
 No. 3 DEPARTMENT OF THE ARMY  
 WASHINGTON, D.C., 30 April 2005

**TECHNICAL MANUAL**  
**MAINTENANCE TEST**  
**FLIGHT MANUAL**  
**FOR**  
**ARMY APACHE HELICOPTER**  
**AH-64D**  
**(EIC:RHA)**

**DISTRIBUTION STATEMENT D:** Distribution authorized to the DOD and DOD contractors only due to Critical Technology effective as of 15 June 2003. Other requests must be referred to Commander, US Army Aviation and Missile Command, ATTN: SFAE-AV-AH, Redstone Arsenal, AL 35898-5230.

TM 1-1520-238-MTF, dated 1 May 2003, is changed as follows:

1. Remove and insert pages as indicated below. On a changed page, the portion of the text affected by the latest change is indicated by a vertical line in the outer margin of the page. Changes to illustrations are indicated by a hand pointing to the changed area on the illustration or a MAJOR CHANGE symbol.

<b>Remove Pages</b>	<b>Insert Pages</b>
A and B	A and B
i through iv	i through iv
2-11 and 2-12	2-11 and 2-12
2-29 and 2-30	2-29 and 2-30
2-45 and 2-46	2-45 and 2-46
2-63 and 2-64	2-63 and 2-64
-----	2-64.1/(2-64.2 Blank)

2. Retain this sheet in front of manual for reference purposes.

**FIGURE 62. Example of an MTF change transmittal page**

MIL-PRF-63029J

TM 1-1520-238-MTF

**REPORTING ERRORS AND RECOMMENDING  
IMPROVEMENTS**

You can help improve this manual. If you find any mistakes, or if you know of a way to improve the procedures, please let us know. Mail your letter, DA Form 2028 (Recommended Changes to Publications and Blank Forms) located in the back of the applicable operator's manual, (ensure the publication number and title reflect this MTF) direct to: Commander, U.S. Army Aviation and Missile Command, ATTN: AMSAM-MMC-MA-NP, Redstone Arsenal, AL 35898-5000. A reply will be furnished to you. You may also send in your comments electronically to our e-mail address: 2028@redstone.army.mil or by fax 256-842-6546/DSN 788-6546. Instructions for sending an electronic 2028 may be found at the back of the Aircraft Operator's manual.

**ENVIRONMENTAL/HAZARDOUS  
MATERIAL INFORMATION**

This document has been reviewed for the presence of Class 1 Ozone Depleting Chemicals. As of 17 March 1995, the status is: All references to Class 1 Ozone Depleting Chemicals have been removed from this document by substitution with chemicals that do not cause atmospheric ozone depletion.

**TABLE OF CONTENTS**

	<b>Page</b>
I Introduction .....	1-1
II Maintenance Test Flight Checklist .....	2-1
Prior to Maintenance Test Flight .....	2-1
Interior Check– Pilot .....	2-1

i

**FIGURE 63. Example of MTF title page w/table of contents**



## MIL-PRF-63029J

UH-60A MAINTENANCE TEST FLIGHT CHECK SHEET SUGGESTED FORMAT				
A/C NO.	PURPOSE OF TEST			DATE
PILOT AND UNIT				TIME
GROSS WEIGHT LB	CG	FAT°C	PRESS ALT	DENSITY ALT
SYMBOLS      ✓ = SATISFACTORY      X = DEFICIENCY				
<b>PRIOR TO MTF</b>		d. Trim system		
1. Forms and records		(1) Cyclic force		
2. Flight readiness inspection		(a) Aft cyclic force    lb.		
3. Special preflight checks		(b) Right cyclic force    lb.		
<b>BEFORE STARTING ENGINE</b>		(2) Beep time rate		
1. Fuel pump		(a) Aft to fwd    sec		
2. APU start		(b) Left to right    sec		
3. Caution/Advisory panel		e. Collective to yaw coupling		
4. CDU/PDU/TRQ		f. FPS heading hold		
5. Stabilator audio priority		10. Stabilator		
6. Flight control hydraulic system		11. Fuel quantity		
a. Forward cyclic stop    inch		12. Altimeter (BARO)    ft		
7. Collective friction    LB		13. Altimeter (RADAR)		
8. Tail rotor servo		14. Fire detector		
9. AFCS check		15. Windshield anti-ice		
a. SAS /FPS computer check		16. Pitot heater		
b. SAS engage-disengage error		17. Blade deice test		
c. Flight control breakout force		18. Fuel boost pumps		
(1) Pitch Fwd    oz. AFT    oz.		19. Start abort&heater dropout		
(2) Roll Left    oz. RT    oz.		<b>STARTING ENGINES</b>		
(3) Yaw Fwd    lb. AFT    lb.		1. No. 1 engine start		
<b>REMARKS:</b>				

FIGURE 64. Example of MTF check sheet (reduced in size)

MIL-PRF-63029J

TM 1-1520-238-MTF

**SECTION IV. SPECIAL/DETAILED  
PROCEDURES**

**GENERAL.** This section contains special/detailed procedures that were referenced in Section Section II.

**A. NVG SYSTEMS - CHECK.**

N 1. NVG check if use is anticipated.

- a. **MA WRN** and **CAUT ADVSY NVG DIMMING** control — Full clockwise position.
- b. **INSTR LT PILOT FLT** — Turn control clockwise from **OFF**.
- c. Caution/Advisory **BRT/DIM TEST** switch — **BRT/ DIM** momentarily; then **TEST** and hold.
- d. All caution/advisory/master warning panels at reduced light level.
- e. Pilot's and copilot's **VSI/HSI MODE SEL** legends, **CIS MODE SEL**, panel legends, pilot's and copilot's VSI legends, and **AFCS FAILURE ADVISORY** lights illuminate.
- f. While still holding caution/advisory **TEST** switch, press and release **PNL LTS** button on copilot's cyclic stick — All caution/advisory panel legends extinguish.
- g. Press and release pilot's **PNL LTS** button. Caution/ Advisory legends reilluminate. Release caution/ advisory panel switch.
- h. Rotate **CAUT ADVSY NVG DIMMING** control on instrument panel to **DIM**. Caution/Advisory panel legends decrease in brightness.
- i. Rotate **MA WRN NVG DIMMING** control on instrument panel to **DIM**. Master warnings decrease in brightness.

4-1

**FIGURE 65. Example of MTF special/detailed procedures page**

MIL-PRF-63029J

**TM 1-XXXX-XXX-MTF**

TM 1-1520-238-MTF

**SPECIFICATION TORQUE  
AVAILABLE - 10 MINUTE LIMIT**

HIRSS INSTALLED      100% RPM R  
TGT 866 ±9            120 KTAS

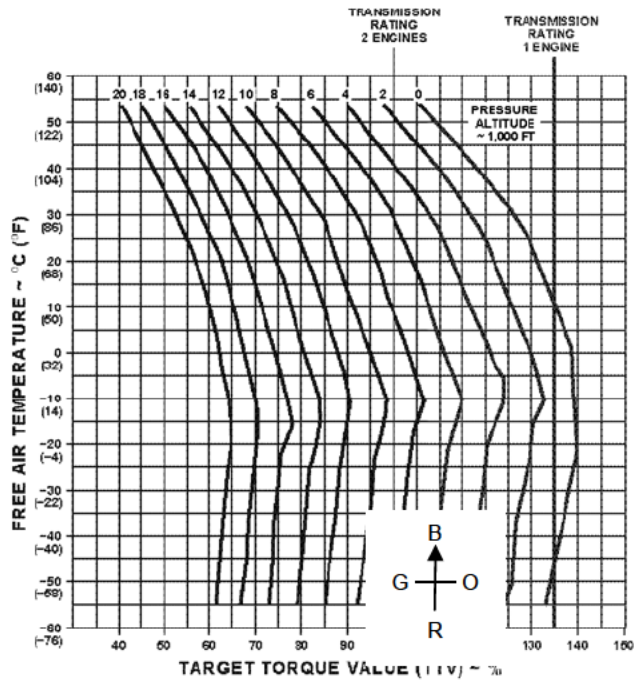

AA7281B\_CL  
SA

Figure 5-11. Determining Target Torque Value (TTV)

**701C**

5-17

**FIGURE 66. Example of MTF chart**

MIL-PRF-63029J

**TM 1-XXXX-XXX-MTF****The Metric System and Equivalents****Linear Measure**

1 centimeter = 10 millimeters = .39 inch  
 1 decimeter = 10 centimeters = 3.94 inches  
 1 meter = 10 decimeters = 39.37 inches  
 1 dekameter = 10 meters = 32.8 feet  
 1 hectometer = 10 dekameters = 328.08 feet  
 1 kilometer = 10 hectometers = 3,280.8 feet

**Weights**

1 centigram = 10 milligrams = .15 grain  
 1 decigram = 10 centigrams = 1.54 grains  
 1 gram = 10 decigrams = .035 ounce  
 1 dekagram = 10 grams = .35 ounce  
 1 hectogram = 10 dekagrams = 3.52 ounces  
 1 kilogram = 10 hectograms = 2.2 pounds  
 1 quintal = 100 kilograms = 220.46 pounds  
 1 metric ton = 10 quintals = 1.1 short tons

**Liquid Measure**

1 centiliter = 10 milliliters = .34 fl. ounce  
 1 deciliter = 10 centiliters = 3.38 fl. ounces  
 1 liter = 10 deciliters = 38.82 fl. ounces  
 1 dekaliter = 10 liters = 2.64 gallons  
 1 hectoliter = 10 dekaliters = 26.42 gallons  
 1 kiloliter = 10 hectoliters = 264.18 gallons

FIGURE 67. Example of metric conversion chart

## MIL-PRF-63029J

## APPENDIX A

**REQUIREMENTS MATRICES**

A.1 Scope. This appendix provides the content requirements for development and presentation of printed page-based Operator's manuals covered by this specification.

A.2 Intended use. First, determine the types of TMs required for each acquisition and then duplicate the table(s) that contains the content requirements for those types of TMs. For each type of TM selected, indicate in the open blocks the "TM" content desired by entering an "R" for "REQUIRED" content or a "P" for content that is "PROHIBITED," or an "AR" for content that is "AS REQUIRED." All blocks for the selected TM types in Table A-I through Table A-III must be completed with an "R," a "P," or an "AR" for each TM acquisition. The blocks that already contain an "R" are required and cannot be changed. The blocks containing "P" are prohibited for that type of TM and shall not be included. The blocks that are shaded are content items where a decision must be made whether they are required to support the equipment. The blocks that are shaded shall be filled in with "R," "P," or "AR." If a decision on a shaded item cannot be made before contract award, mark it with an "AR" for "As Required." When a decision can be made, the "AR" notations shall be changed to a "P" or "R."

## MIL-PRF-63029J

## APPENDIX A

TABLE A-I. Requirements matrix for operator's manual (-10) (Sheet 1 of 7)

TM Content		MIL-PRF-63029 Reference	Element Name
Front Matter	R	3.5.4	<front>
Cover	R	3.5.4.1	<cover>
Warning page		3.5.4.2	<warnsum>
Change transmittal page		3.5.4.3	<chginsst>
List of Effective Pages	R	3.5.4.4	<lep>
Abbreviated Title Page	R	3.5.4.5	<titlepage>
Table of Contents	R	3.5.4.6	<contents>
Chapter 1 – Introduction	R	3.5.5	<chapter1>
Chapter 2 – Aircraft and Systems Description and Operation	R	3.5.6	<chapter2>
Aircraft	R	3.5.6.1	<ch2sect1>
Emergency equipment	R	3.5.6.2	<ch2sect2>
Engines and related systems	R	3.5.6.3	<ch2sect3>
Fuel system	R	3.5.6.4	<ch2sect4>
Flight control system	R	3.5.6.5	<ch2sect5>
Hydraulic and pneumatic systems	R	3.5.6.6	<ch2sect6>
Power Train	R	3.5.6.7	<ch2sect7>
Rotors or propellers	R	3.5.6.8	<ch2sect8>
Utility systems	R	3.5.6.9	<ch2sect9>
Heating, ventilation, cooling, and environmental control systems	R	3.5.6.10	<ch2sect10>
Electrical power supply and distribution system	R	3.5.6.11	<ch2sect11>
Auxiliary power unit	R	3.5.6.12	<ch2sect12>
Lighting	R	3.5.6.13	<ch2sect13>
Flight instruments	R	3.5.6.14	<ch2sect14>
Servicing, parking, and mooring	R	3.5.6.15	<ch2sect15>
Approved primary, alternate, and emergency fuels		3.5.6.15.3	
Additional sections		3.5.6.16	<ch2sect additional>
Chapter 3 - Avionics	R	3.5.7	<chapter3>
General	R	3.5.7.1	<ch3sect1>
Existing standard operational avionics data		3.5.7.2.3	
Communications	R	3.5.7.3	<ch3sect2>
Navigation	R	3.5.7.4	<ch3sect3>
Transponder and radar	R	3.5.7.5	<ch3sect4>
Additional avionics equipment		3.5.7.6	

## MIL-PRF-63029J

## APPENDIX A

TABLE A-I. Requirements matrix for operator's manual (-10) (Sheet 2 of 7)

<b>TM Content</b>		<b>MIL-PRF-63029 Reference</b>	<b>Element Name</b>
Chapter 4 - Mission Equipment	R	3.5.8	<chapter4>
Non-standard mission avionics equipment	R	3.5.8.2	<ch4sect1>
Armament		3.5.3	<ch4sect2>
Cargo handling	R	3.5.4	<ch4sect3>
Passive defense	R	3.5.5	<ch4sect4>
Additional system coverage		3.5.6	<ch4sect additional>
Chapter 5 - Operating Limits and Restrictions	R	3.5.9	<chapter5>
General	R	3.5.9.2	<ch5sect1>
System limits	R	3.5.9.3	<ch5sect2>
Power limits	R	3.5.9.4	<ch5sect3>
Loading limits	R	3.5.9.5	<ch5sect4>
Center of gravity limitations		3.5.9.5.1	
Weight limitations	R	3.5.9.5.2	
Turbulence	R	3.5.9.5.3	
Weight limitations	R	3.5.9.5.1	
Other limitations	R	3.5.9.5.4	
Maximum and minimum airspeed limits	R	3.5.9.6	<ch5sect5>
Airspeed presented using measurement other than knots		3.5.9.6.1	
Maneuvering limits	R	3.5.9.7	<ch5sect6>
Environmental restrictions	R	3.5.9.8	<ch5sect7>
Additional limits or restrictions		3.5.9.9	<ch5sect additional>
Chapter 6 - Weight/Balance and Loading	R	3.5.10	<chapter6>
General	R	3.5.10.1	<ch6sect1>
Aircraft compartment and station diagram	R	3.5.10.1.1	
Weight and balance	R	3.5.10.2	<ch6sect2>
Alternate linear dimension units of measurement		B.3.11	
Fuel/oil	R	3.5.10.3	<ch6sect3>
Oil data		3.5.10.3.1	
Personnel	R	3.5.10.4	<ch6sect4>
Mission equipment	R	3.5.10.5	<ch6sect5>
Cargo loading	R	3.5.10.6	<ch6sect6>
Center-of-gravity	R	3.5.10.7	<ch6sect7>
Lateral center-of-gravity limitations		3.5.10.7	
Additional weight/balance and loading		3.5.10.8	

## MIL-PRF-63029J

## APPENDIX A

TABLE A-I. Requirements matrix for operator's manual (-10) (Sheet 3 of 7)

TM Content		MIL-PRF-63029 Reference	Element Name
Chapter 7 - Performance Data	R	3.5.11	<chapter7>
Aerodynamic report illustrating the derivation of the data entered on the charts		3.5.11.1	
Section I - Introduction	R	3.5.11.2	<ch7sect1>
Section II and subsequent sections	R	3.5.11.3	<ch7sectDataCharts >
Performance data charts derived from source other than flight test reports		3.5.11.1.1	
Alternate or additional baseline configurations		3.5.11.1.4	
Additional charts for alternate fuel		3.5.11.1.5	
Insertion of standard day, standard conditions, standard temperature or density altitude information		3.5.11.1.6	
Charts to use more than three variables		E.3.2.1	
Alternate order of priorities in charts		E.3.2.2	
Use of four division scale grids for graphical data presentation		E.3.2.5.7	
Minimal minor grid spacing other than as specified		E.3.2.5.7	
Data range is other than as specified		E.3.2.5.9	
Rotary wing performance data (rotary wing systems only)		3.5.11.3.1	
Additional rotary wing performance data		3.5.11.3	
Fuel flow chart	R	3.5.11.3.1.1	
Maximum torque available chart	R	3.5.11.3.1.2	
Hover chart	R	3.5.11.3.1.3	
Critical data chart		3.5.11.3.1.4	
Takeoff chart	R	3.5.11.3.1.5	
Additional takeoff technique charts		3.5.11.3.1.5	
Drag chart	R	3.5.11.3.1.6	
Alternate configuration drag chart		3.5.11.3.1.6	
Cruise chart	R	3.5.11.3.1.7	
Altitudes and temperatures of cruise chart	R	3.5.11.3.1.7	
Climb-descent chart	R	3.5.11.3.1.8	
Airspeed calibration chart		3.5.11.3.1.9	
Optimum cruise chart		3.5.11.3.1.10	



## MIL-PRF-63029J

## APPENDIX A

TABLE A-I. Requirements matrix for operator's manual (-10) (Sheet 4 of 7)

TM Content		MIL-PRF-63029 Reference	Element Name
Fixed wing performance data (fixed wing systems only)	R	3.5.11.3.2	
Additional fixed wing performance data		3.5.11.3	
Crosswinds – takeoff and landing chart	R	3.5.11.3.2.1	
Idle fuel flow chart	R	3.5.11.3.2.2	
Torque available for takeoff chart	R	3.5.11.3.2.3	
Takeoff chart	R	3.5.11.3.2.4	
Rotation/takeoff airspeed chart	R	3.5.11.3.2.5	
Flap settings/other applicable information provided and explained		3.5.11.3.2.5	
Acceleration check distance chart	R	3.5.11.3.2.6	
Accelerate-stop distance chart	R	3.5.11.3.2.7	
Accelerate after lift off chart	R	3.5.11.3.2.8	
Minimum single engine control airspeed chart (flaps down and up, if applicable)	R	3.5.11.3.2.9	
Single engine climb chart	R	3.5.11.3.2.10	
Cruise climb chart	R	3.5.11.3.2.11	
Drag chart	R	3.5.11.3.2.12	
Cruise chart	R	3.5.11.3.2.13	
Specific altitudes, configurations and temperatures for charts		3.5.11.3.2.13	
Single engine and multi-engine data on one chart		3.5.11.3.2.13	
Climb/descent chart	R	3.5.11.3.2.14	
Approach speed chart	R	3.5.11.3.2.15	
Separate chart for each configuration		3.5.11.3.2.15	
Landing chart	R	3.5.11.3.2.16	
Landing chart valid for other stores configurations other than specified		3.5.11.3.2.16	
Airspeed calibration chart	R	3.5.11.3.2.17	
Omission of airspeed, altitude, and calibration data		3.5.11.3.2.17	
Optimum cruise chart		3.5.11.3.2.18	
Chapter 8 - Normal Procedures	R	3.5.12	<chapter8>
Crew duties	R	3.5.12.2	<ch8sect1>
Operating procedures and maneuvers	R	3.5.12.3	<ch8sect2>
Addition or removal of specific checks		3.5.12.3.28	
Instrument flight	R	3.5.12.4	<ch8sect3>

## MIL-PRF-63029J

## APPENDIX A

**TABLE A-I. Requirements matrix for operator's manual (-10) (Sheet 5 of 7)**

<b>TM Content</b>		<b>MIL-PRF-63029 Reference</b>	<b>Element Name</b>
Flight characteristics	R	3.5.12.5	<ch8sect4>
Adverse environmental conditions	R	3.5.12.6	<ch8sect5>
Cold weather operations	R	3.5.12.6.1	
Preparation for flight	R	3.5.12.6.2	
Engine starting	R	3.5.12.6.3	
Warm-up and ground testing	R	3.5.12.6.4	
Taxiing and hovering instructions	R	3.5.12.6.5	
Before takeoff	R	3.5.12.6.6	
Takeoff	R	3.5.12.6.7	
During flight	R	3.5.12.6.8	
Descent	R	3.5.12.6.9	
Landing	R	3.5.12.6.10	
Engine shutdown	R	3.5.12.6.11	
Desert and hot weather operations	R	3.5.12.6.12	
Turbulence and thunderstorm operations	R	3.5.12.6.13	
Rain	R	3.5.12.6.14	
Additional sections		3.5.12.6.15	<ch8sect additional>
Chapter 9 - Emergency Procedures	R	3.5.13	<chapter9>
Aircraft systems	R	3.5.13.2	<ch9sect1>
Emergency equipment and exits	R	3.5.13.2.1	
Engine	R	3.5.13.2.2	
Flight characteristics under partial power conditions	R	3.5.13.2.2.1	
Engine malfunction under specific conditions	R	3.5.13.2.2.2	
Engine malfunction during takeoff and low altitude/low airspeed flight	R	3.5.13.2.2.3	
Engine malfunction during cruise	R	3.5.13.2.2.4	
Engine malfunction during final approach	R	3.5.13.2.2.5	
Engine restart during flight	R	3.5.13.2.2.6	
Maximum glide	R	3.5.13.2.2.7	
Autorotational descent	R	3.5.13.2.2.8	
Landing with one or more engines inoperative	R	3.5.13.2.2.9	
Go-around with one or more engines inoperative (fixed wing)	R	3.5.13.2.2.10	

## MIL-PRF-63029J

## APPENDIX A

TABLE A-I. Requirements matrix for operator's manual (-10) (Sheet 6 of 7)

TM Content		MIL-PRF-63029 Reference	Element Name
Height velocity	R	3.5.13.2.2.11	
Base of plots determined by acquiring activity		3.5.13.2.2.11	
Require time delay period before initiation of collective pitch control motion following a loss of power		3.5.13.2.2.11	
Propeller/ rotor, transmissions, and drive systems	R	3.5.13.2.3	
Propeller failure	R	3.5.13.2.3.1	
Tail rotor failure and directional control malfunctions	R	3.5.13.2.3.2	
Malfunctions of main rotor transmission and drive systems	R	3.5.13.2.3.3	
Other emergencies		3.5.13.2.3.4	
Fire	R	3.5.13.2.4	
Engine fire	R	3.5.13.2.4.1	
Fuselage fire	R	3.5.13.2.4.2	
Wing fire	R	3.5.13.2.4.3	
Electrical fire	R	3.5.13.2.4.4	
Smoke and fume elimination	R	3.5.13.2.4.5	
Fuel system	R	3.5.13.2.5	
Electrical system	R	3.5.13.2.6	
Hydraulic system	R	3.5.13.2.7	
Landing and ditching	R	3.5.13.2.8	
Emergency descent	R	3.5.13.2.8.1	
Landing emergencies	R	3.5.13.2.8.2	
Body positions	R	3.5.13.2.8.3	
Ditching	R	3.5.13.2.8.4	
Flight controls	R	3.5.13.2.9	
Bailout/eject	R	3.5.13.2.10	
Mission equipment	R	3.5.13.3	<ch9sect2>
Emergency jettisoning	R	3.5.13.3.1	
References	R	3.5.14	<references>
Abbreviations and Terms	R	3.5.15	<abbreviations>
Appendices		3.5.16	<appendix>
Index		3.5.17	<index>
Authentication Page	R	3.5.18	<authent>
DA Form 2028	R	3.5.19	<da2028>

## MIL-PRF-63029J

## APPENDIX A

**TABLE A-I. Requirements matrix for operator's manual (-10) (Sheet 7 of 7)**

<b>TM Content</b>		<b>MIL-PRF-63029 Reference</b>	<b>Element Name</b>
Metric Conversion Chart	R	3.5.20	<metric>
Foldouts		3.5.21	<foldsect>

## MIL-PRF-63029J

## APPENDIX A

TABLE A-II. Requirements matrix for operator's checklist (-CL)

TM Content		MIL-PRF-63029 Reference	Element Name
Use of warnings, cautions and notes in explanatory material		3.6.1	
Cover	R	3.6.2.1	<cover>
Notices	R	3.6.2.2	<notices>
Change transmittal page		3.6.2.3	<chginsst>
General information and scope	R	3.6.2.4	<geninfo>
Normal procedures	R	3.6.2.5	<normal>
List of crewmembers' duties		3.6.2.5	
Through-flight checklist		3.6.2.6	<thruflight>
Emergency procedures	R	3.6.2.7	<emergency>
List of crewmembers' duties		3.6.2.7	
Performance data		3.6.2.8	<perfddata>
Detailed performance checks		3.6.2.8.2	<check>
Performance data charts		3.6.2.8.1	<figure>
Authentication Page	R	3.6.2.10	<authent>
Foldouts		3.6.2.11	<foldsect>
Alternate operator's checklist		3.6.3	<alternatecl>
Front matter	R	3.6.3.1	<alternatefront>
Notices	R	3.6.3.1.1	<notices>
General information and scope	R	3.6.3.2	<geninfo>
Normal procedures	R	3.6.3.3	<normal>
Emergency procedures	R	3.6.3.4	<emergency>

## MIL-PRF-63029J

## APPENDIX A

**TABLE A-III. Requirements matrix for maintenance test flight manual (-MTF)**

<b>TM Content</b>		<b>MIL-PRF-63029 Reference</b>	<b>Element Name</b>
Cover	R	3.7.2.1	<cover>
Warning page	R	3.7.2.2	<warnsum>
Change transmittal page	R	3.7.2.3	<chginsst>
Abbreviated title page	R	3.7.2.4	<titlepage>
Table of contents	R	3.7.2.4	<contents>
Section I. Introduction	R	3.7.3	<mtf-intro>
Section II. Maintenance test flight checklist	R	3.7.4	<checklist>
Omission or addition of checklist items		3.7.4.1	
Section III. Troubleshooting guides	R	3.7.5	<troubleshoot>
Section IV. Special/detailed procedures		3.7.6	<specialprocs>
Section V. Charts and forms	R	3.7.7	<chartsforms>
Required chart list and format by acquiring activity	R	3.7.7.1	
List of charts	R	3.7.7.2	<ListOfCharts>
Additional sections		3.7.1	
Appendices		3.7.7.4	<appendix>
DA 2028 Forms			<da2028>
Authentication Page	R	3.7.7.5	<authent>
Metric Conversion Chart	R	3.7.7.6	<metric>
Foldouts		3.7.7.7	<foldsect>

## MIL-PRF-63029J

## APPENDIX B

**STYLE AND FORMAT REQUIREMENTS FOR OPERATOR'S MANUAL**

B.1 Scope. This appendix provides the style and format requirements for development and presentation of printed page-based Operator's manuals covered by this specification.

B.2 Applicable documents.

B.2.1 General. The documents listed in this section are specified in section B.3 of this specification. This section does not include documents cited in other sections of this specification or recommended for additional information or as examples. While every effort has been made to ensure the completeness of this list, document users are cautioned that they must meet all specified requirements documents cited in section B.3 of this specification, whether or not they are listed.

B.2.2 Government documents.

B.2.2.1 Specifications, standards, and handbooks. The following specifications, standards, and handbooks form a part of this document to the extent specified herein. Unless otherwise specified, the issues of these documents are those cited in the solicitation or contract.

## DEPARTMENT OF DEFENSE STANDARD

MIL-STD-40051-2

Preparation of Digital Technical Information for  
Page-Based Technical Manuals

AR 25-52

Authorized Abbreviations, Brevity Codes, and Acronyms

(Application for copies of DoD documents should be addressed to the Standardization Document Order Desk, 700 Robbins Avenue, Building 4D, Philadelphia, PA 19111-5094 or at <https://assist.daps.dla.mil/>.)

B.2.3 Order of precedence. In the event of a conflict between the text of this document and the references cited herein, the text of this document takes precedence. Nothing in this document however, supersedes applicable laws and regulations unless a specific exemption has been obtained.

## MIL-PRF-63029J

## APPENDIX B

B.3 Style and format.

B.3.1 Front matter arrangement. Unless otherwise specified (6.2), front matter preceding the first chapter of a TM shall consist of the following in the order specified:

- a. Cover.
- b. Warning page.
- c. Change transmittal page.
- d. List of effective pages.
- e. Abbreviated title page/table of contents.

B.3.1.1 Cover. A cover shall be provided. Type sizes for the cover shall be such that all the information can be included within the prescribed area. Refer to Table B-I for applicable type styles and sizes.

B.3.1.2 Warning page. The warning page shall begin on the first right-hand page immediately following the cover. The page(s) shall be numbered with lower case letters.

B.3.1.3 Change transmittal page. When applicable, the change transmittal page (s) shall follow the warning page. The change transmittal pages(s) shall not have page numbers.

B.3.1.4 List of effective pages. The list of effective pages shall be numbered with an upper case letter centered on the bottom of the page.

B.3.1.5 Abbreviated title page/table of contents. Space permitting, the abbreviated title page information and the table of contents shall be placed on the same page. If the title page information fills up most of the page, the table of contents may begin on the first right-hand page following the abbreviated title page. The abbreviated title page/table of contents shall be assigned sequential lower case Roman numerals, i.e., i, ii, iii, etc.

B.3.2 Size. Operator's TMs shall be prepared for a final trim size of 8-½ inches wide by 11 inches in length. The usable area for preparation of the manuals shall be 7-¼ by 10 inches (including marginal copy).

B.3.3 Structure. The contents of the Operator's manual shall be structured as follows:

- a. Chapters – divides TM into major divisions.
- b. Sections – divides chapters into specific areas of coverage.



## MIL-PRF-63029J

## APPENDIX B

- c. Sub-sections – divides sections into applicable areas of coverage
- d. Paragraph and subparagraphs – divide sections into specific topics.

B.3.3.1 Chapter and section requirements. As applicable, each chapter shall start on an odd numbered page. One or more sections may be contained in a chapter. More than one section may be on one right- or left-hand page, provided there is a minimum amount of space remaining for a heading and one entire line of text to start the next section.

B.3.3.2 Page arrangement. All text shall be arranged in a double column page. Each column shall be approximately 3/8 inches wide with a gutter approximately 1/4 inch wide between the columns. Text shall be arranged in a 7 by 10 inch image area.

B.3.4 Text formatting. All text within the Operator's manual shall be formatted as instructed below. (See Table B-I for font formatting.)

B.3.4.1 Primary paragraphs <para0>. (See Figure B-1) Primary paragraphs shall divide text within chapters or sections.

B.3.4.1.1 Primary paragraph sideheads <title>. There shall be at least one primary paragraph sidehead in each chapter or section. Primary paragraph sideheads shall begin at the left margin. They shall be followed by a period and two spaces and are stand alone (are not run in with text) See Table B-I for vertical spacing.

B.3.4.1.2 Primary Paragraph numbers. Primary paragraphs shall be numbered. All primary paragraph numbers shall be preceded by the chapter number and a hyphen, e.g. the first primary paragraph of Chapter 1 would be 1-1, the second primary paragraph would be 1-2, etc.

B.3.4.2 Subordinate paragraphs. (See Figure B-1)

B.3.4.2.1 Subordinate paragraph sideheads <title>. Subordinate paragraphs should, but are not required to, have a sidehead. If a subordinate paragraph has a side head, it shall be followed by a period. The first letter of the first word and each principal word shall be capitalized. The paragraph text may begin on the same line separated by two spaces following the period. See Table B-I for vertical spacing.

B.3.4.2.2 Subordinate paragraph indenture. The first line of each new level subordinate paragraph shall be indented approximately an additional 0.2 inches with the remaining lines wrapping back to the left margin.

B.3.4.2.3 Subordinate paragraph numbers. Subordinate paragraphs shall be numbered.

B.3.4.2.3.1 First level subordinate paragraphs <subpara1>. The first level subordinate paragraph shall be numbered consecutively in lower case letters followed by a period and two spaces.

## MIL-PRF-63029J

## APPENDIX B

B.3.4.2.3.2 Second level subordinate paragraphs <subpara2>. The second level subordinate paragraph shall be numbered consecutively in Arabic numbers within parenthesis followed by two spaces.

B.3.4.2.3.3. Third level subordinate paragraphs <subpara3>. The third level subordinate paragraph shall be numbered consecutively in lower case letters within parenthesis followed by two spaces.

B.3.4.2.3.4 Fourth level subordinate paragraphs <subpara4>. The fourth level subordinate paragraph shall be numbered consecutively in underlined Arabic numbers followed by a period and two spaces.

B.3.4.3 Procedural steps <step1> through <step5>. Procedural steps shall begin two lines below the preceding text, and indented approximately five spaces from the left margin (Figure B-1). Substeps (<step2> through <step5>) shall be indented approximately an additional three spaces from the parent step. The text for all steps shall begin on the same line as the step number and be separated by two spaces. Carry over lines shall not return to the left margin but shall start under the first letter of the preceding line.

B.3.4.3.1 First level step numbering. The first level procedural steps shall be numbered consecutively in Arabic numbers followed by a period and two spaces.

B.3.4.3.2 Second level step numbering. The second level procedural steps shall be numbered consecutively in lower case letters followed by a period and two spaces.

B.3.4.3.3 Third level step numbering. The third level procedural steps shall be numbered consecutively in Arabic numbers within parenthesis followed by two spaces.

B.3.4.3.4 Fourth level step numbering. The fourth level procedural steps shall be numbered consecutively in lower case letters within parenthesis followed by two spaces.

B.3.4.3.5 Fifth level step numbering. The fifth level procedural steps shall be numbered consecutively in underlined Arabic numbers followed by a period and two spaces.

B.3.5 TM identification number. Unless otherwise specified by the acquiring activity (6.2), the publication number shall be the same as the TM number of the aircraft system, followed by "-10" for operator's manuals. The TM number shall appear on the cover right justified in the top margin and on all other pages centered in the top margin in boldfaced type.

B.3.6 Joint manuals. When Operator's manuals are acquired by one Service for joint use with another Service, each Service's number shall be prefixed with the word "Army", "Navy (NAVSEA) (NAVAIR)", "Marine Corps", or "Air Force", as applicable. The acquiring activity's TM number shall be placed above the using activity's TM identification number. Paragraphs in joint publications which do not apply to all Services concerned shall be marked to indicate the Services to which they do apply.

## MIL-PRF-63029J

## APPENDIX B

B.3.7 Publication date. The publication date shall be specified by the acquiring activity (6.2), and shall be the date at which the last material to be included was received. The date shall be written in the sequence: day; month; year, for example 23 JUNE 1996.

B.3.8 Page numbers. Except for foldout pages, page numbers shall be located at the lower center of the page and shall be in boldfaced type. Even numbers, including zero, shall be assigned to left-hand pages and odd numbers to right-hand pages. Manuals divided into chapters shall contain consecutively numbered pages, tables and illustrations for the entire chapter. Page, table, and illustration numbers shall consist of the chapter number, followed by a hyphen, and then a second number representing the order within the chapter. The change indicator shall be displayed in line with the page number and at the outside edge of the page with the word "Change" followed by the change designator for that page.

B.3.9 Text. The text shall be written in clear, simple, and concise language. Technical terms requiring special knowledge shall be avoided, except where no other wording shall convey the intended meaning. Procedures shall be broken down into distinct steps for accomplishment. All procedures called out shall be fully explained in logical completion sequence. Classified information shall not be included in any TMs.

B.3.10 Abbreviations and acronyms. The first use of abbreviations and acronyms shall have the word(s) spelled out completely with the abbreviation or acronym in parentheses immediately after the word(s). Acronyms such as PMCS shall be in all capital letters and shall contain no spaces or periods but abbreviations such as U.S., etc, e.g., etc may contain periods. Acronyms used in figures and tables shall be spelled out in a footnote to the applicable figure or table.

- a. Acronyms, abbreviations, and unusual terms may be used in any text, when applicable.
- b. Abbreviations and acronyms, which are accepted as words (radar, sonar, laser, etc.) need not be included.
- c. All abbreviations and acronyms used in the manual, including those in tables or figures, shall be defined in the "list of abbreviations/acronyms" section of the manual.
- d. Use of abbreviations and acronyms shall follow the following criteria:
  1. DoD unique abbreviations and acronyms shall be taken from JP 1.02.
  2. Army abbreviations and acronyms shall be taken from <https://www.rmda.army.mil/abbreviation>.
  3. Any new abbreviations and acronyms shall be developed in accordance with AR 25-52.
  4. When abbreviations or acronyms are used as markings on the equipment (placarding), the same abbreviations or acronyms shall be used in the TM.

## MIL-PRF-63029J

## APPENDIX B

B.3.11 Dimensional data. Except for weight and balance values in Chapter 6 of an Operator's manual, linear dimensions shall be stated in feet and inches or in inches and decimal fractions, unless otherwise specified by the acquiring activity (6.2). No more than 3 decimal places shall be used. When dimensions are less than a foot, they shall be expressed in inches and decimal fractions. All dimensions, tolerances, clearances, measurements, and decimal equivalents appearing in Chapters 8 and 9 of an Operator's manual shall be stated in bold capital lettering in the text and on illustrations.

B.3.12 Nomenclature. The nomenclature of items shall be the short name used in the applicable aircraft parts manuals, TM 1-XXXX-XXX-23P. The only exception shall be the use of placard item names shown on controls, switches, panels, etc. These items shall be expressed as shown on the placards. These items shall appear in text and procedural steps in boldfaced capital letters.

B.3.13 Warnings, cautions, and notes use and placement.

a. A warning identifies and highlights an essential operating or maintenance procedure, practice, condition, statement, etc., which, if not strictly observed, could result in injury to, death of, or long-term health hazards to personnel. A caution identifies and highlights an essential operating or maintenance procedure, practice, condition, statement, etc., which, if not strictly observed, could result in damage to or destruction of equipment, or loss of or degraded mission effectiveness. A note identifies and highlights an essential procedure, condition, or statement. All warnings, cautions, and notes shall immediately precede the procedure/step to which they apply. Order of appearance shall be first warnings, then cautions, and lastly notes.

b. The header WARNING, CAUTION, or NOTE shall be bold and centered above the appropriate text. Headers shall not be numbered. When a warning, caution, or note consists of two or more paragraphs, the header WARNING, CAUTION, or NOTE shall not be repeated above each paragraph. Warnings, cautions, and notes on unrelated topics that pertain to the same procedural step(s) may be grouped under one heading. However, they shall be all warnings, or all cautions or all notes. They shall not be mixed.

c. When grouping warnings, cautions, or notes each warning, caution or note shall be separated by at least one line and may be bulleted.

d. Layout shall not result in warnings, cautions, and notes divided so first lines of text or groups of icons appear on one page and remaining lines or groups of icons on another.

e. Layout shall avoid warnings, cautions, and notes being placed on a different page than the paragraph to which they apply.

f. Warnings for hazardous materials/conditions shall include guidance pertaining to exposure (i.e., first aid treatment).

## MIL-PRF-63029J

## APPENDIX B

B.3.14 Appendixes. Appendixes shall immediately follow the last chapter of the TM and shall begin on a right-hand page. The title shall be written with all capitals, for example “APPENDIX A”. Pages, paragraphs, illustrations and tables shall be consecutively numbered in Arabic numerals preceded by the capital letter of the appendix, e.g. page A-17 (page) or Figure B-17.

B.3.15 Index. Unless otherwise specified by the acquiring activity (6.2), an alphabetical I index shall be prepared. It shall begin on a right-hand page. It shall list pertinent subjects under every topic for which users are likely to look. “See” and “see also” references may be included to guide the user to other pertinent entries. All applicable paragraph numbers for each item shall be indicated. Page numbers for indexes shall be consecutively numbered in Arabic numerals with the word “Index” preceding the page number. The index shall be located at the end of the publication but shall be located before foldout page(s). Each manual or volume in a set of manuals shall contain its own index. Refer to MIL-STD-40051-2 for the preparation requirements for a multi-volume index.

B.3.16 Amplified checklist. The checklist format for Chapter 8, normal procedures (3.5.12) shall be as shown in MIL-PRF-63029, Figure 59. All checklist titles, such as “BEFORE EXTERIOR CHECK” shall be boldfaced capital type. Checklist entries shall be listed numerically and shall be blocked. Checklist entries shall have the first letters of each line of type aligned. Placarded items shall be in boldfaced capital letters. Paragraphs shall have type returned to the left margin.

B.3.17 Emergency procedure pages. Emergency procedure pages (Chapter 9) of the operator’s manual that contain emergency procedure information/steps shall have heavy black diagonal lines around three edges (Figure B-2).

B.3.18 Designator symbols. Designator symbols such as **B** shall be used in conjunction with text headings, text contents, and illustrations to show limited applicability of the material. If more than one model is described or the aircraft has a variety of configurations, one or more symbols may follow a text heading or illustration title to highlight that part of the text that pertains to the aircraft or systems in question. If the material applies to all series and configurations, no designator symbols shall be used. Where practicable, descriptive information shall be condensed and combined for all series to avoid duplication. A table showing designator symbols shall be included.

B.3.19 Referencing with a manual in PDF format. When a manual is required to be delivered in a PDF format, references to other descriptive information, maintenance tasks, or other data within the manual shall employ a hotspot to provide a link to the referenced data.

B.3.20 Revisions. When specified by the acquiring activity (6.2), a revision shall be prepared. Revisions shall incorporate current information from previously issued changes to the existing TM. Revisions or changes shall be published at the same frequency as other aircraft system manuals.

a. In a revision, all pages, paragraphs, illustrations, and tables shall be renumbered, as necessary, to eliminate all number suffixes and to establish correct sequences.

MIL-PRF-63029J

APPENDIX B

- b. Revisions shall be prepared to current specifications and standards.
- c. All change indicators and change dates shall be removed from pages.
- d. All partial pages, miniature pointing hands, shading screening, vertical lines in margin and other change symbols shall be eliminated.

B.3.21 Changes. The change package shall conform to the format of the basic TM. Note: Changes shall be prepared for printing on the same size paper as the basic TM. The changes shall also incorporate all advanced change notices and resolution of outstanding deficiencies. Unless otherwise specified by the acquiring activity (6.2), when required, a change record shall be prepared. These pages shall not be numbered.

B.3.22 Type style and spacing. The following type sizes may be plus-or-minus one point. Slight variations in spacing and leading are permitted. Final reproducible copy shall use below type sizes. The values in the leading column represent the number of points to be added to the current font size for spacing between lines.

## MIL-PRF-63029J

## APPENDIX B

**Table B-I. Standard and alternate operators –  
type style and spacing requirements (Sheet 1 of 4)**

<b>Use</b>	<b>BOOK</b>	<b>Preferred Font Type/Size</b>	<b>Capitalization</b>	<b>Leading (pts)</b>	<b>Vertical Spacing</b>
Cover: Security Classification	-10, -CL, -MTF	Sans Serif Bold 14	Upper Case		
Cover TM No.	-CL, -MTF	Sans Serif Bold 18 Centered	Upper Case		36 Points from Top of Page
	-10	Sans Serif Bold 18 Right Justified	Upper Case		36 Points from Top of Page
Cover: Type of Publication	-10, -CL, -MTF	Sans Serif Bold 14 Centered	Upper Case		
Cover: Nomenclature of Equipment	-10, -CL, -MTF	Sans Serif Bold 20 Centered	Upper Case		
Cover: Availability, Supersession Notice	-10, -CL, -MTF	Sans Serif Bold 10 Justified			
Cover: Distribution Statement, Disclosure Notice, Export Control Notice	-10, -CL, -MTF	Distribution A – Sans Serif Bold 10 Centered  All others – Sans Serif Bold 8 Justified			
Cover: Pubdate, Servnomen	-10	Sans Serif Bold 16 Centered	Upper Case		36 Points from Bottom of Page
	-CL, -MTF	Sans Serif Bold 14 Centered	Upper Case		36 Points from Bottom of Page
Pubdate	Alternate -CL	Sans Serif Bold 8	Upper Case		
Title Block Page	-10, -CL, -MTF	Sans Serif 10	Upper and Lower Case		
TM Number	-10, -CL, -MTF	Sans Serif Bold 10 Centered	Upper Case		36 Points from Top of Page
Page No.	-10, -CL, -MTF	Sans Serif Bold 10 Centered			36 Points from Bottom of Page
Change No.	-10, -CL, -MTF	Sans Serif Bold 10 Centered	Upper and Lower Case		36 Points from Bottom of Page
Security Classification	-10, -CL, -MTF	Sans Serif Bold 14	Upper Case		36 Points from Top and Bottom of Page

## MIL-PRF-63029J

## APPENDIX B

**Table B-I. Standard and alternate operators –  
type style and spacing requirements (Sheet 2 of 4)**

<b>Use</b>	<b>BOOK</b>	<b>Preferred Font Type/Size</b>	<b>Capitalization</b>	<b>Leading (pts)</b>	<b>Vertical Spacing</b>
Deleted Page Notation	-10, -CL, - MTF	Serif Bold 8	Upper and Lower Case	2	36 Points from Top or Bottom of Page
Chapter No. and Title	-10	Sans Serif Bold 14	Upper Case	6	48 Points Below TM Identification No.; 18 Points Above Text, Table or Illustration
Section No. and Title	-10, -CL, MTF	Sans Serif Bold 14 Centered	Upper Case	6	28 Points Below TM Identification No. or Text of Previous Section; 24 Points Below Chapter Title; 18 Points Above Text, Table or Illustration
Headings: Table of Contents, Safety Summary, Index, Glossary and Appendix		Sans Serif Bold 14	Upper Case		
Troubleshooting Guide heading	-MTF	Sans Serif Bold 10	Upper Case		12 Points Above/Below Text
Troubleshooting Condition and Probable Cause heading	-MTF	Sans Serif Bold 10	Upper and Lower Case		
Text	-10, -CL, - MTF	Sans Serif 10	Upper and Lower Case	2	18 Points Below TM Identification No. or Chapter/Section Title; 12 Points Above/Below Table or Illustration; 6 Points Above Page No.; 12 Points Above/Below Warning Caution and Note Headings
Formulas and Equations	-10, -CL, - MTF	Math 10	Upper and Lower Case	2	12 Points Above/Below Text, Table or Illustration
Primary Sideheads	-10	Sans Serif Bold 10	Upper Case	2	18 Points Below TM Identification No. or Chapter/Section Title; 12 Points Above/Below Text, Table or Illustration; 12 Points Above/Below Warning, Caution and Note Headings



## MIL-PRF-63029J

## APPENDIX B

**Table B-I. Standard and alternate operators –  
type style and spacing requirements (Sheet 3 of 4)**

<b>Use</b>	<b>BOOK</b>	<b>Preferred Font Type/Size</b>	<b>Capitalization</b>	<b>Leading</b>	<b>Vertical Spacing</b>
	-CL, -MTF	Sans Serif Bold 12	Upper Case	2	18 Points Below TM Identification No. or Chapter/Section Title; 12 Points Above/Below Text, Table or Illustration; 12 Points Above/Below Warning, Caution and Note Headings
Subordinate Sideheads	-10	Sans Serif 10	Upper case for First Letter of each Principal Word	2	18 Points Below TM Identification No. or Chapter/Section Title; 12 Points Below Table or Illustration; 12 Points Below Warning, Caution and Note Headings
	-CL, -MTF	Sans Serif Bold 12	Upper case for First Letter of each Principal Word	2	18 Points Below TM Identification No. or Chapter/Section Title; 12 Points Below Table or Illustration; 12 Points Below Warning, Caution and Note Headings
Check title	-CL, -MTF	Sans Serif Bold 12	Upper case		
Subcheck+ title	-CL, -MTF	Sans Serif Bold 10	Upper case for First Letter of each Principal Word		
Figure No. and Title	-10, -CL, -MTF	Sans Serif Bold 10	Upper case for First Letter of each Principal Word	2	18 Points Below Illustration; 6 Points Above Page Number
Legend Text	-10, -CL, -MTF	Sans Serif 8	Upper Case for First Letter of First Word	1	28 Points Above Illustration
Legend on Artwork	-10, -CL, -MTF	Sans Serif 8	Upper Case	1	As Required
Table No. and Title	-10, -CL, -MTF	Sans Serif Bold 10	Upper Case for First Letter of Each Principal Word	2	18 Points Above Table; 18 Points Below TM Identification No.
Table Text	-10, -CL, -MTF	Sans Serif 10	Upper and Lower Case	2	
Rules	-10, -CL, -MTF	.75 Point Width			
Footnotes	-10, -CL, -MTF	Sans Serif 8	Upper and Lower Case	1	18 Points Below Text or Table

## MIL-PRF-63029J

## APPENDIX B

**Table B-I. Standard and alternate operators –  
type style and spacing requirements (Sheet 4 of 4)**

<b>Use</b>	<b>BOOK</b>	<b>Preferred Font Type/Size</b>	<b>Capitalization</b>	<b>Leading (pts)</b>	<b>Vertical Spacing</b>
Warning and Caution Headings	-10, -CL, -MTF	Sans Serif Extra Bold 10 (Boxed)	Upper Case		12 Points Above and Below Text
Note Headings	-10, -CL, -MTF	Sans Serif Extra Bold 10	Upper Case		12 Points Above and Below Text
Maintenance Parts List, Numerical Index and Reference Designation Index Column Heads	-10, -CL, -MTF	Sans Serif 8	Upper Case	1	
Maintenance Parts List Text	-10, -CL, -MTF	Sans Serif 8 or 10	Upper and Lower case	1	
Numerical Index and Reference Designation Index Text	-10, -CL, -MTF	Sans Serif 8	Upper and Lower Case	1	12 Points Space after Every Tenth Entry

## MIL-PRF-63029J

## APPENDIX B

TM 1-1520-123-10

## 8-12. Interior Check.

## a. Subpara1 Subordinate Sidehead

## (1) Subpara2 Subordinate Sidehead

## (a) Subpara3 Subordinate Sidehead

1 Subpara4 Subordinate Sidehead

## 8-13. Forward Cabin.

1. Flight control closet — Check actuators for extended jam buttons and thrust idler assemblies for bent cracked arms, pay particular attention to the area around the rigging pin hole. Check connecting link for cracks or displaced bearings.
- 2. Crew Chief Seat — Check condition and security.
3. Seats, litters, first aid kits, cargo and jettisonable cabin windows — Check condition and security.
4. Utility hatch door and lower rescue door — Check condition and position as required.
- 5. Radar Altimeter — Check condition, knob OFF, Dimming control OFF.

**WARNING**

Ensure roller is fully seated in locked position and hook is fully seated in cam lock or hook will release under loaded conditions.

**CAUTION**

When performing a combat mission or over-water mission, aviator worn gear can restrict head and torso movement. Users should conduct ground familiarity drills (blind switch/control identification) and crew coordination exercises before flight, since field of regard can be restricted by aviator worn mission equipment. The user must strictly adhere to proper crew coordination procedures during switch identification.

6. Center hook — Check condition and position as required. Check psi charge, manual release mechanisms stowed, manual release mechanism for proper cam position and latched.
7. Forward, center and aft manual hook release lever — Check for security and stowed.
8. **ABC** Cable unit — Check Condition.
- 9. Control boxes — Check condition and security.
- 10. Tank installed — Check the following:

- a. All fuel manifold lines, electrical lines, grounding cables, and vent lines to ensure that they are properly secured and connected.

## (1) CONTROL PANEL — Check or set as follows:

- (a) Electrical Receptacles to Fuel Control Panel — Check connection security.
- (b) Electrical Panel to Tank Assembly — Check connection security.
- (c) Wiring Harness — Check connection security.
  1. PANEL illumination switch — OFF.
  2. FUEL switch — Set to 1, 2, 3, and TOTAL to check fuel quantity in each tank (Aircraft power must be on to illuminate).

- b. Fuel manifold lines and tiedown straps for chafing. Tank tiedown straps for security.
- c. Ensure tanks are properly fueled.
- d. Check tanks for leakage.

## ○★ 11. Tank assembly installed — For each installed tank assembly check the following:

Restraint Assembly — Check location and security.

- a. Drain — Check connection and security of drain in use. Check drain not in use capped.
- b. Grounding Cable — Check connection security.

- (c) Vent Hose Assembly — Check connection security. Ensure dust cover is secure on retention strap and connection to dust cap stowage connector.

- (d) Fuel Transfer Hose Assembly — Check connection security; all Unisex valves OPEN.

**CAUTION**

Failure to close the unisex valves at the end of the single point pressure refueling hose assembly could allow suctioning of fuel from the main fuel tanks during operations.

- e. Hose Assembly — Check connection security; unisex valve at Tank CLOSE.
- f. Electrical Harness — Check connection security.

8-5

Change 1

FIGURE B-1. Example of text format (Reduced to fit on page)

## MIL-PRF-63029J

## APPENDIX B

## CHAPTER 9 EMERGENCY PROCEDURES

### SECTION I. AIRCRAFT SYSTEMS

#### 9-1. SAME SAMPLES AS IN NORMAL PROCEDURES

The step creation works the same as in Normal Procedures but the emergency borders will appear on the 11x17 pages.

#### 9-2. EXAMPLE OF STEPS WITH DASHES (PARA — RESPONSE) AND STEPS WITH PARAS.

They are interchangeable.

1. Collective — Adjust to maintain within limits.
2. A step with just a para.
3. POWER lever — LOCKOUT and then retard.
4. LAND AS SOON AS PRACTICABLE.

#### 9-3. ANOTHER EXAMPLE WITH WARNING AND CAUTION.

##### WARNING

Pilot situational awareness is critical in the successful accomplishment of these procedures. The low inertia rotor system, coupled with high rates of descent during vertical autorotation, may not provide the pilot with adequate reaction time and cushioning pitch.

##### CAUTION

If engine chop is used to minimize main rotor torque, increasing collective pitch without first retarding POWER levers to IDLE may cause engine acceleration and uncommanded yaw.

1. Collective — Adjust to maintain within limits.

2. POWER lever — LOCKOUT and then retard.

3. LAND AS SOON AS PRACTICABLE.

#### 9-4. CONDITIONNEW — Numbering restarts with conditionnew

All Armament Wing Stores

1. Airspeed — 100 KTAS Maximum
2. JETT button — Press.

#### 9-5. CONDITIONCONT — Numbering continues from previous condition.

Forward Armament Wing Stores

1. Airspeed — 100 KTAS Maximum
2. Selected STORES JETTISON buttons — Press to go.
3. JETT button — Press.

Aft Armament Wing Stores

4. Airspeed — 100 KTAS Maximum
5. JETT button — Press.

#### 9-6. STEPS WITH PREFIXES (USE THE ATTRIBUTES ON <STEP>)

The attributes have the symbol to be displayed followed by what it represents — hopefully to make it easier to create.

- F\* 1. A step with the flight engineer set to 1 and through-flights set to 1.
- ② A step with the co-pilot responsible set to 1 requires the label to be entered. The help guide on the website provides a pdf of what the codes are used for the label to output the number or letter inside a circle.

9-1/(9-2 blank)

**FIGURE B-2. Example of emergency procedures page**  
(Reduced to fit on page. Actual bleed borders should bleed to 8-½ to 11" edge.)

## MIL-PRF-63029J

## APPENDIX C

**STYLE AND FORMAT REQUIREMENTS FOR OPERATOR'S AND  
-CL CREWMEMBER'S CHECKLISTS**

C.1 Scope. This appendix provides the style and format requirements for development and presentation of printed page-based –CL Operator's checklists and Alternate Operator's checklists.

C.2 Style and format.

C.2.1 Structure. The standard operator's checklist shall be divided into sections: front matter, normal procedures, emergency procedures and performance data. The alternate operator's checklist shall be divided into three sections: front matter, normal procedures and emergency procedures with the front matter and normal procedures on the front page and emergency procedures on the back page.

C.2.2 Front matter arrangement. Unless otherwise specified (6.2), front matter preceding the first chapter of a checklist shall consist of the following in the order specified:

- a. Cover.
- b. Change transmittal page.
- c. General information and scope.

C.2.2.1 Cover. A cover shall be provided. Type sizes are provided in Table B-I.

C.2.2.2 Change transmittal page. When applicable, the change transmittal page(s) (MIL-PRF-63029, Figure 58) shall follow the cover. The change transmittal page(s) shall not have page numbers.

C.2.2.3 General information and scope page(s). The general information and scope pages shall be assigned sequential lower case Roman numerals, i.e., i, ii, iii, etc.

C.2.3 Size. The standard operator's checklist shall be prepared for a final page size of 4-½ inches wide by 8 inches in length with usable area of 3-½ inches wide by 7-½ inches. See Figure C-1. The alternate operator's checklist shall be prepared for a final page size of 11 inches wide by 8-½ inches in length. The usable area for preparation of the alternate operator's checklist shall be 10-1/2 inches wide by 8 inches in length.

C.2.4 Type style. The standard operator's checklist type style, size and spacing shall be in accordance with Table B-I.

C.2.5 Section titles. Heading titles for front matter, normal procedures, emergency procedures and performance data are not required.

## MIL-PRF-63029J

## APPENDIX C

C.2.6 Page numbers. Page numbers in the standard operator's checklist TMs shall consist of a capital letter and an Arabic number separated by a dash. The letter shall correspond to specific parts of the manuals, N for Normal, E for Emergency, P for Performance, and FP for Foldout Pages. Page numbers for standard manual pages shall be centered on the bottom of the page. Pages containing general information and scope shall be numbered with lower case Roman numerals; i, ii, etc. Page numbers in the alternate operators CL shall be numeric.

C.2.7 Primary paragraph sideheads. Primary sideheads shall divide text within sections. There shall be at least one primary sidehead in each section. They shall begin two lines below the preceding paragraph at the left margin and shall not be numbered. They shall be followed by a period and are stand alone (are not run in with text).

C.2.8 Primary paragraph. Primary paragraphs shall begin at the left margin two lines below the primary paragraph sidehead.

C.2.9 Subordinate paragraph sideheads. Subordinate sideheads shall begin two lines below the preceding paragraph at the left margin and shall not be numbered. They shall be followed by a period and two spaces and shall not be numbered. Second and subsequent subordinate paragraphs should, but are not required to, have a sidehead. The first letter of the first word and of each principal word shall be capitalized.

C.2.10 Subordinate paragraphs. Subordinate paragraphs shall have titles (subordinate sideheads). The text may begin on the same line as the subordinate sidehead after a period and two spaces.

C.2.11 Check and subcheck titles. Procedural check and subcheck titles shall begin two lines below the preceding paragraph at the left margin and shall not be numbered. They shall be followed by a period and are stand alone (are not run in with text).

C.2.12 TM identification number. Unless otherwise specified by the acquiring activity (6.2), the publication number shall be the same as the TM number of the aircraft system, followed by "-CL" for operator's checklists. The TM number shall appear centered in the top margin and in boldfaced type.

C.2.13 Change numbers and symbols. For standard operator's checklist TMs, each page (Figure 59) containing changed material shall bear the appropriate change designator (Change 1, Change 2) and shall be located 5 spaces to the right of the page number. Changes to the text, including new material or added pages shall be indicated by a vertical bar in the right margin of odd pages and left margin of even pages extending close to the entire area of the material affected. Change symbols show current changes only.

C.2.14 Revisions. When specified, a revision shall be prepared. Revisions shall incorporate current information from previously issued changes to the existing TM. Revisions or changes shall be published at the same frequency as other aircraft system manuals. For alternate operator's checklist TMs, only revisions shall be prepared, therefore change designators and symbols shall not apply.

## MIL-PRF-63029J

## APPENDIX C

C.2.15 Page arrangement. In the standard checklist, all text shall be prepared in a single column page. The alternate checklist shall be prepared in three columns equally spaced across the 11-inch page which is turned sideways. The alternate checklist shall be printed on card stock and consist of normal procedures on one side and emergency procedures on the opposite side.

For alternate operator's checklist TMs, the following statement shall be added following the date or supersession notice and preceding the text:

“This –CL applies only to the (model number) model of the (aircraft nomenclature), or Use only for the (model number) model of the (aircraft nomenclature).”

C.2.16 Splitting of procedures. For standard operator's checklist TMs, whenever possible, material for in-flight emergency procedures shall be written so that the procedure is contained on a single page. Performance data and procedures such as exterior, interior and before leaving aircraft inspections need not meet this requirement. Each classification of emergency procedures such as engine, propeller/rotor, fire, and fuel should begin on the next right-hand page. For alternate operator's checklist TMs, procedures may be split between columns but shall not be split between a page and the following page.

C.2.17 Fold-out pages. Fold-out pages for textural data shall not be used for operator's checklist TMs. However, for ease of use, graphs included in the checklist may be placed on a foldout page. Foldouts shall be limited to 14" x 8" size pages. Refer to E.3.1.4 for numbering and formatting.

C.2.18 Use of color. Only black print shall be used for operator's checklist TM's.

C.2.19 Definitions of symbols. Symbols used in the checklists shall be the same as those found in 3.5.12.3.2.

C.2.20 Emergency procedures pages. The –CL checklist pages that contain emergency procedure information/steps shall have heavy black diagonal lines around the three unbound edges (Figure C-2). However, for operator's alternate checklists, page borders for emergency procedures shall be placed on all four sides of the page.

MIL-PRF-63029J

APPENDIX C

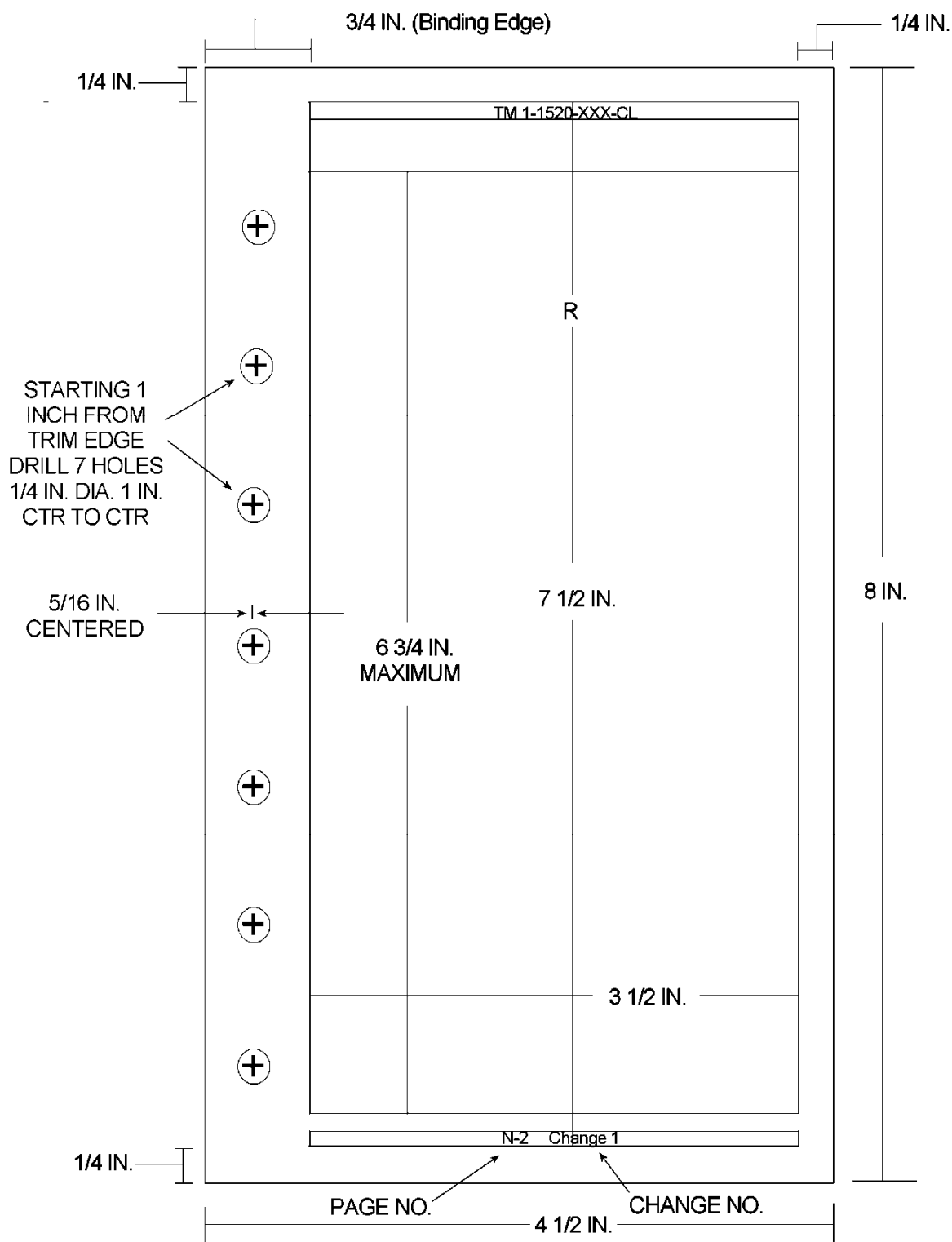

**FIGURE C-1. Page dimensions for condensed checklist and MTF manual**



MIL-PRF-63029J

APPENDIX C

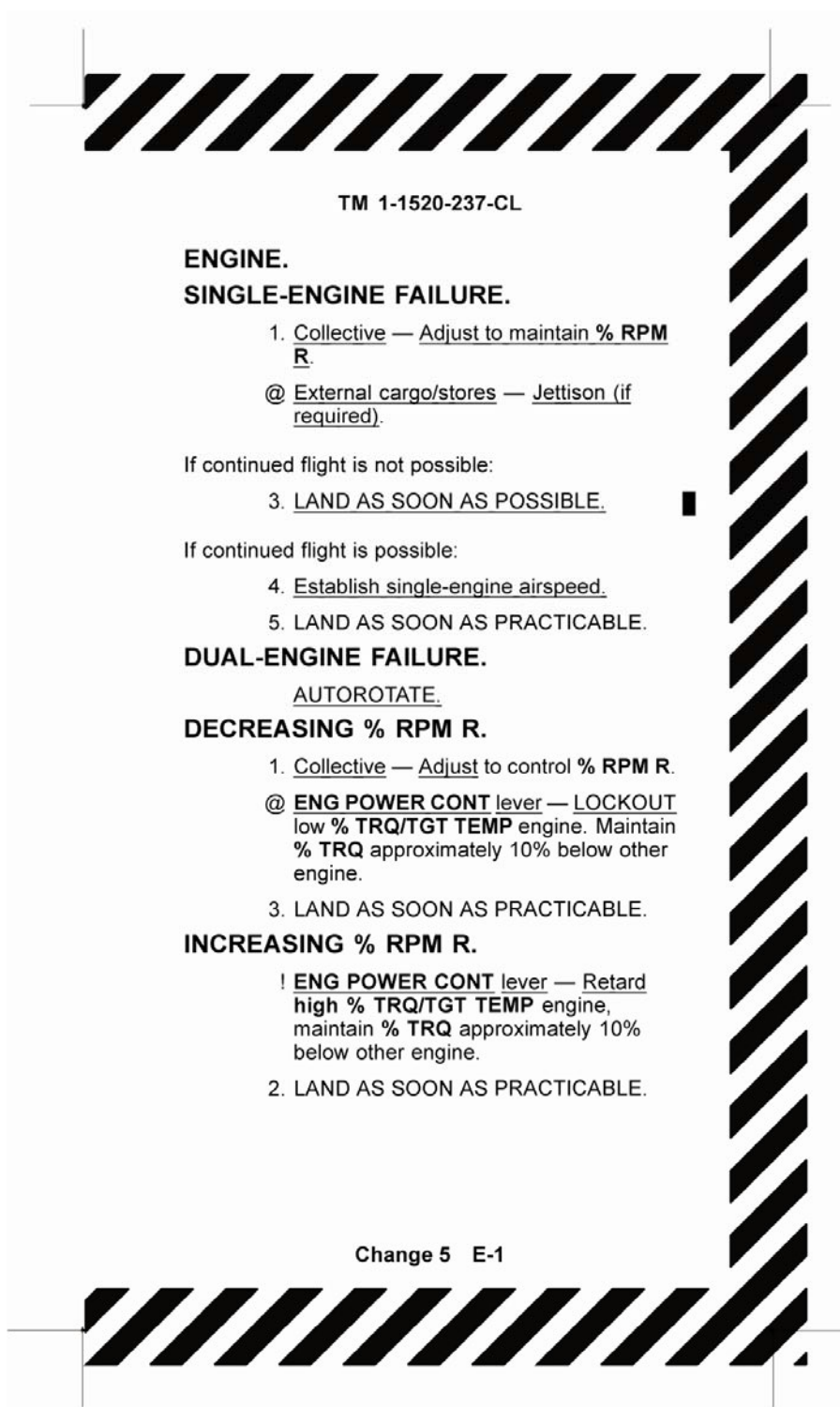

FIGURE C-2. Example of condensed checklist (emergency procedures) page (Image has been reduced.)

## MIL-PRF-63029J

## APPENDIX D

**STYLE AND FORMAT REQUIREMENTS  
FOR  
MAINTENANCE TEST FLIGHT MANUALS**

D.1 Scope. This appendix provides the style and format requirements for development and presentation of printed page-based Maintenance Test Flight manuals (MTFs).

D.2 Style and format.

D.2.1 Structure. The maintenance test flight manual shall be divided into sections; front introduction, maintenance test flight checklist, troubleshooting, specific procedures, charts and forms, and if applicable, appendices, and foldouts.

D.2.2 Front matter arrangement. Unless otherwise specified (6.2), front matter preceding the first chapter of a checklist shall consist of the following in the order specified:

- a. Cover.
- b. Warning page.
- c. Change transmittal page.
- d. Abbreviated title page/table of contents.

D.2.2.1 Cover. A cover shall be provided. Type sizes for the cover shall be such that all the information can be included within the prescribed area.

D.2.2.2 Warning page. The warning page shall begin on the first right-hand page immediately following the cover. The page(s) shall be numbered with lower case letters.

D.2.2.3 Change transmittal page. When applicable, the change transmittal page(s) (Figure 62) shall follow the warning page. The change transmittal page(s) shall not have page numbers.

D.2.2.4 Abbreviated title page/table of contents. Space permitting, the abbreviated title page information and the table of contents shall be placed on the same page. If the title page information fills up most of the page, the table of contents may begin on the page following the abbreviated title page. The abbreviated title page/table of contents shall be assigned sequential lower case Roman numerals, i.e., i, ii, iii, etc.

D.2.3 General Information and scope. The general information and scope pages shall be assigned sequential lower case Roman numerals, i.e., i, ii, iii, etc.

## MIL-PRF-63029J

## APPENDIX D

D.2.4 Size. The standard operator's MTF manual shall be prepared for a final page size of 4-½ inches wide by 8 inches in length with useable area as 3-½ inches wide by 7-½ inches in length. See Figure C-1.

D.2.5 Type style. The standard operator's MTF manual type style, size and spacing shall be in accordance with Table B-I.

D.2.6 Change numbers and symbols. For maintenance test flight manual TMs, each page containing changed material shall bear the appropriate change designator (Change 1, Change 2) and shall be located 5 spaces to the right of the page number. Changes to the text, including new material or added pages shall be indicated by a vertical bar in the left margin extending close to the entire area of the material affected. Change symbols show current changes only.

D.2.7 Revisions. When specified by the acquiring activity (6.2), a revision shall be prepared. Revisions shall incorporate current information from previously issued changes to the existing TM. Revisions or changes shall be published at the same frequency as other aircraft system manuals. For alternate operator's checklist TMs, only revisions shall be prepared, therefore change designators and symbols shall not apply.

D.2.8 Checklist format. All checklist titles shall be left justified and in 10 point boldfaced type (Figure D-1). The main titles shall not be numbered. Checklist entries shall be listed numerically in Arabic numbers in the order they are to be performed and shall be blocked. Checklist entries shall have the first letters of each line of type aligned. Placarded items shall be boldfaced capital letters. If a series of checks continues from a right-hand page to a left-hand page, requiring that the page be turned to continue the procedure, the checklist title shall be repeated at the upper corner of the left-hand or right-hand page followed by "(CONT.)" in bold and upper case.

D.2.8.1 Primary paragraph sideheads. Primary sideheads shall divide text within sections. There shall be at least one primary sidehead in each section. They shall begin two lines below the preceding paragraph at the left margin and shall not be numbered. They shall be followed by a period and are stand alone (are not run in with text).

D.2.8.2 Primary paragraphs. Primary paragraphs shall begin two lines below the Primary paragraph sidehead.

D.2.8.3 Subordinate paragraph sideheads. Subordinate sideheads shall begin two lines below the preceding paragraph at the left margin and shall not be numbered. They shall be followed by a period and two spaces. Second and subsequent subordinate paragraphs should, but are not required to, have a sidehead. The first letter of the first word and of each principal word shall be capitalized.

D.2.8.4 Subordinate paragraphs. Subordinate paragraphs should have titles (subordinate sideheads). The text may begin on the same line as the subordinate sidehead.

## MIL-PRF-63029J

## APPENDIX D

D.2.8.5 Procedural checks and subchecks. Procedural check titles shall begin two lines below the preceding paragraph at the left margin and shall not be numbered. They shall be followed by a period and are stand alone (are not run in with text).

D.2.8.6 TM identification number. Unless otherwise specified by the acquiring activity (6.2), the publication number shall be the same as the TM number of the aircraft system, followed by “-MTF” for MTF manuals. The TM number shall appear centered in the top margin and in boldfaced type.

D.2.8.7 Page numbers. Page numbers in the MTF manual shall consist of a letter and Arabic numerals separated by a dash. The letter shall correspond to specific sections of the manual with the second number(s) corresponding to the page count. Page numbers shall be centered on the bottom of the page. Pages containing the Warning Summary shall be lettered with lower case alphabet; a, b, etc. Pages containing the Table of Contents shall be numbered with lower case Roman numerals; i, ii, etc.

D.2.9 Troubleshooting guides. The troubleshooting guide section in the MTF manual shall begin on a right-hand page. When provided, each guide shall be numbered with an uppercase letter. Troubleshooting guide titles shall be preceded by “TROUBLESHOOTING GUIDE” and a letter. Conditions shall be bold and shall be numbered with the corresponding troubleshooting guide letter and an Arabic number followed by a period and 2 spaces. Troubleshooting guides shall follow the format shown in Figure D-2.

D.2.10 Foldouts. Fold-out pages for textural data shall not be used for maintenance test flight checklist TMs. However, for ease of use, graphs included in the checklist may be placed on a foldout page following the charts and forms figures. Foldouts shall be limited to 14” x 8” size pages. Refer to E.3.1.4 for numbering and formatting.

MIL-PRF-63029J

## APPENDIX D

TM 1-1520-238-11TF

**TAXI CHECK (CONT.)**

2. Engine/Rotor instruments — Check.
3. Flight instruments — Instrument and symbology check.

**\* \* BEFORE HOVER CHECKS**

1. **TAIL WHEEL** switch — **LOCK**.
2. Wheel brakes — Set as required.
- \* 3. HIT and anti-ice check — If not already accomplished, perform at this time. Refer to Chapter 4, paragraph H.
4. Systems — Check.
  - a. **FUEL** panel switches — Set as required.
  - b. Fuel quantity — Sufficient for flight.
  - c. Engine instruments — Normal indications.
  - d. Caution/warning panels — Proper indications.
5. **MASTER/CPG ARM/SAFE** — As required.
6. Weapons select switches — As required.
7. **51** Active **FLY-TO** or **TGT** — Check. If the DTC overwrites the active fly-to or target, it is necessary to de-select and re-select the active fly-to or target.
8. Avionics — As desired.

**HOVER CHECKS**

- \* \* 1. Initial hover check — Takeoff to a stabilized 5 foot hover. Verify normal controllability and stability, and note apparent c.g. Pylons should articulate properly for existing configuration. Note existing vibration levels and stabilator effect on vibrations through full range of stabilator travel.
- \* 2. Instrument checks — Verify proper function and PPC data correlation.
3. Radar Altimeter Accuracy check — Perform.
- \* 4. Hover maneuvering checks:

2-50

**FIGURE D-1. Example of maintenance test flight checklist page**

## MIL-PRF-63029J

## APPENDIX D

TM 1-1520-238-MTF

**SECTION III. FAULT ISOLATION  
PROCEDURES**

**GENERAL** This section contains troubleshooting information that has been referenced in Section II checklists. This section lists possible conditions, abnormal conditions and indications and probably causes. The information is to be used only as a quick reference and may not be all encompassing.

**TROUBLESHOOTING GUIDE A — STARTING****A1. No starter action.**

1. Circuit breaker out.
2. Battery dead.
3. Battery cable connector not connected.
4. GPU polarity reversed (if used).
5. Starter switch inoperative.
6. Faulty starter relay.
7. Starter failure.
8. Wiring to starter open or shorted.
9. Internal seizing of N1 System.

**A2. No N1 indication, but starter turns.**

1. Faulty N1 tachometer transmitter or instrument.
2. Wiring open or shorted.
3. Starter drive failed.
4. N1 gearbox internal failure.

3-1/(3-2 Blank)

**FIGURE D-2. Example of a troubleshooting guide**

## MIL-PRF-63029J

## APPENDIX E

**STYLE AND FORMAT REQUIREMENTS FOR  
ILLUSTRATIONS AND GRAPHS**

E.1 Scope. This appendix provides illustration and graph style and format requirements for the development and printing of Operator's Manuals, -CL Operator's checklists and Alternate Operator's checklists, and Maintenance Test Flight manuals (MTFs).

E.2 Applicable documents.

E.2.1 General. The documents listed in this appendix are referenced in section E.3 of this specification. This appendix does not include documents cited in other sections of this specification or recommended for additional information or as examples. All attempts were made to provide a complete listing of requirements documents.

E.2.2 Government documents. All attempts were made to provide a complete listing of requirements documents.

E.2.2.1 Specifications, standards, and handbooks. The following specifications, standards, and handbooks form a part of this document to the extent specified herein. Unless otherwise specified, the issues of these documents are those cited in the solicitation or contract.

## DEPARTMENT OF DEFENSE HANDBOOK

MIL-HDBK-310                      Global Climatic Data for Developing Military Products

(Application for copies of DoD documents should be addressed to the Standardization Document Order Desk, 700 Robbins Avenue, Building 4D, Philadelphia, PA 19111-5094 or at <http://quicksearch.dla.mil/>.)

E.2.2.2 Other Government documents, drawings, and publications. The following other Government documents, drawings and publications form a part of this document to the extent specified herein. Unless otherwise specified, the issues are those cited in the solicitation or contract.

AR 25-30                              The Army Publishing Program

DA PAM 25-40                      Army Publishing: Action Officers Guide

(Copies of these publications are available from the U.S. Army Publishing Directorate, Distributions Operations Facility, 1655 Woodston Road, St. Louis, MO 63114-6181.)

E.2.3 Order of precedence. In the event of a conflict between the text of this document and the references cited herein, the text of this document take precedence. Nothing in this document however, supersedes applicable laws and regulations unless a specific exemption has been obtained.

## MIL-PRF-63029J

## APPENDIX E

E.3 Style and format.E.3.1 Illustrations.

E.3.1.1 General. Illustration formats shall be as specified by the acquiring activity in accordance with AR 25-30. Line drawings (black lines on white background) shall be used throughout the TM. Photographic illustrations may be used only when prior approval has been obtained from the acquiring activity (6.2). Illustration, including diagrams and schematics, shall be clear, simple, and complete, and shall contain all necessary callouts to support the text. The number of callouts on a single illustration or a single sheet of a multi-sheet illustration shall be 25 or less. If more than 25 callouts are required, the total number required shall be equally divided between two identical or similar illustrations, (Figure 6). Broadsides (illustrations that have been rotated 90 degrees on the page) shall not be used.

E.3.1.2 Lettering. Lettering and type on original artwork shall be well-defined and large enough to be easily read when the illustration is reproduced at page size. Lettering and type shall be in capital letters. The minimum type size shall be eight points. Spacing of letters and words shall be controlled to insure clear, legible copy.

E.3.1.3 Keys for illustrations. Keys may be included on the illustration. Where keys are too numerous or the explanations too lengthy to fit within the illustration cropped area without crowding, they shall be placed in tabular form immediately below the illustration or on the facing page. These tables shall be considered as a text function.

E.3.1.4 Foldouts. Foldouts shall be kept to a minimum. When foldouts are provided they shall be placed at the end of the manual. Foldouts shall have a blank apron. Foldouts shall be page numbered consecutively starting with FP-1, FP-2, etc. Foldouts shall be identified with figure titles and figure numbers and be consecutively numbered starting with FO-1, FO-2, etc.

E.3.1.5 Index numbers. Index numbers shall start with Arabic numeral 1 and continue consecutively within an illustration. For multisheet illustrations, index numbers shall continue in sequence from one sheet to another.

- a. Index numbers shall be presented in one of the following manners:
  - (1) In clockwise sequence, beginning at 11 o'clock. Refer to MIL-HDBK-1222 for examples of callouts starting at 11 o'clock. This is the preferred method.
  - (2) In the order mentioned in the text.
- b. Within a multisheet illustration, if an item that has already been assigned an index number is used in more than one illustration in that multisheet illustration, it shall retain the same index number.

E.3.2 Graphical data.

E.3.2.1 General requirements. Unless otherwise specified by the acquiring activity (6.2), data that includes more than three variables shall be presented graphically. Data with three variables shall



## MIL-PRF-63029J

## APPENDIX E

be presented graphically if it represents continuous data (for example, torque available as a function of altitude and temperature).

E.3.2.2 Order of precedence. In the event of a conflict between the graphical data presentation requirements in the text of this specification and the sample graphs provided, the text of this specification shall take precedence.

E.3.2.3 Explanatory text. A brief explanation shall be provided for each graphic presentation including, but not limited to, description, purpose, and procedure for use, applicable conditions, and effects of their variations.

E.3.2.4 Priorities. Unless otherwise specified by the acquiring activity (6.2), the following order of priorities shall be followed while preparing graphical presentations:

- a. Minimize the possibility of user mistakes.
- b. Cover the full applicable range of data. Unless data ranges are specified in the illustration requirements of this specification, the maximum probable ranges to be expected in operation shall be used. MIL-HDBK-310 can be used for reference for ranges of climatic data.
- c. Provide adequate accuracy. The graphical presentation shall be readable over all ranges of the data. It shall also duplicate the source data to at least one percent of the applicable range of the parameter (for example, a free air temperature range from  $-60^{\circ}\text{C}$  to  $+50^{\circ}\text{C}$  should be readable to at least  $1^{\circ}\text{C}$ ).
- d. Clarity and ease of use. Each graph shall be designed to directly provide the most commonly used parameters (for example, torque required to hover at known conditions of altitude, temperature, weight, and skid/wheel height). Less often used information, such as maximum temperature to hover at a given weight and altitude, shall be obtainable with additional effort.
- e. Ensure standardization. Standardization tables are provided to ensure standardization of graphic illustrations. Type and spacing requirements are summarized in Figure E-1. Line requirements are summarized in Figure E-2. The tables of standardization shall be used during preparation of basic, changed, or revised illustrations. The requirements in the tables of standardization are applicable to the final product. If graphic presentation is other than final size, adjustments shall be made to ensure that final size graphs meet the stated criteria.
- f. Place the graphs on the minimal number of pages, consistent with the importance of clarity and ease of use.
- g. General appearance, cost, and ease of production shall be given consideration, but only as three of the lesser priorities.

E.3.2.5 Specific requirements for graphical data.

## MIL-PRF-63029J

## APPENDIX E

E.3.2.5.1 Titles. Titles for graphs shall be the most succinct title that adequately indicates the nature of the graphical data.

E.3.2.5.2 Condition heading. The range, parameter name, and units of each condition that apply to the data shall be listed with each condition separated. When abstract conditions (for example, clean configuration forward cg) are used, they shall be described in detail and/or quantified in the accompanying text. Conditions that apply to more than three similar graphs shall be listed only on the first example and shall be referred to on all subsequent graphs in the series. General aircraft or system limits shall not be listed. Any condition known not to affect the data shall not be listed. The effect of variation of each listed condition on the data shall be discussed in the text. If the effect of condition variation is not known and cannot be estimated, it shall be so stated in the text. General conditions (for example, rigging, instrument errors, fuel types, etc.) applicable to all data in a chapter shall be discussed in a paragraph titled "General Conditions" which shall appear near the beginning of the chapter. The information in the "General Conditions" paragraph shall not be repeated on the graphs within the chapter.

E.3.2.5.3 Sub-graphs. For some graphical data, it may be desirable to include separate sub-graphs with data on the same general subject. Titles and conditions different from the main conditions shall be given for the sub-graphs.

E.3.2.5.4 Notes. Notes should not be used on graphs. Notes may be placed on areas adjacent to charts, when absolutely necessary, in order to prevent misuse or misinterpretation of the data. If the note does not fit this condition, it should appear in the text.

E.3.2.5.5 Data basis. Data basis information shall include data type (for example, flight test, estimated, etc.) and each actual data source document used to compute the data presented.

E.3.2.5.6 Examples. An example shall be provided on the graphical data to demonstrate primary use of each type of graph. If there are two equally important uses of the charts, a maximum of two examples may be presented on the graph. Additional examples (text only) of other uses or methods of use of the data, where applicable, shall be included in explanatory text. These examples shall be in the same format as those with the graphical data.

E.3.2.5.6.1 Example text. The example text shall be clear yet succinct. Omit articles, conjunctions; prepositions, etc. Wanted parameter names only shall be used. A maximum of three parameters shall be used. If more wanted parameters are available, use additional examples in the explanatory text to explain them. Use one line each to list known parameters and values. If the known parameter value is obtained from elsewhere in the manual, or the source is not evident, parenthetically (below known parameter line) describe the most probable source, such as (from example 1) or (computed from winds aloft). The method for using the graph shall be described using one line per distinct step. Known values shall not be repeated in the method. If needed or useful intermediate values are obtained using the method, these values shall be stated. The example text shall be located on the left side of the graphical data. If multiple examples are used; each example shall be sequentially numbered using Roman numerals (for example, EXAMPLE I,

## MIL-PRF-63029J

## APPENDIX E

EXAMPLE II, etc.). If a single example is used, it shall be identified by the heading "EXAMPLE."

E.3.2.5.6.2 Example values. Example values shall be chosen to represent reasonably critical conditions. Standard and absolute extreme conditions shall not be used. If restricted or special conditions are shown on the chart, the example values shall be chosen to illustrate their effect. Values shall be chosen to require graphical interpolation on every parameter.

E.3.2.5.7 Scaling. Scale and data line increments shall conform to the rule of 1, 2, 5, or 10 minor divisions per major division, except as noted here. The preferred scale grid shall be five minor divisions per major division along each axis. Ten division grids are undesirable and shall be used only when absolutely necessary. Four division grids shall be used only with the permission of the acquiring activity (6.2). Asymmetrical (4 \* 5) grids are permitted. For highly nonlinear variations approximately equal increments of the dependent variable(s) shall be used. The minimal minor grid spacing shall be six points, unless otherwise specified by the acquiring activity (6.2).

E.3.2.5.8 Units. Each parameter on the graph and its corresponding unit of measure shall be those most commonly used for the subject aircraft. If the parameter is available on an aircraft indicator, the units used on the graph shall be the same as those on the indicator. If the parameter is not on an aircraft indicator, the units used shall be the same as those of the most often used source of the data. In some instances, two nearly equal common units may be in use or a transition may be in progress from an older model to a newer model. When this occurs, the primary unit of measure shall be that associated with the new model. Where practicable, the primary unit shall be used on the primary scale and the unit associated with the older model shall be presented on a (redundant) secondary scale. When scales or data include negative values, + and – prefixes shall be used with all numbers for that parameter. For data values on the graph, brackets shall be used around the prefixes.

E.3.2.5.9 Data range. The data range presented shall cover the full applicable range of data. Scales shall extend to the next major division beyond the extreme or limit value(s) and no further, unless specified by the acquiring activity (6.2).

E.3.2.5.10 Grid. The grid shall correspond to the primary scales. Grids shall be prepared to the graphical line standards (Figure E-2).

E.3.2.5.11 Scales. The scale title shall include the parameter name and units of measure. When used, multipliers shall be included with the units (for example, GROSS WEIGHT – pounds \*1000). Multipliers shall be used only to meet specific illustration requirements in this specification for values with three zeros or more, or when significant improvement in the appearance of the graph would result. Resulting fractional values (for example, GROSS WEIGHT – 1000 pounds = 20.2) shall be avoided. Secondary scales should be located on the opposite side of the grid from the primary scale. Scale numbers shall be used for each major, or every other (most even value) major, scale increment, unless the secondary scale corresponds to markings on an aircraft indicator. In this case, the increment and value labeling shall be the same as those on the indicator.

## MIL-PRF-63029J

## APPENDIX E

E.3.2.5.12 Data line labels and values. Labels for data lines shall include the parameter name, multiplier, if any, units, and corresponding value. They shall be located approximately at the midpoint of, and oriented parallel to, the data line, as read from the bottom of graph. Data line labels and values shall be prepared in accordance with the graphical standards as shown in Figure E-1 and Figure E-2. Labels shall minimally obscure the grids. Data line labels and values shall be located according to the following order of preference:

- a. Parallel centered interrupting the line, alternately staggered to avoid masking a continuous area of the grid (shall be used for primary data line numbers).
- b. At the end of, and parallel to, the data line (suitable for secondary data lines).
- c. Adjacent and parallel to the data line (suitable for secondary data lines).
- d. Outside the data lines with leader lines to each data line (suitable for secondary data lines.).

E.3.2.5.13 Primary data lines. Primary data lines shall be prepared in accordance with Figure E-2. Scales shall be chosen so that the mid-range of approximately linear data are oriented at approximately 45°. Increments shall be chosen so that the majority of the data lines are separated by at least one minor grid width and no more than one major grid width. Converging data lines shall be truncated (alternately) when the separation decreases to ½-1 minor grid spacing, so that actual convergence does not occur.

E.3.2.5.14 Secondary data lines. Operating limits, restricted operating conditions, and optimum, recommended, or critical operating conditions shall be depicted, as applicable, on each graph. Secondary data lines shall be prepared in accordance with Figure E-2.

E.3.2.5.15 Layout and sizing. Scales and grid size shall be chosen to take maximum advantage of the available space to provide the most easily read graph, consistent with the previously specified range and readability requirements. Several single graphs on the same general subject may be included on a single page. For sequential graphs the following requirements apply. The general layout shall have the example text near the upper left corner of the page. The first step graph shall be near the upper right corner. The sequence shall be for the user to enter on left of first graph, move right, reflect down at right angles, reflect left, and reflect down, etc. until the primary wanted parameter is read out on the final scale. A transfer grid (in the direction of transfer only) shall be provided between each step graph. Intermediate parameters may be provided on secondary scales by continuing through the reflector data lines or by reflecting in the opposite direction to the primary direction.

E.3.2.5.16 Original graphical data designs. For original (sequential) graphical designs, the following requirements also apply.

- a. Each “known” parameter shall be used only once in the sequence, unless its use will simplify a procedure.
- b. The sequence shall proceed from the best-known (or most certain) parameter to the least certain parameter consistent with technical requirements.

MIL-PRF-63029J

APPENDIX E

- c. Each sequential stop shall reflect at right angles (90° parameter transfers only).  
“Paralleling” data transfers shall be avoided.

## MIL-PRF-63029J

## APPENDIX E

USE	PREFERRED FONT TYPE/SIZE <sup>1</sup>	CAPITALIZATION	VERTICAL SPACING/LOCATION	REMARKS
1. Title	Sans Serif Bold 12 (2pts smaller for sub-graphs)	Upper Case	Centered at top of graphic <sup>2</sup>	Includes model designator symbol if applicable
2. Sub-Title	Sans Serif Bold 10	Upper Case	Centered, 6 points below <sup>2</sup> title	Use only if required to distinguish similar graphs
3. Condition heading	Sans Serif Bold 8 (2pts smaller for sub-graphs)	Upper Case	Centered, 6 points below <sup>2</sup> title or subtitle	Separate conditions; one line desirable
4. NOTE	Sans Serif Bold 8	Upper Case		As required – Notes on graph page very undesirable – text preferred
5. Note information	Sans Serif 7	Upper and lower case	Left justified; 6 points below NOTE	Use only to prevent misuse
6. EXAMPLE	Sans Serif Bold 10	Upper Case	Centered over example text	Usually located near upper left corner of chart
7. WANTED, KNOWN and METHOD Titles	Sans Serif Bold 8	Upper Case	Indented 18 points; 12 points below previous line	
8. Wanted, Known and Method text	Sans Serif 7	Upper Case	Left justified; 6 points below title text	WANTED - Parameter names only maximum of three KNOWN – Parameter: Value, Units METHOD - One line per step Do not repeat known values
12. Primary scale values	Sans Serif Bold 8	Upper Case	One minor grid division outside grid border	Oriented to read from bottom of page
13. Primary scale titles	Sans Serif Bold 8	Upper Case	One minor grid division outside scale value numbers	Oriented to read from right (vertical scales) or bottom (horizontal scales) of page
14. Secondary scale values	Sans Serif 7	Upper Case	Two minor grid divisions outside grid border	Additional secondary scales may be added
15. Secondary scale titles	Sans Serif 7	Upper Case	One minor grid division outside scale values	
16. Primary data line labels	Sans Serif Bold X X = 1 minor grid division	Upper Case	At minor grid division outside scale values	Parallel to data lines oriented to read from bottom
17. Primary data line values	Sans Serif Bold X X = 1 minor grid division	Upper Case	Interrupting data lines near mid-point	Alternate values staggered: if negative use (-) and (+)
18. Limit line labels	Sans Serif Bold X X = 1 minor grid division	Upper Case	Parallel to limit line, near midpoint, in prohibited area	
19. Maximum Performance or Recommended Operation	Sans Serif Bold X X = 1 minor grid division	Upper Case?	Location and orientation dependent on layout	
20. Time limited or restricted operation	Sans Serif Bold X X = 1 minor grid division	Upper Case?	Parallel to limit line, at midpoint in restricted area	
21. DATA BASIS: title	Sans Serif Bold 8	Upper Case	Left justified, 6 points <sup>2</sup> above figure title	
22. Data basis text	Sans Serif 7	Upper Case	Following DATA BASIS <sup>2</sup>	Includes data type and source data document(s)

NOTES: <sup>1</sup> Size requirements apply to the final printed product. A 10% tolerance is allowed, however, deviation on any page should be in the same direction.

<sup>2</sup> Spacing is designed for heading information, Data Basis, and Figure information to be marginal copy to provide the full print area for the graph. If the full layout area is not required, or used, increase spacing to provide a balanced appearance.

### FIGURE E-1. Graphical type standards

## MIL-PRF-63029J

## APPENDIX E

	<u>USE</u>	<u>COLOR</u>	<u>LENGTH</u>	<u>WEIGHT</u>	<u>REMARKS</u>
1.	Primary Data	Black	To limits or operational range	heavy medium fine	Most even value Alternate lines Use if increments change
2.	Grid Lines	Grey	Correspond to Primary scales	medium fine	Major increments Minor increments
3.	Transfer Grid	Grey	1/3 to 1 major grid	very fine	Direction of transfer only
4.	Grid Border	Black	Primary scale length	heavy	Over outside grid
5.	Primary Scale Tick Marks	Black	½ to 1 minor grid division	heavy	Inside grid border major grid only
6.	Secondary Scale Tick Marks	Black	As required	medium (Major) fine (Minor)	Outside grid border
7.	Limit Lines	Black	As required	heavy	
8.	Maximum Performance or Recommended Operation	Black	As required	heavy medium	Major lines Use if multiple lines
9.	Restricted or Time Limited Operation	Grey	As required	fine (Border shaded)	Shaded area with black border line
10.	Extrapolated Data	Black Dashed	As required	heavy, medium, fine	Use for data beyond source data conditions
11.	Beyond Limit Data	Black Dashed	As required	heavy, medium, fine	Use for data beyond operating limits to aid interpolation

**Line Definitions**

<u>Weight</u> <sup>1</sup>	Width:	<u>inches</u>	<u>millimeters</u>	<u>points</u>
Very Fine		0.004	0.1	.29
Fine		0.008	0.2	.58
Medium		0.012	0.3	.86
Heavy		0.016	0.4	1.15
Very Heavy		0.020	0.5	1.44

Dashed: 5 to 10 x width line lengths, 3 to 5 x width gap space

Dotted: 1 to 2 x width line lengths, 2 to 3 x width gap space

NOTES: <sup>1</sup> Line weight requirements apply to the final printed product. A 20% deviation is allowed, however, deviation on any page should be in the same direction.

**FIGURE E-2. Graphical line standards**

MIL-PRF-63029J

CONCLUDING MATERIAL

CUSTODIANS:

Army-AV

PREPARING ACTIVITY

Army-AV

REVIEW ACTIVITIES:

Army-CR, TM

(Project TMSS-2014-010)

NOTE: The activities listed above were in this document as of the date of this document. Since organizations and responsibilities can change, you should verify the currency of the information above using the ASSIST Online database at <https://assist.dla.mil>.