

INCH-POUND

MIL-PRF-62410A(AT)

21 November 1995

SUPERSEDING

MIL-T-62410(AT)

14 December 1983

PERFORMANCE SPECIFICATION

TUBE ASSEMBLY METAL: SWAGED HYDRAULIC, (M1 TANK)

This specification is approved for use within U.S. Army Tank-automotive and Armaments Command, Department of the Army, and is available for use by all Departments and Agencies of the Department of Defense.

1. SCOPE

1.1 Scope. This specification covers the performance, design, and test requirements for swaged hydraulic tube assemblies which provide hydraulic fluid, under pressure, to vehicle hydraulic system components.

1.2 Classification. Tube assembly shall be swaged, separable, flareless type, and threaded one end to allow connection to standard fitting (see 6.2).

Beneficial comments (recommendations, additions, deletions) and any pertinent data which may be of use in improving this document should be addressed to: U.S. Army Tank-automotive and Armaments Command, ATTN: AMSTA-TR-E/BLUE, Warren, MI 48397-5000, by using the Standardization Document Improvement Proposal (DD Form 1426) appearing at the end of this document, or by letter.

AMSC N/A

FSC 4710

DISTRIBUTION STATEMENT A. Approved for public release; distribution is unlimited.

MIL-PRF-62410A(AT)

2. APPLICABLE DOCUMENTS

2.1 General. The documents listed in this section are specified in sections 3 and 4 of this specification. This section does not include documents in other section of this specification or recommended for additional information or as examples. While every effort has been made to ensure the completeness of this list, document users are cautioned that they must meet all specified requirements documents cited in sections 3 and 4 of this specification, whether or not they are listed.

2.2 Government documents.

2.2.1 Specifications and standards. The following specifications and standards form a part of this document to the extent specified herein. Unless otherwise specified, the issues of these documents are those listed in the issue of the Department of Defense Index of Specifications and Standards (DoDISS) and supplement thereto, cited in the solicitation (see 6.2).

STANDARDS

DEPARTMENT OF DEFENSE

- | | |
|---------|---|
| MS33514 | - Fitting, End, Standard Dimension for Flareless Tube Connection and Gasket Seal. |
| MS33611 | - Tube Bend Radii. |
| MS51823 | - Nut Tube Coupling Flareless. |

(Unless otherwise indicated, copies of the above specifications and standards are available from the Standardization Document Order Desk, 700 Robbins Avenue, Building 4D, Philadelphia, PA 19111-5094.)

2.3 Non-Government publications. The following documents form a part of this document to the extent specified herein. Unless otherwise specified, the issues of the documents which are DoD adopted are those listed in the issue of the DoDISS cited in the solicitation. Unless otherwise specified, the issues of documents not listed in the DoDISS are the issues of the documents cited in the solicitation (see 6.2).

AMERICAN NATIONAL STANDARD INSTITUTE (ANSI)

- | | |
|-------|--|
| B46.1 | - Surface Texture, Surface Roughness Waviness and Lay. |
| Z1.4 | - Sampling Procedures and Tables for Inspection by Attributes. |

(Application for copies may be addressed to American National Standard Institute, 1430

MIL-PRF-62410A(AT)

Broadway, New York, NY 10018.)

AMERICAN SOCIETY FOR TESTING AND MATERIALS (ASTM)

B117 - Standard Practice For Operating Salt Spray (Fog) Testing.

(Application for copies may be obtained from the American Society for Testing and Materials, 1916 Race Street, Philadelphia, PA 19103-1187.)

2.4 Order of precedence. In the event of a conflict between the text of this specification and the references cited herein, the text of this specification shall take precedence. Nothing in this specification, however, shall supersede applicable laws and regulations unless a specific exemption has been obtained.

3. REQUIREMENTS

3.1 First article. When specified (see 6.2), a sample shall be subjected to first article inspection in accordance with 4.2.

3.2 Materials. Materials used shall be in accordance with the manufacturer's materials specification for tube assemblies. The materials shall be capable of meeting all the operational and environmental requirements specified herein. Recovered materials shall be used to the maximum extent practicable (see 4.7.1 and 4.7.2).

3.2.1 Tube. The tube shall be a corrosion-resistant material and meet the mechanical properties as specified in table I (see 4.7.1 and 4.7.2).

MIL-PRF-62410A(AT)

TABLE I. Mechanical properties of tubing.

| Nominal outside diameter (inch) (cm) | Nominal wall thickness (inch) (cm) | Ultimate tensile strength (psi) (MPa) | Yield strength 0.2 percent offset (psi) (MPa) | Elongation min (percent) | |
|--|--|--|---|-----------------------------|-------|
| | | | | Full section | Strip |
| 0.188 and less (0.477) | 0.016 and less (0.0406) over 0.016 | 75,000 (516) | ---- 30,000 min (207) | 35 | --- |
| | | 120,000 max (827) 75,000 (516) 105,000 max (723) | | | |
| Over 0.188 thru 0.500 (0.477 thru 1.27) | 0.010 and less (0.0254) over 0.010 | 75,000 | --- 30,000 min (207) | 35 | --- |
| | | 115,000 max (792) 75,000 105,000 max (723) | | | |
| Over 0.500 (1.27) | All | 75,000 (516) 100,000 max (689) | 30,000 min (207) | 35 | 30 |

3.2.2 Fitting. The fitting shall be of a corrosion-resistant material (see 4.7.1 and 4.7.2).

3.3 Design.

3.3.1 Fitting and tube assembly. The fitting and tube assembly dimensions shall be as specified (see 6.2). The fitting configuration shall be in accordance with figure 1 (see 4.7.2 and 4.7.5).

3.3.2 Fitting attachment. The fitting and the tube shall form a leak proof joint. If swaging is performed, it is recommended that the fittings be swaged on the tube by applying 5500 pounds per square inch (psi) (38 MegaPascal (MPa)) hydrostatic pressure on swaging dies (see 4.7.2 and 4.7.6).

3.3.3 Tube insertion length. Before attachment, the length of the tube to be inserted into the fitting shall be in accordance with table II (see 4.7.2 and 4.7.7).

MIL-PRF-62410A(AT)

TABLE II. Tube insertion length.

| Tube size O.D. (inch) (cm) | Tube insertion length (inch) (cm) | |
|-------------------------------|-----------------------------------|---------------|
| | Minimum | Maximum |
| 1/4 (0.635) | 0.615 (1.56) | 0.915 (2.32) |
| 3/8 (0.9525) | 0.690 (1.75) | 0.990 (2.51) |
| 1/2 (1.27) | 1.193 (3.03) | 1.493 (3.79) |
| 3/4 (1.905) | 1.303 (3.31) | 1.603 (4.07) |
| 1 (2.54) | 1.448 (3.68) | 1.748 (4.440) |

3.3.4 Tube bend radii. Unless otherwise specified, all tube bends shall be in accordance with MS33611 (see 4.7.2 and 4.7.8).

3.3.5 Nut. The nut on the separable fitting shall have the same thread and hex size for corresponding tube sizes in accordance with MS51823 and shall mate with fittings specified in MS33514. The nut shall be captive and swivel freely on the assembly (see 4.7.2 and 4.7.9).

3.4 Performance.

3.4.1 Leakage.

3.4.1.1 Tube assembly. When mated with appropriately sized fittings (see MS33514), the threaded and swaged assembly shall show no evidence of leakage or permanent deformation when subjected to hydrostatic pressures up to 1650 psig (11.37 MPa) (see 4.7.10).

3.4.2 Proof pressure. The tube assembly, when mated with appropriately sized fittings (see MS33514) shall withstand a 3000 psig (20.7 MPa) minimum pressure for not less than 5 minutes. There shall be no evidence of external leakage or permanent deformation (see 4.7.11).

3.4.3 Burst pressure. The tube assembly, when mated with appropriately sized fittings (see MS33514) shall withstand a minimum burst pressure of no less than 6000 psig (41.37 MPa). There shall be no evidence of external leakage or rupture at any pressure below the specified burst pressure. Assemblies used for verification of compliance to the burst pressure and endurance requirements shall be indelibly marked to prevent their use in functional systems (see 4.7.12).

3.4.4 Endurance. The tube assembly shall be capable of withstanding 200,000 impulse cycles without leakage or failure. The impulse rate shall be 65 ± 5 cycles per minute. Each cycle

MIL-PRF-62410A(AT)

shall consist of a rise from 0 pounds per square inch gage (psig) to surge pressure and back to 0 psig. The peak surge pressure shall be within a range from 2475 psig (17.06 MPa) to 2590 psig (17.85 MPa) (see 4.7.13).

3.4.5 Hydrostatic pressure resistance. Tubing shall be capable of withstanding an internal hydrostatic pressure P, without bulging, leakage, or other defects, except that any diametric permanent set shall be disregarded. Hydrostatic test pressure shall be calculated according to the following formula (see 4.7.14):

$$P = S \frac{D^2 - d^2}{D^2 + d^2}$$

where: P = test pressure in psi (MPa).

S = 30,000 psi (206.8 MPa).

D = maximum permissible outside diameter (nominal OD plus tolerance), inch (cm).

d = maximum permissible inside diameter, inch (cm), (computed as D less twice the minimum permissible wall thickness).

3.4.6 Repeated assembly. The separable tube assembly shall be capable of repeated assemblies without leakage or failure utilizing the tightening requirements as specified herein (see 4.7.15).

3.4.6.1 Assembly tightening. Fittings shall be clean at time of assembly, do not lubricate. The ferrule, nut and fitting seat shall be free from foreign materials, burrs, nicks and scratches. Figure 1 provides a visual inspection of the points that shall be in contact prior to final tightening (see 4.7.15).

MIL-PRF-62410A(AT)

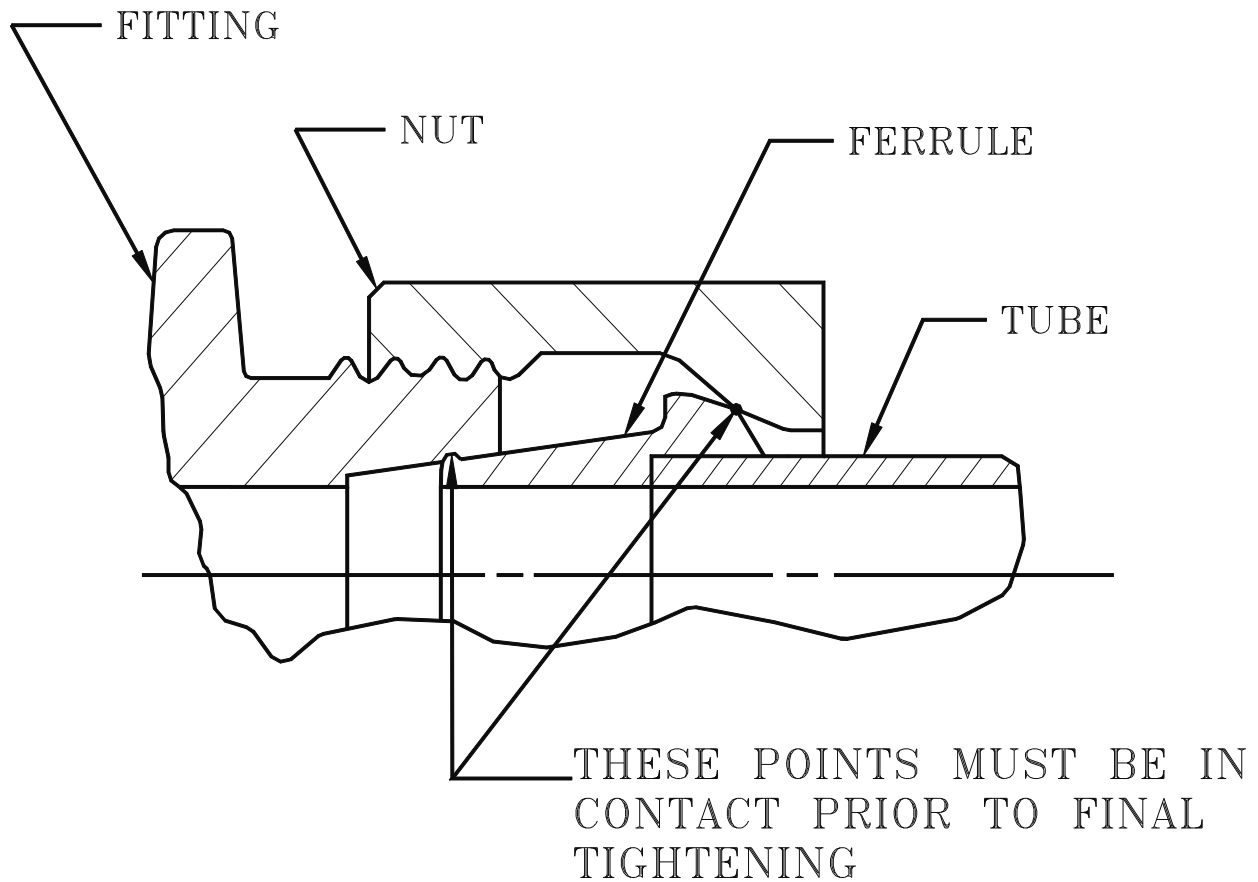
FIGURE 1. Assembly tightening.3.4.7 Environmental conditions.

3.4.7.1 Operating temperature. The tube assembly shall be capable of withstanding an operating temperature of -65 ± 2 degrees Fahrenheit ($^{\circ}\text{F}$) (-54 ± 1 degrees Celsius ($^{\circ}\text{C}$)) to $+275^{\circ}\text{F} \pm 5^{\circ}\text{F}$ ($135^{\circ}\text{C} \pm 3^{\circ}\text{C}$) for no less than 4 hours and after exposure shall not leak or fail when subjected to a proof pressure test (see 4.7.11, 4.8.2 and 4.8.3).

3.4.8 Corrosion-resistance. The tube assembly shall not be damaged nor its performance impaired after exposure to salt fog. After exposure the assembly shall not leak or fail when subjected to the proof pressure test (see 4.9).

3.4.9 Internal cleanliness. The internal tube and fitting surfaces shall meet cleanliness requirements as specified in table III (see 4.10).

MIL-PRF-62410A(AT)

TABLE III. Particle cleanliness levels.

| Level | Particle size, μm | Count per 1 ft^2 | Count per 0.1 m^2 | Count per liter |
|-------|------------------------------|----------------------------|-----------------------------|-----------------|
| 200 | 15 | 4189 | 4520 | 41890 |
| 200 | 25 | 1240 | 1340 | 12400 |
| 200 | 50 | 170 | 184 | 1700 |
| 200 | 100 | 16 | 17.3 | 160 |
| 200 | 200 | 1 | 1.08 | 10 |

3.5 Identification marking. Identification marking shall include, as a minimum, the following information permanently marked on the exterior of the tube assembly (see 4.7.2):

- a. Manufacturer's identification
- b. Serial number
- c. Military part number
- d. Federal stock number
- e. Manufacturer's part number
- f. Date of manufacture
- g. Contract number
- h. US.

3.6 Workmanship. Workmanship shall be of the quality necessary to produce tube assemblies free from defects which may affect their serviceability or reduce, limit, or compromise performance. Unless a finer finish is specified on drawings, sealing surfaces shall be smooth except that annular tool marks up to 100-microinch roughness height rating (RHR) as specified in ANSI B46.1 - 1962, will be acceptable. All other machined and bar stock flats shall be of uniform quality, condition, and shall not exceed 250 RHR (see 4.7.2).

3.7 Parts. Contractor shall supply a list and necessary data for replacement and spare parts. The contractor shall also assure that parts can be purchased using the contractors product drawing(s) and that the hardware can be built from the drawing package.

4. VERIFICATION

4.1 Classification of inspections. The inspection requirements specified herein are classified as follows:

MIL-PRF-62410A(AT)

- a. First article inspection (see 4.2).
- b. Conformance inspections (see 4.3).

4.2 First article inspection. Unless otherwise specified (see 6.2), first article inspection shall be performed on three tube assemblies when a first article sample is required (see 3.1). This inspection shall include the examinations of 4.4 (see table IV and the tests of table V).

TABLE IV. Classification of defects.

| Category | Defect | Method of examination |
|--------------|---|-----------------------|
| <u>Major</u> | | |
| 101 | Incorrect or faulty materials (see 3.2 thru 3.2.2) | Visual |
| 102 | Dimensions affecting interchangeability, not within tolerance (see 3.3 thru 3.3.5). | SIE <u>1/</u> |
| 103 | Construction not within tolerance (see 3.3 thru 3.3.5). | SIE <u>1/</u> |
| <u>Minor</u> | | |
| 201 | Dimensions not affecting interchangeability, not within tolerance (see 3.3 thru 3.3.5). | SIE <u>1/</u> |
| 202 | Incorrect or illegible marking (see 3.5). | Visual |
| 203 | Poor workmanship (see 3.6). | Visual |

1/ SIE = Standard Inspection Equipment.

TABLE V. Classification of tests.

| Title | Requirement | Test | First article <u>1/</u> | Quality conformance | |
|-----------------------|-------------|-------|-------------------------|---------------------|---------|
| | | | | Acceptance (100%) | Control |
| First article | 3.1 | 4.2 | X | X | |
| Material | 3.2 | 4.7.1 | X | X | |
| Tube | 3.2.1 | 4.7.1 | X | X | |
| Fitting | 3.2.2 | 4.7.1 | X | X | |
| Configuration | 3.3.1 | 4.7.5 | X | X | |
| Dimensions | 3.3.1 | 4.7.5 | X | | |
| Fitting attachment | 3.3.2 | 4.7.6 | X | | |
| Tube insertion length | 3.3.3 | 4.7.7 | X | | |
| Tube bend radii | 3.3.4 | 4.7.8 | X | | |

TABLE V. Classification of tests - Continued.

MIL-PRF-62410A(AT)

| Title | Requirement | Test | First article <u>1/</u> | Quality conformance | |
|----------------------------|-------------|--------|-------------------------|----------------------|---------|
| | | | | Acceptance (100%) | Control |
| Nut | 3.3.5 | 4.7.9 | X | X | X |
| Low operating temperature | 3.4.7.1 | 4.8.2 | X | X | X |
| High operating temperature | 3.4.7.1 | 4.8.3 | X | X | X |
| Corrosion resistance | 3.4.8 | 4.9 | X | X | |
| Internal cleanliness | 3.4.9 | 4.10 | X | X | |
| Leakage <u>2/</u> | 3.4.1 | 4.7.10 | X | X | |
| Tube assembly | 3.4.1.1 | 4.7.5 | X | X | |
| Proof pressure | 3.4.2 | 4.7.11 | X | | X |
| Burst pressure | 3.4.3 | 4.7.12 | X | | X |
| Endurance | 3.4.4 | 4.7.13 | X | | X |
| Repeated assembly | 3.4.6 | 4.7.15 | X | | |

1/ Place of manufacture.

2/ Leakage test (see 4.7.10) may be accomplished with proof pressure test (see 4.7.11).

4.2.1 Initial production conditions. Unless otherwise specified (see 6.2), two tube assemblies from the first 100 tube assemblies produced shall be selected for initial production inspection. This inspection shall include the examinations of 4.4 (see table IV and the tests of table V).

4.3 Conformance inspection. Conformance inspection shall include the examinations of 4.4 and the tests of 4.5 and 4.6.

4.4 Examination.

4.4.1 Sampling. Samples from an inspection lot for conformance inspection shall be selected in accordance with ANSI Z1.4. Each sample selected shall be inspected as specified herein for the defects listed in table IV. Conformance to a lot shall be accepted when zero (0) defects are found and rejected when one (1) or more defects are found.

4.5 Acceptance tests (100 percent). Each tube assembly shall be subjected to the tests specified in table V. Failure of any test shall be cause for rejection.

4.6 Control tests. The control tests shall be conducted on one tube assembly from each lot of 50 units consecutively produced except that not more than one test shall be performed in a

MIL-PRF-62410A(AT)

two month period nor less than one test in a six month period. The tube assemblies shall be subjected to the tests specified in table V.

4.7 Methods of inspection.

4.7.1 Materials. Conformance to 3.2 through 3.2.2 shall be determined by inspection of contractor records providing proof or certification that materials conform to requirements. Applicable records shall include drawings, specifications, design data, receiving inspection records, processing and quality control standards, vendor catalogs and certifications, industry standards, test reports, and rating data.

4.7.2 Defects. Conformance to 3.2 through 3.2.2, 3.3 through 3.3.5, 3.5 and 3.6 shall be determined by examination for the defects listed in table IV. Examination shall be visual, tactile or by measurement with standard inspection equipment.

4.7.3 Inspection conditions. Unless otherwise specified herein (see 6.2), all examinations and tests shall be performed under the following conditions:

- a. Air temperature: $73^{\circ}\text{F} \pm 18^{\circ}\text{F}$ ($23^{\circ}\text{C} \pm 10^{\circ}\text{C}$).
- b. Barometric pressure: 28.5 (+2, -3) inches (96.5 (6.77, -10.15) kilopascal (kPa)) of mercury.
- c. Relative humidity: 50 ± 30 percent.

4.7.4 Inspection equipment. The following test equipment or equivalent is recommended for use in the performance of the inspections and tests specified herein:

- a. Swage inspection profile gage - Deutsch, Number D12-9892.
- b. Tube insertion tool - Deutsch, Number D9862.
- c. Hydrostatic pressure supply unit capable of providing 0 - 10,000 psi (0 - 68.9 MPa) static pressure with instrumentation accuracy of 10 percent of the component tolerance.
- d. Standard inspection equipment.

4.7.5 Tube assembly. To determine conformance to 3.3.1, the tube assembly shall be inspected for completeness of assembly, configuration, and dimensional features of the applicable tube drawing (see figure 2).

MIL-PRF-62410A(AT)

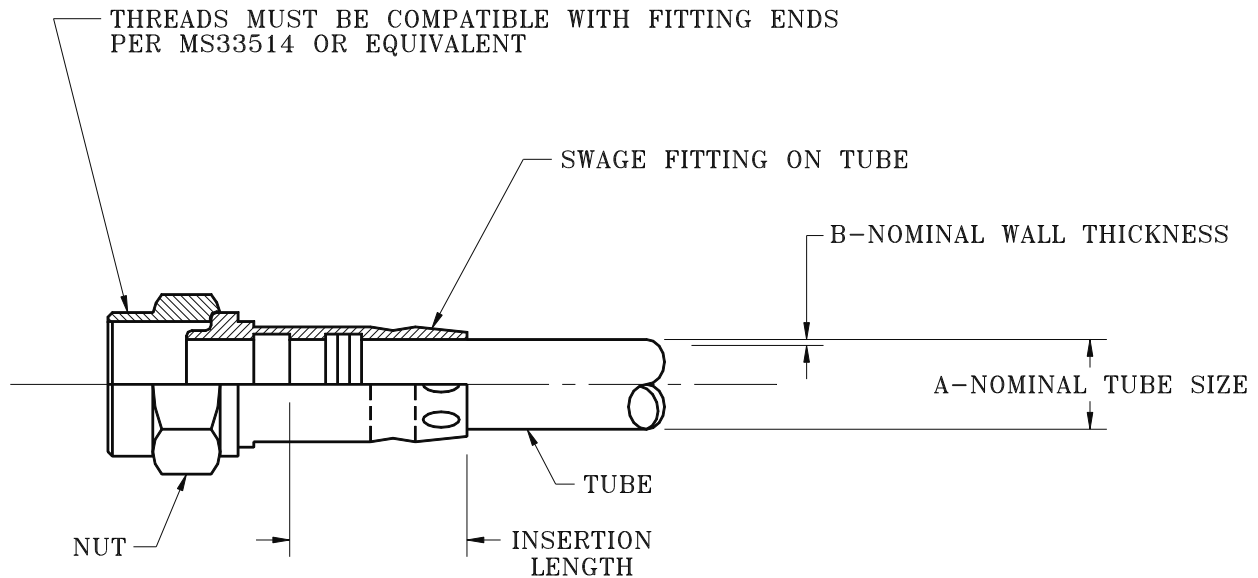
FIGURE 2. Separable fitting.

4.7.6 Fitting attachment. The leakproof requirement of the joint shall be verified during leakage (see 4.7.10) and proof tests (see 4.7.11). To determine conformance to 3.3.2, inspection shall be performed during the swage operation utilizing the appropriate size profile gage (see 4.7.3.a) to verify the proper tube insertion (tube into fitting) length and outside diameter of the swage and for visual completeness of the operation. The swage equipment hydrostatic pressure force shall be recorded and verified for conformance to 3.3.2.

4.7.7 Tube insertion length. To determine conformance to 3.3.3, inspection shall be performed using the tube insertion tool (gage) (see 4.7.4.b) to verify the tube insertion length into the fitting (see figure 2) is as specified for the applicable tube size in table I.

4.7.8 Tube bend radii. To determine conformance to 3.3.4, the tube assembly bend radii shall be inspected for conformance to requirements of MS33611 unless otherwise specified on the detailed part drawing.

4.7.9 Nut. To determine conformance to 3.3.5, the nut shall be checked for thread size with an appropriate go no go thread plug gage and a functional mating performed with the applicable fitting (see MS33514). The connecting nuts of the assembly shall be examined for being captive yet have the ability to swivel freely.

MIL-PRF-62410A(AT)

4.7.10 Leakage. To determine conformance to 3.4.1.1, connect the tube assembly to a pressure supply unit (see 4.7.4.c). Utilizing an appropriately size fitting (see MS33514), tighten the connecting nuts. Fill the tube assembly with test fluid and cap the open end after all air is removed. Pressurize slowly from 0 psig to 1650 psig (11.37 MPa) while monitoring the assembly from behind a protective enclosure. There shall be no evidence of external leakage or permanent deformation.

4.7.11 Proof pressure. To determine conformance to 3.4.2, connect the tube assembly to a pressure supply unit see MS33514), tighten connecting nuts of the assembly. Fill the tube assembly with test fluid and cap the open end after all air is removed. Pressurize at one-third rated pressure increase per minute until 3000 psig (20.7 MPa) proof pressure is attained. This pressure shall be maintained for a 5 minute period while monitoring the assembly from behind a protective enclosure. There shall be no evidence of external leakage or permanent deformation.

4.7.12 Burst pressure. To determine conformance to 3.4.3, a test shall be performed immediately after the proof pressure test of 4.7.11. Connect the tube assembly to a pressure supply unit (see 4.7.4.c). Utilizing an appropriately sized fitting (see MS33514), tighten the connecting nuts of the assembly. Fill the tube assembly with test fluid and cap the open end after all air is removed. Pressurize at one-third of pressure increase per minute for a 5 minute period while monitoring the assembly from behind a protective enclosure. There shall be no evidence of external leakage or rupture at any pressure below the specified minimum burst pressure. Assemblies used for verification of compliance to the burst pressure requirements shall be indelibly marked to prevent their use in functional systems.

4.7.13 Endurance. To determine conformance to 3.4.4, connect the tube assembly. Then connect the assembly to a high pressure impulse energy drive and subject it to 200,000 dynamic pressure impulse cycles at the pressures and rates specified in 3.4.4 and figure 3. At the conclusion of impulse cycling, the assembly shall be subjected to the proof pressure test (see 4.7.11) and examined for leakage or failure. Any evidence of leakage or failure shall be cause for rejection.

4.7.14 Hydrostatic pressure resistance. The determination of the hydrostatic pressure shall be as specified according to the formula in 3.4.5. The tubing shall be examined for bulging, leakage, and other defects or failures, except that any diametric permanent set shall be disregarded.

4.7.15 Repeated assembly. To determine conformance to 3.4.6 and 3.4.6.1, attach a non-lubricated mating fitting to each end of the tube assembly being tested. Tighten the connecting nut, then loosen the connecting nut and rotate the tube 90 degrees and retighten the connecting nut in the same manner. Repeat this procedure for eight cycles after which the assembly shall be subjected to the proof pressure test (see 4.7.11) and then the burst pressure test

MIL-PRF-62410A(AT)

(see 4.7.12). Assemblies used for verification of compliance to the endurance requirements shall be indelibly marked to prevent their use in functional systems.

4.8 Environmental tests.

4.8.1 Environmental test conditions. Unless otherwise specified, conditions for environmental tests shall be as follows:

- a. Assemblies undergoing initial production shall be subject to performance test (see table IV) prior to, during (when required in test method), and immediately following each environmental test.
- b. Assemblies undergoing acceptance tests shall have passed all acceptance tests specified in table V prior to environmental test. Tests shall be as specified herein.

4.8.2 Low operating temperature. To determine conformance to 3.4.7, the tube assembly shall be placed in an environmental test chamber and stabilized at low temperature operating conditions as specified for a period of not less than 4 hours. At completion of exposure and at the stabilized temperature, the tube assembly shall be subjected to and meet the requirements of the proof pressure test (see 4.7.11).

4.8.3 High operating temperature. To determine conformance to 3.4.7, the tube assembly shall be placed in an environmental test chamber and stabilized at high temperature operating conditions as specified for a period of not less than 4 hours. At completion of exposure and at the stabilized temperature, the tube assembly shall be subjected to and meet the requirements of the proof pressure test (see 4.7.11).

4.9 Corrosion resistance. To determine conformance to 3.4.8, tube assemblies shall be subjected to a 96-hour salt spray in accordance with ASTM B117.

4.10 Internal cleanliness. To determine conformance to 3.4.9, tube assemblies shall meet the cleanliness requirements in table III and be subject to intermittent examinations during the manufacturer's cleaning process.

5. PACKAGING

5.1 Packaging. For acquisition purposes, the packaging requirements shall be as specified in the contract or order (see 6.2). When actual packaging of materiel is to be performed by DoD personnel, these personnel need to contact the responsible packaging activity to ascertain requisite packaging requirements. Packaging requirements are maintained by the Inventory

MIL-PRF-62410A(AT)

Control Point's packaging activity within the Military Department or Defense Agency, or within the Military Department's or Defense Agency's automated packaging files, CD-ROM products, or by contacting the responsible packaging activity.

6. NOTES

(This section contains information of a general or explanatory nature which may be helpful, but is not mandatory.)

6.1 Intended use. The tube assembly is intended to provide a means for containing hydraulic fluid under pressure during transmission of the fluid between system components of the M1 tank.

6.2 Ordering data. Acquisition documents must specify the following:

- a. Title, number, and date of this specification.
- b. Issue of DoDISS to be cited in the solicitation, and if required, the specific issue of individual documents referenced (see 2.2.1 and 2.3).
- c. If first article samples shall be furnished (see 3.1).
- d. The fitting and tube assembly dimensions (see 3.3.1).
- e. If first article inspection is not required (see 4.2).
- f. If initial production inspection is not required (see 4.2.1).
- g. Inspection conditions if other than as specified (see 4.7.3).
- h. Selection of applicable packaging requirements (see 5.1).

MIL-PRF-62410A(AT)

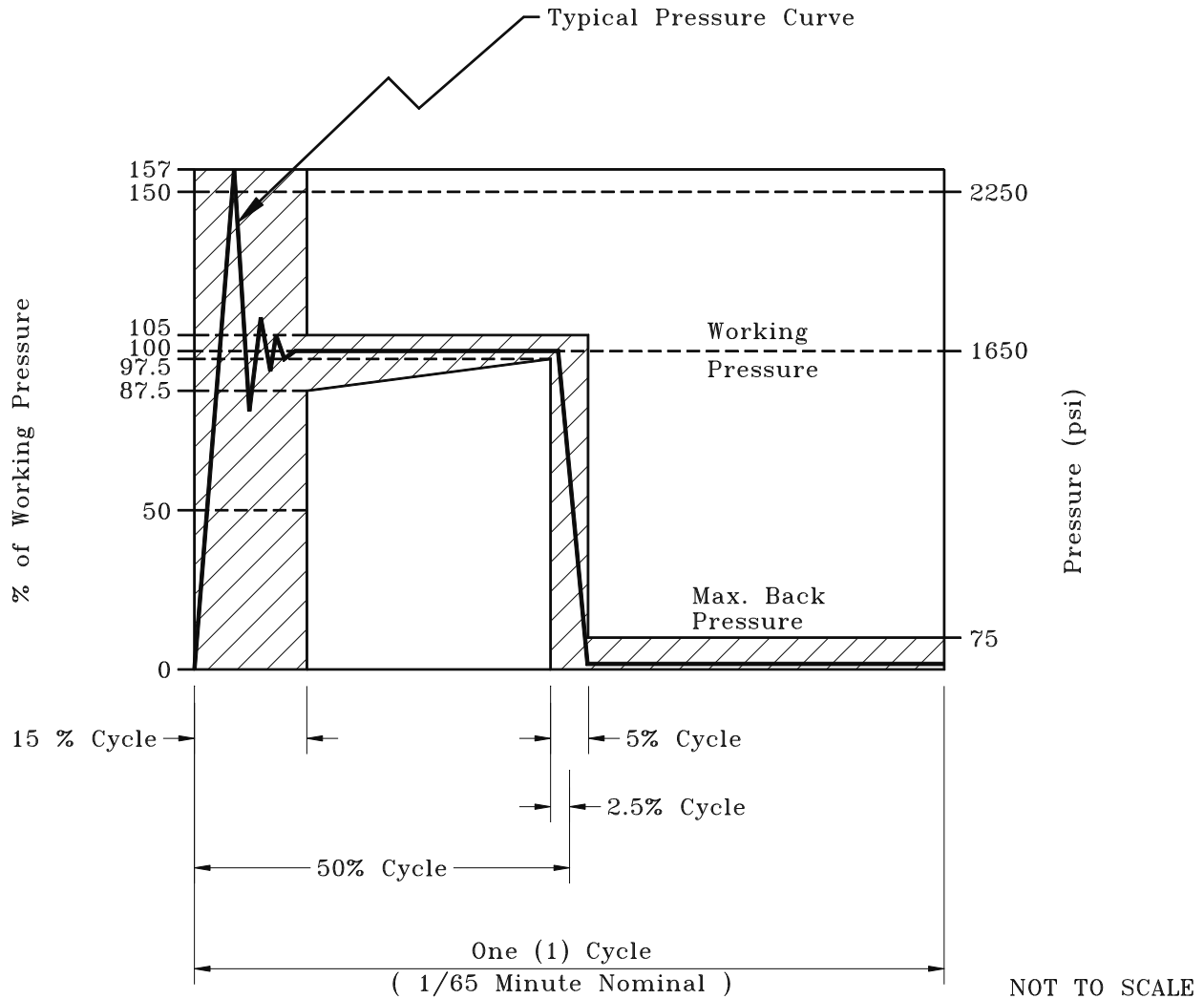

NOTE: The curve shown above represents a typical pressure-time cycle determined to be a proper severity for impulse testing. The actual pressure-time curve for impulse testing shall be confined to the shaded area indicated.

FIGURE 3. Dynamic pressure impulses.

MIL-PRF-62410A(AT)

6.3 Supersession data. This specification supersedes MIL-T-62410(AT), dated 14 December 1983.

6.4 Subject term (key word) listing.

Fitting
Hydraulic fluid
Hydrostatic pressure
Swaged hydraulic

Custodian:
Army - AT

Preparing activity:
Army - AT

(Preparing 4710-0071)