

INCH-POUND

MIL-PRF-62284A(AT)

18 December 1997

SUPERSEDING

MIL-B-62284(AT)

16 June 1983

PERFORMANCE SPECIFICATION

BLOWER ASSEMBLY, AIR CLEANER

This specification is approved for use by the U.S. Army Tank-automotive and Armaments Command, Department of the Army, and is available for use by all Departments and Agencies of the Department of Defense.

1. SCOPE

1.1 Scope. This specification covers a 1/10 horsepower (hp) continuous duty motor directly coupled to a 60 standard cubic feet per minute (stdft³/min) blower, operating from an 18 to 30 Volts direct current (V dc) power source.

2. APPLICABLE DOCUMENTS

2.1 General. The documents listed in this section are specified in sections 3 and 4 of this specification. This section does not include documents cited in other sections of this specification or recommended for additional information or as examples. While every effort has been made to ensure the completeness of this list, document users are cautioned that they must meet all specified requirement documents cited in sections 3 and 4 of this specification, whether or not they are listed.

Beneficial comments (recommendations, additions, deletions) and any pertinent data which may be of use in improving this document should be addressed to: U.S. Army Tank-automotive and Armaments Command, ATTN: AMSTA-TR-E/BLUE, Warren, MI 48397-5000, by using the Standardization Document Improvement Proposal (DD Form 1426) appearing at the end of this document, or by letter.

AMSC N/A

FSC 2940

DISTRIBUTION STATEMENT A. Approved for public release; distribution is unlimited.

MIL-PRF-62284A(AT)

2.2 Government documents.

2.2.1 Specifications, standards, and handbooks. The following specifications, standards, and handbooks form a part of this document to the extent specified herein. Unless otherwise specified, the issues of these documents are those listed in the issue of the Department of Defense Index of Specifications and Standards (DoDISS) and supplement thereto, cited in the solicitation (see 6.2).

STANDARDS

DEPARTMENT OF DEFENSE

- | | |
|-------------|---|
| MIL-STD-462 | - Electromagnetic Interference Characteristics,
(Notice 3) Measurement of (see 4.2.1). |
| MIL-STD-810 | - Environmental Test Methods and Engineering Guidelines
(see 4.2.1). |

(Unless otherwise indicated, copies of the above specifications, standards, and handbooks are available from the Standardization Document Order Desk, 700 Robbins Avenue, Building 4D, Philadelphia, PA 19111-5094.)

2.2.2 Other Government documents, drawings, and publications. The following other Government documents, drawings, and publications form a part of this document to the extent specified herein. Unless otherwise specified, the issues are those cited in the solicitation.

DRAWINGS

ARMY

- | | |
|----------|--------------------------------------|
| 10905010 | - Blower, Air Cleaner (Interface). |
| 12251905 | - Strap, Blower Motor (Interface). |
| 12251912 | - Support, Blower Motor (Interface). |

(Copies of these drawings are available from the U.S. Army Tank-automotive and Armaments Command, Warren, MI 48397-5000.)

2.3 Non-Government publications. The following documents form a part of this document to the extent specified herein. Unless otherwise specified, the issues of the documents which are DoD adopted are those listed in the issue of the DoDISS cited in the solicitation. Unless otherwise specified, the issues of documents not listed in the DoDISS are the issues of the documents cited in the solicitation (see 6.2).

MIL-PRF-62284A(AT)

AIR MOVEMENT AND CONTROL ASSOCIATION (AMCA)

Bulletin 210 - Method of Testing Fans (DoD Adopted).

(Application for copies should be addressed to the Air Movement and Control Association, 30 W. University Drive, Arlington Heights, IL 60004.)

AMERICAN SOCIETY OF HEATING, REFRIGERATION AND AIR
CONDITIONING ENGINEERS (ASHRAE)

Standard 51 - Method of Testing Fans for Rating (DoD Adopted).

(Application for copies should be addressed to the American Society of Heating, Refrigeration and Air Conditioning Engineers, 1791 Tullie Circle NE, Atlanta, GA 30329.)

AMERICAN SOCIETY FOR TESTING AND MATERIALS (ASTM)

ASTM B117 - Standard Practice for Operating Salt Spray (Fog) Apparatus (DoD Adopted).
ASTM A514 - High Yield Strength, Quenched and Tempered Alloy Steel Plate, Suitable for Welding (DoD Adopted).
ASTM A827 - Standard Specification for Plates, Carbon Steel, for Forgings and Similar Applications (DoD Adopted).
ASTM D610 - Standard Test Method for Evaluating Degree of Rusting on Painted Steel Surfaces (DoD Adopted).
ASTM D2000 - Standard Classification System for Rubber Products in Automotive Applications (DoD Adopted).

(Copies of ASTM publications may be obtained from the American Society for Testing and Materials, 100 Barr Harbor Drive, West Conshohocken, PA 19428-2959.)

2.4 Order of precedence. In the event of a conflict between the text of this document and the references cited herein, the text of this document takes precedence. Nothing in this document, however, supersedes applicable laws and regulations unless a specific exemption has been obtained.

3. REQUIREMENTS

3.1 First article. When specified (see 6.2), a sample shall be subjected to first article inspection in accordance with 4.1.1.

MIL-PRF-62284A(AT)

3.2 Design, materials, and manufacturing processes. Unless otherwise specified (see 6.2), the design, materials, and manufacturing process selection shall be the prerogative of the contractor as long as all articles submitted to the Government fully meet the operating, interface, ownership and support, and operating environment requirements specified. Asbestos and Cadmium materials shall not be used in any form in any part of the blower assembly. No item, part or assembly shall contain radioactive materials in which the specific activity is greater than 0.002 microcuries per gram or activity per item equals or exceeds 0.01 microcuries.

3.2.1 Fungistatic materials. All nonmetallic materials shall be inherently fungistatic or treated to resist fungus growth except when used for components of potted or otherwise moisture sealed assemblies.

3.2.2 Dissimilar metals. Dissimilar metals shall not be used in intimate contact unless suitably protected against electrolytic corrosion. This restriction does not apply to continuous plating, cast, inserts, or potted assemblies.

3.2.3 Recycled, recovered, or environmentally preferable materials. Recycled, recovered, or environmentally preferable materials should be used to the maximum extent possible provided that the material meets or exceeds the operational and maintenance requirements, and promotes economically advantageous life cycle costs.

3.3 Operating requirements. The blower assembly shall meet the following performance requirements:

3.3.1 Operating characteristics. The blower shall have the following operating characteristics:

- a. Rated voltage: 24 ± 0.5 V dc.
- b. Blower load current: 8 amperes (A) (max.) with 0 inch (in.) of water at blower inlet and outlet.
- c. Blower load speed: 11 500 revolutions per minute (rpm) ± 10 percent (%) with 0 in. of water at blower inlet and outlet.

3.3.2 Air flow. The blower shall meet the minimum airflow requirements of figure 1.

3.3.3 Electrical characteristics.

3.3.3.1 Dielectric strength. There shall be no damage to the dielectric material and insulation sufficient to cause failure of the blower when the blower is subjected to 500 Volts root mean square (V rms) at 60 Hertz (Hz).

MIL-PRF-62284A(AT)

3.3.3.2 Insulation resistance. The insulation resistance of the motor windings when used shall be not less than 50 megohms when tested at 500 V dc.

3.3.3.3 Transient voltage. Transients are the changing conditions of a characteristic. These usually go beyond the steady-state limits and return to and remain within the steady-state limits within a specified time period. The transient may take the form of either a surge or a spike (see figures 2 and 3). The blower shall not be damaged when subjected to a source voltage with reverse polarity.

3.3.3.3.1 Surge. A surge is a variation from the controlled steady-state level of a characteristic, resulting from the inherent regulation of the electric power supply system and remedial action by the regulator, except for battery only operation. Surge may also occur due to the application of loads in the battery only condition.

3.3.3.3.2 Spike. A spike is a high frequency oscillatory variation from the controlled steady-state level of a characteristic. It results from very high frequency currents of complex wave form produced when reactive loads are switched. An individual spike generally lasts less than 50 micro-seconds but may take up to one millisecond to decay to the steady-state level.

3.3.3.4 Starting current. The blower starting current transient shall not exceed 60 A and shall drop to 10 A, or less, within 1 second (sec) after application of input voltage. The blower shall meet these starting requirements when operating from a 24 ± 0.5 V dc power source which has an impedance of 0.13 ± 0.01 ohms.

3.4 Interface requirements.

3.4.1 Overall envelope & interfaces. The blower assembly shall fit into the air cleaner system of the M60 series tracked vehicles. The envelope dimensions and the electrical and mechanical interface locations and dimensions shall conform to drawings 10905010, 12251905, and 12251912.

3.4.2 Weight. The blower assembly, without mounting hardware, shall have a maximum weight of 8 pounds (lb).

3.4.3 Electromagnetic interference. The blower shall meet the requirements for radiated emissions in accordance with figures 4 and 5, and conducted emissions in accordance with figures 6, 7, and 8.

3.5 Ownership and support requirements. The blower assembly shall meet the following logistics requirements.

MIL-PRF-62284A(AT)

3.5.1 Endurance. The blower shall show no performance degradation after 800 hours (hr) of operation in accordance with the endurance life cycle shown in figure 9 at the input voltages in figure 10, and shall withstand random vibration with acceleration level of .003 square gravity per Hertz (g^2/Hz) ± 2 decibels (dB) between the frequencies of 10 and 500 Hz.

3.5.2 Safety. The air cleaner shall be safe to operate, and shall not subject personnel to injuries from rotating parts, burrs, or sharp edges, electrocution, etc.

3.5.3 Interchangeability. All similar parts, including repair parts, of the blower assembly furnished on the same order or built to the same drawings, shall be strictly interchangeable without the necessity of further machining, selective assembly or hand fitting of any kind.

3.5.4 Marking. Marking shall include, as a minimum, the following information permanently marked, and clearly visible on the outer surface of the assembly:

- a. Nomenclature "BLOWER ASSEMBLY, AIR CLEANER".
- b. Manufacturer's identification.
- c. When required, serial numbers shall be defined (see 6.2).
- d. Military part number.
- e. Date of manufacture.
- f. Contract number.
- g. Symbol "US".

3.6 Operating environment requirements. The blower assembly shall operate under the following environmental conditions, without degradation in performance.

3.6.1 Temperature. The blower shall meet the performance requirements specified herein at any temperature within the range of 185 degrees Fahrenheit ($^{\circ}F$) to minus (-) $65^{\circ}F$. The blower shall not be damaged by storage conditions ranging from $-65^{\circ}F$ to $185^{\circ}F$.

3.6.2 Vibration. The blower shall be capable of withstanding the vibration profile of figure 11 for a period of 120 minutes (min) (including up to 4 resonance dwells of 20 min each) in each of the three mutually perpendicular axes as shown in figure 12.

3.6.3 Shock (non-operating).

3.6.3.1 Basic intensity. The blower shall be capable of withstanding exposure to three half sine wave shock pulses of 40 ± 4 gravity units (g 's) for a duration of 18 ± 3 milliseconds (ms) applied in both directions along three mutually perpendicular axes as shown in figure 12.

MIL-PRF-62284A(AT)

3.6.3.2 High intensity. The blower shall be capable of withstanding three half sine wave shock pulses of 100 ± 10 g's for a duration of 1.0 ± 0.2 ms applied in both directions along the three mutually perpendicular axes.

3.6.4 Waterproofness. The assembly shall be capable of withstanding 6 pounds per square inch differential (psid) air pressure developed such that the blower internal air pressure exceeds the external pressure while submerged in clear water for 5 min without evidence of leakage.

3.6.5 Dust. The assembly shall be capable of operating as specified herein during the coarse dust test for 50 hr. The dust particle size and distribution by weight shall be as specified in table I.

TABLE I. Coarse dust test requirements.

Dust size (microns)	Percent dust of total weight
0 - 5	12 ± 2
5 - 10	12 ± 3
10 - 20	14 ± 3
20 - 40	23 ± 3
40 - 80	30 ± 3
80 - 200	9 ± 3

3.6.6 Humidity. The assembly shall meet the requirements specified herein after exposure to humidity conditions of 100% relative humidity.

3.6.7 Corrosion. The assembly shall be capable of operating as specified herein after exposure to a 5% sodium chloride atomized spray for 48 hr minimum.

3.6.8 Protective finish and color. Unless otherwise specified (see 6.2), the blower assembly shall be cleaned, pretreated and primed in accordance with the manufacturer's standard practice (see 6.5). The topcoat color shall be forest green.

4. VERIFICATION

4.1 Classification of inspections. The inspection requirements specified herein are classified as follows:

- a. First article inspection (see 4.1.1).
- b. Conformance inspection (see 4.1.2).

MIL-PRF-62284A(AT)

4.1.1 First article inspection. First article inspection shall be performed on the first six assemblies selected from the first ten assemblies produced (or whenever else the contract specifies) when a first article sample is required (see 3.1). This inspection shall include the verifications listed in table II.

4.1.2 Conformance inspection. Conformance inspection shall include those examinations and tests from table II as defined in the contract.

4.2 Verification methods. Acceptable verification methods included in this section are visual inspection, and measurement, sample tests, full-scale demonstration tests, simulation, modeling, engineering evaluation, component properties analysis, and similarity to previously approved or previously qualified designs.

4.2.1 Verification alternatives. The manufacturer may propose alternative test methods, techniques, or equipment, including the application of statistical process control, tool control, or cost effective sampling procedures to verify performance. See the contract for alternatives that replace verification methods required by this specification.

TABLE II. Verification methods.

Title	Requirements	Verification
Materials & dissimilar metals	3.2	4.2
<u>Operating requirements</u>	3.3	4.2.3
Operating characteristics	3.3.1	4.2.3.1
Air flow	3.3.2	4.2.3.2
Dielectric strength	3.3.3.1	4.2.3.3
Insulation resistance	3.3.3.2	4.2.3.4
Transient voltage	3.3.3.3	4.2.3.5
Starting current	3.3.3.4	4.2.3.6
<u>Interface requirements</u>	3.4	4.2.4
Overall envelope & interfaces	3.4.1	4.2.4.1
Weight	3.4.2	4.2.4.2
Electromagnetic interference	3.4.3	4.2.4.3
<u>Ownership & support requirements</u>	3.5	4.2.5
Endurance	3.5.1	4.2.5.1
Safety	3.5.2	4.2.5.2
Interchangeability	3.5.3	4.2.5.3
Marking	3.5.4	4.2.5.4

MIL-PRF-62284A(AT)

TABLE II. Verification methods - Continued.

Title	Requirements	Verification
<u>Operating environment requirements</u>	3.6	4.2.6
Temperature, high	3.6.1	4.2.6.1.1
Temperature, low	3.6.1	4.2.6.1.2
Vibration	3.6.2	4.2.6.2
Shock (non-operating)	3.6.3	4.2.6.3
Basic intensity	3.6.3.1	4.2.6.3.1
High intensity	3.6.3.2	4.2.6.3.3
Waterproofness	3.6.4	4.2.6.4
Dust	3.6.5	4.2.6.5
Humidity	3.6.6	4.2.6.6
Corrosion	3.6.7	4.2.6.7
Protective finish & color	3.6.8	4.2.6.8

4.2.2 Test methods and procedures.

4.2.2.1 Environment. Unless otherwise specified (see 6.2), all tests shall be conducted under the following conditions:

- a. Air temperature: $77 \pm 18^{\circ}\text{F}$.
- b. Barometric pressure: 28.5 (+2.0, -4.5) inches of mercury.
- c. Relative humidity: $50 \pm 30\%$.
- d. Voltage: 24.0 ± 0.5 V dc.

4.2.3 Operating requirements verification.

4.2.3.1 Operating characteristics. To determine conformance to 3.3.1, the operating test shall consist of connecting the blower to a variable dc power source and measuring load current, load speed and speed range. Failure to meet any of the listed characteristics shall cause failure of this test.

4.2.3.2 Airflow. To determine conformance to 3.3.2, the airflow test shall be accomplished utilizing a suitable proportioned, air inlet duct in accordance with ASHRAE Standard 51, and AMCA Bulletin 210, Method of Testing Fans. Airflow shall be computed in $\text{stdft}^3/\text{min}$.

4.2.3.3 Dielectric strength. To determine conformance to 3.3.3.1, the dielectric strength test shall be performed prior to final assembly on the armature and field windings separately when used. Apply 500 V rms at a frequency of 60 Hz for a period of 60 s. The test voltage shall be raised from zero to the specified value as uniformly as possible, unless otherwise specified, the

MIL-PRF-62284A(AT)

test voltage may be applied instantaneously during conformance testing. A voltmeter shall be used to measure the applied voltage to an accuracy of at least 5%. Suitable means shall be provided to indicate the occurrence of disruptive discharge, or an appropriate indicator light or an overload protective device may be used for this purpose. As a result, verify that there is no damage of dielectric material, otherwise shall constitute a failure. Upon completion of the test, the test voltage shall be gradually reduced to avoid voltage surges. The dielectric withstanding voltage test should be used with caution particularly in conformance testing, as even an overpotential less than the breakdown voltage may injure the insulation and thereby reduce its safety factor. Therefore, repeated application of the test voltage on the same value is not recommended. Care should be taken to be certain that the test voltage is free of recurring transients or high peaks.

4.2.3.4 Insulation resistance. To determine conformance to 3.3.3.2, insulation resistance shall be measured prior to final assembly on the armature and field circuit. Measurements may take 1 or 2 min to approach maximum insulation-resistance readings, provided the insulation resistance is reasonably close to steady-state value. Unless otherwise specified, the measurement error at the insulation-resistance value required shall not exceed 10%. Proper guarding techniques shall be used to prevent erroneous readings due to leakage along undesired paths. Verify that the resistance is not less than 50 megohms for the field circuit and for the armature circuit including the insulated brush holders when used.

4.2.3.5 Transient voltage. To determine conformance to 3.3.3.3, operate the blower from the indicated nominal operating voltage while applying the transient voltage for the time period designated. Repeat each test pulse every six seconds for one minute.

TABLE III. Transient voltage test.

Nominal operating voltage (V dc)	Blower voltage with transient voltage (V dc)	Transient voltage time (milliseconds, ms)
+30	+40	50
+34	+70	700
+26	+14	20
+18	+ 4	50

Operate the blower from +24 V dc power source and apply a negative voltage for two minutes, so that the net voltage at the blower is -30 V dc. After the above tests, the blower shall be subjected to the performance tests of 4.2.3.1 and 4.2.3.2.

4.2.3.6 Starting current. To determine conformance to 3.3.3.4, the starting current test shall be performed utilizing a power source having an effective impedance of 0.13 ± 0.01 ohm. Verify that starting current does not exceed 60 A and drops to 10 A or less within one second after application of input voltage.

MIL-PRF-62284A(AT)

4.2.4 Interface requirements verification.

4.2.4.1 Overall envelope & interfaces inspection. An overall envelope inspection shall be demonstrated by placement of a blower assembly in the present existing location in order to fit all physical interfaces.

4.2.4.2 Weight inspection. Verify that the blower assembly weighs 8 lb or less.

4.2.4.3 Electromagnetic interference. To determine conformance to 3.4.3, the assembly shall be subjected to the electromagnetic interference tests specified below for radiated and conducted emissions:

- Test Figure 4 to MIL-STD-462 Notice 3 or equivalent (see 4.2.1), using the test requirements for RE02 broadband.
- Test Figure 5 to MIL-STD-462 Notice 3 or equivalent (see 4.2.1), using the test requirements for RE02 narrowband.
- Test Figure 6 to MIL-STD-462 Notice 3 or equivalent (see 4.2.1), using the test requirements for CE01.
- Test Figure 7 to MIL-STD-462 Notice 3 or equivalent (see 4.2.1), using the test requirements for CE04 narrowband.
- Test Figure 8 to MIL-STD-462 Notice 3 or equivalent (see 4.2.1), using the test requirements for CE04 broadband.

4.2.5 Ownership and support requirements verification.

4.2.5.1 Endurance. To determine conformance to 3.5.1, the blower shall be mounted as shown in figure 13, or equivalent, and subjected to endurance testing as shown:

- a. Subject the blower to the performance tests of 4.2.3.1, 4.2.3.2, 4.2.3.5, and 4.2.3.6.
- b. Place the blower in a vibration/temperature chamber such that the assembly can be vibrated in the “Y” axis (see figure 12).
- c. Subject the blower to the endurance profile specified in figure 9. The duty cycle shall be 9.75 min “ON” and 0.25 min “OFF” during the blower “ON” time (see figure 9) and high temperature and dust cycling (see figure 14).
- d. Random vibration shall be at an acceleration level of $0.003 \text{ G}^2/\text{Hz} \pm 2$ decibels (dB) between the frequencies of 10 and 500 Hz. Roll off shall be 15 dB/octave below 10 Hz and -50 dB/octave above 500 Hz.
- e. After endurance testing, return the blower to room temperature and subject it to the performance tests of 4.2.3.1, 4.2.3.2, 4.2.3.5, and 4.2.3.6.

MIL-PRF-62284A(AT)

4.2.5.2 Safety inspection. Inspect blower assembly for hazardous burrs, nicks, sharp edges, foreign materials, or other imperfections that pose physical danger to personnel. Inspect blower assembly for exposed, frayed, unsecured, or otherwise improperly protected circuits that pose electrical danger to personnel.

4.2.5.3 Interchangeability inspection. To determine conformance to 3.5.3, the interchangeability between different parts, subassemblies, and assemblies having the same military part number shall be verified.

4.2.5.4 Marking. Verify the presence of the required marking on the blower assembly. After performing all environmental tests, re-inspect the blower assembly marking for readability.

4.2.6 Operating environment requirements verification.

4.2.6.1 Temperature.

4.2.6.1.1 High temperature. To determine conformance to 3.6.1, subject the blower to the high temperature test specified in MIL-STD-810, method 501.3, procedure II, or equivalent (see 4.2.1), except the temperature of step 4 shall be $185^{\circ}\text{F} \pm 5^{\circ}\text{F}$. At the conclusion of step 6, and while still at $185^{\circ}\text{F} \pm 5^{\circ}\text{F}$, subject the blower to the starting current test of 4.2.3.6. Operate the blower for one hour and subject the blower to the performance tests of 4.2.3.1 while at $185^{\circ}\text{F} \pm 5^{\circ}\text{F}$ ambient. Return the blower to room temperature and allow to stabilize prior to performing the tests of 4.2.3.1, 4.2.3.2 and 4.2.3.6.

4.2.6.1.2 Low temperature. To determine conformance to 3.6.1, subject the blower to the low temperature test specified in MIL-STD-810, method 502.3, procedure I, or equivalent (see 4.2.1). Maintain the storage temperature at $-65^{\circ}\text{F} \pm 5^{\circ}\text{F}$ for a period of 12 hr minimum, at the conclusion of this time, and while still at $-65^{\circ}\text{F} \pm 5^{\circ}\text{F}$, subject the blower to the starting current test of 4.2.3.6. Operate the blower for one hour and subject the blower to the performance tests of 4.2.3.1. Return the blower to room temperature and allow to stabilize prior to performing the tests of 4.2.3.1, 4.2.3.2, and 4.2.3.6.

4.2.6.2 Vibration. To determine conformance to 3.6.2, the blower shall be mounted to the assembly shown in figure 13, or equivalent, and subjected to the vibration test specified in MIL-STD-810, method 514.4, procedure VIII, or equivalent (see 4.2.1), except as follows:

- a. Test level shall be the vibration curve shown in figure 11. Time schedule shall be 60 min in each axis as shown in figure 12, including up to 4 resonance dwells of 10 min each.
- b. Connections and instrumentation shall be attached to the assembly to permit operating and testing as specified in c through f.

MIL-PRF-62284A(AT)

- c. Conduct resonance frequency search, along each axis at room temperature, and with the input power applied over the frequency range of 5 to 500 Hz. Up to four resonant frequencies shall be identified (the four most severe resonant frequencies if more than four are present) in each axis for the resonance dwell test.
- d. Place the blower in a $185^{\circ}\text{F} \pm 5^{\circ}\text{F}$ ambient temperature chamber and conduct sinusoidal cycling and resonance dwell tests as specified. Time schedule shall be as identified in a. above. The blower shall be operated on continuous duty at full load speed. Full load speed shall be obtained by adjustment of the line voltage to 24 ± 0.5 V dc. Verify that intermittent operation does not occur.
- e. Repeat the test described in d. above except the ambient temperature shall be $-65^{\circ}\text{F} \pm 5^{\circ}\text{F}$.
- f. After vibration, return the blower to room temperature and subject it to the performance tests of 4.2.3.1 and 4.2.3.2.

4.2.6.3 Shock.

4.2.6.3.1 Basic intensity. To determine conformance to 3.6.3.1, the blower shall be mounted to the assembly shown in figure 13, or equivalent, and subjected to the shock test specified in MIL-STD-810, method 516.4, procedure I, or equivalent (see 4.2.1). Apply three half sine wave shock pulses in both directions along the three axes as shown in figure 12. Peak amplitude shall be 40 ± 4 g's with a time duration of 18 ± 3 ms measured at the 10 % amplitude points. At the conclusion of this test, subject the blower to the performance tests of 4.2.3.1 and 4.2.3.2.

4.2.6.3.2 High intensity. To determine conformance to 3.6.3.2, the blower shall be mounted to the assembly shown in figure 13, or equivalent, and subjected to the shock test specified in MIL-STD-810, method 516.4, procedure IV, or equivalent (see 4.2.1). Apply three half sine wave shock pulses in both directions along the three axes as shown in figure 12. Peak amplitude shall be 100 ± 10 g's with a time duration of 1.0 ± 0.2 ms measured at the 10 % amplitude points. At the conclusion of this test, subject the blower to the performance tests of 4.2.3.1 and 4.2.3.2.

4.2.6.4 Waterproofness. To determine conformance to 3.6.4, the blower inlet and outlet shall not be capped, the assembly shall be submerged in water and shall not be operated during submersion. The pressure differential shall be maintained for a five minute period without evidence of leakage. Bubbles which are the result of entrapped air on exterior surfaces of the blower shall not be considered a leak. At the conclusion of this test, subject the blower to performance tests of 4.2.3.1 and 4.2.3.2.

MIL-PRF-62284A(AT)

4.2.6.5 Dust. To determine conformance to 3.6.5, the assembly shall be subjected to 50 hr of dust exposure as specified in figures 9 and 14. The assembly shall be oriented so that the inlet is exposed to the dust stream. This test shall be conducted in conjunction with the endurance test of 4.2.5.1.

4.2.6.6 Humidity. To determine conformance to 3.6.6, the blower shall be placed in a humidity chamber and subjected to the test specified in MIL-STD-810, method 507.3, procedure II, or equivalent (see 4.2.1). At the conclusion of this test, subject the blower to the performance tests of 4.2.3.1 and 4.2.3.2.

4.2.6.7 Corrosion (salt fog). To determine conformance to 3.6.7, the blower shall be subjected to the corrosion resistance test specified in ASTM B117. The assembly shall be positioned in the salt fog chamber such that the blower inlet is in the vertical position. After a 48 hr minimum exposure for salt fog, subject the blower to the performance tests of 4.2.3.1 and 4.2.3.2.

4.2.6.8 Protective finish and color. To determine conformance to 3.6.8, three test coupons of each ferrous pretreatment-primer system used shall be subjected to a 336 hr N.S.S. per ASTM B117. Test coupons shall be 4x6 in. and have the same chemistry and mill finish as the production assembly. Coating thicknesses shall reflect actual production. After removal from the salt fog the coupons shall be rinsed, dried and allowed to rest for 30 min. After the rest period a tape adhesion test with a tape having a minimum adhesion rating of 45 ounces (oz) per in. of width shall be performed on the scribe line (red corrosion must be evident at the scribe line to verify that the coupon was properly scribed). The test coupons shall show no more than 1/8 in. creepage, blistering or loss of paint adhesion at any point on the scribe line. In the field there shall be not more than a trace of film failure in accordance with ASTM D610, #9, rust and not more than 5 scattered blisters none larger than 0.04 in. (1 mm) in diameter.

5. PACKAGING

5.1 Packaging. For acquisition purposes, the packaging requirements shall be as specified in the contract or order (see 6.2). When actual packaging of materiel is to be performed by DoD personnel, these personnel need to contact the responsible packaging activity to ascertain requisite packaging requirements. Packaging requirements are maintained by the Inventory Control Point's packaging activity within the Military Department or Defense Agency, or within the Military Department's System Command. Packaging data retrieval is available from the managing Military Department's or Defense Agency's automated packaging files, CD-ROM products, or by contacting the responsible packaging activity.

MIL-PRF-62284A(AT)

6. NOTES

(This section contains information of a general or explanatory nature which may be helpful, but is not mandatory.)

6.1 Intended use. The air cleaner blower assembly covered by this specification is intended for use primarily in the M60 series tracked vehicle air cleaner system. Air cleaner blower assembly is military unique because it must operate under extreme temperatures, and withstand the types of high shock that would be experienced on the battlefield, that exceed any commercial requirements.

6.2 Acquisition requirements. Acquisition documents must specify the following:

- a. Title, number, and date of this specification.
- b. Issue of DoDISS to be cited in the solicitation, and if required, the specific issue of individual documents referenced (see 2.2.1 and 2.3).
- c. When first article inspection is required (see 3.1).
- d. Design, materials, or manufacturing processes, if other than as specified (see 3.2).
- e. Serial numbers, if required (see 3.5.4).
- f. If protective finish and color are other than as specified (see 3.6.8).
- g. If inspection conditions should be other than as specified (see 4.2.2.1).
- h. Packaging requirements (see 5.1).

6.3 First article. When requiring a first article inspection, contracting documents should provide specific guidance to offerors. This guidance should cover whether the first article is a first article sample, a first production item, or the number of test items. These documents should also include specific instructions regarding arrangements for examinations, approval of first article test results, and disposition of first articles. Pre-solicitation documents should provide Government waiver rights for samples for first article inspection to bidders offering a previously acquired or tested product. Bidders offering such products who wish to rely on such production testing must furnish evidence with the bid that prior Government approval is appropriate for the pending contract.

6.4 Conformance inspection. Affordable conformance inspection with confidence varies depending upon a number of procurement risk factors. Some of these factors include: Contractor past performance, Government schedules and budget, product material and design maturity, manufacturing capital equipment and processes applied, the controlled uniformity of those processes, labor skill and training, and the uniformity of measuring processes and techniques. During the solicitation, contracting documents should indicate those tests desired from table II and their designated frequency based on a risk assessment for the procurement.

MIL-PRF-62284A(AT)

6.5 Protective finish. If Chemical Agent Resistant Coating (CARC) paint is required, it should be specified in the contract or order (see 6.2). Historically, CARC paint in accordance with MIL-C-46168 has been provided on the blower assembly.

6.6 Subject term (key word) listing.

Airflow
Dust remover
Inlet

6.7 Changes from previous issue. Marginal notations are not used in this revision to identify changes with respect to the previous issue due to the extent of the changes.

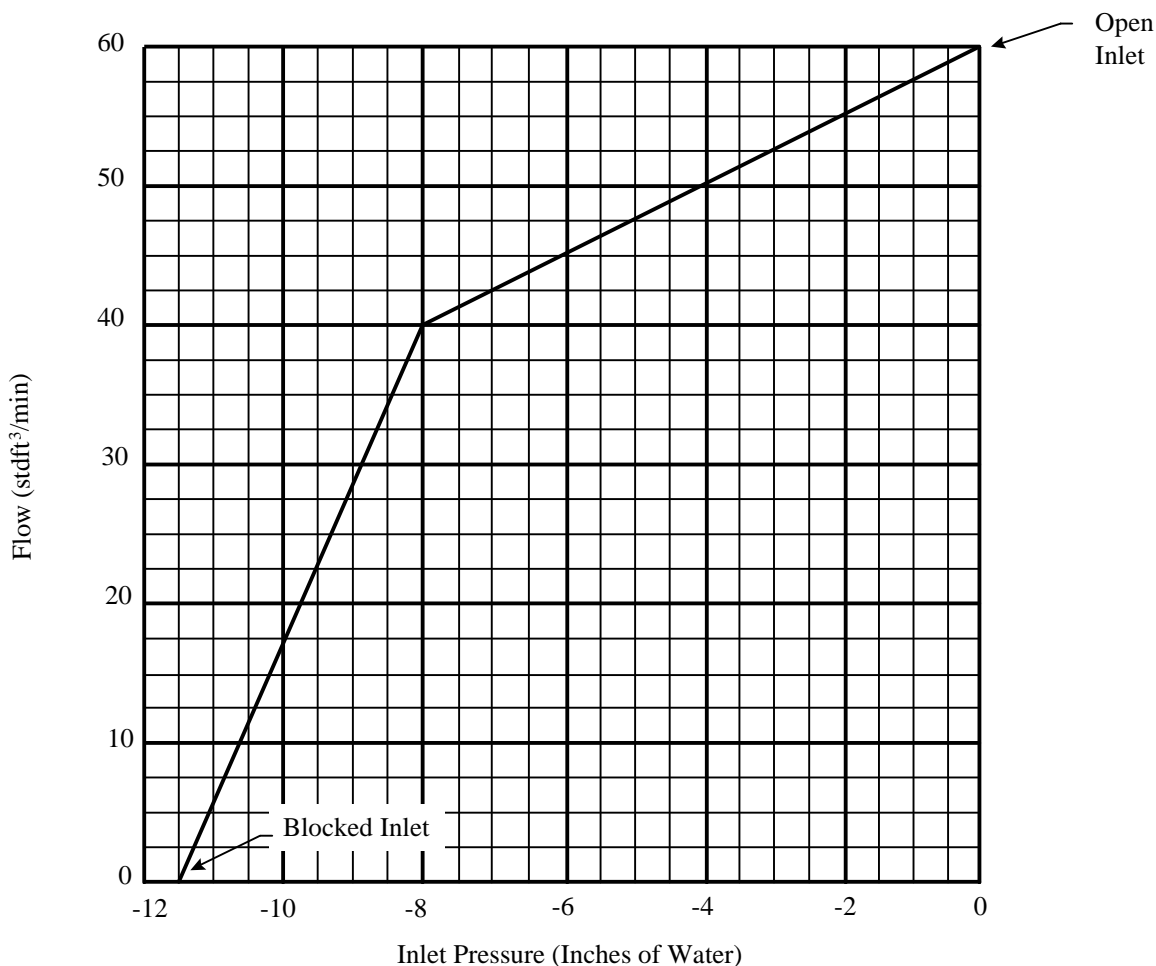

NOTE: 1. Minimum of three points are required for air flow tests.
2. Tests to be conducted at 24.0 ± 0.5 volts.

FIGURE 1. Minimum air flow.

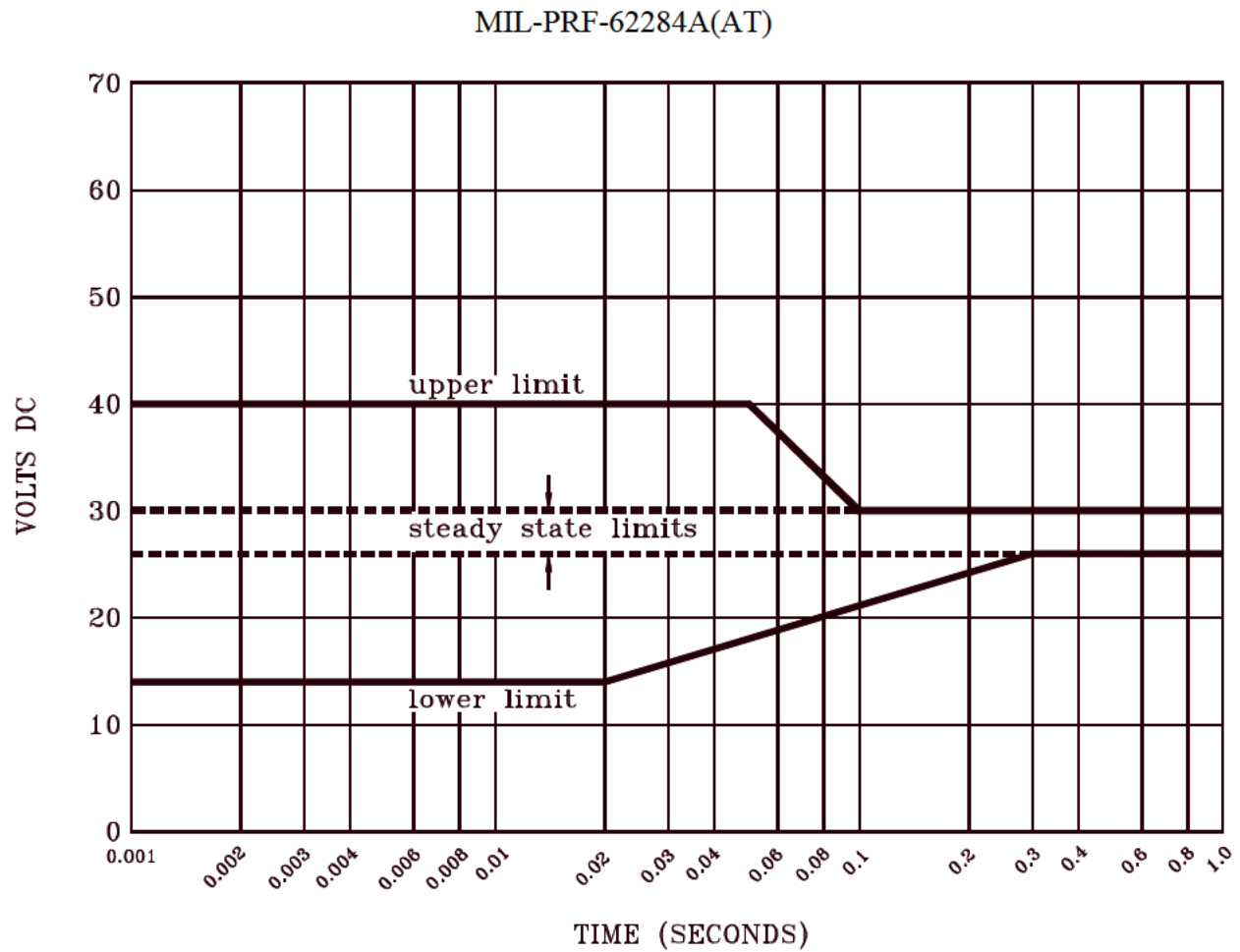

FIGURE 2. Voltage limits loci of surges for fault free operation.

MIL-PRF-62284A(AT)

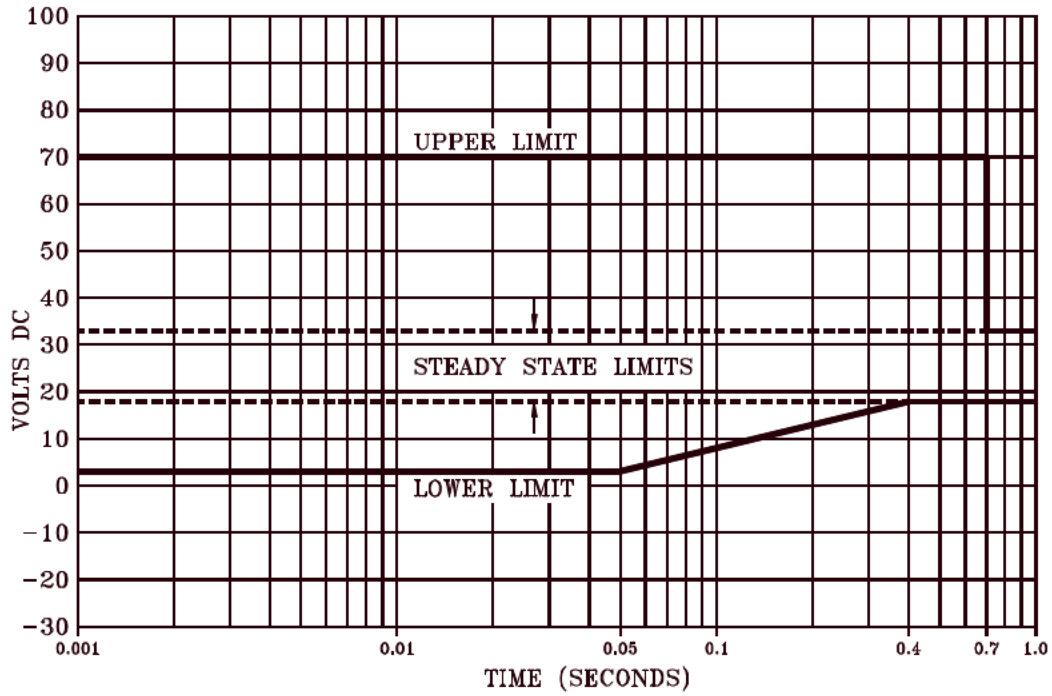

FIGURE 3. Voltage limits loci of surges for single fault condition.

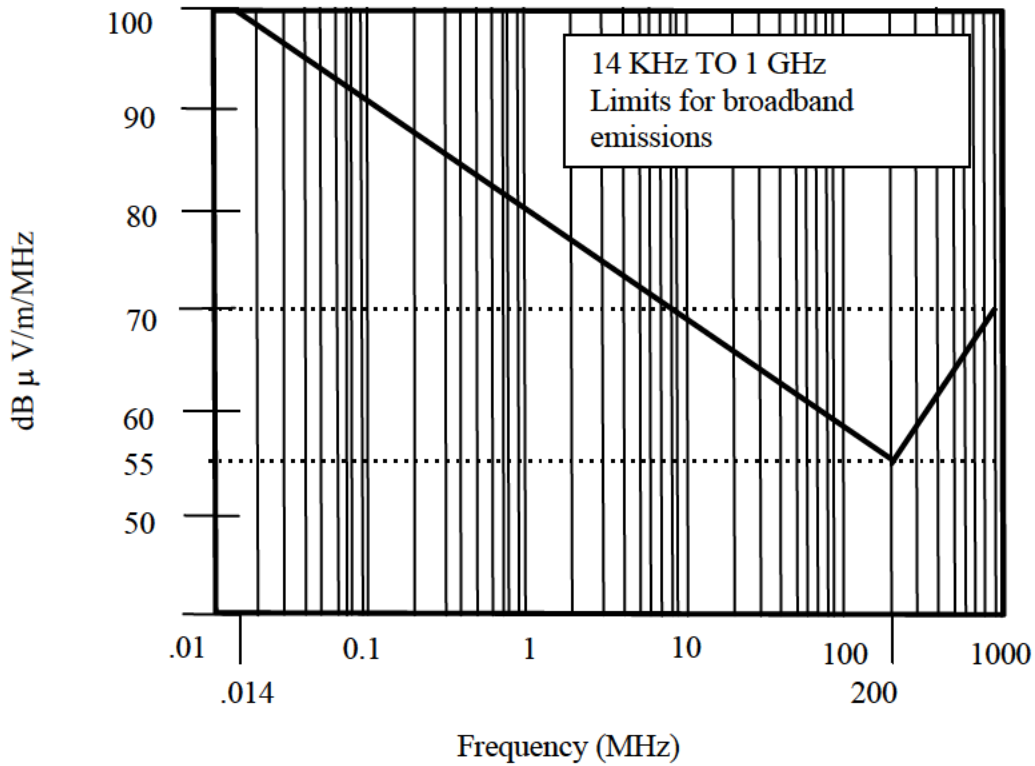
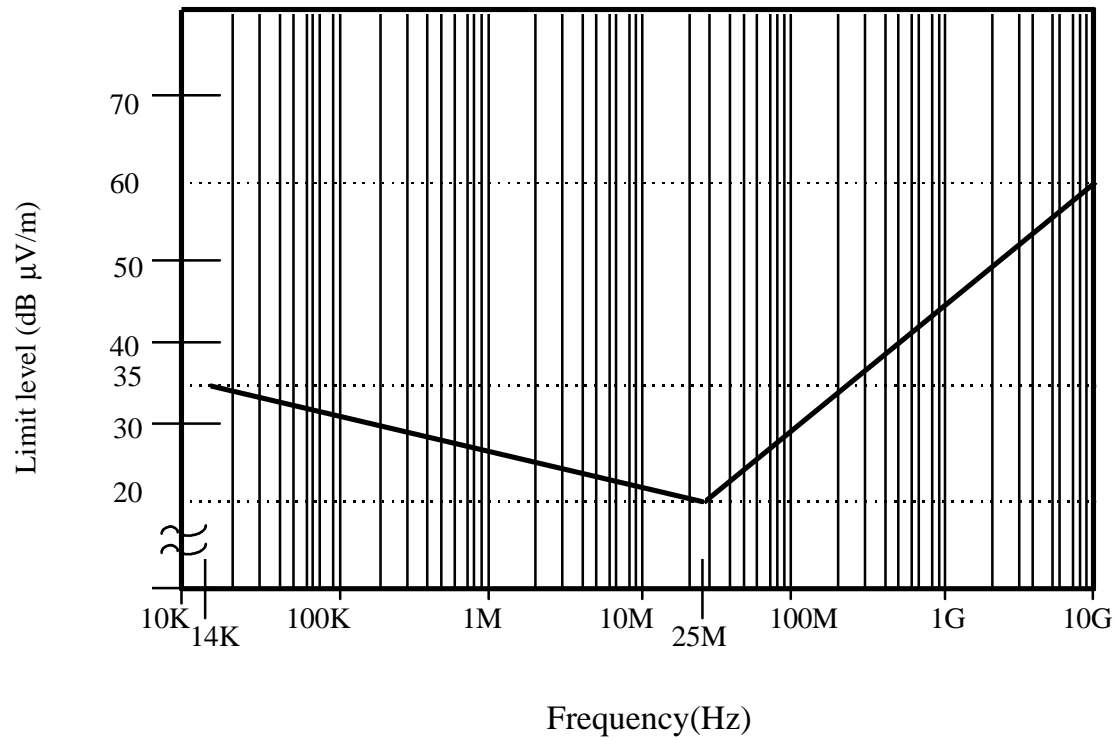

FIGURE 4. Upper limits for radiated broadband emissions.

MIL-PRF-62284A(AT)

FIGURE 5. Upper limits for radiated narrowband emissions.

MIL-PRF-62284A(AT)

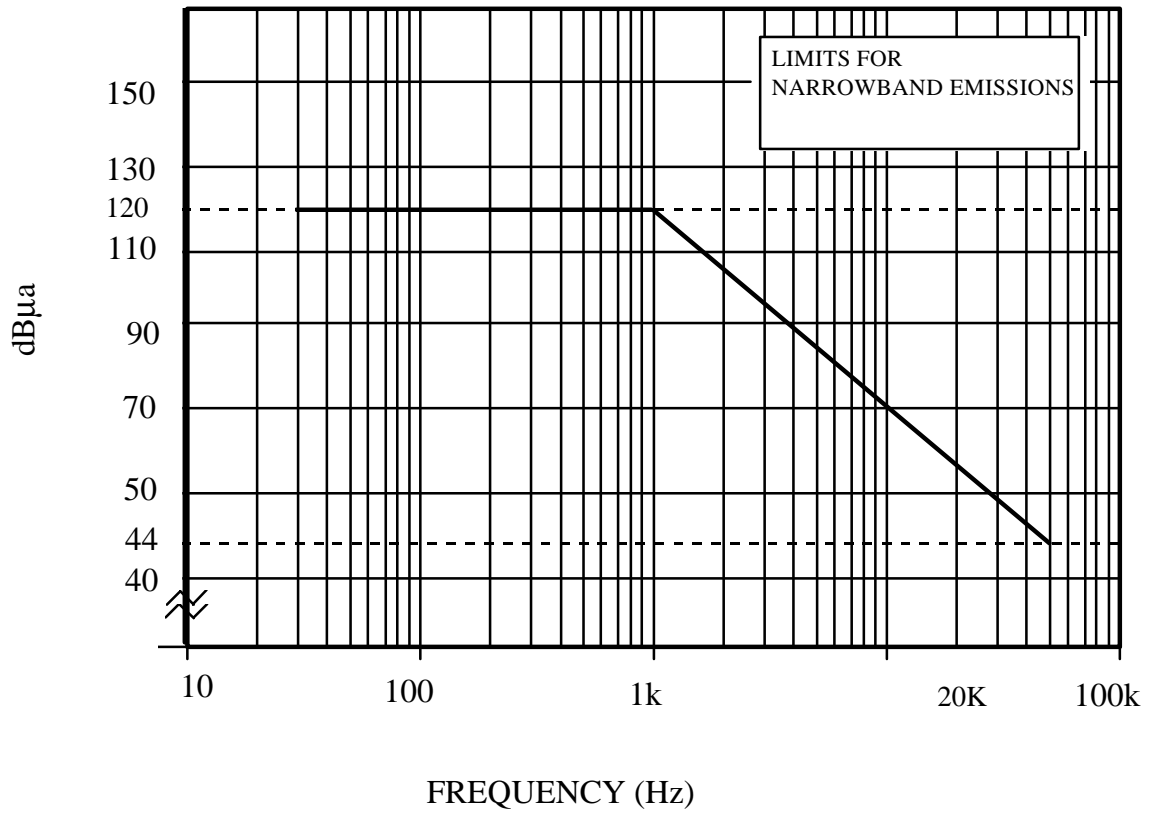
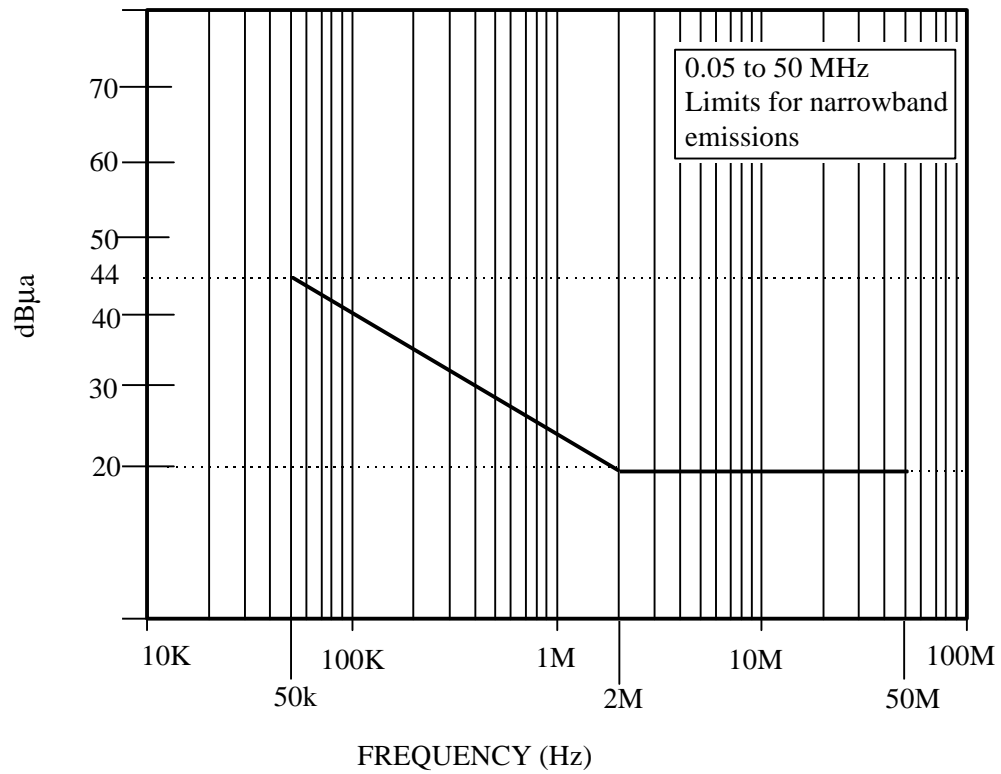

FIGURE 6. Upper limits for conducted narrowband emissions from 30 Hz to 50 KHz.

MIL-PRF-62284A(AT)

FIGURE 7. Upper limits for conducted narrowband emissions from 0.05 to 50 MHz.

MIL-PRF-62284A(AT)

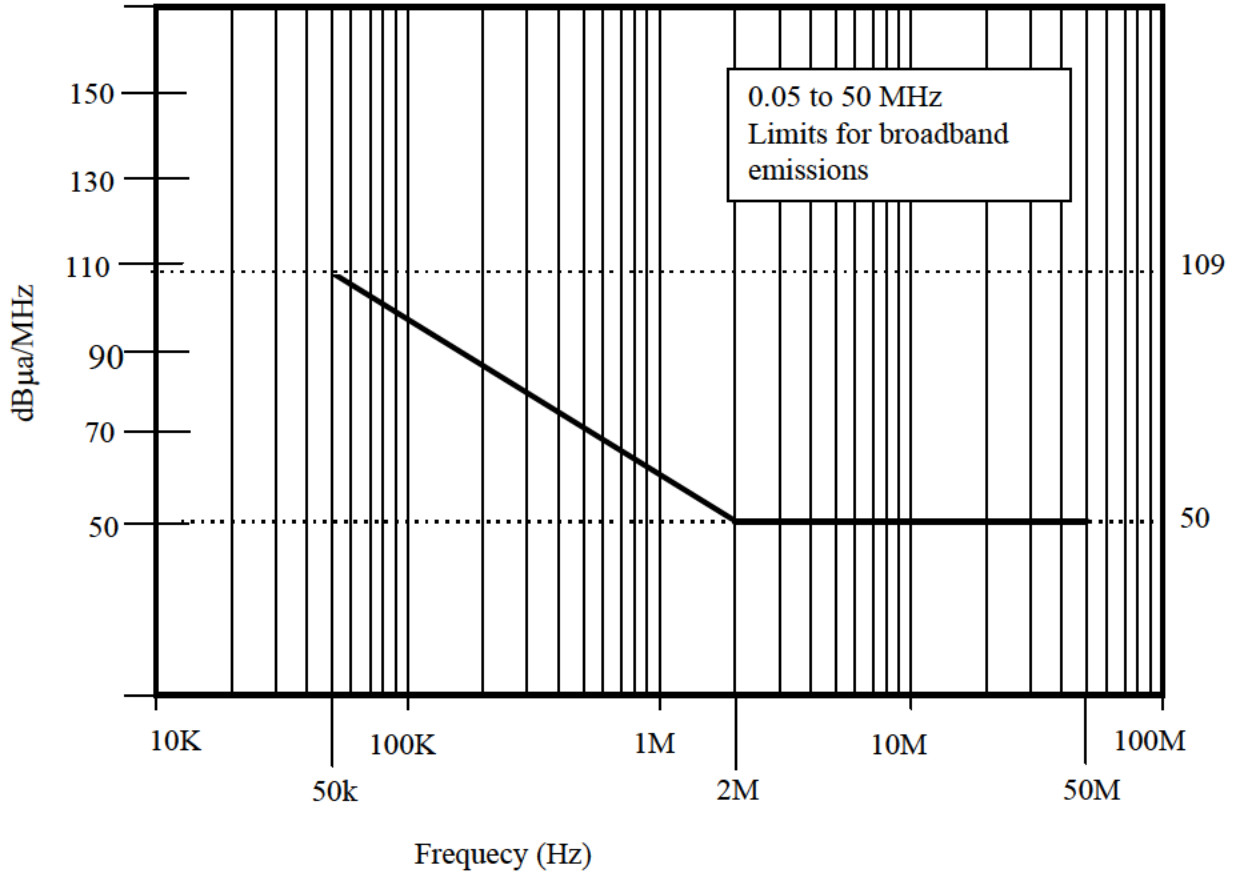
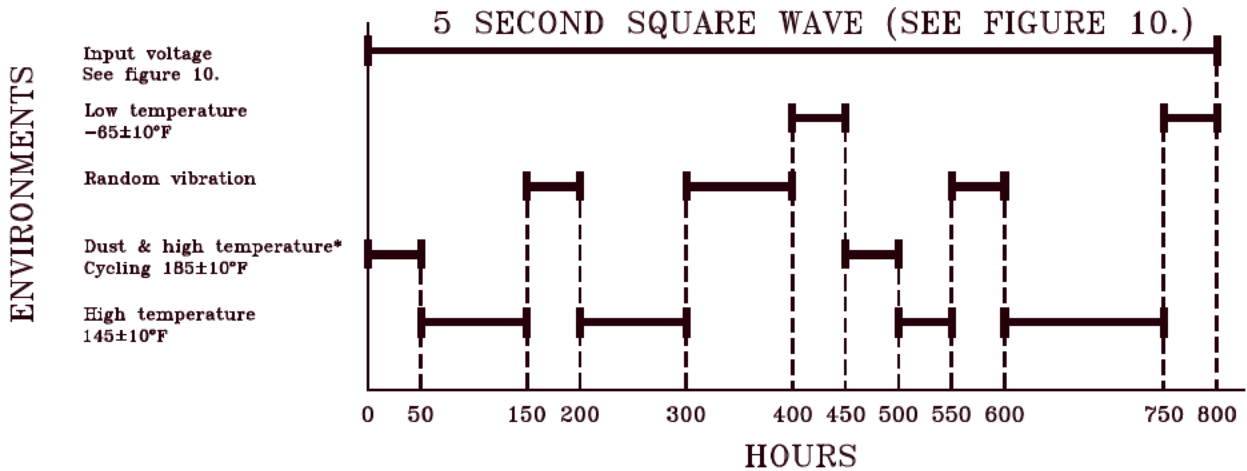

FIGURE 8. Upper limits for conducted broadband emissions from 0.05 MHz to 50 MHz.



* See figure 14.

FIGURE 9. 800 hour endurance life cycle.

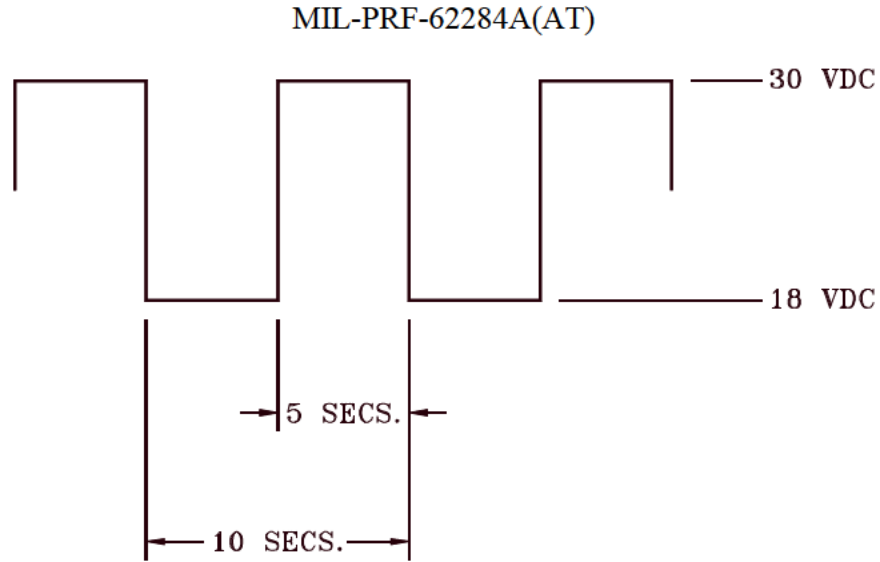

FIGURE 10. Supply voltage characteristics.

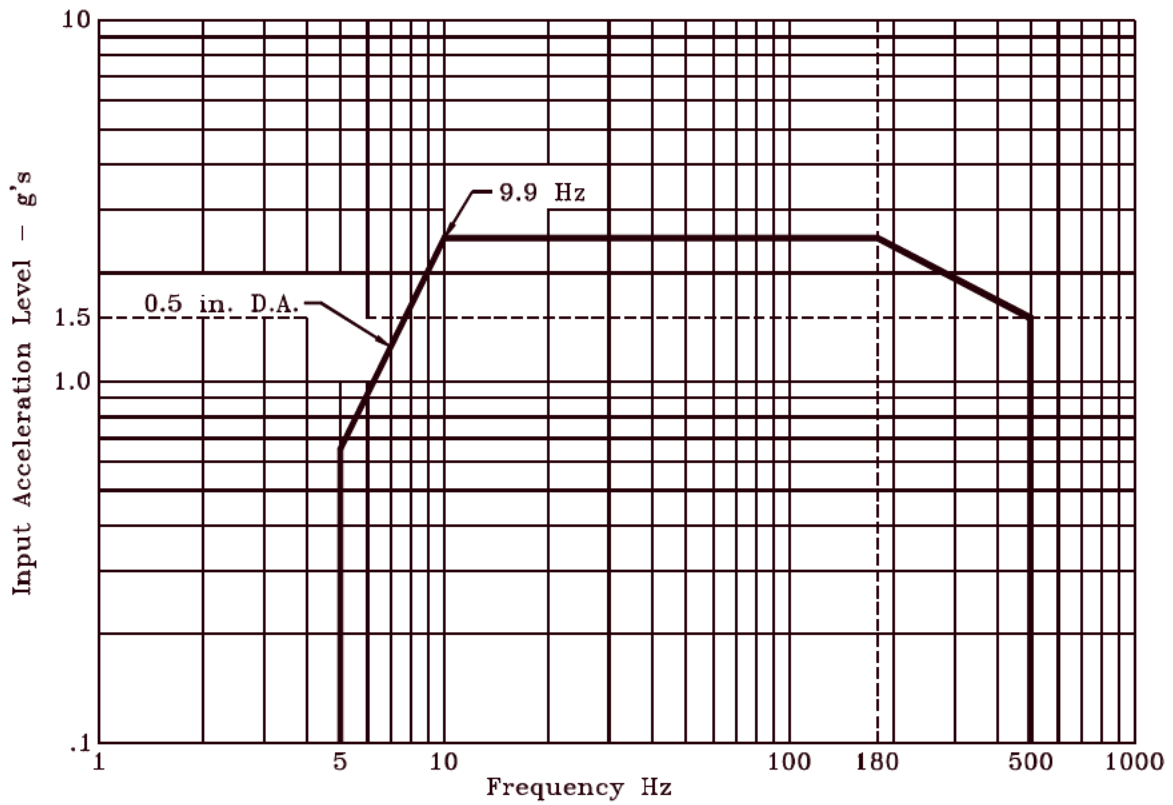
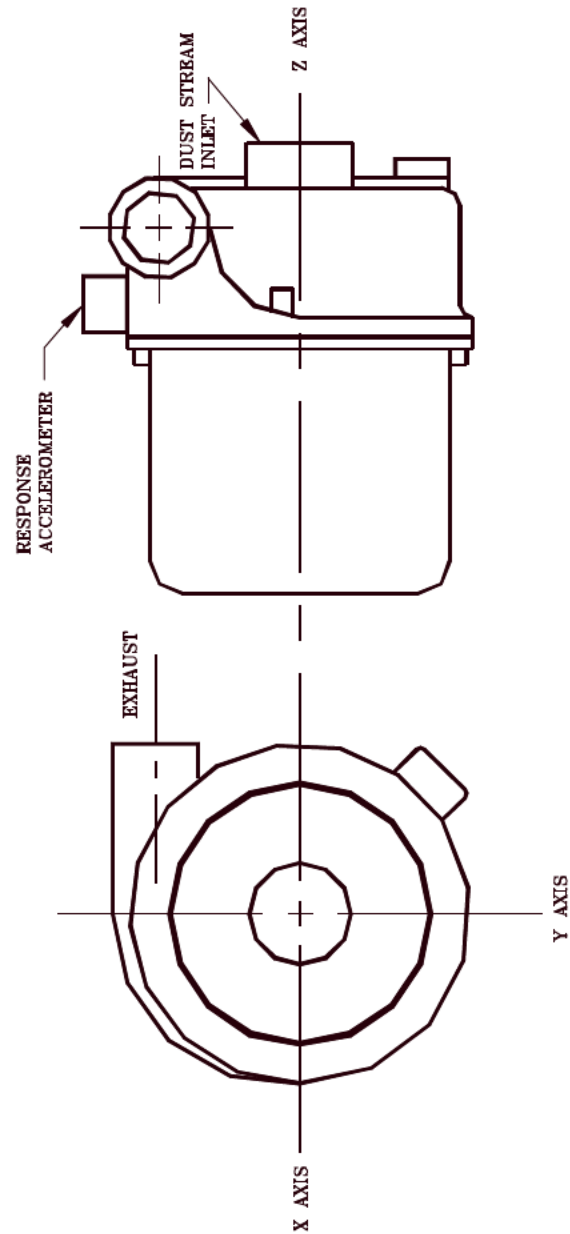

FIGURE 11. Vibration profile.

MIL-PRF-62284A(AT)



NOTE: This drawing is not intended to limit future new design of the blower assembly.

FIGURE 12. Axis identification.

MIL-PRF-62284A(AT)

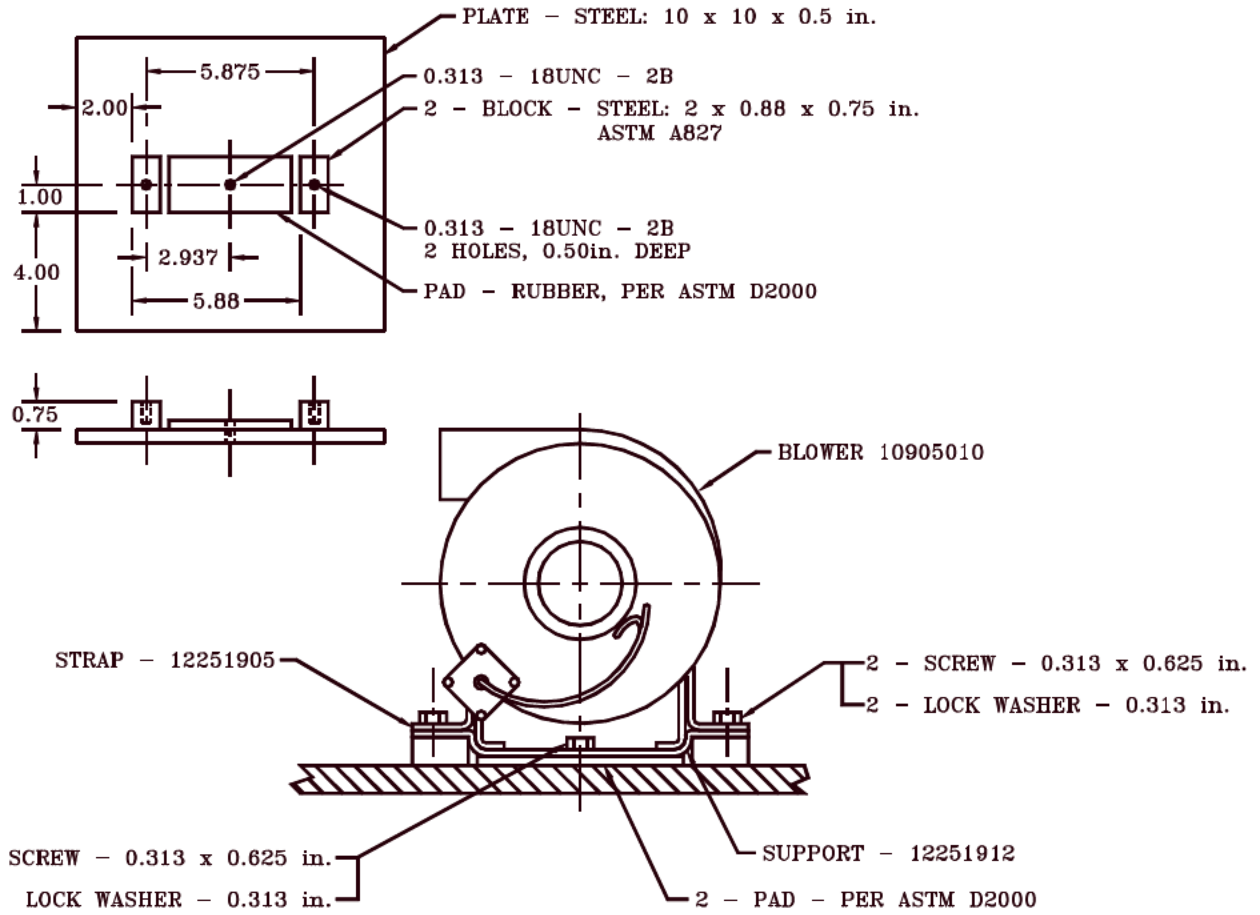

NOTE: This drawing is not intended to limit future new design of the blower assembly.

FIGURE 13. Blower assembly test mount.

MIL-PRF-62284A(AT)

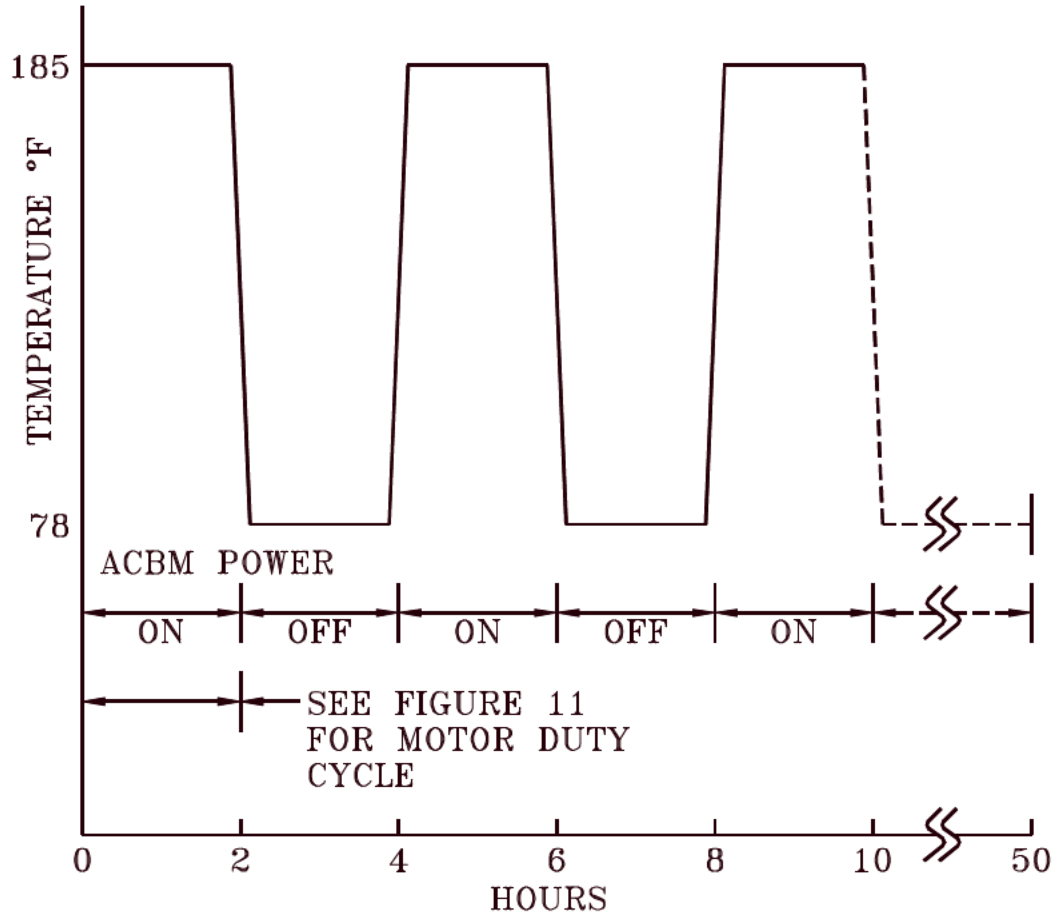

Dust feed rate during motor ON time shall be
 0.25 ± 0.025 grams/min/ft³ (10 X zero visibility)

FIGURE 14. High temperature and dust cycle during endurance life cycle test.

MIL-PRF-62284A(AT)

Custodian:
Army - AT

Preparing Activity:
Army - AT

(Project 2940-0164)

STANDARDIZATION DOCUMENT IMPROVEMENT PROPOSAL

INSTRUCTIONS

1. The preparing activity must complete blocks 1, 2, 3, and 8. In block 1, both the document number and revision letter should be given.
2. The submitter of this form must complete blocks 4, 5, and 7.
3. The preparing activity must provide a reply within 30 days from receipt of the form.

NOTE: This form may not be used to request copies of documents, nor to request waivers, or clarification of requirements on current contracts. Comments submitted on this form do not constitute or imply authorization to waive any portion of the referenced document(s) or to amend contractual requirements.

I RECOMMEND A CHANGE:
1. DOCUMENT NUMBER

MIL-PRF-62284A(AT)

2. DOCUMENT DATE (YYMMDD)

971218

3. DOCUMENT TITLE

Blower Assembly, Air Cleaner

4. NATURE OF CHANGE *(Identify paragraph number and include proposed rewrite, if possible. Attach extra sheets as needed.)*
5. REASON FOR RECOMMENDATION
6. SUBMITTER
a. NAME *(Last, First, Middle Initial)*
b. ORGANIZATION
c. ADDRESS *(Include Zip Code)*
d. TELEPHONE *(Include Area Code)*

 (1) Commercial
 (2) AUTOVON
(If applicable)
7. DATE SUBMITTED
 (YYMMDD)

8. PREPARING ACTIVITY
a. NAME
b. TELEPHONE *(Include Area Code)*

 (1) Commercial (810) 574-8745
 (2) AUTOVON 786-8745

c. ADDRESS *(Include Zip Code)*

 Commander
 U.S. Army Tank-automotive and Armaments Command
 ATTN: AMSTA-TR-E/BLUE
 Warren, MI 48397-5000

 IF YOU DO NOT RECEIVE A REPLY WITHIN 45 DAYS, CONTACT:
 Defense Quality and Standardization Office
 5203 Leesburg Pike, Suite 1403
 Falls Church, VA 22041-3466
 Telephone (703) 756-2340 AUTOVON 289-2340