

The requirements to comply with the change in test condition letter in resistance to soldering heat (4.8.13b) for unleaded capacitors must be completed by 6 months from the date of this document. Before then, use of the previous test condition (Letter B), is authorized.

INCH-POUND

MIL-PRF-55681F  
3 September 2004  
SUPERSEDING  
MIL-PRF-55681E  
3 July 1997

## PERFORMANCE SPECIFICATION

### CAPACITOR, CHIP, MULTIPLE LAYER, FIXED, CERAMIC DIELECTRIC, ESTABLISHED RELIABILITY AND NON-ESTABLISHED RELIABILITY, GENERAL SPECIFICATION FOR

This specification is approved for use by all Departments and Agencies of the Department of Defense.

#### 1. SCOPE

1.1 Scope. This specification covers the general requirements for non-established reliability (non-ER) and established reliability (ER), ceramic dielectric, multiple layer, chip capacitors. ER capacitors covered by this specification have failure rate levels (FRL) ranging from 1.0 percent to 0.001 percent per 1,000 hours. These FRLs are established at a 90-percent confidence level and maintained at a 10-percent producer's risk and are based on life tests performed at maximum rated voltage at maximum rated temperature. An acceleration factor of 8:1 has been used to relate life test data obtained at 200 percent of rated voltage at maximum rated temperature, to rated voltage at rated temperature.

#### 1.2 Classification.

1.2.1 Part or Identifying Number (PIN). The PIN is in the following form, and as specified (see 3.1).

CDR01	BX	100	A	K	Z	M
Style (1.2.1.1)	Rated temperature and voltage- temperature limits (1.2.1.2)	Capacitance (1.2.1.3)	Rated voltage (1.2.1.4)	Capacitance tolerance (1.2.1.5)	Termination finish (1.2.1.6)	Product level designator (1.2.1.7)

1.2.1.1 Style. The style is identified by the three-letter symbol "CDR" followed by a two-digit number. The letters identify non-ER and ER, ceramic dielectric, fixed, chip capacitors.

1.2.1.2 Rated temperature and voltage-temperature limits. The rated temperature and voltage-temperature limits are identified by a two-digit symbol. The first letter "B" indicates the rated temperature of -55°C to +125°C; the second letter indicates the voltage-temperature limits as shown in table I.

1.2.1.3 Capacitance. The nominal capacitance value expressed in picofarads (pF) is identified by a three-digit number; the first two digits represent significant figures and the last digit specifies the number of zeros to follow. When the nominal value is less than 10 pF, the letter "R" is used to indicate the decimal point and the succeeding digit(s) of the group represent significant figure(s). For example, 1R0 indicates 1.0 pF and 0R5 indicates 0.5 pF.

\*

Comments, suggestions, or questions on this document should be addressed to: US Army Communications-Electronics Command and Fort Monmouth, ATTN: AMSEL-LC-LEO-E-EP, Fort Monmouth, NJ 07703-5023, or e-mailed to [jeffrey.carver@mail1.monmouth.army.mil](mailto:jeffrey.carver@mail1.monmouth.army.mil). Since contact information can change, you may want to verify the currency of this address information using the ASSIST Online database at [www.dodssp.daps.mil](http://www.dodssp.daps.mil).

## MIL-PRF-55681F

TABLE I. Voltage-temperature limits.

Symbol	Capacitance change with reference to +25°C		
	Step A through step D of table XIII	Percent rated voltage	Step E through step G of table XIII
G	90 ± 20 ppm/°C	100	90 ± 20 ppm/°C
P <sup>1/</sup>	0 ± 30 ppm/°C	100	0 ± 30 ppm/°C
R	± 15 percent	100	+15, -40 percent
X	± 15 percent	100	+15, -25 percent
Z	± 15 percent	60	+15, -45 percent

<sup>1/</sup> At measurement point F of table XIII, the capacitance measurement may be ± 0.1 percent or ± 0.05 pF, whichever is greater, from the +25°C reference.

1.2.1.4 Rated voltage. The rated voltage for continuous operation at +125°C is identified by a single letter as shown in table II.

TABLE II. Rated voltage.

Symbol	Rated voltage
A	50
B	100
K	150
C	200
D	300
E	500
F	1,000
G	2,000
H	3,000
J	4,000

1.2.1.5 Capacitance tolerance. The capacitance tolerance is identified by a single letter as shown in table III.

TABLE III. Capacitance tolerance.

Symbol <sup>1/</sup>	Capacitance tolerance (±)
B	.10 pF
C	.25 pF
D	.50 pF
F	1 percent
G	2 percent
J	5 percent
K	10 percent
M	20 percent

<sup>1/</sup> Symbols B, C, and D are applicable for capacitance values of less than 10 pF only. For capacitance values of .10 pF through .50 pF, the capacitance will never be zero.

## MIL-PRF-55681F

- \* 1.2.1.6 Termination finish. The termination finish is identified by a single letter as shown in table IV. Termination types P (silver-copper-gold) and Q (palladium-gold) are no longer available due to lack of use. Only the user should make substitutions.

\* TABLE IV. Termination finish.

Symbol <u>1/</u>	Finish
M	Palladium-silver
N <u>2/</u>	Silver-nickel-gold
S	Solder coated final with a minimum of 4 percent lead
T	Silver
U	Base metallization-barrier metal-solder coated (tin/lead alloy, with a minimum of 4 percent lead) <u>3/</u>
W <u>4/</u>	Base metallization-barrier metal-tinned (tin or tin/lead alloy)
Y <u>5/</u>	Base metallization-barrier metal-tin (100 percent)
Z	Base metallization-barrier metal-tinned (tin/lead alloy, with a minimum of 4 percent lead)

- \* 1/ Terminations P and Q are no longer available.  
2/ See 6.4.1.  
3/ Solder will have a melting point of +200°C or less. Solder coat thickness will be a minimum of 60 micro-inches.  
\* 4/ Contact manufacturer for specific composition. W termination may be 100 percent tin and may promote tin whisker growth (see 6.4.2).  
\* 5/ Y termination is 100 percent tin and may promote tin whisker growth (see 6.4.2).

- 1.2.1.7 Product level designator. The product level designator is identified by a single letter as shown in table V.

TABLE V. Product level designator.

Symbol	Product level
C	non-ER
M	1.0 <u>1/</u>
P	0.1 <u>1/</u>
R	0.01 <u>1/</u>
S	0.001 <u>1/</u>

1/ FRL (percent per 1,000 hours).

## 2. APPLICABLE DOCUMENTS

2.1 General. The documents listed in this section are specified in sections 3 and 4 of this specification. This section does not include documents cited in other sections of this specification or recommended for additional information or as examples. While every effort has been made to ensure the completeness of this list, document users are cautioned that they must meet all specified requirements of the documents cited in sections 3 and 4 of this specification, whether or not they are listed.

### 2.2 Government documents.

- \* 2.2.1 Specifications, standards, and handbooks. The following specifications, standards, and handbooks form a part of this document to the extent specified herein. Unless otherwise specified, the issues of these documents are those cited in the solicitation or contract (See 6.2).

## MIL-PRF-55681F

## DEPARTMENT OF DEFENSE SPECIFICATIONS

(See supplement 1 for list of associated specification sheets.)

## DEPARTMENT OF DEFENSE STANDARDS

MIL-STD-202	-	Electronic and Electrical Component Parts, Test Methods for.
MIL-STD-690	-	Failure Rate Sampling Plans and Procedures.
MIL-STD-790	-	Standard Practice for Established Reliability and High Reliability Qualified Products List (QPL) Systems for Electrical, Electronic, and Fiber Optic Parts Specifications.
MIL-STD-810	-	Environmental Test Methods and Engineering Guidelines.

\* (Copies of these documents are available online at <http://assist.daps.dla.mil/quicksearch/> or [www.dodssp.daps.mil](http://www.dodssp.daps.mil) or from the Standardization Document Order Desk, 700 Robbins Avenue, Building 4D, Philadelphia, PA 19111-5094.)

2.3 Non-Government publications. The following documents form a part of this document to the extent specified herein. Unless otherwise specified, the issues of the documents which are DoD adopted are those listed in the issue of the DoDISS cited in the solicitation. Unless otherwise specified, the issues of documents not listed in the DoDISS are the issues of the documents cited in the solicitation (see 6.2).

## ELECTRONIC INDUSTRIES ALLIANCE (EIA)

EIA-554-1	-	Assessment of Average Outgoing Quality Levels in Parts Per Million (ppm).(DoD Adopted).
EIA-557	-	Statistical Process Control Systems. (DoD Adopted).

\* (Copies of these documents are available from <http://global.ihs.com> or Global Engineering Documents, Attn: Customer Service Department, 15 Inverness Way East, Englewood CO 80112-5776.)

\* THE INSTITUTE FOR INTERCONNECTING AND PACKAGING ELECTRONIC CIRCUITS INC. (IPC)

J-STD-004	-	Requirements for Soldering Fluxes.
J-STD-005	-	Requirements for Soldering Pastes.
J-STD-006	-	Requirements for Electronic Grade Solder Alloys and Fluxed and Non-Fluxed Solid Solders for Electronic Soldering Applications.

\* (Copies of these documents can be ordered online at [www.ipc.org](http://www.ipc.org) or from the Institute for Interconnecting and Packaging Electronic Circuits (IPC, INC.), 2215 Sanders Road, Suite 200 South, Northbrook, IL 60062.)

2.4 Order of precedence. In the event of a conflict between the text of this document and the references cited herein (except for related associated specifications, specifications sheets, or MS standards), the text of this document takes precedence. Nothing in this document, however, supersedes applicable laws and regulations unless a specific exemption has been obtained.

## 3. REQUIREMENTS

3.1 Specification sheets. The individual item requirements shall be as specified herein and in accordance with the applicable specification sheets. In the event of any conflict between requirements of this specification and the specification sheet, the latter shall govern (see 6.2).

3.2 Qualification. Capacitors furnished under this specification shall be products which are authorized by the qualifying activity for listing on the applicable qualified products list (QPL) before contract award. In addition, the manufacturer shall obtain certification from the qualifying activity that the product assurance requirements of 4.2 have been met and are being maintained. Authorized distributors who are approved to MIL-STD-790 distributor requirements by the QPL manufacturer are listed in the QPL.

## MIL-PRF-55681F

3.3 QPL system. The manufacturer shall establish and maintain a QPL system for parts covered by this specification. Requirements for this system are specified in MIL-STD-690 (ER parts only) and MIL-STD-790. In addition, the manufacturer shall establish a Statistical Process Control (SPC) and Part Per Million (ppm) system that meets the requirements specified in 3.3.1 and 3.3.2.

3.3.1 SPC system. As part of the overall MIL-STD-790 QPL system, the manufacturer shall establish a SPC system that meets the requirements of EIA-557. The manufacturer shall demonstrate control of the voltage-temperature limits of capacitance in the process.

3.3.2 PPM system. As part of the overall MIL-STD-790 QPL system, the manufacturer shall establish a ppm system for assessing the average outgoing quality of lots in accordance with EIA-554-1. Data exclusion, in accordance with EIA-554-1 may be used with approval of the qualifying activity. The ppm system shall identify the ppm rate at the end of each month and shall be based on a six month moving average. Style reporting may include both non-ER and ER style combinations.

3.4 Material. The material shall be as specified herein. However, when a definite material is not specified, a material shall be used which enables the capacitors to meet the performance requirements of this specification. Acceptance or approval of any constituent material shall not be construed as a guarantee of the acceptance of the finished product.

\* 3.4.1 Soldering flux. Soldering flux shall be in accordance with J-STD-004. No acid, acid salts, or type RA fluxes shall be used in preparation for or during soldering.

3.5 Interface and physical dimension requirements. Capacitors shall meet the interface requirements and physical dimensions specified (see 3.1).

3.5.1 Terminations. The terminations shall be of solderable metals or metal alloys. Termination finishes, as identified in 1.2.1.6, shall be as specified (see 3.1).

3.5.1.1 Reprocessing of terminations for solderability enhancement. The manufacturer may reprocess the terminations of capacitors supplied to this specification for the purpose of solderability enhancement, provided the termination process has been approved by the qualifying activity.

3.5.1.1.1 Reprocessing option. If the manufacturer reprocesses the terminations of the capacitors as a part of normal production, or as a corrective action for solderability failure, the reprocessed lot shall be subjected to the group A, subgroup 1, electrical tests.

3.6 Voltage conditioning. When tested as specified in 4.8.3, capacitors shall meet the following requirements:

a. Dielectric withstanding voltage (DWV) (at +25°C): Shall be as specified in 3.12, with the following exceptions:

- \* (1) For capacitors with a voltage rating of 500 volts, 200 percent of rated voltage shall be applied.
- \* (2) For capacitors with a voltage rating of 1,000 volts, 150 percent of rated voltage shall be applied.
- \* (3) For capacitors with a voltage rating greater than 1,000 volts, 120 percent of rated voltage shall be applied.
- (4) Not applicable if the optional voltage conditioning was performed at or above 250 percent of rated voltage.

b. Insulation resistance (IR) (at +25°C): Shall be as specified in 3.9.

c. Capacitance (at +25°C): Shall be as specified in 3.7.

d. Dissipation factor (DF) (at +25°C): Shall be as specified in 3.8.

3.7 Capacitance. When measured as specified in 4.8.4, the capacitance shall be within the applicable tolerance specified (see 3.1).

## MIL-PRF-55681F

3.8 DF. When measured as specified in 4.8.5, the DF shall not exceed 2.5 percent for the BR, BX, and BZ characteristics, 0.15 percent for the BP characteristic, and 0.05 percent for the BG characteristic.

3.9 IR. When measured as specified in 4.8.6, the IR shall be not less than the following:

- a. At +25°C (except high frequency styles) (see 3.1): 100,000 megohms or 1,000 megohm-microfarads, whichever is less.
- b. At +125°C (except high frequency styles) (see 3.1):
  - (1) BR, BX, and BZ characteristics: Shall be not less than 10,000 megohms or 100 megohm-microfarads, whichever is less (see 3.1).
  - (2) BP characteristic: Shall be not less than 1,000 megohms or 10 megohm-microfarads, whichever is less (see 3.1).
  - (3) BG characteristic: Shall be as specified (see 3.1).

3.10 Equivalent series resistance (ESR) (UHF) (when specified, see 3.1). When tested in accordance with 4.8.7, the ESR shall be less than the limits shown in appendix A, figure A-1 and figure A-2.

3.11 ESR (RF) (when specified, see 3.1). When tested in accordance with 4.8.8, the ESR shall be less than the limits shown in appendix A, figure A-3 and figure A-4.

3.12 DWV. When capacitors are tested as specified in 4.8.9, there shall be no evidence of breakdown or visible evidence of arcing or damage.

3.13 Solderability.

\* 3.13.1 Nonleaded capacitors. Capacitors shall be tested as specified in 4.8.10. Nonbarrier metal capacitors shall utilize Pb36B solder; barrier metal capacitors shall utilize Sn60A, Pb36B, or Sn63A solder (see 3.1) in accordance with J-STD-006, and the immersed metallized surface shall be at least 85 percent covered with a smooth solder coating. The remaining 15 percent of the surface may contain small pinholes or exposed termination material; however, these shall not be concentrated in one area.

3.13.2 Leaded capacitors. When leaded capacitors are tested as specified in 4.8.10, the dipped surface of the leads shall be at least 90 percent covered with a new, smooth solder coating. The remaining 10 percent may contain only small pinholes or rough spots, and these shall not be concentrated in one area. Bare base metal where the solder dip failed to cover the original coating is an indication of poor solderability and shall be cause for failure. In case of dispute, the percentage of coverage with pinholes or rough spots shall be determined by actual measurement of these areas, as compared to the total area.

3.14 Voltage-temperature limits (not applicable to high frequency capacitors). When capacitors are tested as specified in 4.8.11, the capacitance change shall not exceed the applicable limits specified in table I.

3.15 Thermal shock and immersion. When tested as specified in 4.8.12, capacitors shall meet the following requirements:

- a. Visual examination: There shall be no mechanical damage.
- b. DWV: Shall be as specified in 3.12.
- c. IR (at +25°C): Shall be not less than 30 percent of the initial requirement (see 3.9).
- d. Capacitance change:
  - (1) BR, BX, and BZ characteristics: Shall change not more than  $\pm 10$  percent from the initial measured value.

## MIL-PRF-55681F

- (2) BG and BP characteristics: Shall change not more than 0.5 percent of the nominal value or 0.5 pF, whichever is greater, from the initial measured value.

e. DF: Shall be as specified in 3.8.

3.16 Resistance to soldering heat. When tested as specified in 4.8.13, capacitors shall meet the following requirements:

- a. Visual examination: There shall be no evidence of mechanical damage or delamination or exposed electrodes. Leaching shall be a maximum of 25 percent on each edge of mounting area (see figure 1).
- b. IR (at +25°C): Shall not be less than the initial 25°C requirement.
- c. Capacitance change:
- (1) BR, BX, and BZ characteristics: Shall change not more than -1.0 percent to +6.0 percent from the initial measured value.
  - (2) BG characteristic: Shall change not more than 0.5 percent of the nominal value or 0.5 pF, whichever is greater, from the initial measured value.
  - (3) BP characteristic: Shall change not more than -1.0 percent to +2.0 percent of the nominal value or 0.5 pF, whichever is greater, from the initial measured value.
- d. DF: Shall not exceed the initial limits.

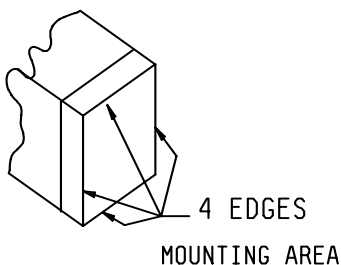

FIGURE 1. Mounting areas

3.17 Moisture resistance. When tested as specified in 4.8.14, capacitors shall meet the following requirements:

- a. Visual examination: There shall be no mechanical damage, and marking shall remain legible.
- b. DWV: Shall be as specified in 3.12.
- c. IR (at +25°C): Shall be not less than 30 percent of the initial requirement (see 3.9).
- d. Capacitance change:
- (1) BR, BX, and BZ characteristics: Shall change not more than  $\pm 10$  percent from the initial measured value.
  - (2) BP and BG characteristics: Shall change not more than 0.5 percent of the nominal value or 0.5 pF, whichever is greater, from the initial measured value.

## MIL-PRF-55681F

3.18 Humidity, steady state, low voltage. When tested as specified in 4.8.15, capacitors shall meet the following requirements:

- a. Visual examination: There shall be no mechanical damage, and marking shall remain legible.
- b. IR (at +25°C): Shall meet the initial 25°C requirement specified in 3.9.
- c. Capacitance change:
  - (1) BR, BX, and BZ characteristics: Shall not change more than  $\pm 10$  percent from the initial measured value.
  - (2) BP and BG characteristics: Shall not change more than 0.3 percent of the nominal value or 0.3 pF, whichever is greater, from the initial measured value.

3.19 Life (at elevated ambient temperature). When tested as specified in 4.8.16, capacitors shall meet the following requirements:

- a. Visual examination: There shall be no mechanical damage.
- b. IR:
  - (1) (At +25°C): Shall be not less than 30 percent of the initial requirement (see 3.9).
  - (2) (At maximum rated temperature): Shall be not less than 30 percent of the initial requirement (see 3.9).
- c. Capacitance change:
  - (1) BR, BX, and BZ characteristics: Less than  $\pm 10$  percent from the initial measured value.
  - (2) BP and BG characteristics: Shall change not more than 2.0 percent of the nominal value or 0.5 pF, whichever is greater, from the initial measured value.
- d. DF:
  - (1) BR, BX, and BZ characteristics: Less than 3.0 percent.
  - (2) BP and BG characteristics: Less than 0.2 percent.

3.20 Fungus. The manufacturer shall certify that all materials are fungus resistant or shall perform the test specified in 4.8.17. When capacitors are tested as specified in 4.8.17, examination shall not disclose evidence of fungus growth or damage.

3.21 Series resonance (when specified, see 3.1). When tested as specified in 4.8.18, capacitors shall meet or exceed the series resonance frequency as shown on figure 2.

3.22 Terminal strength (when specified, see 3.1). When capacitors are tested as specified in 4.8.19, there shall be no loosening, rupturing, or permanent damage to the terminals.

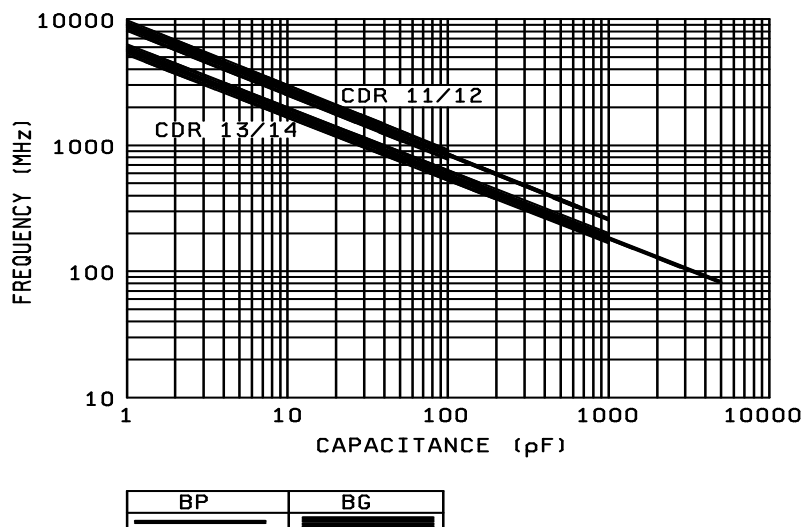

## MIL-PRF-55681F

FIGURE 2. Series resonance frequency versus nominal capacitance value.3.23 Temperature coefficient and capacitance drift (high frequency capacitors only).

3.23.1 Temperature coefficient. When capacitors are tested as specified in 4.8.20, the capacitance change shall not exceed the applicable limits specified in table I.

PPM per °C can be calculated with the following equation:

$$\text{PPM}/^{\circ}\text{C} = \frac{C_2 - C_1}{C_1(T_2 - T_1)} \times 10^6, \text{ where: } \begin{array}{l} C_2 = \text{Capacitance at test temperature} \\ C_1 = \text{Capacitance at } 25^{\circ}\text{C} \\ T_2 = \text{Test temperature} \\ T_1 = 25^{\circ}\text{C} \end{array}$$

3.23.2 Capacitance drift. The capacitance drift shall be within  $\pm$  (0.2 percent or 0.05pF), whichever is greater.

3.24 Marking (all styles except high frequency). Packaging containers shall be marked with the PIN, capacitance, capacitance tolerance, voltage, "JAN" brand, lot date code, and the Commercial and Government Entity (CAGE) code. Other markings which in any way interfere with, obscure, or confuse those specified herein are prohibited. When specified in the ordering data capacitors shall be legibly marked in accordance with table VI (see 6.2). A two character marking system shall be used. The first character shall be an alphabetic symbol and shall designate the first and second significant figures. The second character shall be a numerical digit and shall designate the decimal multiplier of capacitance in pF (Examples: A1 =  $1 \times 10^1 = 10$  pF; J5 =  $2.2 \times 10^5 = 0.22 \times 10^6 = 0.22$   $\mu$ F).

The marking shall appear in black or legible contrast. The size and orientation of the marking shall be at the option of the manufacturer. At the option of the manufacturer, the capacitor may be laser marked with the manufacturer's trademark or symbol and the capacitance code in accordance with table VI. Additional marking may appear provided that it does not interfere with the required marking.

## MIL-PRF-55681F

TABLE VI. Marking for chip capacitors.

First character				Second character	
Alphabetic character	Significant figures	Alphabetic character	Significant figures	Numerical character	Decimal multiplier
A	1.0	T	5.1	0	10 <sup>0</sup>
B	1.1	U	5.6	1	10 <sup>1</sup>
C	1.2	V	6.2	2	10 <sup>2</sup>
D	1.3	W	6.8	3	10 <sup>3</sup>
E	1.5	X	7.5	4	10 <sup>4</sup>
F	1.6	Y	8.2	5	10 <sup>5</sup>
G	1.8	Z	9.1	6	10 <sup>6</sup>
H	2.0	a	2.5	7	10 <sup>7</sup>
J	2.2	b	3.5	8	10 <sup>8</sup>
K	2.4	d	4.0	9	10 <sup>9</sup>
L	2.7	e	4.5		
M	3.0	f	5.0		
N	3.3	m	6.0		
P	3.6	n	7.0		
Q	3.9	t	8.0		
R	4.3	y	9.0		
S	4.7				

3.24.1 Marking (styles CDR11, CDR12, CDR13, CDR14, CDR21, CDR22, CDR23, CDR24, and CDR25). These capacitors shall be marked with a contrasting color dot placed on the side of the capacitor to indicate the vertical plate orientation to that side. When parts are laser marked, the marking shall be on the surface which is parallel to the plane of the embedded electrodes (this is the larger area which is normally the imprint area). If the capacitor is so marked, the vertical plate orientation is defined; therefore, the contrasting color dot on the capacitor to indicate the vertical plate orientation to that side may be an option.

Capacitors may be laser marked with the manufacturer's trademark or symbol, the two-digit or three-digit capacitance code, and the tolerance code as follows:

XXX  
100 (or A1 for two-digit)  
F

or

XXX  
100F (or A1F for two-digit)

Where space does not permit, the manufacturer's trademark or symbol may be omitted.

- \* 3.24.2 Substitutability of product levels. A manufacturer may supply to those product levels, as listed in table VII, with failure rates (FR) higher than that to which they are qualified. Parts with lower FRs are substitutable, with the user's approval, for higher FR parts, provided the lot date codes of the parts are not changed.

TABLE VII. Product level substitutability.

Parts qualified to product level	Are substitutable for product level
S (.001)	C, M, P, and R
R (.01)	C, M, and P
P (.1)	C, M
M (1)	C
C	NA

## MIL-PRF-55681F

- \* 3.24.3 Substitutability of capacitance tolerance and rated voltage. Parts qualified and marked (if applicable) to tighter capacitance tolerance or qualified to a higher rated voltage are substitutable, with the user's approval, for parts qualified and marked (if applicable) to looser capacitance tolerance, or qualified to a lower rated voltage, provided all other values, such as case size, characteristic, and leads or terminations remain the same. The substitutable parts shall not be remarked (if applicable) unless specified in the contract or order (see 6.2). In the event the capacitance tolerance is changed and remarked (if applicable) or the voltage rating is changed, the lot date codes of the parts shall not be changed and the workmanship criteria shall be met.

3.24.4 JAN and J marking. The United States Government has adopted, and is exercising legitimate control over the certification marks "JAN" and "J", respectively, to indicate that items so marked or identified are manufactured to, and meet all the requirements of specifications. Accordingly, items acquired to and meeting all of the criteria specified herein and in applicable specifications shall bear the certification mark "JAN" except that items too small to bear the certification mark "JAN" shall bear the letter "J". The "JAN" or "J" shall be placed immediately before the part number except that if such location would place a hardship on the manufacturer in connection with such marking, the "JAN" or "J" may be located on the first line above or below the part number. Items furnished under contracts or orders which either permit or require deviation from the conditions or requirements specified herein or in applicable specifications shall not bear "JAN" or "J". In the event an item fails to meet the requirements of this specification and the applicable specification sheets or associated specifications, the manufacturer shall remove completely the military part number and the "JAN" or the "J" from the sample tested and also from all items represented by the sample. The "JAN" or "J" certification mark shall not be used on products acquired to contractor drawings or specifications. The United States Government has obtained Certificate of Registration Number 504,860 for the certification mark "JAN" and Registration Number 1,586,261 for the certification mark "J".

- \* 3.25 Recycled, recovered, or environmentally preferable materials. Recycled, recovered, or environmentally preferable materials should be used to the maximum extent possible provided that the material meets or exceeds the operational and maintenance requirements, and promotes economically advantageous life cycle costs.
- \* 3.26 Workmanship. Capacitors shall be inspected to the criteria in appendix C.

#### 4. VERIFICATION

4.1 Classification of inspections. The inspections specified herein are classified as follows:

- a. Qualification inspection (see 4.4).
- b. Verification of qualification (see 4.5).
- c. Conformance inspection (see 4.6).
- d. Periodic group C inspection (see 4.7).

4.2 QPL system. The manufacturer shall establish and maintain a system to meet the requirements of MIL-STD-790 and the requirements herein (see 3.3). Evidence of such compliance shall be verified by the qualifying activity as a prerequisite for qualification and retention of qualification.

4.3 Inspection conditions and methods.

4.3.1 Inspection conditions. Unless otherwise specified herein, all inspections shall be performed in accordance with the test conditions specified in the "GENERAL REQUIREMENTS" of MIL-STD-202.

4.3.2 Methods.

4.3.2.1 Reference measurements. When requirements are based on comparative measurements made before and after conditioning, the reference measurement shall be considered the last measurement made at  $+25^{\circ}\text{C} \pm 5^{\circ}\text{C}$  prior to conditioning. Unless reference measurements have been made within 30 days prior to the beginning of conditioning, they shall be repeated.

## MIL-PRF-55681F

4.3.3 Power supply. The power supply used for life testing shall have a regulation of  $\pm 2$  percent, or less, of the applicable applied test voltage. The power supply used for dc leakage current or IR measurements shall be stabilized to at least  $\pm 100$  ppm. No voltage fluctuations shall occur during measurements that would produce a variation in the current or resistance measurement.

4.4 Qualification inspection. Qualification inspection shall be performed at a laboratory acceptable to the Government (see 6.3) on sample units produced with equipment and procedures normally used in production.

4.4.1 Sample size. The number of sample units comprising a sample of capacitors to be submitted for qualification inspection shall be as specified in table VIII, or in appendix B to this specification. The sample shall be taken from a production run and shall be produced with equipment and procedures normally used in production.

4.4.2 Inspection routine. Sample units shall be subjected to the qualification inspection specified in table VIII, in the order shown. All sample units shall be subjected to the group I tests. These sample units shall then be divided as shown in table VIII for groups II through VIII, and subjected to the tests for their particular group.

4.4.3 Failures. Failures in excess of those allowed in table VIII shall be cause for refusal to grant qualification approval.

4.4.4 FRL and quality level verification.

4.4.4.1 FR qualification and lot conformance FR inspection. FR qualification and lot conformance FR inspection shall be in accordance with the general and detailed requirements of MIL-STD-690 and the following details:

- a. Procedure I: Qualification at the initial FR level. Level M (1.0 percent) of FRSP-90 shall apply. Sample units shall be subjected to the qualification inspection specified in group I, table VIII (see 4.4.2).
- b. Procedure II: Extension of qualification to lower FR levels. To extend qualification to the P (0.1 percent), R (0.01 percent), and S (0.001 percent) FR levels, two or more voltages within a style and of similar construction may be combined. For FR levels R and S, two or more styles of similar construction (see 4.6.1.1.1) may be combined.
- c. Procedure III: Maintenance of FR level qualification. Maintenance period B of FRSP-10 shall apply. Regardless of the number of production lots produced during this period, the specified number of unit hours shall be accumulated to maintain qualification.

\* 4.4.4.2 Quality level verification. The manufacturer is responsible for establishing a quality system to assess the ppm defect level of lots. The ppm defect level shall be based on a 6-month moving average. The following groupings of styles shall be used for the maintenance of ppm defect level:

Group	Styles
1	CDR01, CDR02, CDR03, CDR04, CDR05, CDR06, CDR31, CDR32, CDR33, CDR34, CDR35
2	CDR11, CDR12, CDR13, CDR14, CDR21, CDR22, CDR23, CDR24, CDR25

## MIL-PRF-55681F

TABLE VIII. Qualification inspection.

Inspection	Requirement paragraph	Test method paragraph	Number of sample units to be inspected	Number of defectives permitted
<u>Group I</u> Voltage conditioning DWV <u>1/</u> IR (elevated temperature) <u>1/</u> Capacitance <u>1/</u> Dissipation factor <u>1/</u> IR <u>1/</u> ESR (UHF) (high frequency styles only) <u>4/</u> ESR (RF) (high frequency styles only) <u>4/</u> DWV Visual and mechanical examination	3.6 3.12 3.9 3.7 3.8 3.9 3.10 3.11 3.12 3.1, 3.4, 3.5.1, 3.24 through 3.26	4.8.3 4.8.9 4.8.6 4.8.4 4.8.5 4.8.6 4.8.7 4.8.8 4.8.9 4.8.2	85 <u>2/</u> <u>3/</u>	Not applicable
<u>Group II</u> Solderability	3.13	4.8.10	6	1
<u>Group III</u> Voltage-temperature limits <u>5/</u> Temperature coefficient and capacitance drift (high frequency only) Thermal shock and immersion	3.14 3.23 3.15	4.8.11 4.8.20 4.8.12	18	
<u>Group IV</u> Resistance to soldering heat Moisture resistance	3.16 3.17	4.8.13 4.8.14	9 9	
<u>Group V</u> Life (at elevated ambient temperature)	3.19	4.8.16	25	1
<u>Group VI</u> Fungus <u>2/</u>	3.20	4.8.17	6	0
<u>Group VII</u> Series resonance (when specified, see 3.1) Terminal strength (when specified, see 3.1)	3.21 3.22	4.8.18 4.8.19	18 <u>3/</u>	0
<u>Group VIII</u> Humidity, steady state, low voltage	3.18	4.8.15	12	0

1/ Performed as part of the voltage conditioning test.

2/ Only 79 samples are needed if certification is given for fungus (see 3.20).

3/ 18 additional samples required when group VII inspection is specified.

4/ Not applicable to high frequency styles below 1 pF.

5/ Not applicable to high frequency capacitors.

4.5 Verification of qualification. Every 6 months, the manufacturer shall provide verification of qualification to the qualifying activity. Continuation of qualification shall be based on meeting the following requirements:

- a. MIL-STD-790 program.
- b. The capacitor design has not been modified.
- c. Lot rejection for group A inspection does not exceed 10 percent or one lot, whichever is greater.
- d. Periodic group C inspection.
- e. Verification of FRLs.
- f. PPM assessment. This information shall be submitted in accordance with style groupings listed in 4.4.4.2.
- g. Continued qualification to non-ER (C level) shall be based upon continued maintenance of qualification for the ER part (FRL P).

## MIL-PRF-55681F

4.6 Conformance inspection.

4.6.1 Inspection of product for delivery. Inspection of product for delivery shall consist of group A inspection.

4.6.1.1 Inspection and production lot.

4.6.1.1.1 Inspection lot. An inspection lot shall consist of all capacitors of the same voltage-temperature characteristic, produced under essentially the same conditions with the same basic materials, and offered for inspection at one time. The samples selected from the inspection lot shall be representative of the capacitance values and voltages in the approximate ratio of production.

4.6.1.1.2 Production lot. A production lot shall consist of all capacitors of the same style, voltage rating, nominal capacitance value, voltage-temperature characteristic, and termination finish. Manufacture of all parts in the lot shall have been started, processed, assembled, and tested as a group. Lot identity shall be maintained throughout the manufacturing cycle. Non-ER and ER lots, for conformance testing, shall be kept separate.

4.6.1.2 Group A inspection.

4.6.1.2.1 Non-ER capacitors (C-level). The manufacturer shall establish and maintain an inspection system to verify that capacitors meet the capacitance, DF, IR (at 25°C), visual/mechanical, and solderability requirements. In-line or process control may be part of such system. The inspection system shall also include criteria for lot rejection and corrective actions. The inspection system shall be verified under the overall MIL-STD-790 QPL system. NOTE: Since the non-ER (C-level) is the ER design without the mandatory conformance inspection and FRL assessment, this product is still expected to meet the environmental qualification type requirements (e.g., moisture resistance, thermal shock, etc).

4.6.1.2.2 ER capacitors. Group A inspection shall consist of the examinations and tests specified in table IX, in the order shown.

4.6.1.2.3 Subgroup 1 test. Subgroup 1 test shall be performed on a production lot basis on 100 percent of the product supplied under this specification. Capacitors failing the tests of subgroup 1 shall be removed from the lot. If during the 100 percent inspection, screening requires that more than 8 percent of the capacitors be discarded, the entire production lot shall be rejected.

4.6.1.2.3.1 Manufacturer's production inspection. If the manufacturer performs tests equal to or more stringent than those specified in subgroup 1, table IX, as the final step of the production process, group A, subgroup 1 inspection may be waived. Authority to waive the subgroup 1 inspection shall be granted by the qualifying activity only. The following criteria shall be complied with:

- a. Tests conducted by the manufacturer during production shall be clearly identical to or more stringent than that specified for subgroup 1. Test conditions shall be equal to or more stringent than those specified for subgroup 1 tests. (NOTE: Includes optional voltage conditioning (see 4.8.3.2)).
- b. Manufacturer subjects 100 percent of the product supplied under this specification to his production tests.
- c. The parameters measured and the failure criteria shall be the same or more stringent than those specified herein.
- d. The lot rejection criteria is the same or more stringent than that specified herein.
- e. Once approved, the manufacturer shall not change the test procedures or criteria without prior notification and concurrence by the qualifying activity.

4.6.1.2.3.2 Rejected lots. Production lots exceeding the eight percent defective allowance (PDA) of group A, subgroup 1 inspection shall be segregated from new lots and lots that have passed inspection. Lots rejected may be offered for acceptance only if the manufacturer 100 percent retests to the requirements of subgroup 1. Resubmitted lots shall be kept separate and shall be clearly identified as resubmitted lots. If, during the 100 percent reinspection to subgroup 1, the lot exceeds 3 percent defective, the lot shall be rejected and shall not be resubmitted.

## MIL-PRF-55681F

TABLE IX. Group A inspection.

Inspection	Requirement paragraph	Test method paragraph	Sampling procedure
<u>Subgroup 1</u> Voltage conditioning <u>1/</u>	3.6	4.8.3	100 percent inspection
<u>Subgroup 2</u> IR (elevated temperature) (+125°C) Visual and mechanical examination <u>2/</u>	3.9 3.1, 3.4, 3.5, 3.5.1, 3.24 through 3.26	4.8.6 4.8.2	Table X, column A Table X, column B
<u>Subgroup 3</u> ESR (UHF) (when specified, see 3.1) <u>3/</u> ESR (RF) (when specified, see 3.1) <u>3/</u>	3.10 3.11	4.8.7 4.8.8	6 samples 0 failures
<u>Subgroup 4</u> Solderability <u>4/</u>	3.13	4.8.10	13 samples 0 failures

- 1/ For CDR11 through CDR14 and CDR21 through CDR25 capacitors of less than 10 pF, the DF shall not exceed 0.25 percent for the BP characteristic and 0.15 percent for the BG characteristic. A negative reading is not considered a failure.
- 2/ The manufacturer may request the deletion of the subgroup 2, visual and mechanical examination, provided an in-line or process control system for assessing and assuring the visual and mechanical requirements are met, can be validated and approved by the qualifying activity. Deletion of this examination does not relieve the manufacturer from meeting these requirements.
- 3/ Not applicable to styles CDR11 through CDR14 and CDR21 through CDR25 below 1 pF.
- 4/ The manufacturer may request the deletion of the subgroup 4 solderability test, provided an in-line or process control system for assessing and assuring the solderability of leads can be validated and approved by the qualifying activity. Deletion of the test does not relieve the manufacturer from meeting this test requirement.

TABLE X. Sampling plans for subgroup 2.

Lot size	Sample Size	
	A	B
1 - 13	100%	100%
14 - 125	100%	13
126 - 150	125	13
151 - 280	125	20
281 - 500	125	29
501 - 1,200	125	34
1,201 - 3,200	125	42
3,201 - 10,000	192	50
10,001 - 35,000	294	60
35,001 - 150,000	294	74
150,001 - 500,000	345	90
500,001 - up	435	102

## MIL-PRF-55681F

4.6.1.2.4 Subgroup 2 tests .

4.6.1.2.4.1 Sampling plans. Subgroup 2 tests shall be performed on an inspection lot basis. Samples subjected to subgroup 2 shall be selected in accordance with table X, based on the size of the inspection lot. In the event of one or more failures the lot shall be rejected.

4.6.1.2.4.2 Rejected lots. The rejected lot shall be segregated from new lots and those lots that have passed inspection. The rejected lot shall be 100 percent inspected for those quality characteristics found defective in the sample and any defectives found removed from the lot. A new sample of parts shall then be randomly selected in accordance with table X. If one or more defects are found in this second sample, the production lot shall be rejected and shall not be supplied to this specification.

4.6.1.2.5 Subgroup 3 tests. Subgroup 3 shall be performed on an inspection lot basis. The sampling procedure shall be as specified in table IX.

4.6.1.2.5.1 Rejected lots. The rejected lots shall be segregated from new lots and those lots that have passed inspection. Lots rejected because of failures in subgroup 3 shall be reinspected, using the sampling procedure specified in table IX. If one or more defects are found in the second sample, the lot shall be rejected and shall not be supplied to this specification. Resubmitted lots shall be kept separate from new lots, and shall be identified as resubmitted lots.

4.6.1.2.6 Subgroup 4 (solderability).

4.6.1.2.6.1 Sampling plan. Thirteen samples shall be selected randomly from every inspection lot and subjected to the subgroup 4 solderability test. The manufacturer may use electrical rejects from the subgroup 1 screening tests for all or part of the samples to be used for the solderability testing. If there are one or more defects, the lot shall be considered to have failed.

4.6.1.2.6.2 Rejected lots. In the event of one or more defects, the inspection lot shall be rejected. The manufacturer may use one of the following options to rework the lot:

- a. Each production lot that was used to form the failed inspection lot shall be individually submitted to the solderability test as required in 4.6.1.2.6.1. Production lots failing the solderability test can be reworked only if submitted to the reprocessing procedure in 4.6.1.2.6.2b.
- b. The manufacturer shall submit the failed production lot to 100 percent reprocessing of the terminations, using a process approved by the qualifying activity. Following the reprocessing, the electrical measurements required in the group A, subgroup 1 test shall be repeated on 100 percent of the lot. The PDA for electrical measurements shall be as for the subgroup 1 tests. Thirteen additional samples shall then be selected and subjected to the solderability test with no defects allowed. If the lot fails this solderability test, the lot shall be considered rejected and shall not be furnished against the requirements of this specification.

4.6.1.2.6.3 Disposition of samples. The solderability test is considered a destructive test and samples submitted to the solderability test shall not be supplied on the contract.

4.6.1.2.7 PPM calculations. The manufacturer shall establish a ppm system in accordance with 3.3.2 for assessing and calculating average outgoing quality of capacitors. A ppm rate combining capacitance, DF, IR (25°C), and DWV shall be assessed for lots that have passed the group A inspection. The manufacturer's ppm system shall also address rectification procedures for lots failing ppm assessment. Data from the rectification process shall not be used to calculate ppm.

4.7 Periodic group C inspection (ER only). Periodic inspection shall consist of the group C inspection tests specified in table XI, in the order shown. Group C inspection shall be performed on sample units randomly selected from inspection lots which have passed group A inspection. Except where the results of periodic inspection show noncompliance with the applicable requirements (see 4.7.2), delivery of products which have passed group A inspection shall not be delayed pending the results of this periodic inspection.



## MIL-PRF-55681F

4.7.1 Sampling plan.

4.7.1.1 Subgroup 1, subgroup 2, and subgroup 5 (all FR levels). Thirty-six sample units of each voltage-temperature characteristic shall be selected from the first inspection lot produced every 6 months.

4.7.1.2 Subgroup 3 (all FR levels). A minimum of 25 sample units per style of the highest capacitance value produced shall be selected from the first inspection lot produced during a 6-month period. Permitted failures shall be as specified in MIL-STD-690. The accumulated data shall be used for maintenance and extension of FR qualification.

4.7.1.3 Subgroup 4 (all FR levels) (high frequency only). Twelve sample units of each voltage-temperature characteristic shall be selected from the first lot produced.

4.7.1.4 Disposition of sample units. Sample units which have been subjected to group C inspection shall not be delivered on the contract or order.

4.7.2 Noncompliance. If a sample fails to pass group C inspection, the manufacturer shall notify the qualifying activity and cognizant inspection activity of such failure and take corrective action on the materials or processes, or both, as warranted, and on all units of product which can be corrected and which were manufactured under essentially the same conditions, with essentially the same materials and processes, and which are considered subject to the same failure. Acceptance and shipment of the product shall be discontinued until corrective action, acceptable to the qualifying activity has been taken. After the corrective action has been taken, group C inspection shall be repeated on additional sample units (all inspection, or the inspection which the original sample failed, at the option of the qualifying activity). Group A inspection may be reinstated; however, final acceptance and shipment shall be withheld until the group C inspection has shown that the corrective action was successful.

TABLE XI. Group C inspection.

Inspection	Requirement paragraph	Test method paragraph	Number of sample units to be inspected	Number of defectives permitted
<u>Subgroup 1</u> Temperature coefficient and capacitance drift Voltage-temperature limits <u>1/ 2/</u> Thermal shock and immersion <u>3/</u>	3.23 3.14 3.15	4.8.20 4.8.11 4.8.12	12	0
<u>Subgroup 2</u> Resistance to soldering heat Moisture resistance	3.16 3.17	4.8.13 4.8.14	12	0
<u>Subgroup 3</u> Life (at elevated ambient temperature)	3.19	4.8.16	25 minimum	See 4.7.1.2
<u>Subgroup 4</u> Terminal strength (when specified, see 3.1) <u>3/</u> Series resonance (when specified, see 3.1)	3.22 3.21	4.8.19 4.8.18	12	0
<u>Subgroup 5</u> Humidity, steady state, low voltage	3.18	4.8.15	12	0

1/ If the manufacturer can demonstrate that this test has been performed five consecutive times with zero failures, the frequency of this test, with the approval of the qualifying activity, can be performed on an annual basis. If the design, material, construction or processing of the part is changed or, if there are any quality problems or failures, the qualifying activity may require resumption of the original test frequency.

2/ Not applicable to high frequency capacitors.

3/ If the manufacturer can demonstrate that this test has been performed five consecutive times with zero failures, this test, with the approval of the qualifying activity, can be deleted. The manufacturer, however, shall perform this test every three years after the deletion as part of long term design verification. If the design, material, construction or processing of the part is changed or, if there are any quality problems, the qualifying activity may require resumption of the specified testing. Deletion of testing does not relieve the manufacturer from meeting the test requirement in case of dispute.

## MIL-PRF-55681F

4.8 Methods of inspection.

4.8.1 Mounting for testing. When specified in the test procedures, the chip capacitors shall be mounted on a suitable substrate (e.g., 96 percent alumina or FR4 glass epoxy). The substrate and mounting process shall be such that it will not be the cause of, nor contribute to, failure of any test for which it may be used. The capacitors shall be mounted on the substrate as follows:

- a. A substrate shall be prepared with metallized surface land areas of proper spacing to permit mounting of chips by soldering the terminations of the chips to the substrate land areas. The dimensions of the test card are optional.
- \* b. Solder paste, type Sn60A, Pb36B, or Sn63A in accordance with J-STD-005 and J-STD-006, shall be used.
- c. The chip capacitor shall be soldered to the substrate using a solder reflow process. Conductive belt reflow and IR reflow processes are suggested. The temperature range of the peak reflow temperature shall be between 220°C and 260°C. Recommended ramp rates during preheating should not exceed 4°C per second. The substrates and capacitors shall be allowed to cool at room temperature.
- d. The substrate shall be cleaned to remove flux residue, if applicable. Any residue which degrades capacitor electrical performance shall be removed.

4.8.1.1 Test rack. When specified, the substrate shall be mounted on a test rack that shall be so designed as to permit readout for electrical parameters at +25°C and +125°C and to monitor each chip under test for failure. This will insure uniform and uninterrupted voltage and heat stresses.

4.8.2 Visual and mechanical inspection. Capacitors shall be examined to verify that the materials, design, construction, physical dimensions, and workmanship are in accordance with the applicable requirements (see 3.1, 3.4, 3.5, and 3.24 through 3.26).

4.8.3 Voltage conditioning (see 3.6). One of the voltage conditioning tests in 4.8.3.1 or 4.8.3.2 shall be performed. The lot traveler shall indicate which test is used. When the optional voltage conditioning test of 4.8.3.2 is used, the traveler shall include the specific accelerated voltage used and the test time.

4.8.3.1 Standard voltage conditioning. A minimum of twice the rated voltage shall be applied to the unit at the maximum rated temperature +4°C, -0°C for 100 hours +25 hours, -4 hours. After completion of the exposure period, the unit shall be stabilized at room temperature and the DWV (see 3.6a), IR, capacitance, and DF shall be measured as specified in 4.8.9, 4.8.6, 4.8.4, and 4.8.5, respectively. Due to the deaging characteristic of ceramic, capacitance measurement may be delayed (applicable to BR, BX, and BZ characteristics only).

4.8.3.2 Optional voltage conditioning (capacitors with voltage ratings of 200 volts or less only). The manufacturer, with approval from the qualifying activity, may perform an optional voltage conditioning test instead of the standard voltage conditioning test of 4.8.3.1. All conditions of 4.8.3.1 apply, with the exception of the voltage applied and the test time. The minimum time duration, T(test), shall be calculated as follows:

$$T_{\text{test}} \text{ (min)} = \frac{800}{(E_{\text{test}} / E_{\text{rated}})^3}$$

Where:  $2 \times E_{\text{rated}} \leq E_{\text{test}} \leq 4 \times E_{\text{rated}}$

$T_{\text{test}}$  = Minimum test time in hours

$E_{\text{test}}$  = Applied voltage

$E_{\text{rated}}$  = Rated voltage of the capacitor

## MIL-PRF-55681F

4.8.4 Capacitance (see 3.7) (for high frequency styles, see 3.1). Capacitors shall be tested in accordance with method 305 of MIL-STD-202. The following details and exception shall apply:

- a. Test frequency: 1 MHz  $\pm$ 50 kHz (for all BP and BG characteristic capacitors  $\leq$  1,000 pF, and for all BX characteristic capacitors  $\leq$  100 pF); or 1 kHz  $\pm$ 50 Hz for all other capacitors.
- b. Test voltage: 1.0 volt  $\pm$ 0.2 volt rms.

Stable capacitance standards may be used, at the option of the manufacturer, to eliminate or reduce capacitance bridge and fixturing error when measuring capacitance of less than 100 pF. The method used for making these measurements shall be included in the manufacturer's program plan in accordance with MIL-STD-790.

4.8.5 DF (see 3.8). DF shall be measured with a bridge or other suitable equipment at the frequency and voltage specified in 4.8.4.

4.8.6 IR (see 3.9). Capacitors shall be tested in accordance with method 302 of MIL-STD-202. The following details shall apply:

Precautionary note: Prior to performing this test, capacitors shall be carefully cleaned to remove any contamination including fingerprints. Care must be taken to maintain cleanliness in test chamber and while making measurements.

- a. Test conditions: Rated voltage as specified (see 3.1) applied through a series resistor sufficient to limit the charging current to a maximum of 50 milliamperes (mA).
- b. Special conditions: If a failure occurs at a relative humidity above 50 percent, the IR may be measured again at any relative humidity less than 50 percent.
- c. Points of measurement: Between the terminations (metallized ends) or leads.

4.8.7 ESR (UHF) (when specified, see 3.1) (see 3.10). The UHF ESR shall be measured in accordance with appendix A and table XII. Leaded devices shall be characterized as having the same ESR as equivalent nonleaded devices manufactured from the same dielectric/metallization material lot.

TABLE XII. ESR (UHF) test frequency range.

Capacitance range	Frequency range	Wavelength
100 pF or less	910 MHz - 1,050 MHz	7/4
101 pF - 330 pF	640 MHz - 660 MHz	5/4
331 pF - 1,000 pF	380 MHz - 400 MHz	3/4

4.8.8 ESR (RF) (when specified, see 3.1) (see 3.11). The RF ESR shall be measured in accordance with appendix A at one-quarter wavelength in a frequency range of 130 MHz to 260 MHz. Leaded devices shall be characterized as having the same ESR as equivalent nonleaded devices manufactured from the same dielectric/metallization material lot.

4.8.9 DWV (see 3.12). Unmounted capacitors shall be tested in accordance with method 301 of MIL-STD-202. The following details and exceptions shall apply:

- a. Magnitude and nature of test voltage: Unless otherwise specified (see 3.1), 250 percent of rated voltage.
- b. Duration of application of test voltage: 5 seconds  $\pm$ 1 second.
- c. Points of application of test voltage: Unless otherwise specified (see 3.1), between the capacitor-element terminals.
- d. Limiting value of surge current: Shall not exceed 50 mA.

## MIL-PRF-55681F

e. Examination after test: Capacitors shall be examined for evidence of damage and breakdown.

4.8.10 Solderability (see 3.13). Capacitors shall be tested in accordance with method 208 of MIL-STD-202. The following details and exceptions shall apply:

- a. For capacitors without leads, each terminal shall be immersed to a depth of .020 inch +.010 inch, -.000 inch (0.51 mm +0.25 mm, -0.00 mm), or the entire capacitor may be immersed.
- b. For capacitors with leads, each terminal shall be immersed to a distance of .030 inch  $\pm$ .020 inch (0.76 mm  $\pm$ 0.51 mm) to the capacitor body.
- c. Examination of terminations shall be in accordance with 3.13. In case of dispute, the percent coverage with pinholes or rough spots shall be determined by actual measurement of these areas, as compared to the total area.

4.8.11 Voltage-temperature limits (not applicable to high frequency capacitors)(see 3.14). The temperature of each capacitor shall be varied as specified in table XIII. Capacitance measurements shall be made at the frequency specified in 4.8.4. The dc rated voltage need only be applied to the capacitor in each of step E through step G until voltage stability is reached and the capacitance measurement made. Capacitance measurements shall be made at each step specified in table XIII and at a sufficient number of intermediate points between step B and step G to establish a true characteristic curve. Capacitance measurements at each temperature shall be taken at five-minute intervals and shall be stopped and recorded when two successive readings indicate a capacitance change of less than one percent. These measurements need be performed only on capacitors having a value of 10 pF or greater. Capacitors of less than 10 pF shall be characterized as having the same voltage-temperature limits as those of 10 pF or more manufactured from the same dielectric material lot. For voltage ratings above 200 V, an approved alternate test method based on volts/mil stress of the same dielectric lot is allowed.

TABLE XIII. Voltage-temperature limit cycle.

Step <u>1/</u>	Voltage, dc	Temperature, °C
A	None	+25 $\pm$ 2
B	None	-55 $\pm$ 2
C <u>2/</u>	None	+25 $\pm$ 2
D	None	+125 +4, -0
E	Rated (see 3.1)	+125 +4, -0
F	Rated (see 3.1)	+25 $\pm$ 2
G	Rated (see 3.1)	-55 $\pm$ 2

1/ Step A through step D and step F (without voltage) only for BP and BG characteristics.

2/ Reference.

4.8.12 Thermal shock and immersion (see 3.15).

4.8.12.1 Thermal shock. Capacitors shall be tested in accordance with method 107 of MIL-STD-202. The following details shall apply:

- \*
- a. Test condition: Test condition A, except that in step 3, sample units shall be tested at +125°C.
  - b. Measurements before and after cycling: Not applicable.

## MIL-PRF-55681F

4.8.12.2 Immersion. Following thermal shock, capacitors shall be tested in accordance with method 104 of MIL-STD-202. The following details shall apply:

- a. Test condition: Test condition B.
- b. Examinations and measurements after final cycle: Capacitors shall meet the requirements of 3.15.

4.8.13 Resistance to soldering heat (see 3.16). Capacitors shall be tested in accordance with method 210 of MIL-STD-202. The following details and exceptions shall apply:

- a. Mounting of specimens: The capacitors shall be mounted on a substrate using the methods of 4.8.1, with the following exception: The post preheat hot-plate temperature shall be  $+260^{\circ}\text{C} \pm 5^{\circ}\text{C}$  for a duration of 5 seconds  $\pm 0.5$  second. Tunnel ovens shall not be used to provide the soldering heat, since an observation is recommended during the test.
- \* b. Test condition:       Leaded capacitors: B  
                                  Unleaded capacitors: J, except with only one heat cycle.
- c. Measurements after test: After completion of the cleaning process and following a minimum 10-minute to maximum 24-hour cooling period, the capacitance, DF, and IR shall be measured as specified in 4.8.4, 4.8.5, and 4.8.6, respectively.
- d. Examination after test: Capacitors shall be examined for evidence of mechanical damage.

4.8.14 Moisture resistance (see 3.17). Capacitors shall be tested in accordance with method 106 of MIL-STD-202. The following details and exceptions shall apply:

- a. Initial measurements: Capacitance as specified in 3.7.
- b. Number of cycles: Twenty continuous cycles except that steps 7a and 7b shall be omitted.
- c. Polarizing voltage shall be 50 V dc during the first ten cycles.
- d. Examinations and final measurements: On completion of step 6 of the final cycle, capacitors shall be conditioned at  $25^{\circ}\text{C} \pm 5^{\circ}\text{C}$  and a relative humidity between 30 percent and 60 percent for a period of 18 hours minimum to 24 hours maximum, and shall be visually examined for evidence of mechanical damage and obliteration of marking; capacitance, DWV, and IR shall then be measured as specified in 4.8.4, 4.8.9, and 4.8.6, respectively.

4.8.15 Humidity, steady state, low voltage (see 3.18). Capacitors shall be tested in accordance with method 103 of MIL-STD-202, condition A. The following details and exceptions shall apply:

NOTE: At no time during test shall voltage greater than 1.55 volts be applied to any capacitor under test.

- a. Initial measurements: Capacitance shall be measured in accordance with 4.8.4.
- b. Tests: Capacitors shall be subjected to an environment of  $+85^{\circ}\text{C}$  with 85 percent relative humidity for 240 hours minimum. Cycling shall not be performed. A dc potential of 1.3 volts  $\pm 0.25$  volts shall be applied continuously through a 100 kilohm resistor.
- c. Final measurements: On completion of test, remove the capacitors from the chamber and allow 3 hours, 30 minutes,  $\pm 30$  minutes for drying and stabilization at  $25^{\circ}\text{C}$  before performing IR (through a 100 kilohm resistor at  $1.3 \pm 0.25$  volts) and capacitance in accordance with 4.8.6 and 4.8.4, respectively. The capacitors shall then be examined for evidence of mechanical damage and obliteration of marking.
- d. Leads may be attached to chip capacitors for mounting and loading purposes. Mechanical loading is acceptable.

## MIL-PRF-55681F

4.8.16 Life (at elevated ambient temperature)(see 3.19). Capacitors shall be tested in accordance with method 108 of MIL-STD-202. The following details and exceptions shall apply:

- a. Capacitors shall be mounted as specified in 4.8.1 and 4.8.1.1.
- b. Test temperature and tolerance: At the maximum rated temperature, +125°C +4°C, -0°C.
- c. Operating conditions: Capacitors shall be subjected to a minimum of 200 percent of rated voltage (see 3.1). The surge current shall not exceed 50 mA. When necessary, a suitable current-limiting resistor shall be inserted into the circuit.
- d. Test condition: Test condition F (2,000 hours).
- e. Measurements during and after exposure: After 1,000 hours and at the conclusion of this test and while the capacitors are still held at the maximum rated temperature, IR shall be measured as specified in 4.8.6. The capacitors shall then be returned to the inspection conditions specified in 4.3 and shall be visually examined for evidence of mechanical damage; capacitance, DF, and IR shall be measured as specified in 4.8.4, 4.8.5, and 4.8.6, respectively.
- f. Final measurement: Capacitors shall meet the requirements of 3.19.

4.8.17 Fungus, when applicable (see 3.20). Capacitors shall be tested in accordance with method 508 of MIL-STD-810.

4.8.18 Series resonance (when specified, see 3.1)(see 3.21). Capacitors shall be mounted as specified in 4.8.1 and tested to determine minimum series resonance frequency. Measurement frequency shall be varied smoothly between 100 MHz and 10,000 MHz.

4.8.19 Terminal strength (when specified, see 3.1) (see 3.22). Capacitors shall be tested in accordance with method 211 of MIL-STD-202. The following details and exceptions shall apply:

- a. Test condition: B (five bends).
- b. Examination after test: Visual examination for loosening, rupturing, and permanent damage to the terminals.

4.8.20 Temperature coefficient and capacitance drift (high frequency capacitors only) (see 3.23).

4.8.20.1 Temperature coefficient. Capacitance measurements shall be made as specified in 4.8.4 and at the temperatures specified in table XIII.

4.8.20.2 Capacitance drift. Capacitance drift shall be computed by dividing the greatest single difference between any two of the three capacitance values recorded at 25°C by the value determined at the reference temperature (see table XIII).

## 5. PACKAGING

- \* 5.1 Packaging. For acquisition purposes, the packaging requirements shall be as specified in the contract or order (see 6.2). When packaging of materiel is to be performed by DoD or in-house contractor personnel, these personnel need to contact the responsible packaging activity to ascertain packaging requirements. Packaging requirements are maintained by the Inventory Control Point's packaging activities within the Military Service or Defense Agency, or within the military service's system commands. Packaging data retrieval is available from the managing Military Department's or Defense Agency's automated packaging files, CD-ROM products, or by contacting the responsible packaging activity.

## MIL-PRF-55681F

## 6. NOTES

(This section contains information of a general or explanatory nature that may be helpful, but is not mandatory.)

- \* 6.1 Intended use. Ceramic chip capacitors are intended to be used in thin and thick film hybrid circuits where micro-circuitry is indicated for filter by-pass coupling applications, and where variation in capacitance with respect to temperature (-55°C to +125°C), voltage, frequency, and life can be tolerated. This specification also covers high frequency capacitors (CDR11 through CDR14 and CDR21 through CDR25) that are primarily intended for use in resonant circuits with high Q factor and stability of capacitance with respect to temperature (-55°C to +125°C), frequency, and life. These capacitors also offer established reliability that is verified under a qualification system. Commercial components are not designed to withstand these military environmental conditions.
  - 6.2 Acquisition requirements. Acquisition documents must specify the following:
    - a. Title, number, and date of this specification, the applicable specification sheet, and the complete PIN (see 1.2.1 and 3.1).
    - b. Capacitor marking (see 3.24).
    - c. Packaging requirements.
- \* 6.3 Qualification. With respect to products requiring qualification, awards will be made only for products that are, at the time of award of contract, qualified for inclusion in Qualified Products List whether or not such products have actually been so listed by that date. The attention of the contractors is called to these requirements, and manufacturers are urged to arrange to have the products that they propose to offer to the Federal Government tested for qualification in order that they may be eligible to be awarded contracts or orders for the products covered by this specification. The activity responsible for the Qualified Products List is the U.S. Army Communications-Electronics Command, ATTN: AMSEL-LC-LEO-E-EP, Fort Monmouth, NJ 07703-5023; however, information pertaining to qualification of products may be obtained from the Defense Supply Center, Columbus, ATTN: DSCC-VQP, PO Box 3990, Columbus, OH 43216-5000, or by e-mail to [vqp.chief@dla.mil](mailto:vqp.chief@dla.mil).
  - 6.4 Metallized terminations. It should be noted that when pure silver is used for the termination, silver migration between the terminations may occur under conditions of simultaneous application of high humidity and dc voltage. This produces a troublesome electrical leakage path across the capacitor chip. Addition of about 20 percent of palladium to the silver to form an alloy will retard the tendency toward silver migration. Complete overcoating of the silver termination by the lead-tin bonding solder also will retard the tendency toward silver migration. Addition of about 3 percent of silver to the lead-tin bonding solder will tend to reduce the leaching of silver from the silver termination during the solder bonding operation.
    - 6.4.1 Termination finish N. Solder embrittlement may take place if termination finish N is used with tin-lead solder.
  - \* 6.4.2 Tin plated finishes. Termination finishes that contains 100 percent tin that may result in tin whisker growth. Tin whisker growth can adversely effect the operation of electronic equipment systems. For additional information, see ASTM B545, "Standard Specification for Electrodeposited Coatings of Tin".
- \* 6.5 Wave soldering. 1206 and larger chips are not recommended for wave soldering. Wave soldering uses liquid metal that has the highest heat transfer rate and is the hardest soldering method to use without shocking surface mount components. When extreme thermal shock is present, it is very obvious with visible cracks on the surface and sides of the capacitor. These cracks start at or near the termination and ceramic interface extending from the termination down along the capacitor edge. These surface cracks can become elliptical or circular shaped in the larger capacitor sizes. The cracks can eventually lead to failure of the capacitors. Some of this information was taken from MIL-PRF-55681 manufacturers Internet sites. The manufacturers should be contacted for further information.

## MIL-PRF-55681F

6.6 Ambient operating conditions. Designers are cautioned to give consideration to the change in dielectric constant with temperature, shelf aging, and electric-field intensity, and should recognize that the IR may vary with humidity and organic contamination of the ceramic chip surfaces. Care should be taken to assure that the capacitors are properly and thoroughly cleansed of organic contamination, especially before the IR test.

6.7 Barometric pressure test. These units are not subject to the barometric pressure test since the likelihood of their failure is remote.

6.8 Effect of mounting on reliability. Voltage-temperature limits and resistance to thermal shock, and reliability may be affected as a result of mounting on substrate with dissimilar coefficients of expansion from capacitor material. Care should be taken in the selection of substrate material.

6.9 Supersession data. Capacitors of this specification are not intended to be used for replacement purposes. Therefore, no interchangeability and substitution data are offered.

6.10 Selection and use information. Equipment designers should refer to MIL-HDBK-198, "Capacitors, Selection and Use of", for a selection of standard capacitor types and values for new equipment design. Additional application and use information concerning these capacitors is also provided in MIL-HDBK-198.

6.11 Supplying for logistic support. Chip components require use of sophisticated equipment to remove from and install on printed wiring boards. Only requisitioners with in-house or contracted capability to replace surface mounted components should be supplied with chip components, in accordance with their specification.

6.12 Marking of comparable MIL-C-11272, non-ER parts. An ER part manufactured in accordance with this specification and MIL-PRF-55681/4 may be marked and furnished as the non-ER version in accordance with MIL-C-11272/16 and MIL-C-11272/17, and correspondingly, parts manufactured in accordance with this specification and MIL-PRF-55681/5 may be marked and furnished as the non-ER version in accordance with MIL-C-11272/18, if produced on the same assembly line or lines, and provided it is subjected to and meets all the inspection requirements of the ER part.

6.13 Subject term (key word) listing.

Part per million (ppm)  
Statistical process control (SPC)

\* 6.14 Environmentally preferable material. Environmentally preferable materials should be used to the maximum extent possible to meet the requirements of this specification. Table XIV lists the Environmental Protection Agency (EPA) top seventeen hazardous materials targeted for major usage reduction. Use of these materials should be minimized or eliminated unless needed to meet the requirements specified herein (see section 3).

\* Table XIV. EPA top seventeen hazardous materials.

Benzene	Dichloromethane	Tetrachloroethylene
Cadmium and Compounds	Lead and Compounds	Toluene
Carbon Tetrachloride	Mercury and Compounds	1,1,1 - Trichloroethane
Chloroform	Methyl Ethyl Ketone	Trichloroethylene
Chromium and Compounds	Methyl Isobutyl Ketone	Xylene
Cyanide and Compounds	Nickel and Compounds	

6.15 Changes from previous issue. The margins of this specification are marked with asterisks to indicate where changes from the previous issue were made. This was done as a convenience only and the Government assumes no liability whatsoever for any inaccuracies in these notations. Bidders and contractors are cautioned to evaluate the requirements of this document based on the entire content irrespective of the marginal notations and relationship to the last previous issue.



MIL-PRF-55681F

APPENDIX A

EQUIVALENT SERIES RESISTANCE MEASUREMENT CRITERIA  
FOR HIGH FREQUENCY CAPACITOR STYLES CDR11 THROUGH CDR14  
AND CDR21 THROUGH CDR25

A.1 SCOPE

A.1.1 Scope. This appendix specifies the method to determine high frequency loss as measured by equivalent series resistance (ESR). This appendix is a mandatory part of the specification. The information contained herein is intended for compliance.

A.2 APPLICABLE DOCUMENTS

A.2.1 Other publications. The following document forms a part of the specification to the extent specified herein.

ELECTRONIC INDUSTRIES ASSOCIATION

EIA-483 - Standard Method of Test for Effective Series Resistance.

\* (Copies of these documents are available from <http://global.ihs.com> or Global Engineering Documents, Attn: Customer Service Department, 15 Inverness Way East, Englewood CO 80112-5776.)

A.3 PROCEDURES FOR TEST

A.3.1 ESR. When specified, the ESR shall be measured in accordance with EIA-483.

A.4 TEST CRITERIA

A.4.1 ESR. When ESR is tested in accordance with A.3.1, ESR shall be less than the limits shown on figure A-1 through figure A-4 at the specified measurement frequency range.

MIL-PRF-55681F

APPENDIX A

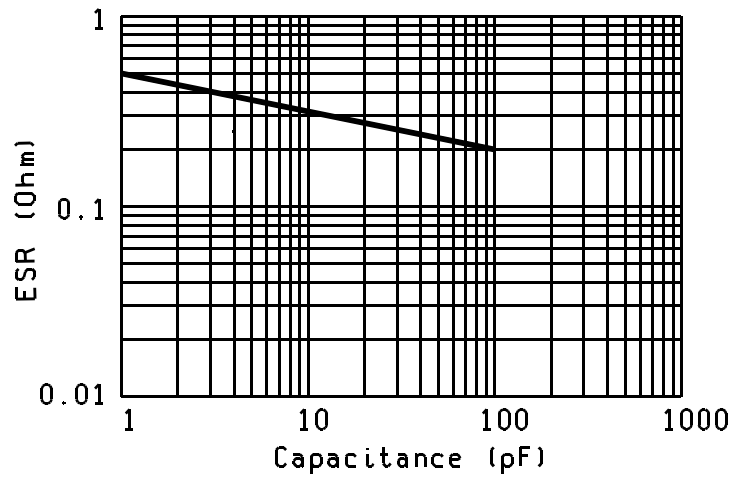

CDR 11/12

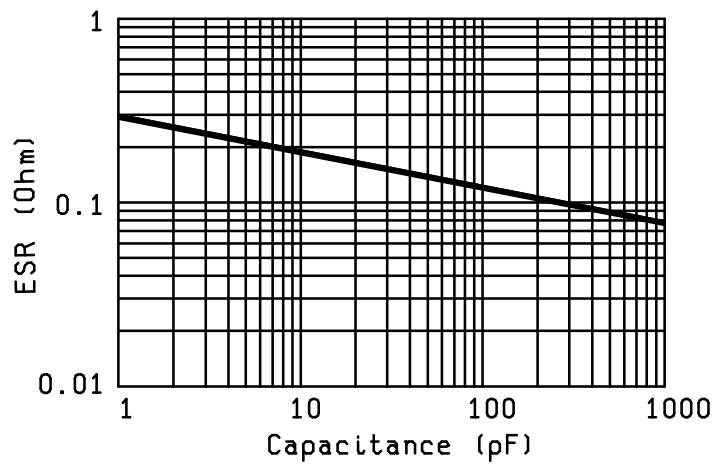

CDR 13/14 AND  
CDR21 THROUGH CDR25

FIGURE A-1. ESR (UHF) (BG characteristic).

MIL-PRF-55681F

APPENDIX A

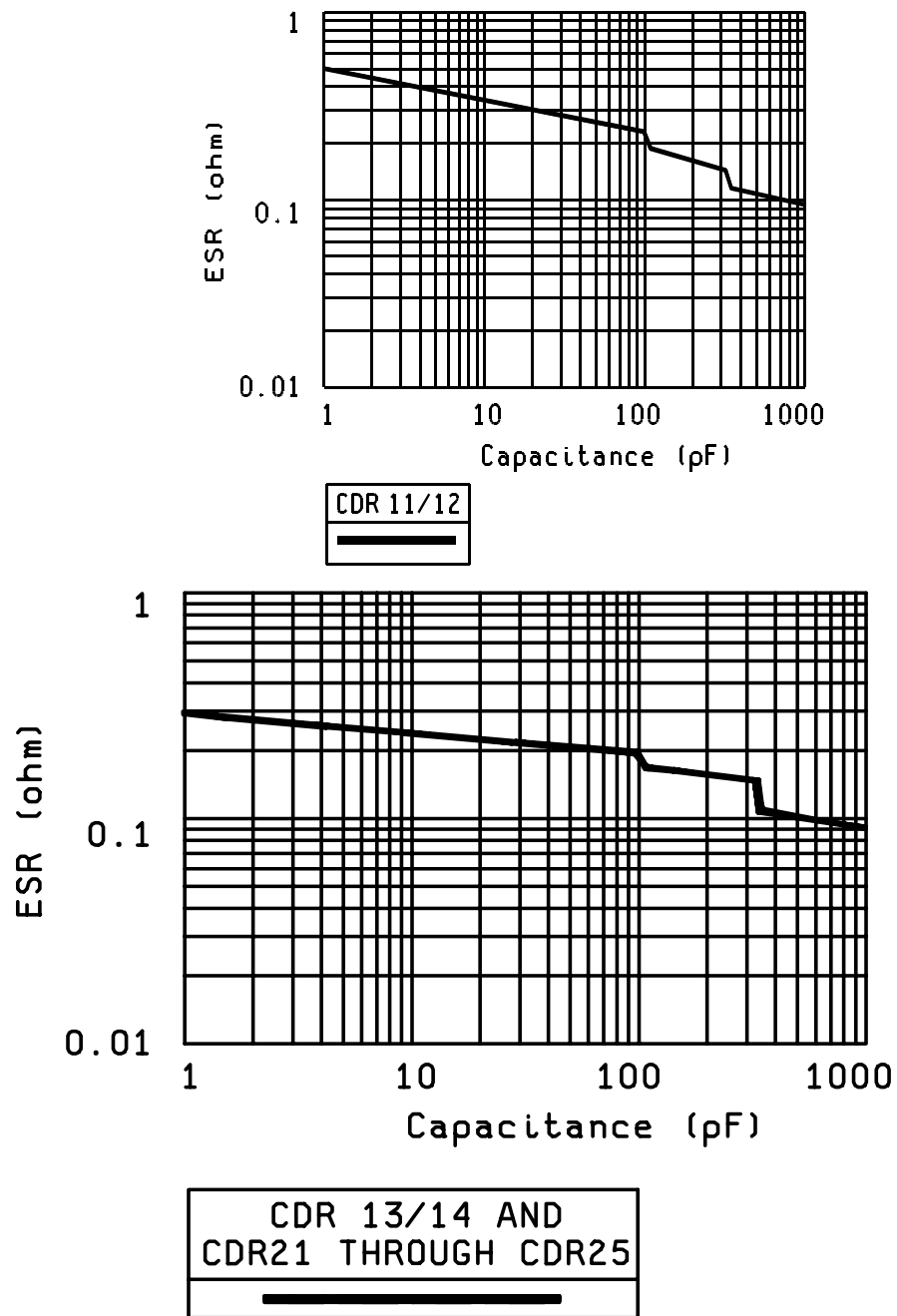

FIGURE A-2. ESR (UHF) (BP characteristic).

MIL-PRF-55681F

APPENDIX A

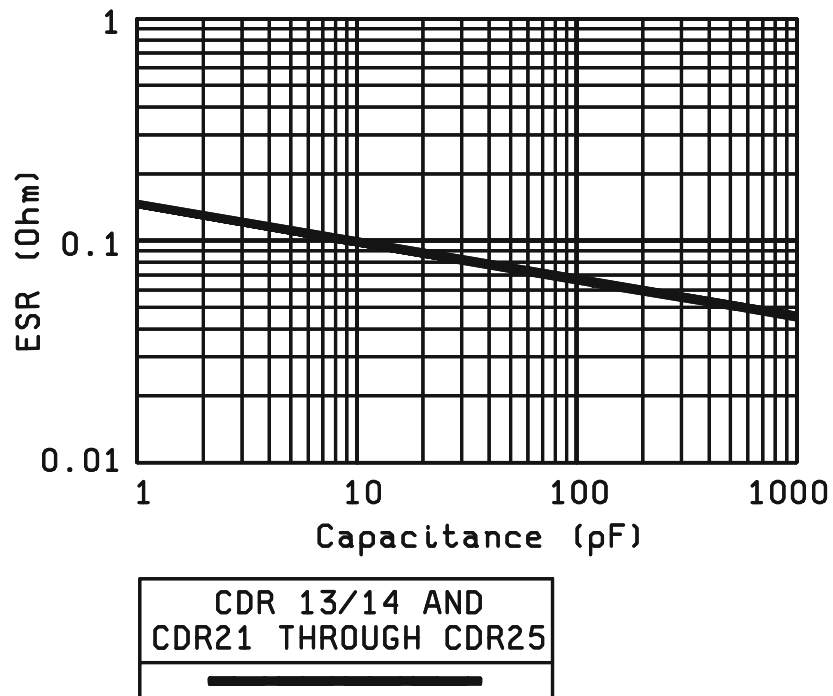
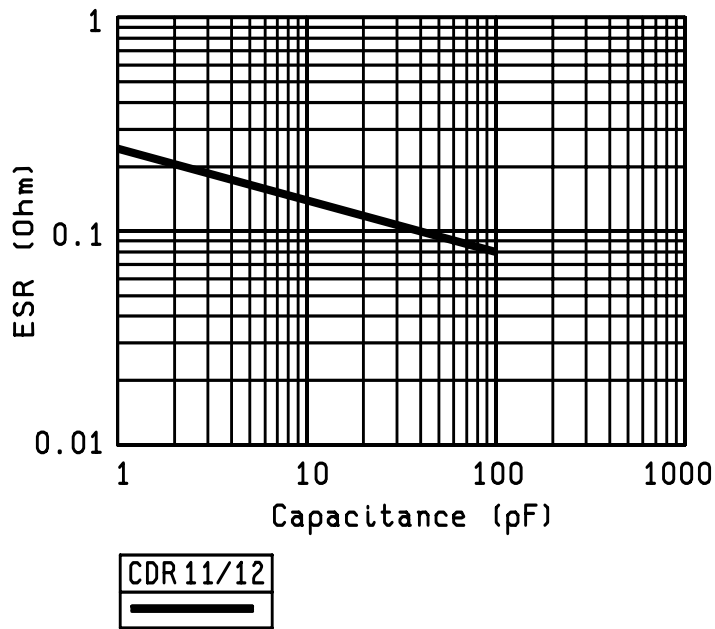

FIGURE A-3. ESR (RF) (BG characteristic).

MIL-PRF-55681F

APPENDIX A

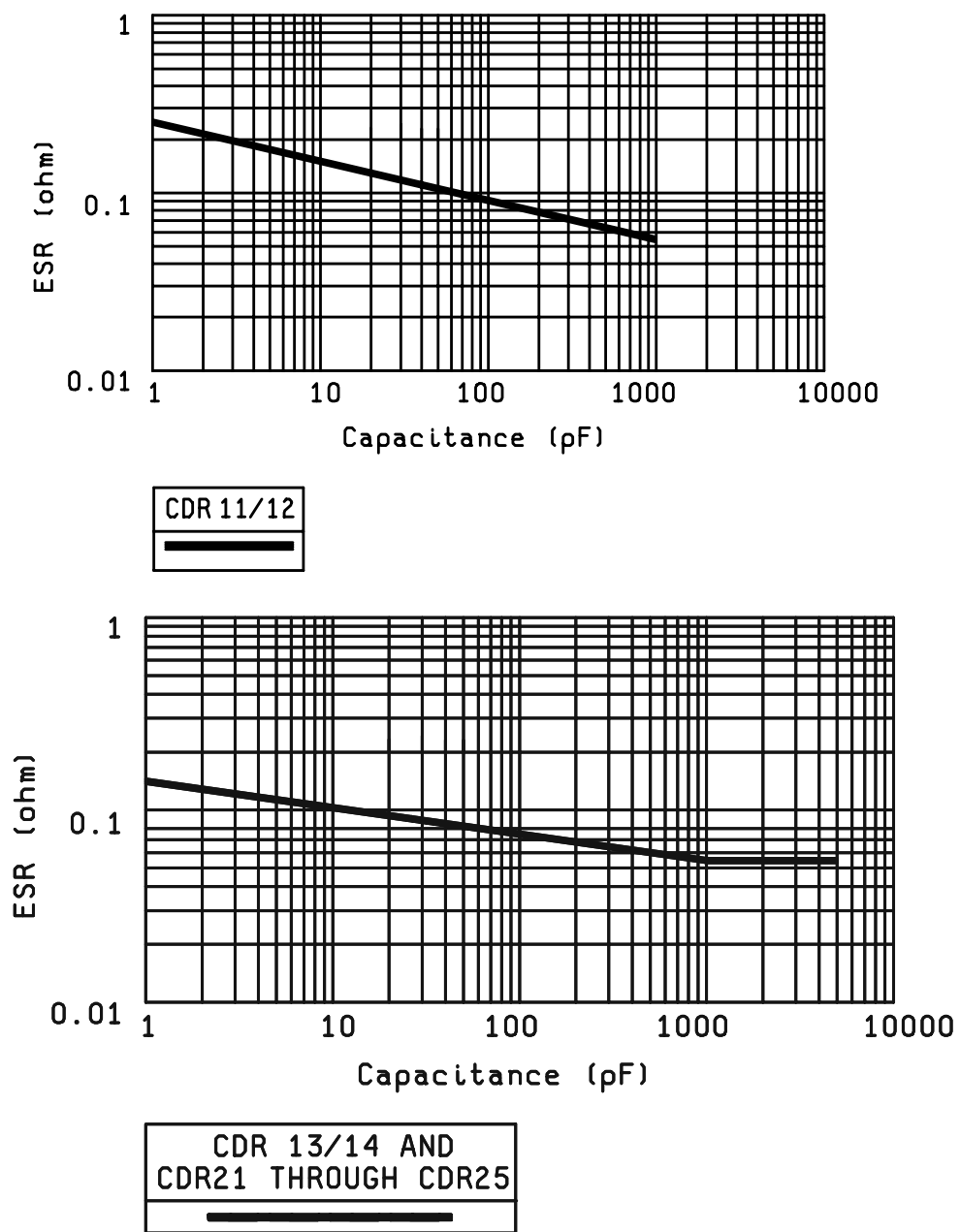

FIGURE A-4. Equivalent series resistance (RF) (BP characteristic)

MIL-PRF-55681F

APPENDIX B

PROCEDURE FOR QUALIFICATION INSPECTION

B.1 SCOPE

B.1.1 Scope. This appendix details the procedure for submission of samples for qualification inspection of capacitors covered by this specification. The procedure for extending qualification of the required sample to other capacitors covered by this specification is also outlined herein. This appendix is a mandatory part of the specification. The information contained herein is intended for compliance.

B.2 APPLICABLE DOCUMENTS. This section is not applicable to this appendix.

B.3 SUBMISSION

B.3.1 Sample.

B.3.1.1 Single-style submission. A sample consisting of 103 sample units of the highest capacitance value in each voltage rating, in each rated temperature and voltage-temperature limits, in each style for which qualification is sought shall be submitted. After qualification has been granted, no changes shall be made in materials, design, or construction without prior notification of the qualifying activity.

B.3.1.2 Combined-voltage submission. A sample consisting of sample units of the highest capacitance value in each voltage rating, in each rated temperature and voltage-temperature limits, in each style for which qualification is sought shall be submitted (see table B-1). After qualification has been granted, no changes shall be made in materials, design, or construction without prior notification of the qualifying activity.

B.4 EXTENT OF QUALIFICATION

B.4.1 Single-style submission. Capacitance-range qualification will be restricted to values equal to and less than the capacitance value submitted. Capacitance-tolerance qualification will be restricted to tolerances equal to and wider than the tolerance submitted. Voltage rating qualification will be restricted to that submitted. Rated temperature and voltage-temperature limit qualification will be restricted to that submitted.

B.4.2 Combined-voltage submission. Capacitance-range qualification will be restricted to values equal to and less than the capacitance value submitted. Capacitance-tolerance qualification will be restricted to tolerances equal to and wider than the tolerance submitted. Voltage rating qualification will be restricted to those submitted.

B.4.3 Product levels. Qualification of the C (non-ER) level is predicated upon meeting the qualification requirements for ER FRL "P". Since the non-ER (C level) is the ER design without the mandatory conformance inspection and FRL assessment, this product is still expected to meet the environmental requirements (e.g., moisture resistance, thermal shock, shock, etc).

## MIL-PRF-55681F

## APPENDIX B

TABLE B-I. Combined-voltage submission.

Style	PIN	Number of units <u>1/</u>	Rated voltage
CDR01	BP181BJ-M	85	100
	BX332BK-M	<u>2/</u> 43	100
	BX472AK-M	<u>2/</u> 43	50
CDR02	BX271BJ-M	85	100
	BX103BK-M	<u>2/</u> 43	100
	BX223AK-M	<u>2/</u> 43	50
CDR03	BP102BJ-M	85	100
	BX333BK-M	<u>2/</u> 43	100
	BX683AK-M	<u>2/</u> 43	50
CDR04	BP332BJ-M	85	100
	BX563BK-M	<u>2/</u> 43	100
	BX184AK-M	<u>2/</u> 43	50
CDR05	BP562BJ-M	85	100
	BX154BK-M	<u>2/</u> 43	100
	BX334AK-M	<u>2/</u> 43	50
CDR06	BP103BJ-M	85	100
	BX474AK-M	85	50
CDR11 and CDR12	B -101K--M <u>3/</u>	43	150
	BP102A--M	43	50
CDR13 and CDR14	B -101E--M <u>3/</u>	85	500
	B -201D--M <u>3/</u>	<u>2/</u> 43	300
	B -471C--M <u>3/</u>	<u>2/</u> 43	200
	B -621B--M <u>3/</u>	<u>2/</u> 43	100
	B -102A--M <u>3/</u>	<u>2/</u> 43	50
	BP512A--M	<u>2/</u> 43	50
CDR21 and CDR22	B -101E-TM <u>3/</u>	85	500
	B -201D-TM <u>3/</u>	<u>2/</u> 43	300
	B -471C-TM <u>3/</u>	<u>2/</u> 43	200
	B -621B-TM <u>3/</u>	<u>2/</u> 43	100
	B -102A-TM <u>3/</u>	<u>2/</u> 43	50
	BP512A-TM	<u>2/</u> 43	50
CDR23 and CDR24	B -101E--M <u>3/</u>	85	500
	B -201D--M <u>3/</u>	<u>2/</u> 43	300
	B -471C--M <u>3/</u>	<u>2/</u> 43	200
	B -621B--M <u>3/</u>	<u>2/</u> 43	100
	B -102A--M <u>3/</u>	<u>2/</u> 43	50
	BP512A--M	<u>2/</u> 43	50
CDR25	B -101E-SM <u>3/</u>	85	500
	B -201D-SM <u>3/</u>	<u>2/</u> 43	300
	B -471C-SM <u>3/</u>	<u>2/</u> 43	200
	B -621B-SM <u>3/</u>	<u>2/</u> 43	100
	B -102A-SM <u>3/</u>	<u>2/</u> 43	50
	BP512A-SM <u>3/</u>	<u>2/</u> 43	50

See footnotes at end of table.

## MIL-PRF-55681F

## APPENDIX B

TABLE B-I. Combined-voltage submission - Continued.

Style	PIN	Number of units <u>1/</u>	Rated voltage
CDR31	BP471BF-M	<u>4/</u> 40	100
	BP681AF-M	<u>4/</u> 40	50
	BX472BK-M	<u>4/</u> 40	100
	BX183AK-M	<u>4/</u> 40	50
CDR32	BP102BF-M	<u>4/</u> 40	100
	BP222AF-M	<u>4/</u> 40	50
	BX153BK-M	<u>4/</u> 40	100
	BX393AK-M	<u>4/</u> 40	50
CDR33	BP222BF-M	<u>4/</u> 40	100
	BP332AF-M	<u>4/</u> 40	50
	BX273BK-M	<u>4/</u> 40	100
	BX104AK-M	<u>4/</u> 40	50
CDR34	BP472BF-M	<u>4/</u> 40	100
	BP103AF-M	<u>4/</u> 40	50
	BX563BK-M	<u>4/</u> 40	100
	BX184AK-M	<u>4/</u> 40	50
CDR35	BP103BF-M	<u>4/</u> 40	100
	BP223AF-M	<u>4/</u> 40	50
	BX154BK-M	<u>4/</u> 40	100
	BX474AK-M	<u>4/</u> 40	50

1/ Number of samples may vary with style (see table VIII). The number of units shown shall be submitted for each termination finish.

2/ Table VIII, group V samples may be split 12-13 or 13-12.

3/ The PIN will include either a letter P or G (see 1.2.1).

4/ The number 40 is derived from the qualification inspection table: 85 total, minus 6 (for fungus test) divided by 2 and rounded off to 40.



MIL-PRF-55681F

APPENDIX C

VISUAL INSPECTION CRITERIA

\*

C.1. SCOPE

C.1.1 Scope. This appendix specifies the visual inspection criteria. This appendix is a mandatory part of the specification. The information contained herein is intended for compliance.

C.2. APPLICABLE DOCUMENTS. This section is not applicable to this appendix.

C.3. PROCEDURES FOR INSPECTION AND REJECTION

C.3.1 Method of inspection. Each device shall be examined under 20X to 40X magnification to determine compliance with the requirements specified herein.

C.3.2 Rejection criteria. Devices that deviate from the material, design or construction requirements specified, or that fail to meet the following requirements, shall be unacceptable.

C.3.2.1 Termination metallization.

- a. End terminals shall be completely covered. Pinholes less than or equal to .005 inch (0.13 mm) in diameter are permitted (maximum of three pinholes in each surface area).
- b. Gaps in the metallization band shall only be acceptable if the metallization band is not less than the minimum metallization band requirement specified (see figure C-1).
- c. Metallized edges shall not be reduced to less than 90 percent due to chipping or metallizing process (see figure C-2).
- d. There shall be no excess metallization or solder tear which violates the minimum pad separation (see figure C-3).
- e. There shall be no foreign material visible adhering to the solder, or voids in the solder revealing greater than 10 percent of the base metallization (see figure C-4).

MIL-PRF-55681F

APPENDIX C

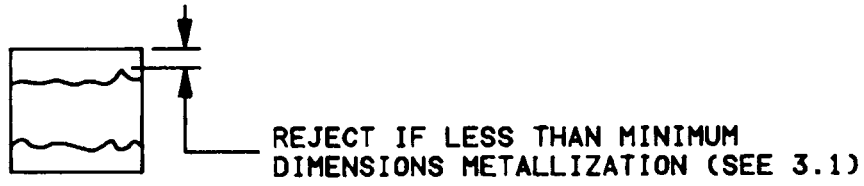

FIGURE C-1. Metallization band gaps.

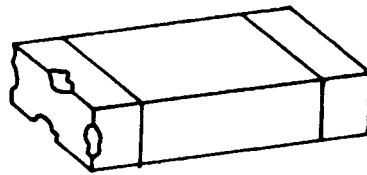

FIGURE C-2. Metallization band chipping.

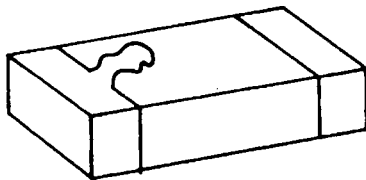

FIGURE C-3. Excessive metallization

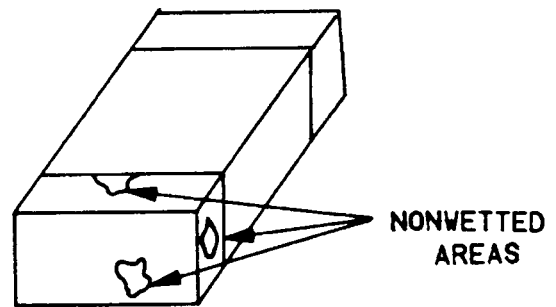

FIGURE C-4. Solder defects.

MIL-PRF-55681F

APPENDIX C

C.3.2.2 Ceramic surface examination.

- a. There shall be no cracks (see figure C-5).
- b. There shall be no delamination of ceramic layers. A delamination is the separation of ceramic layers (usually observed on sides). (see figure C-6.)
- c. Striations are unacceptable (see figure C-6).
- d. Edge chip-outs shall not be greater in depth than .003 inch (0.08 mm) with respect to either plane. An edge chip-out is any region where material has been removed as a result of a fracture (see figure C-7).
- e. Rough edges shall be permitted provided they are within the allowable chip-out region as specified on figure C-7.
- f. Lips, flared edges, or irregular shapes shall not exceed limits specified on figure C-8.
- g. There shall be no fused dust or excess material on external surface that prevents a chip from lying flat, or protrude more than .003 inch (0.08 mm) out of a surface.
- h. There shall be no raised surfaces, bubbles, or blisters greater than .002 inch (0.05 mm) (usually found on top and bottom). (see figure C-9.)
- i. When compared to a flat surface, the clearance (warpage) at the center of the chip shall be less than 5 percent of the length dimension (see figure C-10).
- j. A pinhole is a circular hollow or cavity no larger than .002 inch (0.05 mm) in diameter (see figure C-11). They are unacceptable if they exceed this size.
- k. There shall be no holes (voids) that expose electrode plates (see figure C-12).
- l. The marking (when specified) shall be legible and complete (see figure C-13).

MIL-PRF-55681F

APPENDIX C

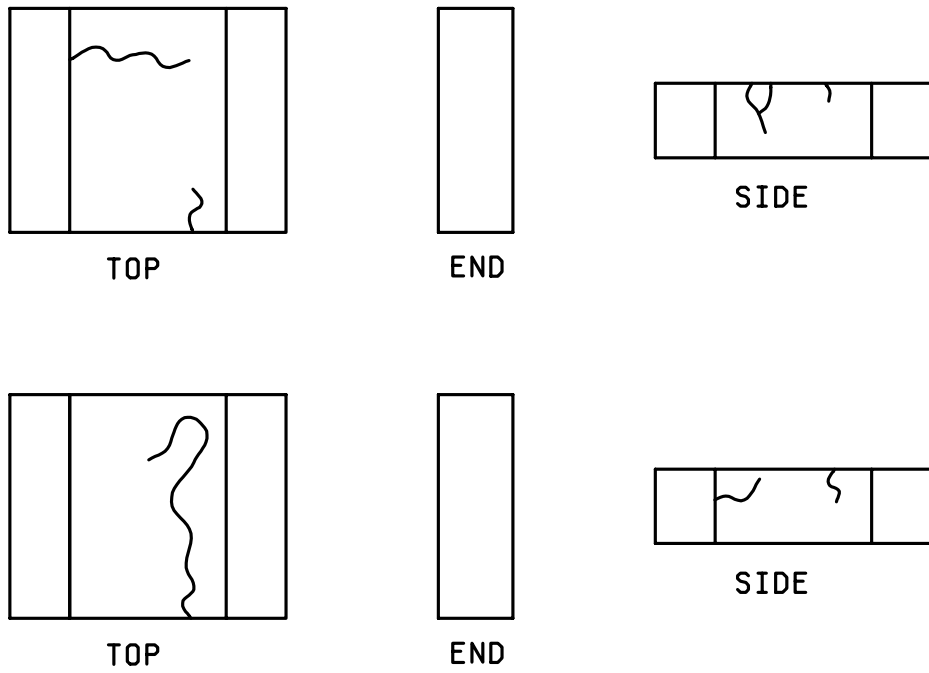

FIGURE C-5. Cracks.

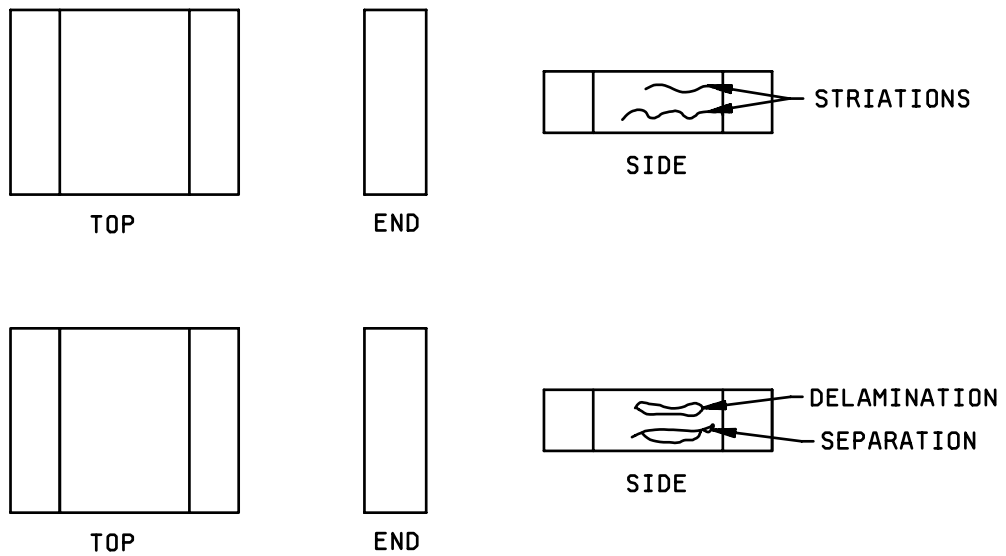

FIGURE C-6. Striations and delaminations.

MIL-PRF-55681F

APPENDIX C

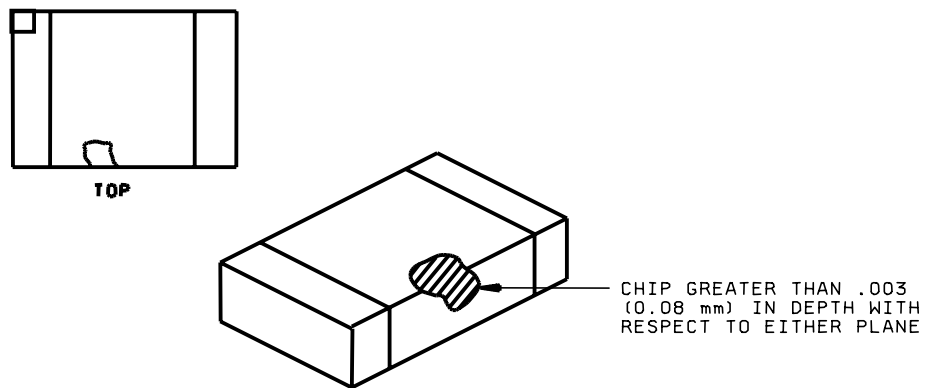

FIGURE C-7. Chip-outs.

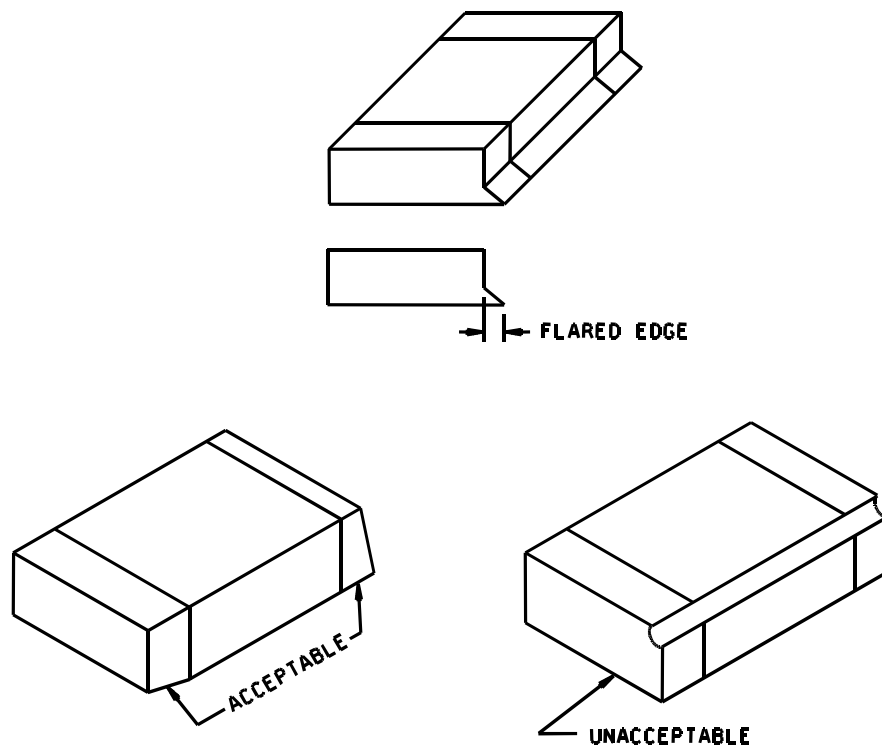

FIGURE C-8. Unacceptable lips, flared edges, or irregular shapes.

MIL-PRF-55681F

APPENDIX C

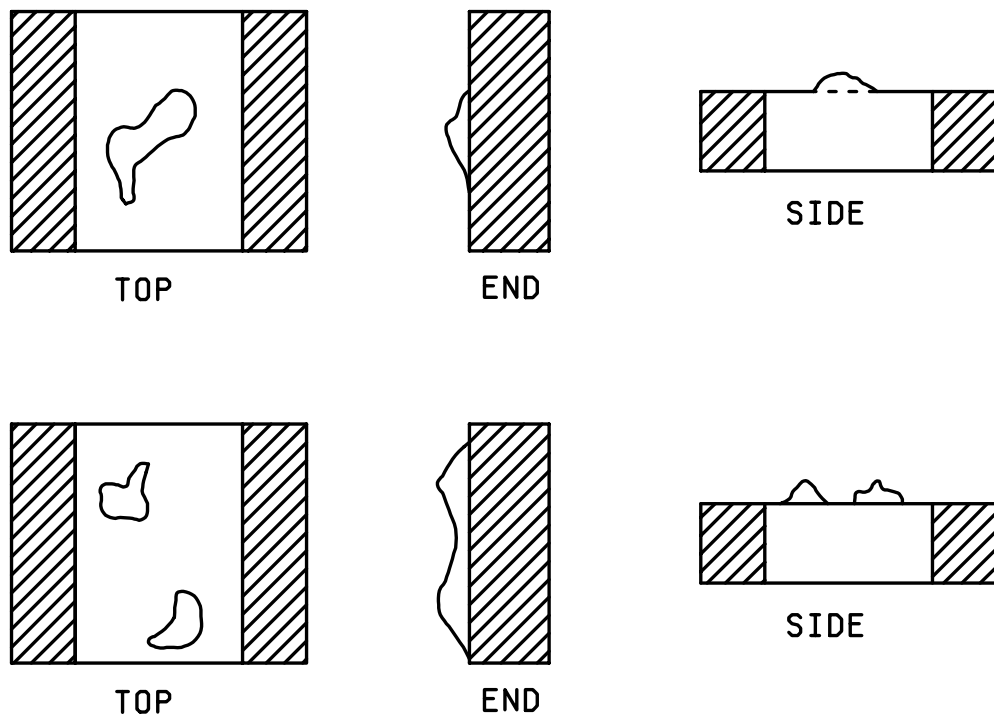

FIGURE C-9. Raised surfaces, bubbles, and blisters.

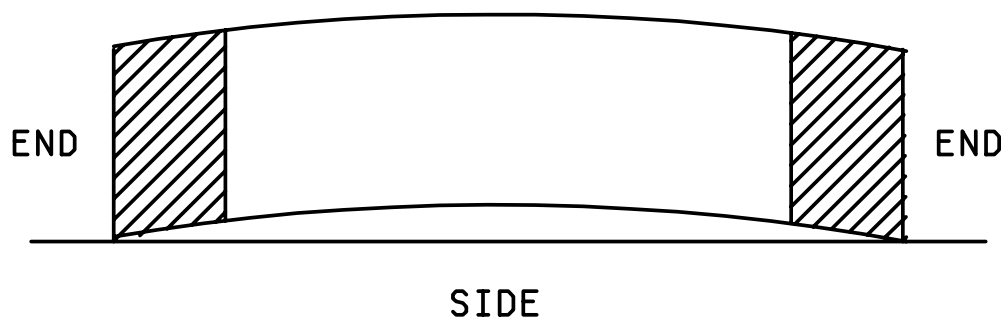

FIGURE C-10. Warpage.

MIL-PRF-55681F

APPENDIX C



FIGURE C-11. Pinholes.

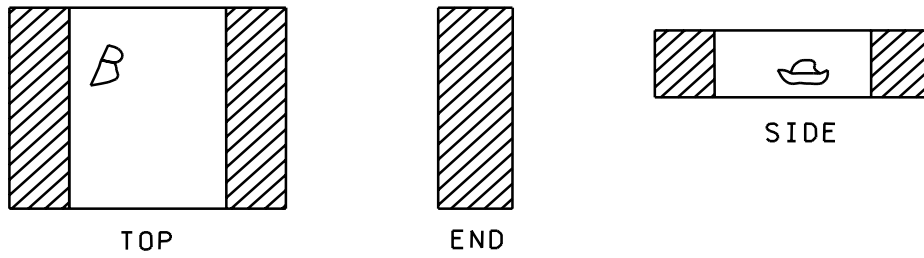

FIGURE C-12. Voids.

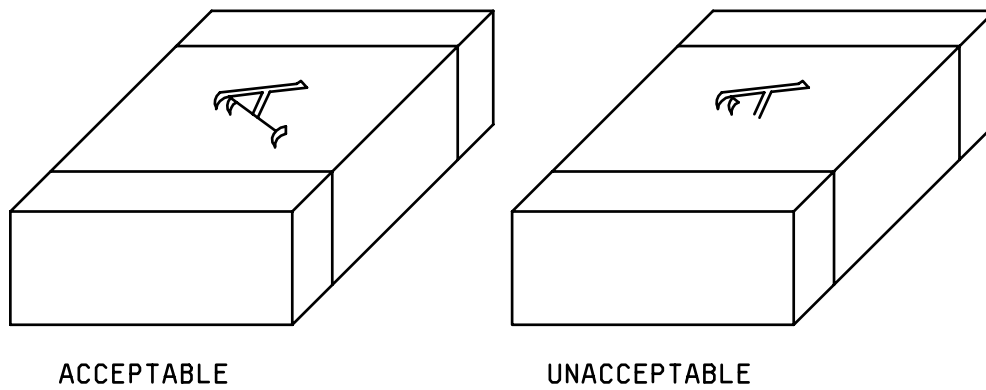

FIGURE C-13. Marking.

MIL-PRF-55681F

Custodians:

Army - CR  
Navy - EC  
Air Force - 11  
DLA - CC

Preparing activity:

Army - CR

Agent:

DLA - CC

Review activities:

Army - MI  
Navy - AS, MC, OS, SH  
Air Force - 19, 99

(Project 5910-2252)

- \* NOTE: The activities listed above were interested in this document as of the date of this document. Since organizations and responsibilities can change, you should verify the currency of the information above using ASSIST Online database at [www.dodssp.daps.mil](http://www.dodssp.daps.mil).