

INCH-POUND

MIL-PRF-55182G
9 June 1997
SUPERSEDING
MIL-R-55182F
26 January 1990

PERFORMANCE SPECIFICATION

RESISTORS, FIXED, FILM, NONESTABLISHED RELIABILITY, ESTABLISHED RELIABILITY, AND SPACE LEVEL, GENERAL SPECIFICATION FOR

This specification is approved for use by all Departments and Agencies of the Department of Defense.

1. SCOPE

1.1 Scope. This specification covers the general requirements for nonestablished (non-ER), established reliability (ER), and space level hermetically and nonhermetically sealed fixed film resistors that have a high degree of stability with respect to time under severe environmental conditions. ER resistors have failure rates (FR) that are established at 60 percent confidence ranging from 0.001 percent per 1,000 hours to 1.0 percent per 1,000 hours.

1.2 Classification.

1.2.1 Type designation. The type designation will be in the following form, and as specified (see 3.1 and 6.2).

<u>RNR55</u>	<u>C</u>	<u>49R9</u>	<u>F</u>	<u>M</u>
—	—	—	—	—
—	—	—	—	—
Style and termination type (1.2.1.1)	Characteristic (1.2.1.2)	Resistance (1.2.1.3)	Resistance tolerance (1.2.1.4)	Product level designator (1.2.1.5)

1.2.1.1 Style and termination type. The style and termination type is identified by a three letter symbol as indicated in table I and a two-digit number. The letters identify non-ER, ER, or space level, fixed, film, resistors, of a specified terminal type and the number identifies the size of the resistor.

Beneficial comments (recommendations, additions, deletions) and any pertinent data which may be of use in improving this document should be addressed to: US Army Communications-Electronics Command, ATTN: AMSEL-LC-LEO-E-EP, Fort Monmouth, NJ 07703-5023 by using the Standardization Document Proposal (DD Form 1426) appearing at the end of this document or by letter.

MIL-PRF-55182G

TABLE I. Terminal type.

Symbol	Terminal
RNR <u>1/</u>	Solderable
RNC <u>2/</u>	Solderable/weldable (type C31, C32, or C52 <u>3/</u>) of MIL-STD-1276
RNN	Weldable (type N22 of MIL-STD-1276)

1/ Terminal type RNR is inactive for new design when specified with characteristics H, J, and K only. Terminal RNR remains active for Characteristics C and E. (see 6.5).

2/ Terminal type RNC is inactive for new design when specified with characteristics C and E only. Terminal RNC remains active for Characteristics H, J, and K. (see 6.5).

3/ The maximum thickness of 200 microinches is not applicable.

1.2.1.2 Characteristic. The characteristic is identified by a single letter in accordance with table II.

TABLE II. Characteristic.

Hermetically sealed (RNR)	Nonhermetically sealed (RNC)	Resistance temperature characteristics (referenced +25°C)
C	H	±50
E	J	±25
	K	±100

1.2.1.3 Resistance. The nominal resistance expressed in ohms is identified by four digits; the first three digits represent significant figures and the last digit specifies the number of zeros to follow. When the value of resistance is less than 100 ohms, or when fractional values of an ohm are required, the letter "R" will be substituted for one of the significant digits to represent the decimal point. When the letter "R" is used, succeeding digits of the group represent significant figures. The resistance-value designations are shown in table III. Minimum and maximum resistance values will be as specified (see 3.1). The standard values for every decade shall follow the sequence demonstrated for the "10 to 100" decade in table IV. Although resistance tolerance B (see 1.2.1.4) normally requires more than three significant figures to adequately describe the true resistance value, for the purpose of this specification, the nominal value will be three significant figures followed by the fourth digit to signify the number of zeros to follow.

TABLE III. Designation of resistance values.

Designation	Resistance (ohms)
10R0 to 98R8 inclusive	10 to 98.8 inclusive
1000 to 9880 inclusive	100 to 988 inclusive
1001 to 9881 inclusive	1,000 to 9,880 inclusive
1002 to 9882 inclusive	10,000 to 98,800 inclusive
1003 to 9883 inclusive	0.1 megohms to 0.988 megohms, inclusive
1004 to 9884 inclusive	1.0 megohms to 9.88 megohms, inclusive

MIL-PRF-55182G

TABLE IV. Standard resistance values for the 10 decade to 100 decade.

0.1 (B) <u>1/</u>	0.5 (D)	1.0 (F)	0.1 (B) <u>1/</u>	0.5 (D)	1.0 (F)	0.1 (B) <u>1/</u>	0.5 (D)	1.0 (F)	0.1 (B) <u>1/</u>	0.5 (D)	1.0 (F)
10.00	---	10.00	18.40	---	---	32.80	---	---	56.20	---	56.20
10.10	---	---	18.70	---	18.70	---	---	---	56.90	---	---
10.20	10.20	18.90	---	---	---	33.20	33.20	57.60	---	---	57.60
10.40	---	19.10	19.10	---	---	33.60	---	58.30	---	---	---
10.50	10.50	19.30	---	---	---	34.00	34.00	59.00	---	---	59.00
10.60	---	19.60	19.60	---	---	34.40	---	59.70	---	---	---
10.70	10.70	19.80	---	---	---	34.80	34.80	60.40	---	---	60.40
10.90	---	20.00	20.00	---	---	35.20	---	61.20	---	---	---
11.00	11.00	20.30	---	---	---	35.70	35.70	61.90	---	---	61.90
11.10	---	20.50	20.50	---	---	---	---	---	---	---	---
11.30	11.30	20.80	---	---	---	36.10	---	62.60	---	---	---
11.40	---	21.00	21.00	---	---	36.50	36.50	63.40	---	---	63.40
11.50	11.50	21.30	---	---	---	37.00	---	64.20	---	---	---
11.70	---	21.50	21.50	---	---	37.40	37.40	64.90	---	---	64.90
11.80	11.80	21.80	---	---	---	37.90	---	65.70	---	---	---
12.00	---	---	---	---	---	38.30	38.30	66.50	---	---	66.50
12.10	12.10	22.10	22.10	---	---	38.80	---	67.30	---	---	---
12.30	---	22.30	---	---	---	---	---	---	---	---	---
12.40	12.40	22.60	22.60	---	---	39.20	39.20	68.10	---	---	68.10
12.60	---	22.90	---	---	---	39.70	---	69.00	---	---	---
12.70	12.70	23.20	23.20	---	---	40.20	40.20	69.80	---	---	69.80
12.90	---	23.40	---	---	---	40.70	---	70.60	---	---	---
13.00	13.00	23.70	23.70	---	---	41.20	41.20	71.50	---	---	71.50
13.20	---	24.00	---	---	---	41.70	---	72.30	---	---	---
13.30	13.30	24.30	24.30	---	---	42.20	42.20	73.20	---	---	73.20
13.50	---	24.60	---	---	---	42.70	---	74.10	---	---	---
13.70	13.70	24.90	24.90	---	---	---	---	75.00	---	---	75.00
13.80	---	25.20	---	---	---	43.20	43.20	75.90	---	---	---
14.00	14.00	25.50	25.50	---	---	43.70	---	76.80	---	---	76.80
14.20	---	25.80	---	---	---	44.20	44.20	77.70	---	---	---
14.30	14.30	26.10	26.10	---	---	44.80	---	78.70	---	---	78.70
14.50	---	26.40	---	---	---	45.30	45.30	79.60	---	---	---
14.70	14.70	26.70	26.70	---	---	45.90	---	80.60	---	---	80.60
14.90	---	---	---	---	---	46.40	46.40	81.60	---	---	---
15.00	15.00	27.10	---	---	---	47.00	---	---	---	---	---
15.20	---	27.40	27.40	---	---	47.50	47.50	82.50	---	---	82.50
15.40	15.40	27.70	---	---	---	48.10	---	83.50	---	---	---
15.60	---	28.00	28.00	---	---	48.70	48.70	84.50	---	---	84.50
15.80	15.80	28.40	---	---	---	49.30	---	85.60	---	---	---
16.00	---	28.70	28.70	---	---	49.90	49.90	86.60	---	---	86.60
16.20	16.20	29.10	---	---	---	50.50	---	87.60	---	---	---
16.40	---	29.40	29.40	---	---	---	---	88.70	---	---	88.70
16.50	16.50	29.80	---	---	---	51.10	51.10	89.80	---	---	---
16.70	---	---	---	---	---	51.70	---	90.90	---	---	90.90
16.90	16.90	30.10	30.10	---	---	52.30	52.30	---	---	---	---
17.20	---	30.50	---	---	---	53.00	---	92.00	---	---	---
17.40	17.40	30.90	30.90	---	---	53.60	53.60	93.10	---	---	93.10
17.60	---	31.20	---	---	---	54.20	---	94.20	---	---	---
17.80	17.80	31.60	31.60	---	---	54.90	54.90	95.30	---	---	95.30
18.00	---	32.00	---	---	---	55.60	---	96.50	---	---	---
18.20	18.20	32.40	32.40	---	---	---	---	97.60	---	---	97.60
								98.80	---	---	---

1/ The resistance values for tolerance B may be of any value, but it is preferred that the values be chosen from the resistance tolerance D values in this specification.

MIL-PRF-55182G

1.2.1.4 Resistance tolerance. The resistance tolerance is identified by a single letter in accordance with table V.

TABLE V. Resistance tolerance.

Symbol	Resistance tolerance (\pm)
B ^{1/}	0.1
D	0.5
F	1.0

^{1/} Not applicable to characteristic K.

1.2.1.5 Product level designator. The product level designator is specified in table VI by a single letter which identifies nonestablished reliability, established reliability or space level resistors.

TABLE VI. Product level designator.

Failure-rate level designation	Failure rate percent/1,000 hours
C	Non-ER
M	1.0
P	0.1
R	0.01
S	0.001
T	Space level

2. APPLICABLE DOCUMENTS

2.1 General. The documents listed in this section are specified in sections 3 and 4 of this specification. This section does not include documents cited in other sections of this specification or recommended for additional information or as examples. While every effort has been made to ensure the completeness of this list, document users are cautioned that they must meet all specified requirements documents cited in sections 3 and 4 of this standard, whether or not they are listed.

2.2 Government documents.

2.2.1 Specifications, standards, and handbooks. The following specifications, standards, and handbooks form a part of this document to the extent specified herein. Unless otherwise specified, the issues of these documents are those listed in the issue of the Department of Defense Index of Specifications and Standards (DoDISS) and supplement thereto, cited in the solicitation (see 6.2).

STANDARDS

DEPARTMENT OF DEFENSE

- MIL-STD-202 - Test Methods for Electronic and Electrical Component Parts, Test Methods for.
- MIL-STD-690 - Failure Rate Sampling Plans and Procedures.
- MIL-STD-790 - Standard Practice for Established Reliability and High Reliability Qualified Products List (QPL) Systems for Electrical, Electronic, and Fiber Optic Parts Specifications.
- MIL-STD-810 - Environmental Test Methods and Engineering Guidelines.
- MIL-STD-883 - Microelectronics, Test Methods and Procedures for.
- MIL-STD-1276 - Leads for Electronic Component Parts.
- MIL-STD-1285 - Marking of Electrical and Electronic Parts.

MIL-PRF-55182G

(See supplement 1 for list of associated specifications.)

(Unless otherwise indicated, copies of federal and performance specifications, standards, and handbooks are available from the Defense Printing Service Detachment Office, Bldg. 4D, Customer Service, 700 Robbins Avenue, Philadelphia, PA 19111-5094.

2.3 Non-Government publications. The following documents form a part of this document to the extent specified herein. Unless otherwise specified, the issues of the documents which are DoD adopted are those listed in the issue of the DoDISS cited in the solicitation. Unless otherwise specified, the issues of documents not listed in the DoDISS are the issues of the documents cited in the solicitation (see 6.2).

AMERICAN SOCIETY FOR TESTING AND MATERIALS (ASTM)

- ASTM E595 - Materials from Outgassing in a Vacuum Environment, Total Mass Loss and Collected Volatile Condensable, Standard Test Method for.
- ASTM D1193 - Standard Specification for Reagent Water (Federal Test Method Standard No. 7916).

(Application for copies should be addressed to the American Society for Testing and Materials, 1916 Race Street, Philadelphia, PA 19103.)

ELECTRONIC INDUSTRIES ASSOCIATION (EIA)

- EIA-557 - Statistical Process Control Systems.
- EIA-554-1 - Assessment of Average Outgoing Quality Levels in Parts Per Million (PPM). (DoD adopted)

(Application for copies should be addressed to the Electronic Industries Association, 2001 Eye Street, NW, Washington, DC 20006.)

NATIONAL AERONAUTICS AND SPACE ADMINISTRATION (NASA)

- NASA 1124 - Outgoing Data for Selecting Spacecraft Materials.

(Application for copies should be addressed to NASA/Parts Project Office (NPPO), NASA Goddard Space Flight Center, Code 310.A, Greenbelt, MD 20771.)

(Non-Government standards and other publications are normally available from the organizations that prepare or distribute the documents. These documents also may be available in or through libraries or other informational services.)

2.4 Order of precedence. In the event of a conflict between the text of this document and the references cited herein (except for related associated specifications, specification sheets, or MS standards), the text of this document takes precedence. Nothing in this document, however, supersedes applicable laws and regulations unless a specific exemption has been obtained.

3. REQUIREMENTS

3.1 Specification sheet. The individual item requirements shall be as specified herein and in accordance with the applicable specification sheet. In the event of any conflict between the requirements of this specification and the specification sheet, the latter shall govern.

3.2 Qualification. Resistors furnished under this specification shall be products that are authorized by the qualifying activity for listing on the applicable qualified products list before contract award (see 4.4, 6.3, and appendix A). In addition, the manufacturer shall obtain certification from the qualifying activity that the QPL system requirements of 3.3 and 4.2 have been met and are being maintained.

MIL-PRF-55182G

3.3 Qualified Products List (QPL) system. The manufacturer shall establish and maintain a QPL system for parts covered by this specification. Requirements for this system are specified in MIL-STD-790 (all product levels) and MIL-STD-690 (ER parts only). In addition, the manufacturer shall also establish a Statistical Process Control (SPC) and Part Per Million (PPM) system that meets the requirements as described in 3.3.1 and 3.3.2 respectively.

3.3.1 SPC system. As part of the overall MIL-STD-790 QPL system, the manufacturer shall establish an SPC system that meets the requirements of EIA-557. Typical manufacturing processes for application of SPC include film deposition, cap/lead attachment, laser trimming, encapsulation, and weld strength. In addition, the manufacturer shall demonstrate resistance temperature characteristic (RTC) control in the process.

3.3.2 PPM system. As part of the overall MIL-STD-790 QPL system, the manufacturer shall establish an PPM system for assessing the average outgoing quality of lots in accordance with EIA-554-1 and 4.6.4. Data exclusion, in accordance with EIA 554-1, may be used with approval of the qualifying activity. The PPM system shall identify the PPM rate at the end of each month and shall be based on a six month moving average. PPM-2, direct current (dc) resistance, shall be assessed for each style. Style reporting may include both non-ER and ER style combinations. Due to low production volume, PPM assessment does not apply to space level lots.

3.4 Materials. The material shall be as specified herein. However, when a definite material is not specified, a material shall be used which will enable the resistors to meet the performance requirements of this specification. Acceptance or approval of any constituent material shall not be construed as a guarantee of the acceptance of the finished product.

3.5 Interface and physical dimension requirements. Resistors shall meet the interface and physical dimensions specified (see 3.1). Each resistor, except those supplied under characteristic H, characteristic J, and characteristic K, shall consist of a film type resistance element, protected from exposure to humidity by a hermetically sealed enclosure (see 3.12). Characteristic H, characteristic J, and characteristic K resistors shall consist of a film element, but is not required to be hermetically sealed (see 3.12.1).

3.5.1 Aqueous-extract conductivity. The manufacturer shall verify by certification that the aqueous-extract conductivity, when determined as specified in 4.8.27, does not exceed the values shown below for the incoming materials for the parts indicated.

<u>Part</u>	<u>Maximum conductivity MHOS per CM)</u>
Core -----	1.0×10^{-6}
Shell (with metalized ends) -----	2.0×10^{-6}

3.5.1.1 Metalizing of shell ends. Metalizing, when used, shall be uniform around the periphery of the ends of the shell, shall be well bonded to the base material, and shall provide a good seal with the mating part.

3.5.2 Films. Films shall be uniformly deposited. The film shall be free of blisters, thin spots, areas inadequately bonded to core, discolored spots, or other blemishes likely to cause flaking or a nonuniform ribbon when spiraled (helixed). Where used, spiraling shall occupy no less than 70 percent of resistor-element actual length. The resistor-element actual length shall be defined as the nominal distance between terminal bands less three sixty-fourths of an inch.

3.5.3 Terminal leads. Terminal leads shall be made of a solid conductor of the length and diameter specified. The leads shall be solderable in accordance with method 208, MIL-STD-202 beyond the maximum specified clean-lead to clean-lead dimension in accordance with figure 1 and 3.1.

MIL-PRF-55182G

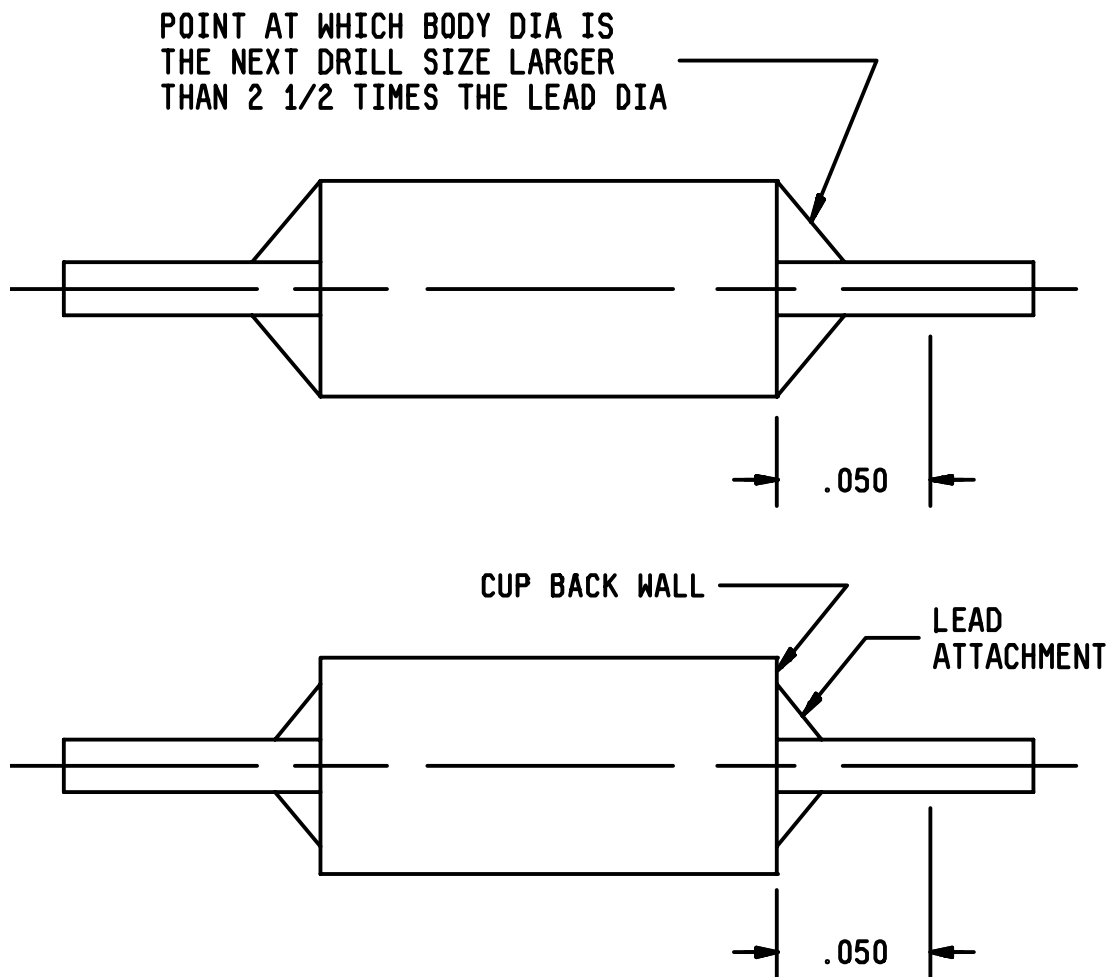

NOTE: Exposed copper or base metal due to lead attachment within .050 inch (1.27 mm) of the resistor body shall not be considered a reliability problem.

FIGURE 1. Terminal leads for molded and conformal coated construction.

3.5.3.1 Solderable leads. Solderable leads (and solderable/weldable leads) shall be suitably treated to meet the requirements of solderability (see 3.13).

3.5.3.2 Weldable leads. Weldable leads shall be as specified in table I. Manufacturers shall verify by certification that all leads conform to the applicable requirements of MIL-STD-1276. The maximum thickness of the coating for termination C lead shall not exceed twice the minimum thickness of any cross section.

3.5.3.3 Solder dip (retinning) leads. The manufacturer (or his authorized category B or category C distributor) may solder dip/retin the leads of product supplied to this specification provided the solder dip process has been approved by the qualifying activity. The manufacturer (or his authorized category B or category C distributor) shall maintain a solder purity in accordance with table VII, during the tinning process.

MIL-PRF-55182G

TABLE VII. Contamination limits.

Contamination	Tinning percent by weight <u>1/</u>
Copper	.75
Gold	.50
Cadmium	.01
Zinc	.008
Aluminum	.008
Antimony	.50
Iron	.02
Arsenic	.03
Bismuth	.25
Silver	.75
Nickel	.025

1/ This is a fixed percentage by weight of the solder.

3.5.3.3.1 Qualifying activity approval. Approval of the solder dip process will be based on one of the following options:

- a. When the original lead finish qualified was hot solder dip lead finish 52 of MIL-STD-1276. (Note: The 200 microinch thickness is not applicable.) The manufacturer shall use the same solder dip process for retooling as is used in the original manufacture of the product.
- b. When the lead originally qualified was not hot solder dip lead finish 52 of MIL-STD-1276 as prescribed in 3.5.3.3.1a., approval for the process to be used for solder dip shall be based on the following test procedure:
 - (1) Thirty samples of any resistance value for each style and lead finish are subjected to the manufacturing's solder dip process. Following the solder dip process, the resistors are subject to the direct current resistance test and other group A electricals. (Note: If hermetic seal testing is required in group A, these tests would also be performed.) No defects are allowed.
 - (2) Ten of the 30 samples are then subjected to the solderability test. No defects are allowed.
 - (3) The remaining 20 samples are subjected to the resistance to solder heat test followed by the moisture resistance test (or hermetic seal test if the device is hermetically sealed). No defects are allowed.

3.5.3.3.2 Solder dip/retooling options. The manufacturer (or authorized category B or category C distributor) may solder dip/retool as follows:

- a. After the 100 percent group A screening tests. Following the solder dip/retooling process, the electrical measurements required in group A, subgroup 1, 100 percent screening tests shall be repeated on 100 percent of the lot. (NOTE: The manufacturer may solder dip/retool prior to the 100 percent electrical measurements of the group A, subgroup 1 tests.) The percent defective allowance (PDA) (see 4.6.3.2.1) for the electrical measurements shall be as for the subgroup 1 tests. (NOTE: If hermetic seal is required in group A, subgroup 1, this test must be performed after the solder dip/retooling process or they will have to be repeated.)

MIL-PRF-55182G

- b. As a corrective action. If the lot fails the group A solderability tests, the lot may be retinned no more than two times. The lot after retinning shall be 100 percent screened for group A electrical requirements (dc resistance). Any parts failing (lot not exceeding PDA for group A, subgroup 1, see 4.6.3.2.1) these screens shall not be supplied to this specification. If electrical failures exceeding 1 percent of the lot are detected after the second retinning operation, the lot shall not be supplied to this specification.
- c. After the group A inspection has been completed. Following the solder dip/retinning process, the electrical measurements required in group A, subgroup 1, 100 percent screening test shall be repeated on 100 percent of the lot. The PDA for the electrical measurements shall be as for the subgroup 1 tests. (NOTE: If hermetic seal is required in the group A, subgroup 1 tests, this test shall be repeated, see 4.6.3.2.1.) Following these tests, the manufacturer shall submit the lot to the group A solderability test as specified in 4.8.7.

3.5.3.4 Tin plated finishes. Use of tin plating is prohibited as a final finish and as an undercoat (see 6.8). Use of tin-lead (Sn-Pb) finishes are acceptable provided that the minimum lead content is 3 percent.

3.5.4 Flux. Flux shall be of such a quality as to enable the film resistors to meet all the requirements of this specification.

3.5.5 End caps. When end caps are used in construction of the resistor, the misalignment of the cap with respect to the core shall not exceed 3 degrees.

3.5.6 Insulation. Insulation material surrounding the resistor body shall extend around the entire shoulder of each end cap toward the axis of the lead attachments. Complete back wall coverage is optional.

3.6 Power rating. Resistors shall have a power rating based on continuous full-load operation at an ambient temperature of +125°C. This power rating is dependent on the ability of resistors to meet the life requirements specified in 3.24. For temperatures in excess of those specified above, the load shall be derated in accordance with figure 2.

3.7 Voltage rating. Resistors shall have a rated direct current continuous working voltage or an approximate sine-wave root mean square (rms) continuous working voltage at commercial line frequency and waveform corresponding to the power rating, as determined from the following formula.

$$E = \sqrt{PR}$$

Where:

- E = rated dc or rms continuous working voltage.
- P = power rating (see 3.1).
- R = nominal resistance.

In no case shall the rated dc or rms continuous working voltage be greater than the applicable maximum value (see 3.1 and table I of supplement 1).

3.8 Thermal shock. When resistors are tested as specified in 4.8.2, there shall be no evidence of mechanical damage; the change in resistance shall not exceed $\pm(0.20 \text{ percent} + 0.01 \text{ ohm})$ for thermal shock and overload tests combined (see 3.9). For the 100 cycle qualification test for space level resistors, the change in resistance shall not exceed $\pm(0.20 \text{ percent} + 0.01 \text{ ohm})$.

3.9 Overload. When resistors are tested as specified in 4.8.3, there shall be no evidence of arching, burning, or charring; the change in resistance shall not exceed $\pm(0.20 \text{ percent} + 0.01 \text{ ohm})$ for thermal shock and overload tests combined (see 3.8).

3.10 Power conditioning (space level only). When resistors are tested as specified in 4.8.4, there shall be no evidence of mechanical damage and the change in resistance shall not exceed $\pm(0.20 \text{ percent} + 0.01 \text{ ohm})$ or 3 standard deviations, whichever is less, for thermal shock, overload, and power conditioning tests combined.

MIL-PRF-55182G

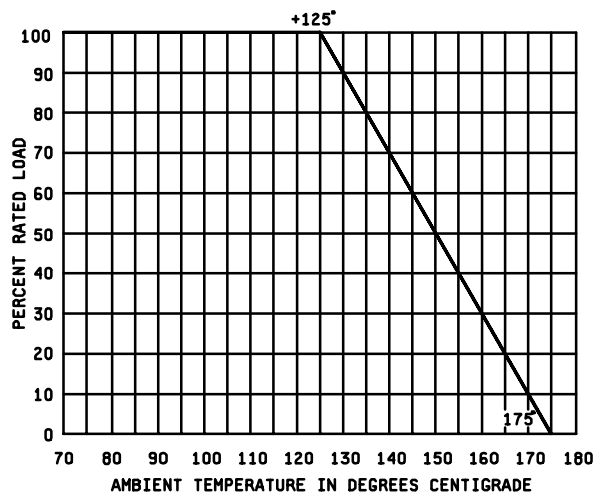

NOTE: These curves indicate the percentage of nominal wattage to be applied at temperatures higher than +125°C. However, at no time shall the applied voltage exceed the maximum for each style.

FIGURE 2. Derating curve for high ambient temperatures.

3.11 DC resistance. When resistors are tested as specified in 4.8.5, the dc resistance shall be within the specified tolerance of the nominal resistance (see 1.2.1.4).

3.12 Hermetic seal (applicable to characteristic C and characteristic E). For the purposes of this specification, a hermetically sealed resistor is one in which the resistance element is contained within a sealed enclosure of ceramic, glass, or metal, or combinations thereof. The resistors supplied under characteristic C and characteristic E shall be capable of passing the seal test specified in 4.8.6 or of meeting a leak rate requirement of not more than 1×10^{-8} cubic centimeters (cc) per second, when determined by method 112 of MIL-STD-202, procedure IV, and there shall be no evidence of dye emanating from the resistor when tested in accordance with method 1014 of MIL-STD-883, condition D.

3.12.1 Nonhermetic seal (applicable to characteristic H, characteristic J, characteristic and K). For the purpose of this specification, a nonhermetically sealed resistor is one not conforming in full to the requirements of 3.12. A qualified resistor which meets all requirements of 3.12 may be furnished to meet these characteristics; however, the resistor must continue to meet all requirements of the C or E characteristic. Characteristic H, characteristic J, and characteristic K resistors shall not be furnished against C requirements and E requirements.

3.13 Solderability (applicable to solderable, solderable/weldable terminals only). When resistors are tested as specified in 4.8.7, they shall meet the criteria for wire-lead terminal evaluation in the test method.

3.14 Resistance to solvents. When resistors are tested as specified in 4.8.8, there shall be no evidence of mechanical damage and the marking shall remain legible.

3.15 Resistance temperature characteristic. When resistors are tested as specified in 4.8.9, the resistance-temperature characteristic, at each of the temperatures specified in table XIX, referenced to room ambient temperature (25°C), shall not exceed the value specified in table II for the applicable characteristic.

3.16 Low temperature operation. When resistors are tested as specified in 4.8.10, there shall be no evidence of mechanical damage. The change in resistance shall not exceed $\pm(0.15 \text{ percent} + 0.01 \text{ ohm})$.

MIL-PRF-55182G

3.17 Terminal strength. When resistors are tested as specified in 4.8.11, there shall be no evidence of breaking or loosening of terminals from the resistor form, or chipping of coating, or other evidence of mechanical damage. The change in resistance shall not exceed $\pm(0.20 \text{ percent} + 0.01 \text{ ohm})$.

3.18 Dielectric withstanding voltage. When resistors are tested as specified in 4.8.12, there shall be no evidence of flashover, mechanical damage, arcing, or insulation breakdown. The change in resistance shall not exceed $\pm(0.15 \text{ percent} + 0.01 \text{ ohm})$.

3.19 Insulation resistance. When resistors are tested as specified in 4.8.13, the insulation resistance shall be not less than 10,000 megohms.

3.20 Resistance to soldering heat. When resistors are tested as specified in 4.8.14, there shall be no evidence of mechanical damage. The change in resistance shall not exceed $\pm(0.10 \text{ percent} + 0.01 \text{ ohm})$.

3.21 Moisture resistance. When resistors are tested as specified in 4.8.15, there shall be no evidence of mechanical damage. The change in resistance for characteristic H, characteristic J, and characteristic K shall not exceed $\pm(0.40 \text{ percent} + 0.01 \text{ ohm})$; for characteristic C and characteristic E, the change in resistance shall not exceed $\pm(0.20 \text{ percent} + 0.01 \text{ ohm})$. In addition, the dielectric withstanding voltage shall be as specified in 3.18, and the insulation resistance shall be 100 megohms, minimum.

3.22 Shock (specified pulse). When resistors are tested as specified in 4.8.16, there shall be no evidence of mechanical or electrical damage. The change in resistance shall not exceed $\pm(0.20 \text{ percent} + 0.01 \text{ ohm})$. There shall be no electrical discontinuity during the test.

3.23 Vibration, high frequency. When resistors are tested as specified in 4.8.17, there shall be no evidence of mechanical damage. The change in resistance shall not exceed $\pm(0.20 \text{ percent} + 0.01 \text{ ohm})$. There shall be no electrical discontinuity during the test.

3.24 Life.

3.24.1 Qualification. When resistors are tested as specified in 4.8.18, there shall be no evidence of mechanical damage. The change in resistance between the initial measurement and any of the succeeding measurements up to and including 2,000 hours, shall not exceed $\pm(0.50 \text{ percent} + 0.01 \text{ ohm})$.

3.24.2 FR determinaton (ER only). When resistors are tested as specified in 4.8.18, there shall be no evidence of mechanical damage to the resistance element or enclosure. The change in resistance between the initial measurement and any of the succeeding measurements shall not exceed $\pm(2.0 \text{ percent} + 0.01 \text{ ohm})$. This single failure criteria shall be applicable to all measurements during the life test for purposes of determining FR level qualification and is applicable as a parallel requirement with 3.24.1 to the measurements made during the life test specified for qualification inspection.

3.24.3 +70°C power rating. For qualification testing only, resistors shall be subjected to the specified voltage and shall dissipate the assigned +70°C wattage rating for a 2,000-hour duration. The change in resistance shall not exceed $\pm(0.50 \text{ percent} + 0.01 \text{ ohm})$. The data acquired is not applicable to the establishment, maintenance, or extension of FR level (see 3.1 and 6.11).

3.25 High temperature exposure. When resistors are tested as specified in 4.8.19, there shall be no evidence of mechanical damage and the change in resistance shall not exceed $\pm 2 \text{ percent}$ (except characteristic Y shall be $\pm 0.5 \text{ percent}$) at a maximum temperature of +175°C. Following this test, the dielectric withstanding voltage shall be as specified in 3.18 and the insulation resistance shall be 1,000 megohm, minimum.

3.26 Voltage coefficient (applicable to resistors of 1,000 ohms and over). When resistors are tested as specified in 4.8.20, the voltage coefficient shall not exceed the value specified (see 3.1).

MIL-PRF-55182G

3.27 Fungus. All external materials shall be nonnutrient to fungus growth or shall be suitably treated to retard fungus growth. The manufacturer shall verify by certification that all external materials are fungus resistant or shall test resistors as specified in 4.8.21. There shall be no evidence of fungus growth on the external surfaces.

3.28 Mechanical shear (when applicable, see 3.1). When resistors are tested as specified in 4.8.22, there shall be no evidence of mechanical damage and the change in resistance shall not exceed $\pm(0.20 \text{ percent} + 0.01 \text{ ohm})$.

3.29 Low temperature storage. When resistors are tested as specified in 4.8.23, there shall be no evidence of mechanical damage. The change in resistance shall not exceed $\pm(0.15 \text{ percent} + 0.01 \text{ ohm})$.

3.30 Resistance noise (space level only). When tested in accordance with 4.8.24, the third harmonic index (THI) shall be screened to accept only product within a ± 3 standard deviation.

3.31 Destructive physical analysis (space level only). When examined as specified in 4.8.25, resistors shall meet the requirements in appendix B of this document.

3.32 Outgassing (space level only). When examined as specified in 4.8.26, the samples shall meet the following requirements:

- a. Total mass loss (Tml) shall not exceed 1 percent.
- b. Volatile condensable material (VCM) shall not exceed 0.1 percent.

3.32.1 Outgassing test data. Data listed in NASA Publication 1124 may be used in lieu of actual test data for applicable materials.

3.33 Resistance value deviations. All maximum deviations as specified in this section are to be considered absolute limits with the exception of the contact resistance adjustments.

3.34 Marking.

3.34.1 Full marking. Resistors shall be marked with type designation, "JAN" marking, date code, source code, and manufacturer's production lot code (see 6.2). Date and source code shall be in accordance with MIL-STD-1285. At the option of the manufacturer, the type designation may appear on two lines. In this event, the type designation shall be divided between the characteristic letter and the first digit of the resistance value. The following is an example of the complete marking:

12345	-	CAGE code
7242J	-	Date code and JAN marking
RNR60C	-	Style, terminal type, and characteristic
49R9FM	-	Resistance, tolerance and FR type designation
*****	-	Manufacturers production code

The date code shall be the date of the final assembly operation for the production lot as defined in 4.6.2.2. The common manufacturing record shall include the same date code as that placed on the parts covered by the record.

3.34.2 Minimum marking. When the physical size of the resistor style precludes the marking of all the above information, the minimum marking required shall be as specified in the associated specification (see 3.1). Marking shall remain legible at the end of tests. In those cases where full marking requirements are not on the resistor body, the full marking shall be marked on the unit package.

MIL-PRF-55182G

3.34.3 JAN and J marking. The United States Government has adopted, and is exercising legitimate control over the certification marks "JAN" and "J", respectively, to indicate that items so marked or identified are manufactured to, and meet all the requirements of specifications. Accordingly, items acquired to, and meeting all of the criteria specified herein and in applicable specifications shall bear the certification mark "JAN" except that items too small to bear the certification mark "JAN" shall bear the letter "J". The "JAN" or "J" shall be placed immediately before the part number except that if such location would place a hardship on the manufacturer in connection with such marking, the "JAN" or "J" may be located on the first line above or below the part number. Items furnished under contracts or orders which either permit or require deviation from the conditions or requirements specified herein or in applicable specifications shall not bear "JAN" or "J". In the event an item fails to meet the requirements of this specification and the applicable associated specifications, the manufacturer shall remove completely the military part number and the "JAN" or "J" from the sample tested and also from all items represented by the sample. The "JAN" or "J" certification mark shall not be used on products acquired to contractor drawings or specifications. The United States Government has obtained Certificate of Registration Number 504,860 for the certification mark "JAN" and Registration Number 1,586,261 for the certification mark "J".

3.34.4 Supplying to higher FR levels and product levels. A manufacturer may supply to all higher product levels to which he is qualified. Parts qualified and marked to lower (i.e., more stringent) product levels, with procuring agency approval, are substitutable for higher product levels, and shall not be remarked unless specified in the contract or order (see table VIII).

TABLE VIII. Failure-rate substitution.

FR	FR substitution
T (space)	T
S (.001)	T, S
R (.01)	T, S, R
P (0.1)	T, S, R, P
M (1.0)	T, S, R, P, M
C (non-ER)	T, S, R, P, M

3.34.5 Supplying to lower resistance temperature characteristics and/or lower resistance tolerances. Parts qualified to lower resistance temperature characteristics and/or lower resistance tolerance levels, with procuring agency approval, are substitutable for parts marked to higher resistance temperature or higher tolerance levels and shall not be remarked unless specified in the contract or order (see 6.2) (see table IX and table X).

TABLE IX. Resistance tolerance substitution.

Resistance tolerance	Resistance tolerance substitution
B D F	B B, D

MIL-PRF-55182G

TABLE X. Characteristic substitution.

Characteristic	Characteristic substitution
E C J H K	E J J, K

3.34.6 Use of conductive inks. Conductive inks shall not be used to coat the body of the resistor as preparation for marking or used for marking of resistors.

3.34.7 Part style substitutability. As determined by the procuring activity, the RNR style and the RNC style are interchangeable for the applicable characteristics. Substitution of these styles may occur only with approval of the procuring activity.

3.35 Workmanship. Resistors shall be processed in such a manner as to be uniform in quality and shall be free from any defects that will affect life, serviceability, or appearance.

3.35.1 Soldering. Electrical connections shall be mechanically secure before and electrically continuous after soldering.

3.35.2 Recycled, recovered, or environmentally preferable materials. Recycled, recovered, or environmentally preferable materials should be used to the maximum extent possible provided that the materials meets or exceeds the operational and maintenance requirements, and promotes economically advantageous life cycle costs.

4. VERIFICATION

4.1 Classification of inspection. The inspection requirements specified herein are as follows:

- a. Qualification inspection (see 4.4).
- b. Verification of qualification (see 4.5).
- c. Conformance inspection (see 4.6).
- d. Periodic group C inspection (see 4.7).

4.2 Reliability and quality.

4.2.1 QPL system. The manufacturer shall establish and maintain a QPL system as described in 3.3. Evidence of such compliance is a prerequisite for qualification and retention of qualification.

4.2.2 SPC. A SPC program shall be maintained in accordance with EIA-557. Evidence of such compliance shall be verified by the qualifying activity of this specification as a prerequisite for qualification and continued qualification.

4.3 Inspection conditions and precautions.

4.3.1 Inspection conditions. Unless otherwise specified herein, all inspections shall be performed in accordance with the test conditions specified in the "GENERAL REQUIREMENTS" of MIL-STD-202.

4.3.2 Precautions. Adequate precautions shall be taken during inspection to prevent condensation of moisture

MIL-PRF-55182G

on resistors, except during the moisture resistance temperature cycling tests.

4.4 Qualification inspection. Qualification inspection shall be performed at a laboratory acceptable to the Government (see 6.3).

4.4.1 Sample. The number of sample units comprising a sample of resistors to be submitted for qualification inspection shall be as specified in table XX of the appendix to this specification. The sample shall be taken at random from a production run and shall be produced with equipment and procedures normally used in production. Each resistor style shall be qualified separately.

4.4.2 Test routine. Sample units shall be subjected to the qualification inspection specified in table XI, in the order shown. All samples units, with the exception of 12 samples for group IA inspection, shall be subjected to the inspection of group I. The 304 sample units shall then be divided as specified in table XI for group II to group VII inclusive, and subjected to the inspection for their particular group. Two additional unenclosed sample units shall be subjected to the visual and mechanical examination of group I only. Sample sizes and extent of qualification for characteristics shall be as specified in the appendix to this specification. For the purpose of verifying the +70°C power rating (see 3.1 and 6.11), a separate sample of 102 units shall be subjected to group I and group VA of table XI. This test is an initial qualification requirement only.

4.4.3 Defective. Defectives in excess of those allowed in table XI shall be cause for refusal to grant qualification.

MIL-PRF-55182G

TABLE XI. Qualification inspection.

Inspection	Requirements paragraph	Method paragraph	Number of samples	Number of defects permitted
<u>Certification requirements</u> Aqueous-extract-conductivity <u>2/</u> Flux <u>2/</u> Outgassing (space level only)	3.5.1 3.5.4 3.32	4.8 4.8.26		<u>1/</u>
<u>Group I</u> Visual and mechanical examination <u>3/</u> Thermal shock <u>4/</u> Overload <u>4/</u> DC resistance <u>4/</u> Hermetic seal (when applicable) <u>4/</u>	3.1, 3.4, 3.5, 3.5.1.1 through 3.5.3.2 inclusive, 3.5.5, 3.31, 3.31.1, and 3.32 3.8 3.9 3.11 3.12	4.8.1 4.8.2 4.8.3 4.8.5 4.8.6	All sample units	N/A
<u>Group IA</u> Solderability Resistance to solvents	3.13 3.14	4.8.7 4.8.8	12 sample units	0
<u>Group II</u> Resistance temperature characteristics Low temperature storage Low temperature operation Terminal strength Hermetic seal (when applicable)	3.15 3.29 3.16 3.17 3.12	4.8.9 4.8.23 4.8.10 4.8.11 4.8.6	30 10 highest 10 critical 10 lowest	<u>5/ 1</u>
<u>Group III</u> Dielectric withstanding voltage Insulation resistance Resistance to soldering heat Moisture resistance	3.18 3.19 3.20 3.21	4.8.12 4.8.13 4.8.14 4.8.15	30 10 highest 10 critical 10 lowest	N/A
<u>Group IV</u> Shock (specified pulse) Vibration, high frequency Hermetic seal (when applicable)	3.22 3.23 3.12	4.8.16 4.8.17 4.8.6	30 10 highest 10 critical 10 lowest	N/A

See footnotes at end of table.

MIL-PRF-55182G

TABLE XI. Qualification inspection - Continued.

Inspection	Requirements paragraph	Method paragraph	Number of samples	Number of defects permitted
<u>Group V</u> Life	3.24	4.8.18	102 34 highest 34 critical 34 lowest	1
<u>Group VA</u> <u>6/</u> +70°C power rating	3.24.3	4.8.18	102 34 highest 34 critical 34 lowest	1
<u>Group VI</u> High temperature exposure	3.25	4.8.19	<u>7/</u> 102 34 highest 34 critical 34 lowest	1
<u>Group VII</u> Voltage coefficient (applicable to resistors of 1,000 ohms and over) Fungus Mechanical shear (when applicable)	3.26 3.27 3.28	4.8.20 4.8.21 4.8.22	10 highest	0
<u>Group VIII (space level only)</u> Thermal shock (100 cycles)	3.8	4.8.2	30 samples 10 highest 10 critical 10 lowest	0

1/ Failure of a resistor in one or more tests of a group shall be charged as a single defect.

2/ The manufacturer shall verify by certification that these requirements have been met in fabricating resistors furnished to this specification.

3/ Marking shall be considered defective if the marking is illegible or incorrect. The two additional unenclosed sample units shall be subjected to the visual and mechanical examination of group I only. Marking shall remain legible at the end of all tests.

4/ As an option, the manufacturer may perform group A, subgroup 1 tests with the required PDA in lieu of these tests.

5/ For characteristic C and characteristic E, zero failures are permitted in moisture resistance.

6/ The power rating shall be +70°C. Qualification inspection only.

7/ Ten sample units shall be subjected to dielectric withstanding voltage and insulation resistance following this test.

MIL-PRF-55182G

4.4.4 FR level verification (ER only).

4.4.4.1 FR qualification. FR qualification shall be in accordance with the requirements of MIL-STD-690 and the following details:

- a. Procedure: Qualification at the initial FR level. Level M (1.0 percent) of FRSP-60 shall apply. Sample units shall be subjected to the qualification inspection specified in group V, table XI (see 4.4.2). Entire life test sample shall be continued on test to 10,000 as specified in 4.8.18, upon completion of the 2,000 hour qualification.
- b. Procedure II: Extension of qualification to lower FR levels. To extend qualification to the R (0.01 percent) and S (0.001 percent), FR level unit hours of two or more styles of similar construction may be combined.
- c. Procedure III: Maintenance of FR levels qualification. Maintenance period A of FRSP-10 shall apply. Regardless of the number of production lots produced during this period, the specified number of unit hours shall be accumulated to maintain qualification (see 4.7). For FR level R and level S, all lead types may be combined.

4.5 Verification of qualification. Every 6 months the manufacturer shall provide verification of qualification to the qualifying activity. Continuation of qualification is based on meeting the following requirements.

- a. MIL-STD-790 program.
- b. Design of resistor has not been modified.
- c. Lot rejection for group A (subgroup 2 and subgroup 5) and group B does not exceed 5 percent or one lot, whichever is greater. (NOTE: Group B, subgroup 2, is not included in lot rejection rate).
- d. Periodic group C inspection.
- e. FR rate levels.
- f. PPM assessment (NOTE: Grouping of styles is permitted).
- g. Continued qualification to the non-ER level (C) shall be based on continued maintenance of qualification for the ER part (minimum P FR rate level maintenance).
- h. Continued qualification to the space level (T) shall be based on maintaining minimum ER FR level of S (R for RNC90) and maintenance of the test capability and lot control system for testing space level resistors.

4.6 Conformance inspection.4.6.1 Inspection of product for delivery.

4.6.1.1 Non-ER resistors. Inspection of product for delivery shall consist of the requirements in 4.6.3.1.

4.6.1.2 ER resistors. Inspection of product for delivery shall consist of group A and group B inspection. Group B inspection for preparation of delivery is not required when the qualifying activity has allowed group B testing to be performed annually (see table XV).

4.6.1.3 Space level. Inspection of product for delivery shall consist of the group A and group B inspection.

MIL-PRF-55182G

4.6.2 Inspection and production lot.

4.6.2.1 Inspection lot. An inspection lot, as far as practical, shall consist of all the resistors of the same style, characteristic, and protective enclosure or coating and manufactured under essentially the same process and conditions during a manufacturing period of 1 month maximum. For purposes of lot formation, all terminal types may be included in the same lot; however, all lead types which are combined shall have the same method of terminal attachment. All leads in the lot shall be represented in a similar proportion by samples selected for inspection. Non-ER, ER, and space level lots shall be kept separate.

4.6.2.2 Production lot (ER and space level only). A production lot shall consist of all resistors of the same style, nominal resistance value, resistance tolerance, resistance temperature characteristic, and terminal type. Manufacture of all parts in the lot shall have been started, processed, assembled, and tested as a group. Lot identity shall be maintained throughout the manufacturing cycle. In addition, for space level production lots only; the deposition/metallization shall be restricted to slugs produced for a single resistor style; the slugs shall be processed in a single continuous metallization run on the same equipment; and the raw material used in the metallization process shall each be from the same raw material lot. Non-ER, ER and space level lots shall be kept separate.

4.6.3 Group A inspection.

4.6.3.1 Non-ER resistors. The manufacturer shall establish and maintain an inspection system to verify that resistors meet dc resistance, visual/mechanical examination, hermetic seal (when applicable), and solderability requirements. In-line or process controls may be part of such a system. The inspection system shall also include criteria for lot rejection and corrective actions. The inspection system shall be verified under the overall MIL-STD-790 QPL system. NOTE: Since the non-ER (C level) is the ER design without the mandatory conformance inspection and FR level assessment, this product is still expected to meet the environmental qualification type requirements (e.g., moisture resistance, shock, vibration, etc.).

4.6.3.2 ER and space level resistors. Group A inspection shall consist of the inspections and tests specified in table XII.

4.6.3.2.1 Subgroup 1 tests. Subgroup 1 tests shall be performed on a production lot basis on 100 percent of the lot. Resistors that are out of tolerance, or which experience a change in resistance greater than permitted, shall be removed from the lot and not supplied to this specification. Only lots having not more than 3 percent rejects for ER (5 percent for space level) or one resistor (which ever is greater) due to exceeding the resistance change limit, shall be furnished on contracts.

4.6.3.2.2 Manufacturers production inspection. If the manufacturer performs tests similar to those specified in the group A, subgroup 1, as the final step of their manufacturing process, the subgroup 1 tests may be eliminated when approved by the qualifying activity. The following criteria shall be used in making this determination:

- a. The production tests are identical or more stringent than the subgroup 1 tests.
- b. 100 percent of the product is subjected to these tests.
- c. Failure criteria are identical or more stringent than the subgroup 1 tests.
- d. Lot rejection criteria are identical or more stringent than the subgroup 1 tests.
- e. Once approved, future changes also require approval by the qualifying activity.

MIL-PRF-55182G

4.6.3.2.3 Subgroup 2 tests. The subgroup 2 tests shall be performed on an inspection lot basis for ER parts and on a production lot basis for space level parts. A random sample of resistors shall be selected in accordance with table XII. In the event of one or more failures, the lot is rejected. The rejected lot may be rescreened and the defects removed and resubmitted to the table XIII sample plan. If one or more defects are found in this second sample, the lot is rejected and shall not be supplied to this specification. (NOTE: This corrective action applies to the original quality defect found. If another defect type is found in the second sample, a rescreen for that defect is also permitted).

4.6.3.2.4 Subgroup 3 (solderability) test. The subgroup 3 test shall be performed on an inspection lot basis for ER parts and on a production lot basis for space level parts. A sample shall be selected from each lot in accordance with table XIV. As an option, the manufacturer may use electrical rejects from the subgroup 1 tests for all or part of the sample. If there are one or more defects, the lot is rejected. The manufacturer may use one of the following options for corrective action:

- a. Each production lot that was used to form the failed inspection lot shall be individually submitted to the solderability test. Production lots that pass are available for shipment. Production lots that fail can be submitted to the solder dip procedure of 4.6.3.2.4.b.
- b. The failed lot is submitted to a 100 percent hot solder dip using the approved solder dip process of 3.5.3.3. A subsequent solderability test shall then be performed. If the lot passes, it is available for shipment; if the lot fails, the manufacturer may perform the hot solder dip one additional time. If the lot fails to pass, the lot is considered rejected and shall not be supplied to this specification.

4.6.3.2.4.1 Disposition of samples. The solderability test is considered a destructive test and samples submitted to this test shall not be supplied on the contract.

4.6.3.2.5 Subgroup 4 (destructive physical analysis) (space level only). The subgroup 4 test shall only be performed on space level inspection lots. A sample of five parts shall be selected from each lot and submitted to test. If one or more defects are found the lot is rejected and shall not be supplied to this specification. This test is destructive and the samples submitted to this test shall not be supplied on the contract.

4.6.4 PPM assessment (non-ER and ER). The manufacturer shall establish and maintain a system for assessing the average outgoing quality in PPM of lots supplied to this specification. This PPM assessment should be based on inspections performed on each inspection lot to verify that resistors meet dc resistance and tolerance requirements (i.e., PPM-2). For ER resistors, this inspection shall occur after the group A, subgroup 1, 100 percent screens have been completed. In the event of one or more failures the lot is rejected.

4.6.4.1 Sampling plans. Minimum sample sizes for inspection lots shall be selected in accordance with table XIII. For non-ER resistors, the sampling system and plan used for the group A inspection (see 4.6.3.1) may be the basis for assessing PPM.

4.6.4.2 Rejected lots. Any rejected lot shall be segregated from new lots and those lots which have passed the PPM assessment. A rejected lot may be rescreened for the quality characteristics found defective in the sample and any defects removed. A new second sample shall be randomly selected. If one or more defects are found, this lot is rejected and shall not be supplied to the specification.

4.6.4.3 PPM calculations. PPM calculations shall be based on the accumulated results of the initial sample. Calculations and exclusions shall be in accordance with EIA-554-1. (NOTE: PPM calculations shall not be based on the second sample submission for a rejected lot as described in 4.6.4.2).

MIL-PRF-55182G

TABLE XII. Group A inspection (ER and space level only).

Inspection	Requirement paragraph	Method paragraph	Sampling procedure
<u>Subgroup 1</u>			
Thermal shock <u>1/ 5/</u>	3.8	4.8.2	100% inspection
Overload <u>1/</u>	3.9	4.8.3	
Power conditioning (space level only)	3.10	4.8.4	
Hermetic seal (when applicable) <u>2/</u>	3.12	4.8.6	
DC resistance <u>3/</u>	3.11	4.8.5	
Resistance noise (space level only)	3.30	4.8.24	
<u>Subgroup 2</u>			
Visual and mechanical examination <u>4/</u>	3.5	4.8.1	See table XIII
<u>Subgroup 3</u>			
Solderability <u>6/</u>	3.13	4.8.7	See 4.6.3.2.4
<u>Subgroup 4 (space level only)</u>			
Destructive physical analysis	3.31	4.8.25	See 4.6.3.2.5

- 1/ At the manufacturer's option, the determination of resistance change may be any method which is within the accuracy requirements of this specification.
- 2/ Hermetic seal test applicable to characteristic C and characteristic E.
- 3/ Resistors shall meet the specified initial resistance tolerance after being subjected to the preceding tests. The resistance measurement made upon completion of the overload test may be used if a measurement has been made which can, with conversion, be directly related to nominal resistance value and tolerance.
- 4/ At the manufacturer's option, marking inspection may be performed after group B inspection; however, if this is done, no defects shall be permitted. Marking shall remain legible at the end of all tests.
- 5/ If the manufacturer can demonstrate that the FR level of the parts can be maintained without performing the thermal shock screen, this test, with approval of the preparing activity and qualifying activity, may be deleted. If the design, material, construction, or processing of the part is changed, or if there are any quality problems or failures, the qualifying activity may require resumption of the test. As a minimum, for initial consideration of this option, the manufacturer shall demonstrate and validate using data equivalent to M FR qualification, that the test does not affect the FR of the resistor. (NOTE: This option is not available on RNC90). Upon deletion of the test, the manufacturer must continue to maintain their existing FR level based on testing of parts without the thermal shock screening.
- 6/ The manufacturer may request the deletion of the subgroup 3 solderability test, provided an in-line or process control system for assessing and assuring the solderability of leads can be validated and approved by the qualifying activity. Deletion of the test does not relieve the manufacturer from meeting this test requirement in case of dispute. If the design, material, construction, or processing of the part is changed or if there are any quality problems, the qualifying activity may require resumption of the test.

MIL-PRF-55182G

TABLE XIII. Sampling plan for subgroup 2 and PPM-2 categories.

Lot size	Sample size subgroup 2	Sample size PPM-2
1 - 13	100%	100%
14 - 125	13	100%
126 - 150	13	125
151 - 280	20	125
281 - 500	29	125
501 - 1,200	34	125
1,201 - 3,200	42	125
3,201 - 10,000	50	125
10,001 - 35,000	60	294
35,001 - 150,000	74	294
150,001 - 500,000	90	345
500,001 and over	102	435

TABLE XIV. Solderability sample plan.

Lot size	Sample size
1 to 3,200	5
3,201 to 10,000	8
10,001 to 35,000	13
35,001 and over	20

4.6.5 Group B inspection (ER and space level only). Group B inspection shall consist of the inspections and tests specified in table XV, in the order shown. They shall be performed on samples from lots which have been subjected to and have passed the group A inspection.

4.6.5.1 Sampling plan. All qualified styles (except RNC90) may be grouped together in a single sample. This can be accomplished by proportion based on manufacturing percentages by style, equally divided by style or by establishing an alternating style sequence. In order to incorporate a style sampling grouping, a written description must be presented and approved by the qualifying activity. This plan must assure that the grouping only combines styles of the same basic design, encapsulation material, and the same element type. Characteristics may be combined and grouped together. In order to group characteristics together they must be of the same basic design and element type. Characteristics that cover other characteristics shall be as specified in table X.

4.6.5.1.1 Subgroup 1. A sample of 13 parts shall then be randomly selected. If one or more defects are found, the lot shall be rescreened and defects removed. If one or more defects are found, a new sample of 13 parts shall then be randomly selected. If one or more defects are found in the second sample, the lot shall be rejected and shall not be supplied to this specification.

4.6.5.1.2 Subgroup 2. A sample of 13 parts shall then be randomly selected. If one or more defects are found, the lot shall be rescreened and defects removed. If one or more defects are found, a new sample of 13 parts shall then be randomly selected. If one or more defects are found in the second sample, the lot shall be rejected and shall not be supplied to this specification.

MIL-PRF-55182G

4.6.5.1.3 Subgroup 3. A total of 8 samples shall be selected and submitted to the test specified in subgroup 3. If one or more defects are found, the manufacturer may rework the lot to correct defects or screen out the defective units. A new sample of 8 additional units shall then be subjected to this test. If one or more defects are found in the second sample, the lot shall be rejected and shall not be supplied to this specification.

TABLE XV. Group B inspection.

Inspection	Requirement paragraph	Method paragraph	Number samples
<u>Subgroup 1</u> <u>1/</u> Resistance temperature characteristic	3.15	4.8.9	13
<u>Subgroup 2</u> <u>1/</u> Visual and mechanical examination (when applicable) <u>2/</u>	3.1 and 3.34	4.8.1	13
<u>Subgroup 3</u> <u>1/</u> Resistance to solvents	3.14	4.8.8	8

1/ If the manufacturer can demonstrate that this test has been performed five consecutive times with zero failures, the frequency of this test, with the approval of the qualifying activity, can be performed on an annual basis. If the design, material, construction or processing of the part is changed, or if there are any quality problems or failures, the qualifying activity may require resumption of the original test frequency.

2/ Only applicable when marking inspection is not performed in group A inspection. No defects shall be permitted. Marking shall remain legible at the end of all tests.

4.6.5.2 Disposition of sample units. Sample units which have been subjected to group B, subgroup 1 and subgroup 2 inspections may be delivered on the contract provided they are within resistance tolerance and meet requirements for visual and mechanical inspection. Sample units which have been subjected to subgroup 3 inspections shall not be delivered on the contract.

4.7 Periodic group C inspection (ER only). Group C inspection shall consist of the inspections as specified in table XVI, in the order shown, and shall be performed on sample units of each style and characteristic produced during the inspection period covered and shall be selected from lots that have passed group A and group B inspections. The allowable number of defects shall be as indicated in table XVI.

MIL-PRF-55182G

TABLE XVI. Group C inspection. 1/

Test	Requirement paragraph	Method paragraph	Number of samples	Number of defects allowed
<u>Monthly</u> <u>Subgroup 1</u>				
Life	3.24	4.8.18	See 4.7.1.1	See 4.7.1.1
<u>Subgroup 2</u>				
Resistance to soldering heat	3.20	4.8.14	50	<u>2/</u> 1
Moisture resistance	3.21	4.8.15		
<u>Subgroup 3</u> <u>3/</u>				
Dielectric withstanding voltage	3.18	4.8.12	30	1
Insulation resistance	3.19	4.8.13		
Low temperature storage	3.29	4.8.23		
Low temperature operation	3.16	4.8.10		
Terminal strength	3.17	4.8.11		
Hermetic seal (when applicable)	3.12	4.8.6		
<u>Quarterly</u> <u>3/</u>				
Shock (specified pulse)	3.22	4.8.16	30	1
Vibration, high frequency	3.23	4.8.17		
Hermetic seal (when applicable)	3.12	4.8.6		
<u>Semiannually</u> <u>4/</u>				
High temperature exposure	3.25	4.8.19	<u>5/</u> 102	1

1/Marking shall remain legible at the end of all tests.

2/For characteristic C and characteristic E, zero failures are permitted in moisture resistance.

3/If the manufacturer can demonstrate that these tests have been performed five consecutive times with zero failures, these tests, with the approval of the qualifying activity, can be deleted. The manufacturer, however, shall perform these tests every 3 years after the deletion as part of long term design verification. If the design, material, construction or processing of the part is changed, or if there are any quality problems, the qualifying activity may require resumption of the specified testing. Deletion of testing does not relieve the manufacturer from meeting the test requirements in case of dispute.

4/If the manufacturer can demonstrate that this test has been performed five consecutive times with zero failures, the frequency of this test, with the approval of the qualifying activity, can be performed on an annual basis. If the design, material, construction, or processing of the part is changed, or if there are any quality problems or failures, the qualifying activity may require resumption of the original test frequency.

5/Ten sample units shall be subjected to dielectric withstanding voltage and insulation resistance following test.

MIL-PRF-55182G

4.7.1 Sampling plan. If more than 1,000 resistors of any style or style grouping are produced over the maintenance period, the group C tests shall be performed as specified. If the production rate is less than 1,000 resistors for any style or style grouping over the maintenance period, then the monthly, quarterly, or semi-annual group C inspection may be postponed until at least 1,000 resistors of that style or grouping are produced (except for the monthly life test). In any case, the monthly tests shall be performed at least once every 3 months. The quarterly tests shall be performed at least every 6 months and the semi-annual tests shall be performed at least once every year. This requirement is waived if the manufacturer has obtained a reduced inspection status through the qualifying activity.

All qualified styles (except RNC90) may be grouped together in a single sample. This can be accomplished by proportion based on manufacturing percentages by style, equally divided by style, or by establishing an alternating style sequence. In order to incorporate a style sampling grouping, a written description must be presented and approved by the qualifying activity. This plan must assure that the grouping only combines styles of the same basic design, encapsulation material, and the same element type.

Characteristics may be combined and grouped together. In order to group characteristics together they must be of the same basic design and element type. Characteristics that cover other characteristics shall be as specified in table X.

4.7.1.1 Monthly (subgroup 1). Samples shall be accumulated from each inspection lot and placed on extended life test of 4.8.18 once a month for the full 10,000 hour life test. A sufficient number of samples shall be selected from each lot by the manufacturer so that the maintenance of FR requirements are complied with the specified maintenance period. In any event, a minimum of five samples shall be selected from each lot. As far as is practical, the manufacturer shall select the resistance values so that all resistance decades produced during the maintenance period are represented.

4.7.1.2 Monthly (subgroup 2). Each month the tests specified in subgroup II shall be performed on 50 sample units of each style and characteristic on resistance values in the highest decade produced. The samples selected from the highest decade shall be representative of the decade, and the month's production samples selected shall not be from low value end of decade of values chosen.

4.7.1.3 Monthly (subgroup 3). Each month 15 sample units of any resistance value below critical and 15 sample units of any resistance value above critical of each style and characteristic shall be subjected to the tests of subgroup 3, in the order shown.

4.7.1.4 Quarterly. Every 3 months 30 sample units of each style and characteristic and of any resistance value shall be subjected to the tests specified in table XVI, in the order shown.

4.7.1.5 Semiannually. One hundred and two sample units divided equally among the nearest to the lowest, critical, and highest resistance values during the 6 month period shall be subjected to the semiannual inspection of table XVI. In addition, 10 sample units of highest value produced during the 6 month period shall be subjected to the mechanical shear test.

4.7.2 Disposition of samples. Sample units which have been subjected to group C inspection shall not be delivered on the contract or order.

4.7.3 Noncompliance. If a sample fails to pass group C inspection, the manufacturer shall immediately notify the qualifying activity and cognizant inspection activity of such failure and take corrective action on the materials or processes, or both, as warranted, and on all units of product which can be corrected and which are considered subject to the same failure. Acceptance and shipment of the product shall be discontinued until corrective action, acceptable to the qualifying activity has been taken. After the corrective action has been taken, group C inspection shall be repeated on additional sample units (all of the inspection, or the inspection which the original sample failed, at the option of the qualifying activity). Group A and group B inspection may be reinstated; however, final acceptance and shipment shall be withheld until the group C inspection has shown that the corrective action was successful.

MIL-PRF-55182G

4.8 Methods of examination and tests.

4.8.1 Visual and mechanical examination. Resistors shall be examined to verify that the materials, design, construction, physical dimensions, marking, and workmanship are in accordance with the applicable requirements (see 3.1, 3.3, 3.4, 3.5.1.1 through 3.5.3.2 inclusive, 3.5.5, 3.31, 3.34, and 3.34.1).

4.8.2 Thermal shock (see 3.8). Resistors shall be tested in accordance with method 107 of MIL-STD-202. The following details and exceptions shall apply:

a. Special mounting:

- (1) Qualification inspection: Resistor shall be mounted by means other than soldering.
- (2) Conformance inspection: Resistors shall be mounted by means other than soldering or may be placed in trays. When trays are used, they must be designed to present a minimum obstruction to the airstream. In no case shall the fixture prevent the specified ambient temperature from being achieved within 4 minutes after resistors are placed in chamber. One chamber may be used for this test.

b. Measurement before cycling: DC resistance shall be measured as specified in 4.8.5.

c. Test condition:

- (1) Qualification inspection: Test condition F (5 cycles), except that the extreme high temperature shall be +150°C, +3°C, -0°C. For the group VII (space level only) test: Test condition F-3 (100 cycles) except that the extreme high temperature shall be +150°C, +3°C, -0°C.
- (2) Conformance inspection: Test condition F, except that the extreme high temperature shall be +150°C, +10°C, -0°C and the extreme low temperature shall be -65°C, +0°C, -10°C. These extreme temperatures shall be achieved within 4 minutes.

d. Measurement after cycling: DC resistance shall again be measured as specified in 4.8.5 following test of 4.8.3.

e. Examination after test: Resistors shall be examined for evidence of mechanical damage.

4.8.3 Overload (see 3.9).4.8.3.1 Mounting.

4.8.3.1.1 Qualification inspection. Resistors shall be mounted horizontally in free space with no object closer than 3 inches below the resistors, except the mounting base, which shall be no closer than 2 inches below the resistors. They shall be mounted in still air, with no circulation other than that caused by the heat of the resistors being operated.

4.8.3.1.2 Conformance inspection. Resistors may be mounted in any position and allotted any size space as deemed necessary by the manufacturer. Forced air cooling may be used to maintain a test ambient temperature range of +20°C to +50°C. The average velocity of the forced air, if employed, shall not exceed 500 feet per minute.

4.8.3.2 Procedure. Table XVII lists the load which shall be applied, its duration, and the maximum voltage, alternating current (ac) or dc, which may be applied to the applicable resistor style. Resistance as specified in 4.8.5 shall be measured following the tests, and compared with reading taken prior to test of 4.8.2. Resistors shall be examined for evidence of arcing, burning, or charring.

MIL-PRF-55182G

TABLE XVII. Overload.

Resistor style <u>1/</u>	Overload and duration	Maximum voltage (ac or dc)
RNR50, RNR55, RNR57, RNR60	5 x rated power for 1 hour	<u>Volts</u> 500
RNR65	4 x rated power for 1 hour	600
RNR70	2.25 x rated power for 1 hour	700
RNR75	2.25 x rated power fro 1 hour	1,000
RNR77	1.25 x rated power for 1 hour	1,000

1/ Third letter is variable, dependent upon lead material or capacity.

4.8.4 Power conditioning (space level only) (see 3.10). Resistors shall be tested in accordance with method 108 of MIL-STD-202. The following details and exceptions shall apply: Resistors shall be mounted as in 4.8.3 for conformance inspection. The load applied shall be full rated power for a duration of 100 hours ± 4 hours, and at a test temperature of $125^{\circ}\text{C} \pm 3^{\circ}\text{C}$. The maximum voltage shall be as specified (see 3.1). The voltage applied may be dc or ac. DC resistance as specified in 4.8.5 shall be measured before the test and after the test following a two hour stabilization period of $25^{\circ}\text{C} \pm 2^{\circ}\text{C}$. Resistors shall be visually examined for any evidence of mechanical damage.

4.8.5 DC resistance (see 3.11). Resistors shall be tested in accordance with method 303 of MIL-STD-202. The following details and exceptions shall apply:

- a. Measuring apparatus: Different types of measuring test equipment (multimeters, bridges, or equivalent) are permitted to be used on the initial and final readings of this test, provided the equipment is the same type, model, or if it can be shown that the performance of the equipment is equivalent or better.
- b. Limit of error of measuring apparatus: $\pm(0.1 \text{ percent} + 0.1 \text{ ohm})$, but not exceeding one-fourth of the resistor tolerance or the resistance change limit for which the measurement is being made. Manufacturers, at their option, may use apparatus of less accuracy, provided that limits are reduced to fully compensate for accuracy deviation.
- c. Test voltage for bridges: Measurements of resistance shall be made by using the test voltages as specified in table XVIII. The test voltage chosen, whether it be the maximum voltage or a lower voltage which would still provide the sensitivity required, shall be applied across the terminals of the resistor. This same voltage shall be used whenever a subsequent resistance measurement is made.
- d. Temperature: Unless otherwise specified herein, the temperature at which subsequent and final resistance measurements are made in each test shall be within $\pm 2^{\circ}\text{C}$ of the temperature at which the initial measurement was made.

MIL-PRF-55182G

TABLE XVIII. DC resistance test voltages.

Resistance, nominal	Maximum test voltage	
	1/2 watt	1/20 watt, 1/10 watt, 1/8 watt, and 1/4 watt
<u>Ohms</u>	<u>Volts</u>	<u>Volts</u>
10 to 98 inclusive	1	1
100 to 980 inclusive	3	3
1,000 to 9,800 inclusive	10	3
10,000 to 98,000 inclusive	30	10
0.1 megohm or higher	100	30

4.8.6 Hermetic seal (applicable to characteristic C and characteristic E) (see 3.12). Resistors shall be tested in accordance with method 112 of MIL-STD-202 and method 1014 of MIL-STD-883. The following details and exceptions shall apply:

- a. For qualification inspection (except group I) and group C inspection: Test condition C, procedure III or procedure IV of method 112, MIL-STD-202 shall be used (procedure IV will be used as a referee in the event of disagreement), except gross leak test shall be in accordance with 4.8.6b. The coating (organic or nonorganic) may be removed prior to testing.
- b. Group I qualification inspection and group A inspection: Method 1014 of MIL-STD-883, condition D .
 - (1) For transparent envelopes, the chamber shall be evacuated to 28 inches to 30 inches of mercury gauge pressure for a minimum of 2 minutes prior to pressurization. The mixing of dye solution with hydraulic fluid is permissible when such fluids are used to achieve chamber pressure above 1,000 psi.
 - (2) For nontransparent envelopes, the chamber shall be evacuated as above. After pressurization, resistors shall be thoroughly cleansed of external dye and then rotated about their longitudinal axis for a minimum of 2 minutes at a minimum ambient temperature of +80°C. Following rotation, resistors shall be examined for evidence of dye leakage.

4.8.7 Solderability (applicable to solderable, solderable/weldable terminals only) (see 3.13). Resistors shall be tested in accordance with method 208 of MIL-STD-202. The following detail shall apply: Both leads shall be tested.

4.8.8 Resistance to solvents (see 3.14). Resistors shall be tested in accordance with method 215 of MIL-STD-202. The following details shall apply:

- a. The marked portion of the resistor body shall be brushed.
- b. The number of sample units shall be as specified in table XI and table XV, as applicable.
- c. Resistors shall be examined for mechanical damage and legibility of marking.

MIL-PRF-55182G

4.8.9 Resistance-temperature characteristics (see 3.15). Resistors shall be tested in accordance with method 304 of MIL-STD-202. The following details and exceptions shall apply:

- a. Reference temperature: Room ambient temperature.
- b. Test temperature: In accordance with table XIX.
- c. Accuracy of temperature measurement: Resistors shall be maintained for 30 minutes to 45 minutes within $+1^{\circ}\text{C}$ at each of the test temperatures listed in table XIX. This tolerance shall be maintained at the established test temperatures.
- d. As an option, the manufacturer may develop a control procedure for minimum stabilization times required for RTC testing. This procedure shall detail specific time elements required to reach thermal and electrical stability for specific part designs. Upon approval by the qualifying activity, the manufacturer may use this procedure for minimum stabilization times for RTC testing.

TABLE XIX. Resistance temperature characteristic.

Sequence	Temperature ($^{\circ}\text{C}$)	
	Qualification inspection ($^{\circ}\text{C} \pm 3$)	Group B inspection <u>1/</u> ($^{\circ}\text{C} \pm 3$)
1	25 <u>2/</u>	25 <u>2/</u>
2	-15	-55
3	-55	25 <u>2/</u>
4	25 <u>2/</u>	N/A
5	65	175
6	125 <u>3/</u>	N/A
7	175	N/A

1/ At the option of the manufacturer, the reverse sequence may be as follows:

- 1 - 25
- 2 - 175
- 3 - 25
- 4 - -55

2/ This temperature shall be considered the reference temperature for each of the succeeding temperatures.

3/ Applicable to characteristic Y of MIL-R-55182/9 only (see 3.1).

4.8.10 Low temperature operation (see 3.16).

4.8.10.1 Mounting. Resistors shall be mounted by their terminals so that there is at least 1 inch of free air space around each resistor. The mounting is in such a position with respect to the air that it offers substantially no obstruction to the flow of air across and around the resistors.

4.8.10.2 Procedure. Following a dc resistance measurement, the resistors, mounted as specified in 4.8.10.1, shall be placed in a cold chamber at room temperature. The temperature shall be gradually decreased to -65°C $+0^{\circ}\text{C}$ -5°C , within a period of not less than 1 hour 30 minutes. For group C inspection only, and at the option of the manufacturer, the resistors may be placed in the cold chamber when the chamber is already at the extreme low temperature. After 1 hour of stabilization at this temperature, full rated continuous working voltage as specified in 3.7 shall be applied for 45 minutes. The resistors may be loaded individually or in parallel. Fifteen minutes $+5$ minutes -0 minutes after the removal of voltage, the temperature in the chamber shall be gradually increased to room temperature within a period of not more than 8 hours. The resistors shall be removed from the chamber and maintained at a temperature of $+25^{\circ}\text{C} \pm 5^{\circ}\text{C}$ for a period of approximately 24 hours. The dc resistance shall then be measured as specified in 4.8.5. Resistors shall then be examined for evidence of mechanical damage.

MIL-PRF-55182G

4.8.11 Terminal strength (see 3.17). Resistors shall be tested in accordance with method 211 of MIL-STD-202 with following exceptions:

- a. Test condition: A (pull test) and D (twist test), respectively.
- b. Measurement before test, condition A: DC resistance shall be as specified in 4.8.5.
- c. Method of holding, condition A: Resistors shall be clamped by one terminal lead.
- d. Applied force, condition A: Two pounds for styles RNR50, RNR55, RNR60, and RNR65; 4.5 pounds for style RNR70; and 5 pounds for styles RNR75, and RNR77. ^{1/}
- e. Measurement after test, condition D: DC resistance shall be as specified in 4.8.5, and examined for evidence of breaking and loosening of terminals and chipping of coating.

4.8.12 Dielectric withstanding voltage (see 3.18).

4.8.12.1 Atmospheric pressure. Resistors shall be tested in accordance with method 301 of MIL-STD-202. The following details and exceptions shall apply:

- a. Special preparations: Resistors shall be placed in a conductive material which will conform to the resistor surface so that between 90 and 100 percent of the outer periphery is contacted. The conductive material shall be centered on the resistor body. Care should be taken that any part of the resistor lead is as far away from the conductive material as possible.
- b. Initial measurement: DC resistance shall be measured as specified in 4.8.5.
- c. Magnitude of test voltage: Sine wave test potential of 900 volts rms, except that for styles RNR50, RNR55, RNR57, and RNR60, the potential shall be 450 volts. ^{1/}
- d. Nature of potential: An ac supply at commercial line frequency (not more than 100 hertz (Hz)) and waveform.
- e. Rate of application of test voltage: 100 volts per second.
- f. Duration of application of test voltage: 1 minute.
- g. Points of application of test voltage: Between the resistor terminals connected together and the conductive material. (No longer mounted in a V-block)
- h. Measurement after test: DC resistance shall be measured as specified in 4.8.5.

^{1/} Third letter is variable, dependent upon lead material or capability.

- i. Examination after test: Resistors shall be examined for evidence of flashover, mechanical damage, arcing, and insulation breakdown.

MIL-PRF-55182G

4.8.12.2 Barometric pressure (reduced). Resistors shall be tested in accordance with method 105 of MIL-STD-202. The following details and exceptions shall apply:

- a. Method of mounting: As specified in 4.8.12.1a.
- b. Initial measurement: DC resistance shall be measured as specified in 4.8.5.
- c. Test condition: D (100,000 feet).
- d. Test voltage during subjection to reduced pressure: 300 volts rms, except for styles RNR50, RNR55, RNR57, and RNR60 the potential shall be 200 volts. For style RNR75 and RNR77 the potential shall be 450 volts. 2/
- e. Nature of potential: As specified in 4.8.12.1d.
- f. Duration of test: 1 minute.
- g. Points of application: As specified in 4.7.11.1g.
- h. Final measurement: DC resistance shall be measured as specified in 4.8.5.
- i. Examinations after test: As specified in 4.8.12.1i.

4.8.13 Insulation resistance (see 3.19). Resistors shall be tested in accordance with method 302 of MIL-STD-202. The following details and exceptions shall apply:

- a. Test condition: A (100 volts $\pm 10\%$).
- b. Special preparations: As specified in 4.8.12.1a.
- c. Points of measurements: Between the resistor terminals connected together and the conductive material.

4.8.14 Resistance to soldering heat (see 3.20). Resistors shall be tested in accordance with method 210 of MIL-STD-202. The following details and exceptions shall apply:

- a. Measurement before test: DC resistance shall be measured as specified in 4.8.5.
- b. Special preparation of specimen: Both leads shall be dipped in flux and then dipped into solder, both for 5 seconds $\pm 1/2$ second. The bath shall be maintained at $+260^{\circ}\text{C} \pm 5^{\circ}\text{C}$. The parts shall be immersed to within .075 inch $\pm .025$ inch from the resistor body. For RNC90 the part shall be immersed .075 inch from where lead exits the body.
- c. Test condition: C ($+260^{\circ}\text{C} \pm 5^{\circ}\text{C}$, 10 seconds ± 2 seconds). A board with a maximum area of nine square inches shall be used, and the leads shall not be cut.
- d. Measurement after test: After completion of cleaning process and following a minimum 3 hour cooling period, dc resistance shall be measured as specified in 4.8.5.
- e. Examination after test: Resistors shall be examined for evidence of mechanical damage.

2/ Third letter is variable, dependent upon lead material or capability.

MIL-PRF-55182G

4.8.15 Moisture resistance (see 3.21). Resistors shall be tested in accordance with method 106 of MIL-STD-202. The following details and exceptions shall apply:

- a. Mounting: Soldered by their leads to rigid mounts or terminal lugs. The spacing of the mounts or terminal lugs shall be such that the length of each resistor lead is approximately three-eighths of an inch when measured from the edge of the supporting terminal to the resistor body. Resistor leads may be formed, if necessary, so as to not compromise the seal of the resistor. One half of the sample units shall be covered with a V-shaped metal strap whose width is equal to that of the resistor body as indicated in figure 3. The strap shall be made from corrosion-resistant metal and shall be kept in contact with the resistor body by supporting the body as indicated in figure 3, with a nonconducting, noncorrosive support whose width is less than that of the resistor body and which will not act as a moisture trap. The mounting straps may be individual for each resistor or continuous for all resistors.
- b. Initial measurement: Immediately following the initial drying period, dc resistance shall be measured as specified in 4.8.5.
- c. Polarization and loading voltage: The resistance value selected shall be divided equally as possible for polarization and load.
 - (1) Polarization voltage: During steps 1 through 6, a 100 volt dc potential shall be applied only to those resistors which have a polarizing strap. This potential shall be applied with the positive lead connected to the resistor terminals tied together, and the negative lead connected to the polarizing straps.
 - (2) Loading voltage: During the first 2 hours of step 1 and step 4, a dc test potential equivalent to 100 percent rated wattage, but not exceeding the maximum rated voltage shall be applied to those resistors which do not have the polarizing strap specified in 4.8.15a.
- d. Subcycle: Step 7b shall not be applicable. Step 7a shall be performed during any five of the first nine cycles only. All polarizing straps may be removed to perform step 7a and shall then be replaced prior to returning the resistors to the humidity chamber.
- e. Final measurements: Upon completion of step 6 of the final cycle, the resistors shall be held at the high humidity conditions and at a temperature of $+25^{\circ}\text{C} \pm 2^{\circ}\text{C}$ for a period of 1 hour 30 minutes to 3 hours 30 minutes. The same straps used for polarizing the resistors may also be used for the dielectric withstanding voltage test and insulation resistance tests. Resistors shall be removed from the chamber and within 30 minutes without any additional handling, the dc resistance, the dielectric withstanding voltage, and insulation resistance shall be measured in that order as specified in 4.8.5, 4.8.12.1, and 4.8.13 respectively.
- f. Examination after test: Resistors shall be examined for evidence of mechanical damage.

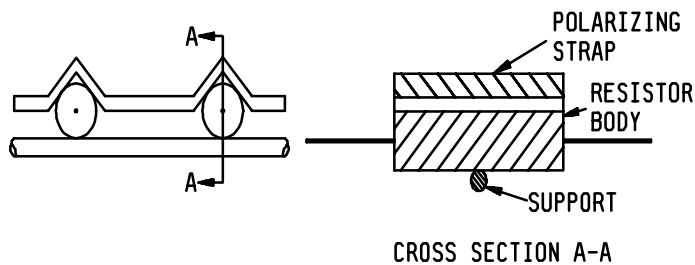

FIGURE 3. Mounting straps for moisture-resistance test.

4.8.16 Shock (specified pulse) (see 3.22). Resistors shall be tested in accordance with method 213 of

MIL-PRF-55182G

MIL-STD-202. The following details and exceptions shall apply:

- a. Special mounting means: Resistors shall be rigidly mounted on appropriate jig fixtures with their leads supported at a distance of one-fourth of an inch from the resistor body. The resistor shall be mounted with the body clamped or cemented to a flat surface. Where used, the cement material shall not extend above the center line in a vertical plane or beyond the resistor body ends in a horizontal plane. In no case shall the resistor body be completely encapsulated (see figure 4). These fixtures shall be constructed in a manner to insure that the points of the resistor mounting supports will have the same motion as the shock table. Test leads used during this test shall be no larger than AWG size 22 stranded wire, so that the influence of the test lead on the resistor will be held to a minimum. The test lead length shall be no greater than necessary. In all cases, the resistors shall be mounted in relation to the test equipment in such a manner that the stress applied is in the direction which would be considered most detrimental.
- b. Measurement before shock: DC resistance shall be measured as specified in 4.8.5.
- c. Number and direction of applied shocks: The resistors shall be subjected to a total of ten shocks in each of two mutually perpendicular planes, one perpendicular and the other parallel to the longitudinal axis of the resistor.
- d. Test condition: I (100 G, 6 milliseconds (ms) sawtooth).
- e. Measurement during shock: Each resistor shall be monitored to determine electrical discontinuity by a method which shall at least be sensitive enough to monitor or register, automatically, any electrical discontinuity of 0.1 ms or greater duration.
- f. Measurement after shock: DC resistance shall be measured as specified in 4.8.5.
- g. Examination after test: Resistors shall be examined for evidence of mechanical and electrical damage.

4.8.17 Vibration, high frequency (see 3.23). Resistors shall be tested in accordance with method 204 of MIL-STD-202. The following details and exceptions shall apply:

- a. Mounting of specimens: Resistors shall be mounted on appropriate jig fixtures as specified in 4.8.16a. These fixtures shall be constructed in a manner to insure that the points of the resistor mounting supports will have the same motion as the vibration test table. The fixtures shall also be of a construction that will preclude any resonance in the fixture when subjected to vibration within the test frequency range, and the fixture shall be monitored for these features on the vibration table. Test leads used during this test shall be no larger than AWG size 22 stranded wire, so that the influence of the test lead on the resistor will be held to a minimum. The test lead length shall be no greater than is necessary. A shielded cable, which may be necessary because of the field surrounding the vibration table, shall be clamped to the resistor mounting jig.
- b. Initial measurement: DC resistance shall be measured as specified in 4.8.5.
- c. Test condition: D (10 Hz to 2,000 Hz, 20 G).
- d. Direction of motion: In each of two mutually perpendicular directions, one perpendicular and the other parallel to the longitudinal axis of the resistor. Duration shall be 4 hours in each plane with total test time of 8 hours.
- e. Measurements during vibration: Each resistor shall be monitored to determine electrical discontinuity by a method which shall at least be sensitive enough to monitor or register, automatically, any electrical discontinuity of 0.1 ms or greater duration.
- f. Measurement after vibration: DC resistance shall be measured as specified in 4.8.5.
- g. Examination after test: Resistors shall be examined for evidence of mechanical damage.

4.8.18 Life (see 3.24). Resistors shall be tested in accordance with method 108 of MIL-STD-202. The following

MIL-PRF-55182G

details and exceptions shall apply:

- a. Method of mounting: Resistors shall be mounted on light weight terminals (see figure 5). The effective length of each terminal shall be 1 inch for qualification inspection and one-half inch, minimum, for group C inspection. Resistors shall be soldered to the terminals, except that for group C inspection, this will be at the option of the manufacturer. Resistors shall be so arranged that the temperature of any one resistor will not appreciably influence the temperature of any other resistor.
- b. Test temperature:
 - (1) Qualification inspection: $+125^{\circ}\text{C} \pm 5^{\circ}\text{C}$.
 $+70^{\circ}\text{C}$ power rating: $+70^{\circ}\text{C} \pm 5^{\circ}\text{C}$.
 - (2) FR level determination $+125^{\circ}\text{C}$, $+15^{\circ}\text{C}$, -5°C .
- c. Initial resistance measurement: Measurements may be made inside or outside the chamber.
 - (1) Inside the chamber: When measurements are to be made inside the chamber, the initial dc resistance shall be measured after mounting at the applicable test temperature, after stabilization, and within 8 hours of exposure of the resistors to the test temperature. This initial measurement shall be used as the reference temperature for all subsequent measurements under the same condition.
 - (2) Outside the chamber: When measurements are to be made outside the chamber, the initial dc resistance shall be measured after mounting at the room temperature. This initial measurement shall be used as the reference temperature for all subsequent measurements under the same condition.
- d. Operating conditions: Rated dc continuous working voltage or filtered or nonfiltered full-wave rectified ac voltage shall be applied intermittently, 1 hour 30 minutes on and 30 minutes off, for the applicable number of hours (see 4.8.18f) and at applicable test temperature. During the "on" cycle, the voltage shall be regulated and controlled to maintain ± 5 percent of the rated continuous working voltage.
- e. Test condition: 2,000 hours elapsed time for qualification inspection with all samples continued to 10,000 hours; 2,000 hours for $+70^{\circ}\text{C}$ power rating test; 10,000 hours for FR level inspection group C.
- f. Measurements during test:
 - (1) Qualification inspection: DC resistance shall be measured at the end of the 30 minutes off periods after 250 hours +72 hours -24 hours, 500 hours +72 hours -24 hours, 1,000 hours +72 hours -24 hours, and 2,000 hours +96 hours -24 hours have elapsed.
 - (2) Extended life testing: DC resistance shall be measured at the end of the 30 minutes off periods after 250 hours +72 hours -24 hours, 500 hours +72 hours -24 hours, 1,000 hours +72 hours -24 hours, and 2,000 hours +96 hours -24 hours, and every 2,000 hours +96 hours -24 hours thereafter until the required 10,000 hours +120 hours -0 hours has elapsed. Measurements shall be made as near as possible to the specified time but may be adjusted so that measurements need not be made during other than normal workdays.
 - (3) Measurements outside of the chamber: When measurements are made outside the chamber, resistors shall be outside of the chamber for a minimum of 45 minutes and stabilized at room temperature before measurement.
- g. Examination after test: Resistors shall be examined for evidence of mechanical damage.

MIL-PRF-55182G

4.8.19 High temperature exposure (see 3.25).

- a. Mounting: Resistors shall be mounted by their normal mounting means.
- b. Initial measurements: DC resistance shall be measured as specified in 4.8.5 at room ambient conditions.
- c. Procedure: Following initial resistance measurements, resistors shall be placed in a chamber maintained at +175°C +5°C -0°C for a period of 2,000 hours +72 hours -0 hours with no load applied.
- d. Measurements during test: 250 hours +48 hours -0 hours.
- e. Final measurements: After removal from test chamber, resistors shall be permitted to stabilize at room ambient temperature and within 6 hours after removal, dielectric withstanding voltage, insulation resistance, and dc resistance shall be measured as specified in 4.8.5, 4.8.12, and 4.8.13, respectively. Resistors shall be examined for evidence of mechanical damage.

4.8.20 Voltage coefficient (applicable to resistors of 1,000 ohms and over) (see 3.26). Resistors shall be tested in accordance with method 309 of MIL-STD-202. The continuous working voltage shall be as specified in the applicable associated specification (see 3.1).

4.8.21 Fungus (see 3.27). Resistors shall be tested in accordance with method 508 of MIL-STD-810. Resistors shall be examined for evidence of mechanical damage.

4.8.22 Mechanical shear (when applicable, see 3.1 and 3.28). When specified (see 3.1), resistors shall be tested in accordance with the following procedures:

- a. Initial measurement: DC resistance shall be measured as specified in 4.8.5.
- b. Mounting: Resistors shall be mounted in test fixture as specified on figure 6.
- c. Applied force: The force of 8 pounds shall be applied at a steadily increasing rate, so that the 8 pounds is applied between 10 seconds to 30 seconds and the 8 pounds is maintained a minimum of 10 seconds.
- d. Measurement during test: None.
- e. Final measurements: DC resistance shall be measured as specified in 4.8.5. Resistors shall be examined for deformation and mechanical damage.

MIL-PRF-55182G

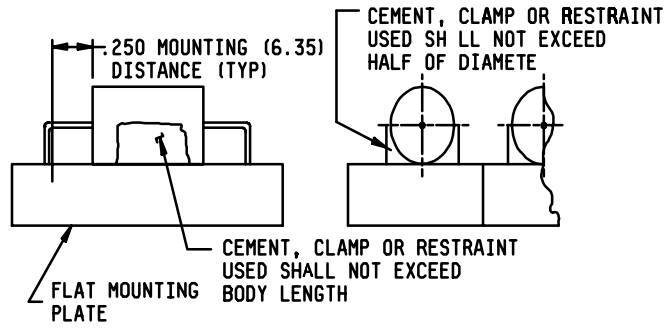

NOTES:

1. Dimensions are in inches.
2. Metric equivalents are given for general information only.
3. Metric equivalents are in parentheses.
4. Following test, resistor(s) shall be unmounted and examined for mechanical and electrical damage.

FIGURE 4. Mounting means for shock and high frequency vibration tests.

MIL-PRF-55182G

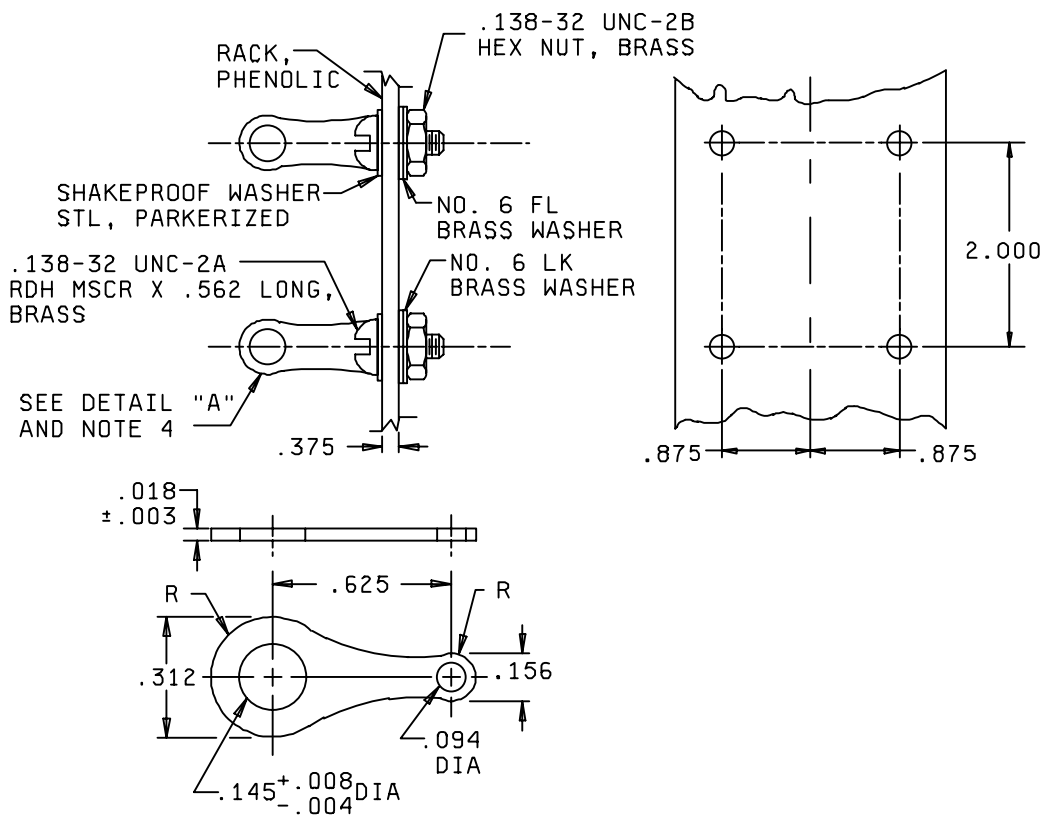

Inches	mm	Inches	mm	Inches	mm
.003	0.08	.138	3.50	.502	14.27
.004	0.10	.145	3.68	.625	15.88
.008	0.20	.156	3.96	.875	22.23
.018	0.46	.312	7.92	2.000	50.80
.094	2.39	.375	9.53		

NOTES:

1. Dimensions are in inches.
2. Metric equivalents are given for general information only.
3. Unless otherwise specified, tolerance shall be ±.015 inch (0.38 mm).
4. Solder lug, tinned brass, in accordance with catalog number 2441; Cinch Manufacturing Corporation, Chicago, IL, or equal.

FIGURE 5. Suggested mounting-lug arrangement for life test.

MIL-PRF-55182G

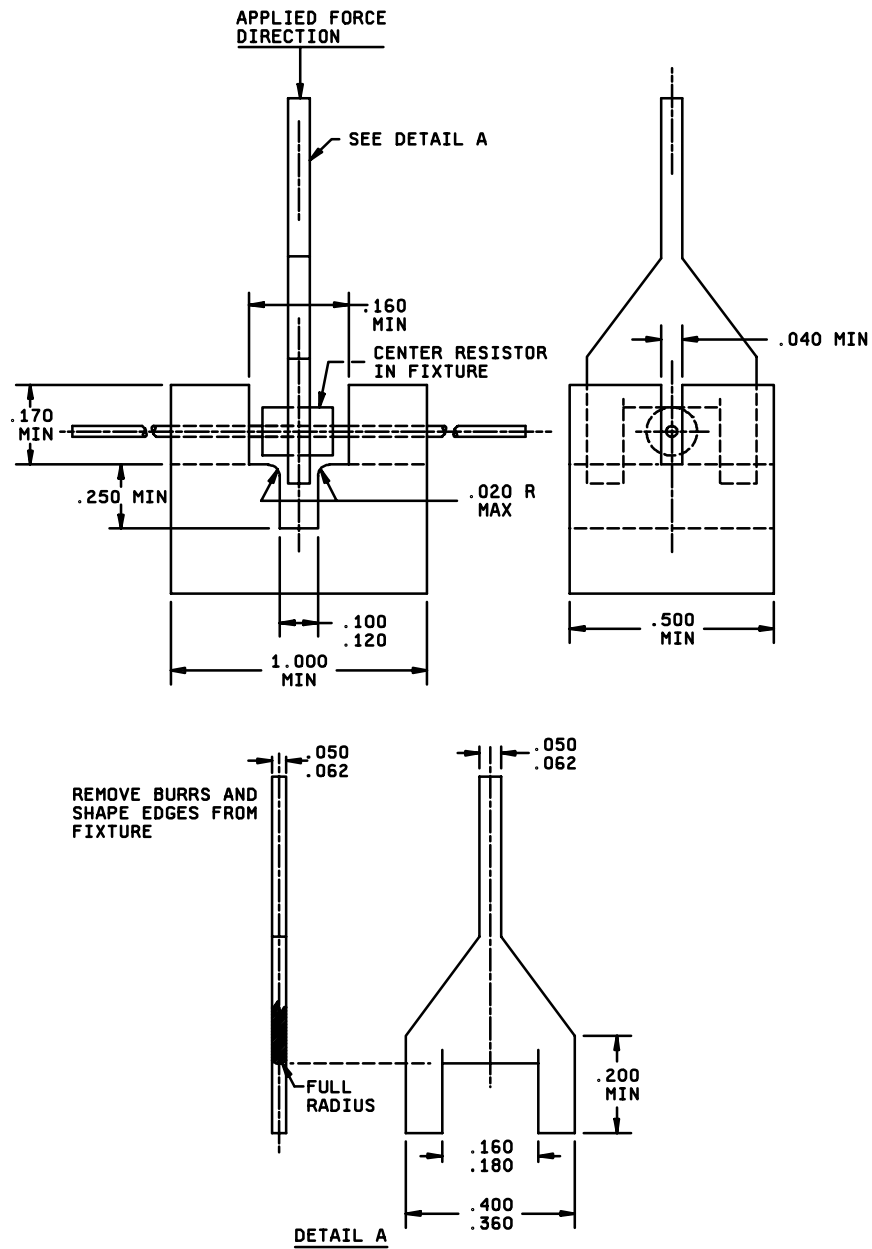

NOTES:

1. Dimensions are in inches.
2. Metric equivalents are given for general information only.

FIGURE 6. Mechanical shear.

MIL-PRF-55182G

4.8.23 Low temperature storage (see 3.29).

4.8.23.1 Mounting. Resistors shall be mounted in such a manner that there is at least 1 inch of free air space around each resistor, and in such a position with respect to the air stream that the mounting offers substantially no obstruction to the flow of air across and around the resistors.

4.8.23.2 Procedure. DC resistance shall be measured as specified in 4.8.5. Within 1 hour after this measurement, the resistors shall be placed in a cold chamber at a temperature of $-65^{\circ}\text{C} \pm 2^{\circ}\text{C}$ for a period of 24 hours ± 4 hours. The resistors shall then be removed from the chamber and maintained at a temperature $+25^{\circ}\text{C} \pm 5^{\circ}\text{C}$ for a period of 2 hours to 8 hours. The dc resistance shall again be measured as specified in 4.8.5. Resistors shall then be examined for evidence of mechanical damage.

4.8.24 Resistance noise (space level only, see 3.30). The resistance noise of resistors shall be performed using a radiometer component linearity tester type CLT1A or equivalent. A generalized schematic of the test equipment is shown on figure 7. The amount of power dissipated by the resistor shall be one half of its rated power rating or 0.25 watt, whichever is less.

The third harmonic index (THI) in dB shall be calculated as follows:

$$\text{THI (dB)} = 20 \log V_3/V_1$$

Where: V_1 = rms fundamental voltage amplitude in volts

V_3 = rms third harmonic voltage amplitude in microvolts

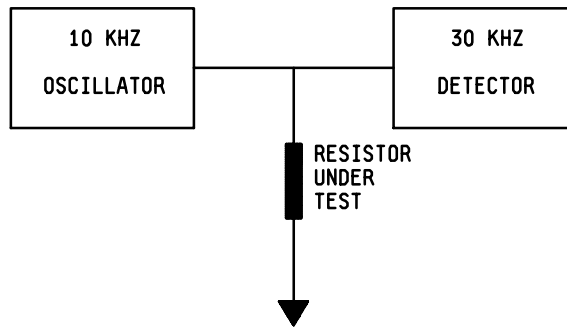

FIGURE 7. Schematic.

MIL-PRF-55182G

4.8.25 Destructive physical analysis (space level only, see 3.31). Resistors shall be examined as specified in appendix B of this document.

4.8.26 Outgassing (space level only, see 3.32). Resistors shall be tested in accordance with ASTM E-595. The following details and exceptions shall apply. Samples of any materials used shall be cut into pieces having 0.38 inch (9.6 mm) maximum dimension. A sample of 100 milligrams to 300 milligrams of material shall be weighed and then placed in a vacuum chamber under the following conditions:

Pressure - - - - - 10^{-6} torr or less.

Temperature of specimen - - Maximum operating temperature of device.

Exposure time - - - - - 24 hours.

During this exposure, a collector plate 9.7 inches (246.4 mm) in diameter shall be held at $25^{\circ}\text{C} \pm 1^{\circ}\text{C}$ near the sample. Immediately upon removal of the specimen and collector plate from the chamber, they shall be weighed. The total mass loss (TML) is sample mass before exposure minus the sample mass after exposure divided by the initial sample mass (expressed in percent change). The volatile condensable material (VCM) is the increase in the weight of the collector plate divided by the mass of sample (expressed in percent).

4.8.27 Aqueous-extract-conductivity test procedure (see 3.5.1).

4.8.27.1 Outline of method. The sample is extracted with hot water. The conductivity of electrolytic surface contaminants is measured with a conductivity bridge or resistance indicator and compared with a deionized or distilled water blank.

4.8.27.2 Apparatus.

4.8.27.2.1 Conductivity bridge. A conductivity bridge or resistance indicator which shall be capable of measuring resistance up to at least 2 megohms. Within the range of 0.3 megohm to 1 megohm inclusive, the accuracy of adjustment shall be within 5 percent.

4.8.27.2.2 Constant temperature bath. A water bath shall be maintained at $25^{\circ}\text{C} \pm 0.5^{\circ}\text{C}$. If the conductivity bridge as described in 4.8.27.2.1 is capable of automatic temperature compensation to within $\pm 0.5^{\circ}\text{C}$, the water bath temperature shall be $25^{\circ}\text{C} \pm 0.5^{\circ}\text{C}$.

4.8.27.2.3 Beakers. Two acid and alkali-resistant glass, 125 milliliter (ml), tall-form beakers or any beakers of such dimensions that when the dip-type cell is immersed in 100 ml of liquid contained therein, the electrodes are fully covered.

4.8.27.2.4 Thermometer. A thermometer having a range of -5°C to $+50^{\circ}\text{C}$ inclusive, graduated in 0.1°C intervals (for constant temperature bath). Accuracy of thermometer shall be equal to or better than one-half of the graduations.

4.8.27.2.5 Conductivity cell. Either a platinum electrode or gold electrode dip cell may be used. The dip-type cell must be securely mounted and adequately protected so that their relative positions shall not be affected by handling or moderate jarring.

Platinum cells. The area of each electrode shall be not less than 2 square centimeters (cm^2). The cell shall be so constructed that the electrodes shall be completely immersed upon dipping the cell into the liquid medium. The cell constant shall be 0.1 reciprocal cm. The electrodes shall be platinized (in accordance with 4.8.27.2.5.1) if the measurements are made at low frequency (60 cycles). At a frequency of 1,000 cycles, this precaution is unnecessary.

MIL-PRF-55182G

4.8.27.2.5.1 Preparation and calibration of platinum conductivity cell (not applicable to gold cells). If unplatinized, clean a new cell with warm chromic-acid solution, wash thoroughly with distilled water, and rinse with alcohol and ether. If the electrodes are already platinized, omit the chromic-acid wash. To platinize the electrodes, immerse the cell in a solution of 3.0 grams (g's) of chloroplatinic acid and 0.010 g of lead acetate in 100 ml of distilled water. Electrolyze, using a current density of 30 mA per cm² for 8 minutes, reversing the current every 2 minutes. Wash the electrodes thoroughly with distilled water. To test for completeness of removal of electrolyte, immerse the cell in 50 ml of distilled water and measure the resistance initially and at the end of 10 minutes; if a decrease in resistance occurs, repeat the washing. Keep the cell immersed in distilled water when not in use. To determine the cell constant, place a beaker containing 0.01 molar potassium-chloride solution in the constant temperature bath maintained at 25°C ±0.5°C. After thermal equilibrium is established, measure the resistance of this solution. The cell constant, K, may be calculated as follows:

$$K = C \times R \text{ per cm.}$$

Where: R = resistance in ohms.
 C = conductivity of the potassium-chloride solution.
 (The value for C at 25°C is 1.41×10^{-3} ohms per cm.)

4.8.27.2.5.2 Calibration of gold conductivity cell (not applicable to platinum cells). Dip the conductivity cell into a 10 µmho per cm conductivity standard solution (potassium chloride type). Adjust calibration knob on the conductivity bridge to 10 µohms.

4.8.27.3 Reagents.

4.8.27.3.1 Reagent water. Either distilled or deionized water may be used. The water must meet type II reagent water in accordance with ASTM D1193 (minimum of 1 megohm - cm).

4.8.27.3.2 Potassium-chloride solution. Prepare a 0.01 molar solution with reagent-grade potassium chloride which has been dried for 2 hours at 100°C. After cooling, dissolve 0.7455 g of the dried salt in distilled water and make up to 1 liter in a volumetric flask at 20°C.

4.8.27.4 Procedure.

- a. Place an unbroken sample or samples with a minimum surface area of 5 square inches in a suitable beaker so that a maximum of 100 ml of boiling distilled or deionized water will completely cover the sample. Prepare a blank, using a like amount of distilled or deionized water in the equivalent beaker and with both sample and blank, proceed as follows: Heat the contents of the beaker to 90°C minimum for 5 minutes ±.5 minute. Care should be taken in this operation so that the sample remains unbroken.
- b. Place the beakers in a water bath as described in 4.8.27.2.2 at 25°C.
- c. As soon as thermal equilibrium is established, place the dip-type cell in the extract solution, making certain that the electrodes are immersed to the depth specified (see 4.8.27.4a. or 4.8.27.4b). Measure the resistance on the most sensitive scale of the bridge. Move the cell up and down in the solution several times and repeat the measurement until successive readings are constant. Before each measurement, rinse the cell thoroughly in distilled or deionized water and gently shake off any water on the surface.
- d. Correct the conductivity of the extract solution for the blank using the following equation:

MIL-PRF-55182G

$$C_f = \{(C_{fs} - C_{is}) - (C_{fb} - C_{ib})\} * (5 * V) / (100 * I)$$

Where:

- C_f : conductivity of the sample tested.
- C_{fs} : final conductivity of the sample being tested.
- C_{is} : initial conductivity for the sample being tested.
- C_{fb} : final conductivity of the blank solution.
- C_{ib} : initial conductivity of the blank solution.
- V : actual volume of water used for extraction procedure (ml).
- I : actual surface area of sample tested (in²).

4.8.27.5 Report. The conductivity shall be reported in microsiemens per cm for a sample having a minimum of 5 square inches surface area.

5. PACKAGING

5.1 Packaging requirements. For acquisition purposes, the packaging requirements shall be as specified in the contract or order. When actual packaging of material is to be performed by DoD personnel, these personnel need to contact the responsible packaging activity to ascertain requisite packaging requirements. Packaging requirements are maintained by the Inventory Control Point's packaging activity within the Military Department or Defense Agency, or within the Military Department's System Command. Packaging data retrieval is available from the managing Military Department's or Defense Agency's automated packaging files, CD-ROM products, or by contacting the responsible packaging activity.

6. NOTES

(This section contains information of a general or explanatory nature that may be helpful, but is not mandatory.)

6.1 Intended use. The resistors are designed for use in critical circuitry where high stability, long life, reliable operation, and accuracy are of prime importance.

6.2 Acquisition requirements. Acquisition documents must specify the following:

- a. Title, number, date of the specification, the applicable associated specification, and the complete PIN (see 1.2.1).
- b. Issue of DoDISS to be cited in the solicitation, and if required, the specific issue of individual documents referenced (see 2.2).
- c. Packaging requirements (see 5.1).
- d. Marking requirement for FR level, temperature characteristic, and tolerance (see 3.34.4 and 3.34.5).
- e. Lead length: Specify 1.00 inch \pm .625 inch, -0.000 inch for tape and reel packaging. If not specified, 1.5 inch \pm .125 inch lead length will be supplied.

6.3 Qualification. With respect to products requiring qualification, awards will be made only for products which are, at the time of award or contract, qualified for inclusion in the qualified products list whether or not such products have actually been so listed by that date. The attention of the contractors is called to these requirements, and manufacturers are urged to arrange to have the products that they propose to offer to the Federal Government tested for qualification in order that they may be eligible to be awarded contracts or orders for the products covered by this specification. The activity responsible for the qualified products list is the US Army Communications and Electronics Command; however, information pertaining to qualification of products may be obtained from the Defense Supply Center, Columbus (DSCC-VAM), 3990 East Broad Street, Columbus, Ohio 43216-5000.

6.4 Selection and use information. Equipment designers should refer to MIL-STD-199, "Resistors, Selection and

MIL-PRF-55182G

Use of," for a selection of standard resistor types and values for any new equipment design. All applications and use information concerning these resistors are also provided in MIL-STD-199.

6.5 Terminal substitution. Hermetically sealed resistors (characteristics C and E, with terminal R) are a direct one-way substitute for nonhermetically sealed resistors (characteristics H, J, and K with terminal C), provided all other characteristics are equal or better.

6.6 Power rating at +70°C. Power ratings for resistors under this specification have been established by a 2,000 hour life test and ΔR of ± 0.50 percent. The power ratings established are as follows:

<u>Style</u>	<u>+70°C power rating</u>
RN_50	.1 watt
RN_55	.125 watt
RN_60	.25 watt
RN_65	.5 watt
RN_70	.75 watt
RN_75	2.0 watts
RN_77	2.0 watts

NOTE: Users should consider that the FR for these resistors are established at +125°C and the specified power ratings of each style (see 3.1).

6.7 Retinning (hot solder dip). If retinning (hot solder dip) of the leads is required, see 3.5.3.3.

6.8 Tin plated finishes. Tin plating is prohibited (see 3.5.3.4) since it may result in tin whisker growth. Tin whisker growth could adversely affect the operation of electronic equipment systems. For additional information on this matter, refer to ASTM B545 (Standard Specification for Electrodeposited Coating of Tin).

6.9 Key word listing. The key word listing shall be as follows:

Fixed
Film
Axial lead

6.10 Changes from previous issue. Asterisks are not used in this revision to identify changes with respect to the previous issue due to the extensiveness of the changes.

MIL-PRF-55182G

APPENDIX A

PROCEDURE FOR QUALIFICATION INSPECTION

A.1 SCOPE

A.1.1 Scope. This appendix covers the procedure for qualification inspection for resistors covered by this specification. This appendix is a mandatory part of this specification. This appendix also outlines the procedure for extending qualification to the various product levels as well as the resistance range, characteristics, tolerances, and FR levels. The information contained herein is intended for compliance.

TABLE XX. Groups from table XI.

Inspection	Number of samples	Total number of samples
<u>Group I</u> All samples (except group IA), then divide for group II through group VII, inclusive.		<u>1/</u> 316
<u>Group IA</u> 12 Any value	12 any value, group IA	
<u>Group II</u> 30 10 high value 10 critical or nearest critical 10 low value	98 critical or nearest critical	
<u>Group III</u> 30 10 high value 10 critical or nearest critical 10 low value		
<u>Group IV</u> 30 10 high value 10 critical or nearest critical 10 low value		
<u>Group V</u> 102 34 high value 34 critical or nearest critical 34 low value		
<u>Group VA</u> 102 34 high value 34 critical or nearest critical 34 low value		
<u>Group VI</u> 102 34 high value 34 critical or nearest critical 34 low value		
<u>Group VII</u> 10 10 high	98 lowest plus 10 highest	
<u>Group VIII (space level only)</u> 30 10 high value 10 critical or nearest 10 low value		

1/ Plus 102 units for group VA.

A.2 APPLICABLE DOCUMENTS. This section is not applicable to this appendix.

MIL-PRF-55182G

APPENDIX A

A.3 SUBMISSION

A.3.1 Product levels. Qualification of the C level (nonestablished reliability), is predicated upon meeting the established reliability qualification requirements for FR level P (see A.4.1). Qualification of the T level(space), is predicated upon meeting the established reliability qualifications requirements for FR level S (or FR level R for RNC90) (see A.4.1). To obtain qualification to the T level (space), the manufacturers shall also meet the additional requirements for outgassing and the 100 cycle thermal shock test (see A.3.2) as well as having been approved by the qualifying activity on the capability to conduct tests and examinations for the space level product (e.g., resistance noise, destructive physical analysis, production lot formation). The procedure for submitting samples to become qualified to the initial FR level M is specified in A.3.2.

A.3.2 Sample. A sample having any specification resistance tolerance in each style and characteristic for which qualification is sought shall be submitted and subjected to the inspection of table XI. Sample size submission and distribution shall be as follows:

- a. In addition, two unenclosed sample units of the style and characteristic for which qualification is desired shall be submitted and subjected to the visual and mechanical examination of group I of table XI.
- b. An additional sample submission is required under the following conditions:

- (1) Qualification to closer tolerance than submitted above is desired. Submit:

30 additional samples of the closer tolerance to be qualified to group I of table XI	10 high value 10 critical or nearest 10 lowest
--	--

- (2) E characteristic to be qualified by characteristic C submission. Submit:

30 additional samples of Characteristic E to group I and group II of table XI	10 high value 10 critical or nearest critical 10 lowest value
---	---

Characteristic C or characteristic E will qualify characteristic H, characteristic J, and characteristic K where the identical product is supplied for all characteristics.

- (3) J characteristic to be qualified by characteristic H submission. Submit: 30 additional samples of characteristic J to group I and group II of table XI.
- (4) Qualification to T level (space) when qualified to S FR (or R FR for RNC90). The following requirements must be met:
 - (a) Submit 30 additional samples to group VIII of table XI.
 - (b) Certification of outgassing requirement (see 3.32)
 - (c) Approval by the qualifying activity on capabilities to perform space level inspections including resistance noise, destructive physical analysis, and tighter lot formation and control.

MIL-PRF-55182G

APPENDIX A

TABLE XXI. Critical resistance values.

Style <u>1/</u>	Resistance (megohm)
RNR50	---
RNR55	0.392
RNR57	---
RNR60	0.499
RNR65	0.348
RNR70	0.237
RNR75	0.562
RNR77	0.562

1/ Third letter is variable, dependent upon lead material or capability.

A.4 EXTENT OF QUALIFICATION

A.4.1 Extension of qualification. The resistance range included in the qualification of any one resistor style will be between any two adjacent resistance values which pass the qualification inspection. Separate submissions are required for each protective coating or enclosure used except as specified in A.3.2b. Qualification of one characteristic is a basis for qualification of another characteristic, as indicated in table XXII. Also, qualification of the lower resistance tolerances will qualify the higher resistance tolerances in accordance with table XXIII. As a requisite for extension of qualification, as described herein, between characteristics, tolerance, resistance values, FR, and terminal types, the product involved must be manufactured using the same facilities, processes, and materials (excluding lead material) as the product originally submitted for qualification.

TABLE XXII. Extent of qualification of characteristics.

Characteristic submitted	Characteristic qualified
C	C, E <u>1/</u> , (H, J, K) <u>2/</u>
H	H, J <u>1/</u> , K
E	E, C, (H, J, K) <u>2/</u>
J	J, H, K
K	K

1/ See A.3.2 for added sample submission.

2/ See A.3.2b and A.4.1 for conditions of extension.

MIL-PRF-55182G

APPENDIX A

TABLE XXIII. Extension of qualification of resistance tolerances.

Resistance tolerance submitted	Resistance tolerance qualified
B D F	B, D, F D, F F

A.4.2 Extension of qualification between terminal types. The extension of qualification between terminal types will be based on certification of weldable leads type by the supplier upon qualification of a solderable lead type.

A.4.3 Extension of qualification between product levels. The extension of qualification between product levels shall be as specified in table XXIV.

TABLE XXIII. Extension of qualification of product levels.

FR LEVEL	Will qualify product level
P, R, S	C (non-er) <u>Space level</u>
S (all styles except RNC90) R (style RNC90)	T (all styles except RNC90) <u>1/</u> T (style RNC90) <u>1/</u>

1/ In addition to meeting the minimum FR levels as indicated above, the manufacturer shall also meet the additional requirements as specified in A.3.2d.

MIL-PRF-55182G

APPENDIX B

PROCEDURES FOR DESTRUCTIVE PHYSICAL ANALYSIS (SPACE LEVEL ONLY)

B.1 SCOPE

B.1.1 Scope. This appendix provides the methods and requirements for destructive physical analysis (DPA) of metal film resistors (see figure 8 and figure 9). This appendix is a mandatory part of the specification contained herein and is intended for compliance.

B.2. APPLICABLE DOCUMENTS. This section is not applicable to this appendix.

B.3 EQUIPMENT AND PROCEDURES

B.3.1 Equipment.

B.3.1.1 Sample preparation. A mechanical or chemical process shall be used to remove the outer insulating materials. This process shall cause minimal damage to the internal resistor structure.

B.3.1.2 Optical equipment. A binocular microscope with a minimum capability of 100X magnification and an integral light source or fiber optic light ring shall be used.

B.3.2 Resistor, fixed, film, styles RNC50, RNC55, RNC60, and RNC65.B.3.2.1 Method.

B.3.2.2 External visual. Examine resistors at 30X minimum magnification for cracks on epoxy coating or glass seal, flaws on the leads (nicks, cuts, crushing, or exposure of the base metal) and marking, and nonconformance with configuration requirements.

B.3.2.3 Hermeticity. Conduct seal test on each sample, when applicable, after all other tests have been performed and just prior to sample preparation for internal inspection. Seal test shall be performed in accordance with the requirements of this specification.

B.4 SAMPLE PREPARATION

B.4.1 Conformally coated resistors. Conformal coating can be mechanically or chemically removed. When mechanical means are employed, care must be taken not to induce any rejectable defect on the resistor itself. When chemically stripping the coating, use a process and material which dissolves the coating and exposes, but not attacks, the metal film, core, end terminations, leads, and welded connections, and which does not discolor or stain any surface. As required, perform Scanning Electron Microscope inspection and check for corrosion.

B.4.2 Hermetically sealed resistors.

B.4.2.1 Conformally coated, ceramic body. Strip resistor's conformal coating shall be in accordance with 40.1, then examine the hermetic packaging for any signs of contamination, cracks on the ceramic sleeve, and pits or voids on the solder seal. Open the ceramic outer packaging by using a small lathe machine to expose the metallized resistor, being careful not to introduce any contamination. Prepare the lathe by cleaning both jaws and tool bit with alcohol to remove the oils. Carefully place the resistor between the jaws so that one end protrudes. (NOTE: Do not close the jaws too tightly.) Cut the metal end cap, keeping the lead attached, just beyond the corner radius. Repeat this procedure for the other end, then slide the ceramic sleeve out to expose the internal resistor.

MIL-PRF-55182G

APPENDIX B

B.4.2.2 Glass body. Scribe the glass sleeve with a diamond wire saw, then place the resistor on a lint free tissue, and fold the tissue over. Lightly tap the device with a very small hammer, or similar device, until the glass breaks and the glass chips can be removed. Care must be exercised in performing this procedure in order not to induce damage to the internal resistor.

B.4.3 Removal of internal end caps. The end caps must be removed to inspect for any sign of corrosion, blistering, peeling away of the plating material, or metal film under the caps. This procedure shall be performed after the internal visual inspection has been completed. Roll the internal resistor between two clean flat hard surfaces. An aluminum pad and a sheet of glass has been used with success. After rolling several times, the end caps should fall off from the resistor core. Typically, the caps come off one at a time. When rolling the remaining cap, care must be taken to ensure that damage is not induced to the exposed end. Inspect caps and ends of resistor element at 30X minimum magnification. Any corrosion, peeling or blistering of the plating or metal film under the caps shall be cause for rejection.

B.5 DESTRUCTIVE PHYSICAL ANALYSIS (STYLES RNC50, RNC55, RNC60, AND RNC65)

B.5.1 Records. DPA findings that deviate from configuration and other requirements shall be documented as defects.

B.5.2 Evaluation criteria. When the DPA is conducted as a lot conformance test, the production lot shall be rejected if one or more of the DPA samples exhibit any of the defects listed below. The manufacturer has the option with qualifying activity approval to use DPA evaluation criteria tailored to the individual product. The DPA evaluation criteria shall be documented in the MIL-STD-790 program. All exposed inner surfaces of each resistor shall be examined at 30X minimum magnification for the following characteristics:

- a. Cracked or chipped core.
- b. End cap misalignment greater than 3 degrees.
- c. Weld splatter at lead-to-end cap termination, or cracks in weld joint.
- d. Cracked, split, or holes (from welding operation) on end caps.
- e. Corrosion, lifted, blistered, or missing plating material on the end caps; discoloration due to welding is not cause for rejection.
- f. Foreign material or contamination on the metal film.
- g. Any particle other than encapsulation material seated on the spiral cut.
- h. Feathering of the metal film due to laser trimming that extends to more than 50 percent of the width of the trim.
- i. Damage to resistance element, such as overtrimming, scratches, or voids, which reduces the width of any of the metallized turns to less than 50 percent of the original design value.
- j. Evidence of heavy stain or corrosion on resistance element. Discoloration of tantalum-based resistors due to thermal stabilization or laser trimming shall not be cause for rejection.
- k. Metal film lifting, peeling, or blistering as observed visually or determined by a cellophane tape test.
- l. Intermediate coating, when used, that does not extend to one-half the length of the skirt of the end caps.
- m. Discoloration, foreign material, bubbles, or pinholes on the intermediate coating, or coating that is peeling away. (Bubbles or pinholes in the pinhole material or intermediate coatings that represent less than 50 percent of the encapsulation thickness and not touching the resistive film or visible at the case outer surface

MIL-PRF-55182G

APPENDIX B

are not cause for rejection.)

n. Discolored or hollow core.

o. Excessively deep cuts due to laser trimming, i.e., laser trim cuts of more than 0.007 inch deep for thick films or 0.0005 inch deep for thin films.

p. Uncut material remaining after a laser scribe due to "skipping" of the laser beam.

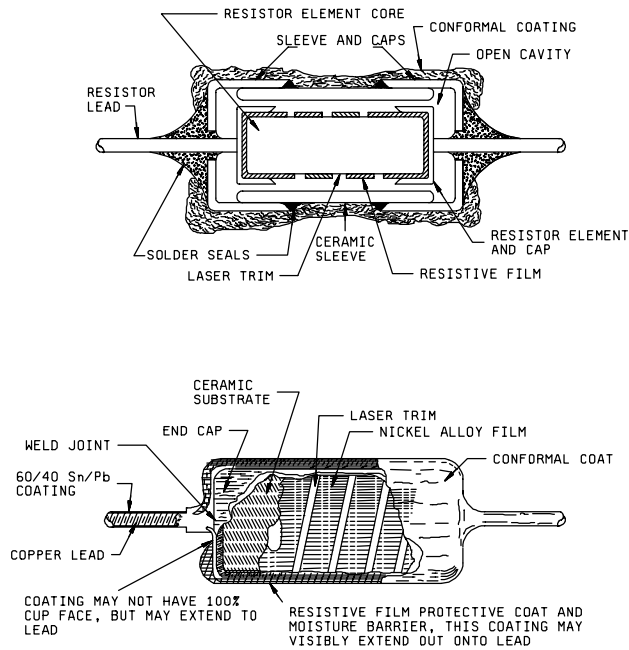
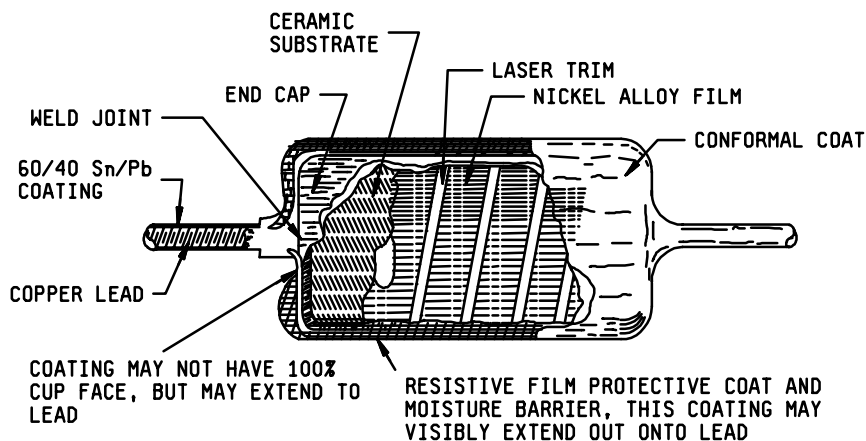

FIGURE 8. Typical hermetically sealed film resistor, RNC style.

MIL-PRF-55182G

APPENDIX B

FIGURE 9. Typical non-hermetically sealed film resistor, RNC style.

B.6 RESISTOR, FIXED, FILM, STYLE RNC90.

B.6.1 Method.

B.6.2 External visual. Conduct external visual examination as in B.3.2.2.

B.6.3 Terminal strength. A terminal strength test shall be performed on one-third of the samples in accordance with 4.8.11.

B.6.4 Sample preparation. Either of the following methods may be used in opening (exposing) resistor for internal examination:

a. Mechanical decapsulation.

- (1) Gently hold the sample at the two narrow sides parallel to the leads. Slowly grind off the flat (wide) side of the case with a 180, or finer, grit paper until the plastic is thin enough to break off with pointed tweezers or when the rubber coating starts to show through.
- (2) Repeat step 1 for the other flat side. When only the four narrow sides have the plastic case material still attached to them, gently break these off with a pair of pointed tweezers.
- (3) The rubber film surrounding the substrate package can be easily removed with the tweezers. However, the moisture barrier coating (varnish) under the rubber may not be as easy to take out. Carefully and slowly scrape the varnish with the toothpick and tweezers making sure that no rejectable defects are introduced to the resistor element.

MIL-PRF-55182G

APPENDIX B

b. Chemical decapsulation (not recommended). The case may be chemically removed using a process and material which dissolves the case and the underlying coatings and exposes, but does not attack, the resistor element, substrate, terminations, leads, and welded connections, and which does not discolor or stain any surface. The solvent used shall be identified and recorded in the report.

B.7 DESTRUCTIVE PHYSICAL ANALYSIS (STYLE RNC90)

B.7.1 Records. DPA findings that deviate from configuration and other requirements shall be documented as defects.

B.7.2 Evaluation criteria. When the DPA is conducted as a lot conformance test, the production lot shall be rejected if one or more of the DPA samples exhibit any of the defects listed below. The manufacturer has the option with qualifying activity approval to use DPA evaluation criteria tailored to the individual product. The DPA evaluation criteria shall be documented in the MIL-STD-790 program. All exposed inner surfaces of each resistor shall be examined at 30X minimum magnification for the following characteristics:

a. Cracked or chipped substrate or film. However, small chips on the edges of the substrate are permissible as long as they do not extend under the resistive pattern.

b. Substandard welding, such as:

- (1) Half of either weld footprint is missing the foil pad.
- (2) Half of either weld footprint is outside the lead tab outline.
- (3) Lead is over active grid lines.
- (4) Weld splatter.
- (5) Cracked paddle or the flat welded portion of lead terminal.
- (6) Torn ribbon connection.
- (7) Epoxy dot material running onto the active grid lines.

c. Resistor images which indicate hot spot possibility by a 75 percent reduction in grid line, or contains a bridge less than 10 percent of the line width, should be further evaluated using performance criteria as follows:

- (1) Read and record the resistance.
- (2) Apply 5 times rated power (not to exceed 300 volts) for 1 hour.
- (3) Read and record the resistance.
- (4) Reject any lot that has a resistor that exceeds 0.02 percent delta R.

d. Lifting or blistering of resistor metal.

e. Scratches or gouges in active grid area that expose or damage the film.

f. Any particle large enough to bridge active grid lines.

g. Three or more particles of any size that are detectable under 30X magnification.

MIL-PRF-55182G

APPENDIX B

Custodians:

Army - CR
Navy - EC
Air Force - 85
NASA - NA

Review activities:

Army - AR
Navy - AS, CG, MC, OS
Air Force - 17, 19, 99

Preparing activity:
Army - CR

Agent:
DLA - CC

(Project 5905-1433)

STANDARDIZATION DOCUMENT IMPROVEMENT PROPOSAL**INSTRUCTIONS**

1. The preparing activity must complete blocks 1, 2, 3, and 8. In block 1, both the document number and revision letter should be given.
 2. The submitter of this form must complete blocks 4, 5, 6, and 7.
 3. The preparing activity must provide a reply within 30 days from receipt of the form.
 NOTE: This form may not be used to request copies of documents, nor to request waivers, or clarification of requirements on current contracts. Comments submitted on this form do not constitute or imply authorization to waive any portion of the referenced document(s) or to amend contractual requirements.

I RECOMMEND A CHANGE:

1. DOCUMENT NUMBER
MIL-PRF-55182G

2. DOCUMENT DATE (YYMMDD)
9 June 1997

3. DOCUMENT TITLE RESISTORS, FIXED, FILM, NONESTABLISHED RELIABILITY, ESTABLISHED RELIABILITY, AND SPACE LEVEL, GENERAL SPECIFICATION FOR

4. NATURE OF CHANGE (Identify paragraph number and include proposed rewrite, if possible. Attach extra sheets as needed.)

5. REASON FOR RECOMMENDATION**6. SUBMITTER**

a. NAME (Last, First, Middle initial)

b. ORGANIZATION

c. ADDRESS (Include Zip Code)

d. TELEPHONE (Include Area Code)
(1) Commercial
(2) AUTOVON
(If applicable)

7. DATE SUBMITTED (YYMMDD)

8. PREPARING ACTIVITY

a. NAME
US Army Communications-Electronics Command

b. TELEPHONE (Include Area Code)
(1) Commercial (908) 427-3441
(2) AUTOVON 987-3441

c. ADDRESS (Include Zip Code)
ATTN: AMSEL-LC-LEO-E-EP
Fort Monmouth, NJ 07703-5023

IF YOU DO NOT RECEIVE A REPLY WITHIN 45 DAYS, CONTACT:
Defense Quality and Standardization Office
5203 Leesburg Pike, Suite 1403, Falls Church, VA 22041-3466
Telephone (703) 756-2340 AUTOVON 289-2340