

INCH-POUND

MIL-PRF-52308J
w/Amendment 3
03 December 2015
SUPERSEDING
MIL-PRF-52308J
w/Amendment 2
23 June 2005

PERFORMANCE SPECIFICATION

FILTER-COALESCER ELEMENT, FLUID PRESSURE

This specification is approved for use by all Departments and Agencies of the Department of Defense.

1. SCOPE

1.1 Scope. This specification covers filter-coalescer elements for use in filter-separator vessels for handling liquid petroleum fuels (see 6.1).

1.2 Classification. Filter-coalescer elements covered by this specification are of the following classes as specified (see 6.2):

Class M	-	JP8 fuel compatible (EI 1581, category M fuel (see 4.4.2))
Class M100	-	JP8+100 fuel compatible (EI 1581, category M100 fuel (see 4.4.2))

2. APPLICABLE DOCUMENTS

2.1 General. The documents listed in this section are specified in sections 3 and 4 of this specification. This section does not include documents cited in other sections of this specification or recommended for additional information or as examples. While every effort has been made to ensure the completeness of this list, document users are cautioned that they must meet all specified requirement documents cited in sections 3 and 4 of this specification, whether

Comments, suggestions, or questions on this document should be addressed to U.S. Army RDECOM, Tank Automotive Research, Development and Engineering Center, ATTN: RDTA-EN/STND/TRANS MS #268, 6501 E. 11 Mile Road, Warren, MI 48397-5000 or sent by email to usarmy.detroit.rdecom.mbx.tardec-standardization@mail.mil. Since contact information can change, you may want to verify the currency of this address information using the ASSIST Online database at <https://assist.dla.mil>.

AMSC N/A

FSC 4330

DISTRIBUTION STATEMENT A: Approved for public release; distribution is unlimited.

MIL-PRF-52308J w/Amd 3

or not they are listed.

2.2 Non-Government publications. The following documents form a part of this document to the extent specified herein. Unless otherwise specified, the issues of these documents are those cited in the solicitation or contract.

ASTM INTERNATIONAL

- | | | |
|-------------|---|---|
| ASTM D 3240 | - | Standard Test Method for Undissolved Water in Aviation Turbine Fuels (DoD adopted) |
| ASTM D 5006 | - | Standard Test Method for Measurement of Fuel System Icing Inhibitors (Ether Type) in Aviation Fuels (DoD adopted) |

(Copies of these documents are available online at <http://www.astm.org>.)

ENERGY INSTITUTE (EI)

- | | | |
|---------|---|--|
| EI 1581 | - | Specification and Qualification Procedures for Aviation Jet Fuel Filter / Separator, Fifth Edition |
|---------|---|--|

(Copies of these documents are available online at <https://www.energyinst.org/technical/technical-publications>)

2.3 Order of precedence. Unless otherwise noted herein or in the contract, in the event of a conflict between the text of this document and the references cited herein (except for related specification sheets), the text of this document takes precedence. Nothing in this document, however, supersedes applicable laws and regulations unless a specific exemption has been obtained.

3. REQUIREMENTS

3.1 First article. When specified (see 6.2), a sample shall be subjected to first article inspection in accordance with 4.2.

3.2 Materials. Material used shall be in accordance with the manufacturer's materials specifications for filter-coalescer elements, hereinafter referred to as "elements". The materials shall be capable of meeting all of the operational and environmental requirements specified herein. Materials used shall be compatible with petroleum fuels containing water, salt water, and additives as specified with no evidence of deleterious effect. Materials in contact with test waters shall be corrosion resistant. Zinc or cadmium plating, or use of brass, bronze and other copper bearing alloys shall not be permitted. Recovered materials should be used to the maximum extent practicable (see 6.7). Used, rebuilt or remanufactured components, pieces and parts shall not be incorporated in the element.

3.2.1 Material deterioration, prevention and control. The elements shall be fabricated from compatible materials, inherently corrosion resistant or treated to provide corrosion and

MIL-PRF-52308J w/Amd 3

deterioration protection for the elements expected service life in any operating and storage environment.

3.2.2 Dissimilar metals. Dissimilar metals shall not be used in intimate contact with each other unless protected against galvanic corrosion.

3.2.3 Identification of materials and finishes. The contractor shall identify the specific material, material finish or treatment for use with component and subcomponent and shall make information available upon request to the contracting officer or designated Government representative.

3.3 Interface and interoperability requirements.

3.3.1 Filter-coalescer elements. Elements shall be fabricated and assembled to the form and dimensions shown in Figure 1 to insure proper interface and interchangeability with existing filter/separator vessels.

3.3.1.1 End caps. The end caps shall be mounted perpendicular within 3 degrees to the longitudinal axis of the element.

3.3.1.2 O-ring. The O-ring packing and its retaining groove shall retain the O-ring seal during installation and operation, and the O-ring form and dimensions shall be in accordance with Figure 2 to insure proper interface and interchangeability of the elements with existing filter/separators. The O-ring shall be hydrocarbon fuels (automotive and aircraft types) resistant (see 6.9). The O-ring packing shall consist of a light coating of silicone compound or other compatible material to O-ring and O-ring grooves to facilitate installation.

3.4 Operating requirements.

3.4.1 Water coalescence. The filter element shall coalesce water into visible drops from the test fuel (see 4.4.2) at a fuel flow rate of 20 gallons per minute (gal/min or GPM) (76 liters per minute, L/min), which is hereinafter referred to as rated flow or 100% of rated flow.

3.4.2 Differential pressure and fiber migration. The differential pressure across the element, in combination with a separator stage (see 6.4.2 and 6.5), using clean, dry fuel (see 6.4.3 and as defined by EI 1581, Table 1), shall not exceed 6 pounds per square inch (psi) (42 kiloPascals (kPa)) at 100% of rated flow. The effluent fuel sample shall contain an average of not more than 10 fibers per liter and the number of fibers in any single sample shall not exceed 15 fibers per liter (see 6.4.1). The element shall incorporate sufficient radial support to withstand a differential pressure across the element of not less than 75 psi (520 kPa) without structural failure or permanent deformation.

3.4.3 Contaminant removal. The element in combination with a separator stage (see 6.5) shall remove solids and up to 3 % water by volume at fuel flow rates up to 100 % of rated flow. The effluent fuel samples shall contain not more than 15 parts per million by volume (ppmv) of

MIL-PRF-52308J w/Amd 3

undissolved water when measured in accordance with ASTM D 3240. The average weight of solids in the effluent fuel samples shall not exceed 0.26 milligrams per liter (mg/L), and the weight of solids in any single sample shall not exceed 0.5 mg/L.

3.4.3.1 Solids removal capacity. The element shall remove and retain a quantity of solids at least equal to 5.4 grams per gal/min of its rated flow capacity. The pressure differential across the element at rated flow shall not exceed 15 psi (105 kPa) before 50 minutes, nor 45 psi (315 kPa) before 75 minutes at a solids concentration in the influent test fuel of 72 mg/gal (19 mg/L).

3.5 Environmental requirements.

3.5.1 Transit drop. Each packaged element (see 5.1) shall withstand the shock of being dropped on a flat surface of solid concrete, from a height of 48 inches, by showing no evidence of cracks or deformation of the end caps or damage to element media.

3.5.2 Temperature resistance. The element shall withstand storage in fuel in temperatures ranging from -50 degrees Fahrenheit (F) to +160 °F (-46 degrees Celsius (C) to + 71 °C) after which it shall operate as specified.

3.5.3 Fuel and salt water immersion. The element, after being immersed in test fuel for 100 hours near both the high and low operating temperature limits in 3.5.2, and after immersion in salty water for 72 hours, shall show no evidence of swelling, corrosion, separation of components, dissolving of adhesives, or deformation which could cause failure during operation.

3.5.4 Post-environmental testing. The element having completed 3.5.3 shall operate as specified.

3.6 Support and ownership requirements.

3.6.1 Identification marking. Element marking shall include, as a minimum, the following information permanently marked or stamped on the element (see 6.2):

- a. NSN: (Specify)
- b. Contract or Order No.: (Specify)
- c. Lot: (Specify) (see 6.2e and 6.2f)
- d. Manufacturer's Identification: (Specify)
- e. Date of Manufacture: (Specify)
- f. Class of element: (Specify) (see 6.2b)

3.6.2 Workmanship. The element shall be free from burrs, tears, smudges, or any other defect that will impair serviceability.

MIL-PRF-52308J w/Amd 3

4. VERIFICATION

4.1 Classification of inspections. The inspection requirements specified herein are classified as follows:

- a. First Article Test inspection (see 4.2).
- b. Conformance inspection (see 4.3).

4.2 First Article Test (FAT) inspection. The contractor shall furnish a minimum of 46 elements to determine conformance to this specification (see 6.2). First Article Test (FAT) inspection shall be conducted as specified in 4.5, Table I. Presence of one or more defects or failure of any examination or test shall be cause for rejection.

4.3 Conformance inspection.

4.3.1 Lot. Unless otherwise specified (see 6.2), a lot shall consist of not more than 1000 elements, identically produced by one shift during a single day.

4.3.2 Sampling. Sampling for examinations and tests shall consist of elements randomly selected from production lots. Randomly, one out of every five production lots shall be selected for conformance testing. A total of eight elements shall be submitted from each production lot that is selected for conformance testing. All eight of the submitted samples shall be subjected to 4.5.1, Examination, three of the submitted samples shall be subjected to 4.5.2, Structural Strength, and one shall be subjected to 4.5.3, Differential Pressure/Operational Performance.

4.3.3 Inspection. Samples selected in accordance with 4.3.2 shall be examined and tested as specified in 4.5, Table I. Presence of one or more defects or failure of any test shall be cause for rejection, and for rejection of the lot represented by the sample.

4.4 Test conditions.

4.4.1 Test facility. The test facility shall be in accordance with EI 1581, section 4.2.1, Test Apparatus. Testing shall be conducted at a site selected by the Government in the contract or order (see 6.2). Both single element and full-scale tests shall be conducted using the military vessel configuration of concentric, vertical elements and separators. The single element test vessel shall be a uniform standard, single element vessel constructed by the Government. The single element test vessel shall be operated at 20 GPM (76 L/min). The full-scale test vessel shall be a military standard 350 GPM filter-separator vessel, LIN H52087. The full-scale vessel shall be operated at 350 GPM (1325 L/min). Both the single element and full-scale test vessels may be made available to the contractor upon request, for preliminary qualification testing. The facility shall contain calibrated and certified measuring equipment.

4.4.2 Test fuel and additives. The category of test fuel used shall be in accordance with the class of element (see 1.2 and 6.2), and shall be in accordance with EI 1581, section 4.2.2 Test Fuel. The additives used in the test fuel shall be in accordance with EI 1581, section 4.2.4.2

MIL-PRF-52308J w/Amd 3

Additive Package/Category M100 and M Fuels, for both class M and M100 elements. For class M100 elements, the additives shall be added to the test fuel in accordance with EI 1581, section 4.3.2.3.2 Additive Addition/Category M100 Fuel. For class M elements, the additives shall be added to the test fuel in accordance with EI 1581, section 4.3.2.3.3 Additive Addition/Category M Fuel.

4.4.3 Fuel temperature. Unless otherwise specified (see 4.5.4.2 and 4.5.4.3), the test fuel temperature shall be between +40 °F to +90 °F (+5 C to +32 °C) during testing. The test fuel temperature shall be maintained within plus or minus 11 °F (6 °C) of the starting temperature for any individual test.

4.4.4 Test contaminants. The contaminants used, and their addition to the test fuel, shall be in accordance with EI 1581, section 4.2.3 Test Contaminants.

4.4.5 Test sampling and analysis. Test sampling and measurement shall be conducted in accordance with EI 1581, section 4.7 Test Sampling, and all subsections thereof.

4.4.5.1 Icing inhibitor. The concentration of icing inhibitor in the fuel shall be determined in accordance with ASTM D 5006. Samples shall be taken for measurement prior to start of 4.5.3 (operational performance test), and immediately after the conclusion of such test.

4.5 Methods of inspection. First article and conformance inspections shall include the relevant inspections as listed in Table I.

Table I. Inspection requirements.

Inspection	First Article (23+ samples)			Conformance
	FAT, set 1 (3+samples)	FAT, set 2 (2+samples)	FAT, set 3 (18+samples)	(8 samples)
Examination, 4.5.1	X	X	X	X (all samples)
Structural strength, 4.5.2	X			X (3 samples)
Differential pressure, operational performance, 4.5.3		X		X (1 sample)
Transit drop, 4.5.4.1			X	
Resistance to fuel, high temp, 4.5.4.2			X	
Resistance to fuel, low temp, 4.5.4.3			X	
Resistance to salt water, 4.5.4.4			X	
Post-environmental performance, 4.5.4.5			X	

MIL-PRF-52308J w/Amd 3

4.5.1 Examination. The elements shall be examined for the defects specified in Table II.

Table II. Visual defects.

Defect	Paragraph
Material not as specified.	3.2
Material not resistant to corrosion and deterioration or not treated to be made resistant to corrosion and deterioration	3.2.1
Dissimilar metals in intimate contact	3.2.2
Dimensions not as shown in Figure 1	3.3.1
End caps mounting not as specified	3.3.1.1
O-Rings in ends of element missing or damaged	3.3.1.2
Dimensions of O-Rings not as shown in Figure 2	3.3.1.2
Silicone compound not present as specified	3.3.1.2 and Figure 1, note 4
Identification marking incorrect, missing or illegible	3.6.1
Workmanship not as specified	3.6.2

4.5.2 Structural strength. To determine conformance to 3.4.2, elements shall be tested in accordance with EI 1581, section 4.5.1 Structural Test. The category of test fuel used, for this test only, shall be as specified in 4.4.2, with the exception that additives are optional.

4.5.3 Differential pressure, operational performance. Test sampling schedule and procedures shall be in accordance with EI 1581, section 4.3 Single Element Test Method for Filter/Separators, and all subsections thereof for Type S filter-separators only and excludes multi-stage systems, using the single element test vessel specified. Test sampling schedule and procedures are also summarized in EI 1581, Table 4, and EI 1581, section 4.7 Test Sampling. Nonconformance to 3.4.1, 3.4.2, 3.4.3 or 3.4.3.1 shall constitute failure of this test.

4.5.4 Environmental. The environmental tests shall be conducted in the following order. The same complete set of elements shall be used for each environmental test, and the number of samples in the set shall be as stated in the contract or order (see 6.2).

4.5.4.1 Transit drop. To determine conformance to 3.5.1, each element contained in their unit package shall be dropped on a flat surface of solid concrete, from a height of 48 inches. All drops shall be made so that the element falls freely through the distance specified. The element shall be dropped eight times, four on each end of the unit package. Cracks or deformation of end caps, or damage to element media shall constitute failure of this test.

4.5.4.2 Resistance to fuel, high temperature. The elements shall be immersed in the test

MIL-PRF-52308J w/Amd 3

fuel for a minimum period of 100 hours at an ambient temperature of +140 °F (+60 °C), plus or minus 5 °F (3 °C), and examined for defects. Nonconformance to 3.5.3 shall constitute failure of this test.

4.5.4.3 Resistance to fuel, low temperature. The elements shall be immersed in the test fuel for a minimum period of 100 hours at an ambient temperature of -25 °F (-32 °C), plus or minus 5 °F (3 °C), and examined for defects. Nonconformance to 3.5.3 shall constitute failure of this test.

4.5.4.4 Resistance to salt water. The elements shall be immersed in a solution consisting of 4% sodium chloride (NaCl) and 96% distilled water by weight for a period of 72 hours, and examined for defects. Nonconformance to 3.5.3 shall constitute failure of this test.

4.5.4.5 Post-environmental performance. The elements shall be tested in accordance with EI 1581, section 4.4 Full-Scale Test Method for Filter/Coalescers, and all subsections thereof for Type S filter-separators only and excludes multi-stage systems, using the full-scale vessel specified. Test sampling schedule and procedures are also summarized in EI 1581, Table 5, and EI 1581, section 4.7 Test Sampling. Nonconformance to 3.4.2 or 3.4.3 shall constitute failure of this test.

5. PACKAGING

5.1 Packaging. For acquisition purposes, the packaging requirements shall be as specified in the contract or order (see 6.2). When actual packaging of materiel is to be performed by DoD or in-house contractor personnel, these personnel need to contact the responsible packaging activity to ascertain packaging requirements. Packaging requirements are maintained by the Inventory Control Point's packaging activities within the Military Service or Defense Agency, or within the military service's system commands. Packaging data retrieval is available from the managing Military Department's or Defense Agency's automated packaging files, CD-ROM products, or by contacting the responsible packaging activity.

6. NOTES

(This section contains information of a general or explanatory nature that may be helpful, but is not mandatory.)

6.1 Intended use. The elements are intended for use in military filter-separator vessels to remove solid contaminants and coalesce water from diesel and jet fuels. The elements covered by this performance specification are military unique since they must interface with the family of military standard filter/separators.

6.2 Acquisition data. Acquisition documents should specify the following:

- a. Title, number, and date of this specification.
- b. Class of filter-coalescer element required by the Government (see 1.2).

MIL-PRF-52308J w/Amd 3

- c. If first article inspection is required (see 3.1 and 4.2), the total number of samples, and number of elements per each FAT set (see 4.5).
- d. Identification markings including NSN, contract or order number, lot number, manufacturer's identification, date of manufacture, and fuel category compatibility (see 3.6.1).
- e. When lot size other than as specified (see 4.3.1).
- f. Test site location (see 4.4.1).
- g. Test data sheets as provided in EI 1581, Table 6 Data Sheet for Single-Element Tests, Type S Filters, and Table 7 Data Sheet for Full-Scale Tests, Type S Filters.
- h. Selection of applicable packaging and packing requirements (see 5.1).
- i. Government-loaned property. The contracting officer should arrange to loan, per the contractor's request, the equipment listed in 4.4.1, subject to availability (see 4.4.1).

6.3 Disposition of test assemblies. Elements undergoing destructive tests should be indelibly marked "DO NOT USE".

6.4 Definitions.

6.4.1 Fiber. A fiber is defined as any particle with a length-to-diameter ratio of ten to one, or more, and a length of 100 microns or more.

6.4.2 Differential pressure across the element. The differential pressure across the element is defined as the pressure drop across the filter/separator with the element installed measured from the fuel inlet coupling to the fuel outlet coupling (excluding accessory valves), less the pressure drop across the filter/separator without the element installed.

6.4.3 Clean, dry fuel. As defined by EI 1581, Table 1; also as fuel containing not more than 0.26 mg per liter of solid contamination and no free water, or an irreducible minimum amount of free water, as indicated by the test system fuel quality monitors or devices specified herein.

6.4.4 GPM. Gallons per minute, also gal/min; inch-pound flow rate.

6.4.5 L/min. Liters per minute; metric flow rate.

6.4.6 ppmv. Parts per million by volume; dimensionless, volumetric concentration.

6.4.7 mg/L. Milligrams per liter; metric concentration.

6.4.8 psi. Pounds per square inch; inch-pound pressure.

6.4.9 kPa. Kilopascals; metric pressure.

6.5 Separator stages. Satisfactory performance of filter/separators utilizing the elements cited in 3.4.1, has been based on the use of water-removing separators that physically strip the

MIL-PRF-52308J w/Amd 3

coalesced water droplets from the flowing fuel stream. The vertical filter/separators used by the military utilize a cylindrical canister (separator) that surrounds each element and contains a 100-mesh monel (or stainless steel) screen coated with polytetrafluoroethylene, a hydrophobic material. Drawings 13216E2773 and 13217E6316 are mentioned for reference guidance only.

6.6 Subject term (key word) listing.

Contamination Filtration
Separator
Fuel

6.7 Recovered materials. For the purpose of this requirement, recovered materials are those materials which have been collected from solid waste and reprocessed to become a source of raw materials, as distinguished from virgin raw materials. The components, pieces and parts incorporated in the element may be newly fabricated from recovered materials to the maximum extent practicable, provided the element produced meets all other requirements of this specification.

6.8 Solid contaminants. The solid contaminants can be obtained from the following suppliers.

- a. Red iron oxide, obtainable from Harcros Pigments Inc., 2001 Lynch Avenue, East St. Louis, IL 62205, identified as Copperas Red Iron Oxide no. R9998.

(Contact this supplier online at <http://www.harcros.com>)

- b. A1 Ultrafine Test Dust ISO 12103-1, obtainable from Powder Technology Inc., 1300 Grey Fox Road, Arden Hills, MN 55112.

(Contact this supplier online at <http://www.powdertechinc.com>)

6.9 Hydrocarbon fuel resistant O-rings. Historically, the hydrocarbon fuel resistant O-rings were manufactured in accordance with MS29513-123.

6.10 Part Identification Number (PIN). The following part identification numbering procedure is for Government purposes and does not constitute a requirement for the contractor. This example describes a part numbering system for MIL-PRF-52308J:

MIL-PRF-52308J w/Amd 3

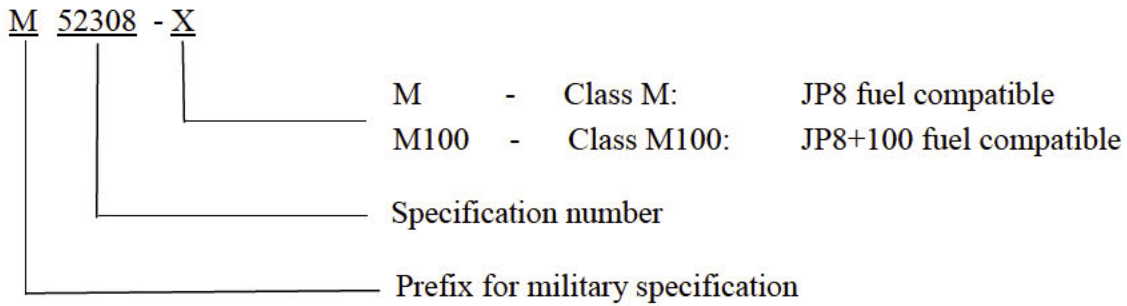

6.11 Amendment notations. The margins of this specification are marked with vertical lines to indicate modifications generated by this amendment. This was done as a convenience only and the Government assumes no liability whatsoever for any inaccuracies in these notations. Bidders and contractors are cautioned to evaluate the requirements of this document based on the entire content irrespective of the marginal notations.

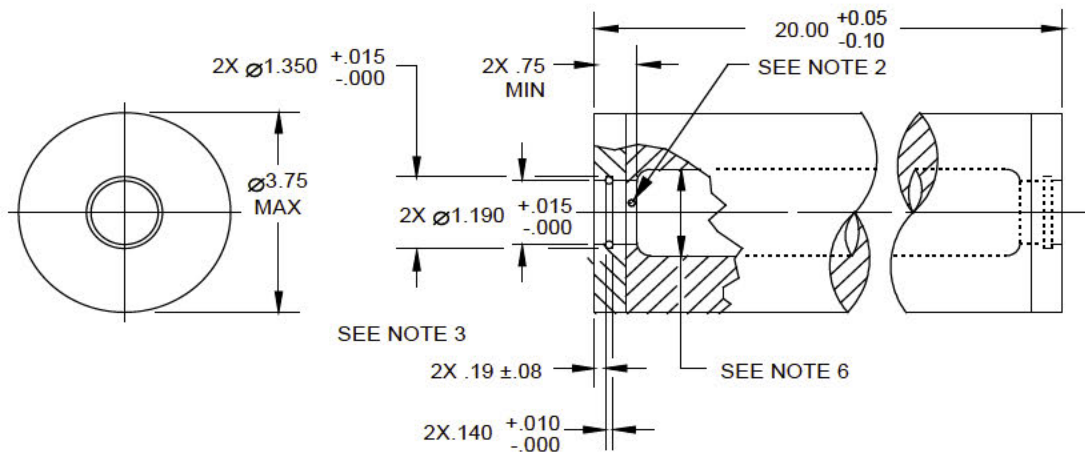

NOTES:

1. DIMENSIONS ARE INCHES.
2. THIS AREA TO BE LEFT FREE FROM FILTER ELEMENT MATERIAL, BOTH ENDS.
3. PROVIDE O-RING IN EACH END GROOVE.
4. APPLY LIGHT COATING OF SILICONE COMPOUND TO O-RING GROOVES AND O-RING.
5. FLOW SHALL BE FROM INSIDE TO OUTSIDE.
6. INSIDE DIAMETER AND CONFIGURATION ARE OPTIONAL.
7. REFERENCE: FOR USE WITH 1.182-1.187 MALE GLAND AT 100 PSI MIN, BOTH ENDS.
8. NOMINAL RATE OF FLOW IS 20 GPM.

FIGURE 1. Filter-coalescer element.

MIL-PRF-52308J w/Amd 3

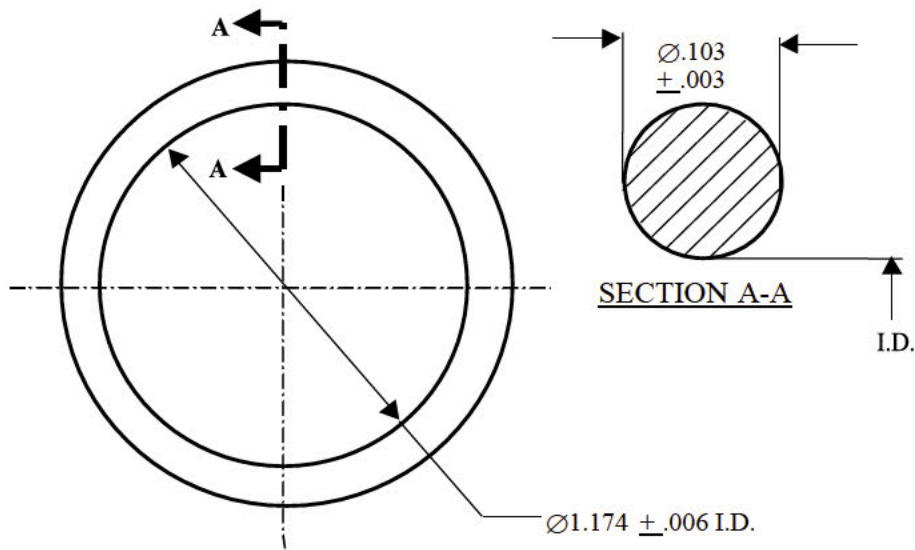

FIGURE 2. O-ring size and geometry.

Custodians:

Army – AT
Navy – AS
Air Force – 11

Preparing Activity:

Army – AT

(Project 4330-2015-002)

Review Activities:

Army – AV, MI
Navy – MC
Air Force – 68, 99
DLA – CC

NOTE: The activities listed above were interested in this document as of the date of this document. Since organizations and responsibilities can change, you should verify the currency of the information above using the ASSIST Online database at <https://assist.dla.mil>.