

INCH-POUND

MIL-PRF-51200C(EA)

8 September 1999

SUPERSEDING

MIL-S-51200B(EA)

1 August 1994

PERFORMANCE SPECIFICATION

SAMPLING KIT, CBR AGENT M34A1

Reactivated for new design after 8 September 1999

This specification is approved for use by the U.S. Army Edgewood Chemical Biological Center, Department of the Army, and is available for use by all Departments and Agencies of the Department of Defense.

1. SCOPE

1.1 Scope. This specification covers one type of sampling kit for the collection of soil, surface, and liquid samples which may contain chemical agent contaminants.

2. APPLICABLE DOCUMENTS

2.1 General. The documents listed in this section are specified in sections 3 and 4 of this specification. This section does not include documents cited in other sections of this specification or recommended for additional information or as examples. While every effort has been made to insure the completeness of this list, document users are cautioned that they must meet all specified requirements documents cited in sections 3 and 4 of this specification, whether or not they are listed.

Beneficial comments (recommendations, additions, deletions) and any pertinent data which may be of use in improving this document should be addressed to: Technical Director, U.S. Army Edgewood Chemical Biological Center, ATTN: AMSSB-REN-SS, Aberdeen Proving Ground, MD 21010-5424 by using the self-addressed Standardization Document Improvement Proposal (DD Form 1426) appearing at the end of this document or by letter.

AMSC N/A

FSC 6665

DISTRIBUTION STATEMENT A. Approved for public release; distribution is unlimited.

MIL-PRF-51200C(EA)

2.2 Government documents.

2.2.1 Specifications, standards, and handbooks. The following specifications, standards, and handbooks form a part of this document to the extent specified herein. Unless otherwise specified, the issues of these documents are those listed in the issue of the Department of Defense Index of Specifications and Standards (DODISS) and supplement thereto, cited in the solicitation (see 6.2).

STANDARDS

DEPARTMENT OF DEFENSE

MIL-STD-810 – Environmental Test Methods and Engineering Guidelines

2.3 Order of precedence. In the event of a conflict between the text of this document and the references cited herein, the text of this document takes precedence. Nothing in this document, however, supersedes applicable laws and regulations unless a specific exemption has been obtained.

3. REQUIREMENTS.

3.1 First Article. When specified (see 6.2), a sample shall be subjected to first article inspection in accordance with 4.2.

3.2 Materials and components. The contractor shall select the materials and components needed to meet the requirements contained herein. The sampling kit shall consist of a carrier case containing the compartments and components summarized in Table I. Components of the sampling kit shall conform to the requirements in 3.3. See also component information in 6.5.

MIL-PRF-51200C(EA)

TABLE I. Components of kit

No.	Compartment	Components	Function	Qty
1	Soil sampling compartment	Overgloves	To prevent chemical cross contamination of samples between sampling points	4
		Scoops	To collect soil samples	3
		Bags, small	To hold soil sample containers	3
		Bag, large	To hold bagged sample containers	1
		Sample containers	To contain soil samples	3
		Custody seals	To insure sample integrity and provide sample identification information	6
		Forms	To list sample information & chain of custody	1
		Radioactive label	To warn of radioactive material	1
2	Pocket	M8 Paper, Chemical Agent Detector	To detect and identify liquid chemical agents	1
		Tape, labeling	To seal large bags and document sample identification information	1
		Marker	To write on forms, custody seals and labeling tape	1
		Snips or heavy duty scissors	To open component packaging as needed and collect samples of contaminated vegetation and other solid materials	1
		Drawstring bags	To store smaller bags with samples, secure collected samples to operator or equipment, and function as a drop cloth during sample collection as needed	3
3	Surface/Material sampling compartment	Wipes	To absorb liquid samples from surfaces	3
		Tweezers or forceps	To hold sample wipes and materials, and transfer samples to sample containers	3
		Bags, small	To hold sample containers	3
		Bag, large	To hold bagged sample containers	1
		Sample containers	To contain surface sample wipes and other samples of materials	3
		Custody seals	To insure sample integrity and provide sample identification information	6
		Forms	To list sample information & chain of custody	1
4	Liquid sampling compartment	Syringes	To collect liquid samples	2
		Extension tubes	To extend reach of syringes	2
		Bags, small	To hold liquid sample containers	2
		Bag, large	To hold bagged sample containers	1
		Sample containers	To contain liquid samples	2
		Forms	To list sample information & chain of custody	1
		Custody seals	To insure sample integrity and provide sample identification information	4

MIL-PRF-51200C(EA)

3.3 Functional and physical requirements of components.**3.3.1 Overgloves.**

3.3.1.1 Chemical resistance. During sample collection, the overgloves shall provide a barrier to prevent cross contamination of the inner Mission Oriented Protective Posture (MOPP) IV gloves by liquid or solid contaminants. The gloves shall be made of a material which resists deterioration by organic solvents to an extent equal or greater than nitrile rubber.

3.3.1.2 Fit and coverage. Overgloves shall be flock-lined and capable of fitting over MOPP IV gloves, size large (NSN 8415-01-138-2499), and shall be at least 12 inches in length.

3.3.1.3 Slip resistance. Overgloves shall have embossed gripping surfaces to resist slip.

3.3.1.4 Color. Overgloves shall be black in color or of a color that contributes to field camouflage (e.g. dark green, brown or tan).

3.3.2 Scoops.

3.3.2.1 Capacity. Each scoop shall be capable of collecting a soil sample and transferring the collected sample to a sample container without spillage. The minimum container capacity of the scoop shall be 65 milliliters. The size and shape of the scoop shall enable the end of the barrel part of the scoop to fit inside the mouth of a sample container to prevent spillage.

3.3.2.2 Strength. The handle of the scoop shall not break or deform by more than 3/4 inch when experiencing a 3 pound load. The barrel of the scoop shall not break.

3.3.3 Sample containers.

3.3.3.1 Capacity. Each sample container shall consist of a seal forming container with a capacity capable of holding a minimum of 3 ounces of water by volume. The container opening shall be at least 1.75 inches in diameter minimum.

3.3.3.2 Transparency. The sample container shall be clear or translucent to permit the ready determination that a sample is present in the container without opening the sample container.

3.3.3.3 Leak, permeation and chemical resistance. The sample container shall not allow droplets or vapors of agent Mustard (HD) or Sarin (GB) to permeate through any of the container materials or to escape from the enclosed container for at least 48 hours. (See 4.3.6.4.)

3.3.3.4 Snug fitting parts. If the container consists of a jar, cap, and gasket(s), the gasket(s) shall not fall out of the cap during operation. Any caps shall be removable and replaceable by hand without tools.

MIL–PRF–51200C(EA)

3.3.3.5 Shatter resistance. The sample containers shall show no evidence of breakage following 4 foot drop testing described in 4.3.6.15.

3.3.4 Custody seals.

3.3.4.1 Easy peel off. The seal shall be capable of being peeled off its initial backing when the user is wearing MOPP IV gloves and overgloves.

3.3.4.2 Adhesion to materials. Each custody seal shall consist of an adhesive–backed, pressure–sensitive labeling material capable of adhering to the small bag in 3.3.6.1 and sample container in 3.3.3 (see note 6.4). When the custody seal is applied to the small bag in 3.3.6.1, it shall not be removable by hand without breaking (destroying) part of the seal itself.

3.3.4.3 Physical attributes. The custody seal shall be long enough to go over the container’s cap and sides and adhere to both surfaces. The center–most portion of the custody seal shall adhere to the container’s cap and each end portion shall adhere to the container’s sides. The width shall be at least one inch to allow space for legible hand–written identification information using the kit’s marker. The custody seal shall include the following pre–printed words as a minimum for sample identification: “Name”, “Sample No.”, “Date” and “Time” separated by underlined blank spaces. The seal may also contain the pre–printed word “Location”.

3.3.4.4 Color. The color shall be white or another light color with sufficient contrast with the kit’s marker to ensure legibility.

3.3.5 M8 Paper. The booklet of M8 Paper, Chemical Agent Detector, NSN 6665–00–050–8529 shall be Government furnished.

3.3.6 Bags.**3.3.6.1 Small bags.**

a. Size. Each small bag for primary back–up containment of the sample containers shall measure no larger than 7 inches by 11 inches.

b. Strength. Each bag shall be capable of passing the load capacity tests described in 4.3.6.6. The primary containment bag shall not puncture or tear when a 1.0 pound load is placed inside the bag.

c. Leak resistance. Without any external materials other than a single layer of labeling tape, each bag shall be capable of being sealed by personnel in MOPP IV. Each bag shall prevent water leakage when tested for leakage in accordance with 4.3.6.7.

3.3.6.2 Large bags.

a. Size. Each large bag for secondary back–up containment of up to three bagged sample

MIL–PRF–51200C(EA)

containers shall measure no larger than 12 inches by 12 inches and shall be colored to protect samples from light, distinguish bag from others, and to contribute to field camouflage.

b. Strength. Each bag shall be capable of passing the load capacity tests described in 4.3.6.6. The secondary containment bag shall not puncture or tear when a 3.0 pound load is placed inside the bag.

c. Leak resistance. Without any external materials other than a single layer of labeling tape, each bag shall be capable of being sealed by personnel in MOPP IV. Each bag shall prevent water leakage when tested for leakage in accordance with 4.3.6.7.

3.3.6.3 Drawstring bags.

a. Operability. Each drawstring bag shall be a tertiary bag that is capable of storing at least 8 sample containers surrounded by primary and secondary bags.

b. Size. Each drawstring bag shall be at least 18 inches long and 182 inches wide, and shall have a pull type draw–string closure incorporated in the bag opening. The draw–string closure shall provide a secure means of closing the bag which precludes unintentional opening of the bag. Each drawstring bag shall have at least one drawstring. Each drawstring shall be at least 24 inches in length or circumference.

c. Strength. Each drawstring bag shall have a minimum load capacity of 15 pounds without puncture or tear of the bag or breakage of the drawstring when tested in accordance with 4.3.6.8.

d. Resistance to water. Each bag shall not absorb more than 5 grams of water when tested in accordance with 4.3.6.10.2.

3.3.7 Labeling tape.

3.3.7.1 Adhesion to materials. The labeling tape shall be a waterproof, self–adhesive, pressure–sensitive tape capable of being removed from the roll and securely adhering to the kit’s bags and jars in temperatures ranging from -20°F to 120°F . An operator wearing MOPP IV gloves and overgloves shall be capable of tearing off or cutting off sections of labeling tape. The tape’s top surface shall be capable of being permanently marked by the kit’s marker in temperatures ranging from -20°F to 120°F .

3.3.7.2 Size. Its width shall be 1.5 ± 0.25 inch and length of the roll shall be 200 to 500 inches. The tape shall be of a size that fits inside a pocket or compartment of the carrier.

3.3.7.3 Color. The tape’s color shall be white, or another light color with sufficient contrast with the kit’s marking ink to ensure legibility.

3.3.8 Marker.

MIL–PRF–51200C(EA)

3.3.8.1 Physical attributes. The marker shall consist of a non–refillable pen, with re–sealable cap, containing an indelible black ink.

3.3.8.2 Legible writing. The type of marker and width of the marking shall enable an operator who wears Mission Oriented Protective Posture (MOPP) IV gloves and overgloves to produce a clearly legible writing on the custody seal and labeling tape when testing in accordance with 4.3.6.16. The marker shall produce a bold writing on the custody seal and labeling tape in temperatures ranging from -20°F to 120°F after low and high temperature conditioning storage according to 4.3.6.13 and 4.3.6.14. Marking shall not smear when touched by a wet finger after being allowed to dry for not greater than 20 seconds.

3.3.8.3 Easily held. The marker shall be of a size that is easily held without dropping by an operator who wears MOPP IV gloves and overgloves.

3.3.9 Snips.

3.3.9.1 Ability to cut packaging. The snips shall be capable of cutting packaging materials when used properly by any operator who wears MOPP IV gloves and overgloves without injury or damage to the gloves.

3.3.9.2 Ability to cut twigs. The snips shall be capable of cutting samples of vegetation including twigs up to 1/4” thick in diameter when tested in accordance with 4.3.6.9.

3.3.9.3 Physical attributes. The snips shall have blunt tips with dull finish blades.

3.3.10 Wipes.

3.3.10.1 Absorption capacity. Each wipe shall consist of a lint–free cloth wipe capable of absorbing a minimum of 10 milliliters (0.33 ounce) of water in a single operation.

3.3.10.2 Size. The wipe shall be at least 4 inch by 4 inch in size and shall easily fit into one of the kit’s sample containers.

3.3.10.3 Absence of dyes. The wipes shall not contain any materials, dyes or additives that could adversely affect the analysis process for chemical warfare agents.

3.3.11 Tweezers (forceps).

3.3.11.1 Ability to hold wipes and materials. An operator wearing MOPP IV gloves and overgloves shall be capable of securely grasping and holding surface sampling wipes and material samples up to 1/2 inch thick. Tips of tweezers shall not pierce wipes or gloves during normal use.

3.3.11.2 Capable of locking closed. The tweezers shall remain in the closed position when no finger pressure is applied and shall open when finger pressure is applied.

MIL–PRF–51200C(EA)

3.3.12 Syringe and extension tube.

3.3.12.1 Capacity of syringe. The syringe shall consist of a disposable, barrel and plunger type tool, with a 50 milliliter capacity, used to transfer liquid samples to the sample jars.

3.3.12.2 Extension tube length. The extension tube shall consist of semi–flexible heavy duty tubing not less than 9 inches in length.

3.3.12.3 Connect/disconnect ability. The extension tube shall easily connect to and disconnect from the syringe without the use of tools, and shall enable the syringe to collect liquid samples from hard to reach locations.

3.3.12.4 Non interfering side reactions. The syringe (including barrel, plunger rod and plunger tip) and the extension tube shall be made from a non–reacting or slow–reacting material which will not interfere with the ability to analyze the sample for chemical warfare agents. Tip of plunger shall not be made of rubber.

3.3.12.5 Shock resistance. The syringe and extension tube shall show no evidence of breakage following 4 foot drop testing described in 4.3.6.15.

3.3.12.6 Movement. The plunger shall move freely in and out with normal hand force.

3.3.13 Carrier case.

3.3.13.1 Containment. The carrier case shall consist of 4 compartments (or 3 compartments and one pocket) plus a detachable carrier strap. Each compartment for soil, liquid and surface samples shall have a closure mechanism to prevent spillage and reduce water intrusion. The carrier case compartments shall be capable of fully containing all sampling kit components identified in Table I.

3.3.13.2 Size. The external dimensions of the filled carrier case shall not exceed a volume of 1320 cubic inches with no dimension to exceed 12 inches.

3.3.13.3 Color. The carrier case shall be olive green in color or as otherwise specified in the contract (see 6.2).

3.3.13.4 Strap adjustable and detachable. The strap attached to the carrier case shall be capable of being adjusted from a minimum of 29 inches to a maximum of 47 inches (including any fasteners) by any wearer to allow a snug fit. The strap shall be capable of being detached from the carrier case and re–attached while the operator wears MOPP IV gear.

3.3.13.5 Resistance to water. The carrier case, with compartment fasteners in the closed position and oriented upright, shall not absorb more than 90 grams of water when subjected to the water repellency test in accordance with 4.3.6.10.1.

MIL–PRF–51200C(EA)

3.3.13.6 Resistance to fungus and mildew. Carrier case shall resist moderate and severe fungus/mildew growth.

3.3.13.7 Strength. After water resistance test, the wetted carrier case shall be capable of withstanding an overload condition of 5.0 pounds in every compartment and pocket without causing stretching, breaking or tearing of the material in any of the compartments, between any compartments, and around connecting straps or fasteners.

3.3.13.8 Physical attributes. The carrier case, when filled with all components, shall have no sharp or protruding features which could damage MOPP IV gear.

3.3.13.9 Noise. The carrier case, when filled with all components, shall not produce a detectable rattling sound from a distance of 25 feet.

3.3.14 Forms. The soil, surface and liquid sample compartments shall each contain one government furnished, chemical/biological agent sample documentation form for recording background information.

3.3.15 Instruction cards. Instruction cards shall be printed on 3 x 5 inch ($\pm 1/2$) waterproof cards. The printing on the cards shall be black on light background. The minimum font size shall be 10. The cards shall be joined by metal ring(s) to permit viewing. Printing may be on both sides in sequential order so that the cards will not have to be reoriented by the operator in order to read. The operator shall not be able to tear cards with fingers. The information to be printed on the cards shall be as follows:

M34A1 Sampling Kit Instructions

Soil Sampling Procedures:

1. Locate and prepare your sampling target area and sample documentation.
2. Don the overgloves provided.
3. Open bags containing the scoop and sampling containers.
4. Scoop a thin layer of top soil (not more than 0.5 inch deep) from a small area into the sample container. Fill the sample bottle to 3/4 of its volume.
5. Screw the cap on tightly. Place the sample bottle in a sealable plastic bag provided. Write identification information on custody seal and apply custody seal over a rolled end section of the plastic bag.
6. Place the sample bag in an larger plastic bag and seal after all soil samples are in the bag.
7. Discard the gloves, scoop and other equipment.

Surface Sampling Procedures

1. Locate and prepare your sampling target area and sample documentation.

MIL–PRF–51200C(EA)

2. Don gloves and open a packet of containers containing wipes.
3. Open container and grasp wipe with self–locking tweezers. Softly scrub the targeted surface. Place the wipe back in the container. Discard tweezers.
4. Screw the cap on tightly. Place the sample container in a sealable plastic bag provided. Write identification information on custody seal and apply custody seal over a rolled end section of the plastic bag.
5. Place the sample bag in an larger plastic bag and seal after all surface samples are in the bag.

Liquid Sampling Procedures

1. Fill in the documentation and custody form.
2. Don gloves and open bag of jars and a bag containing the extension tube and syringe.
3. Place the extension tube on the end of the syringe.
4. To collect sample, gently pull the handle of the syringe until the syringe is full of liquid.
5. Empty the water from the syringe into a container. Repeat procedure until container is filled to 75% of its volume.
6. Screw the cap on tightly. Secure the sample container in a sealable plastic bag provided. Write identification information on custody seal and apply custody seal over a rolled end section of the plastic bag.
7. Place the sample bag in a larger plastic bag and seal after all liquid samples are in the bag.

3.3.16 Radioactive warning label. Each radioactive warning label shall be adhesive–backed and water–proof. The area of the label shall be a maximum of no greater than 12 square inches. An operator wearing MOPP IV gloves and overgloves shall be capable of removing the label from its adhesive backing.

3.3.17 Cleaning of internal components. Any packaged components internal to the kit shall be cleaned or free of contaminants prior to packaging.

3.3.18 Instructions for use. Detailed instructions shall be prepared as part of the kit and used as a training aide. The example detailed instructions in Appendix A are based on the parts list in Table V. The detailed instructions in Appendix A may be altered to reflect the actual components selected for the kit. Illustrations may be used to support any of the steps in the instructions. A parts list shall be included in the instructions. Instructions shall be prepared in a booklet form. The dimensions of the booklet shall be 5.75 ± 0.125 inches wide by 4.50 ± 0.125 inches high. The pages and cover shall be securely fastened (e.g stapled) together. The front and back covers shall have a paper basis weight of at least 50 (at least 135 grams per square meter). The pages shall be printed on white paper. Font size for the text shall be 10 or larger.

3.3.19 Grouping and packaging of internal components. Clear plastic tubing, 4 mil minimum thickness, sealed at each end, shall be used to group similar parts and protect them. The strength of the seal shall be a level such that a secure fit is observed with a minimum of excess air at time of packaging. Components shall be packaged in the following groups:

MIL–PRF–51200C(EA)

- (a) Containers (e.g. jars) and custody seals in each compartment where such items are stored
- (b) Containers with one wipe in each container and custody seals for storage in compartment for surface sampling.
- (c) Labeling tape (individually packaged)
- (d) Scoops (individually packaged)
- (e) Overgloves, 1 pair (individually packaged)
- (f) Syringe and extension tube
- (g) Tweezers (forceps) (individually packaged)

The entire kit and Instructions for Use (see 3.3.18) shall be sealed within a waterproof barrier overwrap. The overwrap is considered part of the kit. For external packaging, see 6.2(d).

3.4 User performance requirements.

3.4.1 Weight. Weight of carrier case with entire contents shall not exceed 5.1 pounds when sampling containers are empty.

3.4.2 MOPP IV compatibility. The sampling kit carrier and all components shall be capable of being easily and fully functioned, in accordance with the requirements contained in this specification, by an operator wearing MOPP IV gear. Each compartment of the carrier shall be easily and quickly opened and closed with normal hand force. Components shall be easily removed from and replaced into each compartment.

3.4.3 Ease of sample collection. The time between opening of the kit for sample collection and the time a double-bagged sample container is placed in drawstring bag shall be no longer than 10 minutes when operated by personnel wearing MOPP IV gear in accordance with 4.3.6.16.

3.5 Environmental performance requirements. Environmental stress is integrated into the following requirements.

3.5.1 Low temperature storage. None of the components of the kit and associated packaging shall show any signs of visual damage, degradation or deformation after storage for 1 week at -60°F (-51°C). The sampling kit shall meet the custody seal requirements of 3.3.4.2, labeling tape requirements of 3.3.7.1, marking requirements of 3.3.8.2, and syringe requirement of 3.3.12.6 after low temperature storage and conditioning in accordance with 4.3.6.13.

3.5.2 High temperature storage. None of the components of the kit and associated packaging shall show any signs of visual damage, degradation or deformation after storage for 2 weeks at 160°F (71°C). The sampling kit shall meet the custody seal requirements of 3.3.4.2, labeling

MIL–PRF–51200C(EA)

tape requirements of 3.3.7.1, marking requirements of 3.3.8.2, and syringe requirement of 3.3.12.6 after high temperature storage and conditioning in accordance with 4.3.6.14.

3.5.3 Shock/shatter resistance.

3.5.3.1 Low temperature. After 4 hours of temperature conditioning at 14°F (–10°C) followed by a 4 ft drop, the entire sampling kit shall show no indications of damage to components in Table I (e.g. punctures, tears, breakage).

3.5.3.2 High temperature. After 4 hours of temperature conditioning at 120°F (49°C) followed by a 4 ft drop, the entire sampling kit shall show no indications of damage to the components in Table I (e.g. punctures, tears, breakage).

3.6 Support and Ownership requirements.

3.6.1 Identification and marking. The marking on each carrier of each filled kit shall include the name of the item, manufacturer, date of manufacture, model and/or serial number. Some of this information may be in the form of a lot number. Marking shall be clear and legible and shall resist fading and smearing. The marking shall be visible from the outside of the closed carrying case. Additional information such as contract number may be required by solicitation (see 6.2). Lot number system shall be will be used in accordance with 4.3.1. Verification shall be in accordance with 4.3.5. Compartments will be labeled soil, water, and surface as appropriate.

3.6.2 Workmanship. The sampling kit shall be free of workmanship defects such as sharp edges which pose a safety hazard, breakage, tears, cracks, and foreign matter. Verification shall be in accordance with 4.3.5.

3.6.3 Shelf life of assembled kit. The kit should be designed for a shelf life of at least ten years.

MIL-PRF-51200C(EA)

4. VERIFICATION

4.1 Classification of inspections. The inspection requirements specified herein are classified as follows:

- (a) First article inspection (see 4.2)
- (b) Quality conformance inspection (see 4.3)

4.2 First article inspections.

4.2.1 Sample. The first article samples shall consist of 15 kits manufactured using the same methods, materials, equipment, and processes as will be used during regular production unless otherwise specified in solicitation (see 6.2(f)). The 15 kits shall be divided into 3 sample groups of 5 sample kits as in Table II. Group I samples are for abbreviated operational testing without chemical agents. Group II are for technical tests. Group III are for potentially destructive tests that involve chemical agents. See 6.7.

MIL-PRF-51200C(EA)

TABLE II. First Article Tests

	Item	Requirement	Requirement paragraph	Verification Method
I	Overgloves	Chemical resistance	3.3.1.1	COC
I		Fit and coverage	3.3.1.2	4.3.6.16
I		Slip resistance	3.3.1.3	4.3.6.16
II	Scoops	Capacity	3.3.2.1	4.3.6.1
II		Strength	3.3.2.2	4.3.6.5
II	Sample containers	Capacity	3.3.3.1	4.3.6.2
II		Transparency	3.3.3.2	VI
III		Leak, permeation and chemical resistance	3.3.3.3	4.3.6.4
II		Snug fitting parts	3.3.3.4	VI
II		Shatter resistance	3.3.3.5	4.3.6.15
I	Custody seals	Easy peel off of backing	3.3.4.1	4.3.6.16
I, II		Adhesion	3.3.4.2	4.3.6.13, 4.3.6.14
I		Physical attributes	3.3.4.3	4.3.6.16
II		Color	3.3.4.4	VI
II	M8 paper	Present and correct	3.3.5	VI
II	Bags, sml	Size	3.3.6.1a	CE, VI
II		Strength	3.3.6.1b	4.3.6.6
II		Leakage	3.3.6.1c	4.3.6.7
II	Bags, lrg	Size	3.3.6.2a	CE, VI
II		Strength	3.3.6.2b	4.3.6.6
II		Leakage	3.3.6.2c	4.3.6.7
I	Bags, drawstring	Operability	3.3.6.3a	4.3.6.16
II		Size	3.3.6.3b	CE, VI
II		Strength	3.3.6.3c	4.3.6.8
II		Resistance to water	3.3.6.3d	4.3.6.10.2

NOTES: CE – Commercial inspection equipment; VI – Visual inspection;
COC – Certificate of Compliance with supporting evidence

MIL-PRF-51200C(EA)

TABLE II (Continued). First Article Tests

	Item	Requirement	Requirement paragraph	Verification Method
II	Labeling	Adhesion to materials	3.3.7.1	4.3.6.13, 4.3.6.14
II	tape	Size	3.3.7.2	CE
II		Color	3.3.7.3	VI
II	Marker	Physical attributes	3.3.8.1	VI
II		Legible writing on labels	3.3.8.2	4.3.6.13, 4.3.6.14
I		Easily held	3.3.8.3	4.3.6.16
I	Snips	Ability to cut packaging	3.3.9.1	4.3.6.16
II		Ability to cut twigs	3.3.9.2	4.3.6.9
I		Physical attributes	3.3.9.3	VI
II	Wipes	Absorption capacity	3.3.10.1	4.3.6.3
II		Size	3.3.10.2	CE
II		Absence of dyes	3.3.10.3	COC
I	Tweezers	Hold wipes & materials	3.3.11.1	4.3.6.16
I		Capable of locking closed	3.3.11.2	4.3.6.16
II	Syringe & ext. tube	Capacity, syringe	3.3.12.1	4.3.6.2
II		Length, extension tube	3.3.12.2	CE
I		Connect/disconnect ability	3.3.12.3	4.3.6.16
II		Non-interfering side reactions	3.3.12.4	COC
II		Shock resistance	3.3.12.5	4.3.6.15
II		Movement	3.3.12.6	4.3.6.13, 4.3.6.14
II	Carrier	Containment	3.3.13.1	4.3.6.16
II		Size	3.3.13.2	CE
II		Color	3.3.13.3	VI
I		Strap adjustable and detachable	3.3.13.4	4.3.6.16
II		Resistance to water	3.3.13.5	4.3.6.10.1
—		Resistance to fungus & mildew	3.3.13.6	4.3.6.11
II		Strength	3.3.13.7	4.3.6.12
II		Physical attributes	3.3.13.8	VI
II		Noise	3.3.13.9	4.3.6.17
II	Forms	Present	3.3.14	VI

MIL–PRF–51200C(EA)

TABLE II (Continued). First Article Tests

	Item	Requirement	Requirement paragraph	Verification Method
II	Instruction cards	Present and correct	3.3.15	VI
II	Radiation warning label	Present and correct	3.3.16	VI
II	Cleaning	Components free of contaminants	3.3.17	COC
II	Instructions for use	Physical attributes	3.3.18	CE
II	Grouping	Similar items co-located/packaged	3.3.19	VI
II	Entire kit	Weight	3.4.1	CE
I		MOPP IV compatibility	3.4.2	4.3.6.16
I		Ease of sample collection	3.4.3	4.3.6.16
II	Entire kit	Environmental performance		
II		Low temperature storage	3.5.1	4.3.6.13
II		High temperature storage	3.5.2	4.3.6.14
II		Shock/shatter resistance	3.5.3	4.3.6.15
II	Entire kit	Ownership and support		
II		Identification and markings	3.6.1	VI
II		Workmanship	3.6.2	VI
		Shelf life	3.6.3	4.3.6.18

4.2.2 Inspections to be performed. As determined by the Government, the sample first article items may be subjected to any or all of the examinations and tests herein. Samples shall be examined and tested in accordance with Table II. Verification of requirements shall be attained by visual inspection, commercial inspection equipment, testing in accordance with this specification, or by Certificate of Compliance (COC) as indicated in Table II. The Government reserves the right to approve or disapprove COCs and each COC must cite some type of technical basis such as the vendor's own product specifications, handbooks, historical test data, information from trade association, or experience with similar chemicals.

4.2.3 Acceptance criteria. If any first article sample item fails to comply with any of the applicable requirements, the first article sample shall be rejected.

MIL–PRF–51200C(EA)

4.3 Conformance inspection.

4.3.1 Lotting. A lot shall consist of sampling kits produced and assembled by one manufacturer, at one plant, from the same materials, with the same process, and without a break in production of more than 10 calendar days. Each lot shall be identified by an alphanumeric lot number. The lot number shall include a manufacturer's identification symbol, a numeric code identifying the year of production, a code or abbreviation that signifies the month of production, and an interfix–serial number. The interfix–serial number will change if there is a change in the design, process, materials, suppliers, production run, or if a new contract is issued. For the sampling kit, a lot will normally be considered the entire production quantity under a single contract unless there is a change in design, process, or materials which could adversely affect a critical or major characteristic. If there is a change in design, process, or materials for one of the components of the kit, quality conformance inspection need not be repeated on those components which have not undergone a change in design, process, or materials.

4.3.2 Sampling. Sampling of lots shall be in accordance with classification of characteristics in 4.3.5. Samples shall be selected at random.

4.3.3 Inspection procedure. Sample items shall be examined and tested in accordance with the classification of characteristics in 4.3.5, Table IV. Failure of any sample item to conform to any critical or major characteristic in 4.3.5 shall be cause for rejection of the lot represented. Failure of any sample item to conform to any minor characteristic in 4.3.5 may be cause for rejection of the lot represented.

4.3.4 Inspection characteristics. Critical characteristics are characteristics whose nonconformance to specified requirements is likely to result in hazardous or unsafe conditions for individuals using, maintaining, or depending upon the product or whose nonconformance to specified requirements is likely to prevent performance of the tactical function of a major end item. Major characteristics are characteristics whose nonconformance to specified requirements is likely to result in failure or to reduce materially the usability of the item for its intended purpose. Minor characteristics are characteristics whose nonconformance to specified requirements is not likely to reduce materially the operation or usability of the item for its intended purpose.

4.3.5 Classification of characteristics. Conformance examinations and tests shall be as specified in the following classification of characteristics paragraphs (see Table IV). When specified herein, accept on 0 and reject on 1 attributes sampling inspection shall be performed on the designated characteristics using the stated levels in Table III for selection of sample sizes.

MIL-PRF-51200C(EA)

TABLE III. Sampling

Lot size	Inspection level and samples sizes										
	I	II	III	IV	V	VI	VII	VIII	IX	X	XI
2 to 8	*	*	*	*	*	*	*	*	5	3	2
9 to 15	*	*	*	*	*	*	13	8	5	3	2
16 to 25	*	*	*	*	*	20	13	8	5	3	3
26 to 50	*	*	*	*	32	20	13	8	5	5	5
51 to 90	*	*	*	50	32	20	13	8	7	6	5
91 to 150	*	*	125	50	32	20	13	12	11	7	6
151 to 280	*	*	125	50	32	20	20	19	13	10	7
281 to 500	*	315	125	50	48	47	29	21	16	11	9
501 to 1200	*	315	125	75	73	47	34	27	19	15	11
1201 to 3200	1250	315	125	116	73	53	42	35	23	18	13
3201 to 10000	1250	315	192	116	86	68	50	38	29	22	15
10001 to 35000	1250	315	294	135	108	77	60	46	35	29	15
35001 to 150000	1250	490	294	170	123	06	74	56	40	29	15
150001 to 500000	1250	715	345	200	156	119	90	64	40	29	15
500001 and over	1250	715	435	244	189	143	102	64	40	29	15

*Indicates one hundred percent inspection. If sample size exceeds lot size, perform one hundred percent inspection. Accept the lot represented on zero nonconforming characteristics and reject the lot represented on one or more nonconforming characteristics for all inspection levels.

MIL-PRF-51200C(EA)

TABLE IV. Classification of Characteristics

PARAGRAPH	TITLE	SHEET 1 OF 1	DRWG NO.	
4.3.5	Sampling Kit, M34A1			
CATEGORY	CHARACTERISTIC	SAMPLING	REQUIREMENT PARAGRAPH	INSPECTION METHOD
Critical	None			
Major				
101	Components present and placed in the intended compartment	Table III, level VIII	3.2	VI
102	Components conform to requirements in 3.3	Table III, level VIII. See note 6.7	3.3	VI, CE, COC
Minor				
201	Color	Table III, level VIII	3.3	VI
202	Identification and marking, correct and legible	Table III, level VIII	3.6.1	VI
203	Workmanship	Table III, level VIII	3.6.2	VI
<u>NOTES:</u>				
CE – Commercial inspection equipment VI – Visual inspection COC – Certificate of Compliance				

4.3.6 Tests. For all tests, the tolerance of temperature shall be $\pm 2^{\circ}\text{F}$ unless otherwise stated.

4.3.6.1 Volumetric capacity, scoop. Obtain a soil sample by collecting or scooping a 1/2 inch thick layer of soil from the earth. Transfer soil without any soil spillage from the scoop into a sample container of known volume (see 4.3.6.2) or into a volumetric cylinder having an opening equivalent in size to the sample container.

4.3.6.2 Volumetric capacity, containers and syringes. Determine volumetric capacities by filling sample containers and syringes with water to full capacity and discharging water into a volumetric cylinder. Check for compliance with 3.3.3.1 and 3.3.12.1

4.3.6.3. Absorption capacity of wipes. Test shall be conducted at ambient temperature 70°F (21°C). Obtain tare weights on each sample wipe. Cover a flat solid surface with 50 ml of water

MIL-PRF-51200C(EA)

and allow it to free flow for each sample wipe tested. Lightly rub the wetted surface with the wipe until it is fully wet. Reweigh each wetted sample wipe. Determine the amount of water absorbed by the weight difference and compare against the requirement.

4.3.6.4 Leakage, permeation, and chemical resistance, containers.

4.3.6.4.1 Test set-up. The test set-up shall be configured to detect leakage and/or permeation of chemical agent through or around any component of the sample container. An example set-up is shown in figure 1. Each of 16 sample containers shall be enclosed in a larger secondary container within an environmental chamber with temperature control. More than one primary container – secondary container combination may be connected to the selection stream system. A source of forced air is necessary to provide at least 1 liter per minute of airflow through the secondary container. A Miniature Continuous Air Monitoring System (MINICAMS) or other chemical agent monitor capable of detecting 3 nanograms of HD vapor during a 3-minute sampling time will be installed downstream of the secondary container to detect chemical agent which escapes from the primary container.

Figure 1. Leak detection system for sample containers.

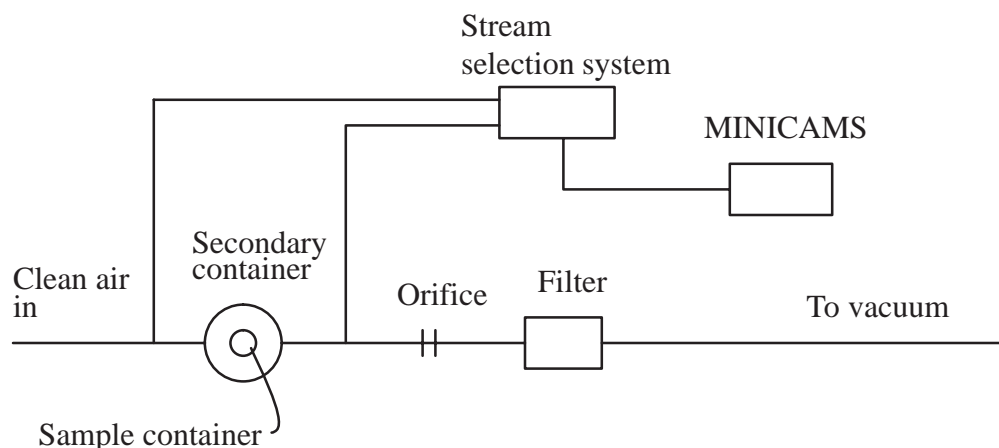

4.3.6.4.2 Procedure, neat agent Mustard. Prepare 8 unused sample containers as follows. (Each kit has 8 sample containers.) Don MOPP gloves prior to adding chemical agent. Place a 10 mg (10 microliters) drop of neat Mustard (HD) agent inside each container or its cap. The placement of the drop should vary between sample containers. The drop should be placed at random locations inside the container and its cap, including the surface of each container's gasket (if it has one). Seal each container by attaching cap with optional gasket. Use firm but normal hand torque when attaching cap or cap assembly. Place each sample container into a secondary container in an upright position. Verify that the sample containers and secondary containers are placed within an environmental chamber. While forced air is flowing at 1.0 (+0.2, -0.0) liter per minute

MIL-PRF-51200C(EA)

through the secondary container and the MINICAMS “on”, apply the following operating mode temperature profile to the air in the environmental chamber:

1. Temperature at time zero is 77°F (25°C).
2. Raise the temperature to 120°F (49°C) over a 2 hour period.
3. Hold temperature at 120 °F (49°C) for 6 hours.
4. Lower the temperature from 120°F to 14°F (-10°C) over a 4 hour period.
5. Hold temperature at 14°F (-10°C) for 6 hours.
6. Raise the temperature from 14°F (-10°C) to 77°F (25°C) over a 2 hour period.
7. Hold at 77°F (25°C) for 4 hours.
8. Repeat steps 2 through 7 once more to complete the 48-hour mission.

During the 48 hour storage mission, each container will be sampled at least once every hour by the MINICAMS. During a sampling period, the MINICAMS will draw air at 1.0 (-0.2, +0.0) liter per minute from the secondary container for 3 minutes. After each sample containing agent is sampled, purge the MINICAMS with fresh air by sampling fresh air for 3 minutes. If the MINICAMS detects any leakage or permeation from any sample, the sample container fails. Remove any defective samples.

4.3.6.4.3 Procedure, neat agent Sarin (GB). Prepare 8 unused sample containers for testing. Follow the same procedures as in 4.3.6.4.2 except substitute GB for HD.

4.3.6.5 Scoop strength. Place the handle of the scoop horizontally in a vise or fixture such that the fixture grips a 2 inch long section in the middle area of the handle. Apply a force of 3 pounds within 1 inch of the end of the scoop’s barrel in a downward direction perpendicular to the scoop’s handle. Inspect the barrel end of scoop for evidence of deformation in excess of 3/4 inch from the centerline of the handle. Inspect the entire scoop for evidence of cracks or breakage. Next, place the handle of the scoop vertically in a vise or fixture such that the handle is below the barrel and the vise grips a 2 inch long section in the middle of the handle. Apply a force of 3 pounds vertically downward on the scoop’s barrel in a direction that is parallel to the scoop’s handle. Again, inspect the entire scoop for evidence of deformation in excess of 3/4 inch, cracks or breakage.

4.3.6.6 Load capacity, bags.

4.3.6.6.1 Small bags. Place a sample bag on a smooth horizontal surface in the open position. Stacking of the test load shall be avoided if possible. Add a weight of 0.9 ± 0.1 pound to the inside of the sample container and apply cap. Place the loaded container in a small bag. Grasp the bag within 2 inches of the top and raise the bag until the bottom of the bag is at least 12 inches from the floor. Hold the bag in this position for 60 seconds. Repeat this process for two additional bags. Any bag tear or spillage of the test load constitutes a failure.

4.3.6.6.2 Large bag. Place 3 small bags loaded as in 4.3.6.6.1 into one large bag. Grasp the bag within 2 inches of the top and raise the bag until the bottom of the bag is at least 12 inches from

MIL-PRF-51200C(EA)

the floor. Hold the bag in this position for 60 seconds. Any bag tear or spillage of the test load constitutes a failure.

4.3.6.7 Leakage, bags.

4.3.6.7.1 Small and large bags. Place the sample bag in a clean container with smooth sides prior to adding water. For a small, primary containment, sample bag, pour 3 ounces of water at 70°F (21°C) into the bag and seal the closure by hand. Both the small and large bags may be sealed by removing excess air, rolling the open end of the bag, and applying a single layer of labeling tape of the kit. For a large, secondary containment, sample bag, pour 9 ounces of water at 70°F into the bag and seal the closure by hand. Grasp each sample bag within 2 inches of the top and raise the bag until the bottom of the bag is at least 12 inches from the floor. Hold the bag in this position for 60 seconds. Inspect for leaking water. Next, grasp each sample bag within 2 inches of the bag's bottom and raise until the closure of the bag is at least 12 inches from the floor. Hold each sample bag in this up-side-down position for 60 seconds and inspect closure area of bag for leakage. Any leaking water dripping from bag constitutes a failure.

4.3.6.7.2 Drawstring bags. Pour 24 ounces of water at $70 \pm 2^\circ\text{F}$ into the bag while the bag is in the upright position. Grasp the drawstring and raise the bag until the bottom of the bag is at least 12 inches from the floor. Hold the bag in this position for 60 seconds. Inspect for leaking water.

4.3.6.8 Strength, drawstring bag. Place each sample drawstring bag on a smooth horizontal surface in the open position. The test load shall be free from burrs and sharp edges. Add a 15 pound test load to each sample drawstring bag. Stacking of the test load shall be avoided if possible. Grasp the drawstring(s) by hand and raise the bag such that the bottom of the bag is at least 12 inches above the floor. Hold the bag in this position for 60 seconds and observe drawstring(s) and bag for any breaks or tears.

4.3.6.9 Cutting ability, snips. After donning MOPP IV gloves and overgloves, demonstrate that packaging materials used to protect kit components may be cut with the snips. Also, demonstrate that 1/4" diameter birch dowel rod may be severed with the snips. (This is intended to simulate the cutting of twigs from trees).

4.3.6.10 Resistance to water

4.3.6.10.1 Carrier. After removing the plastic wrap or bag from the carrier, weigh the carrier bag. Maintain a water bath for carrier immersion at $64 \pm 18^\circ\text{F}$. Prior to immersion, verify fasteners are in their closed positions. Immerse the empty carrier with the highest point 1 to 2 inches below the surface of a water bath for one minute. Remove the bag from the water bath and then pour out any water held up in the compartments or pockets while shaking bag by hand for 10 seconds. Drip-dry the bag at $75 \pm 5^\circ\text{F}$ by suspending carrier in an up-side-down position for 10 minutes and then re-weigh the bag. Determine the weight gain due to water absorption. Immediately after this test, perform strength test in accordance with 4.3.6.12.

MIL-PRF-51200C(EA)

4.3.6.10.2 Drawing string bag. Weigh the bag. Immerse the bag with the highest point 1 to 2 inches below the surface of a water bath for one minute. The temperature of the water shall be $64 \pm 18^\circ\text{F}$. Remove the bag from the water bath and pour out any water held up in the bag while shaking the bag by hand for 10 seconds. Drip-dry the bag at $75 \pm 5^\circ\text{F}$ by suspending bag in an up-side-down position for 10 minutes, then re-weigh the bag. Determine the weight gain due to water absorption.

4.3.6.11 Resistance to fungus and mildew, carrier. The requirement is met if supporting evidence is submitted that demonstrates that carrier material is the same nylon material type used in NSN 6545-00-912-9870. If selected carrier material differs from that of NSN 6545-00-912-9870, perform a fungus test on each sample carrier case in accordance with method 508.4 of MIL-STD-810. The incubation period (during which the carrier case is exposed to fungus) shall be 28 days at a temperature of 75 to 88°F (24 to 31°C) and relative humidity above 90 percent. At the end of the incubation period, gently wash, rinse and dry sample carrier cases. Then inspect carrier case for evidence of microbial growth and estimate the grade of microbial growth in accordance with Table 508.4-1 of MIL-STD-810. Grades 1 (no growth), 2 (slight growth) and 3 (moderate growth) are allowed before rinsing carriers. Grades 1 and 2 are allowed after rinsing; grades 3 and 4 are not allowed after rinsing.

4.3.6.12 Strength, carrier. The purpose of this test is to determine the strength of the material between adjacent compartments, the material within each compartment, and the material which attaches to any fastener component (e.g. D-ring, zipper, etc.). This test is to be performed immediately after 4.3.6.10.1. Add a 5.0 pound weight to each of the compartments and pocket(s) of the carrier case and close each compartment and pocket if possible. Suspend the loaded carrier case one foot off the ground with the carrier case strap draped over a cylindrical object having a diameter of 2 to 3 inches. Add a 5.0 pound weight to each of the compartments and pocket(s) of the carrier case. After 5 minutes of downward pull by 20 pounds of load, inspect carrier case including all areas between compartments and areas around connectors for signs of stretching, tears and breaks.

4.3.6.13 Low temperature storage, entire kit. Two (2) overwrapped sample kits shall be stored for 1 week at -60°F (-51°C). After the kits are removed from the temperature chamber, inspect all components of the kit including any associated packaging for signs of damage, degradation and deformation. Condition the kit for 4 hours at -20°F (-29°C). Determine whether custody seals, labeling tape, marker, and syringe comply with 3.3.4.2, 3.3.7.1, 3.3.8.2, and 3.3.12.6, respectively at -20°F (-29°C). Then perform shock test in 4.3.6.15.

4.3.6.14 High temperature storage, entire kit. Two (2) overwrapped sample kits (which have not undergone low temperature storage in 4.3.6.13) shall be stored for 2 weeks at 160°F (71°C). After the kits are removed from the temperature chamber, inspect all components of the kit including any associated packaging for signs of damage, degradation and deformation. Check for any peeling of custody seals from their backing. Condition the kit for 4 hours at 120°F (49°C). Determine whether custody seals, labeling tape, marker, and syringe comply with 3.3.4.2, 3.3.7.1, 3.3.8.2, and 3.3.12.6, respectively at 120°F (49°C). Then perform shock test in 4.3.6.15.

MIL–PRF–51200C(EA)

4.3.6.15 Shock resistance, entire kit. Immediately following 4.3.6.13 and 4.3.6.14, a total of four (4) overwrapped sample kits shall be dropped onto a 1/2–inch thick plywood sheet resting on concrete. Items from low temperature storage shall be dropped after being temperature conditioned at -20°F for 4 hours per 4.3.6.13. Items from high temperature storage shall be dropped after being temperature conditioned at 120°F for 4 hours per 4.3.6.14. Drop each sample kit three times in a random orientation from a height of 4.0 (+0.2, –0) feet. Remove all components of the kit and examine for punctures, cracks and breakage. No puncturing, cracking or breaking shall be allowed for the carrier case and any component of the kit including all plastic overwrap. As a second test, remove one jar or container from each sample kit. Fill containers to 75% by volume with water and seal. Drop filled sample containers, one from each sample kit, three times in a random orientation from a height of 4.0 (+0.2, –0) feet. Examine sample containers including caps for cracks, breakage, leakage. As a third test, remove syringes from each sample kit and drop one sample syringe from each sample kit three times in a random orientation from a height of 4.0 (+0.2, –0) feet. Cracks, breakage, deformation or leakage constitute a failure.

4.3.6.16 Operational test. An abbreviated operational test shall be conducted after a test participant (operator) has received training in the use of the item. Practice exercises are allowed before the timed functional configuration check. While the operator is wearing MOPP IV gear including the Battledress Overgarment and gloves, the operator shall don the kit. An acceptable operating temperature is any temperature between -20°F and 120°F . After one or more practice trials following the Instructions for Use (Appendix A), demonstrate that the sample collection process requires no more than 10 minutes (see 3.4.3) for each primary mission type (soil sample, surface sample and liquid sample). Also, determine whether requirement paragraphs summarized in Table II which cross reference this operational test are met.

4.3.6.17 Noise. At an outdoor site with minimal background noise, shake a carrier case filled with the entire kit components. A second person, 25 feet from the person shaking the kit, should be unable to hear any rattling sound from the kit. The item fails if the second person hears a rattling sound from the kit.

4.3.6.18 Shelf life. Historical information including anti–corrosion properties, fungal growth indications, experience with packaging materials on similar materials shall be assessed to determine whether it is likely that a 15 or higher year shelf life will be achieved for the most vulnerable items in the kit.

5. PACKAGING

5.1 Packaging. For acquisition purposes, packaging requirements external to the kit shall be as specified in the contract or order (see 6.2). When actual packaging of materiel is to be performed by DOD personnel, these personnel need to contact the responsible packaging activity to ascertain requisite packaging requirements. Packaging requirements are maintained by the Inventory Control Point’s packaging activity within the Military Department or Defense Agency, or within the Military Department’s System Command. Packaging data retrieval is available from the managing

MIL–PRF–51200C(EA)

Military Department's or Defense Agency's automated packaging files, CD–ROM products, or by contacting the responsible packaging activity.

6. NOTES

(This section contains information of a general or explanatory nature that may be helpful, but is not mandatory.)

6.1 Intended use. The sampling kit covered by this specification is intended primarily for use in collecting soil, surface, and liquid environmental samples in an area that is suspected of being contaminated with chemical warfare agents. The kit enables the soldier to apply the tactics of collecting samples as presented in FM 3–18, Special NBC Reconnaissance and FM 3–19, NBC Reconnaissance. The sampling kit is military unique because the chemical agent leakage and permeation requirements for containers at temperature extremes are more strict than those of industry, and, while many of the components represent commercial items, the entire kit is not expected to be used by the commercial sector.

6.2 Acquisition requirements.

- (a) Title, number, and date of this specification.
- (b) Issue of DODISS to be cited in the solicitation, and if required, the specific issue of individual documents referenced
- (c) First article:
 - (1) Time allowed for contractor submission of samples for Government test and evaluation after award of contract when testing is performed by the Government.
 - (2) Name and address of test facility and shipping instructions when testing is performed by the Government.
 - (3) Time required for the Government to notify the contractor whether or not to proceed with production.
- (d) External packaging requirements.
- (e) Additional identification or marking requirements, if required, must be in the contract and cite the identification method and responsibility for the items affected, such as test units, components, serial numbers, Julian date, lot numbers, etc.
- (f) Color of carrier case (see 3.3.13.3)
- (g) Government furnished property (see 3.3.14)

6.4 Container design. An all Teflon® jar with a seal area, thread number, size and dimensions corresponding to that of part number 0103 manufactured from Savillex Corp in year 1997 and a cleanly cut Viton® insert placed snugly inside the Teflon–lined cap of the jar passed the requirement in 3.3.3.3 for agent Mustard and Sarin during one Government test. The custody seal prototypes passed the adhesion requirements in 3.3.4.2 when they were applied to the small polyethylene bag but failed the requirement when they were applied to an all Teflon® jar.

MIL–PRF–51200C(EA)

6.5 Source of materials and components. The parts listed in Table V were used by the Government in a prototype sampling kit. The Government, however, does not guarantee that use of these components will result in a sampling kit that will pass all requirements of this specification.

TABLE V. Parts list

Item	Vendor/Manufacturer	Components	Part No.
Soil sampling compartment	Lab Safety Supply	Nitrile gloves, 16 mils	TL–26075
	Whatman LabSales	Scoops	6614F4122
	All–Pak, Inc.	Bags, 7”x11”	PLD–011568
	Whatman LabSales	Bags, 12”x12”	6614A1359
	Saville Corporation	Teflon Jars*, round 3 oz	0103
	Daniels Scientific Inc.	Custody seals	NPC 8002
Miscellaneous pocket or compartment	Whatman LabSales	Tape, labeling	6600A1064
	Whatman LabSales	Marker, lab	6600A1107
	Lab Safety Supply	Scissors/Snips	TL–14328
	Associated Bag Co.	Drawstring bags	59–5–06
Surface sampling compartment	The Texwipe Company	Swipes, 4.5” x 4.5”	TX304
	Techni–Tool	Self Locking Tweezers	758TW402
	All–Pak, Inc.	Bags, 7”x11”	PLD–011568
	Whatman LabSales	Bags, 12”x12”	6614A1359
	Saville Corporation	Jars*, round 3 oz	0103
	Daniels Scientific Inc.	Custody seals	NPC 8002
Liquid sampling compartment	Whatman Lab Sales	Syringes, 20 cc	6603F2014
	Berghof/America	Extension tube	1507–250156
	All–Pak, Inc.	Bags, 7”x11”	PLD–011568
	Whatman LabSales	Bags, 12”x12”	6614A1359
	Saville Corporation	Jars*, round 3 oz	0103
	Daniels Scientific Inc.	Custody seals	NPC 8002
Carrying case, all compartments			NSN 6545–00–912–9870

*The Teflon jar configuration consisted a Teflon jar, Teflon cap and a 2” diameter, 1/16” thick commercial grade Viton liner inserted in each cap to provide a seal. The Viton material used was Ameraflex part no. 1444–006–48.

6.6 Government furnished equipment/material.

- (a) Nine chemical/biological agent sample documentation forms
- (b) Three MOPP IV gloves
- (c) Three Battledress Overgarments
- (d) Paper, Chemical Agent Detector, VGH, ABC–M8 (as required)

MIL-PRF-51200C(EA)

6.7 Submission of alternative inspection provisions. Proposed alternative inspection methods and plans may be submitted by the contractor to the procuring contracting officer for evaluation by the Government.

6.8 Subject term (key word) listing.

- (a) Soil sample
- (b) Liquid sample
- (c) Surface sample
- (d) Chemical warfare agents
- (e) Detection

6.9 Changes from previous issues. Marginal notations are not used in this revision to identify changes with respect to the previous issue due to the extensiveness of the changes.

6.10 Safety. All applicable safety rules, regulations, and procedures must be followed. This specification requires testing with Chemical Surety Material (CSM) which is potentially hazardous to personnel. Testing with CSM will be conducted in a facility approved by the U.S. Army. All procedures which include handling, using, and storing CSM must be in compliance with the contract clause "Safety Provisions for Contracts Involving Chemical Surety Material and Other Related Military Unique Chemical Compounds".

Custodian:

Army - EA

Preparing activity:

Army - EA

(Project No. 6665-A717)

MIL–PRF–51200C(EA)

APPENDIX A

INSTRUCTIONS FOR USE,
SAMPLING KIT, CBR AGENT M34A1

A.1 SCOPE. This appendix describes the normal operating procedures which an operator must follow to obtain a soil, surface or liquid sample when using the M34A1 sampling and collection kit.

A.2 PROCEDURE**A.2.1 General instructions.** Important reminders:

- Verify that the kit contains at least one functioning marking pen prior to a sampling mission.
- Kit contains only four (4) pairs of overgloves. Plan their usage to avoid cross-contamination between sampling points.
- Use M8 paper to confirm the presence of suspected liquid chemical agent.
- After each sample collection, discard all used gloves and other components that might cause cross contamination. Items should be left at the point where samples are collected.
- The upwind sample will be used by the laboratory as a control sample to characterize the background conditions of the sample site.
- Use extreme caution when operating scissors in a contaminated environment so no cuts or nicks are made in the MOPP gloves.
- Take care not to cross thread the caps on the jars. Leakage of jar contents will occur when the cap is cross threaded.
- Write as much information as possible on sample documentation forms and custody seals prior to putting on MOPP gloves and overgloves.
- The clear plastic packaging material may be cut open or notched prior to sampling mission to allow easier access to components during the mission.
- Keep custody seal's backing in a continuous strip if possible. Having extra material available will aid in removal of custody seals from backing. Individually separated custody seals are extremely difficult to remove from backing when wearing MOPP gloves.
- Custody seals may not stick to Teflon jars. A custody seal is mandatory on the sealed edge of the Whirl–Pak bag.

A.2.2 Soil sample.

- a. Locate your sampling area.
- b. Using the following procedures, take samples from three points for each site (using a different jar at each point), one from each of the following points: 100 meters upwind, ground zero, and 100 meters downwind.

MIL–PRF–51200C(EA)

Appendix A

- c. Write the suspected chemical agent contamination (if known) and fill in the sample documentation.
- d. Remove a new pair of overgloves from the kit. Use scissors if necessary to open packaging. Place (wear) new overgloves over the MOPP gloves.
- e. Use scissors to open an individually wrapped scoop and a packet of jars. Open only one new jar at each point.
- f. Scoop a thin layer of top soil (not more than one-half inch deep) from a small area into the sample container. Fill the sample jar to at least 75% of its volume.
- g. Screw the cap on tightly. Optional: write identification information on custody seal and apply seal to jar. Remove the smallest bag (approximately 7" x 11") from the kit.
 - 1. Tear off top portion of bag along the perforated line.
 - 2. Using the white tabs, pull bag apart to open.
 - 3. Place jar in bag.
 - 4. Remove excess air. While holding the extended yellow metal tabs, whirl the bag three times to close (or roll down yellow edge tightly).
 - 5. Bend wire ends onto the bag to secure and store contents.
 - 6. Write identification information on custody seal and apply custody seal over rolled end end section of bag.
- h. Collect any other required samples from this site and prepare as indicated in steps A.2.2c to A.2.2g. Place up to 3 filled small bags into the large brown bag. After the three samples are placed in the large brown bag, remove excess air, seal the bag and roll down the excess material at the top of the outer bag. Wrap tape around the bag. Be sure to fold over end of tape on roll so you can get a hold of the end next time you use tape. Write on tape to identify type of sample in bag. Place all filled brown bags inside the drawstring bag.

A.2.3 Surface sample.

- a. Fill in the sample documentation.
- b. Place (wear) a new pair of overgloves, provided in the kit, over the MOPP gloves.
- c. Use scissors to open a packet of jars containing wipes.
- d. Open jar and use the tweezers to remove the wipe from the jar. Holding wipe with tweezers, blot the targeted surface with the wipe. Place the wipe back in the jar.
- e. Screw the cap on tightly. Optional: write identification information on custody seal and apply seal to jar. Remove the smallest bag from the kit.

MIL–PRF–51200C(EA)

Appendix A

1. Tear off top portion of bag along the perforated line.
2. Using the white tabs, pull bag apart to open.
3. Place jar in bag.
4. Remove excess air. While holding the extended yellow metal tabs, whirl the bag three times to close (or roll down yellow edge tightly).
5. Bend wire ends onto the bag to secure and store contents.
6. Write identification information on custody seal and apply custody seal over rolled end section of bag.

f. Collect any other required samples from this site and prepare as indicated in steps A.2.3a to A.2.3e. Place up to 3 filled small bags into the large brown bag. After the three samples are placed in the large brown bag, remove excess air, seal the bag and roll down the excess material at the top of the outer bag. Wrap tape around the bag. Be sure to fold over end of tape on roll so you can get a hold of the end next time you use tape. Write on tape to identify type of sample in bag. Place all filled brown bags inside the drawstring bag.

A.2.4 Liquid sample. This procedure describes a method for collecting samples of liquid held below or at the surface.

- a. Prepare the sample documentation.
- b. Place (wear) a new pair of overgloves, provided in the kit, over the MOPP gloves.
- c. Use scissors to open the packaging containing a syringe and extension tube and a packet of jars. Open only one new jar at each point.
- d. Attach extension tube to tip of syringe. Locate tip of tube at collection point. Pull back plunger to draw a maximum amount of suspect liquid into syringe.
- e. Position filled syringe over jar opening. Push in plunger to expel liquid into a jar.
- f. Repeat the process of collecting liquid and transferring it to the jar until the jar is filled to 75% of its total volume (approximately 2 fills with syringe).
- g. Screw the cap on tightly. Optional: write identification information on custody seal and apply seal to jar. Remove the smallest bag from the kit.
 1. Tear off top portion of bag along the perforated line.
 2. Using the white tabs, pull bag apart to open.
 3. Place jar in bag.
 4. Remove excess air. While holding the extended yellow metal tabs, whirl the bag three times to close (or roll down yellow edge tightly).
 5. Bend wire ends onto the bag to secure and store contents.

MIL–PRF–51200C(EA)

Appendix A

6. Write identification information on custody seal and apply custody seal over rolled end end section of bag.

h. Collect any other required samples from this site and prepare as indicated in steps A.2.4a to A.2.4g. Place up to 3 filled small bags into the large brown bag. After the three samples are placed in the large brown bag, remove excess air, seal the bag and roll down the excess material at the top of the outer bag. Wrap tape around the bag. Be sure to fold over end of tape on roll so you can get a hold of the end next time you use tape. Write on tape to identify type of sample in bag. Place all filled brown bags inside the drawstring bag.

A.2.5 Liquid sample, alternate method.

- a. Prepare the sample documentation.
- b. Place (wear) a new pair of overgloves, provided in the kit, over the MOPP gloves.
- c. Use scissors to open wrapped sample jars, gloves, and scoop. Open only one new jar at each point.
- d. Scoop approximately 70 ml of suspected contaminated liquid into a sample jar (fill jar to at least 75% of its total volume).
- e. Screw the cap on tightly. Optional: write identification information on custody seal and apply seal to jar. Remove the smallest bag from the kit
 1. Tear off top portion of bag along the perforated line.
 2. Using the white tabs, pull bag apart to open.
 3. Place jar in bag.
 4. Remove excess air. While holding the extended yellow metal tabs, whirl the bag three times to close (or roll down yellow edge tightly).
 5. Bend wire ends onto the bag to secure and store contents.
 6. Write identification information on custody seal and apply custody seal over rolled end end section of bag.

h. Collect any other required samples from this site and prepare as indicated in steps A.2.5a to A.2.5e. Place up to 3 filled small bags into the large brown bag. After the three samples are placed in the large brown bag, remove excess air, seal the bag and roll down the excess material at the top of the outer bag. Wrap tape around the bag. Be sure to fold over end of tape on roll so you can get a hold of the end next time you use tape. Write on tape to identify type of sample in bag. Place all filled brown bags inside the drawstring bag.

A.2.6 Vegetation sample.

- a. Fill in the sample documentation.
- b. Place (wear) a new pair of overgloves, provided in the kit, over the MOPP gloves.

MIL-PRF-51200C(EA)

Appendix A

- c. Use snips or scissors to open a packet of jars. Open only one new jar at each point.
- d. Grasp sample material with tweezers and use scissors to cut materials suspected of having surface contamination from a tree or bush. Transfer item to jar using the tweezers.
- e. Screw the cap on tightly. Optional: write identification information on custody seal and apply seal to jar. Remove the smallest bag from the kit.
 1. Tear off top portion of bag along the perforated line.
 2. Using the white tabs, pull bag apart to open.
 3. Place jar in bag.
 4. Remove excess air. While holding the extended yellow metal tabs, whirl the bag three times to close (or roll down yellow edge tightly).
 5. Bend wire ends onto the bag to secure and store contents.
 6. Write identification information on custody seal and apply custody seal over rolled end section of bag.
- f. Collect any other required samples from this site and prepare as indicated in steps A.2.6a to A.2.6e. Place up to 3 filled small bags into the large brown bag. After the three samples are placed in the large brown bag, remove excess air, seal the bag and roll down the excess material at the top of the outer bag. Wrap tape around the bag. Be sure to fold over end of tape on roll so you can get a hold of the end next time you use tape. Write on tape to identify type of sample in bag. Place all filled brown bags inside the drawstring bag.

STANDARDIZATION DOCUMENT IMPROVEMENT PROPOSAL

INSTRUCTIONS

1. The preparing activity must complete blocks 1, 2, 3, and 8. In block 1, both the document number and revision letter should be given.
2. The submitter of this form must complete blocks 4, 5, 6, and 7, and send to preparing activity.
3. The preparing activity must provide a reply within 30 days from receipt of the form.

NOTE: This form may not be used to request copies of documents, nor to request waivers, or clarification of requirements on current contracts. Comments submitted on this form do not constitute or imply authorization to waive any portion of the referenced document(s) or to amend contractual requirements.

I RECOMMEND A CHANGE:	1. DOCUMENT NUMBER	2. DOCUMENT DATE (YYYYMMDD)
3. DOCUMENT TITLE		
4. NATURE OF CHANGE <i>(Identify paragraph number and include proposed rewrite, if possible. Attach extra sheets as needed.)</i>		
5. REASON FOR RECOMMENDATION		
6. SUBMITTER		
a. NAME <i>(Last, First, Middle Initial)</i>	b. ORGANIZATION	
c. ADDRESS <i>(Include ZIP Code)</i>	d. TELEPHONE <i>(Include Area Code)</i> (1) Commercial (2) DSN <i>(If applicable)</i>	7. DATE SUBMITTED (YYYYMMDD)
8. PREPARING ACTIVITY		
a. NAME	b. TELEPHONE <i>(Include Area Code)</i> (1) Commercial (2) DSN	
c. ADDRESS <i>(Include ZIP Code)</i>	IF YOU DO NOT RECEIVE A REPLY WITHIN 45 DAYS, CONTACT: Defense Standardization Program Office (DLSC-LM) 8725 John J. Kingman Road, Suite 2533 Fort Belvoir, Virginia 22060-6221 Telephone (703) 767-6888 DSN 427-6888	