

INCH-POUND

MIL-PRF-44073G  
11 September 2009  
SUPERSEDING  
MIL-PRF-44073F  
4 September 2001

## PERFORMANCE SPECIFICATION

### PACKAGING OF FOOD IN FLEXIBLE POUCHES

This specification is approved for use by all Departments and Agencies of the Department of Defense.

#### 1. SCOPE

1.1 Scope. This specification covers the performance criteria for packaging materials and the packaging of food in flexible pouches to include the filling and hermetic sealing of the pouches and, when applicable, the packaging of the pouches into cartons.

1.2 Classification. Pouches are of the following types, styles and designs, as specified (see 6.2).

##### 1.2.1 Types.

Type I – Single Serving Pouch (SSP)

Type II – Institutional Size Pouch (ISP)

Comments, suggestions, or questions on this document should be addressed to US Army Research, Development and Engineering Command, Natick Soldier Research, Development and Engineering Center, RDNS-CFF, 15 Kansas St., Natick, MA 01760-5018 or emailed to [ray.valvano@us.army.mil](mailto:ray.valvano@us.army.mil). Since contact information can change, you may want to verify the currency of this address information using the ASSIST Online database at <http://assist.daps.dla.mil/>.

AMSC N/A

FSC 89GP

DISTRIBUTION STATEMENT A. Approved for public release; distribution is unlimited.

## MIL-PRF-44073G

### 1.2.2 Styles.

Style 1 – Rectangular pouch (figures 1 and 1A)

Style 2 – Shaped pouch with side spout (figure 4)

Style 3 – Shaped pouch with center spout (figure 5)

### 1.2.3 Designs.

Design A – Horizontal directional tear

## 2. APPLICABLE DOCUMENTS

2.1 General. The documents listed in this section are specified in sections 3, 4 or 5 of this specification. This section does not include documents cited in other sections of this specification or recommended for additional information or as examples. While every effort has been made to ensure the completeness of this list, document users are cautioned that they must meet all specified requirements of documents cited in sections 3, 4 or 5 of this specification, whether or not they are listed.

### 2.2 Government documents.

2.2.1 Specifications, standards, and handbooks. None.

2.2.2 Other government documents, drawings and publications. The following other Government documents, drawings, and publications form a part of this document to the extent specified herein. Unless otherwise specified, the issues of these documents are those cited in the solicitation or contract.

#### U.S. DEPARTMENT OF HEALTH AND HUMAN SERVICES

Federal Food, Drug and Cosmetic Act and regulations (21 Code of Federal Regulations (CFR), Parts 170-199)

(Copies of this document are available from [www.access.gpo.gov/nara](http://www.access.gpo.gov/nara) or Superintendent of Documents, ATTN: New Orders, P.O. Box 371954, Pittsburgh, PA 15250-7954.)

2.3 Non-Government publications. The following documents, drawings, and publications form a part of this document to the extent specified herein. Unless otherwise specified, the issues of these documents are those cited in the solicitation or contract.

#### AMERICAN SOCIETY FOR TESTING AND MATERIALS (ASTM)

## MIL-PRF-44073G

D 999 – Methods for Vibration Testing of Shipping Containers

D 1974 – Standard Practice for Methods of Closing, Sealing, and Reinforcing Fiberboard Boxes

D 3985 – Oxygen Gas Transmission Rate Through Plastic Film and Sheeting Using a Coulometric Sensor

D 4727/D 4727M – Standard Specification for Corrugated and Solid Fiberboard Sheet Stock (Container Grade) and Cut Shapes

D 5118/D 5118M – Standard Practice for Fabrication of Fiberboard Shipping Boxes

D 5276 – Test Method for Drop Test of Loaded Containers by Free Fall

F 372 – Standard Test Method for Water Vapor Transmission of Flexible Barrier Materials Using an Infrared Detection Technique

(Copies of these documents are available at [www.astm.org](http://www.astm.org) or from ASTM International, 100 Barr Harbor Drive, PO Box C700, West Conshohocken, PA 19428-2959)

2.4 Order of precedence. In the event of a conflict between the text of this document and the references cited herein, the text of this document takes precedence. Nothing in this document, however, supersedes applicable laws and regulations unless a specific exemption has been obtained.

### 3. REQUIREMENTS

#### 3.1 Performance characteristics.

3.1.1 Pouch material. The pouch material shall be capable of being fabricated into pouches. The material used for the pouch shall be generally recognized as safe (GRAS) for use with food in accordance with 21 CFR, Parts 170-199 or other standards and regulations. Recycled, recovered, or environmentally preferable materials should be used to the maximum extent possible, provided that the material meets or exceeds the operational and maintenance requirement, and promotes economically advantageous life cycle costs.

3.1.1.1 Oxygen transmission rate. The oxygen transmission rate ( $O_2TR$ ) of the material shall not exceed  $0.06 \text{ cc/m}^2/24 \text{ hrs/atm}$ .

## MIL-PRF-44073G

3.1.1.2 Water vapor transmission rate. The water vapor transmission Rate (WVTR) of the material shall not exceed 0.01 gm/m<sup>2</sup>/24 hrs.

3.1.1.3 Thermal processing. The pouches shall be capable of withstanding the process specified in the applicable food document. If the material used is a multi-layered laminate, it shall show no evidence of delamination after thermal processing.

3.1.2 Pouch configurations and dimensions. Pouch configurations and dimensions for 5 and 8 ounce Single Serving Pouch (SSP) pouches shall be as specified in figures 1, 1A, 2A, 4, 5 or 6, as applicable (see 6.2). Pouch configuration and dimensions for the Institutional Size Pouch (ISP) shall be as specified in figure 3 (see 6.2). Commercial pouches [packaging material, construction, and graphics (colors, design and labeling)] shall be submitted to the Contracting Officer for review and approval and to US Army Research, Development and Engineering Command, Natick Soldier Research, Development and Engineering Center, RDNS-CFF for review and recommendation.

3.1.2.1 Directional tear. The pouch material shall be modified (in one or more layers) to provide a straight tear along the lengthwise axis of the pouch.

### 3.1.3 Pouch filling.

3.1.3.1 Eight ounce pouch. Products requiring an average net weight of 8 ounces or less but more than 5 ounces shall be filled into an 8 ounce size pouch. Placeable products may be filled into an 8 ounce pouch.

3.1.3.2 Five ounce pouch. Products requiring an average net weight of 5 ounces or less shall be filled into a 5 ounce size pouch.

3.1.3.3 Institutional size pouch. Products requiring an average net weight ranging from 48 to 104 ounces shall be filled into an ISP.

### 3.1.4 Filled, sealed and thermoprocessed pouch.

3.1.4.1 Closure seal. The closure seal width shall be a minimum 2.5 mm. The closure seal shall be free of impression or design on the seal surface that would conceal or impair visual detection of seal defects. The closure seal shall be free of wrinkles, occluded matter, or evidence of entrapped moisture or grease that reduces the closure seal width to less than 1/16 inch at any location along its continuous path.

3.1.4.2 Residual gas volume. Residual gas volume in filled and sealed SSP pouches shall not exceed 20 cubic centimeters (cc), except pouches with five ounces of fruit shall not exceed 10 cc. Residual gas volume in the filled and sealed ISPs shall not exceed 250 cc.

## MIL-PRF-44073G

3.1.4.3 Internal pressure. The pouches shall be filled and hermetically sealed such that after thermal processing, the pouches shall withstand the applicable pressure for 30 seconds.

3.1.4.4 Camouflage. The color of outside surfaces of the SSP pouch, after thermal processing, shall contribute to field camouflage. For ISP, commercial pouches are acceptable.

3.1.4.5 Pouch defects. Filled, sealed and thermally processed pouches shall be free of damage (such as, but not limited to, tears, cuts, holes, or if a multi-layer laminate is used, abrasions through one or more layers in the pouch material, or leakage through any seal).

### 3.2 Environmental conditions.

3.2.1 Low temperature (Type I). After thermal processing, the filled and sealed SSP pouch shall withstand pouch abuse at 28°F with a survival rate of 75 percent.

3.2.2 High temperature (Type I). After thermal processing, the filled and sealed SSP pouch shall withstand pouch abuse at 160°F with a survival rate of 100 percent.

3.2.3 Standard temperature (Type II). After thermal processing, the filled and sealed ISP shall withstand pouch abuse at 72°F with a survival rate of 100 percent.

3.2.4 Frozen temperature (Type II). After thermal processing, the filled and sealed ISP shall withstand pouch abuse at -20°F with a survival rate of 75 percent.

3.3 Carton design. Cartons, when specified in the applicable food product document, shall meet the following criteria.

3.3.1 Carton design for 8 ounce size pouches (Type I). The SSP carton, when closed and sealed, shall completely enclose the pouch to prevent physical damage and entry of foreign matter.

3.3.2 Carton design for 5 ounce size pouches (Type I, Style 1). The SSP carton, when closed and sealed, shall completely enclose pouch to prevent physical damage and entry of foreign matter. Not applicable for Type I, Styles 2 or 3 pouches.

3.3.3 Carton color. The color of all carton surfaces shall be natural kraft, tan or dull gray.

3.3.4 Carton dimensions (Type I). The inside length and width dimensions of the SSP carton shall be equal to the outside length and width dimensions of the pouch. The carton depth shall be 5/8 inch ( $\pm$  1/16 inch).

3.3.5 Carton design (Type II). The ISP carton, when closed and sealed, shall enclose pouch to prevent physical damage. The carton may have open or closed ends.

MIL-PRF-44073G

3.3.6 Carton dimensions (Type II). The outside length, width and height of the ISP carton shall not exceed 12-13/16 by 10-3/4 by 2-1/8 inches.

3.4 Packaging of pouches in cartons.

3.4.1 Pouch in carton (Type I). Each SSP carton shall contain one flat, fully extended pouch.

3.4.2 Carton closure (Type I). Each SSP carton shall be securely closed. The closure shall have a bond strength greater than the fiber tear of the paperboard.

3.4.3 Pouch in carton (Type II). Each ISP carton shall contain one pouch. One end of ISP may be folded to accommodate fitting the pouch into the carton.

3.4.4 Carton closure (Type II). The top and bottom faces of the carton shall be compressed and the ends taped. The closure shall have a bond strength greater than the fiber tear of the fiberboard.

3.5 Carton label (Type II). The following instructions shall be correctly and legibly labeled on the ISP carton. Type size of the label shall be no smaller than shown below (printed on 8-1/2 by 11 inch paper), but can be larger.

**ATTENTION!**

**PROTECTIVE CARTON-DO NOT THROW AWAY**

**SAVE AND RE-USE TO PROTECT  
POUCH FROM DAMAGE**

**To Avoid Damaging Pouch:**

- 1. Keep Pouch in Carton Until Ready to Heat, Then Remove.**
- 2. Insert Pouch Back Into Carton After Heating.**
- 3. Always Use Cartons When Transporting Pouches in Insulated Food Containers.**
- 4. If Cartons Are Unavailable, Stack Pouches With Fiberboard Pads Between Pouches.**

In addition, the product name shall be correctly and legibly labeled on the carton.

## MIL-PRF-44073G

## 4. VERIFICATION

4.1 Conformance inspection. Conformance inspection shall include the examinations and tests in this section, as defined in the contract, performed on specified samples (see 6.2).

4.2 Performance characteristics testing. The pouch material, pouch and carton shall be tested for the performance characteristics listed in table I.

TABLE I. Verification methods.

Characteristic <u>1/</u>	Requirement	Verification
Oxygen transmission rate	3.1.1.1	4.5.1
Water vapor transmission rate	3.1.1.2	4.5.2
Thermal processing	3.1.1.3	4.5.3
Pouch configurations and dimensions	3.1.2	Figures
Directional tear	3.1.2.1	4.5.4
Residual gas volume	3.1.4.2	4.5.5
Internal pressure	3.1.4.3	4.5.6
Camouflage (Type I), as applicable	3.1.4.4	4.5.7
Low temperature (Type I)	3.2.1	4.5.8.1
High temperature (Type I)	3.2.2	4.5.8.2
Standard temperature (Type II)	3.2.3	4.5.8.3
Frozen temperature (Type II)	3.2.4	4.5.8.4

1/ Compliance to the requirements for O<sub>2</sub>TR, WVTR, pouch configurations and dimensions, thermal processing, environmental conditions and camouflage may be verified by Certificate of Conformance (CoC).

4.3 Examination of pouch. After thermal processing, the pouches shall be visually examined for compliance. Defects and defect classifications are listed in table II.

TABLE II. Filled, sealed and thermally processed pouch defects.

## MIL-PRF-44073G

Category				Defect
<u>Critical</u>	<u>Major A</u>	<u>Major B</u>	<u>Minor</u>	
			1	Swollen pouch.
			2	Tear, cut, hole, or if a multi-layered laminate is used, abrasion through one or more layers in the pouch material or leakage through any seal.
			3	Foldover wrinkle extending into the seal such that the closure seal is reduced to less than 1/16 inch.
			4	Presence of entrapped matter (for example, product, moisture, grease, etc.) that reduces the closure seal to less than 1/16 inch.
			5	Presence of delamination when a multi-layered laminate is used. <u>1/</u>
			6	Closure seal less than 1/16 inch at any location along its continuous path.
	101			Unclean pouch. <u>2/</u>
	102			Any impression or design on the seal surfaces which conceals or impairs visual detection of seal defects. <u>3/</u>
	103			Less than 3/16 inch between inside edge of tear notch and inside edge of seal.
	104			Closure seal not located as specified.

TABLE II. Filled, sealed and thermal processed pouch defects (continued)

Category				Defect
<u>Critical</u>	<u>Major A</u>	<u>Major B</u>	<u>Minor</u>	
	105			Labeling missing or incorrect or illegible.
		151		Presence of delamination when a multi-layered laminate is used. <u>1/</u>



## MIL-PRF-44073G

152	Closure seal width less than 2.5 mm but greater than 1/16 inch.
201	Presence of delamination when a multi-layered laminate is used. <u>1/</u>
202	Tear notches missing or not as specified.
203	Tear notches not located as specified.
204	Depth of tear notches not as specified.
205	Color of SSP does not contribute to field camouflage, when applicable.
206	Foreign odor.

---

1/ Delamination defect classification:

Critical - Evidence of outer ply delamination such that the adjacent ply in the pouch body is exposed or evidence of two ply delamination such that the food contact layer is exposed.

Major B - Delamination of the outer ply in the pouch seal area that can be propagated to expose the adjacent ply at the food product edge of the pouch after manual flexing of the delaminated area. To flex, the delaminated area shall be held between the thumb and forefinger of each hand with both thumbs and forefingers touching each other. The delaminated area shall then be rapidly flexed 10 times by rotating both hands in alternating clockwise-counter clockwise directions. Care shall be exercised when flexing delaminated areas near the tear notches to avoid tearing the pouch material. After flexing, the separated outer ply shall be grasped between thumb and forefinger and gently lifted toward the food product edge of the seal or if the separated area is too small to be held between thumb and forefinger, a number two stylus shall be inserted into the delaminated area and a gentle lifting force applied against the outer ply. If separation of the outer

ply can be made to extend to the product edge of the seal with no discernible resistance to the gentle lifting, the delamination shall be scored as a Major B defect. Additionally, spot delamination of the outer ply in the body of the pouch that is able to be propagated beyond its initial borders is also a Major B defect. To determine if the delaminated area is a defect, use the following procedure: Mark the outside edges of the delaminated area using a bold permanent marking open. Open the pouch and remove the contents. Cut the pouch transversely not closer than 1/4 inch (plus or minus 1/16 inch) from the delaminated area. The pouch shall be flexed in the area in question using the procedure described above. Any propagation of the delaminated

## MIL-PRF-44073G

area, as evidenced by the delaminated area exceeding the limits of the outlined borders, shall be scored as a Major B defect.

Minor - Minor delamination of the outer ply in the pouch seal area is acceptable and shall not be classified as a minor defect unless it extends to within 1/16 inch of the food product edge of the seal. All other minor outer ply delamination in the pouch seal area or isolated spots of delamination in the body of the pouch that do not propagate when flexed as described above shall be classified as minor.

2/ Scale or dust on the outside of pouches caused by retort water may be removed by washing. The following examples shall not be scored as defects for unclean:

a. Water spots.

b. On SSP, two or less specks of dried product each of which measure 1/8 inch by 1/8 inch or equivalent area, or less. On ISP, ten or less specks of dried product each of which measure 1/8 inch by 1/8 inch or equivalent area, or less.

c. Any foreign matter which presents no health hazard or no potential pouch damage and which readily falls off when pouch is lifted and shaken lightly.

d. Very thin film of grease, oil, or product residue which is discernible to touch, but not readily discernible by visual examinations.

e. Thin strips or drops of adhesive.

3/ If doubt exists as to whether or not the sealing equipment leaves an impression or design on the seal surfaces that could conceal or impair visual detection of seal defects, samples shall be furnished to the contracting officer for a determination as to acceptability.

4.4 Examination of pouch and carton. When applicable, the pouch and carton assembly shall be examined for compliance. Defects and defect classifications are listed in table III.

TABLE III. Pouch and carton assembly defects

Category			Defect
<u>Critical</u>	<u>Major</u>	<u>Minor</u>	
1			Tear, hole, or puncture through carton or open carton causing a hole in the pouch or obviously wet or stained carton due to leaking pouch.
	101		Tear or hole in carton exposing pouch to potential

MIL-PRF-44073G

damage.

102	Outer flaps of carton not closed.
103	Carton not clean.
104	SSP pouch body not in a flat, fully extended position in SSP carton.
105	Bond strength in SSP carton closure is not greater than fiber strength of paperboard of carton.
106	ISP pouch does not fit into the ISP carton. <u>1/</u>
201	Tear or hole in carton not exposing pouch to potential damage.
202	Color of carton not as specified.
203	Labeling missing or incorrect or illegible.
204	Outer flaps of SSP carton not closed to within 1/2 inch of either end.
205	The ISP carton not closed as specified.
206	Foreign odor.

---

1/ Pouches with a folded end shall not be scored as a defect.

#### 4.5 Tests.

4.5.1 Oxygen transmission rate. The oxygen transmission rate of the material shall be determined in accordance with ASTM D 3985, at 73°F and 50 % RH. Any oxygen transmission rate exceeding 0.06 cc/m<sup>2</sup>/24 hrs/atm shall be considered a test failure and shall be cause for rejection of the lot.

4.5.2 Water vapor transmission rate. The water vapor transmission rate of the material shall be determined in accordance with ASTM F 372, at 100°F and 90 % RH. Any water vapor transmission rate exceeding 0.01 gm/m<sup>2</sup>/24 hrs shall be considered a test failure and shall be cause for rejection of the lot.

## MIL-PRF-44073G

4.5.3 Thermal processing. Testing for thermal processing of the pouches shall be as follows: Pouches shall be filled with five, eight, or 48 to 104 ounces of water, as applicable to the pouch size, sealed and exposed to the same thermal processing conditions as required for filled and sealed pouches by the food product document. Following thermal processing, pouches shall be examined visually. Any pouch material defect as a result of thermal processing shall be considered a test failure and shall be cause for rejection of the lot.

4.5.4 Directional tear test. Using thumb and forefinger of each hand the pouch shall be gripped on each side of the tear notch opening at one end of the pouch. Twisting the two sides of the tear notch away from the notch center the pouch shall be torn open along the axis of the adjacent lengthwise side seal, (if pouch opening cannot be initiated on the initial attempt, the test shall be performed using the notch at the opposite end of the pouch). If the path of the resultant pouch tear line reduces the width of the remaining opened pouch to less than 3-1/2 inches when measured from the outside edge of the opposite side seal to the lowest point along the tear line, it shall be considered a test failure and shall be cause for rejection of the lot.

4.5.5 Residual gas volume test. The samples for test shall be opened under  $75^{\circ}\text{F} \pm 5^{\circ}\text{F}$  water and the gases shall be collected by water displacement in a graduated cylinder or other calibrated tube. The volume of the gases shall be reported to the nearest 0.1 cubic centimeter (cc) for SSP. Any residual gas volume exceeding 20 cc in SSP shall be considered a test failure, except any residual gas volume exceeding 10 cc in SSP pouches filled with fruit shall be considered a test failure. The volume of the gases shall be reported to the nearest 1 cc for ISP. Any residual gas volume exceeding 250 cc in ISP pouches shall be considered a test failure and shall be cause for rejection of the lot.

4.5.6 Internal pressure test. Internal pressure resistance shall be determined by pressurizing the pouches while they are restrained between two rigid plates. The plates shall be  $1/2$  inch  $\pm$   $1/16$  inch apart or 1 inch  $\pm$   $1/16$  inch apart for SSP, or 2 inches  $\pm$   $1/16$  inch apart for ISP. If a three-seal tester (one that pressurizes the pouch through an open end) is used, the closure seal shall be cut off for testing the side and bottom seals of the pouch; for testing of the closure seal, the bottom seal shall be cut off. The pouches shall be emptied prior to testing. If a four-seal tester (designed to pressurize filled pouches by use of a hypodermic needle through the pouch wall) is used, all four seals can be tested simultaneously. For SSP, the pressure shall be 20 psig for the  $1/2$  inch plate distance and 12 psig for the 1 inch plate distance. For ISP, the pressure shall be 10 psig for the 2 inch plate distance. Pressure shall be applied gradually until pressure set point is reached. The pressure set point shall be held constant for 30 seconds and then released. The pouches shall then be examined for separation or yield of the seals. Any rupture of the pouch or evidence of seal separation greater than  $1/16$  inch in the pouch manufacturer's seal shall be considered a test failure. Any seal separation that reduces the effective closure seal width to less than  $1/16$  inch (see table II) shall be considered a test failure and shall be cause for rejection of the lot.

4.5.7 Camouflage (Type I). External visible color of the outside surfaces of the SSP

## MIL-PRF-44073G

pouch material after thermal processing shall conform to the range of the government approved and standardized color swatches. Standardized swatch samples have been provided to and are on file with each contractor, each material supplier, USDA, Natick, and DSCP. Visibly match the outside surface of the pouch material to the range of colors of the standardized color swatch samples. Failures shall be classified as minor defects.

#### 4.5.8 Environmental conditions.

4.5.8.1 Low temperature (Type I). Fill the SSP pouches with water, seal and thermal process. After thermal processing, place pouches in paperboard cartons. Condition the unit packs in an atmosphere uniformly maintained at  $28^{\circ}\text{F} \pm 2^{\circ}\text{F}$  for a period of 48 hours. During exposure, position the unit packs to allow free circulation of air around each pack. Conduct a pouch abuse test while still in the frozen state using the test apparatus shown in figure 2. For eight ounce unit packs, the drop height shall be 40 inches; for five ounce unit packs, the drop height shall be 64 inches. Drop each unit pack twice, once on each end. Recondition tested unit packs to ambient temperature for at least 24 hours, remove pouches from cartons and examine visually. Any pouch leakage shall be considered a test failure and shall be cause for rejection of the lot.

4.5.8.2 High temperature (Type I). Fill the SSP pouches with water, seal and thermal process. After thermal processing, package pouches in paperboard cartons. Condition the unit packs in an atmosphere uniformly maintained at  $160^{\circ}\text{F} \pm 2^{\circ}\text{F}$  for a period of 48 hours. During exposure, position the unit packs to allow free circulation of air around each pack. Conduct a pouch abuse test using the test apparatus shown in figure 2. For eight ounce unit packs, the drop height shall be 40 inches; for five ounce unit packs, the drop height shall be 64 inches. Drop each unit pack twice, once on each end. Recondition tested unit packs to ambient temperature for at least 24 hours, remove pouches from cartons and examine visually. Any pouch leakage shall be considered a test failure and shall be cause for rejection of the lot.

4.5.8.3 Standard temperature (Type II). Each ISP pouch, filled with either water or a representative food product and processed as specified in the applicable food document, shall be inserted into the carton. Four filled, sealed and thermal processed ISP pouches shall be packed in a fiberboard box conforming to style RSC-L of ASTM D 5118. The fiberboard shall conform to type CF, class D, variety SW, grade 275 of ASTM D 4727/D 4727M, Standard Specification for Corrugated and Solid Fiberboard Sheet Stock (Container Grade) and Cut Shapes. The box shall be closed in accordance with ASTM D 1974. Condition the box of four ISPs in an atmosphere uniformly maintained at  $72^{\circ}\text{F} \pm 2^{\circ}\text{F}$  for a period of 48 hours. Conduct a drop test in accordance with ASTM D 5276, Ten Drop Cycle at a height of 21 inches. Immediately after completion of the drop test, conduct a vibration test (on the same box of four ISPs) in accordance with ASTM D 999, at 268 RPM (4.5 Hz) for a period of one hour. Remove ISPs from the box and examine visually. Any cracked, split or leaking ISP at any location, or tear, hole, or puncture through the carton causing a hole in the ISP; or wet or stained carton due to one or more leaking ISPs; or any evidence of food product leakage from ISP shall be considered a test failure and shall be cause for rejection of the lot.

## MIL-PRF-44073G

4.5.8.4 Frozen temperature (Type II). Prepare the box of four ISPs as specified in 4.5.8.3, but condition in an atmosphere uniformly maintained at  $-20^{\circ}\text{F} \pm 2^{\circ}\text{F}$  for a period of 48 hours. While still in frozen state, conduct drop and vibration tests as specified in 4.5.8.3. Remove ISPs from the box and allow to fully thaw prior to visual examination. Any cracked, split or leaking ISP at any location, or tear, hole, or puncture through the carton causing a hole in the ISP; or wet or stained carton due to one or more leaking ISPs; or any evidence of food product leakage from ISP shall be considered a test failure and shall be cause for rejection of the lot.

4.5.9 Carton closure bond strength. Compliance with required bond strength in carton closure shall be verified by visually examining the paperboard flaps or the fiberboard sleeve for evidence of fiber tear after opening. Absence of fiber tear shall be considered a test failure and shall be cause for rejection of the lot.

## 5. PACKAGING

This section is not applicable to this specification.

## 6. NOTES

(This section contains information of a general or explanatory nature that may be helpful, but is not mandatory.)

6.1 Intended use. The requirements for the packaging of food in flexible pouches cited by this specification are intended for use in the production of retort food products for individual rations.

6.2 Acquisition requirements. Acquisition documents must specify the following:

- a. Title, number, and date of the specification.
- b. Type, style, and design required (see 1.2).
- c. Conformance inspection (see 4.1).
- d. Pouch sizes for SSP (see 3.1.2 and figures).
- e. Pouch size for ISP (see 3.1.2 and figure 3).

6.3 Thermal processed products. The preparation and thermal processing of foods in hermetically sealed containers and finished product inspection should be established, controlled and verified by the processor in accordance with FDA (CFR Title 21 Part 113: Low Acid Canned Foods and Part 114: Acidified Foods) and USDA (CFR Title 9 Part 302 Subpart G: Canned Meat and Poultry Products) regulations.

## MIL-PRF-44073G

6.4 Pouch material.

6.4.1 Type I pouch material. The US Army Research, Development, and Engineering Command, Natick Soldier Research, Development, and Engineering Center has found that for preformed SSP pouches, a material structure consisting of, from inside to outside, 0.003 to 0.004 inch thick polyolefin, 0.00035 to 0.0007 inch thick aluminum foil, 0.0006 inch thick biaxially oriented polyamide-type 6, and 0.0005 inch thick polyester meets the performance criteria of this specification. Alternatively, the aluminum foil layer and the biaxially oriented polyamide layer may be in either order. For the formed, tray-shaped body of a horizontal form-fill-seal (HFFS) SSP pouch, it has been found that a material structure consisting of, from inside to outside, 0.003 to 0.004 inch thick polyolefin, 0.0006 inch thick biaxially oriented polyamide-type 6, 0.0015 to 0.00175 inch thick aluminum foil and 0.0010-0.0014 inch thick oriented polypropylene meets the performance criteria of this specification. For the lidding material for the HFFS SSP pouch, it has been found that a material structure consisting of, from inside to outside 0.003 to 0.004 inch thick polyolefin, 0.00035 to 0.0007 inch thick aluminum foil and 0.0005 to 0.00075 inch thick polyester meets the performance criteria of this specification. The above values and ranges expressed for the thickness of thin gauge plastic films and aluminum foil are nominal values. A plus or minus 20% tolerance is typical for thin gauge plastic film thickness measurements and a plus or minus 10% tolerance is typical for aluminum foil thickness measurements.

6.4.2 Type II pouch material. The US Army Research, Development, and Engineering Command, Natick Soldier Research, Development, and Engineering Center has found that for preformed ISP pouches, a material 5-layer structure consisting of, from inside to outside, 0.004 inch thick polyolefin, 0.00098 inch thick biaxially oriented polyamide, 0.00035 inch thick aluminum foil, 0.00059 inch thick biaxially oriented polyamide, and 0.00047 inch thick polyester meets the performance criteria of this specification. The above values and ranges expressed for the thickness of thin gauge plastic films and aluminum foil are nominal values. A plus or minus 20% tolerance is typical for thin gauge plastic film thickness measurements and a plus or minus 10% tolerance is typical for aluminum foil thickness measurements.

6.5 Carton design and material.

6.5.1 Type I Carton design and material. The US Army Research, Development, and Engineering Command, Natick Soldier Research, Development, and Engineering Center has found that a SSP carton design and material conforming to variety I, style I, type A, class a or style XIV, group I or II of PPP-B-566, Boxes, Folding, Paperboard, except that the carton may be made of 16-point bending chips, kraft lined chips or unbleached solid sulfate paperboard or of 17-point low density kraft paperboard having a minimum basis weight for the bending chips and the kraft lined chipboard of 60 pounds per 1000 square feet, a minimum basis weight for the unbleached solid sulfate board of 55 pounds per 1000 square feet or a minimum basis weight for the low density kraft paperboard of 48 pounds per square feet meets the performance criteria of this specification.

## MIL-PRF-44073G

6.5.2 Type II Carton design and material. It has been found that a ISP carton constructed of grade 275 fiberboard in accordance with ASTM D 4727/D 4727M, oriented with flutes parallel to the carton width, jointed and hot melt glued along either the vertical length or bottom face of the carton, and then ends closed and compressed and securely taped across the open ends of the carton at their midpoints meets the performance criteria of this specification.

### 6.6 Subject term (key word) listing.

First Strike Ration® (FSR®)  
Humanitarian Daily Ration  
Meal, Ready-to-Eat™ (MRE™)  
Operational rations  
Institutional Size  
Single Serving

6.7 Changes from previous issue. Marginal notations are not used in this revision to identify changes with respect to the previous issue due to the extent of the changes.



MIL-PRF-44073G

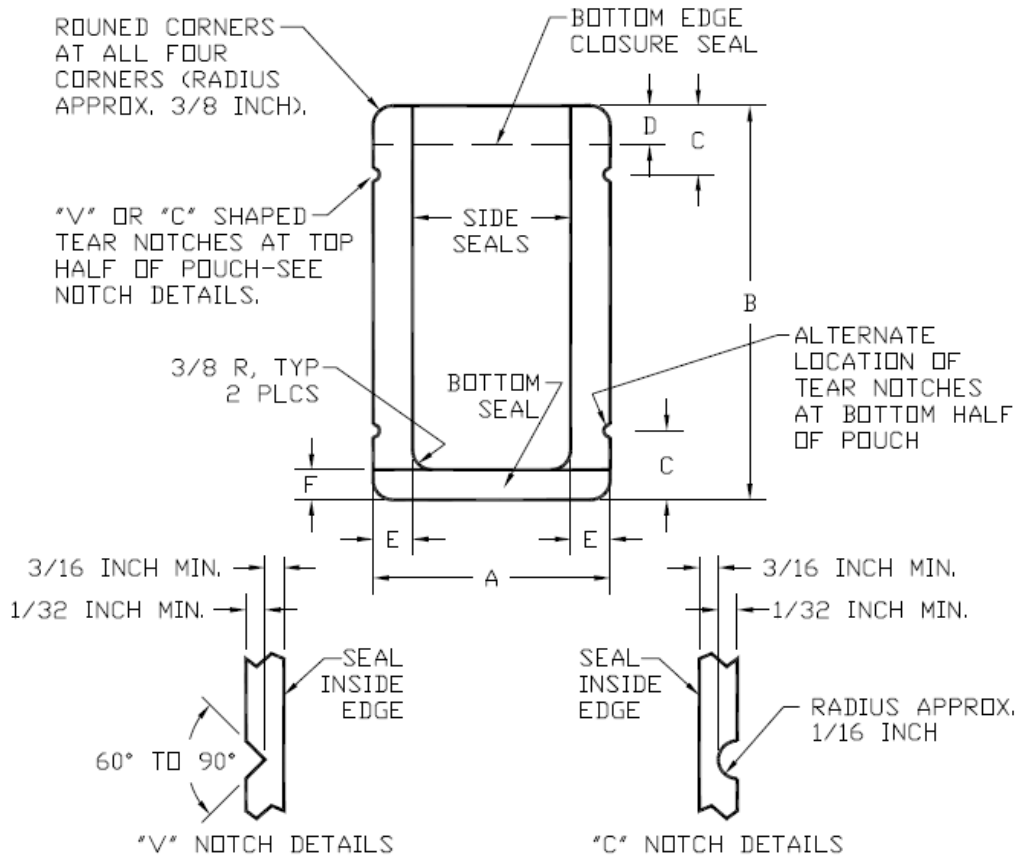

POUCH SIZES	DIMENSIONS IN INCHES					
	A	B	C	D	E	F
5 OUNCE SIZE	4 3/4	6 1/16 TO 6 1/4	1 (± 1/16)	3/4 MAX.	7/32 MIN.	1/8 MIN.
	(+ 1/16 - 1/8)	6 1/4 TO 7 3/8	1 1/2 ± 1/16	1 MAX.		

FIGURE 1. Single Serving Pouch

MIL-PRF-44073G

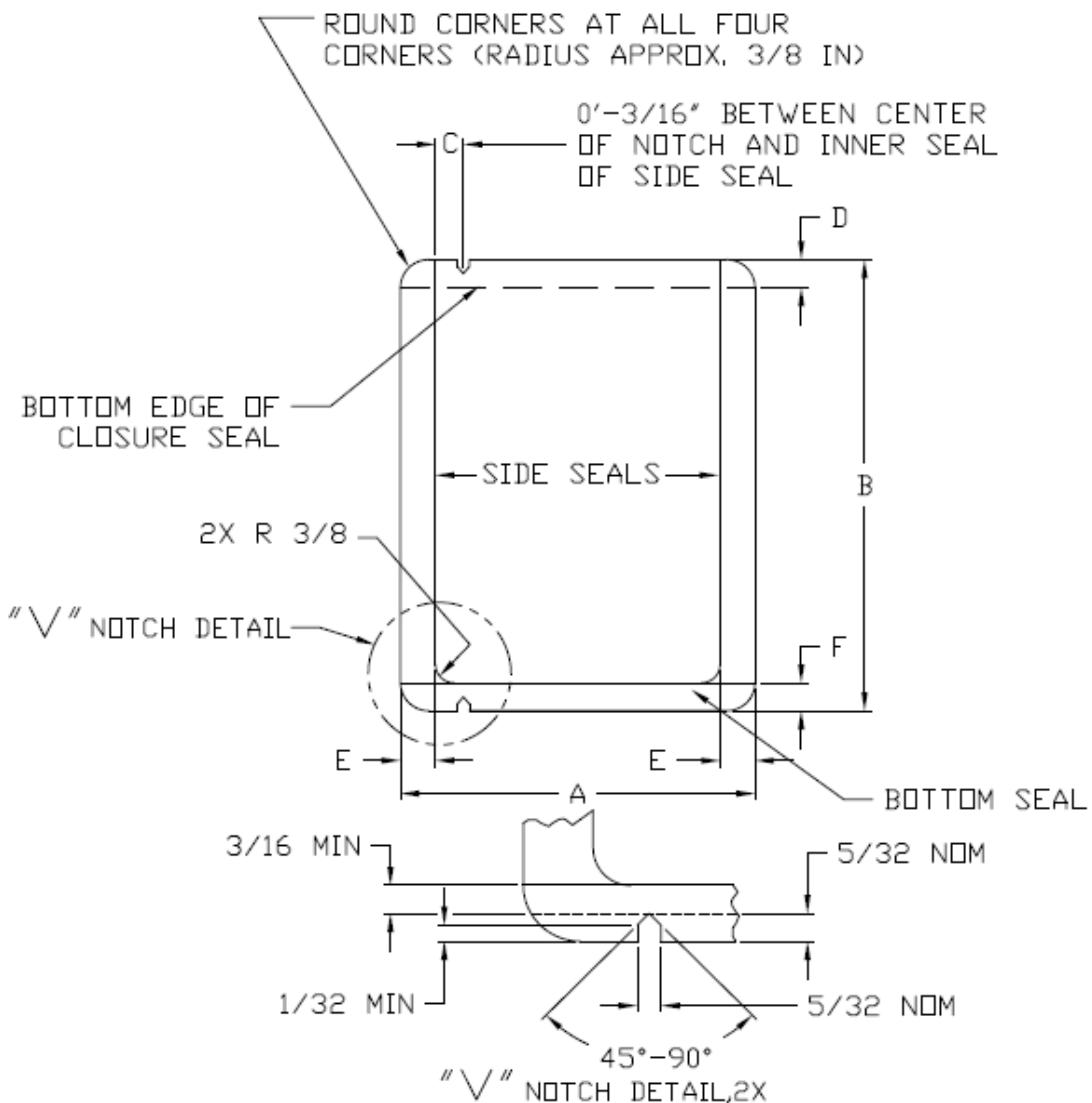

POUCH SIZES	DIMENSION IN INCHES					
	A	B	C	D	E	F
5 OUNCE SIZE 1/	4 3/4 (+1/16 -1/8)	6 1/16 TO 6 1/4	0-3/16	3/4 MAX	7/32 MIN	1/8 MIN
		6 1/4 TO 7 3/8	0-3/16	1 MAX		

FIGURE 1A. Directional Tear Pouch

MIL-PRF-44073G

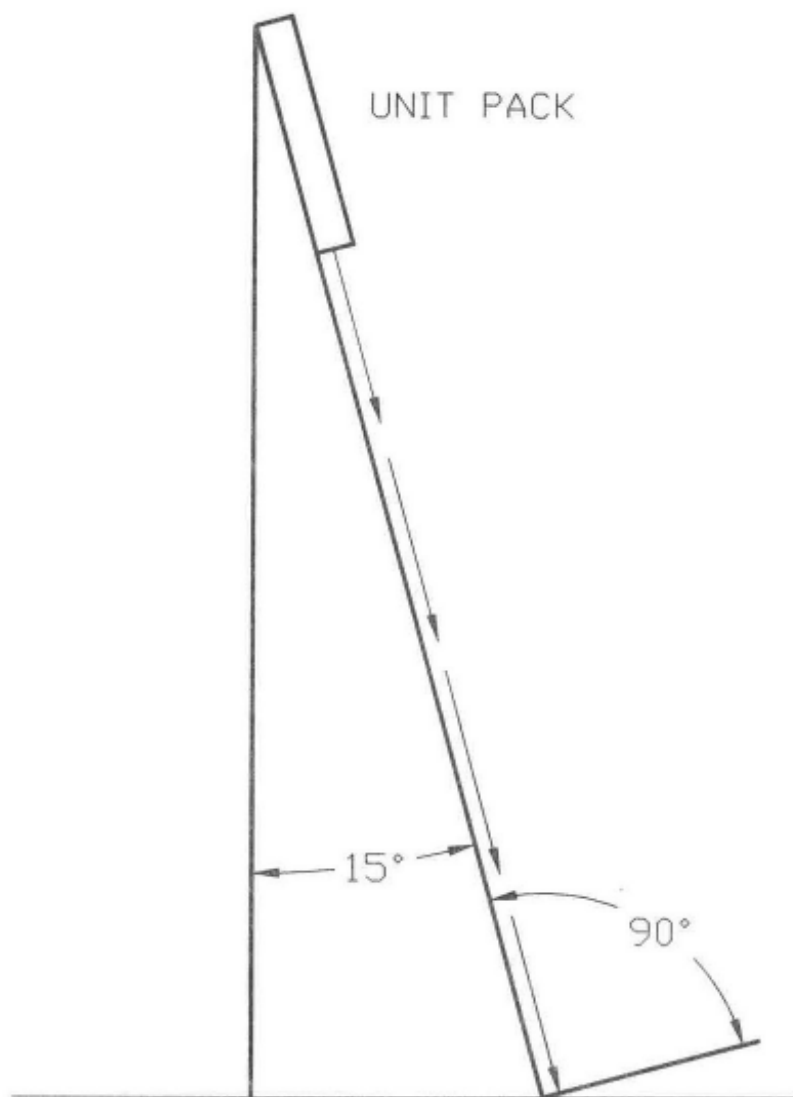

FIGURE 2  
POUCH ABUSE TEST APPARATUS

MIL-PRF-44073G

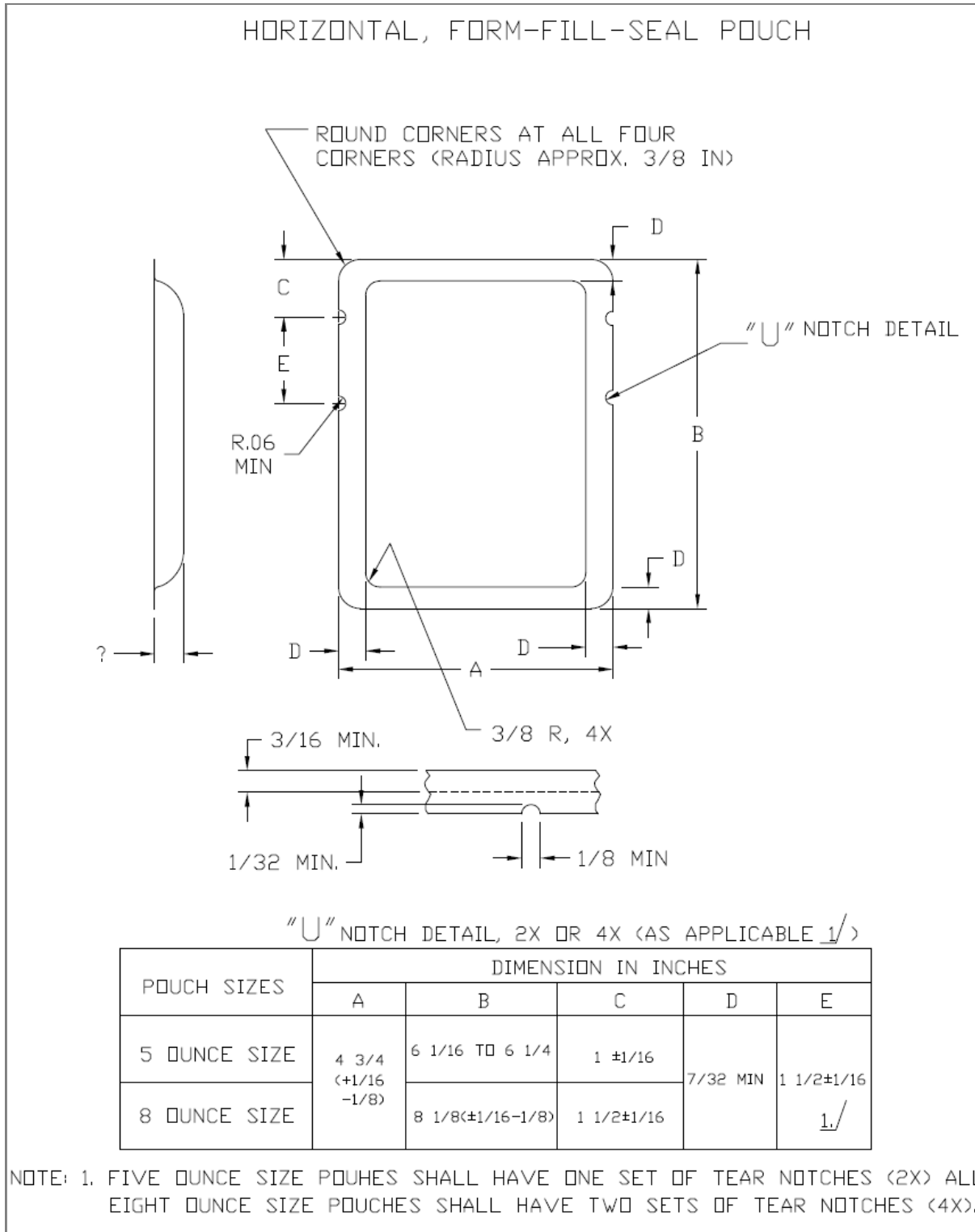

FIGURE 2A. Horizontal Form-Fill-Seal Pouch

MIL-PRF-44073G

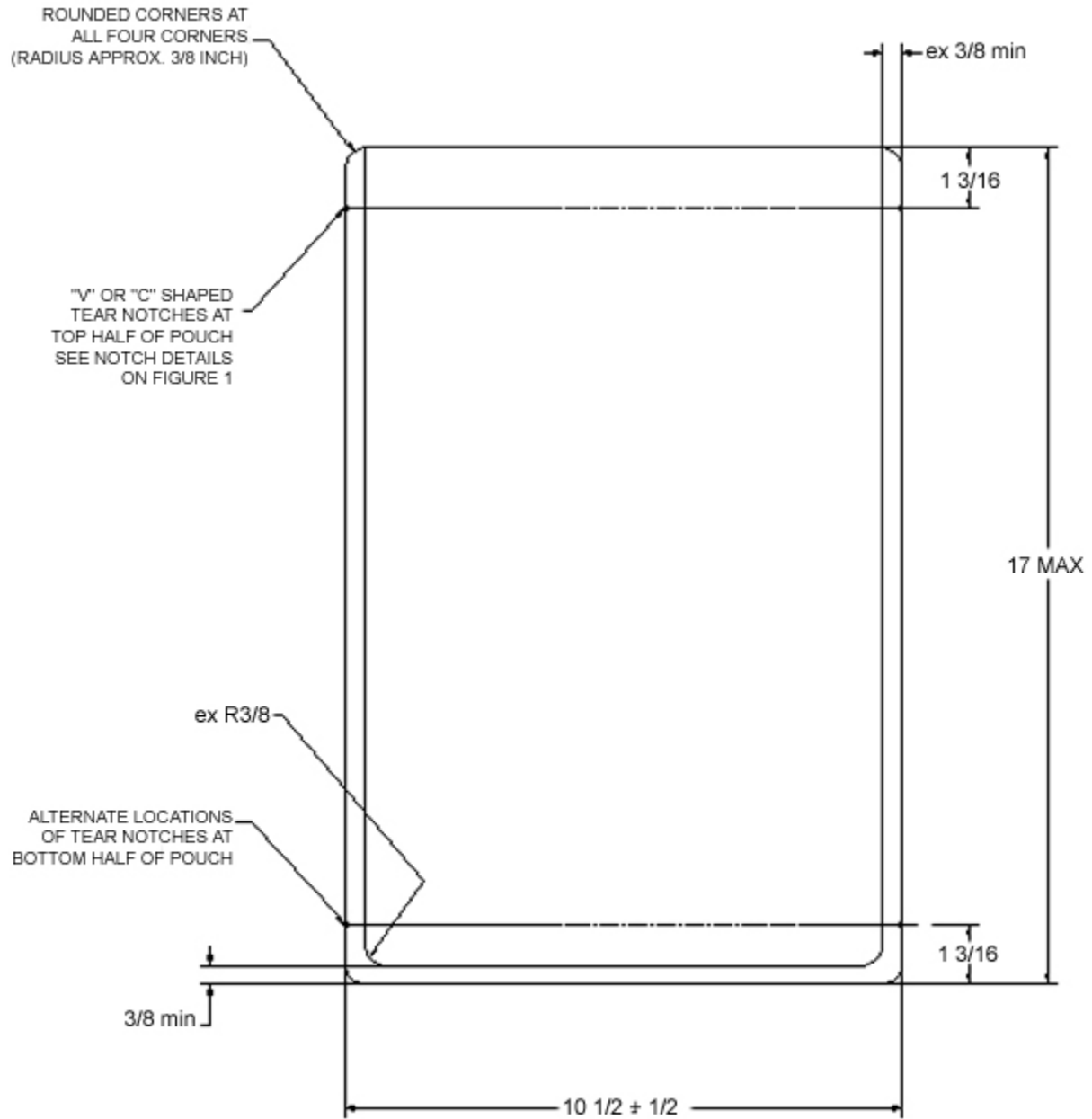

FIGURE 3. Institutional Size Pouch  
(Not actual size)

MIL-PRF-44073G

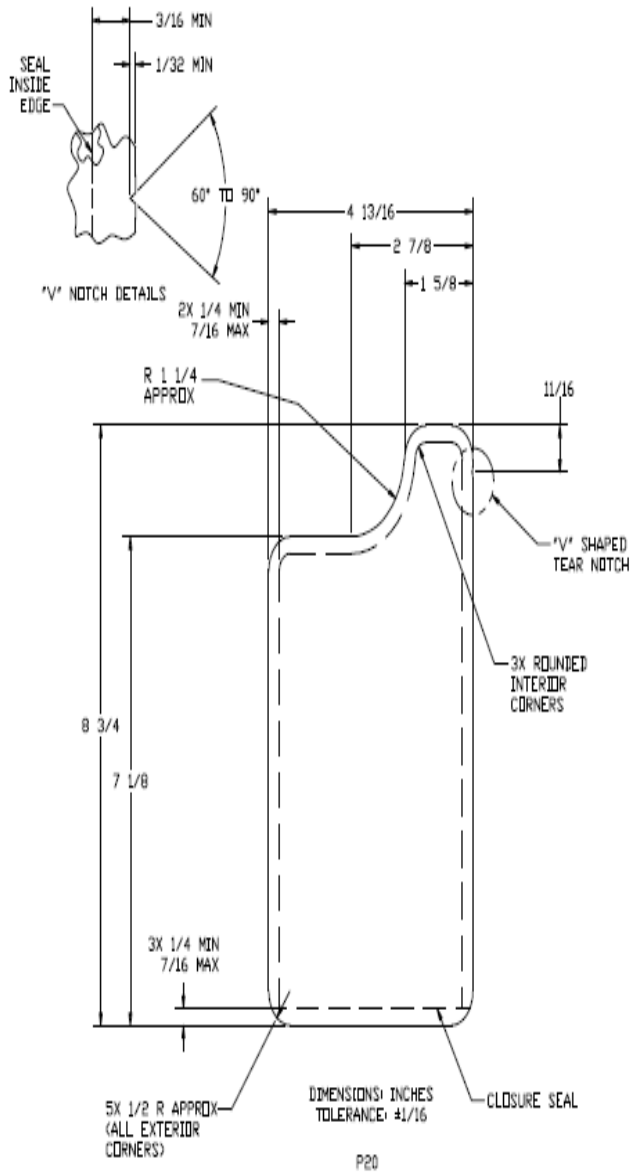

FIGURE 4. Side Spout Pouch

### MIL-PRF-44073G

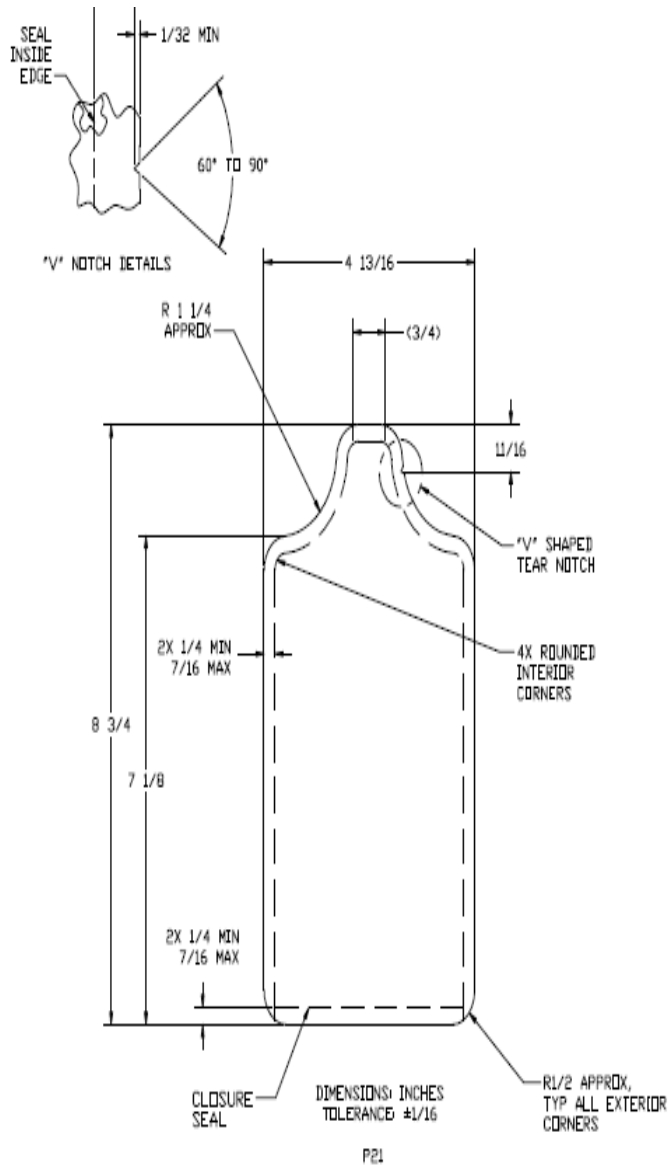

FIGURE 5. Center Spout Pouch

MIL-PRF-44073G

Custodians:

Army - GL  
Navy - SA  
Air Force - 35

Preparing activity:

Army - GL

(Project 89GP-2008-002)

Review activities:

Army - MD, QM  
Navy - MC  
DLA - SS

NOTE: The activities listed above were interested in this document as of the date of this document. Since organizations and responsibilities can change, you should verify the currency of the information above using ASSIST Online database at <http://assist.daps.dla.mil/>.