

INCH-POUND

MIL-PRF-44073F
4 September 2001
SUPERSEDING
MIL-PRF-44073E
9 February 1996

PERFORMANCE SPECIFICATION

PACKAGING OF FOOD IN FLEXIBLE POUCHES

This specification is approved for use by all Departments and Agencies of the Department of Defense.

1. SCOPE

1.1 Scope. This specification covers the performance criteria for packaging materials and the packaging of food in flexible pouches to include the filling and hermetic sealing of the pouches, the thermal processing of the filled and sealed pouches for commercial sterility, and the unit packing of the pouches into cartons.

1.2 Classification. Packaging and thermal processing of product will be of the following classes, as specified (see 6.1).

Class 1 - For meat, poultry, and fish with sauce and gravy

Class 2 - For vegetables with sauces

Class 3 - For meat and poultry in loaf, slice, or solid form

Class 4 - For fruit

Beneficial comments (recommendations, additions, deletions) and any pertinent data which may be of use in improving this document should be addressed to: Commander, U.S. Army Soldier and Biological Chemical Command, Natick Soldier Center, ATTN: AMSSB-RCF-F(N), Natick, MA 01760-5018 by using the self-addressed Standardization Document Improvement Proposal (DD Form 1426) appearing at the end of this document or by letter.

AMSC N/A

FSC 89GP

DISTRIBUTION STATEMENT A. Approved for public release; distribution is unlimited.

MIL-PRF-44073F

2. APPLICABLE DOCUMENTS

2.1 General. The documents listed in this section are specified in section 4 of this specification. This section does not include documents cited in other sections of this specification or recommended for additional information or as examples. While every effort has been made to ensure the completeness of this list, document users are cautioned that they must meet all specified requirements documents cited in section 4 of this specification, whether or not they are listed.

2.2 Government documents. None.

2.3 Non-Government publications. The following documents form a part of this document to the extent specified herein. Unless otherwise specified, the issues of the documents which are DoD adopted are those listed in the issue of the DoDISS cited in the solicitation. Unless otherwise specified, the issues of documents not listed in the DoDISS are the issues of the documents cited in the solicitation (see 6.1).

AMERICAN SOCIETY FOR TESTING AND MATERIALS (ASTM)

D 3985 - Oxygen Gas Transmission Rate Through Plastic Film and Sheeting Using a Coulometric Sensor

F 372 - Standard Test Method for Water Vapor Transmission of Flexible Barrier Materials Using an Infrared Detection Technique

(Application for copies should be addressed to the American Society for Testing and Materials (ASTM), 100 Barr Harbor Drive, West Conshohocken, PA 19428)

2.4 Order of precedence. In the event of a conflict between the text of this document and the references cited herein, the text of this document takes precedence. Nothing in this document, however, supersedes applicable laws and regulations unless a specific exemption has been obtained.

3. REQUIREMENTS

3.1 Performance characteristics.

3.1.1 Pouch material.

3.1.1.1 Fabrication. The pouch material shall be capable of being fabricated into pouches as specified in 3.1.2.

3.1.1.2 Oxygen transmission rate. The oxygen transmission rate (O₂TR) of the material shall not exceed 0.06 cc/m²/24 hrs/atm.

3.1.1.3 Water vapor transmission rate. The water vapor transmission Rate (WVTR) of the

MIL-PRF-44073F

material shall not exceed 0.01 gm/m²/24 hrs.

3.1.1.4 Thermal processing. The material when fabricated into pouches shall be capable of withstanding the thermal process specified in 3.1.5. If the material used is a multi-layered laminate, it shall show no evidence of delamination after thermal processing when examined in accordance with 4.2.

3.1.1.5 Environmental conditions.

3.1.1.5.1 Low temperature. After thermal processing, the filled and sealed pouch shall withstand pouch abuse at 28⁰F with a survival rate of 75 percent when tested in accordance with 4.3.4.1.

3.1.1.5.2 High temperature. After thermal processing, the filled and sealed pouch shall withstand pouch abuse at 160⁰F with a survival rate of 100 percent when tested in accordance with 4.3.4.2.

3.1.1.6 Camouflage. The color of outside surfaces of the pouch, before and after thermal processing, shall contribute to field camouflage.

3.1.2 Pouch configurations and dimensions. Pouch configurations and dimensions for 5 and 8 ounce pouches shall be as specified in figure 1 (see 6.1).

3.1.3 Pouch filling.

3.1.3.1 Eight ounce pouch. Products requiring an average net weight of 8 ounces or less but more than 5 ounces shall be filled into an 8 ounce size pouch. Placeable products may be filled into an 8 ounce pouch.

3.1.3.2 Five ounce pouch. Products requiring an average net weight of 5 ounces or less shall be filled into a 5 ounce size pouch.

3.1.4 Pouch sealing.

3.1.4.1 Residual gas. Residual gas volume in the filled and sealed pouches shall not exceed 10 cubic centimeters in pouches packed with Class 4 products, nor shall the residual gas volume exceed 20 cubic centimeters in pouches packed with Class 1, Class 2, or Class 3 products, when tested in accordance with 4.3.6.

3.1.4.2 Closure seal. The closure seal shall be free of impression or design on the seal surface that would conceal or impair visual detection of seal defects. The closure seal shall be free of wrinkles, occluded matter, or evidence of entrapped moisture or grease that reduces the closure seal width to less than 1/16 inch at any location along its continuous path when examined in accordance with 4.2.

MIL-PRF-44073F

3.1.4.3 Internal pressure. The pouches shall be filled and hermetically sealed such that after thermal processing, the pouches shall withstand 20 psig for 30 seconds when tested in accordance with 4.3.7.

3.1.5 Thermal processing. Filled and sealed pouches shall be thermally processed as specified in the applicable food product document.

3.1.5.1 Commercial sterility. Thermally processed pouches shall be free of swelling or microbial activity when tested in accordance with 4.3.8.

3.1.5.2 Pouch defects. Filled and sealed thermally processed pouches shall be free of damage (tears, cuts, holes, or if a multi-layer laminate is used, abrasions through one or more layers in the pouch material, or leakage through any heat seal) when examined in accordance with 4.2.

3.1.6 Carton design.

3.1.6.1 Carton design for 8 ounce size pouches. The carton, when closed and sealed, shall completely enclose the pouch to prevent physical damage and entry of foreign matter when examined in accordance with 4.2.1.

3.1.6.2 Carton design for 5 ounce size pouches. The carton, when closed and sealed, shall completely enclose pouch to prevent physical damage and entry of foreign matter when examined in accordance with 4.2.1.

3.1.6.3 Carton color. The color of all inside and outside carton surfaces shall be natural kraft, tan or dull gray.

3.1.6.4 Carton dimensions. The inside length and width dimensions of the carton shall be equal to the outside length and width dimensions of the pouch. The carton depth shall be 5/8 inch (\pm 1/16 inch).

3.1.7 Unit packing of pouches in cartons.

3.1.7.1 Pouch in carton. Each carton shall contain one flat, fully extended pouch.

3.1.7.2 Carton closure. Each carton shall be securely closed. The closure shall have a bond strength greater than the fiber tear of the paperboard when examined in accordance with 4.3.9.

4. VERIFICATION

4.1 Conformance inspection. Conformance inspection shall include the examinations of 4.2 and 4.2.1, and the tests of 4.1.1, and 4.3.1 through 4.3.9.

4.1.1 Pouch material testing. The pouch material shall be tested for the performance characteristics listed in table I.

MIL-PRF-44073F

TABLE I. Pouch material tests

Characteristic <u>1/</u>	Requirement paragraph	Test method
Oxygen transmission rate	3.1.1.2	4.3.1
Water vapor transmission rate	3.1.1.3	4.3.2
Thermal processing	3.1.1.4	4.3.3
Low temperature	3.1.1.5	4.3.4.1
High temperature	3.1.1.5	4.3.4.2
Camouflage	3.1.1.6	4.3.5

1/ In lieu of testing, determination of compliance to O₂TR, WVTR, environmental conditions, and camouflage requirements may be ascertained by examination of records, invoices, or other valid documents. In addition, compliance to the requirements for outside pouch dimensions and dimensions of manufacturer's seals may be verified by certificate of conformance.

4.2 Examination of pouch. After thermal processing, the pouches shall be visually examined for compliance with the requirements specified in 3.1.1, 3.1.2, 3.1.3, 3.1.4, and 3.1.5. Defects and defect classifications are listed in table II.

TABLE II. Filled, sealed and thermal processed pouch defects

Category				Defect
<u>Critical</u>	<u>Major A</u>	<u>Major B</u>	<u>Minor</u>	
1				Swollen pouch.
2				Tear, cut, hole, or if a multi-layered laminate is used, abrasion through one or more layers in the pouch material or leakage through any heat seal.
3				Foldover wrinkle extending into the seal such that the closure seal is reduced to less than 1/16 inch.
4				Presence of entrapped matter (for example, product, moisture, grease, etc.) that reduces the closure seal to less than 1/16 inch.

MIL-PRF-44073F

TABLE II. Filled, sealed and thermal processed pouch defects (cont'd)

Category				Defect
<u>Critical</u>	<u>Major A</u>	<u>Major B</u>	<u>Minor</u>	
5				Presence of delamination when a multi-layered laminate is used. <u>1/</u>
	101			Unclean pouch. <u>2/</u>
	102			Any impression or design on the heat seal surfaces which conceals or impairs visual detection of seal defects. <u>3/</u>
	103			Less than 3/16 inch between inside edge of tear notch and inside edge of seal.
	104			Closure seal not located as specified.
		151		Presence of delamination when a multi-layered laminate is used. <u>1/</u>
		152		Closure seal width not as specified.
			201	Presence of delamination when a multi-layered laminate is used. <u>1/</u>
			202	Tear notches missing, or not as specified.
			203	Tear notches not located as specified.
			204	Depth of tear notches not as specified.
			205	Color does not contribute to field camouflage.

1/ Delamination defect classification:

Critical - Evidence of outer ply delamination such that the adjacent ply in the pouch body is exposed or evidence of two ply delamination such that the food contactant layer is exposed.

Major B - Delamination of the outer ply in the pouch seal area that can be propagated to expose the

MIL-PRF-44073F

adjacent ply at the food product edge of the pouch after manual flexing of the delaminated area. To flex, the delaminated area shall be held between the thumb and forefinger of each hand with both thumbs and forefingers touching each other. The delaminated area shall then be rapidly flexed 10 times by rotating both hands in alternating clockwise-counter clockwise directions. Care shall be exercised when flexing delaminated areas near the tear notches to avoid tearing the pouch material. After flexing, the separated outer ply shall be grasped between thumb and forefinger and gently lifted toward the food product edge of the seal or if the separated area is too small to be held between thumb and forefinger, a number two stylus shall be inserted into the delaminated area and a gentle lifting force applied against the outer ply. If separation of the outer ply can be made to extend to the product edge of the seal with no discernible resistance to the gentle lifting, the delamination shall be scored as a Major B defect. Additionally, spot delamination of the outer ply in the body of the pouch that is able to be propagated beyond its initial borders is also a Major B defect. To determine if the delaminated area is a defect, use the following procedure: Mark the outside edges of the delaminated area using a bold permanent marking open. Open the pouch and remove the contents. Cut the pouch transversely not closer than 1/4 inch (plus or minus 1/16 inch) from the delaminated area. The pouch shall be flexed in the area in question using the procedure described above. Any propagation of the delaminated area, as evidenced by the delaminated area exceeding the limits of the outlined borders, shall be scored as a Major B defect.

Minor - Minor delamination of the outer ply in the pouch seal area is acceptable and shall not be classified as a minor defect unless it extends to within 1/16 inch of the food product edge of the seal. All other minor outer ply delamination in the pouch seal area or isolated spots of delamination in the body of the pouch that do not propagate when flexed as described above shall be classified as minor.

2/ Scale or dust on the outside of pouches caused by retort water may be removed by washing. The following examples shall not be scored as defects for unclean:

- a. Water spots.
- b. Two or less specks of dried product each of which measure 1/8 inch by 1/8 inch or equivalent area, or less.
- c. Any foreign matter which presents no health hazard or no potential pouch damage and which readily falls off when pouch is lifted and shaken lightly.
- d. Very thin film of grease, oil, or product residue which is discernible to touch, but not readily discernible by visual examinations.
- e. Thin strips or drops of adhesive.

3/ If doubt exists as to whether or not the sealing equipment leaves an impression or design on the heat seal surfaces that could conceal or impair visual detection of seal defects, samples shall be furnished to the contracting officer for a determination as to acceptability.

MIL-PRF-44073F

4.2.1 Examination of pouch and carton assembly. The pouch and carton assembly shall be examined for compliance with the requirements specified in 3.1.6 and 3.1.7. Defects and defect classifications are listed in table III.

TABLE III. Pouch and carton assembly defects

Category			Defect
<u>Critical</u>	<u>Major</u>	<u>Minor</u>	
1			Tear, hole, or puncture through carton or open carton causing a hole in the pouch or obviously wet or stained carton due to leaking pouch.
	101		Tear or hole in carton exposing pouch to potential damage.
	102		Outer flaps of carton not closed.
	103		Carton not clean.
	104		Pouch body not in a flat, fully extended position in carton.
	105		Carton labeling is missing, incorrect or illegible.
	106		Bond strength in carton closure is not greater than fiber strength of paperboard of carton.
		201	Tear or hole in carton not exposing pouch to potential damage.
		202	Color of carton not as specified.
		203	Outer flaps of carton not closed to within 1/2 inch of either end.

4.3 Tests.

4.3.1 Oxygen transmission rate. The oxygen transmission rate of the material shall be determined in accordance with ASTM D 3985.

4.3.2 Water vapor transmission rate. The water vapor transmission rate of the material shall be

MIL-PRF-44073F

determined in accordance with ASTM F 372.

4.3.3 Thermal processing. Testing for thermal processing of the material shall be as follows: Material shall be formed into 5 or 8 ounce size pouches in accordance with figure 1. Pouches shall be filled with five or eight ounces of water, sealed and exposed to the same thermal processing conditions as required for filled and sealed pouches by the food product document. Following thermal processing, pouches shall be examined visually. Any pouch material defect as a result of thermal processing shall be considered a test failure.

4.3.4 Environmental conditions.

4.3.4.1 Low temperature. Fill the pouches with water, seal and thermal process as in 3.1.5. After thermal processing, unit pack in paperboard cartons. Condition the unit packs in an atmosphere uniformly maintained at $28^{\circ}\text{F} \pm 2^{\circ}\text{F}$ for a period of 48 hours. During exposure, position the unit packs to allow free circulation of air around each pack. Conduct a pouch abuse test while still in the frozen state using the test apparatus shown in figure 2. For eight ounce unit packs, the drop height shall be 40 inches; for five ounce unit packs, the drop height shall be 64 inches. Drop each unit pack twice, once on each end. Recondition tested unit packs to ambient temperature for at least 24 hours, remove pouches from cartons and examine visually. Any pouch leakage shall be considered a test failure.

4.3.4.2 High temperature. Fill the pouches with water, seal and thermal process as in 3.1.5. After thermal processing, unit pack in paperboard cartons. Condition the unit packs in an atmosphere uniformly maintained at $160^{\circ}\text{F} \pm 2^{\circ}\text{F}$ for a period of 48 hours. During exposure, position the unit packs to allow free circulation of air around each pack. Conduct a pouch abuse test using the test apparatus shown in figure 2. For eight ounce unit packs, the drop height shall be 40 inches; for five ounce unit packs, the drop height shall be 64 inches. Drop each unit pack twice, once on each end. Recondition tested unit packs to ambient temperature for at least 24 hours, remove pouches from cartons and examine visually. Any pouch leakage shall be considered a test failure.

4.3.5 Camouflage. External visible color of the outside surfaces of the pouch material before and after thermal processing shall conform to the range of the government approved and standardized color swatches. Standardized swatch samples have been provided to and are on file with each contractor, each material supplier, USDA, Natick, and DSCP. Visibly match the outside surface of the pouch material to the range of colors of the standardized color swatch samples.

4.3.6 Residual gas volume test. The samples for test shall be opened under $75^{\circ}\text{F} \pm 5^{\circ}\text{F}$ water and the gases shall be collected by water displacement in a graduated cylinder or other calibrated tube. The volume of the gases shall be reported to the nearest 0.1 cubic centimeter. Any residual gas volume exceeding 20 cubic centimeters in pouches filled with Class 1, Class 2, or Class 3 products shall be considered a test failure. Any residual gas volume exceeding 10 cubic centimeters in pouches filled with Class 4 products shall be considered a test failure.

4.3.7 Internal pressure test. Internal pressure resistance shall be determined by pressurizing the

MIL-PRF-44073F

pouches while they are restrained between two rigid plates spaced 1/2 inch \pm 1/16 inch apart. If a three-seal tester (one that pressurizes the pouch through an open end) is used, the closure seal shall be cut off for testing the side and bottom seals of the pouch; for testing of the closure seal, the bottom seal shall be cut off. The pouches shall be emptied prior to testing. If a four-seal tester (designed to pressurize filled pouches by use of a hypodermic needle through the pouch wall) is used, all four seals can be tested simultaneously. Pressure shall be applied at the approximate uniform rate of 1 psig per second until 20 psig pressure is reached. The 20 psig pressure shall be held constant for 30 seconds and then released. The pouches shall then be examined for separation or yield of the heat seals. Any rupture of the pouch or evidence of seal separation greater than 1/16 inch in the pouch manufacturer's seal shall be considered a test failure. Any seal separation that reduces the effective closure seal width to less than 1/16 inch (see table II) shall be considered a test failure.

4.3.8 Commercial sterility test. Incubate filled, sealed and thermally processed pouches as follows:

- a. Classes 1, 2, and 3: Incubate at $95^{\circ}\text{F} \pm 5^{\circ}\text{F}$ for 10 days, unless otherwise specified by the inspection agency.
- b. Class 4: Incubate at $80^{\circ}\text{F} \pm 5^{\circ}\text{F}$ for 10 days.

Any evidence of swelling or microbial activity following incubation shall be considered a test failure.

4.3.9 Carton closure bond strength. Compliance with required bond strength in carton closure shall be verified by visually examining flaps for evidence of fiber tear after opening. Absence of fiber tear shall be considered a test failure.

5. PACKAGING

This section is not applicable to this specification.

6. NOTES

(This section contains information of a general or explanatory nature that may be helpful, but is not mandatory.)

6.1 Acquisition requirements. Acquisition documents must specify the following:

- a. Title, number, and date of the specification.
- b. Class required (see 1.2).
- c. Issue of DoDISS to be cited in the solicitation, and if required, the specific issue of individual documents referenced (see 2.3).

MIL-PRF-44073F

d. Pouch sizes for class 1, 2, 3, and 4 (see 3.1.2 and figure 1).

6.2 Pouch material. The U.S. Army Soldier Biological and Chemical Command (SBCCOM), Natick Soldier Center (NSC) has found that for preformed pouches, a material structure consisting of, from inside to outside, 0.003 to 0.004 inch thick polyolefin, 0.00035 to 0.0007 inch thick aluminum foil, 0.0006 inch thick biaxially oriented polyamide-type 6, and 0.0005 inch thick polyester meets the performance criteria of this specification. Alternatively, the aluminum foil layer and the biaxially oriented polyamide layer may be in either order. For the formed, tray-shaped body of a horizontal form-fill-seal (HFFS) pouch, it has been found that a material structure consisting of, from inside to outside, 0.003 to 0.004 inch thick polyolefin, 0.0006 inch thick biaxially oriented polyamide-type 6, 0.0015 to 0.00175 inch thick aluminum foil and 0.0010-0.0014 inch thick oriented polypropylene meets the performance criteria of this specification. For the lidding material for the HFFS pouch, it has been found that a material structure consisting of, from inside to outside 0.003 to 0.004 inch thick polyolefin, 0.00035 to 0.0007 inch thick aluminum foil and 0.0005 to 0.00075 inch thick polyester meets the performance criteria of this specification. The above values and ranges expressed for the thickness of thin gauge plastic films and aluminum foil are nominal values. A plus or minus 20% tolerance is typical for thin gauge plastic film thickness measurements and a plus or minus 10% tolerance is typical for aluminum foil thickness measurements.

6.3 Carton design and material. The SSCOM (NRDEC) has found that a carton design and material conforming to variety I, style I, type A, class a or style XIV, group I or II of PPP-B-566, Boxes, Folding, Paperboard, except that the carton may be made of 16-point bending chips, kraft lined chips or unbleached solid sulfate paperboard or of 17-point low density kraft paperboard having a minimum basis weight for the bending chips and the kraft lined chipboard of 60 pounds per 1000 square feet, a minimum basis weight for the unbleached solid sulfate board of 55 pounds per 1000 square feet or a minimum basis weight for the low density kraft paperboard of 48 pounds per square feet meets the performance criteria of this specification. The use of materials composed of the highest percentage of recovered materials practicable is encouraged by the Resource Conservation and Recovery Act of 1976.

6.4 Technical information. Specific technical inquiries may be addressed to the Commander, U.S. Army Soldier Systems Biological Chemical Command, Natick Soldier Center, ATTN: AMSSB-RCF-F(N), 15 Kansas Street, Natick, MA 01760-5018.

6.5 Subject term (key word) listing.

Meal, Ready-to-Eat

MRE

Operational rations

6.6 Changes from previous issue. Marginal notations are not used in this revision to identify changes with respect to the previous issue due to the extent of the changes.

MIL-PRF-44073F

Custodians:

Army - GL
Navy - SA
Air Force - 35

Preparing activity:

Army - GL

(Project 89GP-A003)

Review activities:

Army - MD, QM
Navy - MC
DLA - SS

MIL-PRF-44073F

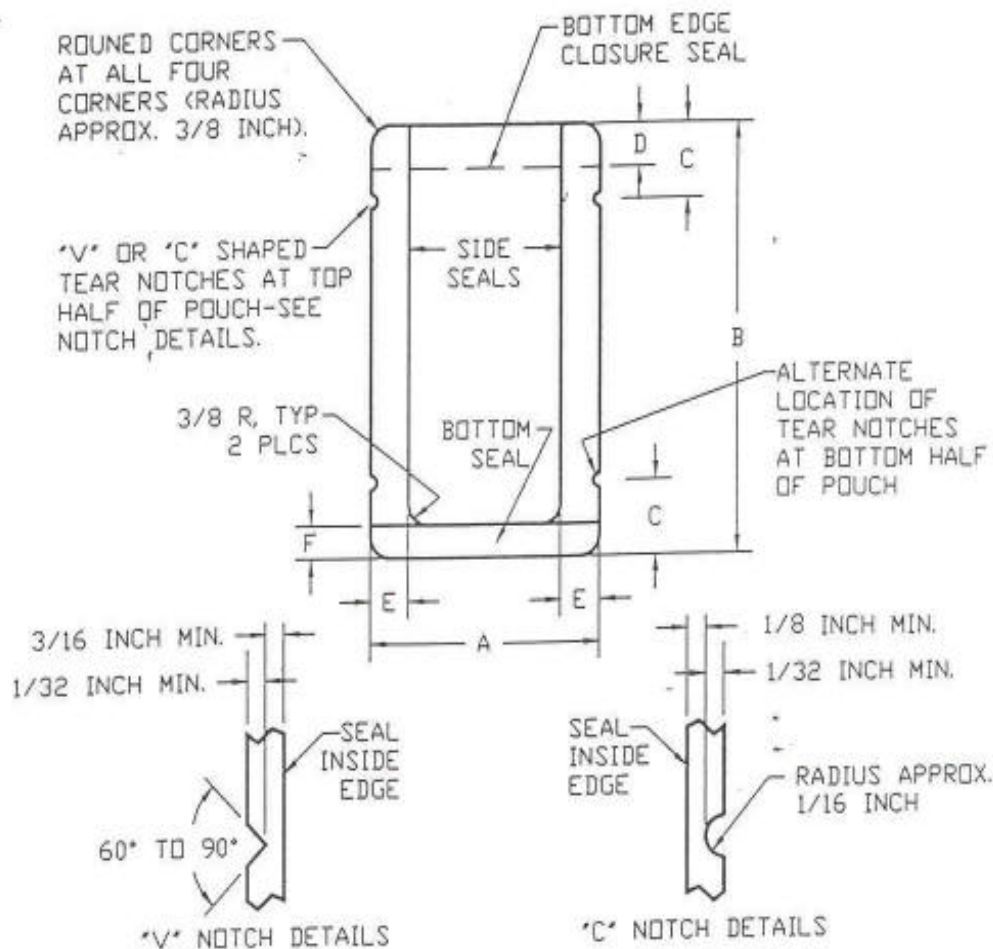

POUCH SIZES	DIMENSIONS IN INCHES					
	A	B	C	D	E	F
5 OUNCE SIZE 1/	4 3/4 (± 1/16)	6 1/16 TO 6 1/4	1 (± 1/16)	3/4 MAX.	7/32 MIN.	1/8 MIN.
		6 1/4 TO 7 3/8	1 1/2 ± 1/16	1 MAX		
PRIMARY 1/8 8 OUNCE SIZE	4 3/4 (± 1/16)	8 1/8 (+ 1/8 - 1/16)	1 1/2 (± 1/16)	1 MAX	7/32 MIN.	1/8 MIN.
ALTERNATE 1/8 8 OUNCE SIZE	5 1/4 (± 1/16)	7 1/4 (+ 1/8 - 1/16)	1 1/2 (± 1/16)	1 MAX	7/32 MIN.	1/8 MIN.

NOTES: 1. ALL FIVE OUNCE SIZE POUCHES HAVING A "B" DIMENSION OF MORE THAN 6 1/4 INCHES AND ALTERNATE EIGHT OUNCE SIZE POUCHES SHALL HAVE A SECOND SET OF NOTCHES LOCATED NOT LESS THAN 2 5/8 OR MORE THAN 3 1/16 INCHES FROM THE END OF THE POUCH USED TO LOCATE THE SET OF NOTCHES ILLUSTRATED ABOVE. ALL PRIMARY EIGHT OUNCE SIZE POUCHES SHALL HAVE A SECOND SET OF NOTCHES LOCATED 3 ± 1/16 INCHES FROM THE END OF THE POUCH USED TO LOCATE THE SET NOTCHES ILLUSTRATED ABOVE.

FIGURE 1

MIL-PRF-44073F

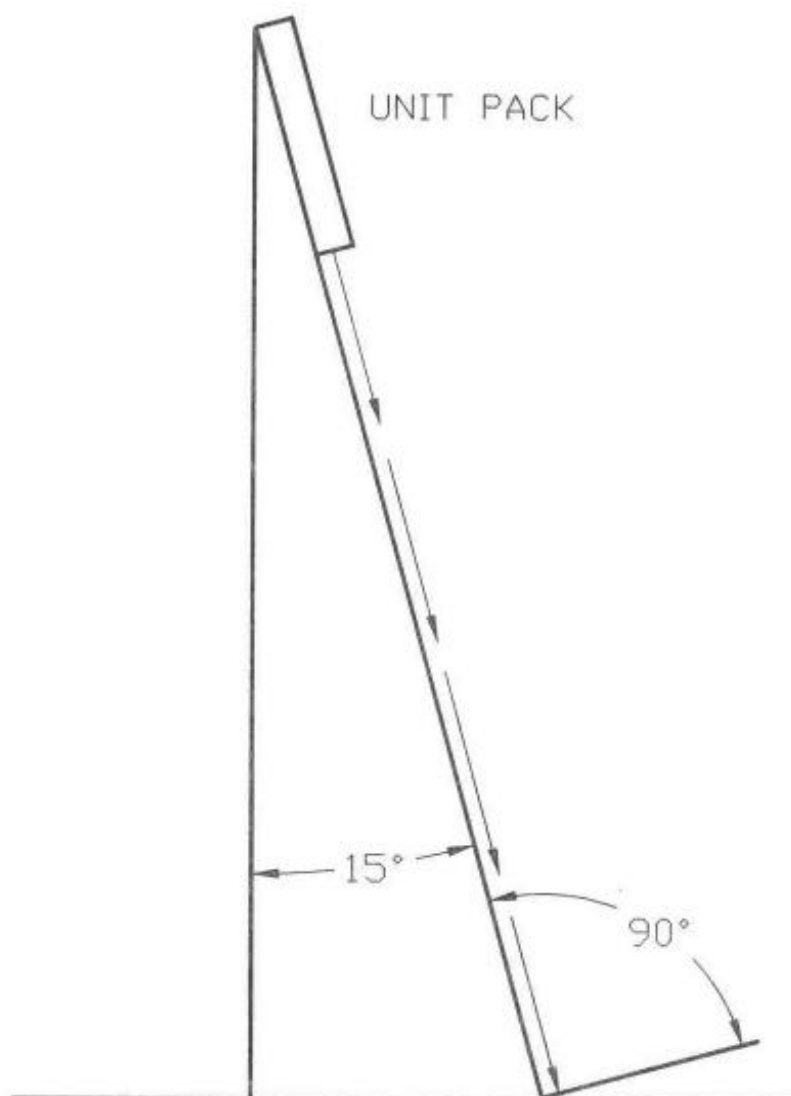

FIGURE 2
POUCH ABUSE TEST APPARATUS

STANDARDIZATION DOCUMENT IMPROVEMENT PROPOSAL

INSTRUCTIONS

1. The preparing activity must complete blocks 1, 2, 3, and 8. In block 1, both the document number and revision letter should be given.
2. The submitter of this form must complete blocks 4, 5, 6, and 7, and send to preparing activity.
3. The preparing activity must provide a reply within 30 days from receipt of the form.

NOTE: This form may not be used to request copies of documents, nor to request waivers, or clarification of requirements on current contracts. Comments submitted on this form do not constitute or imply authorization to waive any portion of the referenced document(s) or to amend contractual requirements.

I RECOMMEND A CHANGE:	1. DOCUMENT NUMBER MIL-PRF-44073F	2. DOCUMENT DATE (YYYYMMDD) 2001 09 04
------------------------------	---	--

3. DOCUMENT TITLE	PACKAGING OF FOOD IN FLEXIBLE POUCHES
--------------------------	--

4. NATURE OF CHANGE <i>(Identify paragraph number and include proposed rewrite, if possible. Attach extra sheets as needed.)</i>	
---	--

5. REASON FOR RECOMMENDATION	
-------------------------------------	--

6. SUBMITTER		
a. NAME <i>(Last, First, Middle Initial)</i>	b. ORGANIZATION	
c. ADDRESS <i>(Include ZIP code)</i>	d. TELEPHONE <i>(Include Area Code)</i> (1) Commercial (2) DSN <i>(If applicable)</i>	7. DATE SUBMITTED (YYYYMMDD)

8. PREPARING ACTIVITY	
a. NAME US Army Soldier & Biological Chemical Command Natick Soldier Center	b. TELEPHONE <i>(Include Area Code)</i> (1) Commercial 508-233-5907 (2) DSN 256-5907
c. ADDRESS <i>(Include ZIP code)</i> US Army Soldier & Biological Chemical Command Natick Soldier Center Attn: AMSSB-RCF-FN 15 Kansas Street Natick, MA 01760-5018	IF YOU DO NOT RECEIVE A REPLY WITHIN 45 DAYS, CONTACT: Defense Standardization Program Office (DLSC-LM) 8725 John J. Kingman Road, Suite 2533 Fort Belvoir, Virginia 22060-6221 Telephone (703) 767-6888 DSN 427-6888