

INCH-POUND

MIL-PRF-39012/16H  
 16 November 2006  
 SUPERSEDING  
 MIL-PRF-39012/16G  
 26 September 1994

## PERFORMANCE SPECIFICATION SHEET

CONNECTORS, PLUGS, ELECTRICAL, COAXIAL RADIO FREQUENCY,  
 (SERIES BNC (CABLED), PIN CONTACT, CLASS 2)

This specification is approved for use by all Departments  
 and Agencies of the Department of Defense.

The requirements for acquiring the product described herein shall  
 consist of this specification sheet and MIL-PRF-39012.

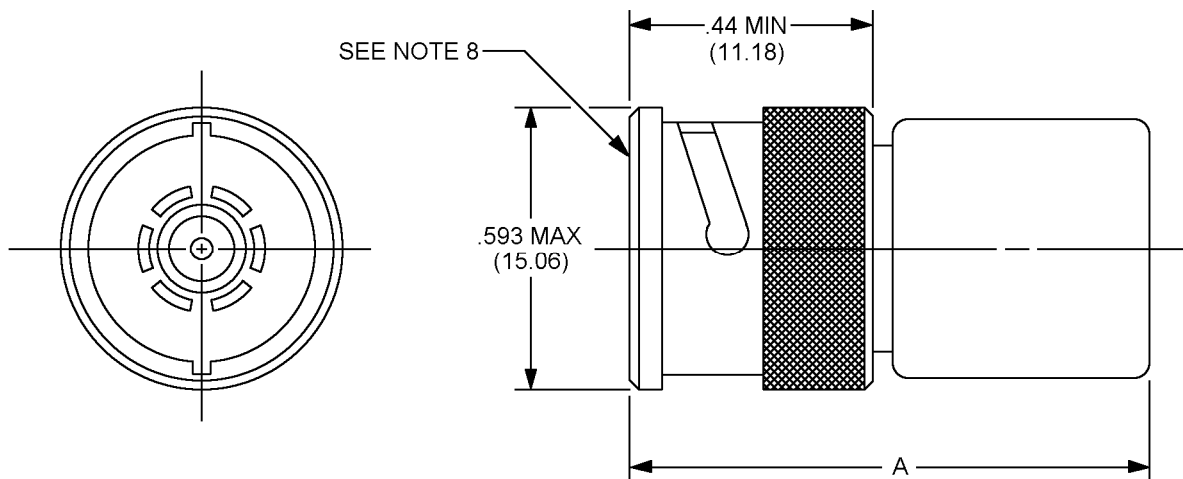

## NOTES:

1. Dimensions are in inches.
2. Metric equivalents are given for information only.
3. For dimension A, see tables I and III.
4. Dimension .593 inch (15.06 mm) is the largest overall diameter of the connector.
5. Wrench flats are to accommodate standard wrench opening in accordance with FED-STD-H28, appendix 10.
6. All undimensioned pictorial representations are for reference purposes only.
7. Dimension A defines the maximum length of the connector when assembled to the appropriate cable.
8. Series BNC, pin contact interface in accordance with MIL-STD-348.

FIGURE 1. General configuration.

## MIL-PRF-39012/16H

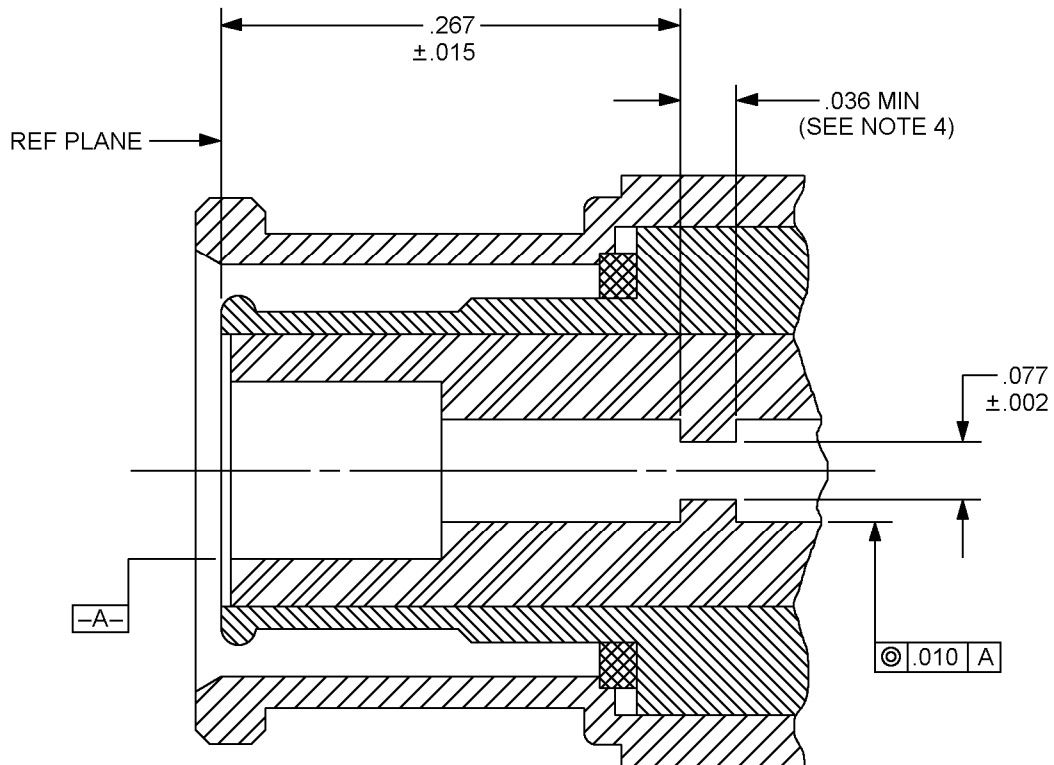

inches	mm
.002	0.05
.010	0.20
.015	0.38
.036	0.91
.077	1.96
.267	6.78

## NOTES:

1. Dimensions are in inches.
2. Metric equivalents are given for information only.
3. In the mated condition, the longitudinal force of the spring of the coupling mechanism shall exceed the pressure exerted by the sealing gasket by an amount necessary to insure butting of the outer contacts at the reference plane.
4. Chamfer is optional.

FIGURE 2. Category D captivation detail.

## MIL-PRF-39012/16H

TABLE I. Dash numbers, cross reference, and dimensions.

Part or Identifying Number (PIN) <u>1/</u> M39012/16-	Applicable cable <u>2/</u> M17/	Dimensions	Inches (millimeters) maximum #
Category A – Field serviceable (no special tools required) <u>3/</u>			
X101 (superseding –X111 <u>4/</u> )	Cable group VI  60-RG142 <u>5/</u> 128-RG400 <u>6/</u>	A	1.250 (31.75)
X102 (Superseding –0118 <u>4/</u> )	Cable group VII  110-RG302 <u>5/ 6/ 7/</u>		
X103	Cable group IV  54-RG122 <u>6/</u>		
X220	Cable group II  113-RG316 <u>5/ 6/</u>		
X225 Cable group X	Cable group X  127-RG393 <u>5/ 6/</u>	A	1.739 (44.17)
Category C – field replaceable (MIL-DTL-22520 crimp tool) See note next to applicable cable for crimp die <u>3/ 8/</u>			
X013	Cable group VIA <u>9/</u>  111-RG305 <u>5/ 6/</u>	A	1.500 (38.10)
X014	Cable group VIB <u>9/</u>  60-RG142 <u>5/</u> 128-RG400 <u>6/</u>		
X015 (Superseding –X220 <u>4/</u> )	Cable group VIIA <u>10/</u>  110-RG302 <u>5/ 6/ 7/</u>		

See notes at end of table.

## MIL-PRF-39012/16H

TABLE I. Dash numbers, cross reference, and dimensions – Continued.

PIN <u>1/</u> M39012/16-	Applicable cable <u>2/</u> M17/	Dimensions	Inches (millimeters) maximum #
Category C – field replaceable (MIL-DTL-22520 crimp tool) See note next to applicable cable for crimp die <u>3/ 8/</u>			
X016	Cable group IV <u>11/</u> 54-RG122 <u>6/</u>	A	1.500 (38.10)
X017	Cable group VIIB <u>10/</u> 90-RG71 <u>6/ 7/</u>		
X222	Cable group IIA <u>12/</u> 113-RG316 <u>5/ 6/ 12/</u>		
Category D – Field replaceable – Defined piece part <u>3/ 8/ 13/ 14/</u>			
X501	Cable group IV 54-RG122 <u>6/</u>	A	1.500 (38.10)
X502	Cable group V 95-RG180 <u>5/ 6/ 7/</u>		
X503 Cable group VIB	Cable group VIB 60-RG142 <u>5/</u> 128-RG400 <u>6/</u>		
X504	Cable group VIA 111-RG303 <u>5/ 6/</u>		

1/ For cross-reference of dash number to superseded PIN or designation, see table IV.

2/ The latest version of each cable shall be applicable.

3/ These connectors have captivated center contacts.

## MIL-PRF-39012/16H

TABLE I. Dash numbers, cross reference, and dimensions – Continued.

- 4/ The superseded PIN is **NOT** acceptable for Government use.
- 5/ Cable to be used for the +200°C temperature cycling tests. This cable can be used for tests with the approval of the Qualifying Activity.
- 6/ Cable to be used when performing test requiring cable except as in 5/ and 7/.
- 7/ These are not 50-ohm cables; therefore, when attached to the specified connectors, VSWR, RF, leakage and insertion loss are not applicable.
- 8/ These connectors are assembled using the applicable crimp tool, to the specified cables stripped as shown on figure 4.
- 9/ M22520/5-19 closure B or MS22520/5-05 closure A.  
M22520/5-11 closure A.  
M22520/5-57 closure A.
- 10/ M22520/5-19 closure A or M22520/5-07 closure A.  
M22520/5-13 closure A.  
M22520/5-59 closure A.
- 11/ M22520/5-41 closure B or M22520/5-05 closure B.  
M22520/5-09 closure A.
- 12/ M22520/5-35 closure B or 22520/5-03 closure A.
- 13/ Complete connector assembly shall consist of a body, center contact, ferrule and assembly instructions.
- 14/ Not to be used in Army equipment.
- # Dimensions are in inches. Metric equivalents are given for information only.
- X Denotes connector body plating material option. The only plating options allowable are Silver or Nickel over brass in accordance with MIL-PRF-39012. Only connectors of the same materials shall be mated to avoid dissimilar metal problems. **CAUTION: A NICKEL PLATED BODY IS NOT FOR USE IN APPLICATIONS WHERE PASSIVE INTERMODULATION GENERATION (PIM) MAY BE A CONCERN** (<http://amphenolrf.com/simple/PIM%20Paper.pdf>). Silver is the preferred plating.

MIL-PRF-39012/16H

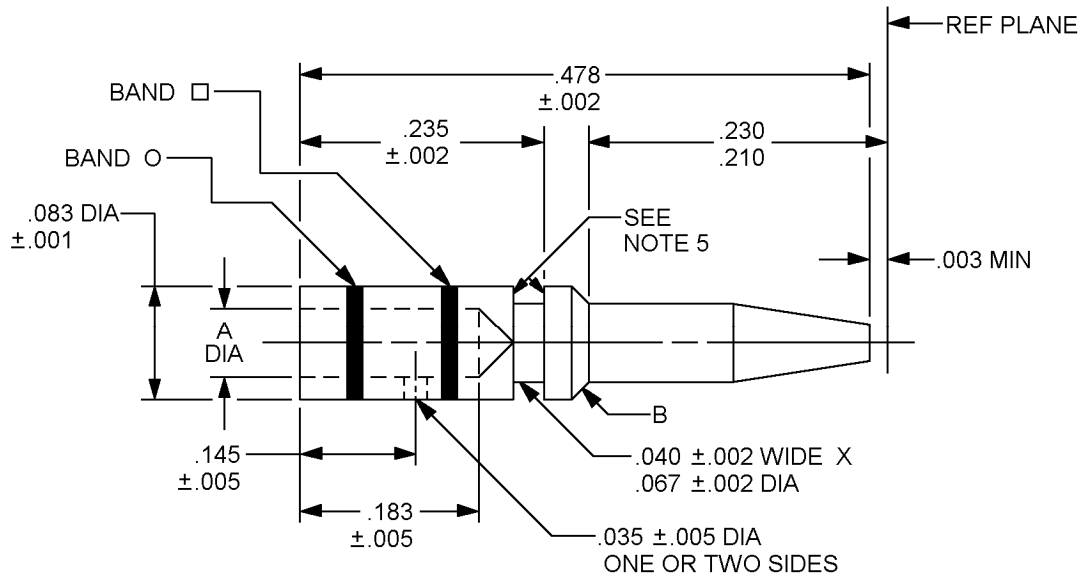

CENTER CONTACT

Inches	mm	Inches	mm	Inches	mm	Inches	mm
.001	0.03	.033	0.84	.145	3.68	.220	5.59
.002	0.05	.035	0.89	.175	4.45	.230	5.84
.003	0.08	.040	1.02	.183	4.65	.235	5.97
.005	0.13	.043	1.09	.206	5.23	.245	6.22
.015	0.38	.067	1.70	.210	5.33	.250	6.35
.017	0.43	.083	2.11	.212	5.38	.478	12.14
						.500	12.70

Dash no.	Contact no. <u>1/</u>	A +0.001 -0.002	B	Basic crimp tool <u>2/</u>	Crimp die or positioner	Crimp tensile pounds min. (N)	Color band □	Color band ○
X501	16 – 12	0.033	.005 +.003 -.000 x 45°	M22520/1-01	M22520/1-12	10 lbs (44.48)	Orn	Yellow
X502	16 – 11	0.017	.005 +.003 .- 000 x 30°			6 lbs (26.69)	Blue	
X503 X504	16 – 10	0.043	.005 +.003 -.000 x 45°	M22520/1-01	M22520/1-12	20 lbs (88.96)	Red	

1/ Contact numbers and ferrule numbers are for identification only.

2/ Class 2 tool may be used by OEM (see MIL-DTL-22520).

FIGURE 3. Contact and ferrule dimensions for category D only.

## MIL-PRF-39012/16H

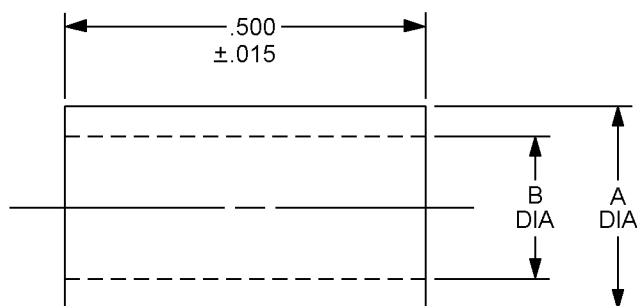
CRIMP FERRULE

Dash number	Ferrule number <u>1/</u>	A ± 0.003	B ± 0.003	Basic crimp tool <u>2/</u>	Crimp die or positioner M22520/5
X501 X502	16-50	0.212	0.175	M22520/5-01	-9 Closure A -5 or -41 Closure B
X503	16-51	0.250	0.220		-5, -11, -57 Closure A or - 19 Closure B
X504	16-52	0.245	0.206		

1/ Contact numbers and ferrule numbers are for identification only.

2/ Class 2 tool may be used by OEM (see MIL-DTL-22520).

## NOTES:

- Dimensions are in inches.
- Metric equivalents are given for information only.
- Crimp tensile test shall be in accordance with SAE-AS39029.
- Copyright notice: ALL information disclosed in these specification sheets which is or may be copyright is reproduced herein with the express permission of the copyright owner.
- .003 inch maximum break.
- Color bands shall be positioned so that no coloring material enters the inspection hole.

FIGURE 3. Contact and ferrule dimensions for category D only – Continued.

MIL-PRF-39012/16H

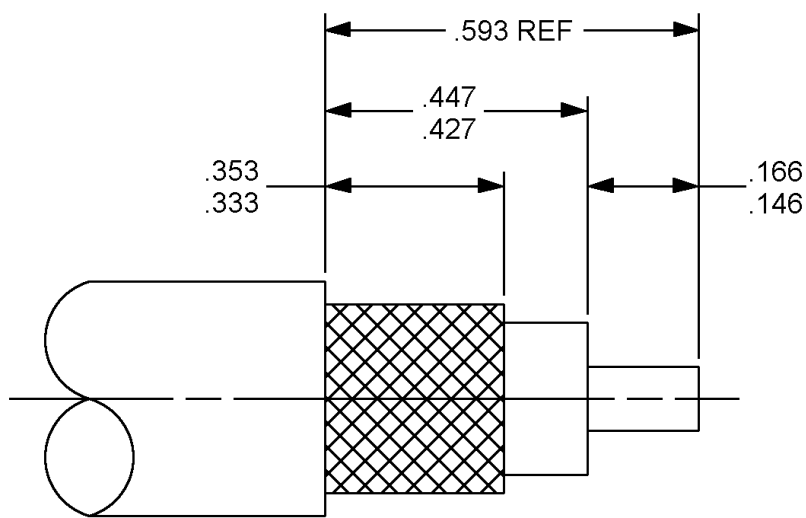

Inches	mm
.146	3.71
.166	4.22
.333	8.46
.353	8.97
.427	10.85
.447	11.35
.593	15.06

## NOTES:

1. Dimensions are in inches.
2. Metric equivalents are given for information only.

FIGURE 4. Cable stripping dimensions for field replaceable connectors.



MIL-PRF-39012/16H

ENGINEERING DATA:

Nominal Impedance: 50 ohms.

Frequency range: 0 to 4 GHz.

Voltage rating:

500 volts rms, maximum working voltage at sea level.

125 volts rms, maximum at 70,000 feet (4.437 kPa).

Temperature rating; -65°C to +165°C.

REQUIREMENTS:

Design and configurations: See figures 1, 2, 3, and 4.

Force to engage and disengage:

Longitudinal force: 3 pounds (13.34 N), maximum.

Torque: 2.5 inch-pounds (.28 Nm), maximum.

Coupling proof torque: Not applicable.

Inspection conditions: Coupling torque not applicable.

Mating characteristics;

In accordance with MIL-STD-348 and figure 2.

Outer contact:

Test ring ID: .319 inch (8.10 mm) maximum, 16 microinch (0.406  $\mu$ m) finish.

Insertion force: 5 pounds (22.24 N), maximum when inserted a minimum of .093 inch (2.36 mm).

Contacts with slotted members: Shall contact a .324 inch (8.23 mm), minimum diameter ring within .031 inch (0.79 mm) of their tip ends.

Hermetic seal: Not applicable.

Leakage (pressurized connectors): Not applicable.

Insulation resistance: Method 302 of MIL-STD-202, test condition B, 5,000 megohms, minimum.

Center contact retention: 6 pounds (26.69 N) minimum axial force. Applicable to captivated-center-contact connectors only.

Corrosion (salt spray): Method 101 of MIL-STD-202, test condition B.

## MIL-PRF-39012/16H

Voltage standing wave ratio (VSWR): From .5 to 4 GHz, or approximately 80 percent of upper cutoff frequency of the cable, whichever is lower; 1.30, maximum.

Swept frequency VSWR test setup:

Item 6: VSWR shall be less than  $1.015 + .005 F$  (F in GHz).

Item 16: VSWR shall be less than  $1.015 + .005 F$  (F in GHz).

Second step of VSWR checkout procedure: VSWR shall be less than  $1.045 + .019 F$  (F in GHz).

Group B inspection; VSWR shall be less than  $1.1 + .01 F$  (F in GHz).

Qualification and group C inspection: VSWR shall not exceed 1.15.

Connector durability: 500 cycles minimum, at 12 cycles per minute, maximum. The connector shall meet the mating characteristics and force to engage and disengage requirements.

Initial: 5 pounds (22.24 N), maximum.

Final: 5 pounds (22.24 N) maximum; 1 pound (4.45 N), minimum.

Contact resistance: In milliohms, maximum:

	<u>Initial</u>	<u>After environment</u>
Center contact	1.5	2.0
Outer contact (silver)	.2	Not applicable
Outer contact (nickel)	.4	Not applicable
Braid to body	.1	Not applicable

Dielectric withstanding voltage: Method 301 of MIL-STD-202, 1,500 volts rms, minimum at sea level.

Vibration, high frequency: Method 204 of MIL-STD-202, test condition B. No discontinuity permitted.

Shock: Method 213 of MIL-STD-202, test condition G.

Thermal shock: Method 107 of MIL-STD-202, test condition B, except test high temperature shall be +85°C. High temperature shall be at +200°C for connectors using +200°C cables (see tables I and III).

Moisture resistance: Method 106 of MIL-STD-202. No measurements at high humidity. Insulation resistance shall be at least 200 megohms within 5 minutes after removal from humidity.

Corona Level:

Voltage: 375 volts rms, minimum.

Altitude: 70,000 feet (4.437 kPa).

MIL-PRF-39012/16H

RF high potential withstanding voltage:

Voltage and frequency: 1,000 volts rms at a frequency from 5 to 7.5 MHz.

Leakage current: Not applicable.

Cable retention force:

Noncrimp assemblies: 40 pounds (177.93 N), minimum.

Crimp assemblies:

10 pounds (44.48 N), minimum for cables .155 - .189 inch (3.94 mm – 4.80 mm) OD.

20 pounds (88.96 N), minimum for cables .190 - .229 inch (4.83 mm – 5.82 mm) OD.

30 pounds (133.45 N), minimum for cables .230 - .249 inch (5.84 mm – 6.32 mm) OD.

40 pounds (177.93 N), minimum for cables .250 inch (6.35 mm) OD and larger.

Coupling mechanism retention force: 100 pounds (444.82 N), minimum.

RF Leakage: -55 dB minimum, tested at a frequency between 2 and 3 GHz.

Insertion loss:

.2 dB maximum tested at 3 GHz.

PIN: M39012/16 (dash number from table I or "B" number from table III).

Group qualification: See table II.

## MIL-PRF-39012/16H

TABLE II. Group qualification. <sup>1/</sup>

Group	Submission and qualification of <sup>2/</sup> any of the following connectors	Qualifies the following connectors
I	M39012/16 -X101 -X103 -X111 -X118 -X220 -X225	M39012/16 -X101 -X102 -X103 -X111 -X118 -X220 -X225
II	-X102	-X102
III	B0004 B0005 B0006 B0007 B0009 B0019	B0004 B0005 B0006 B0007 B0008 B0009 B0012 B0019
IV	B0008 B0012	B0008 B0012
V	-X013 -X014 -X016 -X020 -X222	-X013 -X014 -X015 -X016 -X017 -X020 -X222
VI	-X015 -X017	-X015 -X017
VII	-X501 -X503 -X504	-X501 -X502 -X503 -X504
VIII	-X502	-X502

<sup>1/</sup> If a connector manufacturer produces a connector which meets all the requirements for two or more connector PIN's (within the same series), the manufacturer may receive qualification approval for two or more connector PIN's qualifying the one connector. It is not necessary that such connectors be in the same group. Each connector, however, must be marked with its own appropriate PIN. For group qualification, the connectors must be of similar design and be of the same materials and plating.

<sup>2/</sup> For qualification retention, where more than one part is listed in a group in this column, data may be supplied on any of those parts in order to retain qualification for those parts in the corresponding right hand column. The part does not necessarily have to be the part initially qualified.

## MIL-PRF-39012/16H

TABLE III. Category B – Non-field replaceable (special tools may be required).

Not for Air Force, Army, or Navy use. For OEM use only.

Dash number <u>1/</u> <u>2/</u> <u>3/</u>	Applicable cable M17/ #	Dimensions	Inches (millimeters) maximum #
M39012/16B0004	28-RG058*	A	1.500 (38.10)
M39012/16B0005	84-RG223*		
M39012/16B0006	111-RG303*		
M39012/16B0007	60-RG142* @		
M39012/16B0008	29-RG59* ^ 30-RG062 ^ 97-RG210 ^		
M39012/16B0009	54-RG122*		
M39012/16B0012	90-RG71* ^		
M39012/16B0019	110-RG302^ * @		

1/ For cross-reference of dash number to superseded PIN or type designation, see table IV.

2/ For maintenance replacements for category B, see table V.

3/ Inactive for new design.

# The latest version of each cable shall be applicable.

\* Cable to be used when performing tests requiring cable except as in notes @ and ^.

@ Cable to be used for the +200°C temperature cycling tests. This cable can be used for tests with the approval of the Qualifying Activity.

^ These are not 50 ohm cables; therefore, when attached to the specified connectors, VSWR, RF leakage, and Insertion loss are not applicable.

# Dimensions are in inches. Metric equivalents are given for information only.

## MIL-PRF-39012/16H

TABLE IV. Cross-reference of PIN.

Preferred PIN M39012/16	Substitute for PIN or type designation <u>1/</u> <u>2/</u>
-0101	UG-88/U, M39012/16-0001
-0102	UG-260/U, M39012/16-0002, M39012/16-0018, m39012/16-0118
-0103	UB-1033/U, M39012/16-0003
B0004	M23329/3-01, M39012/16-0004
B0005	M23329/3-02, M39012/16-0005
B0006	M23329/3-03, M39012/16-0006
B0007	M23229/3-04, M39012/16-0007
B0008	M23329/3-05, M39012/16-0008
B0009	M23329/3-06, M39012/16-0009
-0111	M39012/16-0011
B0012	M39012/16-0012
-0013	
-0014	
-0015	
-0016	
-0017	
B0019	M39012/16-0019
-0020	
-0501	
-0502	
-0503	
-0504	
-0225	UG-959/U

1/ The superseded PIN or the type designation is for cross-reference only. Where a superseded PIN or type designation is not given, none was assigned or will be assigned. The PIN M39012/16-XXXX shall be used in all cases for marking and identifying the connector.

2/ The basic type designation includes all letter versions of the specified number, e.g. UG-18/U includes UG-18 A/U, UG-18 B/U, etc.

TABLE V. Maintenance replacements for category B.

Category B number* Inactive for new design	Category C dash number	Category A dash number	Category D dash number
B0004	0013	0101	0504
B0005	0014	0101	---
B0006	0013	0111	---
B0007	0014	0101	0503
B0008	0015	0102	---
B0009	0016	0103	0501
B0012	0017	0102	---
B0019	0020	0118	---

\* Category B connectors are for original installation only. They will not be stocked or acquired by the Government.

MIL-PRF-39012/16H

Changes from previous issue. Marginal notations are not used in this revision to identify changes with respect to the previous issue due to the extent of the changes.

Referenced documents. In addition to MIL-PRF-39012, this document references the following:

FED-STD-H28  
MIL-STD-202  
MIL-STD-348  
MIL-DTL-22520  
SAE-AS39029

CONCLUDING MATERIAL

Custodians:

Army - CR  
Navy - EC  
Air Force – 11  
DLA - CC  
NASA - NA

Preparing activity:

DLA-CC

(Project 5935-2005-020)

Review activities:

Army: - AR, AT, EA, MI  
Navy - AS, MC, OS, SH  
Air Force - 19, 99

NOTE: The activities listed above were interested in this document as of the date of this document. Since organizations and responsibilities can change, you should verify the currency of the information above using the ASSIST Online database at <http://assist.daps.dla.mil>.