

METRIC

MIL-PRF-32564

07 October 2016

PERFORMANCE SPECIFICATION FOR
U.S. ARMY GROUND VEHICLE
ENERGY ATTENUATION (EA) STEERING SUBSYSTEMS



Comments, suggestions, or questions on this document should be addressed to U.S. Army RDECOM, Tank Automotive Research Development and Engineering Center, ATTN: RDTA-SIE-ES-PLDP-PLDE-DIS, MS #268, 6501 E. 11 Mile Road, Warren, MI 48397-5000 or sent by email to usarmy.detroit.rdecom.mbx.tardec-standardization@mail.mil. Since contact information can change, you may want to verify the currency of this address information using the ASSIST Online database at <https://assist.dla.mil>.

AMSC N/A

FSC 2530

DISTRIBUTION STATEMENT A. Approved for public release; distribution is unlimited.

MIL-PRF-32564

1. SCOPE

1.1 Scope. This performance specification describes performance and verification requirements for Army Ground Vehicle steering subsystems with steering wheels and steering columns. The components of these subsystems may include steering wheels, Energy-Attenuating (EA) “spider brackets”, horn assemblies, attachment provisions for an airbag, and any attached switches for items such as cruise control, radio controls, and turn signals. This document provides EA steering teams with a reference from which to extract previously derived requirements to specify EA steering fit, form, and function to obtain the steering subsystem design intent. Some requirements in this document lack specificity in order to ensure the engineering team derives and tailors specific requirements addressing the particular vehicle configuration and operational conditions. For any given case, it is expected that these requirements and associated criteria will be tailored to support the particular ground vehicle design and operational requirements.

2. APPLICABLE DOCUMENTS

2.1 General. The documents listed in this section are specified in sections 3 and 4 of this specification. This section does not include documents cited in other sections of this specification or recommended for additional information or as examples. While every effort has been made to ensure the completeness of this list, document users are cautioned that they must meet all specified requirements of documents cited in sections 3 and 4 of this specification, whether or not they are listed.

2.2 Government documents.

2.2.1 Specifications, standards, and handbooks. The following specifications, standards, and handbooks form a part of this document to the extent specified herein. Unless otherwise specified, the issues of these documents are those cited in the solicitation or contract.

FEDERAL STANDARDS

FED-STD-313	-	Material Safety Data, Transportation Data and Disposal Data for Hazardous Materials Furnished to Government Activities
-------------	---	--

DEPARTMENT OF DEFENSE SPECIFICATIONS

MIL-DTL-53072	-	Chemical Agent Resistant Coating (CARC) System Application Procedures and Quality Control Inspection
MIL-DTL-83133	-	Turbine Fuel, Aviation, Kerosene Type, JP-8 (NATO F-34), NATO F-35, and JP-8+100 (NATO F-37)
MIL-PRF-2104	-	Lubricating Oil, Internal Combustion Engine, Combat/Tactical Service

MIL-PRF-32564

MIL-PRF-46170 - Hydraulic Fluid, Rust Inhibited, Fire Resistant, Synthetic Hydrocarbon Base, NATO Code No. H-544

DEPARTMENT OF DEFENSE STANDARDS

MIL-STD-810 - Environmental Engineering Considerations and Laboratory Tests
 MIL-STD-889 - Dissimilar Metals
 MIL-STD-1472 - Human Engineering
 MIL-STD-1916 - DOD Preferred Methods for Acceptance of Product

(Copies of these documents are available online at <http://quicksearch.dla.mil/>).

2.2.2 Other Government documents, drawings, and publications. The following other Government documents, drawings, and publications form a part of this document to the extent specified herein. Unless otherwise specified, the issues of these documents are those cited in the solicitation or contract.

CODE OF FEDERAL REGULATIONS

29 CFR 1910.1200 - Occupational Safety and Health Standard, Subpart Z toxic and hazardous substances
 40 CFR 355, Appendix A & B - List of Extremely Hazardous Substances and Their Threshold Planning Quantities
 40 CFR 372.65 Subpart D - Specific Toxic Chemical Listings
 49 CFR 393.209 - Steering Wheel Systems
 49 CFR 571.203 - Impact Protection for the Driver from the Steering Control System (FMVSS 203)
 49 CFR 571.204 - Steering Control Rearward Displacement (FMVSS 204)
 49 CFR 571.302 - Flammability of Interior Materials (FMVSS 302)

(Copies of these documents are available from <https://www.gpo.gov/>).

MIL-PRF-32564

U.S. ARMY TANK-AUTOMOTIVE RESEARCH, DEVELOPMENT, AND ENGINEERING CENTER (TARDEC) TECHNICAL REPORTS (TR)

TR 27790	-	Occupant Centric Platform (OCP) TECD Enhanced Injury Assessment Reference Values
NATICK/TR-14/019	-	Characterizing the Size of the Encumbered Soldier

(Copies of these documents are available online at <http://www.dtic.mil>)

2.3 Non-Government publications. The following documents form a part of this document to the extent specified herein. Unless otherwise indicated, the issues of these documents are those cited in the solicitation or contract.

INTERNATIONAL ORGANIZATION FOR STANDARDIZATION (ISO)

ISO 17025	-	General Requirements for the Competence of Testing and Calibration Laboratories
-----------	---	---

(Copies of these documents are available from www.iso.org)

AMERICAN SOCIETY FOR TESTING AND MATERIALS (ASTM) INTERNATIONAL

ASTM D975	-	Standard Specification for Diesel Fuel Oils
ASTM D1141	-	Standard Practice for the Preparation of Substitute Ocean Water

(Copies of these documents are available from www.astm.org).

FORD MOTOR COMPANY

Ford FLTM BN 161-01	-	Steering Wheel Wear Rub Test
---------------------	---	------------------------------

(Copies of these documents are available from www.ihs.com).

2.4 Order of precedence. Unless otherwise noted herein or in the contract, in the event of a conflict between the text of this document and the references cited herein, the text of this document takes precedence. Nothing in this document, however, supersedes applicable laws and regulations unless a specific exemption has been obtained.

3. REQUIREMENTS

3.1 First article inspection. When specified in Table IV of this document, first article inspection of sample items shall be executed by demonstration, examination, or test of designated performance requirements.

MIL-PRF-32564

3.2 Materials. The contractor shall select materials capable of meeting all requirements stated herein. Materials shall be free from defects which would adversely affect the performance or maintainability and safety of individual components or the overall assembly.

3.3 Hazardous material. Material Safety Data Sheets (MSDS) shall be provided to the Government Procuring Agency (GPA) in accordance with FED-STD-313. Asbestos, beryllium, Class I and Class II Ozone Depleting Substances (ODS), hexavalent chromium, cadmium, mercury, lead, radioactive materials, and other Group 1 Agents classified as "carcinogenic to humans" by the International Agency for Research on Cancer (IARC) Monographs shall not be present in or on any delivered materials, including alloys; required for the operation and sustainment; or used in final manufacture and assembly processes. The following exceptions are allowed without prior approval from the Government: Cadmium and hexavalent chromium on electrical connectors and back shells used to mate with cadmium electrical connectors on Government Furnished Equipment (GFE). The U.S. Environmental Protection Agency maintains an online list of toxic chemicals and hazardous substances. Type I, II and III materials shall comply with the requirements stated in: 29 CFR 1990, 40 CFR 355, Appendices A & B and 40 CFR 372.65 Subpart D.

3.4 Reporting. The results for all tests performed on the steering wheel/steering subsystem shall be documented and submitted to the GPA.

3.5 Design. The steering wheel/steering subsystems shall be designed to meet the requirements as outlined in Section 3.

3.6 Sample size and lot formation. The number of samples and lot formation shall be in accordance with the requirements as specified in MIL-STD-1916.

3.7 Test laboratories. Test and evaluation of US Army military vehicle steering subsystems shall be conducted using an accredited laboratory according to ISO 17025, or a Government laboratory with equivalent internal assessment.

3.8 Test and evaluation (T&E).

3.8.1 Energy attenuation. The steering subsystem shall provide energy attenuation to protect the driver's abdomen and shall be evaluated in a representative frontal crash test and/or computer simulation referencing requirements in 49 CFR 571.203. The steering subsystem shall provide energy attenuation and protect a driver's femur during a representative underbody blast test and/or computer simulation, as assessed in the injury criteria documented in "ARL SLAD WSB, Injury Criteria for the Analysis of Soldier Survivability in Accelerative Events, April 2012, DIST D". Injury criteria in crash, blast and rollover simulations and/or physical tests will be assessed using the fully encumbered 50th percentile male Anthropomorphic Test Devices (ATD) in accordance with the encumbered ATD information contained in NATICK/TR-14/019.

(For additional information on injury criteria, please refer to Section 6.3)

MIL-PRF-32564

3.8.2 Steering control rearward displacement. The upper end of the steering column and the steering shaft shall not be displaced in a rearward direction by more than what is permitted in 49 CFR 571.204.

3.8.3 Flammability of EA steering subsystem. The EA steering subsystem shall be made of materials having a flashpoint greater than 100° C, meet 49 CFR 571.302 requirements, and shall not contain:

- a. self-reactive materials when wetted,
- b. spontaneously combustible materials with or without contact with water,
- c. pyrophoric or self-heating materials,
- d. materials which give off flammable or toxic gas.

3.8.4 Survivability and human factors. EA steering components shall be designed to meet the human factors requirements IAW MIL-STD-1472, or as specified in the contract.

3.8.5 Steering wheel weight and space claim. The weight and space claim requirements of the EA steering subsystem shall be as specified by the contract. This includes the space necessary to accommodate the central 90% of the Soldier population as found in MIL-STD-1472 and the fully encumbered driver IAW NATICK/TR-14/019.

3.8.6 Subsystem safety.

3.8.6.1 Inadvertent actuation. The EA steering subsystem shall be designed as not to cause any malfunctioning of any other components of the platform if inadvertently actuated.

3.8.7 Integration and maintainability.

3.8.7.1 Standard connections. The EA steering subsystem shall have non-proprietary connections.

3.8.7.2 Steering wheel puller. The EA steering subsystem shall be removable by tools available in a General Mechanics Tool Kit (GMTK) or standard tools (not special tools) to remove the steering wheel from the hub or as specified in the contract.

3.8.7.3 Exposed aluminum. Any exposed aluminum on the EA steering subsystem shall be anodized black.

3.8.8 Steering wheel torque. The EA steering subsystem shall be able to withstand, without failure, loading conditions associated with attaching the steering wheel to the torque specified in the steering sub-assembly Technical Data Package (TDP).

MIL-PRF-32564

3.8.9 Welding. All welds shall be IAW welding procedures that are specified in the steering sub-assembly TDP.

3.8.10 Steering subsystem.

3.8.10.1 Steering wheel durability in bending. Mount the steering wheel on a shaft and rotate the steering wheel at a rate of 30 rpm while applying a 311 ± 5 N (70 ± 1.1 pounds-force) load perpendicular to the steering wheel rim as shown in Figure 1, for 30,000 revolutions.

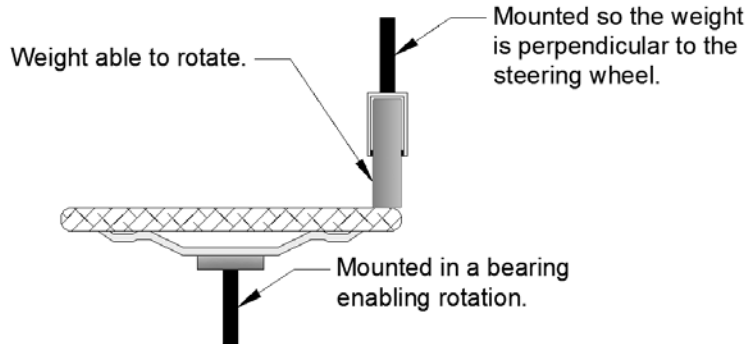

Figure 1, Steering wheel durability in bending

3.8.10.2 Hub connection strength. The steering wheel (welded or not welded) shall be anchored to a fixture as representatively shown in Figure 2 (may utilize any mounting method which ensures safety of personnel in and around the area of the test). An axial load of 26.7 ± 0.03 kN ($6,000 \pm 7$ pounds-force) shall be applied to the steering wheel hub.

3.8.10.2.1 Test hub connection to failure. If hub is welded to the wheel, apply an axial load to the hub as shown in the test setup in Figure 2. The load shall be increased until the hub connection fails.

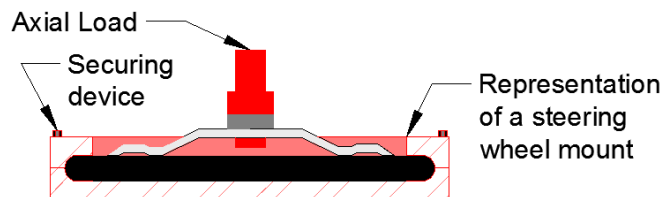

Figure 2, Hub weld strength

3.8.10.3 Rim tangential rigidity. The steering wheel shall be mounted to a shaft. The shaft shall be clamped and/or pinned as to not allow movement. A device no greater than $\frac{1}{2}$ " wide, shall be clamped around the steering wheels vertical axis and a $1,335 \pm 23$ N (300 ± 5 pounds-force) load tangential to the rim one time in each direction (clockwise and counterclockwise)

MIL-PRF-32564

applied. The load shall be perpendicular to the shaft, and where the rim is *least* supported by the spokes as depicted in Figure 3.

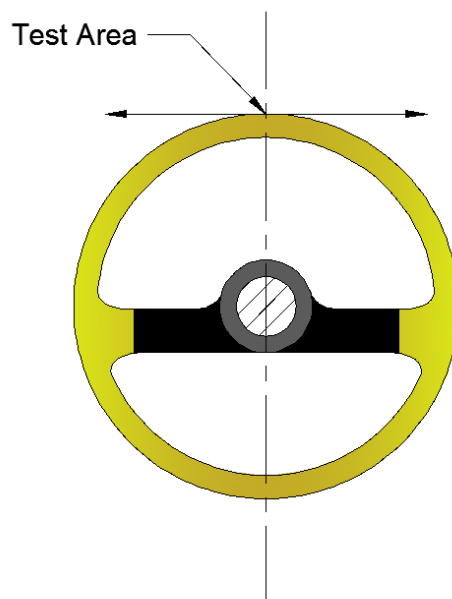

Figure 3, Rim tangential rigidity

3.8.10.4 Fore and aft bending strength. The steering wheel shall be mounted to a shaft. The supporting shaft shall be clamped and/or pinned as to not allow movement. The steering wheel shall be sufficiently stiff and durable to withstand an alternating fore and aft load of 445 ± 5 N (100 ± 1 pounds-force) as depicted in Figure 4. The load shall be perpendicular to the least supported area of the wheel rim arc and applied at a load cycle frequency of 5 ± 0.1 Hz for 10 minutes \pm 2 seconds.

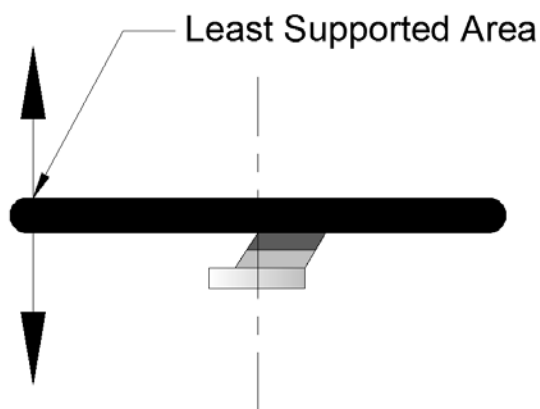

Figure 4, Fore and aft bending strength

MIL-PRF-32564

3.8.10.5 Driver entry loading. Mount a steering wheel to a steering shaft as it would be installed in a vehicle (does not have to be in a vehicle but, the steering shaft shall be in a durable fixture). The supporting shaft shall be clamped and/or pinned as to not allow movement. Apply a load of 1338 ± 10 N (300 ± 2.25 pounds-force), then removing it from the surface at 2 cycles per second for 55,000 cycles at a 45 degree angle away from the wheel plane and axis, at 225 degrees clockwise from the top of the wheel (see Figure 5).

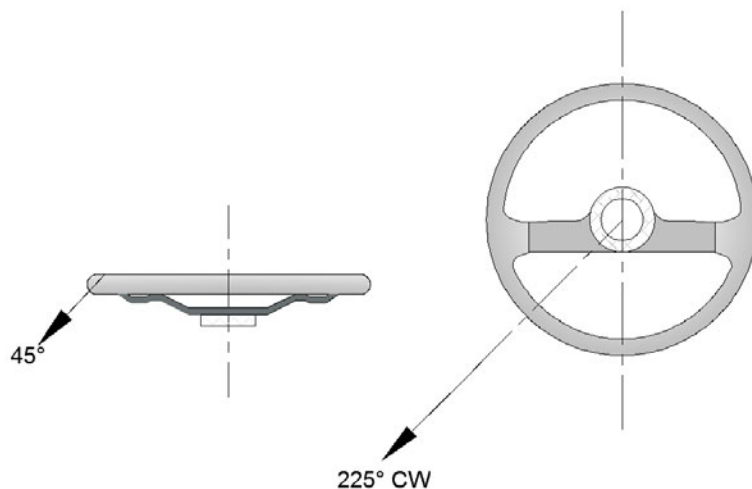

Figure 5, Driver entry loading

3.8.10.6 Torsion durability. The steering wheel shall be mounted to a shaft. The supporting shaft shall be clamped and/or pinned as to not allow movement. A reversing load of 667 N (150 pounds) shall be applied tangential to the rim for 30,000 cycles at 1 Hz. A cycle is one load application in each direction. See Figure 6.

MIL-PRF-32564

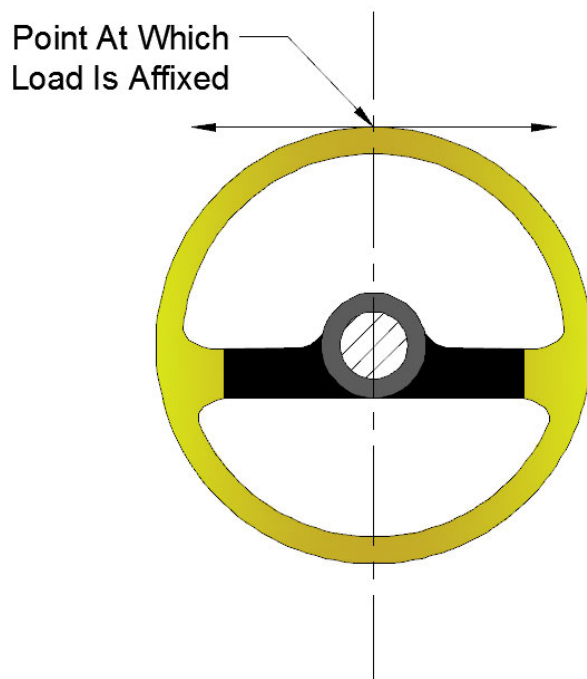

Figure 6, Torsion durability.

3.8.10.7 Steering wheel rub wear resistance. Ford FLTM BN 161-01 shall be used to test the EA steering wheel for wear resistance.

3.8.10.8 Molding (trim). If the steering wheel has molding, it shall be inspected for evidence of mold material separation and gaps (mold process error).

3.8.11 EA steering system.

3.8.11.1 EA steering system components. Serviceable EA components shall be removed and reinstalled a minimum of 5 consecutive times without actuation or damage disabling their function.

3.8.11.2 Vibration test. The EA steering system shall be capable of withstanding the frequencies and “g” forces as described in Table I. Test the EA steering system using an assembled steering wheel and steering column (down to but excluding the gearbox) with all components as if it were installed in a vehicle. The test shall be performed IAW MIL-STD-810, Method 514, Procedure I. The steering wheel, including any controls located on the steering wheel (e.g., radio, cruise control) and any airbag shall have a resonant frequency above 25 Hz.

MIL-PRF-32564

Table I, Vibration test steps

<u>Test</u>	<u>Time</u>	<u>Frequency (Hz)</u>	<u>Maximum Acceleration (G's)</u>	<u>Displacement</u>
1	10 seconds/step (up)	10-40 (1 Hz steps)	-	4 mm (0.16 inch)
2	16 hours	16	2.5	-
3	4 hours.	25	6.8	-
4	10 seconds/step (down)	40-10 (1 Hz steps)	-	4 mm (0.16 inch)

3.8.11.3 Horn cycling. The horn shall be electrically powered with the circuit being similar to as if it were installed in a vehicle. The horn switch(s) with the covering pad installed shall be actuated using a force of 35 ± 2.25 N (7.8 ± 0.50 pounds-force) applied through an area of 161 ± 1 mm square (0.25 ± 0.04 inch square) at 1 Hz until 100,000 cycles (circuit closed then circuit opened) are achieved. After 100,000 cycles the horn switch shall be closed and tested to see if continuity exist.

3.8.11.4 Function test. The steering wheel, steering shaft, and any components mounted to them shall be able to rotate a minimum of 360 degree in both clockwise and counterclockwise directions.

3.8.12 Freeze/thaw. The EA steering subsystem shall meet the following Freeze/Thaw requirements IAW MIL-STD-810 Method 524, Procedure III. A minimum of three cycles shall be completed. The initial start conditions of a sample shall be at ambient conditions. The configuration of the steering subsystem shall be outside of its shipping/storage container and set up in its normal operating mode. Hydraulic connections to the EA steering subsystem shall be capped and shall be mounted on a holding fixture. Temperature changes shall not exceed 2° C (3.6° F) per minute. The sample shall be allowed to equilibrate to ambient laboratory conditions for 24 hours before performing verification procedures. The cycle shall follow, in order, the temperatures, duration, and relative humidity percent (RH %) as stated in Table II. A stabilization time of 2 hours shall be allowed between each temperature range prior to the start of the duration time.

Table II, Freeze/Thaw temperatures, duration, and RH % testing

Temperature Range	Duration	RH %
$71 \pm 2^{\circ}$ C ($160 \pm 4^{\circ}$ F)	12 hours	2 to 7
$-19 \pm 2^{\circ}$ C ($-2 \pm 4^{\circ}$ F)	12 hours	95 to 100
$41 \pm 2^{\circ}$ C ($105 \pm 4^{\circ}$ F)	7 hours	75 to 80
$-6 \pm 2^{\circ}$ C ($21 \pm 4^{\circ}$ F)	7 hours	95 to 100
$43 \pm 2^{\circ}$ C ($110 \pm 4^{\circ}$ F)	12 hours	40 to 45
$-51 \pm 2^{\circ}$ C ($-60 \pm 4^{\circ}$ F)	7 hours	95 to 100
$30 \pm 2^{\circ}$ C ($86 \pm 4^{\circ}$ F)	7 hours	40 to 50

MIL-PRF-32564

3.8.13 Humidity. The EA steering subsystem shall meet all operational performance requirements during exposure to relative humidity of 95% to 100% as tested IAW MIL-STD 810, Method 507, Procedure II – Aggravated procedure, of non-hazardous materials for ten 24-hour cycles (no testing during this time frame). The initial start conditions of a sample shall be at ambient conditions. The configuration of the steering subsystem shall be outside of its shipping/storage container and set up in its normal operating mode. Hydraulic connections to the EA steering subsystem shall be capped and shall be mounted on a holding fixture.

3.8.14 Salt fog. Test corrosive resistance IAW MIL-STD-810, Method 509, for alternating 48-hour periods of salt fog exposure and drying conditions for a minimum of ten 48-hour periods (one wet then one dry). The configuration of the steering subsystem shall be outside of its shipping/storage container and set up in its normal operating mode. Hydraulic connections to the EA steering subsystem shall be capped and shall be mounted on a holding fixture.

3.8.15 Solar radiation. The configuration of the steering subsystem shall be outside of its shipping/storage container and set up in its normal operating mode. Hydraulic connections to the EA steering subsystem shall be capped and shall be mounted on a holding fixture. Perform solar radiation test IAW MIL-STD-810, Method 505, Procedure II under worldwide deployment temperature ranges using the accelerated test of ten 24 hour cycles.

3.8.16 Fungal resistance. The EA steering subsystem shall test for fungal resistance IAW MIL-STD-810, using common **Aspergillus flavus**, **Aspergillus Versicolor** and **Chaetomium Globosum** fungi per Method 508 procedures for a duration of 30 days. The configuration of the steering subsystem shall be outside of its shipping/storage container and set up in its normal operating mode. Hydraulic connections to the EA steering subsystem shall be capped and shall be mounted on a holding fixture.

3.8.17 Resistance to fluid contamination. The EA steering subsystem cover material exposed surface shall be subjected to contamination IAW MIL-STD-810, Test Method 504, Contamination by Fluids, Procedure II, Occasional Contamination using the following fluid chemicals in Table III (below).

Table III, Contamination by fluids

Fluid Chemicals		Source Document
1	Diesel Fuel (DL-2)	ASTM D975-14
2	Engine Oil, SAE 15W40	MIL-PRF-2104
3	JP-8, Aviation, kerosene type	MIL-DTL-83133
4	Sea Water (Simulated) or 5% NaCl Solution	ASTM D1141-98 (Reaffirmed 2013)
5	Hydraulic Fluid	MIL-PRF-46170

MIL-PRF-32564

3.9 Cleanability. The steering wheel and horn pad assembly shall be able to be cleaned with a mild solution of soap and water. They shall be compatible with commercial ammoniated cleaning and appearance restoration products. Apply of cleaning agent to cheesecloth or suitable white cloth and rub back and forth ten times in three separate areas on the wheel rim and the horn pad surface. The length of the rub shall be a minimum of 25.4 mm (1 inch), and the force on the cloth pressing on the surfaces shall be approximately 5 N (1.1 pounds-force).

4. VERIFICATION

4.1 First article rejection. If any sample undergoing first article inspection fails to comply with the performance requirements as specified in Section 3, the sample and lot shall be rejected.

4.2 Materials. Verify materials used are in compliance with this specification.

4.3 Hazardous material. Verify materials used are in compliance with references as specified in 3.3 this specification.

4.4 Reporting. The GPA shall verify tests have been performed by examination and analysis of documentation.

4.5 Design. Design verification shall be performed by analysis of performance requirements using ISO and/or SAE and/or other standard engineering practices as stated in the contract.

4.6 Sample size and lot formation. If the number of samples per lot does not conform to MIL-STD-1916, the entire batch of components shall be retested with the correct number of samples per lot at no cost to the Government.

MIL-PRF-32564

Table IV, Cross reference matrix

<u>METHOD OF VERIFICATION</u> 1 - Examination 2 - Analysis 3 - Demonstration 4 - Test		<u>TYPE OF VERIFICATION</u> A - Design verification B - First article						
Requirement		Verify	Verification				Class	
			1	2	3	4	A	B
3.1	First article inspection	4.1	X	X	X	X	X	X
3.2	Materials	4.2	X	X	X	X	X	X
3.3	Hazardous material	4.3		X		X	X	X
3.4	Reporting	4.4	X	X	X	X	X	X
3.5	Design	4.5	X				X	
3.6	Sample size and lot formation	4.6	X	X	X	X	X	X
3.7	Test laboratories	4.7	X	X	X	X	X	X
3.8.1	Energy attenuation	4.8.1		X		X	X	X
3.8.2	Steering control rearward displacement	4.8.2		X		X	X	X
3.8.3	Flammability of EA steering subsystem	4.8.3		X	X	X	X	X
3.8.4	Survivability and human factors	4.8.4	X	X			X	X
3.8.5	Steering wheel weight and space claim	4.8.5	X	X			X	X
3.8.6.1	Inadvertent actuation	4.8.6.1			X		X	X
3.8.7.1	Standard connections	4.8.7.1	X				X	X
3.8.7.2	Steering wheel puller	4.8.7.2	X		X		X	X
3.8.7.3	Exposed aluminum	4.8.7.3	X				X	X
3.8.8	Steering wheel torque	4.8.8			X			X
3.8.9	Welding	4.8.9				X	X	X
3.8.10.1	Steering wheel durability in bending	4.8.10.1				X		X
3.8.10.2	Hub connection strength	4.8.10.2				X		X
3.8.10.2.1	Test hub connection to failure	3.8.10.2.1				X		X
3.8.10.3	Rim tangential rigidity	4.8.10.3				X		X
3.8.10.4	Fore and aft bending strength	4.8.10.4				X		X
3.8.10.5	Driver entry loading	4.8.10.5				X		X
3.8.10.6	Torsion durability	4.8.10.6				X		X
3.8.10.7	Steering wheel rub wear resistance	4.8.10.7				X		X
3.8.10.8	Molding (trim)	4.8.10.8	X					X
3.8.11.1	EA steering system components	4.8.11.1				X		X
3.8.11.2	Vibration test	4.8.11.2				X		X
3.8.11.3	Horn cycling	4.8.11.3				X		X
3.8.11.4	Function test	4.8.11.4				X		X
3.8.12	Freeze/thaw	4.8.12				X		X
3.8.13	Humidity	4.8.13				X		X
3.8.14	Salt fog	4.8.14				X		X
3.8.15	Solar radiation	4.8.15				X		X
3.8.16	Fungal resistance	4.8.16				X		X
3.8.17	Resistance to fluid contamination	4.8.17				X		X
3.9	Cleanability	4.9				X		X

MIL-PRF-32564

4.7 Test laboratories. Verify laboratory accreditation certificates IAW section 3.4 have been submitted to the procuring GPA 30 days prior to commencement of test and evaluation. If an accredited laboratory certificate has not been submitted prior to the 30th day before commencement of test and evaluation on the steering wheel or its components, the contractor shall cease operations pertaining to the manufacture of the steering wheel and/or its components until proper documentation is submitted to the GPA.

4.8 Test and evaluation (T&E).

4.8.1 Energy attenuation. If energy attenuation of the steering subsystem does not meet the threshold boundaries as outlined in the test requirements in Section 3.8.1, the sample and lot shall be rejected.

4.8.2 Steering control rearward displacement. If the upper end of the steering column and the steering shaft are displaced in a rearward direction by more than what is permitted in 49 CFR 571.204, the sample and lot shall be rejected.

4.8.3 Flammability of EA steering subsystem. Use of materials having a flashpoint of 100° C or less, self-reactive materials when wetted, spontaneously combustible materials, pyrophoric or self-heating materials, materials which give off flammable or toxic gas, or not meeting 49 CFR 571.302 requirements shall cause the sample and lot to be rejected.

4.8.4 Survivability and human factors. Components of the EA steering components not in design compliance with the human factors requirements contained in MIL-STD-1472 and as specified in the contract shall cause the sample and lot to be rejected.

4.8.5 Steering wheel weight and space claim. When the weight and space claim requirements of the EA steering subsystem are not met, the sample and lot shall be rejected.

4.8.6 Subsystem safety.

4.8.6.1 Inadvertent actuation. A failure of the electrically controlled features of the steering subsystem potentially causing actuation of other platform components shall cause the sample and lot to be rejected.

4.8.7 Integration and maintainability.

4.8.7.1 Standard connections. The use of proprietary connections shall cause the design to be rejected.

4.8.7.2 Steering wheel puller. If the steering wheel cannot be removed using a generic COTS steering wheel puller kit, the design shall be rejected.

4.8.7.3 Exposed aluminum. Exposed aluminum not anodized black shall result in the sample and lot being rejected.

MIL-PRF-32564

4.8.8 Steering wheel torque. A steering wheel fastener that does not meet the minimum torque requirements of the TDP shall result in the sample and lot being rejected.

4.8.9 Welding. Welds failing the requirements as specified in the steering TDP shall result in the sample and lot being rejected.

4.8.10 Steering subsystem.

4.8.10.1 Steering wheel durability in bending. Verify the steering wheel rim does not deflect more than 10 mm (0.39 inches) from the original shape in the wheel plane after rotating the wheel 30,000 revolutions, Verify without aid of magnification from not more than 200 mm (8 inches) away, there are no visible cracks on any exposed surface. If the preceding cracking condition exists, the sample and lot shall be rejected.

4.8.10.2 Hub weld strength. If the hub connection does not reach the specified axial load, the sample and lot shall be rejected.

4.8.10.2.1 Test hub connection to failure. When the sample hub breaks away, the fractured surface shall be examined for a minimum of 75 percent parent material remaining along the weld. The sample and lot shall be rejected if hub connection has less than 75 percent of the parent material.

4.8.10.3 Rim tangential rigidity. Permanent deformation from the original shape of 13.0 mm (0.5 inch) or more shall be cause for rejection of the sample and the lot.

4.8.10.4 Fore and aft bending strength. The steering wheel rim having permanent deformation of more than 10 mm (0.39 inches) shall be cause for rejection of the sample and lot.

4.8.10.5 Driver entry loading. A permanent deformation of 25 mm (1 inch) or more relative to the original plane of the rim shall result in rejection of the sample and lot.

4.8.10.6 Torsion durability. Permanent deformation, measuring the outside diameter at the vertical centerline must be less than 2.5 mm (0.1 inch). Otherwise, the sample and lot shall be rejected.

4.8.10.7 Steering wheel rub wear resistance. If the EA steering wheel fails to meet the requirements in Ford FLTM BN 161-01, the sample and lot shall be rejected.

4.8.10.8 Molding (trim). When or if the molding has any delamination or cracking greater than 2 mm (0.08 inch) in length or missing segments greater than 4 mm square (0.16 inch square), then the sample and lot shall be rejected.

MIL-PRF-32564

4.8.11 EA steering system.

4.8.11.1 EA steering system components. If a component is damaged prior to being removed and replaced 5 times, the EA steering system shall be rejected.

4.8.11.2 Vibration test. If any of the following occur, the sample and lot shall be rejected:

- a. the horn switch activates or the airbag deploys (if so equipped)
- b. steering wheel attaching fasteners loosen to less than 75 percent of the original torque as specified in the TDP, or
- c. cracking or delamination develop in the steering wheel component(s).
- d. Having a resonance frequency less than 25 Hz.

4.8.11.3 Horn cycling. If the horn switch fails before 100,000 cycles or the circuit does not have continuity after 100,000 cycles or the horn cover/pad is cracked or distorted after 100,000 cycles, the sample and lot shall be rejected.

4.8.11.4 Function test. If the EA steering system binds or does not freely rotate 360 degrees in both directions, the sample and lot shall be rejected.

4.8.12 Freeze/thaw. There should be no loss of function due to broken or degraded molded parts. The steering components shall exhibit no visible changes in mechanical or electrical properties. If any of these conditions exist, the sample and lot shall be rejected.

4.8.13 Humidity. Inspect the sample for condensation or free water (short circuits possible), de-laminated materials, swelling of materials, oxidation and/or galvanic corrosion of metals, breakdown of coatings, and changes in friction coefficients (binding or sticking). If any of these conditions exist, the sample and lot shall be rejected.

4.8.14 Salt fog. Electrically test for short circuits, measure friction coefficients of components, and disassemble sample and inspect for signs of corrosion. If the sample has a short circuit, a difference in friction coefficients of greater than 0.10, or has visible corrosion without the aid of magnification of not more than 200 mm (8 inches) away, the sample and lot shall be rejected.

4.8.15 Solar radiation. The sample shall be inspected for any signs of actinic (photo degradation) effects of exposure on test sample. If there are actinic effects or any of the following are found, the sample and lot shall be rejected:

- a. Jamming or loosening of moving parts.
- b. Weakening of solder joints or glued parts.

MIL-PRF-32564

- c. Changes in strength and elasticity.
- d. Malfunction of linkage devices.
- e. Loss of seal integrity.
- f. Changes in electrical or electronic components.
- g. Premature actuation of electrical contacts.
- h. Changes in characteristics of elastomers and polymers.
- i. Blistering, peeling, or de-lamination composites/surface laminates.
- j. Softening of materials.
- k. Sweating of materials.
- l. Difficulty in handling.

4.8.16 Fungal resistance. Inspect for any fungus growth IAW MIL-STD-810, Table in Method 508 labeled **Evaluation scheme for visible effects**. Analyze any growth to determine the rating on a scale of 0 (zero) to 4. Zero being no growth, and 4 being total coverage. The growth rating shall not exceed a rating 1. If the growth rating exceeds a rating of 1 the sample and lot shall be rejected.

4.8.17 Resistance to fluid contamination. Verify the EA steering subsystem is compatible with the fluids listed in Table III. If the EA steering subsystem deteriorates to the point of binding or slackening of moving parts, differential contraction or expansion rates or induced strain rates of dissimilar materials, deformation or fracture of components, cracking of surface coatings, seal or gasket failures, failure of insulation protection, crazing or swelling of plastics and rubbers, adhesion failures, paint/protective coating removal, corrosion, melting/decomposition, interruption of electrical continuity, or increase in electrical resistance the sample and lot shall be rejected.

4.9 Cleanability. Compare the cheesecloth to the grey scale, Figure 7. If the cheesecloth is darker than "4", the sample and lot shall be rejected.

MIL-PRF-32564

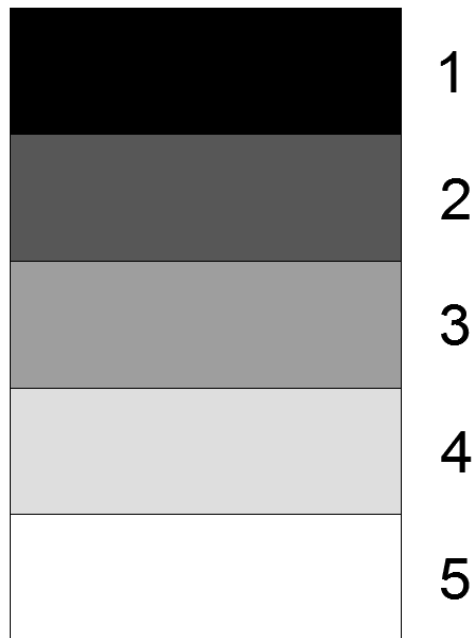

Figure 7, Grey scale

5. PACKAGING

5.1 Packaging requirements. For acquisition purposes, the packaging requirements shall be as specified in the contract or order. When packaging of materiel is to be performed by DoD or in-house contractor personnel, these personnel need to contact the responsible packaging activity to ascertain packaging requirements. Packaging requirements are maintained by the Inventory Control Point's packaging activity within the Military Service of Defense Agency, or within the military service's system commands. Packaging data retrieval is available from the managing Military Department's or Defense Agency's automated packaging files, CD-ROM products, or by contacting the responsible packaging activity.

6. NOTES

6.1 Reporting format. All test reports and supporting documentation will be submitted to the GPA in writing and will entail the following minimum information.

- a. Contractor's company name, address, DUNS number, CAGE code.
- b. Contractor's point of contact, name, address, office telephone, mobile telephone and email address.
- c. Laboratory name, accreditation certification entity, and address.
- d. Item description, name, type, manufacturer (name, address, and point of contact).
- e. Date of test and date of report.

MIL-PRF-32564

- f. Test report number.
- g. Sample identifier (lot and item number).
- h. Sample configuration inspection results.
- i. Pass or fail status according to contractual requirement(s).
- j. Test specification, test title and test description.
- k. Laboratory test observations and remarks.

l. Authorized laboratory signature and certification the test results are obtained after testing, in accordance with accredited laboratory test procedures and accurate to the best of the laboratory test entities capabilities.

6.2 Definitions.

Analysis	an element of verification that uses established technical or mathematical models or simulations, algorithms, charts, graphs, circuit diagrams, or other scientific principles. Method is also performed by referring to a computerized drawing whether or not the drawing is stored electronically.
ATD	Anthropomorphic Test Devices
CAGE	Commercial and Government Entity
COTS	Commercial Off The Shelf
CFR	Code of Federal Regulations
DUNS	Data Universal Numbering System
Demonstration	an element of verification that involves the actual operation of an item to provide evidence that the required functions were accomplished under specific scenarios. The items may be instrumented and performance monitored.
EA steering subsystem	Energy-Attenuating (EA) steering wheels, EA “spider brackets” and attaching hardware.
Examination	an element of verification that is generally nondestructive and typically includes the use of sight,

MIL-PRF-32564

	hearing, smell, touch, and taste; simple physical manipulation and mechanical and electrical gauging and measurement.
Fully Encumbered Driver	describes a soldier wearing a uniform, body armor, ammo packs, helmet, and combat boots
Full Range of Occupants	the central 90 percent of the Soldier population as defined in MIL-STD-1472, with the specified Soldier equipment kit..
GPA	Government Procuring Agency
Hz	Hertz - is the unit of frequency in the International System of Units (SI) and is defined as one cycle per second
IAW	In Accordance With.
Inspection	the examination of supplies and services to determine whether they conform to specified requirements.
ISO	International Organization for Standardization
MSDS	Material Safety Data Sheets
N	Newton – a measurement of force
Occupant Centric Platform (OCP)	TARDEC program with the design philosophy that considered the soldier first and had the goals of integrating occupant centric protection technologies and designing the vehicle to support the soldier and their mission
Steering column	the housing enclosing the steering shaft.
Steering control	the steering device, usually the steering wheel, which is actuated by the driver.
Steering shaft	the component which transmits to the steering gear the torque applied to the steering control.
Steering system	the aggregate comprising the steering control, the steering column, any “spider bracket”, the assembly accessories, the steering shaft, the steering gear

MIL-PRF-32564

	housing, and all other components such as those designed to contribute to the absorption of energy in the event of impact against the steering control.
Stroke zone of the EA	the volumetric space claim required for the unobstructed stroke of steering subsystem.
TDP	Technical Data Package
Test	Method is performed by utilizing measurement instruments on the item under test and operating the item in a manner that allows the instrumentation to collect data to show requirement verification.
T&E	Test and Evaluation
Threshold requirement	Identified by the word "shall" and indicates a minimum acceptable performance level that must be met by the EA steering subsystem unless otherwise stated
TR	Technical Report
VDC	Voltage direct current

6.3 Injury criteria. Injury criteria for the 5th percentile female and 95th percentile male can be evaluated IAW TR 27790. The OCP TECD Report TR-27790 "Enhanced Injury Assessment Reference Values" was created to meet the OCP TECD program challenge statement of "designing for and protecting the Soldier population". The OCP Enhanced IARVs (e-IARVs) have not been adopted by US Department of Defense (DoD) Live Fire Testing & Evaluation (LFT&E), Army Evaluation Command (AEC), nor The Office of the Director, Operational Test and Evaluation (DOT&E), as of 19-September-2016, for use current and/or new acquisition programs. As described in the report, the injury criteria developed for the OCP TECD program utilized existing biomedical research for the 5th percentile female, 50th percentile male, and 95th male. This report recommends that PEOs, PMs, and RDECs may integrate these e-IARVs or extract information into contracting documents as appropriate in conjunction with the currently accepted injury criteria. These values are to be utilized for informational and developmental purposes only.

6.4 Certification. The EA steering subsystem will be certified to meet the requirements of this specification by Inspection, Analysis, Demonstration, or Test during the verification evaluations.

6.5 T&E photographic and video. The contractor will provide pictures or videos of the test set-up, equipment and test samples and submit to the GPA, as part of the test report submission.

MIL-PRF-32564

6.6 Reporting surrogate test reports. Pre-existing surrogate test reports and documentation will be submitted by the contractor, as verification documentation, within 30 days of contract award, upon the written consent of the GPA on or before the start of work meeting.

6.7 Electronic transfer of information. The contractor will obtain prior written consent by the GPA to allow for electronically transferred information. The means of electronic transfer and format will be clearly stated in the contractor's written request for electronic transfer consent by the GPA.

6.8 Subject term (key word) listing.

- Gear
- Horn
- Shaft
- Spider brackets
- Survivability
- Switch

MIL-PRF-32564

Custodian:

Army – AT

Preparing Activity:

Army – AT

(Project # 2530-2016-001)

NOTE: The activities listed above were interested in this document as of the date of this document. Since organizations and responsibilities can change, you should verify the currency of the information above using the ASSIST Online database at <https://assist.dla.mil>.