

INCH-POUND

MIL-PRF-32150B

15 July 2013

SUPERSEDING

MIL-PRF-32150A

7 June 2007

PERFORMANCE SPECIFICATION
 STATIC AUTOMATIC BUS TRANSFER (SABT) SWITCH
 ON SURFACE AND SUBMARINE NAVAL VESSELS

This specification is approved for use by all Departments and Agencies of the Department of Defense.

1. SCOPE

1.1 Scope. This specification covers the Static Automatic Bus Transfer (SABT) Switch, herein referred to as the SABT (see 6.4.23) or the unit, or also referred to as a Solid State Automatic Bus Transfer (SSABT) Switch, for use on surface and submarine naval vessels. Requirements for Automatic Bus Transfer (ABT) Switches and Manual Bus Transfer (MBT) Switches are not covered in this specification. MIL-PRF-17773 specifies the requirements for ABTs and MBTs.

1.2 Classification. SABTs have the following characteristics: (Part or identifying number (PIN) codes are provided along with the classifications to avoid unnecessary duplication of information in 1.3.)

1.2.1 Voltage. SABT voltages are as follows:

Voltage	PIN Code
120 VAC	1
208 VAC	2
450 VAC	4
Other	6

1.2.2 Frequency. SABT frequencies are as follows:

Frequency	PIN Code
60 Hz	A
400 Hz	F

Comments, suggestions, or questions on this document should be addressed to: Commander, Naval Sea Systems Command, ATTN: SEA 05S, 1333 Isaac Hull Avenue, SE, Stop 5160, Washington Navy Yard DC 20376-5160 or emailed to CommandStandards@navy.mil, with the subject line "Document Comment". Since contact information can change, you may want to verify the currency of this address information using the ASSIST Online database at <https://assist.dla.mil>.

MIL-PRF-32150B

1.2.3 Configuration type. SABT configuration types are as follows:

Configuration Type (CT) Description	PIN Code
SABT has: (a) full phase protection (see 3.4.3.9 and 6.4.5) on normal bus and (b) is instantaneous (see 6.4.10) and (c) normal seeking and (d) without pickup and dropout frequency settings.	20
SABT has: (a) full phase protection (see 3.4.3.9 and 6.4.5) on normal bus and (b) is instantaneous and (c) normal seeking and (d) with pickup and dropout frequency settings.	21
SABT has: (a) full phase protection (see 3.4.3.9 and 6.4.5) on normal bus and (b) is instantaneous and (c) power seeking and (d) without pickup and dropout frequency settings.	22
SABT has: (a) full phase protection (see 3.4.3.9 and 6.4.5) on normal bus and (b) is instantaneous and (c) power seeking and (d) with pickup and dropout frequency settings.	23

Note: In-phase monitoring (see 6.4.8) is not used in 400 Hertz (Hz) SABTs on naval vessels.

1.2.4 Special features. SABT special features are as follows:

Special Feature	PIN Code
Special feature(s)	S
Special frequency	SF
Auxiliary contacts	AC
External control cable	ECC
No special feature(s)	X

1.2.5 Current rating. SABT current ratings are as follows:

Maximum Current Rating	PIN Code
025 to 400 amps	XXX

MIL-PRF-32150B

1.2.6 Cabinet integrity. SABB cabinet integrity is as follows:

Cabinet Integrity	PIN Code
Drip-proof	D
Splash-proof	S
Watertight	W
Drip-proof, extended enclosure	DE
Splash-proof, extended enclosure	SE
Watertight, extended enclosure	WE

1.3 Part or identifying number (PIN). PINs to be used for SABBs acquired to this specification are created as follows: (see 1.2.1 through 1.2.6 for PIN Code designations)

M Prefix	Specification Number	Hyphen	Voltage	Frequency	CT	Special Features	Current Rating (maximum)	Cabinet Integrity
M	32150	-	2	F	22	X	400	S
The example above (M32150-2F22X400S) is for a 208-volt, 400 Hz, instantaneous and power seeking, no special feature, 400-amp maximum current rating, splash-proof SABB.								

2. APPLICABLE DOCUMENTS

2.1 General. The documents listed in this section are specified in sections 3, 4, or 5 of this specification. This section does not include documents cited in other sections of this specification or recommended for additional information or as examples. While every effort has been made to ensure the completeness of this list, document users are cautioned that they meet all specified requirements cited in sections 3, 4, or 5 of this specification, whether or not they are listed.

2.2 Government documents.

2.2.1 Specifications, standards, and handbooks. The following specifications, standards, and handbooks form a part of this document to the extent specified herein. Unless otherwise specified, the issues of these documents are those cited in the solicitation or contract.

FEDERAL STANDARDS

FED-STD-595/26307 - Gray, Semigloss

DEPARTMENT OF DEFENSE SPECIFICATIONS

MIL-S-901 - Shock Tests, H.I. (High-Impact) Shipboard Machinery, Equipment, and Systems, Requirements for

MIL-E-917 - Electric Power Equipment Basic Requirements

MIL-E-2036 - Enclosures for Electric and Electronic Equipment, Naval Shipboard

MIL-DTL-15024 - Plates, Tags, and Bands for Identification of Equipment, General Specification for

MIL-P-15024/5 - Plates, Identification

MIL-DTL-16036 - Switchgear, Power, Low Voltage, Naval Shipboard

MIL-PRF-32150B

- MIL-PRF-19207 - Fuseholders, Extractor Post Type, Blown Fuse Indicating and Nonindicating, General Specification for
- MIL-PRF-19500/519 - Semiconductor Device, Diode, Light Emitting, Red Types, JAN1N6092, JANTX1N6092, JAN1N6609 (Clear Lens) JANTX1N6609 (Clear Lens), and Panel Mount Assembly, Types JANM19500/51901, JANTXM19500/51902, JANM19500/51903 (Clear Lens), and JANTXM19500/51904 (Clear Lens)
- MIL-PRF-19500/572 - Semiconductor Device, Diode, Light Emitting, Types 1N6493, 1N6494, 1N6495, 1N6500, 1N6501, and 1N6502, JAN and JANTX
- MIL-PRF-19500/708 - Displays, Diode, Light Emitting, Solid State, Red, Numeric and Hexadecimal, With on Board Decoder/Driver Types 4N51, 4N52, 4N53, 4N54 JAN and JANTX
- MIL-R-19523 - Relays, Control

DEPARTMENT OF DEFENSE STANDARDS

- MIL-STD-108 - Definitions of and Basic Requirements for Enclosures for Electric and Electronic Equipment
- MIL-STD-167-1 - Test Method Standard for Mechanical Vibrations of Shipboard Equipment (Type I-Environmental and Type II-Internally Excited)
- MIL-STD-202 - Test Method Standard for Electronic and Electrical Component Parts
- MIL-STD-461 - Interface Standard for Requirements for the Control of Electromagnetic Interference Characteristics of Subsystems and Equipment
- MIL-STD-681 - Standard Practice for Identification Coding and Application of Hookup and Lead Wire
- MIL-STD-740-2 - Structureborne Vibratory Acceleration Measurements and Acceptance Criteria of Shipboard Equipment
- MIL-STD-810 - Test Method Standard for Environmental Engineering Considerations and Laboratory Tests
- MIL-STD-1310 - Standard Practice for Shipboard Bonding, Grounding, and Other Techniques for Electromagnetic Compatibility, Electromagnetic Pulse (EMP) Mitigation, and Safety
- DOD-STD-1399-070-1 - Interface Standard for Shipboard Systems, Section 070 - Part 1, D.C. Magnetic Field Environment (Metric)
- MIL-STD-1399-300 - Interface Standard for Shipboard Systems, Section 300B, Electric Power, Alternating Current
- MIL-STD-1472 - Human Engineering
- MIL-STD-1474 - Design Criteria Standard for Noise Limits
- MIL-STD-1686 - Standard Practice for Electrostatic Discharge Control Program for Protection of Electrical and Electronic Parts, Assemblies and Equipment (Excluding Electrically Initiated Explosive Devices)

(Copies of these documents are available online at <http://quicksearch.dla.mil/> or <https://assist.dla.mil/>.)

MIL-PRF-32150B

2.3 Non-Government publications. The following documents form a part of this document to the extent specified herein. Unless otherwise specified, the issues of these documents are those cited in the solicitation or contract.

INSTITUTE OF ELECTRICAL AND ELECTRONICS ENGINEERS, INC. (IEEE)

IEEE 1012 - Standard for Software Verification and Validation

IEEE 1394 - Standard for a High Performance Serial Bus

(Copies of these documents are available online at www.ieee.org or from the Institute of Electrical and Electronics Engineers, Inc., 445 Hoes Lane, P.O. Box 1331, Piscataway, NJ 08855-1331.)

NATIONAL INSTITUTE OF STANDARDS AND TECHNOLOGY (NIST)

NIST SP 500-234 - Reference Information for the Software Verification and Validation Process

(Copies of this document are available online at <http://www.nist.gov/nvl/> or from the NIST Standards Information Center, 100 Bureau Drive, Stop 2100, Gaithersburg, MD 20899-2100.)

UNDERWRITERS LABORATORIES, INC. (UL)

UL 1008 - Standard for Transfer Switch Equipment

(Copies of this document are available online at www.ul.com or from Underwriters Laboratories, Inc., 333 Pflugsten Road, Northbrook, IL 60062-2096.)

2.4 Order of precedence. Unless otherwise noted herein or in the contract, in the event of a conflict between the text of this document and the references cited herein, the text of this document takes precedence. Nothing in this document, however, supersedes applicable laws and regulations unless a specific exemption has been obtained.

3. REQUIREMENTS

3.1 Qualification. SABTs furnished under this specification shall be products that are authorized by the qualifying activity for listing on the applicable qualified products list before contract award (see 4.2 and 6.3).

3.2 Materials. The contractor shall select materials capable of meeting all of the operational and environmental requirements specified herein in accordance with MIL-E-917.

3.2.1 Recycled, recovered, or environmentally preferable materials. Recycled, recovered, or environmentally preferable materials should be used to the maximum extent possible provided that the material meets or exceeds the operational and maintenance requirements, and promotes economically advantageous life cycle costs.

3.2.2 Electrical insulation. Electrical insulating materials shall be in accordance with the requirements of MIL-DTL-16036.

3.2.3 Parts. Parts used in SABTs shall be in accordance with the requirements of MIL-E-917 when available.

3.2.4 Indicator lights, lamps, LEDs, and lenses. Alternating current (AC) indicator lights shall conform to style LH98 for AC service in accordance with MIL-L-3661/65. Direct current (DC) indicator lights shall conform to style LH96 for DC service in accordance with MIL-L-3661/63. Light emitting diodes (LEDs) shall be in accordance with the requirements of MIL-PRF-19500/519, MIL-PRF-19500/572, or MIL-PRF-19500/708. For position indication of a circuit breaker, blue indicator lights shall be used to show that the circuit breaker is closed. Indicator lights have color lenses style LC40 in accordance with MIL-L-3661/54 with the color code specified in accordance with MIL-STD-1472.

MIL-PRF-32150B

3.2.5 Serial connection. If the SABT has embedded software (firmware) that is capable of being communicated by external means, then communications shall be by an RS-232, USB2.0, or firewire IEEE 1394 (or similar, if supported by industry standards) port for a remote computer for the purpose of controlling the SABT electrical parameters and to allow programming of setpoints. A software program shall be provided to interface with the SABT for the purpose of establishing these parameters and setpoints during shipboard installation. No infrared or radio frequency (RF) communications are allowed.

3.2.6 Relays. If electro-mechanical relays are used, they shall be in accordance with the requirements of MIL-R-19523.

3.2.7 Creepage and clearance distances. Electrical creepage and clearance distances shall be in accordance with MIL-E-917.

3.2.8 Nameplates. Manufacturer identification, other than that allowed for the nameplates, shall not appear on the equipment. Markings shall be in accordance with MIL-DTL-15024 and MIL-P-15024/5.

3.2.8.1 Embedded software. Embedded software or firmware that is used in SABTs shall appear on the nameplate by name, part number, the version number, or designator. Equipment furnished with embedded software and calibration software shall have software certified by independent verification and validation (V&V) testing to NIST SP 500-234 and IEEE 1012 standards or provide an acceptable alternative for approval.

3.2.9 Bus bar plating. SABT bus bars shall be made to provide adequate corrosion protection in the marine environment with an expected life of 50 years and shall not degrade the electrical conductivity below that of bare copper.

3.2.10 Cable entrance. Cable entrance shall be in accordance with the requirements of MIL-E-2036.

3.2.11 Wire, wiring methods, and marking. Wire, wiring methods, and marking shall be in accordance with the requirements of MIL-E-917. Color-coded wire may be used in accordance with MIL-STD-681.

3.2.12 Terminal markings for supply lines and loads. Terminal markings for supply lines and loads of SABTs shall be in accordance with [table I](#). Like phases shall be arranged in the same manner. The phase rotation shall be A, B, C, respectively, from right to left (facing the front), top to bottom, and front to back.

TABLE I. Terminal markings.

Sources and load	AC
Normal (N) source	SA, SB, SC
Emergency (E) source	EA, EB, EC
Load	L1, L2, L3
Normal (N) source	S1A, S1B, S1C
Alternate (A) source	S2A, S2B, S2C
Load	L1, L2, L3

3.2.13 Diagrams. Each SABT switch shall include a wiring diagram and a schematic diagram. The information shall be protected in accordance with Method 1 of MIL-E-2036 and shall be attached to the inside of the enclosure door in accordance with MIL-E-2036. Wiring diagrams shall include wire numbers, component identification, and fuse size and type, if applicable.

3.2.14 Instruction sheets. When specified (see 6.2), instruction sheets for installation shall be in accordance with MIL-E-2036.

3.2.15 Configuration settings. When specified (see 6.2), SABTs with adjustable settings shall include those settings affixed in or on the SABT in accordance with MIL-DTL-15024 and MIL-P-15024/5.

MIL-PRF-32150B

3.2.16 Paint. Paint used on the SABTs shall be in accordance with the requirements of MIL-E-917. Color shall be No. 26307 as specified by FED-STD-595.

3.3 Weight and size. Unless otherwise specified (see 6.2), the SABT shall weigh not more than 350 pounds and shall be not more than 40 inches high by 30 inches wide by 20 inches deep.

3.4 Performance characteristics.

3.4.1 Special features. When applicable, special features shall be as specified (see 6.2).

3.4.2 Operation. The SABT shall be designed to operate automatically, manually, and in automatic test.

3.4.2.1 Automatic. The SABT shall monitor the power supplied from both the normal power source and the alternate power source (see 6.4.25). A source shall be considered “available”:

a. When the source is within preset levels, or

b. When the source is not within preset levels, the SABT shall transfer (see 6.4.27) to the alternate source provided the alternate source is available (see 6.4.2). The SABT shall provide two automatic transfers: in-phase transfer and random transfer as specified in [table II](#). The SABT shall allow for operation with a preferred source (see 6.4.20), in which case the unit shall preferentially power the load from that source, provided it is available. This is called Normal Seeking (see 6.4.11). However, when the SABT is Power Seeking (see 6.4.19), it shall re-transfer (see 6.4.22) to the initially active source (see 6.4.1) following restoration of the initially active source to an available status, only if the presently active source becomes unavailable.

TABLE II. Transfer threshold setting.

Set Points	120 V SABT	208 V SABT	450 V SABT
In-Phase Transfer Voltage	96 V – 102 V	166 V – 177 V	358 V – 383 V
Random Transfer Voltage	72 V – 84 V	124 V – 146 V	271 V – 317 V

3.4.2.1.1 In-phase transfer. The SABT shall have a programmable in-phase transfer voltage (see 6.4.9) setpoint (see [table II](#)), which shall be higher than the transfer voltage setpoint. Upon the voltage of the normal power source dropping to the in-phase voltage setpoint, the unit shall initiate a transfer provided the alternate power source is available and both sources are within the phase angle difference setting (see 3.4.36). If the re-transfer feature is enabled (see 3.4.3.7), and the initially active source was the normal source (see 6.4.12), an automatic re-transfer may occur only if allowed by in-phase monitoring (see 3.4.36) following restoration of the normal source to an available status.

3.4.2.1.2 Random transfer. Provided the alternate source is available, the SABT shall initiate a transfer when the normal source voltage falls below the random transfer setpoint setting. If the re-transfer feature is enabled (see 3.4.3.7), and the initially active source was the normal source, an automatic re-transfer may occur only if allowed by in-phase monitoring (see 3.4.36) following restoration of the normal source to an available status. 60 Hz SABTs shall have the capability to dynamically limit in-rush current for out-of-phase transfers to prevent tripping of upstream circuit breakers.

3.4.2.2 Manual. To ensure fail-safe operation, the SABT shall have a manual selection for transferring power sources. During the manual operation, the SABT automatic functions shall be disabled. Manual transfer shall be initiated by activating a switch or button on the front panel. A manual transfer can occur without the SABT checking the quality of the primary and alternate power sources. Once initiated, a manual transfer shall force the SABT to transfer from the normal source to the alternate source (or vice versa).

3.4.2.2.1 Manual control circuit isolation. The manual operation shall be capable of functioning independently of the SABT control circuitry and shall be capable of initiating a transfer in the event of a power loss or other failure to the SABT control circuitry as long as either the normal or alternate power source is energized. The control circuitry is that circuitry which affects the successful automatic transfer from one power source to the other. The SABT shall also have the ability to transfer back to automatic.

MIL-PRF-32150B

3.4.2.3 Transfer test. The SABB shall include a transfer test. The test shall simulate a loss of power to verify that the SABB transfers power to the other source.

3.4.3 Operational features.

3.4.3.1 Selector switch. SABBs shall be provided with a selector switch that controls manual or automatic SABB operation (see 6.4.24).

3.4.3.2 Preferred source selector switch and control circuit. Two-way SABBs with normal (ship's service) and alternate (ship's service) supply sources shall be provided with a preferred source selector switch that controls the selection of the preferred source of power.

3.4.3.3 Operating voltages. The SABB shall operate with tolerances in accordance with MIL-STD-1399-300 as specified (see 1.2.1 and 6.2).

3.4.3.4 Transfer threshold voltage settings. Setpoint voltage shall be adjustable (see [table II](#)).

3.4.3.5 Pickup voltage. Pickup voltage (see 6.4.18) shall be adjustable from 85 to 95 percent.

3.4.3.6 Instantaneous transfer. On types requiring instantaneous transfer, the transfer time shall be $\frac{1}{4}$ to $\frac{1}{2}$ cycles.

3.4.3.7 Transfer stabilization time (see 6.4.26). Re-transfer shall be adjustable to inhibit transfer (see 6.4.7) from 0 to 10 seconds to allow for source stabilization.

3.4.3.8 Operating frequency. The SABB shall operate in accordance with MIL-STD-1399-300. For frequency and configuration Type CT21 and CT23, unless otherwise specified (see 6.2), transfer shall be initiated when the frequency drops 2 to 3 Hz below rated.

3.4.3.9 Full phase protection. Unless otherwise specified (see 6.2), full phase protection (see 6.4.5) shall be provided (see 1.2.3). Operating voltages shall be in accordance with 1.2.1.

3.4.3.10 Self-diagnostics. The SABB shall incorporate self-fault diagnostics to the printed circuit board level. If a failure should occur, a summary indicator shall be shown on the front panel and an audible alarm shall sound. If a solid-state power conduction component either on the conducting or non-conducting side fails, the SABB shall automatically transfer power to that side to minimize source-to-source leakage current. Redundant power supplies may be used to improve fault tolerance and reliability.

3.4.4 Maintainability. The maintainability capability provided for the unit when combined in a target system platform shall make it possible for the assigned maintenance personnel to perform necessary unit equipment repairs at the organizational level within the mean time to repair (MTTR) criteria specified herein. The MTTR shall not exceed 30 minutes. The maximum time to repair (M_{max}) at the 95th percentile shall not exceed 60 minutes. Time to repair shall be the sum of the time required for:

- a. Fault localization (including diagnostic execution time)
- b. Fault isolation
- c. Disassembly
- d. Interchange/repair
- e. Reassembly
- f. Setpoint adjustment
- g. Repair validation
- h. Replacing fans and filters.

3.4.5 Performance monitoring (PM). PM shall be provided to support operation and maintenance. PM shall be capable of monitoring the normal operation of the SABB for the purpose of detecting and reporting errors. This shall also apply to stand-by hardware elements.

MIL-PRF-32150B

3.4.5.1 PM detection and reporting. PM shall be designed such that faults can be detected and isolated using a recommended fault localization test. PM shall also be designed such that 95 percent of all operational faults or processing errors and failures that occur over time shall be detected and reported.

3.4.5.2 False PM alerts. At least 98 percent of all PM test results shall be free of false alerts.

3.4.6 Fault localization (FL). An FL capability shall be provided to localize SABT hardware faults and failures.

3.4.6.1 FL detection and reporting. FL shall be designed such that faults detected in the hardware are isolated to the module.

3.4.6.2 False FL indications. At least 99 percent of all FL test results shall be free of false alerts. An FL false alert is an FL failure detection that cannot be associated with an actual hardware failure.

3.4.7 Control panel. The SABT control panel shall provide the operator with the controls and indicators necessary to monitor the status of the normal and alternate power sources. All SABT controls and indications shall be located on the front of the unit. Indication of phase angle detection may be instrumented with a blinking amber indicator. Out of phase condition shall not be labeled as an error condition. Mimic panels may be used to indicate status.

3.4.7.1 Indicator and audible alarm. The SABT control panel shall use a series of indicators to provide operational status of the unit in accordance MIL-STD-1472. Indicators shall identify the status of power to the loads, the status of each power source, automatic or manual, the presence of an internal logic fault, and identification of the preferred power source. If air-cooled, a method to indicate partial or complete loss of cooling air shall also be provided. A display shall be provided to act as a counter for the number of load transfers performed by the unit, as well as to provide indications in the event of an SABT fault. Phase angle differences greater than the preset value between the two input power sources, if monitored, shall be displayed. Additionally, an audible alarm shall sound when a fault is detected. This alarm:

- a. Shall act in concert with visual indicators that will allow the operator to identify the fault.
- b. Shall not latch as a result of a temporary fault that immediately clears with no operator action.
- c. When acknowledged, shall stop sounding but the visual alarm shall remain if the fault does not clear.
- d. Shall be such that the audible feature can be preemptively disabled, in which case the fault shall still be indicated via visual clues as discussed in 3.4.7.1a above.

3.4.7.2 Controls.

3.4.7.2.1 Indicator test switch. The SABT shall provide a switch for the purpose of indicator testing. Depressing the switch will cause all indicators to light for a short time without disruption to the load.

3.4.7.2.2 Automatic or manual selector switch. The SABT shall provide a selector switch for the purpose of choosing manual or automatic. If the switch is in manual position, the automatic functions are disabled. If the switch is in automatic position, the automatic functions are enabled.

3.4.7.2.3 Control enable switch. The SABT shall provide a control enable switch for the purpose of enabling the manual operator switch, the transfer test switch, and the fault reset switch. This switch, as well as the manual operator switch, transfer test switch, and fault-reset switch, shall be of the momentary action type.

3.4.7.2.4 Manual operator switch. The SABT shall provide a manual operator switch for the purpose of transferring power sources in manual. The control enable switch shall be depressed to enable the manual operator switch.

3.4.7.2.5 Transfer test switch. The SABT shall provide a transfer test switch for the purpose of initiating a transfer test. The control enable switch shall be depressed to enable the transfer test switch.

MIL-PRF-32150B

3.4.7.2.6 Fault reset switch. The SABT shall provide a switch for the purpose of resetting faults. This switch will not be able to reset any fault whose presence would correctly inhibit a shift. (Example: a condition whereby the alternate source is below the minimum acceptable voltage). The control enable switch shall be depressed to enable the fault-reset switch.

3.4.7.2.7 Graphical user interface (GUI). 3.4.7.2.1 through 3.4.7.2.6 can also be performed using a GUI.

3.4.8 Fusing of control circuits and indicator circuits. SABTs shall not have fused control circuits (see 6.4.4) and indicator circuits (see 6.4.6).

3.4.9 General fusing. If fusing is used in the SABT, it shall have external blown-fuse indicators in accordance with MIL-PRF-19207.

3.4.10 Manual bypass mechanism. A manual bypass mechanism for the SABT shall be located in a readily accessible location. It shall be capable of selecting available sources of power without any interface with the SABT electronic control circuitry. A manual bypass mechanism shall have a mechanical position indicator to identify selected source.

3.4.11 Auxiliary switches. When specified (see 6.2), SABTs shall be provided with an auxiliary switch for remote indication of the supply line connected to the load circuit or for a function limiting device, or both. The auxiliary switch contacts shall be wired to a terminal board in the SABT for connection to the remote equipment. Auxiliary switches shall have a minimum rated continuous current of 5 amps and a rated voltage of 500 VAC and 250 VDC and meet the endurance requirements as specified in [table VII](#).

3.4.12 External control cable connections. When specified (see 6.2), terminal boards or studs shall be provided for external control connections. Terminal boards and studs shall be accessible from the front of the enclosure with the front panel open, and the control wire connection points shall be identified.

3.4.13 Grounding. Grounding shall be in accordance with MIL-STD-1310.

3.4.13.1 Chassis grounding. All external parts capable of electrical conduction shall be at ground potential at all times in accordance with MIL-STD-1310. Each chassis within the enclosure shall be electrically bonded to minimize electromagnetic interference (EMI). The DC resistance measured from the conductive frame of any assembly receiving primary power and the unit electrical bond point shall not exceed 0.1 ohm.

3.4.13.2 Line-to-ground impedance. The insulation resistance or impedance to ground shall be measured with all operating components attached and connected in the SABT's normal operational condition with no internal wiring disconnected. Insulation resistance of SABTs shall be not less than 10 megohms as specified in MIL-E-917.

3.4.13.3 Operational source-to-source impedance. The source-to-source impedance, an inherent characteristic of the semiconductor switch circuit, shall be not less than 1.3 megohms at 68 °F (20 °C) with a minimum load of 25 amps and 0.5 megohm at 122 °F (50 °C). If specified (see 6.2), a higher source-to-source impedance may be required.

3.4.14 Electrostatic discharge (ESD) protection requirements. The use of ESD sensitive components is discouraged. When specific parts, modules, connectors/receptacles, or subassemblies sensitive to damage by ESD are used, the devices shall be clearly marked with ESD labeling in accordance with MIL-STD-1686. The symbol shall be located in a position readily visible to personnel when that assembly is incorporated into its next higher assembly.

3.4.15 System grounding. SABTs shall operate in ungrounded circuits and high resistance grounded circuits as specified (see 6.2).

3.4.16 Duty. SABTs shall operate continuous duty (see 6.4.3).

3.4.17 Electromagnetic interference (EMI). When specified (see 6.2), all enclosures shall employ EMI door gaskets and shielding of control and indicator openings to provide EMI shielding of the enclosed electronics in accordance with MIL-STD-461.

MIL-PRF-32150B

3.4.18 Conducted emissions. The SABT shall not exceed the CE101 and CE102 limits of MIL-STD-461. Additionally, the upper limit of CE101 shall be extended to 20 KHz.

3.4.19 Conducted susceptibility. The SABT shall be in accordance with the specified performance requirements per the CS101, CS114, and CS116 limits of MIL-STD-461.

3.4.20 Conducted susceptibility spikes, power leads. The SABT shall not exhibit any malfunction, degradation of performance, or deviation from specified indications when tested in accordance with 4.6.7.

3.4.21 Radiated emissions, AC magnetic field. The SABT shall not exceed the RE101 limits of MIL-STD-461.

3.4.22 Radiated emissions, AC electric field. The SABT shall not exceed the RE102 limits of MIL-STD-461.

3.4.23 Radiated susceptibility, AC magnetic field. The SABT shall be in accordance with the specified performance requirements in an AC magnetic field per the RS101 limits of MIL-STD-461.

3.4.24 Radiated susceptibility, DC magnetic field. The SABT shall be compatible with the magnetic field environment interface constraints of DOD-STD-1399-070-1.

3.4.25 Radiated susceptibility, AC electric field. The SABT shall be in accordance with the specified performance requirements in an electric field per the RS103 limits of MIL-STD-461.

3.4.26 Radiated susceptibility, magnetic and electric fields, spikes and power frequencies. The SABT shall not exhibit any malfunction, degradation of performance, or deviation from specified indications when tested in accordance with MIL-STD-461 and 4.6.13.

3.4.27 Power. The SABT shall operate in accordance with MIL-STD-1399-300 and shall not introduce negative electrical characteristics to exceed the values specified therein during steady-state operation and during transfer. The SABT shall not introduce transients or noise in excess of that defined and allowed by MIL-STD-1399-300.

3.4.28 Safety. The SABT shall operate in a safe manner such that two procedural errors, or the malfunction of any single hardware or software component or element, shall not result in catastrophic hazards, causing death, system loss, or severe environmental damage, or critical hazards, causing severe injury, severe occupational illness, or major system or environmental damage. Safety requirements for the equipment shall be in accordance with MIL-E-917.

3.4.29 Personnel electrical safety.

3.4.29.1 High voltage protection. Protection from dangerous voltages (30 to 500 Vrms or 30 to 500 VDC) shall be provided by the use of guards, grounding, and warning placards in accordance with MIL-E-917. Assemblies operating at potentials exceeding 500 Vrms or 500 VDC shall be completely enclosed. The maximum discharge time shall be 10 seconds to discharge components or assemblies from their operating voltages to 30 Vrms or less.

3.4.29.2 High current protection. Protection from shock hazards that can occur from contact with current producing circuitry of 21 mA AC or 80 mA DC at a potential of greater than 30 VDC or 30 Vrms shall be provided. For high current (greater than or equal to 25 amps) power sources, positive design measure shall be incorporated by the use of guards, barriers, and warning placards.

3.4.29.3 Chassis leakage current protection. All electrical parts capable of electrical conduction shall be at ground potential in accordance with MIL-STD-1310 and shall limit leakage current for personnel safety in accordance with MIL-STD-1399-300.

3.4.29.4 Source-to-source leakage current for maintenance. Unless otherwise specified (see 6.2), leakage current to the non-energized side of the SABT shall be controlled by air gap isolation between sources to allow for safe load center maintenance.

3.4.30 Electrical bonding. Electrical bonding shall be in accordance with MIL-STD-1310.

MIL-PRF-32150B

3.4.31 Mechanical hazards. Suitable protection shall be provided to prevent contact with moving mechanical parts such as gears, fans, and belts when the equipment is operating. Sharp projections on cabinets, doors, and similar parts shall be avoided. Rack-mounted equipment shall maintain the center of gravity as low as possible to minimize tipping over. Door or hinged covers shall be rounded at the corners, provided with stops to hold them open, and shall be removable. SABB design shall include provisions to prevent accidental pulling out of drawers or rack-mounted equipment components, which would cause equipment damage or injury. Equipment power switches, if used, shall be located so that accidental contact shall not place the equipment in operation, secure the equipment, or change its operation.

3.4.32 Component heat removal. If forced air-cooling is used, the unit shall generate no more than the structureborne or airborne noise acceptance criteria as specified in MIL-STD-740-2. A complete or partial loss of cooling air shall be indicated prior to the unit overheating or an over temperature alarm being reached. The unit shall be capable of operating normally for a period of at least 24 hours at rated load, in 122 °F (50 °C) ambient air, with a loss of one-third, minimum, of the active cooling capacity, and support the rated load for a minimum of 6 hours, in 82 °F (28 °C) ambient air, with a loss of all (100 percent) of the active cooling capacity.

3.4.33 Transfer positions. SABBs shall be two-way.

3.4.34 Line voltages. Line voltages shall be in accordance with MIL-STD-1399-300.

3.4.35 Line phases. SABBs shall operate in three-phase circuits.

3.4.36 Phase angle difference. The SABB shall have an adjustable phase angle difference feature (see 6.4.17) range of 1.0 to 60 degrees. The phase angle difference is the largest phase difference at which an in-phase transfer is still allowed. An indication shall be displayed by an amber indicator when the phase angle difference is greater than the allowable setting.

3.4.37 In-phase transfer voltage. The SABB shall have an adjustable in-phase transfer voltage range from 80 to 85 percent rated voltage.

3.4.38 Random transfer voltage. The SABB shall have an adjustable random transfer voltage (see 6.4.21) range from 60 to 70 percent rated voltage.

3.4.39 Over-frequency setpoint (CT21 and CT23). Unless otherwise specified (see 6.2), the SABB shall have an adjustable over-frequency setpoint (see 6.4.15) range from 103 to 108 percent operating frequency.

3.4.40 Over-frequency pickup (CT21 and CT23). Unless otherwise specified (see 6.2), the SABB shall have an adjustable over-frequency pickup (see 6.4.14) range from 100 to 105 percent operating frequency.

3.4.41 Under-frequency setpoint (CT21 and CT23). Unless otherwise specified (see 6.2), the SABB shall have an adjustable under-frequency setpoint range from 83 to 95 percent operating frequency. When the active source frequency falls below the under-frequency setpoint, and the frequency trips are enabled, the unit shall transfer to the inactive source, provided this source is available.

3.4.42 Under-frequency pickup (CT21 and CT23). Unless otherwise specified (see 6.2), the SABB shall have an adjustable under-frequency pickup range from 95 to 100 percent operating frequency.

3.4.43 Compatibility with active ground fault detector circuit. When specified (see 6.2), an SABB connected to both power sources and to the loads shall:

- a. Have a source-to-source impedance as high as possible, but not less than 0.5 megohm at 122 °F (50 °C).
- b. Have a minimum source-to-ground impedance of at least 10 megohms.
- c. Not cause a low-impedance to ground fault condition detected on one source to be imposed on, transferred to, or reflected on the other source.

3.4.44 Endurance and overload. Unless otherwise specified (see 6.2), SABBs and SABB auxiliary switches shall be in accordance with the endurance and overload requirements when tested in accordance with 4.6.17 and [table VII](#).

MIL-PRF-32150B

3.4.45 Short-circuit withstandability. Unless otherwise specified (see 6.2), SABTs shall be in accordance with the short-circuit withstandability (see 6.4.26) requirements specified in [table III](#).

TABLE III. SABT short-circuit withstandability.

Continuous rating (A)	Short-circuit current (A) at pf 0.15-0.20		Duration (seconds)	
	60 Hz	400 Hz	60 Hz	400 Hz
To 50	10000	10000	0.017	0.021
51 to 100	15000	10000	0.017	0.021
101 to 250	20000	10000	0.025	0.028
251 to 400	30000	10000	0.028	0.033

3.4.46 Dielectric withstanding voltage. SABTs shall be in accordance with the dielectric withstanding voltage requirements when tested in accordance with MIL-E-917.

3.4.47 Enclosures. Enclosures for the SABT shall be drip-proof, watertight, or splash-proof, as specified (see 6.2) and shall be in accordance with the performance requirements of MIL-E-2036 for Class I enclosures for electronic equipment.

3.4.48 Remote monitoring and control. When specified (see 6.2), SABTs shall have the capability for personnel to monitor and control the operation remotely. Remote interface cables shall enter the top or bottom of the enclosure. Communications shall be facilitated using an industry standard port such as RS485, Profibus, or Ethernet.

3.5 Environmental conditions.

3.5.1 Ambient temperature. The SABT shall operate over an ambient temperature range of 32 to 122 °F (0 to 50 °C) in accordance with MIL-E-917.

3.5.2 Humidity. The SABT shall operate satisfactorily during and subsequent to exposures to relative humidities ranging up to 95 percent for both continuous and intermittent periods, including conditions wherein condensation occurs on the equipment.

3.5.3 Pressure. The SABT shall operate within performance limits of MIL-STD-202 while subjected to an atmospheric pressure from 24 to 36 inches of mercury.

3.5.4 Temperature rise. The SABT shall operate in an ambient temperature as specified in MIL-DTL-16036.

3.5.5 Inclined operation. SABTs shall be in accordance with the requirements for inclined operation as specified in MIL-E-917.

3.5.6 Shock. SABTs shall be in accordance with Grade A, Class I, Type A high impact shock tests as specified in MIL-S-901.

3.5.7 Vibration. SABTs shall be in accordance with Type I vibration tests specified in MIL-STD-167-1.

3.5.8 Protection against arcs. The interior of enclosing cases shall be protected by insulating material selected in accordance with the requirements of MIL-E-917.

3.5.9 Airborne noise. When specified (see 6.2), airborne noise requirements shall be in accordance with MIL-STD-1474.

3.5.10 Structureborne noise. When specified (see 6.2), structureborne noise requirements shall be in accordance with MIL-STD-740-2.

MIL-PRF-32150B

4. VERIFICATION

4.1 Classification of inspections. The inspection requirements specified herein are classified as follows:

- a. Qualification inspection (see 4.2).
- b. Conformance inspection (see 4.3).

4.2 Qualification inspection. Qualification inspection shall be performed on one complete SABT of each rating and shall include the examinations and tests specified in [table IV](#). Qualification tests shall be conducted at a laboratory deemed acceptable by the Naval Sea Systems Command (NAVSEA).

4.2.1 Periodic retention of qualification. At intervals of not more than 4 years after initial qualification, inspection for retention of qualification shall be performed on SABTs of a given design and shall include the tests specified in [table V](#), in the order listed.

4.2.2 Change approval. A change in material, production processes, or production equipment used in the manufacture of SABTs, which have been qualified, shall require written approval of NAVSEA. Incorporation of any changes, which have not been so approved, shall require requalification of item in question.

4.2.3 Failure. Failure of any sample to meet the requirements specified herein shall be cause for disapproval of or removal of product qualification.

4.3 Conformance inspection. Conformance inspection shall be performed to verify that the SABT meets specification requirements prior to acceptance and shall include the tests specified in [table IV](#).

4.4 Inspection conditions. All inspections shall be performed in accordance with the test conditions specified in the general requirements of MIL-STD-202.

TABLE IV. Qualification tests and conformance inspections.

Tests	Requirement	Qualification Test	Conformance Inspection
Examination	3.2 – 3.3, 3.4.5 – 3.4.13.2, 3.4.28, 3.4.29.1, 3.4.29.2, 3.4.30 – 3.4.42	4.5	4.5
Operational	3.4.2 – 3.4.3.10	4.6.1.2 – 4.6.1.11	4.6.1.2 – 4.6.1.11
Order of Precedence	4.6.1.1	4.6.1.1	4.6.1.1
Line-to-Ground Impedance	3.4.13.2	4.6.2	--
Operational Source-to-Source Impedance	3.4.13.3	4.6.3	--
EMI	3.4.17	4.6.4	--
Conducted Emissions	3.4.18	4.6.5	--
Conducted Susceptibility	3.4.19	4.6.6	--
Conducted Susceptibility Spikes, Power Leads	3.4.20	4.6.7	--
Radiated Emissions, AC Magnetic Field	3.4.21	4.6.8	--
Radiated Emissions, AC Electric Field	3.4.22	4.6.9	--

MIL-PRF-32150B

TABLE IV. Qualification tests and conformance inspections – Continued.

Tests	Requirement	Qualification Test	Conformance Inspection
Radiated Susceptibility, AC Magnetic Field	3.4.23	4.6.10	--
Radiated Susceptibility, DC Magnetic Field	3.4.24	4.6.11	--
Radiated Susceptibility, AC Electric Field	3.4.25	4.6.12	--
Radiated Susceptibility, Magnetic and Electric Fields, Spikes and Power Frequencies	3.4.26	4.6.13	--
Power	3.4.27	4.6.14	--
Chassis Leakage Current Protection	3.4.29.3	4.6.15	--
Compatibility with Active Ground Fault Detector Circuit	3.4.43	4.6.16	--
Endurance and Overload	3.4.44	4.6.17	--
Short-Circuit Withstandability	3.4.45	4.6.18	--
Dielectric Withstanding Voltage	3.4.46	4.6.19	--
Degree of Enclosure	3.4.47	4.6.20	--
Remote Monitoring and Control	3.4.48	4.6.21	--
Ambient Temperature	3.5.1	4.6.22	--
Humidity	3.5.2	4.6.23	--
Pressure	3.5.3	4.6.24	--
Temperature Rise	3.5.4	4.6.25	--
Inclined Operation	3.5.5	4.6.26	--
Shock	3.5.6	4.6.27	--
Vibration	3.5.7	4.6.28	--
Airborne Noise	3.5.9	4.6.29	--
Structureborne Noise	3.5.10	4.6.30	--

MIL-PRF-32150B

TABLE V. Periodic tests.

Tests	Requirement Paragraph	Test Paragraph
General examination	3.2 – 3.3, 3.4.5 – 3.4.13.2, 3.4.28, 3.4.29.1, 3.4.29.2, 3.4.30 – 3.4.42	4.5
Effectiveness of enclosure	3.4.47	4.6.20
General operation	3.4.2 – 3.4.3.10	4.6.1.2 – 4.6.1.11
Endurance and overload	3.4.44	4.6.17
Shock	3.5.6	4.6.27
Vibration	3.5.7	4.6.28
Insulation resistance	3.4.13.2	4.6.2
Dielectric withstanding voltage	3.4.46	4.6.19

4.5 Examination. Each SABB shall be examined for compliance with the requirements specified in [table IV](#). This element of inspection shall encompass all visual examinations and dimensional measurements. The examination shall be conducted using the classifications of defects as specified in [table VI](#), as applicable. Noncompliance with any specified requirements or presence of one or more defects preventing or lessening maximum efficiency shall constitute cause for rejection.

TABLE VI. Classification of defects.

Category	Defect	Related Requirement
001	Prohibited materials are used.	3.2
002	Insulating material not as specified or not provided as required.	3.2.2
003	Supply line and load terminal markings not as specified.	3.2.12
004	Manual operation for SABB switch not provided as required.	3.4.2.2
005	Preferred source selector switch not provided as specified.	3.4.3.2
006	Full phase protection not provided as specified.	3.4.3.9
007	Power available indicator not provided for manual bus transfers.	3.4.7.1
008	Test switch not provided for SABB switches.	3.4.7.2.5
009	Fusing of control circuits and indicator circuits not as specified.	3.4.8
010	General fusing not as specified.	3.4.9
011	Manual bypass mechanism not external to the enclosure or located in a readily accessible position and manual operating mechanism does not have mechanical position indicator for supply line indication.	3.4.10
012	Transfer positions are not two-way as specified.	3.4.33
013	Number of line phases not as specified for SABBs.	3.4.35
101	Parts not in conformance with applicable specifications.	3.2.3 and 3.5.8
102	Indicator lights, LEDs not as specified.	3.2.4
103	Relays not as specified.	3.2.6

MIL-PRF-32150B

TABLE VI. Classification of defects – Continued.

Category	Category	Category
104	Information plates, identification plates, and marking not as specified.	3.2.8
105	Cable entrances not as specified.	3.2.10
106	Wire, wiring methods, and marking not as specified.	3.2.11
107	Diagrams and descriptions of operation not provided as specified.	3.2.13
108	Auxiliary switches not as specified.	3.4.11
109	Terminal boards not provided or wire connection points not accessible and identifiable.	3.4.12
110	Degree of enclosure not as specified.	3.4.47
201	Creepage and clearance distances not as specified.	3.2.7
202	Painting not as specified.	3.2.16

4.6 Methods of inspection.4.6.1 Operational tests.

4.6.1.1 Order of precedence. The following tests shall be completed in the following order and a successful completion of each individual test is required to continue to the following test:

- a. Shock (see 4.6.27)
- b. Vibration (see 4.6.28)
- c. Short circuit withstandability (see 4.6.18)
- d. Dielectric withstandability (see 4.6.19)

4.6.1.2 Automatic operation. SABTs shall be operated to determine that the operating voltages are as specified in 3.4.3.3. Not less than five transfers and five re-transfers shall be made under conditions of constant temperature, frequency, and rate of change of voltage. Testing shall also be performed using asynchronous sources at worst case scenario of 180 degrees out of phase (does not apply to 400 Hz SABTs).

4.6.1.3 Manual operation. When manual has been selected (see 3.4.2.2), automatic control circuit devices shall not be operable while the manual-automatic selector switch is in the manual position; the SABTs shall not automatically transfer.

4.6.1.4 Preferred source selection. The preferred source selector switch shall be switched to each position and the SABTs shall be operated to determine that the actual preferred source is as selected.

4.6.1.5 Transfer timing. Operating transfer time (see 6.4.13) as specified by the SABT configuration type (see 1.2.3), shall be measured five times. The voltage shall be reduced quickly to approximately five equal intervals. The SABT shall pick up the non-preferred source within ¼ to ½ cycles.

4.6.1.6 Test switch. The SABT's test switch shall be operated to determine that it simulates a voltage failure and a transfer action occurs.

4.6.1.7 Full phase protection. When specified (see 6.2), the SABTs shall be operated to determine the operating voltage of each phase. Not less than five transfers and five re-transfers per phase voltage test shall be made under conditions of constant temperature, frequency, and rate of change of voltage.

4.6.1.8 In-phase monitoring (not applicable to 400 Hz). The frequency of the two sources shall be at 60 Hz. SABTs shall be operated in each direction of transfer by changing the voltage levels of the normal source. Phase angle difference between sources shall be varied during testing to demonstrate the in-phase monitoring capability. After these operations are completed, the voltage on the normal source shall be rapidly reduced to below random transfer setpoint for instantaneous random transfer verification.

MIL-PRF-32150B

Testing shall be performed with any convenient load. A calibrated phase angle sensing instrument shall be used to record the phase angle difference between the normal and alternate sources at the completion of each transfer. In each operation, except the instantaneous random transfer when voltage is reduced to below random transfer setpoint, the phase angle difference at the completion of transfer shall not exceed the in-phase monitoring setting.

When frequency sensing is specified, the switch shall be tested in each direction of frequency change and each direction of transfer by changing the frequency of the active source. Transfers initiated by frequency sensing may ignore in-phase monitoring.

4.6.1.9 Frequency sensing (CT21 and CT23). The frequency, as specified (see 6.2), shall be tested five times at the high and low frequency pickup points to determine compliance with the frequency requirements as specified (see 3.4.39 through 3.4.42).

4.6.1.10 Power available indicator. SABTs shall be operated to determine that each power available indicator operates properly when power is supplied and removed from each supply line.

4.6.1.11 Other required tests.

- a. Standard Operation Test - Examine proper SABT baseline operability.
- b. Diagnostic Fault Test - Inject faults, such as a shorted or open semiconductor switch, and examine proper diagnostic operation.

4.6.2 Line-to-ground impedance. Line-to-ground impedance tests shall be conducted in accordance with Method 302, test condition "B" of MIL-STD-202. Test conditions shall be as follows:

- a. Points of measure - Between each electrically isolated circuit and all other circuits connected together to ground (frame, chassis, or enclosure).
- b. Energized time - 60 seconds minimum for insulation testing (see 3.2.2).
- c. Temperature at time of test shall be in accordance with MIL-E-917.
- d. The insulation resistance or impedance to ground shall be measured with all operating components attached and connected in the SABT's normal operational condition with no internal wiring disconnected. Insulation resistance of SABTs shall be not less than 10 megohms as specified in MIL-E-917.

4.6.3 Operational source-to-source impedance. The SABT shall be tested for source-to-source impedance at 68 °F (20 °C) and 122 °F (50 °C) as stated below.

4.6.3.1 Source-to-source impedance and active ground test at 68 °F (20 °C). Refer to [figure 1](#) and [figure 2](#) to set-up the SABT at 68 °F (20 °C). Proceed as follows for verifying source-to-source impedance at 68 °F (20 °C). Ensure the specified test temperature remains constant throughout verification.

CAUTION: Make sure that the AC and DC power sources are isolated and use caution when changing connections.

- a. Refer to [figure 1](#). Apply 450 VAC, 60 Hz to CB1 and CB2 and set the load to 25 amps.
- b. Apply 500 VDC to Source #1, Phase A to ground, measure and record DC leakage. Remove 500 VDC. Apply 500 VDC to Source #1, Phase B to ground, measure and record DC leakage. Remove 500 VDC. Apply 500 VDC to Source #1, Phase C to ground, measure and record DC leakage. Remove 500 VDC.
- c. Close CB1 and measure DC leakage currents at Source #1, Phases A, B, and C and Source #2, Phases A, B, and C. Leakage currents should not exceed 0.25 mA.
- d. Close CB2 and CB3.
- e. Operate the SABT at a 25-amp load for 2 hours. Measure and record leakage currents at Source #1, Phases A, B, and C and Source #2, Phases A, B, and C.
- f. Source-to-source impedance equal to 500 VDC divides the difference of leakage currents obtained in steps c and e. Source-to-source impedance should be greater than 1.3 megohm.
- g. Open CB1, CB2, and CB3.

MIL-PRF-32150B

- h. Refer to [figure 2](#). Move the 500-volt DC power supply to Source #2 input and the 100 K load to Source #1 input. Change the Preferred Source switch on the SABB control panel as required.
- i. Close CB2, measure and record leakage currents at Source #1, Phases A, B, and C and Source #2, Phases A, B, and C. Leakage currents should not exceed 0.25 mA.
- j. Close CB1 and CB3.
- k. Operate the SABB at a 25-amp load for 2 hours. Measure and record leakage currents at Source #1, Phases A, B, and C and Source #2, Phases A, B, and C.
- l. Source-to-source impedance equal to 500 VDC divides the difference of leakage currents obtained in steps i and k. Source-to-source impedance should be greater than 1.3 megohm.

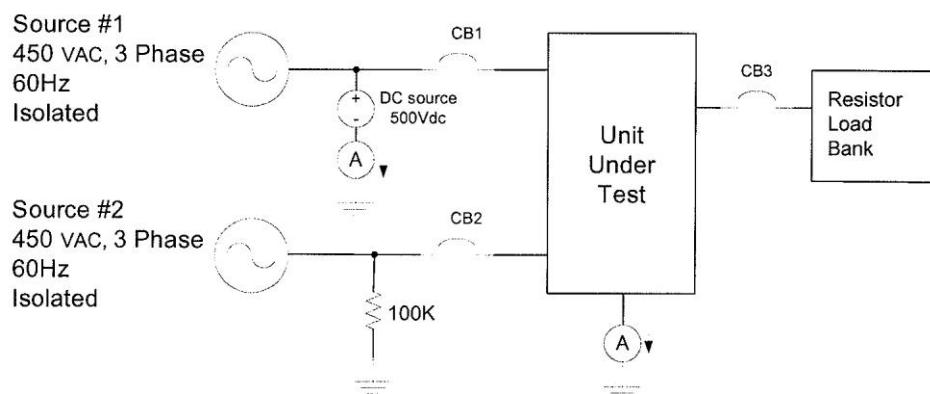

FIGURE 1. SABB active ground detector test (DC test source to normal).
(Note: "CB" stands for circuit breaker.)

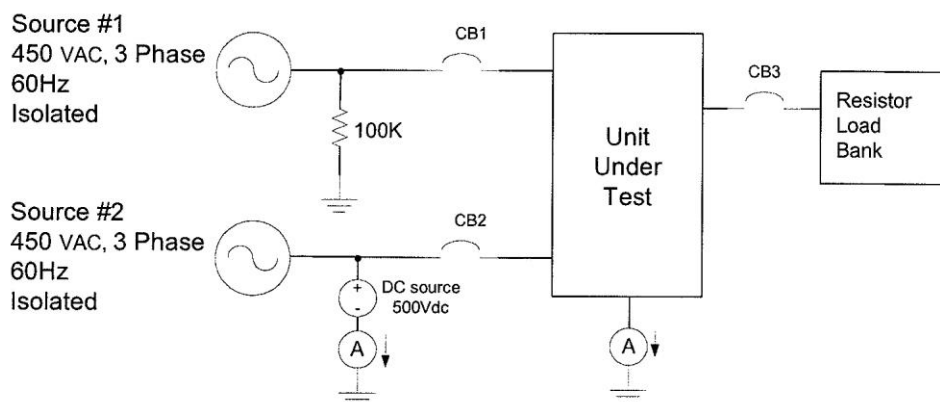

FIGURE 2. SABB active ground detector test (DC test source to alternate).
(Note: "CB" stands for circuit breaker.)

4.6.3.2 Source-to-source impedance and active ground test at 122 °F (50 °C). Proceed as follows for verifying the SABB source-to-source impedance at 122 °F (50 °C). Ensure test temperature remains constant throughout verification.

- a. Refer to [figure 1](#), apply 450 VAC, 60 Hz to CB1 and CB2 and set the load to 25 amps.
- b. Apply 500 VDC to Source #1, Phase A to ground, measure and record DC leakage current. Remove 500 VDC. Apply 500 VDC to Source #1, Phase B to ground, measure and record DC leakage current. Remove 500 VDC. Apply 500 VDC to Source #1, Phase C to ground, measure and record DC leakage current.

MIL-PRF-32150B

- c. Close CB1, measure and record DC leakage currents at Source #1, Phases A, B, and C and Source #2, Phases A, B, and C. Leakage currents should not exceed 0.5 mA.
- d. Close CB2 and CB3.
- e. Operate the SABT at a 25-amp load for 2 hours. Measure and record leakage currents at Source #1, Phases A, B, and C and Source #2, Phases A, B, and C.
- f. Source-to-source impedance equal to 500 VDC divides the difference of leakage currents obtained in steps c and e. Source-to-source impedance should be greater than 0.5 megohm.
- g. Open CB1, CB2, and CB3.
- h. Refer to [figure 2](#). Move the 500-volt DC power supply to Source #2 input and the 100 K load to Source #1 input. Change the Preferred Source switch on the SABT control panel as required.
- i. Close CB2, measure and record leakage currents at Source #1, Phases A, B, and C and Source #2, Phases A, B, and C. Leakage currents should not exceed 0.5 mA.
- j. Close CB1 and CB3.
- k. Operate the SABT at a 25-amp load for 2 hours. Measure and record leakage currents at Source #1, Phases A, B, and C and Source #2, Phases A, B, and C.
- l. Source-to-source impedance equal to 500 VDC divides the difference of leakage currents obtained in steps i and k. Source-to-source impedance should be greater than 0.5 megohm.
- m. Open CB1, CB2, and CB3.

4.6.4 Electromagnetic interference. When specified (see 6.2), the SABT shall be tested for EMI in accordance with MIL-STD-461.

4.6.5 Conducted emissions. The SABT shall be tested for conducted emissions in accordance with MIL-STD-461, Procedures CE101 and CE102. The upper limit of Procedure CE101 shall be extended to 20 KHz.

4.6.6 Conducted susceptibility. The SABT shall be tested for conducted susceptibility in accordance with MIL-STD-461, Procedures CS101, CS114, and CS116.

4.6.7 Conducted susceptibility, spikes, power leads. The SABT power leads, including grounds and neutrals, which are not grounded internally to the equipment, and interconnecting control leads, which provide power to the SABT, shall be tested. The SABT shall not exhibit any malfunction, degradation of performance, or deviation from specified indications, beyond the tolerances indicated when the test spike, having the waveform shown on [figure 3](#), is applied to the power leads for a period of time not less than 1 minute at each phase position and for a total test period not exceeding 15 minutes in duration. The values of E_1 and t_1 are given below. The spike shall be superimposed on the power line voltage waveform.

Spike $E_1 = 400$ volts; $t_1 = 5$ microseconds $\pm 20\%$

MIL-PRF-32150B

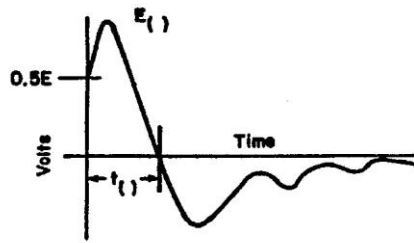

NOTE: The test sample shall be subjected to the spike(s) with the waveform shown and with the specified voltage (s) and pulsewidth (s).

FIGURE 3. Acceptable wave shape for conducted susceptibility, spikes, power leads.

4.6.8 Radiated emissions, AC magnetic field. The SABT shall be tested for radiated emission, AC magnetic field in accordance with MIL-STD-461, Procedure RE101.

4.6.9 Radiated emissions, AC electric field. The SABT shall be tested for radiated emissions, AC electric field in accordance with MIL-STD-461, Procedure RE102.

4.6.10 Radiated susceptibility, AC magnetic field. The SABT shall be tested for radiated susceptibility, AC magnetic field in accordance with MIL-STD-461, Procedure RS101.

4.6.11 Radiated susceptibility, DC magnetic field. The SABT shall be tested for radiated susceptibility, DC magnetic field in accordance with DOD-STD-1399-070-1.

4.6.12 Radiated susceptibility, AC electric field. The SABT shall be tested for radiated susceptibility, AC electric field in accordance with MIL-STD-461, Procedure RS103.

4.6.13 Radiated susceptibility, magnetic and electric fields, spikes and power frequencies.

4.6.13.1 Spike. The SABT shall not exhibit any malfunction, degradation of performance, or deviation from specified indications when subjected to the test spike having a wave form as shown on [figure 4](#). The values of E_1 and t_1 are as follows:

Spike $E_1 = 400$ volts; $t_1 = 5$ microseconds $\pm 20\%$

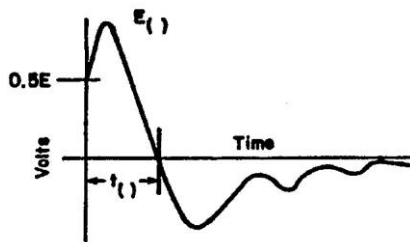

NOTE: The test sample shall be subjected to the spike(s) with the waveform shown and with the specified voltage (s) and pulsewidth (s).

FIGURE 4. Acceptable wave shape for radiated susceptibility, magnetic and electric fields, spikes and power frequencies.

MIL-PRF-32150B

4.6.13.2 Power frequency. The SABB shall not exhibit any malfunction, degradation of performance, or deviation from specified indications when 20 amps is applied to the test wire at the power frequency or frequencies of the SABB.

4.6.14 Power test. Power tests shall be conducted in both steady-state and transient for the following in accordance with MIL-STD-1399-300 during steady-state operation and during transfer at 180 degrees out of phase, with line capacitance to ground of 100 μf per phase and a load with a power factor of 1 at 20 amps:

- a. Voltage and frequency tolerance
- b. Voltage and frequency transient tolerance
- c. Voltage spike
- d. Emergency condition
- e. Grounding
- f. User equipment power profile (at no load)
- g. Current waveform
- h. Equipment (insulation resistance)
- i. Voltage and frequency modulation

4.6.15 Chassis leakage current. The SABB shall be tested for chassis leakage current in accordance with MIL-E-917.

4.6.16 Compatibility with active ground fault detector circuit. When specified (see 3.4.43 and 6.2), the SABB shall be tested with an active ground fault detector circuit utilizing a 500-volt DC power supply and shall:

- a. Have a source-to-source impedance as high as possible, but not less than 0.5 megohm at 122 °F (50 °C).
- b. Have a minimum source-to-ground impedance of at least 10 megohms.
- c. Not cause a low-impedance to ground fault condition detected on one source to be imposed on, transferred to, or reflected on the other source.

4.6.17 Endurance and overload. Unless otherwise specified (see 6.2), SABBs shall be tested for overload and endurance in accordance with [table VII](#). Switches shall be energized for a minimum of $\frac{1}{2}$ of a second before and after transfer. Operation cycles shall be initiated by the loss of power from either source. The SABB shall be powered down between operation cycles. However, in no case shall the specified operating cycles cause damage to components from excessive heating. SABBs shall fail the overload and endurance tests if they fail to perform their intended operating functions during or after the tests without adjustment, calibration, or replacement of parts.

TABLE VII. Endurance and overload test conditions.

Overload test conditions				
Number of cycles of operations	Test current (percent rated)	Test voltage (percent rated)	Load power factor	Time limit
50	150	100	0.70-0.80	1 hour 40 minutes
Endurance test conditions				
Number of cycles of operations	Test current (percent rated)	Test voltage (percent rated)	Load power factor	Minimum make and break operating cycles
6000	100	100	0.80	6 per minute

MIL-PRF-32150B

4.6.18 Short-circuit withstandability. SABTs and SABT auxiliary switches shall be tested for short-circuit withstandability in accordance with MIL-DTL-16036. The SABTs shall be subjected to and pass the dielectric withstanding voltage test as specified in [table III](#) after the short-circuit withstandability tests without adjustment, calibration, or replacement of parts. The test circuit current shall be measured, instrumented, and calibrated in accordance with UL 1008. SABTs shall fail the short-circuit withstandability tests if one or more of the following occurs after the withstandability test:

- a. Malfunction occurs that prevents one transfer and re-transfer action by manual means.
- b. Malfunction occurs to prevent transfer and re-transfer automatically at rated conditions.

4.6.19 Dielectric withstanding voltage. Dielectric withstanding voltage tests shall be conducted in accordance with Method 301 of MIL-STD-202. Magnitude of test voltage for circuits rated more than 60 V but not greater than 450 V, the rms test voltage shall be twice rated circuit voltage plus 1000 V.

4.6.20 Degree of enclosure. SABTs shall be tested in accordance with MIL-E-2036 for Class I enclosures, as supplemented by MIL-STD-108.

4.6.21 Remote monitoring and control.

- a. SABT shall provide remote indication of whether the Normal or Alternate source of power is currently connected to the load.
- b. SABT shall monitor and provide remote indication when the Normal or the Alternate power source is no longer available.
- c. SABT shall provide remote capability to receive and command the SABT to the Alternate power source.
- d. SABT shall provide remote indication of internal, electronic failure that would prevent selection of an available power source.
- e. SABT shall provide remote indication anytime the remote monitoring and control function is inoperative.

4.6.22 Ambient temperature. The SABT shall be designed for continuous reliable operation within specified limits over an ambient temperature range of 32 to 122 °F (0 to 50 °C). Testing shall be in accordance with MIL-STD-202.

4.6.23 Humidity. The SABT shall be subjected to the humidity testing in accordance with MIL-STD-810.

4.6.24 Pressure. The SABT shall operate within the specified performance limits while subjected to an atmospheric pressure from 24 to 36 inches of mercury in accordance with MIL-STD-202.

4.6.25 Temperature rise. SABTs shall be subjected to a temperature rise test. The test shall be conducted with the SABTs carrying rated current in accordance with MIL-DTL-16036.

4.6.26 Inclined operation. SABTs shall be operated at rated voltage and frequency and tested in accordance with MIL-E-917.

4.6.27 Shock. SABTs shall be subjected to shock tests in accordance with MIL-S-901 for Grade A, Class I, Type A equipment with weight classification as required by the weight of the equipment. The SABT shall be tested in the same mounting configuration as the one chosen for shipboard installation. SABTs rated over 100 amps shall be tested at rated voltage and frequency and 10 percent of rated current. SABTs rated at 100 amps or less shall be tested at rated voltage and frequency and 10 amps. Control circuits shall be energized as in actual service. An oscillograph shall be used to check the closed contacts for excessive contact bounce and to check open contacts for momentary closure. SABT mounting shall be as specified for standard mounting for bulkhead-mounted equipment in accordance with MIL-S-901. Fuses (or other indicators which provide a positive indication) shall be connected in a manner to detect any momentary shorting between live parts or live parts and ground. The SABTs being tested shall not be reconditioned or adjusted during the testing. SABTs shall fail the test if it cannot perform its intended operating functions during and after such tests, or if one or more of the following occurs during the tests:

- a. Contact occurs between live parts and the enclosure.
- b. Enclosure door opens.

MIL-PRF-32150B

- c. Structural parts are damaged or loosened.
- d. Functional parts are damaged or loosened.
- e. Inadvertent transfer of load due to the force of shock blow.
- f. Contacts have contact bounce in excess of 0.02 second per bounce.
- g. Closed auxiliary contacts momentarily open or open auxiliary contacts momentarily close.

Note: The SABTs shall be thoroughly examined after the tests to determine whether there is evidence of items c and d above.

4.6.28 Vibration. SABTs shall be subjected to Type I vibration tests in accordance with MIL-STD-167-1. The tests shall be conducted with the SABT in each operating position. SABTs rated over 100 amps shall be tested at rated voltage and frequency and 10 percent of rated current. SABTs rated 100 amps or less shall be tested at rated voltage and frequency and 10 amps. Control circuits shall be energized as in actual service. An oscillograph shall be used to check the closed contacts for excessive contact bounce and to check open contacts for momentary closure. Fuses (or other indicators which provide a positive indication) shall be connected in a manner to detect any momentary shorting between live parts or live parts and ground. SABTs shall fail the test if it cannot perform its intended operating functions during and after such tests, or if one or more of the following occurs during the tests:

- a. Contact occurs between live parts and the enclosure.
- b. Enclosure door opens.
- c. Structural parts are damaged or loosened.
- d. Functional parts are damaged or loosened.
- e. Inadvertent transfer of load.
- f. Re-transfer operation is initiated.
- g. Closed auxiliary contacts momentarily open or open auxiliary contacts momentarily close.

Note: The SABTs shall be thoroughly examined after the tests to determine whether there is evidence of items c and d above.

4.6.29 Airborne noise. When specified (see 6.2), the SABT shall be tested for airborne noise in accordance with MIL-STD-1474.

4.6.30 Structureborne noise. When specified (see 6.2), the SABT shall be tested for structureborne noise in accordance with MIL-STD-740-2.

4.6.31. Operating voltages. SABTs shall be able to handle voltage and current harmonics in excess of those required in MIL-STD-1399-300 as required in section 6.2.

5. PACKAGING

5.1 Packaging. For acquisition purposes, the packaging requirements shall be as specified in the contract or order (see 6.2). When packaging of materiel is to be performed by DoD or in-house contractor personnel, these personnel need to contact the responsible packaging activity to ascertain packaging requirements. Packaging requirements are maintained by the Inventory Control Point's packaging activities within the Military Service or Defense Agency, or within the military service's system commands. Packaging data retrieval is available from the managing Military Department's or Defense Agency's automated packaging files, CD-ROM products, or by contacting responsible packaging activity.

MIL-PRF-32150B

6. NOTES

(This section contains information of a general or explanatory nature that may be helpful, but is not mandatory.)

6.1 Intended use. SABTs are intended for use in naval shipboard applications as devices that automatically or manually transfer power supply lines via its internal solid-state components to a connected load. When accomplished automatically, control circuits determine when and in what manner the transfer will occur.

6.2 Acquisition requirements. Acquisition documents should specify the following:

- a. Title, number, and date of this specification.
- b. PIN (see 1.3).
- c. Specific issue of the individual documents referenced, if required (see 2.2.1 and 2.3).
- d. Instruction sheets (see 3.2.14).
- e. Adjustable configuration settings, if required (see 3.2.15).
- f. Different weight and size requirements (see 3.3).
- g. Special features (see 3.4.1).
- h. Operating voltage (see 3.4.3.3).
- i. Operating frequency (see 3.4.3.8).
- j. Special frequency variation for frequency sensing SABTs (see 3.4.3.8).
- k. Full phase protection for SABTs, if not allowed (see 3.4.3.9).
- l. Special auxiliary switch requirements, if necessary (see 3.4.11).
- m. When more than 12 external control wires are required (see 3.4.12).
- n. When a higher source-to-source impedance is required (see 3.4.13.3).
- o. Design for high resistance grounded systems (see 3.4.15).
- p. EMI criteria, if required (see 3.4.17).
- q. When the SABT does not require air gap isolation between sources (see 3.4.29.4).
- r. Adjustable over-frequency setpoint (see 3.4.39).
- s. Adjustable over-frequency pickup (see 3.4.40).
- t. Adjustable under-frequency setpoint (see 3.4.41).
- u. Adjustable under-frequency pickup (see 3.4.42).
- v. Active ground fault detection requirement (see 3.4.43).
- w. Special endurance and overload requirements, if required (see 3.4.44).
- x. Special short-circuit withstandability test, if required (see 3.4.45).
- y. Degree of enclosure (see 3.4.47).
- z. Remote monitoring and control features (see 3.4.48).
- aa. Airborne noise limits, if required (see 3.5.9).
- bb. Structureborne noise limits, if required (see 3.5.10).
- cc. Manufacturer provided written warranty.

MIL-PRF-32150B

6.3 Qualification. With respect to products requiring qualification, awards will be made only for products, which are, at the time of award of contract, qualified for inclusion in Qualified Products List QPL No. 32150 whether or not such products have actually been so listed by that date. The attention of the contractors is called to these requirements, and manufacturers are urged to arrange to have the products that they propose to offer to the Federal Government tested for qualification in order that they may be eligible to be awarded contracts or orders for the products covered by this specification. Information pertaining to qualification of products may be obtained from Commander, Naval Sea Systems Command, ATTN: SEA 05S, 1333 Isaac Hull Avenue, SE, Stop 5160, Washington Navy Yard, DC 20376-5160 or emailed to CommandStandards@navy.mil. An online listing of products qualified to this specification may be found in the Qualified Products Database (QPD) at <https://assist.dla.mil>.

6.3.1 Provisions governing qualification. Copies of SD-6, "Provisions Governing Qualification", are available online at <http://quicksearch.dla.mil/> or <https://assist.dla.mil>.

6.4 Definitions. For the purpose of the following definitions, the SABT is assumed to be in automatic with the normal source supplying the loads unless specifically indicated otherwise. Note that in manual, the SABT will remain lined up to the operator-selected power source regardless of the availability of either source. Also, it is assumed that the SABT is based on semiconductor switch technology. If this is not the case, reference to semiconductor switches should be appropriately interpreted.

6.4.1 Active source. The active source is the source that is actually powering the load. The active source is indicated on the front panel.

6.4.2 Available source. A power source that has no open circuited semiconductor switches and whose voltage is above the pickup voltage setpoint. Additionally, if the over/under frequency transfer (see 6.4.29) features are enabled, the source frequency will also have to be between the under frequency transfer and the over frequency transfer for the source to be considered available. When a source is available, it will be so indicated on the front panel.

6.4.3 Continuous duty. Operation at substantially constant load for an unlimited period of time is considered continuous duty.

6.4.4 Control circuits. Control circuits are solid-state (semiconductor) circuits that sense and control the transfer from normal to alternate power sources and re-transfer or otherwise control operation of the SABT.

6.4.5 Full phase protection. Full phase protection occurs when an SABT device monitors all phase voltages of one power source and initiates transfer of the connected load from the active power source to another when voltage of the active power source drops below a predetermined value. The device initiates transfer of the connected load back to the preferred power source when all voltages of the preferred source return to within specified limits.

6.4.6 Indicator circuits. Circuits that sense and transmit status or condition of aspects of the SABT, such as: power to load, status of each power source, automatic or manual, presence of internal fault logic and identification of preferred power source, and provides visible and audible alarm and status indications for these and other unit anomalies.

6.4.7 Inhibit transfer. When a shorted semiconductor is detected by the SABT, the inhibit transfer feature ensures the SABT will transfer to (or remained lined up to) the source with the shorted semiconductor and inhibit further transfers.

6.4.8 In-phase monitoring. In-phase monitoring for sensing and control is a device used to sense the phase angle between the normal and alternate sources prior to load transfer. It is used with a two-way instantaneous type SABT switch to initiate transfer only when the two sources are nearly synchronized thereby limiting the motor inrush current to below normal starting current levels and avoiding inadvertent circuit breaker tripping.

6.4.9 In-phase transfer. In-phase transfer is the voltage threshold below which the unit senses an in-phase under-voltage condition. If the condition is on the active source, the source will no longer be considered available and the SABT will transfer to the alternate source. Transfer will be initiated only if the alternate source is available. If the phase angle difference feature is enabled, transfer will occur only if the phase mismatch between the sources is less than the preset phase angle difference.

MIL-PRF-32150B

6.4.10 Instantaneous. A qualifying term indicating that no delay is purposely introduced in the action of the SABB switch.

6.4.11 Normal seeking. Function of SABB preferentially to seek out and provide power to the load from the normal power source whenever the normal power source is available. However, it will transfer to the alternate power source and provide power to the load from that source if the normal power source drops below preset values and the alternate power source is available.

6.4.12 Normal source, alternate source. This establishes an arbitrary convention to distinguish between the two sources. Which source is normal and which is alternate depends entirely on which set of bus bars the cables from the two available power sources are connected to inside the SABB and hence is independent of which source should supply the load under normal operation. The term “normal” should therefore not be confused with “preferred”.

6.4.13 Operating transfer time. Operating transfer time is the time measured from the instant of monitored voltage source deviation to the recognition of an available alternate source, exclusive of any purposely introduced time delay.

6.4.14 Over-frequency pickup. Over frequency pickup is the frequency threshold below which a power source that has previously exceeded the over frequency setpoint is considered to have reverted to an available state.

6.4.15 Over-frequency setpoint. The frequency above which a power source is no longer considered available.

6.4.16 Phase angle difference. Phase angle difference is monitored only if the phase angle difference feature is enabled. The phase angle difference is measured between the normal and alternate sources.

6.4.17 Phase angle difference feature. A feature that, when enabled, allows the unit to monitor the phase mismatch between power sources. When the feature is disabled, transfer will occur instantaneously upon the active source voltage reaching the in-phase transfer voltage setpoint. Transfer will occur regardless of the phase mismatch between sources. Disabling the phase angle difference feature will also allow re-transfer (if enabled) to occur regardless of phase mismatch between sources, as long as the preferred source has been restored to an available state.

6.4.18 Pickup voltage. The pickup voltage of a device is the minimum voltage at which the device starts to operate. Also, the lowest voltage of a power source at which the SABB will consider that source available, provided the other monitored parameters (over frequency and under frequency) are also within their acceptable ranges and there are no open semiconductor switches on that source.

6.4.19 Power seeking. Function of SABB that has no preference to normal or alternate power source to provide power to the load. It will provide power to the load from whichever source becomes available first. It will remain on that source and stay on that source until that power source drops below preset values and transfer the other power source if it is available.

6.4.20 Preferred source. The source to which the SABB will automatically re-transfer the load in the event both power sources become available. Either normal or alternate source can be selected to be preferred. If the re-transfer feature is not active, however, the term effectively has no meaning. When a source is selected as preferred, it will be so indicated on the front panel.

6.4.21 Random transfer. The voltage threshold of the active power source at which the SABB initiates a random transfer to the inactive power source, provided the inactive source is available. When this threshold is reached, transfer will occur regardless of phase mismatch between power sources. Note that when the phase angle difference feature is disabled, transfer will occur on the basis of the in-phase transfer voltage setpoint only. However, even in this case, the random transfer voltage will be utilized (in concert with an overload condition) by the SABB control logic to determine that a problem with the load has occurred and inhibit transfers.

MIL-PRF-32150B

6.4.22 Re-transfer. The automatic switching of loads from the non-preferred to the preferred source after a transfer has occurred earlier and subsequently the preferred source has become available. If the phase angle difference feature is enabled, the re-transfer is performed only with the sources within the maximum allowed phase angle difference, otherwise it will occur regardless of phase mismatch between sources. The re-transfer feature can be disabled, in which case, there is effectively no preferred source; the SABT will not automatically re-transfer loads after the preferred source has been restored to an available state. An indicator on the front panel is lit if the re-transfer feature is enabled.

6.4.23 SABT. The SABT is a solid-state, self-acting device for transferring one or more load cable connections from one power source to another.

6.4.24 SABT operation. SABT operation is the transfer or the re-transfer of the connected load from one power source to another.

6.4.25 SABT power source. Either the Normal or Alternate source may be selected as the preferred source for a given application. The preferred source is usually the Normal supply line or source.

6.4.26 Short-circuit withstandability. Short-circuit withstandability is the ability of the SABT switch switching mechanism to carry the required short-circuit current without permanent damage for the period of time necessary for circuit protective devices in the system to clear the fault.

6.4.27 Transfer. Transfer is the switching of loads from one available source to an alternate available source. It is initiated by the SABT sensing that the available source is outside preset transfer limits while the alternate source is available.

6.4.28 Transfer stabilization time. Transfer stabilization time is the interval of time where the normal source has reached predetermined setpoints for availability at which time the re-transfer from the alternate to the normal is permitted. Transfer stabilization time is not applicable when the re-transfer feature is disabled because in this case the unit will not re-transfer to the designated (normal) source.

6.4.29 Under frequency transfer. Under frequency transfer is the frequency threshold below which a power source is no longer considered available.

6.5 Acronyms.

EMI	Electromagnetic Interference
ESD	Electrostatic Discharge
FL	Fault Localization
GUI	Graphical User Interface
PM	Performance Monitoring
RMS	Root Mean Square
SABT	Static Automatic Bus Transfer Switch

6.6 Subject term (key word) listing.

Silicon controlled rectifier
Switch gear
Switching mechanism

6.7 Changes from previous issue. Marginal notations are not used in this revision to identify changes with respect to the previous issue due to the extent of the changes.

MIL-PRF-32150B

Custodians:

Army - CR4

Navy - SH

Air Force - 99

Preparing activity:

Navy – SH

(Project 6110-2011-001)

Reviewing activities:

Navy - AS, CG

Air Force - 03, 19

DLA - GS, GS2

NOTE: The activities listed above were interested in this document as of the date of this document. Since organizations and responsibilities can change, you should verify the currency of the information above using the ASSIST Online database at <https://assist.dla.mil>.