

INCH-POUND

MIL-PRF-32052/10(CR)

7 December 1999

PERFORMANCE SPECIFICATION SHEET

BATTERY, RECHARGEABLE, SEALED, BB-X112/U

This specification sheet is approved for use by the U. S. Army CECOM, Department of the Army, and is available for use by all Departments and Agencies of the Department of Defense.

The requirements for acquiring the product described herein shall consist of this specification sheet and the issue of the following specification listed in that issue of the Department of Defense Index of Specifications and Standards (DODISS) specified in the solicitation: MIL-PRF-32052.

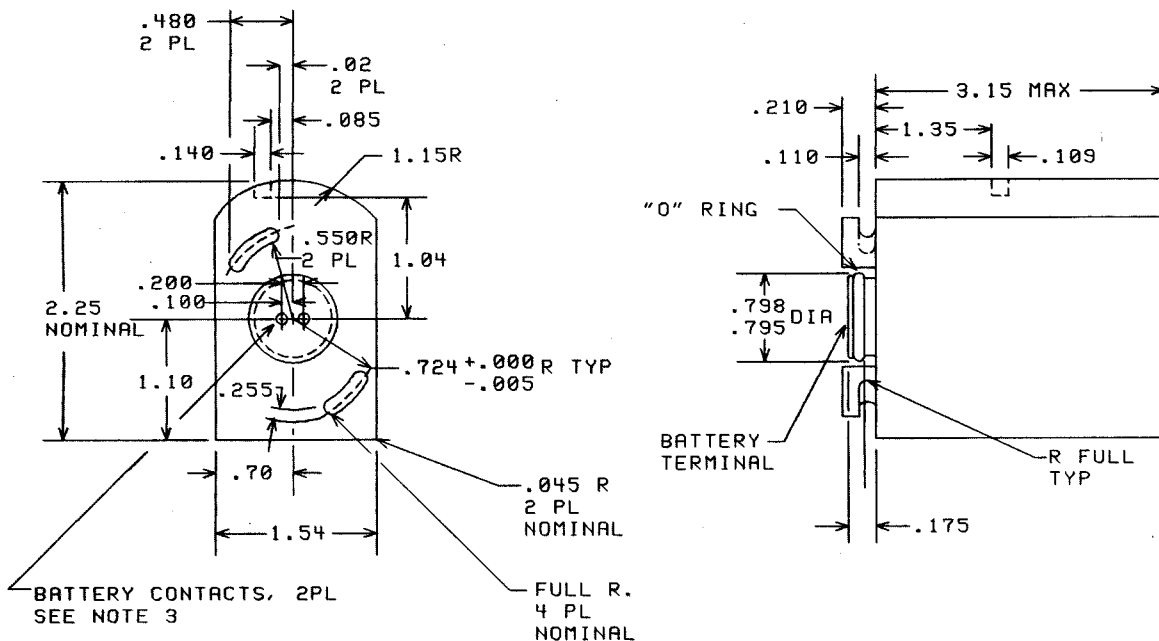

Figure 1. Battery dimensions.

AMSC N/A

1 of 5

FSC 6140

DISTRIBUTION STATEMENT A. Approved for public release; distribution is unlimited.

MIL-PRF-32052/10(CR)

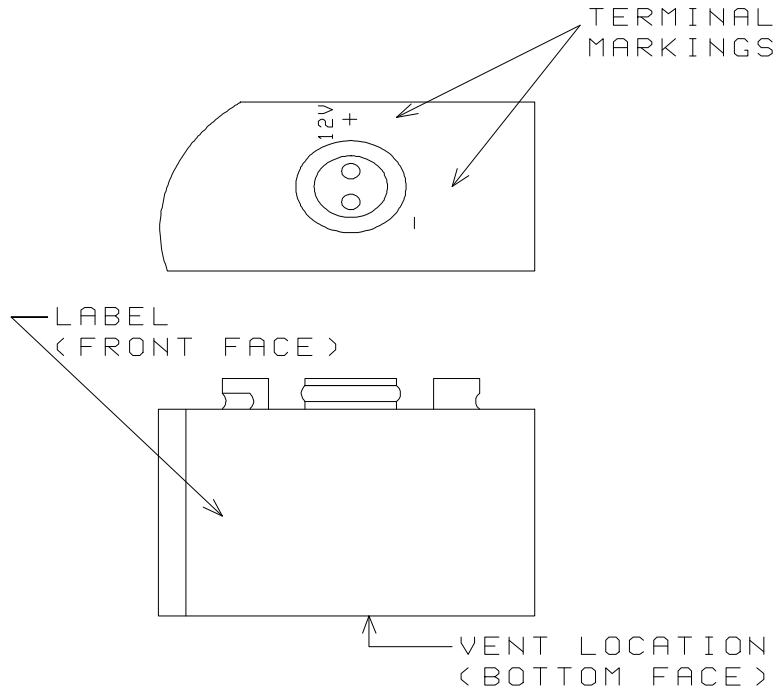

Figure 2. Terminal markings.

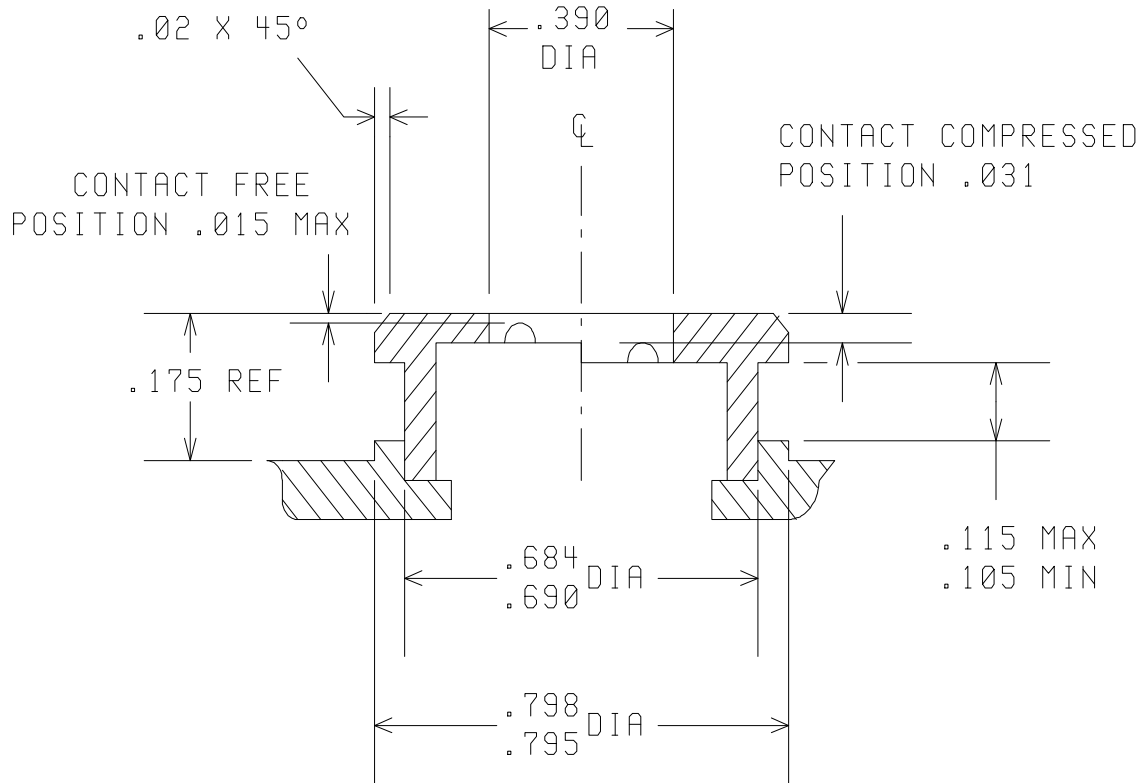

Figure 3. Contact Configuration.

MIL-PRF-32052/10(CR)

NOTES:

1. All dimensions are in inches.
2. Tolerances are: 2 place decimals $\pm.01$.
3 place decimals $\pm.005$.
3. The contacts shall not protrude above the surface of the battery terminal. The contact's diameter shall be $.109\pm.005$ inch and the contact surface shall be smooth.

REQUIREMENTS:

Rated capacity (C/5): 2.7 AH.

Voltage (Nominal): 11.1 Volts.

Weight (Maximum) 0.300 Kg (0.7 lb).

Dimensions and configuration: See Figure 1 and Figure 3.

Terminals: 2 pin contact, coupler interface, "O" ring sealed (see Figure 1 and 3).

Battery contacts: The contacts shall be constructed from tubular, oval head rivets conforming to the interface and dimensional requirements of MS16535-11. The contacts shall require a minimum mating force of 15 ounces per contact.

O-ring seal: The battery when subjected to the O-ring seal test shall not increase in weight by more than 0.1 grams and the O-ring shall prevent the water from contacting the battery contacts and the battery terminal face. There shall be no sign of corrosion on the battery contacts.

State of Charge Indicator Location: The state of charge indicator shall be located on either the top or bottom of the battery.

Charge connector location: The charge connector shall be located on the bottom of the battery.

Charge rate for testing

and on battery (C/2 for 2-3 hrs): 1.35 amps minimum .

(or when permitted, per 4.7.1.2)

MIL-PRF-32052/10(CR)

<u>Discharge Rates</u>	<u>5 Second Voltage(V)</u>	<u>Final Voltage(V)</u>	<u>Current (Amps)</u>
C/3.8	-	8.0	0.65
C ₅	-	8.0	2.5
2 C ₅	11.0	8.0	5.0

<u>Test</u>	<u>Current (amperes)</u>	<u>Capacity Requirement (AH)</u>
Full Capacity Discharge	0.65	2.5
Cycle Life, 224 cycles	0.65	2.2
Overcharge, 24 hours	0.65	2.5
High Rate Discharge	5.0	2.0
Low Temperature Discharge at -20°C (-4°F)	0.65	1.5
Retention of Charge 7 days at 50°C (122°F)	0.65	1.3
Intermittent Load		2.5
5 Minutes on	0.65	
5 Minutes rest	0	
Vibration	0.65	2.5

NOTES –

1. Unless otherwise specified, all values are minimum.
2. All charges and discharges shall be performed on fully assembled batteries through the terminals.
3. Electrical leakage : Not applicable.
4. All the discharge rate are fixed current regardless the capacity of the battery.

Connector: Battery connector shall be capable of withstanding a minimum of 500 coupling and uncoupling with charging cable with no breakage, distortion or loss of electrical performance.

Charging connector (not shown) shall be located in opposite side to battery terminals . The charging connector shall be able to mate to the charger connector.

Venting mechanism: The battery case venting mechanism shall be monitored during the safety feature test. During cell venting the battery venting mechanism shall release the pressure build up in the battery case and shall meet the performance requirements specified herein.

MIL-PRF-32052/10(CR)

O-ring seal test: The samples used for the first article inspection and group C inspection shall be used. This test shall be performed on the same samples used for the transient drop test. It shall be performed after the transient drop test and prior to the remainder of the test sequence. The immersion test is not required for the samples that are subjected to this test. The weight of each battery sample shall be measured and recorded. The samples shall be mated to a Motorola part number 64-P21451J001 coupler plate or equal. The coupler plate shall be waterproofed, except at the battery/ coupler plate interface, to prevent water from contacting the battery connector contacts. The battery/plate assemblies shall be immersed in a synthetic solution containing 3.6 percent by weight sea salt in accordance with ASTM-D-1141. The solution with the battery samples shall be pressurized to simulate two foot immersion for 24 hours and the pressure shall be raised to simulate 50 foot immersion for 8 hours. The battery samples shall be removed from the solution and separated from the coupler plate. The battery contacts shall be inspected for evidence of water. The batteries shall be towel dried and left to air dry for 15 minutes. The batteries shall be weighed and shall meet the O-ring seal requirements specified.

CONCLUDING MATERIAL:

Custodian:
Army - CR

Preparing Activity:
Army - CR

(Project 6140-A913-10)