

INCH-POUND

ML-PRF-31033  
9 August 1996

## PERFORMANCE SPECIFICATION

CAPACITORS, FIXED, CERAMIC DIELECTRIC, HIGH  
RELIABILITY, DISCOIDAL, GENERAL SPECIFICATION FOR

This specification is approved for use by all Departments  
and Agencies of the Department of Defense.

## 1. SCOPE

1.1 Scope. This specification covers the requirements for high reliability, discoidal, ceramic dielectric, fixed capacitors. This specification provides for three levels of product requirements: Class C, Class B, and Class S. Capacitors furnished to the requirements of this specification are intended for use in Radio Frequency/Electromagnetic Interference (RF/EMI) suppression filters covered by MIL-PRF-28861. This specification establishes a Qualified Manufacturers List (QML) for discoidal capacitors that requires demonstration of control of the quality system and manufacturing process and qualification of representative discoidal capacitor designs.

1.2 Classification. Discoidal capacitors are classified into one of the following reliability levels as specified (see 6.2).

1.2.1 Product level. Three product levels of discoidal capacitors are provided for in this specification. The product level is identified by a single letter in accordance with table I:

TABLE I. Product level.

Symbol	Level
C	Class C
B	Class B
S	Class S

- a. Class C - Class C is the commercial high reliability level of this specification and is intended for those applications where full conformance inspection is not required. The in-process inspection of this specification and the manufacturer's normal screening/testing is still required.
- b. Class B - Class B is the base product level of this specification and is intended for all applications except for space applications. Class B discoidal capacitors are those which have been subjected to and passed all applicable requirements, tests, and inspections detailed herein, including qualification and conformance inspection requirements for Class B.
- c. Class S - Class S is the highest product level of this specification and is intended for space applications. Class S discoidal capacitors are those which have been subjected to and passed all applicable requirements, tests, and inspections detailed herein, including qualification and conformance inspection requirements for Class S.

Beneficial comments (recommendations, additions, deletions) and any pertinent data which may be of use in improving this document should be addressed to: Defense Supply Center, Columbus, ATTN: VAM 3990 East Broad Street, Columbus, OH 43216-5000 using the Standardization Document Improvement Proposal (DD Form 1426) appearing at the end of this document or by letter.

## ML-PRF-31033

## 2. APPLICABLE DOCUMENTS

2.1 General. The documents listed in this section are specified in sections 3 and 4 of this specification. This section does not include documents cited in other sections of this specification or recommended for additional information or as examples. While every effort has been made to ensure the completeness of this list, document users are cautioned that they must meet all specified requirements of the documents cited in sections 3 and 4 of this specification, whether or not they are listed.

2.2 Government documents.

2.2.1 Specifications, standards, and handbooks. The following specifications, standards, and handbooks form a part of this document to the extent specified herein. Unless otherwise specified, the issues of these documents are those listed in the issue of the Department of Defense Index of Specifications and Standards (DoDISS) and supplement thereto, cited in the solicitation (see 6.2).

## SPECIFICATIONS

## DEPARTMENT OF DEFENSE

MIL-PRF-28861 - Filters and Capacitors, Radio Frequency/Electromagnetic Interference Suppression.

## STANDARDS

## DEPARTMENT OF DEFENSE

MIL-STD-202 - Test Methods for Electronic and Electrical Component Parts.  
MIL-STD-790 - Standard Practice for Established Reliability and High Reliability Qualified Products List (QPL) Systems for Electrical, Electronic, and Fiber Optic Parts Specifications.

(Unless otherwise indicated, copies of the above specifications, standards, and handbooks are available from the Defense Printing Service Detachment Office, Building 4D, Customer Service, 700 Robbins Avenue, Philadelphia, PA 19111-5094.)

2.3 Non-Government publications. The following documents form a part of this document to the extent specified herein. Unless otherwise specified, the issues of the documents which are DoD adopted are those listed in the issue of the DoDISS cited in the solicitation. Unless otherwise specified, the issues of documents not listed in the DoDISS are the issues of the documents cited in the solicitation (see 6.2).

## AMERICAN NATIONAL STANDARDS INSTITUTE (ANSI)

ANSI/J-STD-006 - Requirements for Electronic Grade Solder Alloys and Fluxed and Non-Fluxed Solid Solders for Electronic Soldering Applications.

(Applications for copies should be addressed to the American National Standards Institute, Inc., 11 West 42nd Street, New York, NY 10036-8002.)

## ELECTRONIC INDUSTRIES ASSOCIATION (EIA)

EIA-557 - Statistical Process Control Systems.  
RS-198 - Ceramic Dielectric Capacitors.  
RS-469 - Standard Test Method for Destructive Physical Analysis of High Reliability Ceramic Monolithic Capacitors.

(Application for copies should be addressed to the Electronic Industries Association, 2500 Wilson Boulevard, Arlington, VA 22201-3834.)

2.4 Order of precedence. In the event of a conflict between the text of this document and the references cited herein, the text of this document takes precedence. Nothing in this document, however, supersedes applicable laws and regulations unless a specific exemption has been obtained.

## ML-PRF-31033

## 3. REQUIREMENTS

3.1 Qualification. Capacitors furnished under this specification shall be products that are manufactured by a manufacturer authorized by the qualifying activity for listing on the applicable qualified manufacturers list before contract award (see 4.5 and 6.3). In addition, manufacturers shall obtain certification from the qualifying activity that the requirements of 4.1 have been met and are being maintained.

3.2 Product levels. Three product levels of capacitors are provided for in this specification. Class S and Class B capacitors shall be those which have been subjected to and passed all applicable requirements, tests, and inspections detailed herein, including qualification and conformance inspection requirements for the specified class. Class C capacitors shall be those which have been subjected to and passed the in-process inspection of this specification and the manufacturer's normal screens/tests and inspections, which shall be documented in the MIL-STD-790 product system. Class C capacitors must be the same characteristics as the Class B counterpart. Class S is the highest product level of this specification and is intended for space applications.

3.3 Qualified Manufacturer's List (QML) system elements. The manufacturer shall establish a system for capacitors furnished to this specification that meets the requirements of MIL-STD-790.

3.3.1 Statistical process control (SPC) system. As part of the MIL-STD-790 system, the manufacturer shall establish an SPC system that meets the requirements of EIA-557. Typical manufacturing processes for application of SPC are: Raw material mixing and blending; dielectric sheet manufacturing; stacking and electrode printing; laminating; discoidal firing; termination, and packaging.

3.4 Materials. The materials shall be as specified herein. However, when a definite material is not specified, a material shall be used which will enable the discoidal capacitors to meet the performance requirements of this specification. Acceptance or approval of any constituent material shall not be classified as a guaranty of the acceptance of the finished product.

3.5 Documentation of individual discoidal capacitors. Manufacturers of filters built in accordance with MIL-PRF-28861 shall specify the requirements of individual discoidal capacitors which shall include, but is not limited to the following types of performance requirements:

- a. Physical dimensions and terminations (see 3.7).
- b. Dielectric constant (see 3.6).
- c. Minimum dielectric thickness (see 3.6.1).
- d. Electrical characteristics:
  - (1) Voltage rating (see 3.6.1).
  - (2) Capacitance and tolerance (see 3.8).
  - (3) Dissipation factor (see 3.9).
  - (4) Insulation resistance (see 3.11).
  - (5) Voltage-temperature limits (see 3.18).

3.6 Dielectric parameters. Capacitors supplied to this specification shall meet the following performance characteristic requirements:

Class S - X7R/BX or C0G/NP0 (0 ppm  $\pm$ 30 ppm) dielectric as specified in the EIA standard RS-198.

Class B and C - X7R/BR or C0G/NP0 (0 ppm  $\pm$ 30 ppm) dielectric as specified in the EIA standard RS-198.

3.6.1 Dielectric thickness. Capacitors supplied to this specification shall have a minimum dielectric thickness of 0.020 mm (0.8 mil) for capacitors with ratings of 50 volts and below or 0.025 mm (1.0 mil) for capacitors with ratings above 50 volts. Dielectric thickness is the actual measured thickness of the fired ceramic dielectric layer. Voids, or the cumulative effect of voids, shall not reduce the total dielectric thickness by more than 50 percent.

3.7 Physical dimensions and terminations. The discoidal capacitor dimensions and terminations shall meet the requirements specified by the procuring activity (see 3.5).

3.8 Capacitance. The individual item requirements as measured by 4.7.4 shall be as specified by the procuring activity (see 3.5).

3.9 Dissipation factor. When determined as specified in 4.7.5, the dissipation factor shall not exceed 2.5 percent for X7R/BX and X7R/BR, and 0.15 percent for C0G/NP0.

ML-PRF-31033

3.10 Dielectric withstanding voltage. Capacitors shall withstand the direct current (dc) potential specified in 4.7.6 without damage or breakdown.

3.11 Insulation resistance. When measured as specified in 4.7.7, the insulation resistance shall not be less than the value specified:

At 25° C - 100,000 megohms or 1,000 megohm-microfarads, whichever is less.

At 125° C - 10,000 megohms or 100 megohm-microfarads, whichever is less.

3.12 Destructive physical analysis. When examined as specified in 4.7.8, capacitors shall meet the requirements of EIA standard RS-469.

3.13 Nondestructive internal examination (Class S only) (see appendix B). All capacitors delivered to this specification shall be subjected to ultrasonic examination or some other method of nondestructive internal examination as determined by the manufacturer and approved by the procuring activity.

3.13.1 Ultrasonic examination (Class S only). When capacitors are tested as specified in 4.7.1.1, there shall be no devices delivered that show unacceptable responses as defined in appendix B.

3.14 Visual examination. When examined as specified in 4.7.2, capacitors shall meet the visual requirements specified in appendix C.

3.15 Thermal shock and voltage conditioning. When tested as specified in 4.7.3, capacitors shall withstand the extremes of high and low temperature without visible damage and meet the following requirements within the percent defective allowed as specified in 4.6.3:

- a. Dielectric withstanding voltage (at 25° C): As specified in 3.10.
- b. Insulation resistance (at 25° C): Shall not be less than the initial requirement (see 3.5 and 3.11).
- c. Insulation resistance (at 125° C): Shall not be less than the initial requirement (see 3.5 and 3.11).
- d. Dissipation factor: Shall not exceed the value specified (see 3.5 and 3.9).
- e. Capacitance (at 25° C): Shall be within the tolerance specified (see 3.5 and 3.8).

Capacitance values no more than 5 percent or .5 picofarad (pF), whichever is greater, beyond the specified tolerance limit shall be removed from the lot but shall not be considered defective for determination of the percent defective allowed.

3.16 Solderability. When capacitors are tested as specified in 4.7.9 the immersed metallized surface shall be at least 90 percent covered with a new, smooth, solder coating. The remaining 10 percent may contain only small pinholes or rough spots; these shall not be concentrated in one area. Bare metal where the solder immersion failed to cover the original coating is an indication of poor solderability and shall be cause for failure. In case of dispute, the percent of coverage with pinholes or rough spots shall be determined by actual measurement of these areas, as compared to the total area.

## ML-PRF-31033

3.17 Resistance to soldering heat. When tested as specified in 4.7.10, capacitors shall meet the following:

- a. Insulation resistance at 25° C: Not less than the initial 25° C requirement (see 3.11).
- b. Capacitance: Shall not change more than -1.0 percent to +6.0 percent from the initial measured value.
- c. Dissipation factor: Shall not exceed the initial limits (see 3.9).

3.18 Voltage/temperature limits. When tested as specified in 4.7.11, the capacitance change over the specified temperature range shall not exceed the limits specified in table II. The capacitance value obtained in table VIII, step C shall be considered as the reference point.

TABLE II. Capacitance change with reference to +25° C.

Characteristic	Steps A through D of table VIII Bias = 0 volts	Steps E through G of table VIII Bias = rated voltage	Class
X7R/BX	±15 percent	+15, -25 percent	S
X7R/BR	±15 percent	+15, -40 percent	B, & C
COG/NP0	±30 ppm/° C	±30 ppm/° C	S, B, & C

3.19 Humidity, steady state, low voltage. When tested as specified in 4.7.12, capacitors shall meet the following requirements:

- a. Visual examination: No mechanical damage.
- b. Dielectric withstanding voltage: As specified in 3.10.
- c. Insulation resistance: Not less than 50 percent of the initial 25° C requirement specified in 3.11.
- d. Capacitance: Shall not change more than ±10 percent from the initial measured value.

3.20 Life (at elevated ambient temperature). When tested as specified in 4.7.13, capacitors shall meet the following requirements:  
1,000 hour limits:

- a. Insulation resistance: (at 125° C): Shall be not less than the initial requirement (see 3.11).
- b. Visual examination: No mechanical damage.
- c. Insulation resistance (at 25° C): Shall be not less than the initial requirement (see 3.11).
- d. Capacitance: Shall not change more than ±20 percent from the initial measured value.
- e. Dissipation factor: Shall not exceed 2.5 percent, or 0.15 percent for COG/NP0 characteristics.

3.21 Dielectric voltage breakdown. When tested as specified in 4.7.14, no failure shall occur. A failure is defined as a steady state current above 1 milliamper (mA).

3.22 Workmanship. Discoidal capacitors shall be processed in such a manner as to be uniform in quality and shall meet the requirements of 3.4, 3.5, 3.6 and all performance requirements. The discoidal capacitors shall pass the visual inspection criteria as specified in 4.7.2 and shall be free of other defects that will affect life, serviceability, or appearance.

## ML-PRF-31033

## 4. VERIFICATION

4.1 Classification of inspection. The inspections specified herein are classified as follows:

- a. Qualification inspection (see 4.5).
- b. In-process inspection (see 4.6).
- c. Group A conformance inspection (see 4.6.3).
- d. Group B inspection (see 4.6.4).

4.2 QML system elements. The manufacturers shall establish and maintain a system to meet MIL-STD-790 and requirements specified herein (see 3.3). Evidence of such compliance shall be verified by the qualifying activity of this specification as a prerequisite for qualification and continued qualification.

4.3 Statistical process control (SPC). A SPC program shall be established and maintained in accordance with EIA-557. Evidence of such compliance shall be verified by the qualifying activity of this specification as a prerequisite for qualification and continued qualification.

4.4 Inspection conditions and reference measurements.

4.4.1 Conditions. Unless otherwise specified herein, all inspections shall be performed in accordance with the test conditions specified in the "GENERAL REQUIREMENTS" of MIL-STD-202 except relative humidity shall not exceed 75 percent. Accuracy of all test voltage measurements shall be within  $\pm 2.0$  percent of the specified voltage.

4.4.2 Reference measurements. When requirements are based on comparative measurements made before and after conditioning, the reference measurement shall be considered the last measurement made at  $25^{\circ}\text{C} \pm 3^{\circ}\text{C}$  prior to conditioning. Unless reference measurements have been made within 30 days prior to the beginning of conditioning, they shall be repeated.

4.4.3 Power supply. The power supply used for life testing shall have a regulation of  $\pm 2$  percent or less of the specified test voltage.

4.5 Qualification inspection. Qualification inspection shall be performed at a laboratory acceptable to the qualifying agency on sample units produced with equipment and procedures normally used in production.

4.5.1 Sample size. The procedure for selection of representative discoidal capacitors and the number of capacitors to be specified for qualification inspection shall be as specified in table III and appendix A.

4.5.2 Test routine. Sample units shall be subjected to the tests specified in table III in the order shown. Sample units shall have been subjected to the in-process screening required by this specification and all sample units shall be subjected to the inspection of group I. The sample shall be divided as specified in table III as applicable.

4.5.3 Failures. Failures in excess of those allowed in table III shall be cause for refusal to grant qualification approval.

4.5.4 Verification of qualification.

4.5.4.1 Class C discoidal capacitors. To retain qualification, the manufacturer must maintain Class B qualification. If Class B qualification is removed for a range of capacitors, the qualification for the corresponding Class C range of capacitors is also removed.

4.5.4.2 Class B and Class S discoidal capacitors. Every 12 months the manufacturer shall provide verification of qualification to the qualifying activity. Continuation of qualification is based on meeting the following requirements:

- a. MIL-STD-790 system.
- b. Design of capacitor has not been modified.
- c. Group B inspections.

ML-PRF-31033

TABLE III. Qualification inspection, Class B and Class S.

Inspection	Requirement paragraph	Test method paragraph	Number of sample units to be inspected		Number of failures allowed <sup>1/</sup>	
			Class		Class	
			B	S	B	S
<u>Group I</u>						
Thermal shock and voltage conditioning	3.15	4.7.3	All sample units	All sample units	See 4.6.3	See 4.6.3
Dielectric withstanding voltage	3.10	4.7.6				
Insulation resistance at 25° C	3.11	4.7.7				
Insulation resistance at 125° C	3.11	4.7.7				
Capacitance	3.8	4.7.4				
Dissipation factor	3.9	4.7.5				
<u>Group II</u>						
Visual and mechanical inspection	3.7 and 3.14	4.7.2	5	10	}	0
Destructive physical analysis	3.12	4.7.8				
<u>Group III</u>						
Solderability	3.16	4.7.9	10	10	}	0
Resistance to soldering heat	3.17	4.7.10				
<u>Group IV</u>						
Voltage/temperature limits	3.18	4.7.11	10	10	}	0
Humidity, steady state, low voltage	3.19	4.7.12				
<u>Group V</u>						
Life	3.20	4.7.13	10	20	}	0

<sup>1/</sup> A sample unit having one or more defects will be charged as a single defective.

#### 4.6 In-process inspection.

4.6.1 In-process inspection. Each production lot of parts shall be inspected in accordance with table IV. The nondestructive internal examination shall be for Class S only. Other screening examinations may be applied at the option of the manufacturer, as approved by the qualifying activity.

4.6.1.1 Failure of parts/lots. Parts which fail the 100 percent screens are considered rejects and shall not be considered as conforming products. Lots which fail the dielectric voltage breakdown test may be rescreened, defects removed, and the lot resubmitted to the dielectric voltage breakdown test with a new sample. If the lot fails again, the lot is considered rejected. (NOTE: Dielectric voltage breakdown is a destructive test and samples shall not be supplied as conforming product).

ML-PRF-31033

TABLE IV. In-process inspection.

Inspection	Requirement paragraph	Test method paragraph	Sample size
Nondestructive internal examination (Class S only)	3.13	4.7.1	100%
Visual examination	3.14	4.7.2	100%
Dielectric voltage breakdown	3.21	4.7.14	Table IX, column "B"

#### 4.6.2 Inspection of product for delivery.

4.6.2.1 Class C products. Inspection of product for delivery shall consist of the manufacturer's normal in-house screens and inspections. These screens and inspections for Class C shall be verified in the MIL-STD-790 system (see 3.3).

4.6.2.2 Class B products. Inspection of product for delivery shall consist of group A inspection.

4.6.2.3 Class S products. Inspection of product for delivery shall consist of group A and group B inspections.

4.6.2.4 Class C inspection lot. An inspection lot shall consist of all discoidal capacitors of a single design, produced under essentially the same conditions, and offered for inspection at one time.

4.6.2.5 Class B inspection lot. An inspection lot shall consist of all discoidal capacitors of a single design, produced under essentially the same conditions, and offered for inspection at one time.

4.6.2.6 Class S inspection lot. An inspection/production lot shall be of one design. As a minimum requirement, the lot shall consist of all the capacitors of a single nominal capacitance/voltage rating of one design, from the same dielectric material batch, and processed as a single lot through all the manufacturing steps on the same equipment, and identified with the same date and lot code designation. The lot may contain all available capacitance tolerances for the nominal capacitance value. In addition, the lot shall conform to the following:

- a. Raw materials such as end terminations, ceramic raw materials, binders, and electrode ink shall be traceable to the same lot or batch and be from the same contractor.
- b. A lot number shall be assigned before electrode printing (inking) and be manufactured from the same slurry and cast on the same belt or comparable equipment.
- c. A single mix of a basic ceramic formulation fired through one kiln with one temperature profile during the process, with constant dielectric design, with, in general, no more than 20 percent variation in the number of active dielectrics being assembled in one continuous buildup. Sublots may be allowed to provide a spread in capacitance value to improve the yield. This will normally be done in the case of tight tolerances and low capacitance. In these circumstances, more than 20 percent variation in the number of active dielectrics may be required.
- d. End termination material shall be consistent in formulation and traceable to a single batch and shall be fired in the same kiln with no temperature adjustment during the process. All parts shall enter the kiln in one continuous operation/run for end termination firing.
- e. Lot identity shall be maintained from the time the lot is assembled to the time it is accepted.
- f. The lot date code (LDC) shall be recorded after firing and after end termination firing.



ML-PRF-31033

4.6.3 Group A conformance inspection (Class B and S only). Group A inspection shall consist of the tests specified in table V. Subgroup 1 tests shall be performed on 100 percent of the product supplied under this specification to the extent specified. Failure to meet PDA requirements shall cause the lot to be rejected. Unless otherwise specified, the PDA for Class B shall be 5 percent and the PDA for Class S shall be 3 percent. (Note: During the last 25 percent of the test cycle of voltage conditioning for Class S, the PDA shall not exceed 0.1 percent). For subgroup 2, a sample of parts from each inspection lot shall be randomly selected in accordance with column "A" of table IX. There shall be no failures allowed. For subgroup 3, a sample of parts from each inspection lot shall be selected at random in accordance with table VII. If the number of rejects exceed the number allowed in table VII, the sample shall be considered to have failed.

TABLE V. Group A inspection.

Inspection	Requirement paragraph	Test method paragraph	Sample size
<u>Subgroup 1</u>			
Thermal shock and voltage conditioning	3.15	4.7.3	100%
Dielectric withstanding voltage	3.10	4.7.6	100%
Insulation resistance at 25° C	3.11	4.7.7	100%
Insulation resistance at 125° C	3.11	4.7.7	100%
Capacitance	3.8	4.7.4	100%
Dissipation factor	3.9	4.7.5	100%
<u>Subgroup 2</u>			
Visual and mechanical examination: material, physical dimensions, design and construction, marking and workmanship	3.14, 3.22	4.7.2	See table IX, column "A"
<u>Subgroup 3</u>			
Destructive physical analysis	3.12	4.7.8	See table VII

4.6.4 Group B inspection (Class B and Class S only). Group B inspection shall consist of the tests specified in table VI in the order shown. For class B discoidal capacitors, the group B inspection shall be made on sample units selected at random from inspection lots which have passed group A inspection. The sample shall be representative of production for each nominal size produced. For class S discoidal capacitors, the group B inspection shall be performed on sample units selected at random from the inspection lot that has passed group A inspection.

#### 4.6.4.1 Sampling plan.

##### 4.6.4.1.1 Class B discoidal capacitors.

4.6.4.1.1.1 Semiannually. Every 6 months, 10 sample units of the highest capacitance value produced for each voltage rating shall be subjected to the tests of subgroup 1.

4.6.4.1.1.2 Annually. Every 12 months, 25 sample units of the highest capacitance value produced for each voltage rating shall be subjected to the tests of subgroup 2.

4.6.4.1.1.3 Annually. Every 12 months, 5 sample units of any capacitance value produced for each voltage rating shall be subjected to the tests of subgroup 3. Also, an additional 25 sample units of the highest capacitance value produced for each voltage rating shall be subjected to the test of subgroup 4.

## ML-PRF-31033

4.6.4.1.2 Class S discoidal capacitors. Samples shall be submitted for group B inspection in accordance with table VI. The samples shall be divided into groups as specified in table VI and subjected to the specified tests.

4.6.4.1.2.1 Life test. Samples of class S discoidal capacitors shall be subjected to the life test for every lot, or every 12 months if no production has occurred.

4.6.4.2 Failures. If the number of failures exceed the number allowed in table VI, the sample shall be considered to have failed.

4.6.4.3 Disposition of sample units. Sample units which have been subjected to group B inspection shall not be delivered on the contract or purchase order.

TABLE VI. Group B inspection.

Inspection	Requirement paragraph	Test method paragraph	Sample size		Accept/reject
			Class B	Class S	
<u>Subgroup 1</u> Humidity, steady state, low voltage	3.19	4.7.12	10	12	0
<u>Subgroup 2</u> Voltage/temperature limits	3.18	4.7.11	25	12	0
<u>Subgroup 3</u> Solderability Resistance to soldering heat	3.16 3.17	4.7.9 4.7.10	5	12	0
<u>Subgroup 4</u> Life	3.20	4.7.13	25	1/	2/ 0

1/ Sample size for Class S is as follows:

Lot size	Sample size
1 - 1,200	25
1,201 - 10,000	80

2/ For Class S: Sample size of 80, accept on 1 and reject on 2 defects.

4.6.5 Noncompliance. If a sample fails to pass group B inspection, the manufacturer shall immediately notify the qualifying activity and cognizant inspection activity of such failure and take corrective action on the materials or processes, or both, as warranted, and on all units of product which can be corrected and which were manufactured under essentially the same conditions, with essentially the same materials and processes, and which are considered subject to the same failure. Acceptance and shipment of the product shall be discontinued until corrective action, acceptable to the Government, has been taken. After the corrective action has been taken, group B inspection shall be repeated on additional sample units (all inspections, or the inspection which the original sample failed, at the option of the qualifying activity). Group A (and group B if applicable) inspection may be reinstated; however, final acceptance shall be withheld until the group B inspection has shown that the corrective action was successful. In the event of failure after inspection, information concerning the failure and corrective action taken shall be furnished to the cognizant inspection activity and the qualifying activity.

## ML-PRF-31033

4.7 Methods of inspection.4.7.1 Nondestructive internal examination (Class S only) (see 3.13).

4.7.1.1 Ultrasonic examination (see 3.13.1). When specified, capacitors shall be subjected to ultrasonic examination as specified in appendix B or, to some other nondestructive internal examination procedure as determined by the manufacturer and approved by the procuring activity (see 3.2).

4.7.2 Visual Examination (see 3.14). Capacitors shall be examined under magnification as specified in appendix C and shall meet the visual requirements of appendix C.

4.7.3 Thermal shock and voltage conditioning (see 3.15). Capacitors shall be subjected to the tests of 4.7.3.1 and 4.7.3.2.

4.7.3.1 Thermal shock (see 3.15). Capacitors shall be tested in accordance with method 107 of ML-STD-202. The following details shall apply:

- a. Test condition A, except that in step 3, sample units shall be tested at +125° C.
- b. For qualification testing: 100 cycles of thermal shock.
- c. For group A testing: Class S - 20 cycles of thermal shock; Class B - 5 cycles of thermal shock.

4.7.3.2 Voltage conditioning (see 3.15). Class S and Class B capacitors shall be tested in accordance with 4.7.3.2.1 or 4.7.3.2.2. The lot traveler shall indicate which test is used. When the optional voltage conditioning test of 4.7.3.2.2 is used, the traveler shall include the specific accelerated voltage used and the test time (see figure 1).

4.7.3.2.1 Standard voltage conditioning. Voltage conditioning shall be started after completion of the thermal shock test. The voltage conditioning shall consist of applying twice the rated voltage to the units at the maximum rated temperature of 125° C +4° C, -0° C, for a minimum of 168 hours and a maximum of 264 hours for Class S product, and 164 hours ±4 hours for Class B product. The voltage conditioning for Class S capacitors may be terminated at any time during the 168 hour to 264 hour time interval provided that failures (blown fuses or less than 95 percent voltage) do not exceed 0.1 percent or one unit during the last 48 hours. Voltage shall be applied and shall reach maximum value within one second, maximum. To assure that at least 95 percent of the applied test voltage is maintained for the duration of the exposure period, the circuit on figure 1 shall be used. After completion of the exposure period, the unit shall be allowed to stabilize at room temperature (25° C) (for no more than one hour). After stabilization at room temperature, the dielectric withstanding voltage and insulation resistance shall be measured as specified in 4.7.6 and 4.7.7, respectively. After measurement of dielectric withstanding voltage and insulation resistance at 25° C, the unit shall be stabilized at maximum rated temperature and insulation resistance measured. After allowing the unit to stabilize at room temperature for 10 hours minimum, the capacitance and dissipation factor shall be measured as specified in 4.7.4 and 4.7.5, respectively. If the voltage conditioning test is performed with individual fuses in series with each part, any part tested in a position where a fuse fails shall be tested for insulation resistance and dielectric withstanding voltage. If the part meets the initial requirements for insulation resistance and dielectric withstanding voltage, the part shall be rejected but shall not be counted against the percent defective allowed.

4.7.3.2.2 Optional voltage conditioning. The manufacturer, with approval from the qualifying activity, may perform an optional voltage conditioning test instead of the standard voltage conditioning test of 4.7.3.2.1. All conditions of 4.7.3.2.1 apply, with the exception of the voltage applied and test time. The minimum time duration,  $T_{(test)}$ , shall be calculated as follows:

$$T_{(test)} = \frac{1344}{(E_{(test)}/E_{(rated)})^3}$$

Where:  $2 \times E_{rated} \leq E_{test} \leq 4 \times E_{rated}$

$T_{(test)}$  = Minimum test time in hours  
 $E_{(test)}$  = Applied voltage  
 $E_{(rated)}$  = Rated voltage of the capacitor

NOTE: This optional voltage conditioning test may not be used on capacitors with voltage ratings greater than 200 volts.

## ML-PRF-31033

4.7.4 Capacitance (see 3.8). Capacitors shall be tested in accordance with method 305 of MIL-STD-202. The following details and exceptions shall apply:

- a. Test frequency: 1 Mhz  $\pm$ 100 KHz when the nominal capacitance is 100 pF or less, and 1 KHz  $\pm$ 100 Hz when the nominal capacitance is greater than 100 pF.
- b. Voltage: A root-mean-square potential (RMS) of 1.0 volt  $\pm$ 0.2 volt for 1 KHz measurements and less than 1.0 volt for 1 Mhz measurements.

NOTE: Following a dielectric withstanding voltage or insulation resistance test, capacitance measurement may be delayed for a period of up to 24 hours.

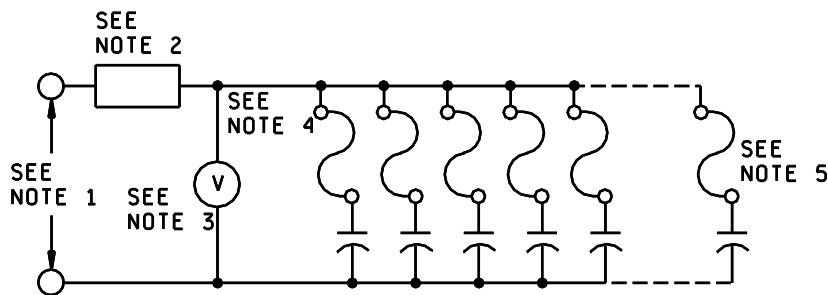

## NOTES:

1. The power supply shall be capable of providing a minimum of twice the rated voltage of the capacitors at a fault current of 30 mA minimum.
2. The current limiting device shall be a resistor and/or a fuse. The current shall be limited to no less than 30 mA and no more than 10 A.
3. There shall be a voltage monitor that will trigger an alarm and shut off the test if the applied voltage drops by more than 5 percent.
4. Fuses shall be optional and resistors shall not be allowed. If fuses are used, the total resistance of the fuse, connections, and the connecting wires shall not exceed 50 ohms at +125° C.
5. The capacitor bank shall be no less than 10.

FIGURE 1. Voltage conditioning circuitry.

4.7.5 Dissipation factor (see 3.9). The dissipation factor shall be measured with a capacitance bridge or other suitable method at the frequency and voltage specified in 4.7.4. The inherent accuracy of the measurement shall be  $\pm$ 2 percent of the reading plus 0.1 percent dissipation factor (absolute) unless otherwise specified. Suitable measurement techniques shall be used to minimize errors due to the connections between the measuring device and the capacitor.

4.7.6 Dielectric withstanding voltage (see 3.10). Capacitors shall be tested in accordance with method 301 of MIL-STD-202. The following details shall apply:

- a. Magnitude and nature of test voltage: 250 percent of the dc rated voltage.
- b. Duration of application of test voltage: 5 seconds  $\pm$ 1 second. The test voltage shall be raised from zero to the specified value within 1 second, maximum.
- c. Points of application of test voltage: Between the capacitor element terminals.
- d. Limiting value of surge current: Shall be limited between 30 mA and 50 mA.
- e. Examination after test: Capacitors shall be examined for evidence of damage or breakdown.

## ML-PRF-31033

4.7.7 Insulation resistance (see 3.11). Capacitors shall be tested in accordance with method 302 of MIL-STD-202. The following details shall apply:

- a. Test potential: Rated voltage.
- b. Special conditions: If failure occurs at a relative humidity above 50 percent, the insulation resistance may be measured again at any relative humidity less than 50 percent.
- c. Points of measurements: Between the inner and outer terminations.

4.7.8 Destructive physical analysis (see 3.5, 3.6, and 3.12). Capacitors shall be examined as specified in EIA Standard RS-469, 4.7.8a through 4.7.8m, inclusive, and in accordance with table VII.

- a. Chipping of termination edge (see figure 2A) shall be cause for rejection if it will hinder uniform metallization or if it extends to or is near (within 0.076 mm (3 mils)) an electrode plate.
- b. Number of electrodes shall correspond to the electrode number specified for each lot. Variation of number of electrodes shall be acceptable from lot to lot.
- c. Thin covers less than 0.076 mm (3 mils) are cause for rejection.
- d. Borders or edges (see figure 2B) that are less than 0.076 mm (3 mils) from a plate shall be cause for rejection.
- e. Electrode shorts (see figure 2C) shall be cause for rejection.
- f. Dielectric thickness shall not vary by more than  $\pm 50$  percent of its mean thickness on any single layer (see figure 2D).
- g. Curvature in the electrodes are permitted provided the dielectric thickness is not decreased at any point by more than 20 percent (see figure 2E).
- h. Discontinuities in the electrodes, if not by design, shall not extend to more than 20 percent of the section (see figure 2F).
- i. Pinholes and voids are permitted as long as they are not greater than 0.051 mm (2 mils) in diameter, and do not cover more than 5 percent of the cross-section.
- j. Isolated electrodes or electrode fragments connected to the termination are not to be subject to rejection if separated from other active conductors by at least the nominal dielectric thickness of that capacitor design (see figure 2G).
- k. Delaminations and defects within the active area of the electrodes shall not exceed 30 percent of the active length of the electrodes or 0.254 mm (10 mils), whichever is greater, and shall not reduce the dielectric more than 50 percent. No more than three such defects shall appear in a single capacitor examined.
- l. Delaminations shall be permitted in the margin area (see figure 2H).
- m. There shall be contact between the electrodes and the metallization.

TABLE VII. Destructive physical analysis sample sizes.

Lot size	Minimum sample size		Accept		Reject	
	Class S	Class B	Class S	Class B	Class S	Class B
1 - 500	14	7	0	0	1	1
501 - 1,200	20	10	1	0	2	1
1,201 - 10,000	32	16	2	0	3	1

## MIL-PRF-31033

4.7.9 Solderability (see 3.16). Capacitors shall be tested in accordance with method 208 of MIL-STD-202. The following details and exceptions shall apply:

- a. Solder shall be Pb36 in accordance with ANSI/J-STD-006.
- b. Each capacitor shall be completely immersed.
- c. The method of attaching the capacitor to the dipping apparatus shall be so designed as to expose 100 percent of the inner termination and 100 percent of the outer termination.
- d. Examination of terminations shall be in accordance with 3.16.

4.7.10 Resistance to soldering heat (see 3.17). Capacitors shall be tested in accordance with method 210 of MIL-STD-202. The following details shall apply:

- a. Test condition B, except the solder temperature shall be  $230^{\circ}\text{C} +5^{\circ}\text{C}$ ,  $-0^{\circ}\text{C}$  and the duration shall be 5 seconds +1 second, -0 second. Each capacitor shall be completely immersed twice.
- b. Cooling time prior to measurement after test: 10 minutes minimum and up to 24 hours maximum.
- c. Measurements before test: Capacitance, dissipation factor, and insulation resistance at  $25^{\circ}\text{C}$  shall be measured and recorded as specified in 4.7.4, 4.7.5, and 4.7.7, respectively.
- d. Measurement after test: Capacitance, dissipation factor, and insulation resistance at  $25^{\circ}\text{C}$  shall be measured and recorded as specified in 4.7.4, 4.7.5, and 4.7.7, respectively.

4.7.11 Voltage-temperature limits (see 3.18). The temperature of each capacitor shall be varied as specified in table VIII. Capacitance measurements shall be made at the frequency and voltage specified in 4.7.4. The dc rated voltage specified in table VIII shall be maintained on the capacitor during step E to step G inclusive. Capacitance measurements shall be made at each step specified in table VIII and at five intermediate temperatures between step B and step G to establish a true characteristic curve. Capacitors shall be kept at each temperature until temperature equilibrium is attained.

4.7.11.1 Voltage-temperature limits for quality conformance inspection. Capacitance measurements shall be made only for steps C, D, E, and G of table VIII.

TABLE VIII. Voltage-temperature limit cycle.

Step	Voltage, dc	Temperature °C
A	None	+25 ±2
B	None	-55 ±2
C <sup>1/</sup>	None	+25 ±2
D	None	+125 ±2
E	Rated	+125 ±2
F	Rated	+25 ±2
G	Rated	-55 ±2

<sup>1/</sup> Reference point.

ML-PRF-31033

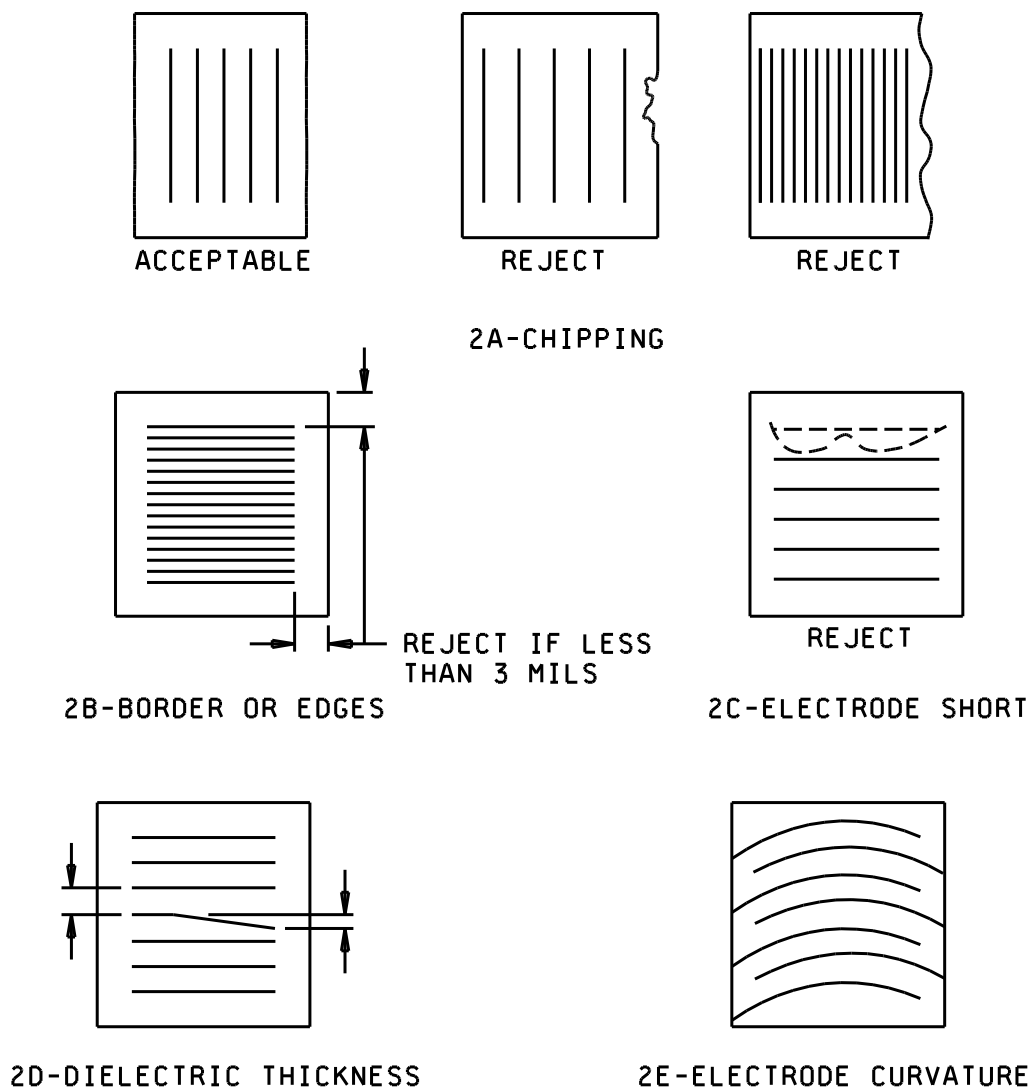

FIGURE 2. Sectioned capacitors (only one side of discoidal is shown).

ML-PRF-31033

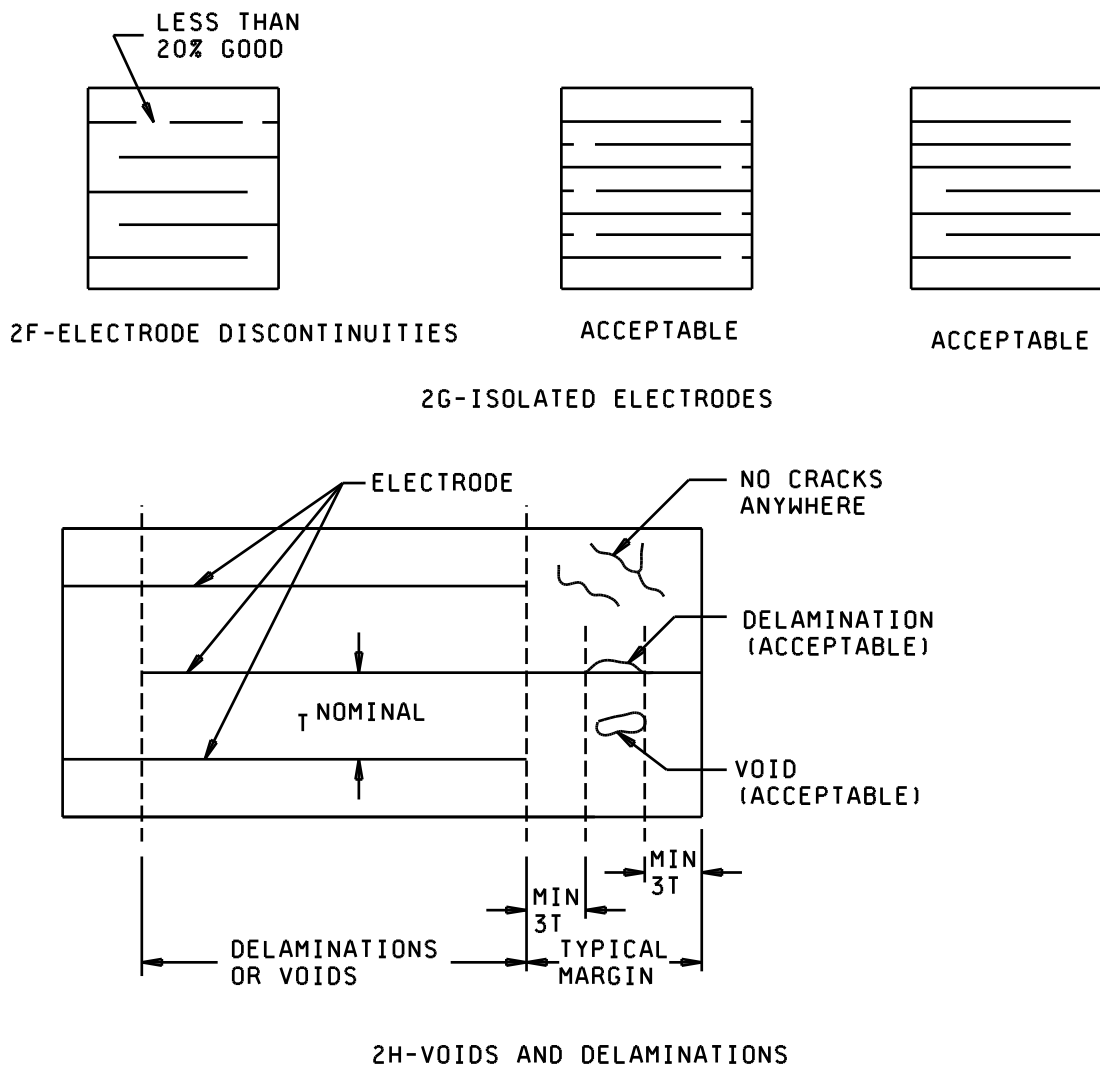

FIGURE 2. Sectioned capacitors (only one side of discoidal is shown) - Continued.



## ML-PRF-31033

4.7.12 Humidity, steady state, low voltage (see 3.19). Capacitors shall be tested in accordance with method 103, test condition A of MIL-STD-202. The following details and exceptions shall apply:

NOTE: At no time during test shall voltage greater than 1.5 volts be applied to any capacitor under test.

- a. Initial measurements: Capacitance.
- b. Tests: Capacitors shall be subjected to an environment of 85° C with 85 percent humidity for 240 hours minimum. Cycling shall not be performed. A dc potential of 1.3 volts  $\pm 0.25$  volts maximum shall be applied continuously through a 100 kilohm resistor to each device under test.
- c. Final measurements: - Upon completion of above tests, remove capacitors from chamber and allow to dry and stabilize at 25° C before performing measurements for capacitance, dissipation factor, and insulation resistance through a 100 kilohm resistor at 1.5 volts maximum, in accordance with 3.8, 3.9, and 3.11.
- d. Visual examination: - After final measurements, the capacitor shall be examined for evidence of mechanical damage and obliteration of marking.

4.7.13 Life (at elevated ambient temperature) (see 3.20). Capacitors shall be tested in accordance with method 108 of MIL-STD-202. The following details and exceptions shall apply:

- a. Distance of temperature measurements from specimens is not applicable.
- b. Test temperature tolerance: +125° C +4° C, -0° C.
- c. Capacitors shall be subjected to the voltage and circuit specified in 4.7.3.2.
- d. Test duration: 1,000 hours.
- e. Measurements during and after exposure: At the conclusion of 1,000 hours and while the capacitors are at the applicable high-test temperature, the insulation resistance shall be measured as specified in 4.7.7. At the option of the manufacturer, the units may be immediately transferred (period of transfer not to exceed 15 minutes) to another chamber maintained at the same temperature for the purpose of measuring the insulation resistance. The insulation resistance measurement shall be made only after the units have stabilized at the test temperature. The capacitors shall then be returned to the inspection conditions specified in 4.4 and shall be visually examined for evidence of mechanical damage; capacitance, dissipation factor, and insulation resistance shall be measured as specified in 4.7.4, 4.7.5, and 4.7.7.

4.7.14 Dielectric voltage breakdown (see 3.21). Each discoidal capacitor in the sample shall be placed in an oil (or other suitable dielectric fluid) bath and connected in series with an instrument to measure current (must be able to measure mA). A dc voltage shall be gradually applied at no greater than 50 volts per second until failure occurs. A failure is defined as a steady state current above 1 mA. No failure shall occur at an applied voltage of less than 6X rated voltage or 1,200 V dc, whichever is less.

ML-PRF-31033

TABLE IX. C = 0 sampling plan. <sup>1/</sup> <sup>2/</sup>

Lot size	Sample size	
	A	B
2 to 15	*	5
16 to 50	20	5
51 to 90	20	7
91 to 150	20	11
151 to 280	20	13
281 to 500	47	16
501 to 1,200	47	19
1,201 to 3,200	53	23
3,201 to 10,000	68	29
10,001 to 35,000	77	35
35,001 to 150,000	96	40

<sup>1/</sup> \* Indicates entire lot must be inspected.

<sup>2/</sup> The acceptance number in all cases is zero.

## 5. PACKAGING

5.1 Packaging. For acquisition purposes, the packaging requirements shall be as specified in the contract or order (see 6.2). When actual packaging of materiel is to be performed by DoD personnel, these personnel need to contact the responsible packaging activity to ascertain requisite packaging requirements. Packaging requirements are maintained by the Inventory Control Point's packaging activity within the Military Department or Defense Agency, or within the Military Department's System Command. Packaging data retrieval is available from the managing Military Department's or Defense Agency's automated packaging files, CD-ROM products, or by contacting the responsible packaging activity.

## 6. NOTES

(This section contains information of a general or explanatory nature that may be helpful, but is not mandatory.)

6.1 Intended use. The discoidal capacitors described in this specification are primarily intended for use in EM/RFI filters covered by MIL-PRF-28861.

6.2 Acquisition requirements. Acquisition documents must specify the following:

- a. Title, number, and date of this specification.
- b. Issue of DoDISS to be cited in the solicitation, and if required, the specific issue of individual documents referenced (see 2.2).
- c. Engineering item requirements (see 6.4).
- d. Packaging requirements (see 5.1).

6.3 Qualification. With respect to products requiring qualification, awards will be made only for products which are, at the time of award of contract, qualified for inclusion in Qualified Manufacturer's List (QML) whether or not such products have actually been so listed by that date. The attention of the contractors is called to these requirements, and manufacturers are urged to arrange to have the products that they propose to offer to the Federal Government tested for qualification in order that they may be eligible to be awarded contracts or orders for the products covered by this specification. Information pertaining to qualification of products may be obtained from Defense Supply Center Columbus (DSCC-VQP), 3990 East Broad Street, Columbus, OH 43216-5000.

6.3.1 Copies of SD-6. Copies of SD-6, "Provisions Governing Qualification", may be obtained upon application to Defense Printing Service Detachment Office, Bldg. 4D (Customer Service), 700 Robbins Avenue, Philadelphia, PA 19111-5094.

ML-PRF-31033

6.4 Engineering item requirements. Engineering item requirements should specify the following:

- a. Product level.
- b. Capacitance value.
- c. Capacitance tolerance.
- d. Outer diameter.
- e. Voltage rating.
- f. Dissipation factor.
- g. VTL characteristic (e.g. - X7R/BX; X7R/BR; or C0G/NP0).

6.5 Definitions. The following terms have been used in this specification and are defined as stated herein.

6.5.1 Chip (see figure 3A). Any place where material has been removed as a result of a fracture.

6.5.2 Crack (see figure 3B). Any fissure or parting of the material.

6.5.3 Delamination (see figure 3G). The separating of capacitor layers.

6.5.4 Etching (see figure 3E). Thin markings or lines in a surface.

6.5.5 Metallization (see figure 3H). A palladium silver, silver, or solder coated termination.

6.5.6 Pinhole (see figure 3F). A minuscule circular hollow or cavity in a body no larger than 0.051 mm (2 mils) in diameter and no deeper than 0.051 mm (2 mils).

6.5.7 Ripple (see figure 3D). A wave in a surface; defined as being 0.076 mm (3 mils) or more in amplitude and 0.025 mm (1 mil) or more in width.

6.5.8 Striation (see figure 3C). Thin grooves, channels, or lines running in or on the surface of the body.

6.6 Subject term (key word) listing.

Capacitance  
EMI  
Filter  
RFI  
QML

6.7 Changes from previous issue. Marginal notations are not used in this revision to identify changes with respect to the previous issue due to the extent of the changes.

ML-PRF-31033

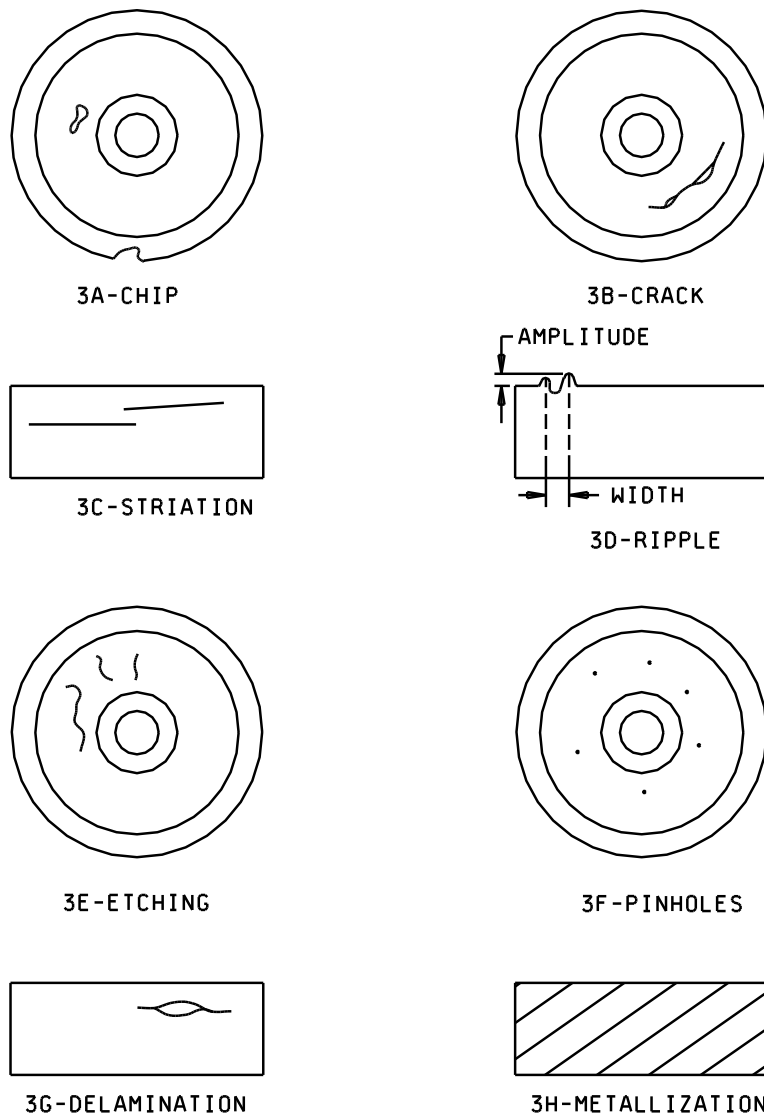

FIGURE 3. Definitions.

## ML-PRF-31033

## APPENDIX A

## PROCEDURE FOR QUALIFICATION

## A.1 SCOPE

A.1.1 Scope. This appendix details the procedure for manufacturers to follow in becoming a qualified manufacturer to this specification. The procedure requires demonstration of manufacturing capability for building discoidal capacitors and the submission of representative discoidal capacitor designs to the qualification tests. This appendix is a mandatory part of this specification. The information contained herein is intended for compliance.

A.2 APPLICABLE DOCUMENTS. This section is not applicable to this appendix.

## A.3 PROCEDURE

A.3.1 Submission and qualification of discoidal capacitor manufacturing capability. In order to be evaluated on the capability to manufacture discoidal capacitors to meet the requirements of this specification, including the requirements of 3.5, the manufacturer shall submit samples of discoidal capacitors to the tests of table III and table IV. The sample of discoidal capacitors shall be selected in accordance with A.3.1.1 and A.3.1.2.

A.3.1.1 Initial qualification of a single design. For initial qualification of a single design (nominal outer diameter size), the following is required:

- a. Class B: 35 pieces of the highest voltage and highest capacitance and 35 pieces of the lowest voltage and highest capacitance will be submitted to the qualification tests of table III.
- b. Class S: 50 pieces of the highest voltage and highest capacitance and 50 pieces of the lowest voltage and highest capacitance will be submitted to the qualification tests of table III.

A.3.1.2 Initial qualification to a range of sizes. For initial qualification to a range of sizes, the following is required:

- a. Class B: For the largest nominal outer diameter size for which qualification is sought, 35 pieces of the highest voltage and highest capacitance and 35 pieces of the lowest voltage and highest capacitance will be submitted to the qualification tests of table III. For the smallest nominal outer diameter size for which qualification is sought, 35 pieces of the highest voltage and highest capacitance and 35 pieces of the lowest voltage and highest capacitance will be submitted to the qualification tests of table III.
- b. Class S: For the largest nominal outer diameter size for which qualification is sought, 50 pieces of the highest voltage and highest capacitance and 50 pieces of the lowest voltage and highest capacitance will be submitted to the qualification tests of table III. For the smallest nominal outer diameter size for which qualification is sought, 50 pieces of the highest voltage and highest capacitance and 50 pieces of the lowest voltage and highest capacitance will be submitted to the qualification tests of table III.

## A.4 QUALIFIED MANUFACTURER LIST (QML)

A.4.1 QML listing. Upon successful completion of the requirements of A.3, the manufacturer shall notify the qualifying activity regarding listing of manufacturing capability on the QML. The following categories of capability should be addressed:

- a. Nominal outer diameter size.
- b. Voltage rating(s).
- c. The range of capacitance values available and the capacitance tolerance.
- d. Voltage temperature limits of capacitance.

For those instances where a range of sizes have been qualified, the manufacturer shall submit the maximum and minimum values for A.4.1a. and A.4.1c. for each rated voltage in A.4.1b.

## ML-PRF-31033

## APPENDIX B

## NONDESTRUCTIVE PHYSICAL ANALYSIS

## B.1 SCOPE

B.1.1 Scope. This appendix specifies the procedures for the nondestructive internal examination of Class S discoidal ceramic capacitors. The test procedure for ultrasonic examination is included. This appendix is a mandatory part of the specification. The information contained herein is intended for compliance only.

B.2 APPLICABLE DOCUMENTS. This section is not applicable to this appendix.

## B.3 ULTRASONIC EXAMINATION TEST METHODS AND REQUIREMENTS

B.3.1 Equipment. The test equipment shall be in accordance with the list below or its equivalent.

- a. Ultrasonic scanner US540 series. \*
- b. Pulser/receiver unit model 50S. \*
- c. Lab scanner model 450. \*
- d. 25 Mhz Transducer model 57 AH006. \*
- e. Sectioning equipment in accordance with EIA Standard RS-469.
- f. Plexiglass or glass tray.
- g. Capacitors known to be good (absence of delamination and cracks).
- h. Capacitors known to be defective (with delaminations).

\* Manufactured by Automation Industries Inc., Sperry Products Division, Subsidiary of General Cable.

B.3.2 Requirements. Capacitors determined to be good after testing and when sectioned in accordance with 4.7.2 must meet the destructive physical analysis requirements of 4.7.8.

B.3.2.1 Lots tested. Only one production lot of parts shall be scanned at one time.

B.3.2.2 Calibration samples. Two previously determined bad capacitors of the same dielectric material and size of the parts under test shall be added to the lot for testing.

B.3.3 Initial setup procedure. The initial setup procedure is as follows:

- a. Equipment shall be turned on and warmed up for 15 minutes, minimum.
- b. The tank shall have a water depth of 152.4 mm  $\pm$ 6.35 mm (6 inches  $\pm$ 0.250 inch), 175 ml  $\pm$ 5 ml of wetting agent shall be added to the tank.
- c. Capacitors shall be placed in identifiable rows on the plexiglass or glass tray and shall not be touching each other. The tray must be level and perpendicular to the transducer head axis. The tray shall be checked after it is in the tank to ensure no air bubbles are trapped under the capacitors, tray, or between the capacitors themselves.

B.3.4 Operating procedures. The discoidal image return and gate alarm setting shall be adjusted each time the equipment is turned off and on during the first tray of capacitors to be scanned per lot. Adjustments shall be in accordance with the test facility's operating instructions. The adjustments shall clearly confirm the good and bad calibration samples. These parts shall be easily identifiable from the remainder of the lot under test.

B.3.5 Qualification. Each test facility shall have a responsible person who has successfully completed a nondestructive testing course given by the manufacturers of the ultrasonic equipment. The ultrasonic test equipment shall not be operated by anyone who has not been certified and instructed in the use of ultrasonic testing by the designated person. The responsible person shall prepare a test method that describes the general procedures, requirements, and techniques for ultrasonic scanning of ceramic discoidal capacitors.

ML-PRF-31033

APPENDIX B

B.3.6 Equipment usage. Testing shall be done in accordance with the test equipment manufacturer's instructions and the test facility's operating procedures. The tank must be completely drained, cleaned, and refilled, at least once a month. NOTE: Anytime the tank is drained and refilled, the transducer lens must be checked to ensure that bubbles have not been trapped.

- a. The scanners (xy recorder) shall be activated and the printout of the calibration samples shall be compared against the scanner's "O" scope. If correlation for the calibration samples is obtained with the setting of B.3.4, the entire lot can be scanned with that setting.
- b. Any questionable scope results shall reject the capacitor under question.

## ML-PRF-31033

## APPENDIX C

## VISUAL INSPECTION CRITERIA FOR DISCOIDAL CAPACITORS

## C.1 SCOPE

C.1.1 Scope. This appendix specifies the visual inspection criteria for discoidal capacitors. This appendix is a mandatory part of the specification. The information contained herein is intended for compliance only.

C.2 APPLICABLE DOCUMENTS. This section is not applicable to this appendix.

## C.3 TEST EQUIPMENT

C.3.1 Apparatus. The apparatus for this inspection shall include optical equipment capable of 10 power magnification and any other visual standards (gauges, drawings, photographs, etc.) necessary to perform an effective examination.

## C.4 INSPECTION

C.4.1 Procedure. The device shall be examined under 10 power magnification to determine compliance with the requirements specified herein. The order in which criteria is presented is not a required order of examination of the terminations prior to sectioning. The samples shall be sectioned perpendicular to the plate surface to expose the internal electrodes. If a visual inspection requirement is in conflict with the detail standard, the latter shall govern.

C.4.1.1 Rejection criteria. Devices that deviate from the material, design, or construction requirements specified or exhibit any of the following defects shall be unacceptable.

C.4.1.1.1 Termination metallization (silvering or soldering).

- a. End terminals shall be 80 percent covered with metallization.
- b. Pinholes (figure 4A) shall not cover more than 5 percent of metallization or be larger than 0.127 mm (0.005 inch) in diameter.
- c. There shall be no cracks in the metallization.
- d. The inside edge of metallization (see figure 4B) shall be separated from the opposite termination metallization by a minimum of one third the total radius of the discoidal.
- e. Overlap (see figure 4C) shall be continuously smooth, without sharp points greater than one third the unmetallized radius.
- f. Gaps in the overlap (see figure 4D) shall not exceed 10 percent of the overlap area.
- g. Buildup of overlap (see figure 4E) shall not exceed 0.254 mm (.01 inch) (10 mils).
- h. There shall be no lifting of the metallization (see figure 4F).
- i. The overlap shall be as specified.
- j. There shall be no foreign material adhering to the solder.
- k. Metallized edges shall not be reduced to less than 90 percent due to chipping or the metallization process.



ML-PRF-31033

APPENDIX C

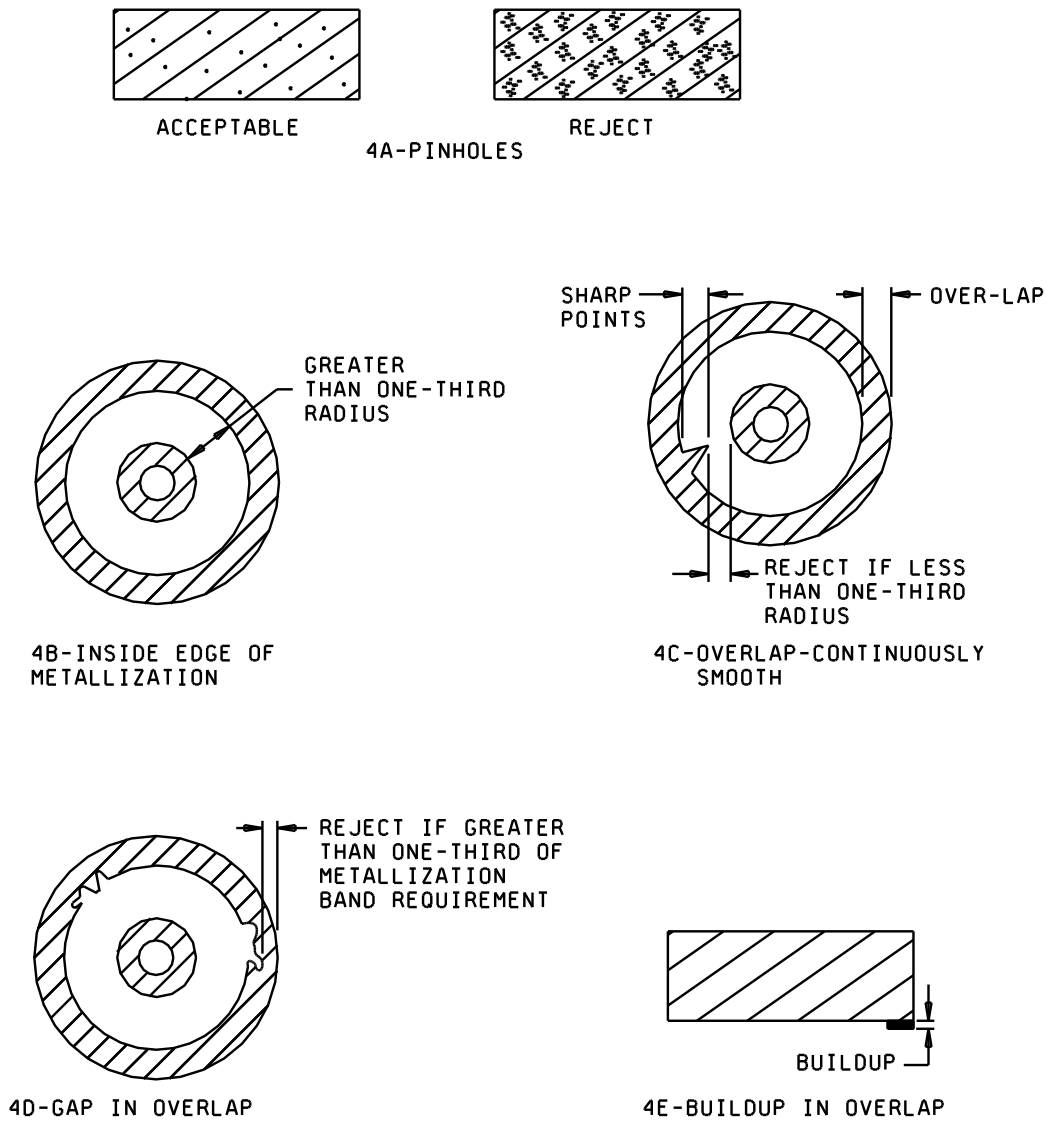
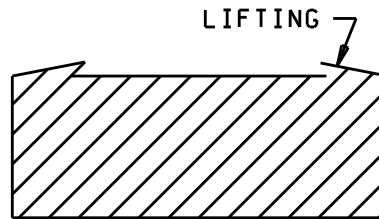

FIGURE 4. Termination metallization inspection.

ML-PRF-31033

APPENDIX C



**4F - METALLIZATION  
BAND LIFTING**

FIGURE 4. Termination metallization inspection - Continued.

C.4.1.1.2 Capacitor surface examination (after termination).

- a. There shall be no cracks in the capacitor body.
- b. No chips shall be greater than 0.254 mm (.01 inch) (10 mils) in diameter or deeper than 0.076 mm (.003 inch) (3 mils); these chips shall not cover more than 20 percent of a surface. No internal electrode shall be exposed through the cover.
- c. Rough or finely chipped edges are not permitted (see figure 2A).
- d. Fused dust or excess material on cover which prevents a capacitor from lying flat shall be cause for rejection. Lumps, burrs, fused cutting dust, or excess dielectric material shall not be greater than 0.127 mm (.005 inch) (5 mils) in diameter and may not protrude more than 0.254 mm (.01 inch) (10 mils) out of surface; they shall not cover more than 20 percent of a surface.
- e. Indications of bubbles in dielectric material (such as circular shadows) shall be cause for rejection.
- f. Striations are unacceptable.
- g. Warpage, exceeding 0.127 mm (.005 inch) (5 mils), or twisting of body shall be cause for rejection.
- h. Pinholes shall not cover more than 10 percent of the surface (see figure 5) and be no larger than 0.051 mm (0.002 inches) in diameter.
- i. Etching in a cover is permitted provided it does not exceed in depth more than 0.076 mm (.003 inch) (3 mils).
- j. A uniform rough surface is permitted provided that it cannot be identified as a collection of ripples.
- k. There shall be no delamination of dielectric layers.

ML-PRF-31033

APPENDIX C

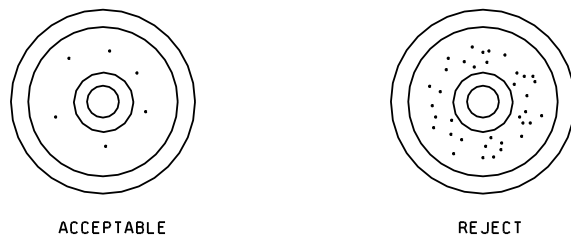

FIGURE 5. Pinholes.

ML-PRF-31033

CONCLUDING MATERIAL

Custodians:

Army - CR  
Navy - EC  
Air Force - 85  
NASA - NA

Preparing activity:  
DLA - ES

(Project 5910-1889)

Review activities:

Army - AR, AT, AV, ME, MI  
Navy - AS, CG, MC, OS, SH  
Air Force - 17, 19, 99

## STANDARDIZATION DOCUMENT IMPROVEMENT PROPOSAL

### INSTRUCTIONS

1. The preparing activity must complete blocks 1, 2, 3, and 8. In block 1, both the document number and revision letter should be given.
2. The submitter of this form must complete blocks 4, 5, 6, and 7.
3. The preparing activity must provide a reply within 30 days from receipt of the form.

NOTE: This form may not be used to request copies of documents, nor to request waivers, or clarification of requirements on current contracts. Comments submitted on this form do not constitute or imply authorization to waive any portion of the referenced document(s) or to amend contractual requirements.

I RECOMMEND A CHANGE:

1. DOCUMENT NUMBER  
MIL-PRF-31033

2. DOCUMENT DATE (YYMMDD)  
960809

3. DOCUMENT TITLE

CAPACITORS, FIXED, CERAMIC DIELECTRIC, HIGH RELIABILITY, DISCOIDAL, GENERAL SPECIFICATION FOR

4. NATURE OF CHANGE (Identify paragraph number and include proposed rewrite, if possible. Attach extra sheets as needed.)

5. REASON FOR RECOMMENDATION

6. SUBMITTER

a. NAME (Last, First, Middle initial)

b. ORGANIZATION

c. ADDRESS (Include Zip Code)

d. TELEPHONE (Include Area Code)

7. DATE SUBMITTED  
(YYMMDD)

(1) Commercial

(2) AUTOVON  
(If applicable)

8. PREPARING ACTIVITY

a. NAME

DEFENSE SUPPLY CENTER COLUMBUS

b. TELEPHONE (Include Area Code)

(1) Commercial (2) AUTOVON  
(614) 692-0562 850-0562

c. ADDRESS (Include Zip Code)

DEFENSE SUPPLY CENTER COLUMBUS  
3990 EAST BROAD STREET  
COLUMBUS, OH 43216-5000

IF YOU DO NOT RECEIVE A REPLY WITHIN 45 DAYS, CONTACT:

Defense Quality and Standardization Office  
5203 Leesburg Pike, Suite 1403, Falls Church, VA 22041-3466  
Telephone (703) 756-2340 AUTOVON 289-2340