

INCH-POUND

MIL-PRF-39015E
w/ Amendment 2
12 April 2016
SUPERSEDING
MIL-PRF-39015E
w/ Amendment 1
28 January 2011

PERFORMANCE SPECIFICATION

RESISTOR, VARIABLE, WIRE WOUND, (LEAD SCREW ACTUATED), NONESTABLISHED RELIABILITY, AND ESTABLISHED RELIABILITY, GENERAL SPECIFICATION FOR

This specification is approved for use by all Departments
and Agencies of the Department of Defense.

1. SCOPE

1.1 Scope. This specification covers the general requirements for nonestablished reliability (non-ER) and established reliability (ER), lead screw actuated; wire wound variable resistors with a contact bearing uniformly over the surface of the entire resistive element, wound linearly, when positioned by a multiturn lead screw actuator. These resistors are capable of full load operation (when the maximum resistance is engaged), at a maximum temperature of 85°C and are capable for continuous operation, when properly derated, at maximum temperature of 150°C (see 3.6), with a resistance tolerance of ± 5 percent. The ER resistors have life failure rate (FR) levels ranging from 1.0 percent to 0.001 percent per 1,000 hours (see 1.2.1.4). These FR levels are established at a 60 percent confidence level on the basis of life tests.

1.2 Classification.

1.2.1 Part or Identifying Number (PIN). Resistors specified herein are identified by the PIN which consists of the basic number, associated specification, and a coded number.

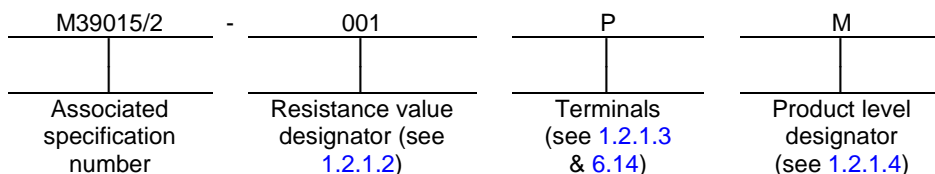

1.2.1.1 Style. The style is identified by the three-letter symbol "RTR" followed by a two-digit number; the letters identify lead screw actuated, wire wound, variable resistors, and the number identifies the physical size.

1.2.1.1.1 Performance requirements. The performance requirements are identified in accordance with table 1.

1.2.1.2 Resistance value designator. The resistance value designator is a coded value which identifies the resistance value, maximum resolution, and maximum rated working voltage (see 3.1).

Comments, suggestions, or questions on this document should be emailed to usarmy.apg.rdecom-cerdec.mbx.standardization-crx@mail.mil. Since contact information can change, you may want to verify the currency of this address information using the ASSIST Online database at <https://assist.dla.mil>.

AMSC N/A
DISTRIBUTION STATEMENT A. Approved for public release; distribution is unlimited.

FSC 5905



MIL-PRF-39015E
w/ Amendment 2TABLE I. Performance requirements.

Style	RTR12 (Inactive for new design)	RTR22 (Termination "L" is inactive for new design)	RTR24
Minimum resistance (ohms)	2.7	1	
Maximum resistance (ohms)	1 M	10 M	3.01 M
Maximum resistance temperature characteristic in ppm/°C (Ref. to 25°C) (see 3.19)	±50 ppm/°C		
Minimum resistance – ohms	10		
Maximum resistance - ohms	20,000		
Maximum ambient temperature at rated wattage (see figure 2)	85°C		
Maximum ambient temperature at zero wattage (see figure 2)	150°C		
Power rating in watts (see 3.1)	3/4		
Resistance tolerance (in percent)	1, 2		
Maximum percent change in Resistance ±: 1/ Conditioning (3.8)	0.5		
Thermal shock (3.17)	1		
Moisture resistance (3.20)	1		
Shock (specified pulse) (3.21)	1		
Vibration, high frequency (3.22)	1		
Resistance to soldering heat (3.24)	1		
Low temperature operation (3.25)	1		
Low temperature storage (3.26)	1		
High temperature exposure (3.27)	1		
Rotational life (3.29)	1		
Life (3.31)	(see 3.31)		
Resistance tolerance (percent)	5		
Insulation resistance - dry (3.15)	1,000 MΩ Min		
Insulation resistance - wet (3.20)	100 MΩ Min		

1/ Where total resistance change is 1.0 percent or less, it is considered as ±(___ percent +0.05 ohm).

1.2.1.3 Terminals. The terminals are identified by a single letter in accordance with table II.

TABLE II. Terminals.

Symbol	Type of terminal
L	Flexible, insulated-wire leads
P	Printed-circuit pins
W 1/	Printed-circuit pins (edge mounted)
X 2/	Printed-circuit pins (edge mounted, alternate configuration)
Y 3/	Printed-circuit pins (staggered)

1/ Available only in essentially square styles. Pins extend from the edge 180° away from the screw head, and are parallel to the longitudinal axis of the lead screw.

2/ Available only in essentially square styles. Pins extend from the edge 90° away from the screw head, and are perpendicular to the longitudinal axis of the lead screw.

3/ Applicable to style RTR12 (Inactive for new design) only.

1.2.1.4 Product level designator. The product level designation as shown in table III is signified by a single letter (M, P, R, S, or C), which identifies the product level for which the resistor is qualified.

MIL-PRF-39015E
w/ Amendment 2TABLE III. Product level designator.

Product level designator	Product level
C	Non-ER
M	1.0 $\frac{1}{1}$
P	0.1 $\frac{1}{1}$
R	0.01 $\frac{1}{1}$
S	0.001 $\frac{1}{1}$

 $\frac{1}{1}$ FR in percent/1,000 hours

2. APPLICABLE DOCUMENTS

2.1 General. The documents listed in this section are specified in sections 3 and 4 of this specification. This section does not include documents cited in other sections of this specification or recommended for additional information or as examples. While every effort has been made to ensure the completeness of this list, document users are cautioned that they must meet all specified requirements documents cited in sections 3 and 4 of this specification, whether or not they are listed.

2.2 Government documents.

2.2.1 Specifications, standards, and handbooks. The following specifications, standards, and handbooks form a part of this document to the extent specified herein. Unless otherwise specified, the issues of these documents are those cited in the solicitation or contract.

DEPARTMENT OF DEFENSE SPECIFICATIONS

- MIL-PRF-39015/1 - Resistor, Variable, Wire Wound (Lead Screw Actuated), Nonestablished Reliability and Established Reliability, Style RTR12.
(INACTIVE FOR NEW DESIGN.)
- MIL-PRF-39015/2 - Resistor, Variable, Wire Wound (Lead Screw Actuated), Nonestablished Reliability and Established Reliability, Style RTR22.
(TERMINAL "L" IS INACTIVE FOR NEW DESIGN.)
- MIL-PRF-39015/3 - Resistor, Variable, Wire Wound (Lead Screw Actuated), Nonestablished Reliability and Established Reliability, Style RTR24.

*

DEPARTMENT OF DEFENSE STANDARDS

- MIL-STD-202 - Electronic and Electrical Component Parts, Test Methods for.
- MIL-STD-202-101 - Test Method Standard Method 101, Salt Atmosphere (Corrosion).
- MIL-STD-202-106 - Test Method Standard Method 106, Moisture Resistance.
- MIL-STD-202-107 - Test Method Standard Method 107, Thermal Shock.
- MIL-STD-202-108 - Test Method Standard Method 108, Life (At Elevated Ambient Temperature).
- MIL-STD-202-204 - Test Method Standard Method 204, Vibration Frequency.
- MIL-STD-202-208 - Test Method Standard Method 208, Solderability.
- MIL-STD-202-210 - Test Method Standard Method 210, Resistant to Soldering Heat.
- MIL-STD-202-211 - Test Method Standard Method 211, Terminal Strength.
- MIL-STD-202-213 - Test Method Standard Method 213, Shock (Specified Pulse).
- MIL-STD-202-215 - Test Method Standard Method 215, Resistant to Solvents.
- MIL-STD-202-301 - Test Method Standard Method 301, Dielectric Withstanding Voltage.
- MIL-STD-202-303 - Test Method Standard Method 303, DC Resistance.
- MIL-STD-202-304 - Test Method Standard Method 304, Resistance-Temperature Characteristic.
- MIL-STD-690 - Failure Rate Sampling Plans and Procedures.
- MIL-STD-790 - Standard Practice for Established Reliability and High Reliability Qualified Products List (QPL) Systems for Electrical, Electronic, and Fiber Optic Parts Specifications.
- MIL-STD-810 - Environmental Test Methods and Engineering Guidelines.
- MIL-STD-1285 - Marking of Electrical and Electronic Parts.

MIL-PRF-39015E
w/ Amendment 2

* (Copies of these documents are available online at <http://quicksearch.dla.mil>.)

2.3 Non-government publications. The following documents form a part of this document to the extent specified herein. Unless otherwise specified, the issues of the documents which are those listed in the solicitation or contract.

* SAE INTERNATIONAL

[SAE-EIA-554-1](#) - Assessment of Outgoing Nonconforming Levels in Parts Per Million (ppm).
[SAE-EIA-557](#) - Statistical Process Control Systems.

* (Copies of these documents are available online at <http://www.sae.org>.)

* 2.4 Order of precedence. Unless otherwise noted herein or in the contract, in the event of a conflict between the text of this document and the references cited herein (except for associated specifications, specification sheets, or MS sheets), the text of this document takes precedence. Nothing in this document, however, supersedes applicable laws and regulations unless a specific exemption has been obtained.

3. REQUIREMENTS

3.1 Specification sheets. The individual item requirements shall be as specified herein and in accordance with the applicable specification sheet. In the event of any conflict between the requirements of this specification and the specification sheet, the latter shall govern (see 6.2).

3.2 Qualification. Resistors furnished under this specification shall be products that are authorized by the qualifying activity for listing on the applicable Qualified Products List (QPL) before contract award (see 4.4 and 6.3). In addition, the manufacturer shall obtain certification from the qualifying activity that the QPL system requirements of 3.3 and 4.2 have been met and are being maintained. Authorized distributors that are approved to MIL-STD-790 distributor requirements by the QPL manufacturer are listed in the QPL.

3.3 QPL system. The manufacturer shall establish and maintain a QPL system for parts covered by this specification. Requirements for this system are specified in MIL-STD-790 (all product levels) and MIL-STD-690 (ER part only). In addition, the manufacturer shall also establish a Statistical Process Control (SPC) and Part Per Million (PPM) system that meets the requirements as described in 3.3.1 and 3.3.2 respectively.

* 3.3.1 SPC system. As part of the overall MIL-STD-790 QPL system, the manufacturer shall establish a SPC system that meets the requirements of SAE-EIA-557. Typical manufacturing processes for application of SPC include lead attachment, weld strength, and winding or wire. The reliability of resistors furnished under this specification shall be established and maintained in accordance with the requirements and procedures specified in MIL-STD-790 and MIL-STD-690 with details and exceptions specified in 4.2, 4.4.4, and 4.7.

* 3.3.2 PPM system. As part of the overall MIL-STD-790 QPL system, the manufacturer shall establish a PPM system for assessing the average outgoing quality of lots in accordance with SAE-EIA-554-1 and 4.6.4. Data exclusion, in accordance with SAE-EIA-554-1, may be used with approval of the qualifying activity. The PPM system shall identify the PPM rate at the end of each month and shall be based on a six month moving average. PPM and total resistance shall be assessed for each style. Style reporting may include both non-ER and ER style combinations.

3.4 Material. The material shall be as specified herein. However, when a definite material is not specified, a material shall be used which will enable the resistors to meet the performance requirements of this specification. Acceptance or approval of any constituent material shall not be construed as a guarantee of the acceptance of the finished product.

MIL-PRF-39015E
w/ Amendment 2

3.4.1 Plastic. Plastic laminates containing a cotton-fabric base or plastic-molding compounds containing cotton or wood-flour filler shall not be used. Where not machined, plastic material shall have there original, smooth, or polished surfaces. Surfaces that have been sawed, cut, punched, or otherwise machined shall be smooth as practicable in accordance with good manufacturing practice for the intended application.

3.4.2 Ferrous materials. Unless specifically approved by the Government, the use of ferrous material, with the exception of corrosion-resistant steel and resistance-element material is prohibited.

3.5 Interface and physical dimensions requirements. Resistors shall meet the interface, and physical dimensions specified (see 3.1).

3.5.1 Resistance element. The resistance element shall be wound on a form which shall not char or break down as a result of the tests specified herein. The element shall be a continuous unbroken length of conductor without joints, bonds, or welds, except at the junction of the resistor element and the winding terminals. The wire shall possess a uniform cross-sectional area and, unless otherwise specified, in no case shall the nominal diameter be less than .001 inch and absolute diameter is less than .0009 inch (see 3.1).

3.5.2 Protective housing or enclosure. The resistance element of completed resistors shall be protected by a housing, or an enclosure, or both, which shall be free from holes, fissures, chips, or other faults, and shall be such as to minimize the establishment of leakage paths between the terminals resulting from collection of moisture film on the exterior surface of the housing or enclosure. If the housing is made from a metal or metal alloy, it shall be properly protected against corrosion and all fasteners shall be plated. Unplated copper-alloy metals shall not be used in contact with aluminum.

3.5.3 Terminals. Terminals shall be as specified in table II. All terminals shall be fastened securely. Pressure type connections between end terminals and the resistance element shall not be used. Terminals shall be coated to meet the solderability requirements of 3.18 (see 6.12).

3.5.3.1 Terminal identification and circuit diagram.

3.5.3.1.1 Terminal identification.

3.5.3.1.1.1 Terminals P, W, X, and Y type resistors. For terminals P, W, X, and Y type resistors, identification shall be by one of two methods: The numerical designating terminal identification may be marked adjacent to the terminals, or the circuit diagram (see 3.5.3.1.2) may be used, provided that such information clearly indicates the applicable terminals.

3.5.3.1.1.2 Terminal "L" type resistors. For terminal type L resistors, the insulation of the flexible leads shall be color-coded as shown on figure 1.

3.5.3.1.2 Circuit diagram. The circuit diagram shall be marked on any surface of the resistor in a legible manner, as shown on figure 1.

3.5.3.1.3 Legibility. Marking shall remain legible after all tests.

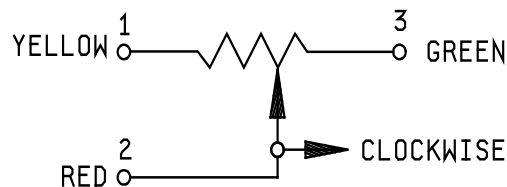

FIGURE 1. Circuit diagram.

MIL-PRF-39015E
w/ Amendment 2

3.5.4 Securing of screw-thread assemblies. Screw-thread assemblies shall not loosen as a result of the tests specified herein.

3.5.5 Lead screw actuator. The lead screw actuator shall be of corrosion resistant material with the head insulated from all electrical parts of the resistor.

3.5.6 Contact-arm assembly. Contact pressure on the resistance element shall be maintained by positive pressure and shall permit smooth electrical and mechanical control of the resistor over the entire range. The moving contact shall have continuous electrical contact with its terminal throughout the entire mechanical travel and shall be insulated from the lead screw actuator head and case.

3.5.7 Clutches. Resistors shall contain clutches which permit the contact arm to idle at either end of the resistance element without electrical or mechanical malfunction (see 3.16.2).

3.5.8 Solder dip (retinning) leads. The manufacturer (or his authorized category B or category C distributor) may solder dip/retin the leads of product supplied to this specification provided the solder dip process (see appendix A) has been approved by the qualifying activity.

3.5.9 Pure tin. The use of pure tin, as an underplate or final finish is prohibited both internally and externally. Tin content of resistor components and solder shall not exceed 97 percent, by mass. Tin shall be alloyed with a minimum of 3 percent lead, by mass (see 6.13).

3.6 Power rating. The resistors shall have a power rating based on continuous full-load operation at the ambient temperature specified (see 3.1 and figure 2). For temperatures in excess of those specified value, the load shall be derated as shown on figure 2. Power ratings as specified (see 3.1) are applicable only when the maximum resistance is engaged in the circuit.

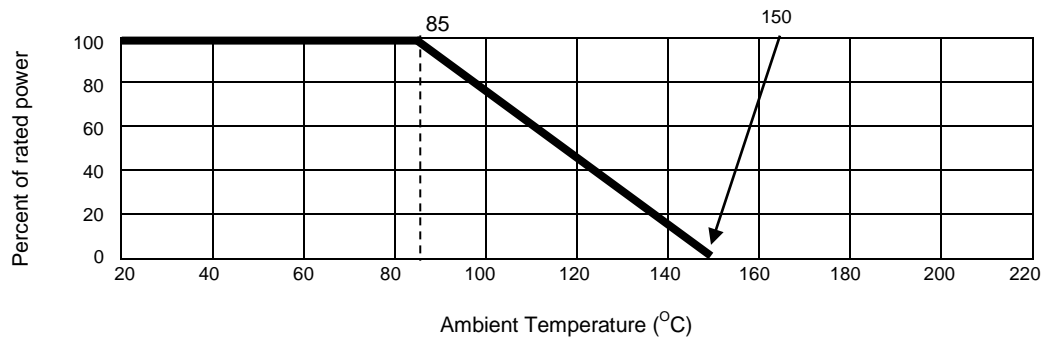

FIGURE 2. Derating curve for high ambient temperatures.

MIL-PRF-39015E
w/ Amendment 2

3.7 Voltage rating. Each resistor element shall have a rated direct current (dc) continuous working voltage or an approximate sine-wave root-mean-square (rms) continuous working voltage corresponding to the wattage (power) rating, as determined from the following formula:

$$E = \sqrt{PR}$$

Where:

- E = Rated dc or rms ac continuous working voltage at commercial-line frequency and waveform.
- P = Power rating (see 3.1).
- R = Nominal resistance (see 3.1).

In no case shall the rated dc or rms ac continuous working voltage be greater than the applicable maximum value (see 3.1).

3.8 Conditioning. When resistors are tested as specified in 4.8.2, there shall be no evidence of mechanical damage and the change in resistance shall not exceed ± 0.5 percent for resistance values of 100 ohms or greater, and $\pm(0.5$ percent +0.05 ohm) for values below 100 ohms.

3.9 Peak noise. When resistors are tested as specified in 4.8.3, the peak noise resistance shall not exceed 500 ohms, with the following exceptions:

- In group I of table V: Shall not exceed 100 ohms.
- In group IV of table V: Shall not exceed 200 ohms.
- In table VI Shall not exceed 100 ohms.

3.10 DC resistance.

3.10.1 Total resistance. When measured as specified in 4.8.4.1, the total direct current (dc) resistance shall not deviate from the specified nominal (see 3.1) by more than ± 5 percent.

3.10.2 Absolute minimum resistance. When measured as specified in 4.8.4.2, the absolute minimum resistance shall not exceed 0.25 percent of the nominal total resistance value, or 1 ohm, whichever is greater.

3.10.3 End resistance. When measured as specified in 4.8.4.3, the end resistance shall not exceed 2 percent of the nominal total resistance value, or 1 ohm, whichever is greater.

3.10.4 Resistance value deviations. All maximum deviations as specified in this section are to be considered absolute limits with the exception of the contact resistance adjustments.

3.11 Immersion (not applicable to L terminals). When resistors are tested as specified in 4.8.5, no continuous stream of bubbles shall emanate from any concentrated point of the resistor. When resistors are subjected to the dye penetrate test, there shall be no evidence of dye in the internal cavities.

3.12 Continuity. When resistors are tested as specified in 4.8.6, the change in voltage or resistance shall be smooth and unidirectional throughout the effective electrical travel.

3.13 Actual effective electrical travel. When resistors are tested as specified in 4.8.7, the number of turns of the operating shaft necessary for the contact arm to traverse the resistance element shall be as specified (see 3.1).

3.14 Dielectric withstanding voltage. When resistors are tested as specified in 4.8.8, there shall be no evidence of damage, arcing, or breakdown. The leakage current shall not exceed 1 milliamperere.

3.15 Insulation resistance. When resistors are tested as specified in 4.8.9, the dry insulation resistance shall not be less than 1,000 megohms.

MIL-PRF-39015E
w/ Amendment 23.16 Torque.

3.16.1 Operating. When resistors are tested as specified 4.8.10.1, the torque required to move the contact arm shall be as specified (see 3.1).

3.16.2 Clutch. When resistors are tested as specified in 4.8.10.2, the contact arm shall idle against the stop without electrical ohmmeter discontinuity or evidence of mechanical damage. The travel of the contact arm shall also be capable of reversing direction.

3.17 Thermal shock. When resistors are tested as specified in 4.8.11, the change in total resistance shall not exceed ± 1 percent for resistance values of 100 ohms or greater $\pm(1.0$ percent $+0.05$ ohm) for values below 100 ohms. The change in setting stability shall not exceed ± 0.5 percent plus the specified maximum resolution (see 3.1). Resistors shall meet the requirements of 3.10.1 and there shall be no evidence of mechanical damage.

3.18 Solderability (applicable to terminals P, W, X, and Y only). When resistors are tested as specified in 4.8.12, they shall meet the criteria for wire lead terminal evaluation in the test method.

3.19 Resistance temperature characteristic. When resistors are tested as specified in 4.8.13, the, resistance temperature characteristic, referred to an ambient temperature of 25°C, shall not exceed ± 0.005 percent per degree Celsius (50 PPM/°C) (see table X and table XI). This measurement is made with the contact arm against the stop.

3.20 Moisture resistance. When resistors are tested as specified in 4.8.14, resistors shall meet the following requirements:

Total resistance:	Change shall not exceed ± 1 percent for resistance values of 100 ohms or greater, and $\pm(1.0$ percent $+0.05$ ohm) for values below 100 ohms.
Insulation resistance:	Shall not be less than 100 megohms.
Visual examination:	There shall be no evidence of mechanical damage.

3.21 Shock (specified pulse). When resistors are tested as specified in 4.8.15, the change in total resistance shall not exceed ± 1 percent for resistance values of 100 ohms and greater and $\pm(1.0$ percent $+0.05$ ohm) for values below 100 ohms. The change in setting stability shall not exceed ± 0.5 percent plus the specified maximum resolution (see 3.1) and there shall be no electrical discontinuity or evidence of mechanical damage.

3.22 Vibration, high frequency. When resistors are tested as specified in 4.8.16, there shall be no electrical discontinuity and resistors shall meet the following requirements:

Setting stability:	Change shall not exceed 0.5 percent plus the specified maximum resolution (see 3.1).
Total resistance:	Change shall not exceed ± 1 percent for resistance values of 100 ohms or greater, and $\pm(1.0$ percent $+0.05$ ohm) for values below 100 ohms.
Visual examination:	There shall be no evidence of mechanical damage.

3.23 Salt spray (corrosion). When resistors are tested as specified in 4.8.17, there shall be no evidence of mechanical damage.

3.24 Resistance to soldering heat (applicable to terminals P, W, X, and Y). When resistors are tested as specified in 4.8.18, the change in total resistance shall not exceed ± 1 percent for resistance values of 100 ohms or greater, and $\pm(1.0$ percent $+0.05$ ohm) for values below 100 ohms. There shall be no evidence of mechanical damage.

MIL-PRF-39015E
w/ Amendment 2

3.25 Low temperature operation. When resistors are tested as specified 4.8.19, they shall meet the following requirements:

Setting stability:	Change shall not exceed 0.5 percent plus the specified maximum resolution (see 3.1).
Total resistance:	Change shall not exceed ± 1 percent for resistance values of 100 ohms or greater, and $\pm(1.0$ percent +0.05 ohm) for values below 100 ohms.
Visual examination:	There shall be no evidence of mechanical damage.

3.26 Low temperature storage (for qualification only). When resistors are tested as specified in 4.8.20, the change in total resistance shall not exceed ± 1 percent for resistance values of 100 ohms or greater, and $\pm(1.0$ percent +0.05 ohm) for values below 100 ohms. There shall be no evidence of mechanical damage.

3.27 High temperature exposure. When resistors are tested as specified 4.8.21, they shall meet the following requirements:

Setting stability:	Change shall not exceed 0.5 percent plus the specified maximum resolution (see 3.1).
Total resistance:	Change shall not exceed ± 1 percent for resistance values of 100 ohms or greater, and $\pm(1.0$ percent +0.05 ohm) for values below 100 ohms.
Dielectric withstanding voltage (atmospheric pressure):	As specified in 3.14.
Insulation resistance:	Shall not be less than 1,000 megohms.
Visual examination:	There shall be no evidence of mechanical damage.

3.28 Integrity of shaft. When resistors are tested as specified 4.8.22, the shaft shall remain in one piece.

3.29 Rotational life. When resistors are tested as specified in 4.8.23, the change in total resistance shall not exceed ± 2 percent, and there shall be no evidence of mechanical damage. The failure of one pair of units being tested shall not count as a failure for the companion unit.

3.30 Terminal strength. When resistors are tested as specified in 4.8.24, there shall be no evidence of mechanical damage and resistors shall be electrically continuous.

3.31 Life.

3.31.1 Qualification. When resistors are tested as specified in 4.8.25, there shall be no evidence of mechanical damage. The change in resistance between the initial measurement and any of the succeeding measurements up to and including 2,000 hours shall not exceed ± 2 percent plus specified maximum resolution (see 3.1).

3.31.2 FR level determination. When resistors are tested as specified in 4.8.25, there shall be no evidence of mechanical damage to the resistance element or enclosure. The change in resistance between the initial measurement and any of the succeeding measurements shall not exceed ± 3 percent plus the specified resolution. This single failure criterion shall be applicable to all measurements during the life test for purposes of determining FR level qualification and is applicable as a parallel requirement with 3.31.1 to the measurements made during the life test specified for the qualification test.

3.32 Resistance to solvents. When resistors are tested as specified in 4.8.26, there shall be no evidence of mechanical damage and the markings shall remain legible.

3.33 Fungus. All external materials shall be nonnutrient to fungus growth or shall be treated to retard fungus growth. The manufacturer shall verify by certification that all external materials are fungus resistant or shall test the resistors as specified in 4.8.27. There shall be no evidence of fungus growth on the external surfaces.

MIL-PRF-39015E
w/ Amendment 2

3.34 Marking. Resistors shall be marked with the PIN (see 1.2.1 and 3.1) and "JAN" brand. In addition, the resistor shall be date and source coded in accordance with MIL-STD-1285. Where the date coding does not provide specific lot identification, the manufacturer shall mark the resistor with a lot code symbol. Where required, the PIN may appear on two lines as shown in the following example:

M39015/2 - Document number and slash sheet.
-001PM - Resistance dash number, pin style, product level.

Marking shall remain legible at the end of all tests. The date lot code and lot symbol shall provide traceability through all production operation and shall represent a specific critical point consistently provide by the manufacturer.

* 3.34.1 JAN and J marking. The United States Government has adopted, and is exercising legitimate control over the certification marks "JAN" and "J", respectively, to indicate so marked or identified are manufactured to, and meet all the requirements of specifications. Accordingly, items acquired to, and meeting all of the criteria specified herein and in applicable specifications shall bear the certification mark "JAN" except that items too small to bear the certification mark "JAN" shall bear the letter "J". The "JAN" or "J" shall be placed immediately before the part number except that if such location would place a hardship on the manufacturer in connection with such marking, the "JAN" or "J" may be located on the first line above or below the part number. Items furnished under contracts or orders which either permit or require deviation from the conditions or requirements specified herein or in applicable specifications shall not bear "JAN" or "J". In the event item fails to meet the requirements of this specification and the applicable specification sheets or associated specifications, the manufacturer shall remove completely the military part number and the "JAN" or the "J" from the sample tested and also from all items represented by the sample. The "JAN" or "J" certification mark shall not be used on products acquired to contractor drawings or specifications. The United States Government has obtained Certificate of Registration Number 504,860 for the certification mark "JAN", and Registration Number 2,577,735 for the certification mark "J".

3.34.2 Supplying to higher product levels. A manufacturer may supply to all higher FR levels than that to which they are qualified. Parts qualified and marked to lower FR levels, with procuring agency approval, are substitutable for higher rate level parts, and shall not be remarked unless specified in the contract or purchase order (see 6.2 and table IV).

TABLE IV. Product level substitution.

Product level	Acceptable product level substitution
S (.001)	
R (.01)	S
P (0.1)	S, R
M (1.0)	S, R, P
C (non-ER)	S, R, P, M

* 3.35 Recycled, recovered, environmentally preferable, or biobased materials. Recycled, recovered, environmentally preferable or biobased materials should be used to the maximum extent possible, provided that the material meets or exceeds the operational and maintenance requirements, and promotes economically advantageous life cycle costs.

3.36 Workmanship. Resistors shall be processed in such a manner as to be uniform in quality and shall be free any defects that will affect life, serviceability or appearance.

MIL-PRF-39015E
w/ Amendment 2

4. VERIFICATION

4.1 Classification of inspections. The inspection requirements specified herein are classified as follows:

- a. Qualification inspection (see 4.4).
- b. Verification of qualification (see 4.5).
- c. Conformance inspection (see 4.6).
- d. Periodic group C inspection (see 4.7).

4.2 Reliability and quality.

4.2.1 QPL system. The manufacturer shall establish and maintain a QPL system in accordance with 3.3. Evidence of such compliance is a prerequisite for qualification and retention of qualification.

* 4.2.2 SPC. A SPC program shall be establish and maintained in accordance with [SAE-EIA-557](#). Evidence of such compliance shall be a prerequisite for qualification and verification of qualification.

4.3 Inspection conditions and precautions.

4.3.1 Inspection conditions. Unless otherwise specified herein, all inspections shall be performed in accordance with the test conditions specified in the "GENERAL REQUIREMENTS" OF [MIL-STD-202](#).

4.3.2 Precautions. Adequate precautions shall be taken during inspection to prevent condensation of moisture on resistors, except during moisture resistance test. Precautions shall be taken to prevent damage by heat when soldering resistor leads to terminals.

4.4 Qualification inspection. Qualification inspection shall be performed at a laboratory acceptable to the Government (see 6.3), on sample units produced with equipment and procedures normally used in production.

4.4.1 Sample. The number of sample units comprising a sample of resistors to be submitted for qualification inspection shall be as specified in the [appendix A](#) to this specification. The sample shall be taken at random from a production run and shall be produced with equipment and procedures normally used in production.

4.4.2 Test routine. Sample units shall be subjected to the qualification inspection specified in [table V](#), in the order shown. Sample test routine shall be as indicated in the appendix A. The qualification of other than "P" type terminals shall be only applicable at the time of the original submission (see [table A-I](#)). The manufacturer shall not submit all of one terminal type at original submission and request qualification extension to a different terminal by partial submission at a later date. The qualification life sample shall be continued on test for 10,000 hours. The requirement of [3.31.2](#) shall apply for FR data accumulation.

4.4.3 Defectives. Defectives in excess of those allowed in [table V](#) shall be cause for refusal to grant qualification approval.

MIL-PRF-39015E
w/ Amendment 2

4.4.4 FR qualification. FR qualification shall be in accordance with the general and detail requirements of [MIL-STD-690](#) and the following details:

- a. Procedure I: Qualification at the initial FR level. Level M (1.0 percent of FRSP-60) shall apply. Sample units shall be subjected to the qualification inspection specified in group VII, [table V](#) (see [4.4.2](#)). Entire life test sample shall continue on test to 10,000 hours as specified in [4.8.25](#), upon completion of the 2,000 hour qualification.
- b. Procedure II: Extension of qualification to lower FR levels. To extend qualification to the "R" level (0.01 percent) and "S" (0.001 percent) FR level unit hours, two or more styles of similar construction may be combined. Style combination shall be as described for lot formation ([4.6.2](#)).
- c. Procedure III: Maintenance of FR level qualification. Maintenance period "B" of FRSP-10 shall apply. Regardless of the number of production lots produced during this period, the specified number of unit hours shall be accumulated to maintain qualification (see [4.7](#)).

4.4.5 PPM level verification. The contractor is responsible for establishing a quality system to assess the PPM level of lots that are subjected to group A inspections. The PPM defect level shall be based on a 6 month moving average.

4.5 Verification of qualification. Every 6 months, the manufacturer shall provide verification of qualification to the qualifying activity. Continued qualification is based on meeting the following requirements.

- a. [MIL-STD-790](#) program.
- b. Design of resistor has not been modified.
- c. Lot rejection for group A (subgroup 1 and subgroup 3) does not exceed 10 percent or one lot, whichever is greater.
- d. Periodic group B inspection.
- e. FR levels.
- f. PPM assessment (NOTE: Grouping of style is permitted).
- g. Continued qualification to non-ER ("C") shall be based on continued maintenance of qualification for the ER part (minimum "M" FR level maintained).

4.6 Conformance inspection.

4.6.1 Inspection of product for delivery.

4.6.1.1 Non-ER resistors. Inspection of product for delivery shall consist of the requirements in [4.6.3.1](#).

4.6.1.2 ER resistors. Inspection of product for delivery shall consist of group A inspection (see [4.6.3.2](#)).

MIL-PRF-39015E
w/ Amendment 2TABLE V. Qualification inspection.

Inspection	Requirement paragraph	Method paragraph	Number of sample units <u>1/</u>	Number of defectives allowed <u>2/</u>
<u>Group I</u> <u>3/</u> <u>4/</u> Conditioning Peak noise Total resistance Immersion (not applicable to L terminals)	3.8 3.9 3.10.1 3.11	4.8.2 4.8.3 4.8.4.1 4.8.5	All sample Units	Not applicable
<u>Group IA</u> <u>4/</u> Visual and mechanical inspection <u>5/</u> Continuity Actual effective electrical travel Absolute minimum resistance End resistance Dielectric withstanding voltage Insulation resistance Torque Thermal shock	3.1, 3.3 to 3.3.2, incl., 3.4, to 3.5.9 incl., and 3.33 and 3.34 incl. 3.12 3.13 3.10.2 3.10.3 3.14 3.15 3.16 3.17	4.8.1 4.8.6 4.8.7 4.8.4.2 4.8.4.3 4.8.8 4.8.9 4.8.10 4.8.11	All sample unit except those for group II	(Visual and mechanical inspection not applicable) 0
<u>Group II</u> Solderability (applicable to terminals P, W, X, and Y)	3.18	4.8.12	6 any value	0
<u>Group III</u> Resistance temperature characteristic Moisture resistance Peak noise	3.19 3.20 3.9	4.8.13 4.8.14 4.8.3	12 6 high 6 low	1
<u>Group IV</u> Shock (specified pulse) Vibration, high frequency Peak noise Salt spray (corrosion)	3.21 3.22 3.9 3.23	4.8.15 4.8.16 4.8.3 4.8.17	12 6 high 6 low	
<u>Group V</u> Resistance to soldering heat (applicable to terminals P, W, X, and Y) Low temperature operation Low temperature storage High temperature exposure Peak noise Integrity of shaft	3.24 3.25 3.26 3.27 3.9 3.28	4.8.18 4.8.19 4.8.20 4.8.21 4.8.3 4.8.22	12 6 high 6 low	
<u>Group VI</u> Rotational life Peak noise Terminal strength	3.29 3.9 3.30	4.8.23 4.8.3 4.8.24	12 6 high 6 low	1
<u>Group VII</u> Life	3.31	4.8.25	102 51 high 51 low	1
<u>Group VIII</u> Resistance to solvents	3.32	4.8.26	3 any value	0
<u>Group IX</u> Fungus <u>6/</u>	3.33	4.8.27	10	0

1/ See [appendix A](#) for details.

2/ Failure of a single resistor in one or more tests of a group shall be charged as a single defective.

3/ Group I tests need not be performed if manufacturer presents certified data proving tests have been previously performed on the qualification sample units.

4/ Nondestructive tests.

5/ Marking shall be considered defective only if illegible or missing. Marking shall remain legible at the end of all tests.

6/ Test shall not be performed if manufacturer certifies that all external materials are fungus resistant.

MIL-PRF-39015E
w/ Amendment 24.6.2 Inspection and production lot.

4.6.2.1 Inspection lot. An inspection lot, as far as practicable, shall consist of all resistors of the same style, characteristic, and protective enclosure or coating and manufactured under essentially the same process and conditions during a manufacturing period of 1 month maximum. For purposes of lot formation all terminal types may be included in the same lot; however, all lead types which are combined shall have the same method of terminal attachment. All leads in the lot shall be represented in a similar proportion by samples selected for inspection. Non-ER and ER lots shall be kept separate.

4.6.2.2 Production lot. A production lot shall consist of all resistors of the same characteristic, style, nominal resistance value, and resistance tolerance. Manufacture of all parts in the lot shall have been started, processed, assembled, and tested as a group. Lot identity shall be maintained throughout the manufacturing cycle. Non-ER and ER lots shall be kept separate.

4.6.3 Group A inspection.

4.6.3.1 Non-ER resistors. The manufacturer shall establish and maintain an inspection system to verify resistors meet visual/mechanical, peak noise, total resistance, immersion, and solderability requirements. In-line or process control may be part of such a system. The inspection system shall also include criteria for lot rejection and corrective actions. The inspection system shall be verified under the overall MIL-STD-790 QPL system. NOTE: Since the non-ER (C level) is the ER design without the mandatory conformance inspection and FR level assessment, this product is still expected to meet the environmental qualification type requirements (e.g., moisture resistance, shock, vibration, etc.).

4.6.3.2 ER resistors. Group A inspection shall consist of the inspections specified in [table VI](#), in the order shown.

4.6.3.2.1 Subgroup 1 tests. Subgroup 1 tests shall be performed on a production lot basis on 100 percent of the product supplied under this specification. Resistors that are out of resistance tolerance, or which experience a change in resistance greater than that permitted for the tests of this subgroup, shall be removed from the lot. Only lots having not more than 10 percent rejects, or one resistor, whichever is greater, due to exceeding the specified resistance change limit, as a result of subgroup 1 tests, shall be furnished on orders. Corrective action shall be taken on such values and new pieces furnished.

4.6.3.2.2 Manufacturer's production inspection. If the manufacturer performs tests equal to or more stringent than those specified in group A, subgroup 1, as the final step of this production process, group A, subgroup 1 inspection may be waived and the data resulting from the manufacturer's production tests may be used instead. Authority to waive the subgroup 1 inspection shall be granted by the qualifying activity only. The following criteria must be complied with:

- a. Production tests are identical to or more stringent than those specified for subgroup 1 tests.
- b. One hundred percent of the product supplied to these tests.
- c. Failure criteria are identical to, or more stringent than, those specified for subgroup 1 tests.
- d. Lot rejection criteria are identical to, or more stringent than, those specified for subgroup 1 tests.
- e. Once approved, future changes require approval from the qualifying activity.

4.6.3.2.3 Subgroup 2 tests. The subgroup 2 tests shall be performed on an inspection lot basis for ER parts. A random sample of resistors shall be selected in accordance with [table VII](#). In the event of one or more failures, the lot is rejected. The rejected lot may be rescreened and the defects removed and resubmitted to the table VII sample plan. If one or more defects are found in this second sample, the lot is rejected and shall not be supplied to this specification. (NOTE: This corrective action applies to the original quality defect found. If another defect type is found in the second sample, a rescreen for that defect is also permitted).

MIL-PRF-39015E
w/ Amendment 2TABLE VI. Group A inspection.

Inspection	Requirement paragraph	Method paragraph	Sampling procedure
<u>Subgroup 1</u> <u>1/</u> <u>2/</u> Conditioning Peak noise Total resistance <u>3/</u> Immersion (not applicable to L terminals)	3.8 3.9 3.10.1 3.11	4.8.2 4.8.3 4.8.4.1 4.8.5	100 percent inspection
<u>Subgroup 2</u> Visual inspection <u>4/</u>	3.1, 3.3, to 3.3.2 incl., 3.4 to 3.5.9 incl., 3.33 and 3.34 incl.	4.8.1	See 4.6.3.2.3
<u>Subgroup 3</u> <u>5/</u> <u>6/</u> Continuity Absolute minimum resistance End resistance Actual effective electrical travel Dielectric withstanding voltage Insulation resistance Torque Thermal shock	3.12 3.10.2 3.10.3 3.13 3.14 3.15 3.16 3.17	4.8.6 4.8.4.2 4.8.4.3 4.8.7 4.8.8 4.8.9 4.8.10 4.8.11	See 4.6.3.2.4
<u>Subgroup 4</u> Solderability <u>5/</u> <u>7/</u> (applicable to terminals P, W, X, and Y)	3.18	4.8.12	See 4.6.3.2.5

1/ 100 percent solder dip may be performed prior to immersion (see [A.5.3](#))

2/ At the manufacturer's option, the determination of resistance change may be by any method which is within the accuracy requirements of this specification.

3/ Resistors shall meet this specified initial resistance tolerance. The resistance measurement made upon completion of the conditioning test may be used if a measurement was made which can, without conversion, be directly related to nominal resistance value and tolerance.

4/ The manufacturer may request the deletion of the subgroup 2 visual examination test, provided an in-line or process control system for assessing and assuring the applicable requirements of the visual examination test can be validated and approved by the qualifying activity. Deletion of the test does not relieve the manufacturer from meeting this test requirement in case of dispute. If the design, material, construction, or processing of the part is changed or if there are any quality problems, the qualifying activity may require resumption of the test.

5/ At the option of the manufacturer, subgroup 2, subgroup 3, and subgroup 4 may be performed concurrently with a separate set of samples.

6/ If the manufacturer can demonstrate that this test has been performed for 6 month with zero failures, the frequency of this test, with the approval of the qualifying activity, can be performed on an annual basis. If the design, material, construction, or processing of the part is changed, or if there are any quality problems or failures, the qualifying activity may require resumption of the original test frequency.

7/ The manufacturer may request the deletion of the subgroup 4 solderability test, provided an in-line or process control system for assessing and assuring the solderability of leads can be validated and approved by the qualifying activity. Deletion of the test does not relieve the manufacturer from meeting this test requirement in case of dispute. If the design, material, construction, or processing of the part is changed or if there are any quality problems, the qualifying activity may require resumption of the test.

4.6.3.2.4 Subgroup 3 tests. Subgroup 3 shall be performed on an inspection lot basis. A sample of 13 parts shall be randomly selected. If one or more defects are found, the lot shall be rescreened and defects removed. A new sample of 13 parts shall be randomly selected. Of one or more defects are found in this second sample, the lot shall be rejected and shall not be supplied to this specification.

MIL-PRF-39015E
w/ Amendment 2TABLE VII. Sampling plans for PPM categories.

Lot size	Sample size PPM	Sample size subgroup 2
1 - 13	100 percent	100 percent
14 - 125	100 percent	13
126 - 150	125	13
151 - 280	125	20
281 - 500	125	29
501 - 1,200	125	34
1,201 - 3,200	125	42
3,201 - 10,000	125	50
10,001 - 35,000	294	60
35,001 - 150,000	294	74
150,001 - 500,000	345	90
500,001 and over	435	102

4.6.3.2.5 Subgroup 4 (solderability). The subgroup 4 test shall be performed on an inspection lot basis for ER parts. A sample shall be selected from each lot in accordance with table VIII. As an option, the manufacturer may use electrical rejects from the subgroup 1 test for all or part of the sample. If there are one or more defects, the lot is rejected. The manufacturer may use one of the following options for corrective action:

- a. Each production lot that was used to form the failed inspection lot shall be individually submitted to the solderability test. Production lots that pass the solderability test are available for shipment. Production lots that fail can be submitted to the solder dip procedure in 4.6.3.2.5.b.
- b. The failed lot is submitted to a 100 percent hot solder dip using an approved solder dip process in accordance with the 3.5.8. A subsequent solderability test shall then be performed. If the lot passes, it is available for shipment; if the lot fails, the manufacturer may perform the hot solder dip one additional time. If the lot fails to pass, the lot is considered rejected and shall not be supplied to this specification.

TABLE VIII. Solderability sampling plan.

Lot size	Sample size
1 to 3,200	5
3,201 to 10,000	8
10,001 to 35,000	13
35,001 and over	20

4.6.3.2.5.1 Disposition of samples. The solderability test is considered a destructive test and samples submitted to the solderability test shall not be supplied on the contract.

4.6.4 PPM assessment (non-ER and ER). The manufacturer shall establish and maintain a system for assessing the average outgoing quality in PPM of lots supplied to this specification. This PPM assessment should be based on inspections performed on each inspection lot, verifying that resistors meet total resistance, and tolerance requirements (i.e., PPM). For ER resistors, this inspection shall occur after the group A, subgroup 1, 100 percent screens have been completed. In the event of one or more failures, the lot is rejected.

4.6.4.1 Sampling plan. Minimum sample sizes for inspection lots shall be selected in accordance with table VII. For non-ER resistors, the sampling system and plan used for the group A inspection (see 4.6.3.1) may be the basis for assessing PPM.

MIL-PRF-39015E
w/ Amendment 2

4.6.4.2 Rejected lots. Any rejected lot shall be segregated from new lots and those lots that have passed PPM assessment. A rejected lot may be rescreened for the quality characteristics found defective in the sample and any defects removed. A new second sample shall be randomly selected. If one or more defects are found, this lot is rejected and shall not be supplied to this specification.

- * 4.6.4.3 PPM calculations. PPM calculations shall be based on the accumulated results of the initial sample. Calculations and exclusion shall be in accordance with [SAE-EIA-554-1](#) and qualifying activity approval. (NOTE: PPM calculations shall not be based on the second sample submission for a rejected lot as described [4.6.4.2](#)).

4.7 Periodic group B inspection (ER only). Periodic inspection shall consist of group B inspection tests specified in table IX, in the order shown. They shall be performed on sample units selected from lots that have passed the group A inspections. Except where the results of these inspections show noncompliance with the applicable requirements (see [4.7.5](#)), delivery of products which have passed group A inspections shall not be delayed pending the results of these periodic inspections.

TABLE IX. Group B inspection.

Inspection	Requirement paragraph	Method paragraph	Number of samples	Number of defectives
<u>Quarterly</u> <u>Subgroup 1</u> Life	3.31	4.8.25	See 4.7.2.1	See 4.7.2.1
<u>Quarterly</u> <u>Subgroup 2</u> 1/ Resistance temperature characteristic Moisture resistance Peak noise	3.19 3.20 3.9	4.8.13 4.8.14 4.8.3	12 6 highest 6 lowest	1
<u>Quarterly</u> <u>Subgroup 3</u> 2/ Rotational life Peak noise Terminal strength	3.29 3.9 3.30	4.8.23 4.8.3 4.8.24	12 6 highest 6 lowest	
<u>Semiannually</u> <u>Subgroup 1</u> Resistance to soldering heat 1/ High temperature exposure 2/ Peak noise 2/ Integrity of shaft 1/	3.24 3.27 3.9 3.28	4.8.18 4.8.21 4.8.3 4.8.22	12 6 highest 6 lowest	1
<u>Semiannually</u> <u>Subgroup 2</u> 2/ Low temperature operation Shock (specified pulse) Vibration, high frequency	3.25 3.21 3.22	4.8.19 4.8.15 4.8.16	12 6 highest 6 lowest	
<u>Semiannually</u> <u>Subgroup 3</u> 1/ Resistance to solvents	3.32	4.8.26	3 any value	0

1/ If the manufacturer can demonstrate that this test has been performed for five consecutive times with zero failures, the frequency of this test, with the approval of the qualifying activity, can be performed on an annual basis. If the design, material, construction, or processing of the part is changed, or if there are any quality problems or failures, the qualifying activity may require resumption of the original test frequency.

2/ If the manufacturer can demonstrate that these tests has been performed for five consecutive times with zero failures, these tests, with the approval of the qualifying activity, can be deleted. The manufacturer however, shall perform these tests every three years after the deletion as part of long term design verification. If the design, material, construction, or processing of the part is changed, or if there are any problems, the qualifying activity may require resumption of the specified testing. Deletion of testing does not relieve the manufacturer from meeting the test requirement in case of dispute.

MIL-PRF-39015E
w/ Amendment 2

4.7.1 Sampling plan. If more than 1,000 resistors of any style or style grouping are produced over the maintenance period, the group B tests shall be performed as specified. If the production rate is less than 1,000 resistors for any style or style grouping over the maintenance period then the monthly, quarterly, or semi-annual group B inspection may be postponed until at least 1,000 resistors of that style or style grouping are produced (except for the monthly life test). In any case, the monthly tests shall be performed at least once every 3 months. The quarterly tests shall be performed at least every 6 months and the semi-annual tests shall be performed at least once every year. This requirement is waived if the manufacturer has obtained a reduced inspection status through the qualifying activity.

All qualified styles may be grouped together in a single sample. This can be accomplished by proportion based on manufacturing percentages by style, equally divided by style, or by establishing an alternating style sequence. In order to incorporate a style sampling grouping, a written description must be presented and approved by the qualifying activity. This plan must assure that the grouping only combines styles of the same basic design, encapsulation material, and the same element type.

4.7.2 Quarterly.

4.7.2.1 Subgroup 1. Samples shall be accumulated from each inspection lot and placed on extended life (see 4.8.25) for the full 10,000 hour life test. A sufficient number of samples shall be selected from each lot by the manufacturer so that the maintenance of FR requirements are complied with, within the specified maintenance period. In any event, a minimum of 5 samples shall be selected from each lot. As far as practicable, the manufacturer shall select the resistance values so that all resistance decades produced during the maintenance period are represented.

4.7.2.2 Subgroup 2 and subgroup 3. Quarterly, the specified number of sample units shall be subjected to the tests specified in table IX.

4.7.3 Semiannual. Sample units and tests shall be as specified in table IX.

4.7.4 Disposition of sample units. Sample units which have been subjected to group B inspection shall not be delivered on the contract or purchase order.

4.7.5 Noncompliance. If a sample fails to pass group B inspection, the manufacturer shall immediately notify the qualifying activity and the cognizant inspection activity of such failure and take corrective action on the materials or processes, or both, as warranted, and on all units of product which can be corrected and which were manufactured under essentially the same materials and processes and which are considered subject to the same failure. For ER level, acceptance and shipment of the product shall be discontinued until corrective action; acceptable to the qualifying activity has been taken. For C level, stop shipment may not be necessary depending on the nature of the failure. After the corrective action has been taken, group B inspection shall be repeated on additional sample units (all inspections, or the inspection which the original sample failed, at the option of the qualifying activity). Group A inspection may be reinstated; however, final acceptance and shipment shall be withheld until the group B inspection has shown that the corrective action was successful.

4.8 Methods of inspection.

4.8.1 Visual and mechanical inspection. Resistors shall be examined to verify that the materials, design, construction, physical dimensions, marking, and workmanship are in accordance with the applicable requirements (see 3.1, 3.4 to 3.4.2 inclusive, and 3.5 to 3.5.9 inclusive, and 3.32 to 3.33 inclusive).

MIL-PRF-39015E
w/ Amendment 2

- * 4.8.2 Conditioning (see 3.8). Resistors shall be conditioned in accordance with [MIL-STD-202-108](#). The following details and exceptions shall apply:
- a. Method of mounting: Supported by their terminals (resistor not mounted on life test chassis). Resistors shall be so arranged that the temperature of any one resistor shall not appreciably influence the temperature of the other resistor. There shall be no circulation of air over the resistors other than that caused by heat of the resistors.
 - b. Temperature and tolerance: 25°C +10°C, -5°C.
 - c. Initial measurements: Initial total resistance shall be measured after mounting at 25°C +10°C, -5°C as specified in [4.8.4.1](#). This initial measurement shall be used as the reference temperature for all subsequent measurements.
 - d. Operating condition: DC continuous working voltage or a continuous working voltage from an ac supply at commercial line frequency and waveform equivalent to 1 watt power dissipation shall be applied between the end terminals intermittently one and one-half hours "on" and one-half hour "off" for a minimum of 50 hours +8 hours, -0 hour at a temperature of 25°C +10°C, -5°C. Each resistor shall dissipate 1 watt (see [3.1](#)).
 - e. Measurement after conditioning: Total resistance shall be measured at the end of the 50 hours +8 hours, -0 hour as specified in [4.8.4.1](#) after load has been removed and the resistors stabilized.
 - f. Examination after conditioning: Resistors shall be examined for evidence of mechanical damage.
 - g. Test duration: 50 hours +8 hours, -0 hours minimum.

4.8.3 Peak noise (3.9). Peak noise resistance shall be measured with the measuring circuit shown on [figure 3](#), or its equivalent. The lead screw shall be rotated in both directions through 90 percent of the actual effective electrical travel for a maximum of 6 cycles. If the product passes on any one of the first three cycles, then the product is acceptable. Only the last three cycles shall count in determining whether or not a noise is observed at least twice in the same location. Group A, subgroup 1, product acceptance may be determined based on one cycle minimum where compliance to the specification is demonstrated. The rate of rotation of the lead screw shall be such that the wiper completes one cycle in 5 seconds minimum to 2 minutes maximum. The equivalent resistance shall be calculated using the following formula:

$$\text{Noise} = \frac{E_{pn}}{0.001} \text{ ohms}$$

Where:

E_{pn} = the peak-noise signal voltage presented on the oscilloscope screen.

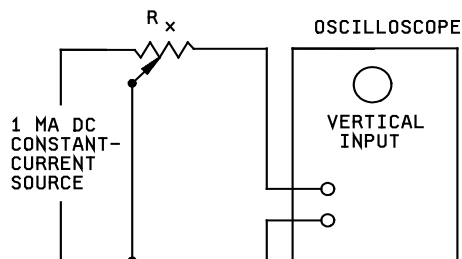
MIL-PRF-39015E
w/ Amendment 2

R_x TEST SPECIMEN
OSCILLOSCOPE OR TEST CIRCUIT BANDWIDTH: DC TO 500 KILOHERTZ MINIMUM.
MINIMUM INPUT IMPEDANCE: 1.0 MEGOHM AT 400 HERTZ.

FIGURE 3. Peak noise measuring circuit.

- * 4.8.4 Total resistance (see 3.10). Resistors shall be tested in accordance with MIL-STD-202-303. The following details shall apply:
- Measuring apparatus: Different types of measuring test equipment (multimeters, bridges, or equivalent) are permitted to use, provided the equipment is the same style, model, or if it can be shown that the performance of the equipment is equivalent to or better.
 - Measure energy for electronic test equipment: The measure energy applied to the unit under test shall not exceed 10 percent of the 25°C rated wattage times 1 second.
 - Test for bridges: Measurements of resistance shall be made using the test voltages specified in table X. The test voltage chosen, whether it is the maximum or a lower voltage which would still provide the sensitivity required, shall be applied across the terminals of the resistor. This same voltage shall be used whenever a subsequent resistance measurement is made.

TABLE X. Total resistance test voltages.

Resistance, nominal	Test potential
Ohms	Volts
10 to 100 inclusive	1.5
100 to 1,000 inclusive	3.0
Over 1,000 to 20,000 inclusive	10.0

4.8.4.1 Total resistance. Total resistance shall be measured as specified in 4.8.4, between the resistance element end terminals (terminal 1 and terminal 3 of figure 1), with the contact arm positioned against a stop. The positioning of the contact arm and terminal shall be the same for all subsequent measurements of the total resistance on the same specimen (see 3.10.1).

4.8.4.2 Absolute minimum resistance. The contact arm shall be positioned at one end of the resistance element, so that a minimum value of resistance shall be measured as specified in 4.8.4 between the contact arm and the corresponding end terminal. The same procedure shall be followed for the other end of the resistance element. Rated current through the resistance element shall not be exceeded during this measurement (see 3.10.2).

MIL-PRF-39015E
w/ Amendment 2

4.8.4.3 End resistance. The contact arm shall be positioned at the extreme counterclockwise limit of mechanical travel, and the resistance shall be measured as specified in 4.8.4 between the contact arm and the corresponding end terminal. The contact arm shall be positioned at the extreme clockwise limit of mechanical travel, and the resistance shall be measured as specified in 4.8.4 between the contact arm and corresponding end terminal. During this test, precaution shall be taken to insure that rated current of the resistance element is not exceeded. Clockwise or counterclockwise signifies the direction of rotation of the lead screw when the resistor is viewed from the screw head (see 3.10.3).

4.8.5 Immersion (not applicable to "L" type terminal) (see 3.11). The surface of the resistor shall be cleaned of any foreign matter immediately before immersion.

- a. Precondition: Precondition resistors in an oven at $125^{\circ}\text{C} \pm 5^{\circ}\text{C}$ for 13 minutes ± 2 minutes, or use a fluorocarbon bath maintained at $125^{\circ}\text{C} \pm 5^{\circ}\text{C}$ for a period of one and one-half minutes \pm one-half minute. Upon completion of precondition, allow resistors to stabilize to room temperature for approximately 13 minutes ± 2 minutes.
- b. Immersion: Resistors shall be tested in accordance with the following procedure:
 - (1). The resistors shall be immersed (not to exceed 30 samples) into a bath of fluorocarbon held at $85^{\circ}\text{C} \pm 5^{\circ}\text{C}$, -0°C for a period of 60 seconds ± 5 seconds. (stabilization & observation cycle). The resistors under test shall be completely submerged in the bath, with no part at a depth of less than 1 inch (2.54cm).
 - (2). Following the stabilization cycle, the resistors shall remain submerged and be shaken for a maximum of 5 seconds. (Agitation & trapped air removal cycle).
 - (3). The resistors shall remain in the bath for a period of 60 seconds ± 5 seconds to complete the test. (Final observation cycle; Total test time = 125 seconds, nominal). During the test sequence, visually examine resistors for inadequate seals, as evidenced by a continuous stream of bubbles emanating from any concentrated point on the resistor.
 - (4). If all resistor test samples pass immersion requirements as outlined in 3.12, Isolate 5 random resistors for Part C preconditioning and dye penetrant test.
- c. Dye penetrant: A 5 piece sample of the product exhibiting inconclusive evidence of compliance to immersion requirements (see 3.11) shall be preconditioned in an oven stabilized at $125^{\circ}\text{C} \pm 5^{\circ}\text{C}$ for 13 minutes ± 2 minutes, or preconditioned in a fluorocarbon bath maintained at $125^{\circ}\text{C} \pm 5^{\circ}\text{C}$ for 1 minute ± 5 seconds and immediately upon removal (within 5 seconds) shall be submerged in a dye penetrant solution for 30 seconds minimum. The dye penetrant solution shall consist of 0.1 gram per liter, or equivalent, of a solution stain dye such as crystal violet dissolved in deionized water maintained at room ambient temperature. Upon removal from the dye solution, the sample shall be held at room ambient temperature. Upon removal from the dye solution, the sample shall be held at room temperature until external surfaces are dry. The sample shall then be carefully opened and examined under 10X to 30X for evidence of the dye penetrant into the sealed cavity. Evidence of such penetration verifies loss of immersion seal and lack of such evidence verifies compliance to the requirements.

4.8.6 Continuity (see 3.12). The lead screw actuator shall be rotated at a uniform rate such that the wiper traverses the effective electrical travel in both directions within 1.250 minutes. During rotation a electrical device shall be connected between the wiper and either end terminal and monitored for smooth and directional change in voltage or resistance. Precaution shall be exercised to prevent excessive current flow in the resistor during test. There shall be no ohmmeter discontinuity upon reversal of direction of lead screw (see 3.12).

4.8.7 Actual effective electrical travel (see 3.13). The actual effective electrical travel, which is the number of turns of the lead screw in which a change in contact arm position gives a measurable change in voltage output, shall be measured by placing the resistor in a device and circuit which will indicate both mechanical position of the lead screw and voltage output.

MIL-PRF-39015E
w/ Amendment 24.8.8 Dielectric withstanding voltage (see [3.14](#)).

- * 4.8.8.1 Atmospheric pressure. Resistors shall be tested in accordance with [MIL-STD-202-301](#). The following details shall apply:
 - a. Special preparations: Resistors shall be mounted on metal plates of sufficient size to extend beyond the resistor extremities, and in such a manner that measurements can be made between the terminals tied together and any other external metal parts.
 - b. Magnitude of test voltage: 900 volts rms.
 - c. Nature of potential: From an alternating current (ac) supply at commercial line frequency and waveform.
 - d. Points of application of test voltage: Between the resistor terminals connected together and the metal portions of the resistors and metal mounting plate.
 - e. Examinations and measurements: During the tests, the leakage current shall be monitored and the resistors examined for evidence of arcing and breakdown. At the conclusion of the test, resistors shall be examined for evidence of damage.

- * 4.8.8.2 Barometric pressure. Resistors shall be tested in accordance with [MIL-STD-202-105](#). The following details and exceptions shall apply:
 - a. Method of mounting: As specified in [4.8.8.1a](#).
 - b. Test condition: C.
 - c. Period of time at reduced pressure prior to application of potential: One minute.
 - d. Test during subjection to reduced pressure: A potential of 350 volts rms from an ac supply at commercial line frequency and waveform shall be applied for 1 minute.
 - e. Points of application: As specified in [4.8.8.1d](#).
 - f. Examinations and measurements: As specified in [4.8.8.1e](#).

- * 4.8.9 Insulation resistance (see [3.15](#)). Resistors shall be tested in accordance with [MIL-STD-202-302](#). The following details shall apply:
 - a. Special preparation: As specified in [4.8.8.1a](#).
 - b. Test condition: A or B, whichever is more practicable.
 - c. Points of measurement: As specified in [4.8.8.1d](#).

4.8.10 Torque (see [3.16](#)).

4.8.10.1 Operating (see [3.16.1](#)). The maximum operating torque required to move the contact arm on the resistive element shall be determined at approximately 10 percent, 50 percent, and 90 percent of the actual effective electrical travel by the torque wrench or by any other method acceptable to the government.

4.8.10.2 Clutch (see [3.16.2](#)). The contact arm shall be adjusted to each extreme limit of mechanical travel, and sufficient torque shall be applied to the lead screw actuator to permit the contact arm to idle for 25 complete mechanical turns of the lead screw actuator. During idle, an electrical indicating device connected between the contact arm terminal and the adjacent end terminal shall be observed for electrical continuity. After idle, the lead screw actuator shall be rotated in the opposite direction and the indicating device observed to determine if the contact arm reversed direction without ohmmeter discontinuity.

MIL-PRF-39015E
w/ Amendment 2

* 4.8.11 Thermal shock (see [3.17](#)). Resistors shall be tested in accordance with [MIL-STD-202-107](#). The following details and exceptions shall apply:

- a. Test condition: B.
- b. Measurement before cycling: Total resistance and setting stability shall be measured as specified in [4.8.4.1](#) and [4.8.11.1](#), respectively.
- c. Measurements after cycling: Setting stability, total resistance, and continuity shall be measured as specified in [4.8.11.1](#), [4.8.4.1](#), and [4.8.6](#), respectively.
- d. Examination after test: Resistors shall be examined for evidence of mechanical damage.

4.8.11.1 Setting stability. The contact arm shall be set at approximately 40 percent of the actual effective electrical travel. An adequate dc test potential shall be applied between end terminals. The voltage between the end terminals, and the voltage between one end terminal and the contact arm, shall be measured and applied to the following formula:

$$\text{Setting stability (in percent)} = \frac{E1 \times 100}{E2}$$

where:

- E1 = Voltage across one end terminal and the contact arm terminal.
E2 = Voltage across the end terminals.

The difference between the initial measurement made before the environmental test and the measurement made after the test indicates the setting stability in percent.

* 4.8.12 Solderability (applicable to terminals P, W, X, and Y) (see [3.18](#)). Resistors shall be tested in accordance with [MIL-STD-202-208](#). The 3 pin terminals of each resistor shall be tested.

* 4.8.13 Resistance temperature characteristic (see [3.19](#)). Resistors shall be tested in accordance with [MIL-STD-202-304](#). The following details shall apply:

- a. Test temperatures: As specified in [table XI](#).
- b. Measurements at the end of each period: Total resistance shall be measured as specified in [4.8.4.1](#), (wiper against stop, measured through end terminals) at temperature maintained during the period.

MIL-PRF-39015E
w/ Amendment 2TABLE XI. Resistance-temperature characteristics.

Sequence		Temperature <u>±3°C</u>	
1		25	<u>1/</u>
2	<u>2/</u>	-15	
3		-55	
4		25	<u>1/</u>
5	<u>2/</u>	65	
6		150	

1/ This temperature shall be considered the reference temperature for each of the succeeding temperatures.

2/ Not applicable in conformance inspection.

NOTE: At the option of the manufacturer, the reverse sequence may be as follows:

1:	25°C	± 3°C
2:	65°C	± 3°C
3:	150°C	± 3°C
4:	25°C	± 3°C
5:	-15°C	± 3°C
6:	-55°C	± 3°C

* 4.8.14 Moisture resistance (see 3.20). Resistors shall be tested in accordance with MIL-STD-202-106. The following details and exceptions shall apply:

- a. Mounting: Clamped, or otherwise mounted with the terminals exposed on a stainless steel panel of sufficient size to extend beyond the resistor extremities, and in such a manner as to allow electrical connections to be made to the terminals. Mounting means shall also be provided for the insulation resistance test (see 4.8.8.1a).
- b. Initial measurement: Immediately following the initial drying period, total resistance shall be measured as specified in 4.8.4.1.
- c. Steps 7a and 7b are not applicable.
- d. Polarization and loading voltage: The resistors shall be divided in two equal groups; one group shall be subjected to polarization and the other group to load.
 - (1) Polarization: During steps 1 to 6 inclusive, a 100 volt dc potential shall be applied with the positive lead connected to the resistor terminals tied together, and the negative lead connected to the mounting plate.
 - (2) Loading voltage: During the first two hours of steps 1 and 4, a dc potential equivalent to 100 percent rated wattage, but not exceeding the maximum rated voltage (see 3.1), shall be applied to the resistors.
- e. Test procedure: The moisture resistance cycling requirements shall be as follows: For qualification inspection – 20 cycles; for group B inspection – 10 cycles.
- f. Final measurements: Upon completion of steps 6 of the final cycle, the resistors shall be removed from the chamber and air dried for one half hour at room ambient conditions. Samples shall not be subjected to forced air drying. The total resistance and insulation resistance shall then be measured (30 minutes to 60 minutes after removal from the humidity chambers), as specified in 4.8.4.1 and 4.8.9, respectively. The subsequent 24-hour conditioning period and measurements do not apply.
- g. Examination after test: Resistors shall be examined for evidence of mechanical damage.

MIL-PRF-39015E
w/ Amendment 2

- * 4.8.15 Shock (specified pulse) (see 3.21). Resistors shall be tested in accordance with MIL-STD-202-213. The following details and exceptions shall apply:
- a. Mounting means: Resistors shall be mounted by their normal mounting means, with their bodies restrained from movement on an appropriate mounting fixture. The mounting fixture shall be constructed in such a manner as to insure that the mounting supports remain in a static condition with reference to the shock test table. Resistors shall be mounted in relation to the test equipment in such a manner that the stress applied is in the direction which would be considered most detrimental.
 - b. Test leads: Test leads used during this test shall be no longer than average wire gauge (AWG) size 22 stranded wire, so that the influence of the test lead on the resistor shall be held to a minimum. The test lead length shall be no longer than necessary.
 - c. Measurements before shock: Total resistance and setting stability shall be measured as specified in 4.8.4.1 and 4.8.11.1, respectively.
 - d. Test condition: I.
 - e. Measurement during shock: Each resistor shall be monitored to determine electrical discontinuity of the resistance element, and between the contact arm and element, by a method that shall at least be sensitive enough to monitor or register, automatically, any electrical discontinuity of 0.1 millisecond or greater duration.
 - f. Measurement after shock: Setting stability and total resistance shall be measured as specified in 4.8.11.1 and 4.8.4.1, respectively.
 - g. Examination after shock: Resistors shall be examined for evidence of mechanical damage.
- * 4.8.16 Vibration, high frequency (see 3.22). Resistors shall be tested in accordance with MIL-STD-202-204. The following details and exceptions shall apply:
- a. Mounting: As specified in 4.8.15a.
 - b. Test leads: As specified in 4.8.15b.
 - c. Measurement before vibration: As specified in 4.8.15c.
 - d. Test condition: D.
 - e. Measurement during vibration: As specified in 4.8.15e.
 - f. Measurement after vibration: As specified in 4.8.15f.
 - g. Examination after vibration: Resistors shall be examined for evidence of mechanical damage.
- * 4.8.17 Salt spray (corrosion) (see 3.23). Resistors shall be tested in accordance with MIL-STD-202-101. The following details shall apply:
- a. Special mounting: As specified in 4.8.14a.
 - b. Test condition: A.
 - c. Examination after exposure: Resistors shall be examined for corrosion and mechanical operation.

MIL-PRF-39015E
w/ Amendment 2

- * 4.8.18 Resistance to soldering heat (applicable to terminal types P, W, X, and Y) (see 3.24). Resistors shall be tested in accordance with MIL-STD-202-210. The following details shall apply:
- Measurement before test: Total resistance shall be measured as specified in 4.8.4.1.
 - Test condition: A.
 - Measurement after test: One hour after completion of test, the total resistance shall be measured as specified in 4.8.4.1. Resistors shall then be examined for evidence of mechanical damage.
- 4.8.19 Low temperature operation (see 3.25).
- 4.8.19.1 Mounting. Resistors shall be mounted in such a manner as to allow electrical connections to be made to the terminals.
- 4.8.19.2 Procedure. Total resistance shall be measured as specified in 4.8.4.1. The resistors shall be placed in a chamber at room temperature. The temperature shall be gradually decreased to $-55^{\circ}\text{C} +0^{\circ}\text{C}$, -5°C within a period of not less than one and one-half hours. For conformance inspection only, and at the option of the manufacturer, the resistors may be placed in the chamber when the chamber is already at the extreme low temperature. After one hour of stabilization at this temperature, setting stability shall be measured as specified in 4.8.11.1. Full rated continuous working voltage (see 3.1 and 3.7) shall be applied for 45 minutes. The resistors may be loaded individually or in parallel. Fifteen minutes $+5$ minutes, -0 minutes after removal of voltage, setting stability shall be measured as specified in 4.8.11.1. The temperature in chamber shall be gradually increased to room temperature within a period of not more than 8 hours. The resistors shall be removed from the chamber and maintained at a temperature of $25^{\circ}\text{C} \pm 5^{\circ}\text{C}$ for a period of approximately 24 hours. Total resistance shall be measured as specified in 4.8.4.1. Resistors shall then be examined for evidence of mechanical damage.
- 4.8.20 Low temperature storage (for qualification only) (see 3.26).
- 4.8.20.1 Mounting. Resistors shall be mounted by their normal mounting means and in such a position with respect to the air stream that the mounting offers substantially no obstruction to the flow of air across and around the resistors.
- 4.8.20.2 Procedure. Total resistance shall be measured as specified in 4.8.4.1. Within one hour after this measurement, the resistor shall be placed in a cold chamber at a temperature of $-65^{\circ}\text{C} \pm 2^{\circ}\text{C}$ for a period of 72 hours $+8$ hours, -0 hours. The resistors shall then be removed from the chamber and maintained at a temperature of $25^{\circ}\text{C} \pm 5^{\circ}\text{C}$ until thermal stabilization is achieved. Total resistance shall be measured as specified in 4.8.4.1. Resistors shall be examined for evidence of mechanical damage.
- 4.8.21 High temperature exposure (see 3.27).
- 4.8.21.1 Mounting. Resistors shall be mounted in such a manner as to allow electrical connections to be made to the terminals.
- 4.8.21.2 Procedure. Total resistance and setting stability shall then be measured as specified in 4.8.4.1 and 4.8.11.1, respectively. The resistors shall then be exposed to an ambient temperature of $150^{\circ}\text{C} +5^{\circ}\text{C}$, -0°C for a period of 1,000 hours ± 8 hours. Not less than 2 hours after the end of the exposure period, setting stability and total resistance shall be measured as specified in 4.8.11.1 and 4.8.4.1, respectively. Dielectric withstanding voltage (at atmospheric pressure), and insulation resistance shall be measured as specified in 4.8.8.1 and 4.8.9, respectively. Resistors shall be examined for evidence of mechanical damage.

MIL-PRF-39015E
w/ Amendment 24.8.22 Integrity of shaft (see 3.28).

4.8.22.1 Mounting. Resistors shall be mounted in such a manner as to allow electrical connections to be made to the terminals.

4.8.22.2 Pull force. A force of 5 pounds shall be applied along the axis of the operating shaft away from the body of the resistor. The force shall be maintained for a minimum of 1 minute.

4.8.22.3 Perpendicular. A force of 2 pounds shall be applied in a direction perpendicular to the axis of the operating shaft for a minimum of 1 minute.

4.8.22.4 Examination after test. Resistors shall be examined for evidence of shaft breakage.

4.8.23 Rotational life (see 3.29).

4.8.23.1 Mounting. Resistors shall be mounted in such a manner as to allow electrical connections to be made to the terminals and concurrent contact arm actuation of each "pair" of resistors. The resistors shall be ganged in pairs, and each pair shall be connected in series, as shown in figure 4, so that a nominally constant current flows through the resistors, irrespective of the contact arm position during the turning of the operating shaft.

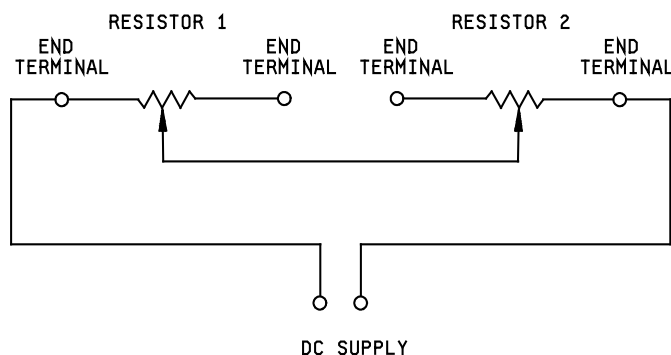

FIGURE 4. Rotational life test circuit.

4.8.23.2 Procedure. Total resistance shall be measured as specified in 4.8.4.1. A dc potential, equivalent to that required to dissipate rated wattage across the entire resistive element of resistors having the same nominal total resistance as those under test, shall then be applied as shown in figure 4. The lead screw actuators shall be continuously cycled through 90 percent to 100 percent of the actual effective electrical travel, at the rated one cycle for 2.5 minutes, for a total of 200 cycles. A cycle shall consist of travel through 90 percent to 100 percent of actual effective electrical travel and return to the starting point. At no time during this test shall the contact arm be allowed to idle at either end of the travel. After rotation, total resistance shall be measured as specified in 4.8.4.1. Resistors shall then be examined for evidence of mechanical damage.

4.8.24 Terminal strength (see 3.30).

* 4.8.24.1 Pull (applicable to all terminal types). Resistors shall be tested in accordance with MIL-STD-202-211. The following detail and exception shall apply:

- a. Test condition A: Applied force 2 pounds. Resistors clamped by the resistor body, force applied to each lead individually.
- b. Measurement after test: Resistors shall be examined for evidence of mechanical damage, and tested for electrical continuity.

MIL-PRF-39015E
w/ Amendment 2

- * 4.8.24.2 Push (applicable to all terminals except type L). Resistors shall be tested in accordance with [MIL-STD-202-211](#). The following detail and exception shall apply:
- a. Test condition: A, except force shall be applied in the direction towards the resistor body.
Applied force: 2 pounds. Resistors clamped by the resistor body, force applied to each terminal individually.
 - b. Measurement after test: Resistors shall be examined for evidence of mechanical damage, and tested for electrical continuity.
- 4.8.24.3 Bend (applicable to terminal types P, W, X, and Y). Resistors shall be firmly clamped and each terminal shall be bent through 90 degrees at a point 0.125 inch from the body of the resistor, with the radius of the curvature at the bend approximately 0.0625 inch. The pin shall be returned to the original position, bent 90 degrees in the opposite direction, and again returned to the original position. At the conclusion of the test, the resistors shall be examined for evidence of mechanical damage and tested for electrical continuity.
- * 4.8.25 Life (see 3.31). Resistors shall be tested in accordance with [MIL-STD-202-108](#). The following details and exceptions shall apply:
- a. Method of mounting: Resistors shall be mounted by their normal mounting means, on a 0.0625 inch thick, glass base, epoxy laminate. The resistors shall be so arranged that the temperature of any one resistor shall not appreciably influence the temperature of any other resistor. There shall be no circulation of air over the resistors other than that caused by heat of the resistors.
 - b. Test temperature and tolerance: 85°C ±5°C.
 - c. Initial measurement: Measurements may be made inside or outside the chamber.
 - (1) Inside the chamber: When measurements are to be made inside the chamber, the initial total resistance shall be measured between the clockwise terminal and the wiper for 50 percent of the sample units, and between the counterclockwise terminal (see [figure 1](#)) and the wiper for the remaining 50 percent of the sample units. The wiper shall be positioned at 95 percent ±2 percent of the total active element in each case. Resistance measurements shall be made after units have been stabilized at 85°C ±5°C for at least 8 hours. This initial measurement shall be used as the reference temperature for all subsequent measurements under the same conditions.
 - (2) Outside the chamber: When measurements are to be made outside the chamber, the initial total resistance shall be measured between the clockwise terminal and the wiper for 50 percent of the sample units, and between the counterclockwise terminal (see [figure 1](#)) and the wiper for the remaining 50 percent of the sample units. The wiper shall be positioned at 95 percent ±2 percent of the total active element in each case. Resistance measurements shall be made after units have been stabilized at room temperature for at least 8 hours. This initial measurement shall be used as the reference temperature for all subsequent measurements under the same conditions.
 - d. Operating conditions: Rated dc or ac continuous working voltage (RCWV) at commercial line frequency and waveform shall be applied intermittently to the wiper and active terminal of the resistor such that 95 percent ±2 percent of the rated power (see [3.1](#)) is dissipated by the resistor. The voltage shall be applied to the resistor, one and one-half hours "on" and one-half hours "off" for time duration specified in [4.8.25f](#) at the test temperature. Adequate precaution shall be taken to monitor the constant voltage on the resistor.
 - e. Test condition: 2,000 hours for qualification with all samples continued to 10,000 hours.

MIL-PRF-39015E
w/ Amendment 2

f. Measurements during test:

- (1) Qualification inspection: Resistance (see 4.8.4), shall be measured at the end of the 0.5 hour "off" periods after 168 hours +72 hours, -24 hours; 504 hours +72 hours, -24 hours; 1,008 hours +72 hours, -24 hours; and 2,016 hours +96 hours, -24 hours have elapsed. Units continued on test shall be measured at intervals above 2,000 hours in accordance with 4.8.25f (2).
- (2) Extended life testing: Resistance (see 4.8.4), shall be measured at the end of the 0.5 hour "off" periods after 168 hours +72 hours, -24 hours; 504 hours +72 hours, -24 hours; 1,008 hours +72 hours, -24 hours; 2,016 hours +96 hours, -24 hours, and every 2,000 hours +96 hours, -24 hours thereafter, until the required extended life period (10,000 hours), have elapsed. Measurements shall be made as near as possible to the specified time but may be adjusted so that measurements need not be made during other than normal working days.
- (3) Measurements outside of chamber: When measurements are made outside the chamber, resistors shall be outside of the chamber for a minimum of 45 minutes and stabilized at room temperature before measurement.

g. Examination after test: Resistors shall be examined for evidence of mechanical damage.

* 4.8.26 Resistance to solvent (see 3.32). Resistors shall be tested in accordance with MIL-STD-202-215. The following details shall apply:

- a. The marked portion of the resistor body shall be brushed.
- b. The number of sample units shall be as specified in table V and table IX, as applicable.
- c. Resistors shall be examined for mechanical damage and legibility of markings.

4.8.27 Fungus (see 3.33). Resistors shall be tested in accordance with method 508 of MIL-STD-810. Resistors shall be examined for evidence of fungus.

5. PACKAGING

5.1 Packaging. For acquisition purposes, the packaging requirements shall be as specified in the contract or order (see 6.2). When packaging of materiel is to be performed by DoD or in-house contractor personnel, these personnel need to contact the responsible packaging activity to ascertain packaging requirements. Packaging requirements are maintained by the Inventory Control Point's packaging activities within the Military Service or Defense Agency, or within the military service's system commands. Packaging data retrieval is available from the managing Military Department's or Defense Agency's automated packaging files, CD-ROM products, or by contacting the responsible packaging activity.

6. NOTES

(This section contains information of a general or explanatory nature that may be helpful, but is not mandatory).

6.1 Intended use. Resistors covered by this specification are intended for use in electronic equipment, and are used for matching, balancing, adjusting circuit variables in computers, telemetering equipment, and other special applications.

MIL-PRF-39015E
w/ Amendment 2

6.2 Acquisition requirements. Acquisition documents should specify the following:

- a. Title, number, date of this specification, the applicable associated specification, and the complete PIN (see 1.2.1).
- * b. Unless otherwise specified (see 2.1), the versions of the individual documents referenced will be those in effect on the date of release of the solicitation.
- c. Packaging requirements (see 5.1).
- d. Allowable substitution (see 3.34.2).

- * 6.3 Qualification. With respect to products requiring qualification, awards will be made only for products which are, at the time of award of contract, qualified for inclusion in Qualified Product List [QPL-39015](#) whether or not such products have actually been so listed by that date. The attention of the contractors is called to these requirements, and manufacturers are urged to arrange to have the products that they propose to offer to the Federal Government tested for qualification in order that they may be eligible to be awarded contracts or orders for the products covered by this specification. The activity responsible for the QPL is the US Army Communications - Electronics Research Development and Engineering Center (CERDEC), ATTN: RDER-PRO, Aberdeen Proving Ground, Bldg. 6010 K-130, MD 21005; however, information pertaining to qualification of products may be obtained from the DLA Land and Maritime, ATTN: VQP, P.O. Box 3990, Columbus, OH 43218-3990. An online listing of products qualified to this specification may be found in the Qualified Products Database (QPD) at <https://assist.dla.mil>.

6.4 Selection and use information. Equipment designers should refer to [MIL-HDBK-199](#), "Resistors, Selection and Use of", for a selection of standard resistor types and values for new equipment design. All applications and use information concerning these resistors are also provided in MIL-HDBK-199.

6.4.1 Type designation. The type designation system for identifying these parts is as follows:

NOTE: This is for information only. For the correct PIN, see 1.2.1.

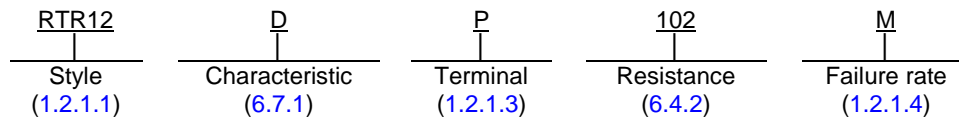

6.4.2 Resistance. The nominal total value expressed in ohms is identified by a three digit number; the first two digits represent significant figures and the last digit specified the number of zeros to follow. The following are examples of symbols for resistance values:

101 = 100 ohms
102 = 1,000 ohms

6.5 High resistance and voltage. Where voltages higher than 250 volts rms are present between the resistor circuit and grounded surface on which the resistor is mounted, or where the dc resistance is so high that the insulation resistance to ground is an important factor, secondary insulation to withstand the conditions should be provided between the resistor and mounting or between the mounting and ground.

6.6 Mounting of resistors. Resistors should not be mounted by their flexible wire leads. Mounting hardware should be used. Printed circuit types are frequently terminal mounted, although brackets may be necessary for high shock and vibration environment.

6.7 Resistance temperature characteristic. Consideration should be given to temperature rise and ambient temperature of resistors under operation in order to allow for the change in resistance due to resistance temperature characteristic.

MIL-PRF-39015E
w/ Amendment 2

6.7.1 Characteristic. The characteristic is identified by a single letter which identifies the resistance characteristic, maximum ambient temperature at rated wattage, and maximum ambient operating temperature (zero loads) in accordance with table XII.

TABLE XII. Characteristic.

Symbol	Maximum resistance temperature characteristic (referred to 25°C)	Maximum ambient temperature at rated wattage	Maximum ambient operating temperature
D	$\frac{\%}{^{\circ}\text{C}}$ ± 0.005 $\frac{\text{PPM}}{\pm 50}$	$\frac{^{\circ}\text{C}}{85}$	$\frac{^{\circ}\text{C}}{150}$

6.8 Reduction of power rating. When only a portion of the resistance element is engaged, the wattage is reduced in directly the same proportion as the resistance.

6.9 Stacking of resistors. When stacking of resistors, care should be taken to compensate for the added rise in temperature by derating the wattage rating accordingly.

6.10 MIL-PRF-27208 substitution data. Resistors of this specification, regardless of their FR designation, are substitutes for resistors of the same resistance value, tolerance, and performance characteristics specified in the inactive for new design specification of MIL-PRF-27208 as follows:

Substitute specification	Specification inactive for new design
MIL-PRF-27208/8	MIL-PRF-39015/1
MIL-PRF-39015/3	MIL-PRF-27208/9
MIL-PRF-39015/2	MIL-R-27208/4

Associated specification information is provided in the applicable specification sheet.

6.11 Lead material. Weldable lead material type N-2 of [MIL-STD-1276](#) has been deleted as a requirement from MIL-PRF-39015; the user's attention is directed to this change. Parts acquired to this specification are interchangeable with parts to all previous issues, when the application required a solderable lead. If weldable leads with specific materials are required, such requirement must be specified in the contract or order.

6.12 Retinning leads. If retinning (hot solder dip) of the leads is required, see [3.5.8](#).

6.13 Tin whisker growth. The use of alloys with tin content greater than 97 percent, by mass, may exhibit tin whisker growth problems after manufacture. Tin whiskers may occur anytime from a day to years after manufacture and can develop under typical operating conditions, on products that use such materials. Conformal coatings applied over top of a whisker-prone surface will not prevent the formation of tin whiskers. Alloys of 3 percent lead, by mass, have shown to inhibit the growth of tin whiskers. For additional information on this matter, refer to [ASTM-B545](#) (Standard Specification for Electrodeposited Coatings of Tin).

6.14 Caution note. The QPL manufacturer of the "L" termination of MIL-PRF-39015/2 has always used 100 percent tin plating on their internal tabs. Termination "L" is inactive for new design, and designers are cautioned on using the "L" termination for replacement purposes (see [6.13](#)).

MIL-PRF-39015E
w/ Amendment 2

6.15 Subject term (keyword listing).

Trimmer
Multi-turn
Linearly wound
Terminals
Wiper

6.16 Amendment notations. The margins of this specification are marked with asterisks to indicate modification generated by this amendment. This was done as a convenience only and the Government assumes no liability whatsoever for any inaccuracies in these notations. Bidders and contractors are cautioned to evaluate the requirements of this document based on the entire content irrespective of the marginal notations and relationship.

MIL-PRF-39015E
w/ Amendment 2

APPENDIX A

PROCEDURE FOR QUALIFICATION INSPECTION

A.1. SCOPE

A.1.1 Scope. This appendix details the procedures for submission of samples for qualification inspection of resistors covered by this specification. The procedure for extending qualification of the required sample to other resistors covered by this specification is also outlined herein. This appendix is a mandatory part of the specification. The information contained herein is intended for compliance only.

A.2. APPLICABLE DOCUMENTS

A.2.1 General. The documents listed in this section are specified in sections 3 and 4 of this specification. This section does not include documents cited in other sections of this specification or recommended for additional information or as examples. While every effort has been made to ensure the completeness of this list, document users are cautioned that they must meet all specified requirements documents cited in sections 3 and 4 of this specification, whether or not they are listed.

A.2.2 Government documents.

A.2.2.1 Specifications, standards, and handbooks. The following specifications, standards, and handbooks form a part of this document to the extent specified herein. Unless otherwise specified, the issues of these documents are those cited in the solicitation or contract.

DEPARTMENT OF DEFENSE STANDARDS

[MIL-STD-1276](#) - Leads for Electronic Component Parts.

* (Copies of these documents are available online at <http://quicksearch.dla.mil/>.)

* A.2.3 Order of precedence. Unless otherwise noted herein or in the contract, in the event of a conflict between the text of this document and the references cited herein (except for associated specifications, specification sheets, or MS sheets), the text of this document takes precedence. Nothing in this document, however, supersedes applicable laws and regulations unless a specific exemption has been obtained.

A.3. SUBMISSION

A.3.1 Product levels. Qualification of the C (non-ER) level is predicted upon meeting the ER qualification requirements for FR level M (see A.4.1) and the completion of the qualification lot through the 10,000 hour life test. The procedure for submitting samples to become qualified to the initial FR level M is specified in A.3.2.

A.3.2 Sample. The sample size and test routine for each style is as indicated in [table A-I](#). All samples are enclosed and have a minimum wire diameter not less than specified ([3.1](#)). After qualification has been granted, there will be no changes in material, design, or construction, without prior notification to the qualifying activity.

A.4. EXTENT OF QUALIFICATION

A.4.1 Extension of qualification. Qualification of a particular style and resistance value qualify a range of resistance values from the smallest value to the highest value inspected. Terminal "X" will qualify "W" and "W" will qualify "X". The extent of qualification between FR levels is as specified in [table A-II](#).

MIL-PRF-39015E
w/ Amendment 2

APPENDIX A

TABLE A-I. Qualification sample and test routine.

Extension of qualification	Resistance value	Terminal type tested ^{1/} _{2/}	Quantity	Test routine
Single terminal type submission over a range of resistance.	Highest	<u>Type submitted</u> ^{3/}	24	Group I, IA. All samples then divided equally for group III through group VI inclusive.
	Lowest		24	
	Highest		6	Group II.
	Highest		51	Group I, IA and group VII.
	Lowest		51	
			3	Group I, IA and group VIII, (any value, any terminal type).
P, W, X, and Y type over a range of resistance.	Highest	P (or Y)	24	Group I, IA. All samples then divided equally for group III through group VI inclusive.
	Lowest	P (or Y)	24	
	Highest	P(or Y)	6	Group II.
	Highest	W (or X)	6	
	Highest	W (or X)	24	Group I, IA. All samples then divided equally for group III through group VI inclusive.
	Highest	P (or Y)	26	Group I, IA and group VII.
	Lowest	P(or Y)	25	
Highest	W (or X)	26		
			25	
			3	Group I, IA and group VIII, (any value, any terminal type).
L, P, and Y type over a range of resistance.	Highest	P (or Y)	24	Group I, IA. All samples then divided equally for group III through group VI inclusive.
	Lowest	P (or Y)	24	
	Highest	P (or Y)	6	Group II.
	Highest	L	24	Group I, IA. All samples then divided equally for group III through group VI inclusive.
	Highest	L	26	Group I, IA and group VII.
	Lowest	L	25	
	Highest	P (or Y)	26	
			25	
			3	Group I, IA and group VIII, (any value, any terminal type).
L, P, W, X, and Y type over a range of resistance.	Highest	<u>Type submitted</u> ^{3/}	24	Group I, IA. All samples then divided equally for group III through group VI inclusive.
	Lowest		24	
	Highest	P(or Y)	6	Group II.
	Highest	W (or X)	6	
	Highest	L	24	Group I, IA. All samples then divided equally for group III through group VI inclusive.
	Highest	W (or Y)	24	
	Highest	L	17	Group I, IA and group VII.
	Highest	P(or Y)	17	
	Highest	W(or X)	17	
	Lowest	L	17	
Lowest	P(or Y)	17		
Lowest	W(or X)	17		
			3	Group I, IA and group VIII, (any value, any terminal type).

^{1/} Terminal type "X" will qualify "W" and conversely "W" will qualify "X".

^{2/} Terminal type "P" will qualify "Y" and conversely "Y" will qualify "P" by subjecting six sample units of any resistance value to visual and mechanical examination.

^{3/} L, P, W, X, or Y.

MIL-PRF-39015E
w/ Amendment 2

APPENDIX A

TABLE A-II. Extent of qualification between product levels.

Product level designator	Product level
S	R, P, M, C
R	P, M, C
P	M, C
M	C

A.5 SOLDER DIP (RETNING) LEADS

A.5.1 Solder dip (retinning) leads. The manufacturer (or their authorized category B or category C distributor) may solder dip/retin the leads of product supplied to this specification provided the solder dip process (see A.5.2 of this appendix A) or an equivalent process has been approved by the qualifying activity.

A.5.2 Qualifying activity approval. Approval of the solder dip process will be based on one of the following options:

- a. When the original lead finish qualified was hot solder dip lead finish 52 of MIL-STD-1276 (NOTE: The 200 microinch maximum thickness is not applicable). The manufacturer shall use the same solder dip process for retinning as is used in the original manufacture of the product.
- b. When the lead originally qualified was not hot solder dip lead finish 52 of MIL-STD-1276 as prescribed in A.5.2a, approval for the process to be used for solder dip shall be based on the following test procedure:
 - (1) Thirty samples of any resistance value for each style and lead finish are subjected to the manufacturers solder dip process. Following the solder dip process, the resistors are subjected to the dc resistance test and other group A electricals. No defects are allowed.
 - (2) Ten of the 30 samples are then subjected to the solderability test. No defects are allowed.
 - (3) The remaining 20 samples are subjected to the resistance to solder heat test followed by the moisture resistance test. No defects are allowed.

A.5.3 Solder dip/retinning options. The manufacturer (or their authorized category B or category C distributor) may solder dip/retin as follows:

- a. After the 100 percent group A screening tests: Unless otherwise approved (see 4.6.3.2.2) for lots subjected to this process, electrical measurements are required in accordance with group A, subgroup 2 (PPM) (NOTE: The manufacturer may solder dip/retin prior to the 100 percent electrical measurements of the group A, subgroup 1 tests). The percentage defective allowable (PDA) for the electrical measurements, shall be the subgroup 1 tests.
- b. As a corrective action, if the lot fails the group A solderability test: The lot may be retinned no more than two times. The lot after retinning shall be 100 percent screened for group A electrical requirements (total resistance). Any parts failing (lot not exceeding PDA for group A, subgroup 1, see 4.6.3.2.1) these screens shall not be supplied to this specification. If electrical failures exceeding 1 percent of the lot are detected after the second retinning operation, the lot shall not be supplied to this specification.
- c. After the group A inspection has been completed: Following the solder dip/retinning process, the electrical measurements required in group A, subgroup 1, 100 percent screening test shall be repeated on 100 percent of the lot. The PDA for the electrical measurements shall be as for the subgroup 1 tests. Following these tests, the manufacturer shall submit the lot to the group A solderability test as specified in 4.6.3.2.5.

MIL-PRF-39015E
w/ Amendment 2

Custodians:

Army - CR
Navy - EC
Air Force - 85
DLA - CC

Preparing activity:

Army - CR

Agent:

DLA - CC

Review activities:

Army - AR, AT, AV, CR4, EA, MI
Navy - AS, MC, OS
Air Force - 19, 99
Other - MDA

(Project 5905-2016-014)

NOTE: The activities listed above were interested in this document as of the date of this document. Since organizations and responsibilities can change, you should verify the currency of the information above using the ASSIST Online database at <https://assist.dla.mil>.