

INCH-POUND
------------

MIL-PRF-22097J  
 27 July 2007  
 SUPERSEDING  
 MIL-PRF-22097H  
 31 August 2000

PERFORMANCE SPECIFICATION  
 RESISTOR, VARIABLE, NONWIREWOUND,  
 (ADJUSTMENT TYPE)  
 GENERAL SPECIFICATION FOR

This specification is approved for use by all Departments  
 and Agencies of the Department of Defense.

## 1. SCOPE

1.1 Scope. This specification covers the general requirements for multiturn lead screw actuated and single turn nonwirewound, variable resistors with a contact bearing uniformly over the entire surface of the entire resistive element, when positioned by the actuator. These resistors are capable of full load operation (where maximum resistance is engaged) at a maximum ambient temperature of 70°C and 85°C, and are capable for continuous operation when properly derated, at a maximum temperature of 125°C and 150°C (see figure 1). These resistors have a resistance of ±10 percent (see 3.1).

## 1.2 Classification.

1.2.1 Part or Identifying Number (PIN). The PIN is in the following format, and as specified (see 3.1 and 6.2).

<u>RJ24</u>	<u>F</u>	<u>Y</u>	<u>103</u>
Style (1.2.1.1)	Characteristic (1.2.1.2)	Terminals (1.2.1.3)	Resistance (1.2.1.4)

1.2.1.1 Style. The style is identified by two letter symbol "RJ" followed by a two-digit number. The letters identify adjustment type, nonwirewound, variable resistors and the number identifies the physical size.

1.2.1.2 Characteristic. The characteristic is identified by a single letter in accordance with table I.

1.2.1.3 Terminals. The terminals are identified by a single letter in accordance with table II.

1.2.1.4 Resistance. The nominal resistance value expressed in ohms is identified by three digit number; the first two digits represent significant figures and the last digit specifies the number of zeros to follows. The following are examples of symbols for resistance values:

101	=	100 ohms
102	=	1,000 ohms
103	=	10,000 ohms
104	=	100,000 ohms
105	=	1,000,000 ohms

Comments, suggestions, or questions on this document should be addressed to Defense Supply Center, Columbus, ATTN: DSCC/VAT, Post Office Box 3990, Columbus, OH 43218-3990, or emailed to [Resistor@dla.mil](mailto:Resistor@dla.mil). Since contact information can change, you may want to verify the currency of this address information using the ASSIST Online database at <http://assist.daps.dla.mil>.

## MIL-PRF-22097J

TABLE I. Characteristics.

Requirement	Characteristic		
	A	C	F
Maximum resistance temperature characteristic (3.14) Percent per °C ppm/°C	See table III	±0.025 ±250	±0.010 ±100
Maximum ambient temperature at rated load <u>1/</u>	70°C	85°C	85°C
Maximum ambient temperature at zero load derating <u>1/</u>	125°C	150°C	150°C
Contact resistance variation (3.9)	2	See notes	
	Maximum percent change in total resistance		
Thermal shock (3.13)	3	2	1
Moisture resistance (3.15)	10	2	1
Shock (specific pulse) (3.16)	2	1	1
Vibration, high frequency (3.17)	2	1	1
Resistance to soldering heat (3.19)	2	1	1
Life (3.20)	10	3	2
Low temperature operation (3.21)	2	2	1
High temperature exposure (3.22)	12	3	2
Rotational life (3.23)	5	2	2

1/ see figure 1

## NOTES:

- Where "1" is specified for total resistance change, it is considered as ±1 percent +0.05 ohm.
- For characteristic "C" only, contact resistance variation will not exceed 3 percent or 20 ohms, whichever is greater.
- For characteristic "F" only, contact resistance variation will not exceed 3 percent or 3 ohms, whichever is greater.

TABLE II. Terminals.

Symbol	Type of terminal
L <u>1/</u>	Flexible, insulated wire leads.
P <u>2/</u>	Printed circuit pins.
S <u>3/</u>	Solder lugs.
W <u>4/</u>	Printed circuit pins (edge mounted).
X <u>5/</u>	Printed circuit pins (edge mounted, alternate configuration)
Y <u>6/</u>	Printed circuit pins (staggered)

1/ Applicable to all characteristics except characteristic A.2/ Applicable to all characteristics.3/ Applicable only to characteristic A, and to be used for replacement only.4/ Applicable to all characteristics. Available only essentially square styles. Pins extended from the edge 180 degrees away from the adjustment head and are parallel to the longitudinal axis of the adjustment screw.5/ Applicable to all characteristics. Available only essentially square styles. Pins extend from the edge 90 degrees away from the adjustment head and are perpendicular to the longitudinal axis of the adjustment screw.6/ Applicable only to style RJ12.

## MIL-PRF-22097J

TABLE III. Resistance temperature characteristic (characteristic A).

Nominal resistance (in ohms)				-55°C	-25°C	+25°C 1/	+55°C	+85°C	+125°C
				Percent					
100	to	500	Incl.	+4.5	+2.5	0	±1.0	±1.5	±4.0
1,000	to	5,000	Incl.	+5.5	+3.0	0	±1.0	±2.0	±5.0
10,000	to	50,000	Incl.	+7.0	+3.5	0	±1.0	±2.5	±6.0
100,000	to	500,000	Incl.	+8.0	+4.0	0	±1.5	±3.0	±6.5
1,000,000			Incl.	+10.0	+5.0	0	±1.5	±3.5	±8.0

1/ reference temperature

## 1.2.1.5 Example of PIN. The PIN RJ24FP103 signifies;

- RJ24 - Adjustment type, nonwirewound, variable, resistor of the dimensions specified (see 3.1).
- F - Having a characteristic signifying a maximum resistance temperature characteristic of 0.010 percent ( $\pm 100$  ppm) per $^{\circ}$ C, and a capability of operation at rated wattage at 85 $^{\circ}$ C maximum, and when derated, at 150 $^{\circ}$ C maximum (see figure 1).
- P - Having printed circuit pins
- 103 - Having a nominal total resistance value of 10,000 ohms.

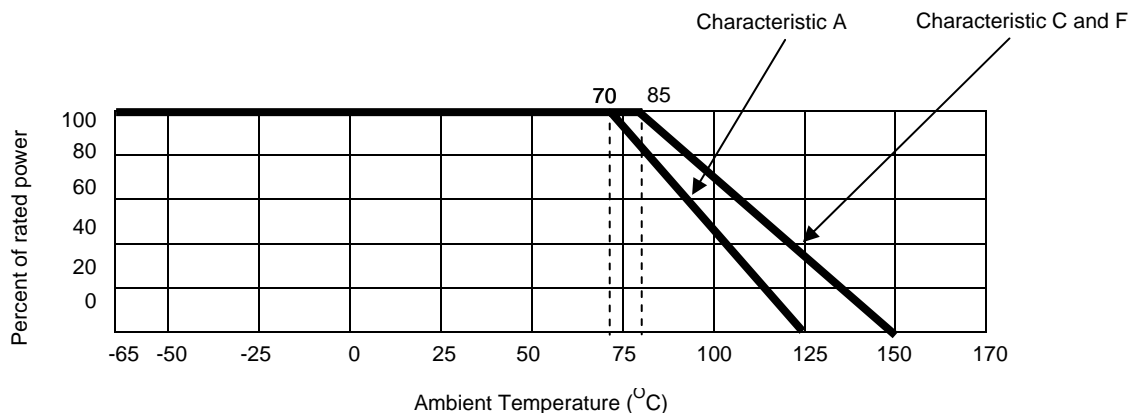

FIGURE 1. Derating curve for high ambient temperatures.

## MIL-PRF-22097J

## 2. APPLICABLE DOCUMENTS

2.1 General. The documents listed in this section are specified in [sections 3](#) and [4](#) of this specification. This section does not include documents cited in other sections of this specification or recommended for additional information or as examples. While every effort has been made to ensure the completeness of this list, document users are cautioned that they must meet all specified requirements documents cited in [sections 3](#) and [4](#) of this specification, whether or not they are listed.

2.2 Government documents.

2.2.1 Specifications, standards, and handbooks. The following specifications, standards, and handbooks form a part of this document to the extent specified herein. Unless otherwise specified, the issues of these documents are those cited in the solicitation ([see 6.2](#)).

## DEPARTMENT OF DEFENSE SPECIFICATION

(See [supplement 1](#) for list of specification sheets.)

[MIL-PRF-39035](#) - Resistor, Variable, Nonwirewound (Adjustment Type) Nonestablished Reliability, and Established Reliability, General Specification for.

## DEPARTMENT OF DEFENSE STANDARDS

[MIL-STD-202](#) - Test Methods Standard Electronics and Electrical Components Parts.  
[MIL-STD-810](#) - Environmental Engineering Considerations and Laboratory Tests.  
[MIL-STD-1285](#) - Marking of Electrical and Electronic Parts.

## DEPARTMENT OF DEFENSE HANDBOOKS

[FED-STD-H28](#) - Screw Thread Standards for Federal Services.

(Copies of these documents are available online at <http://assist.daps.dla.mil/quicksearch/> or <http://assist.daps.dla.mil> or from the Standardization Document Order Desk, 700 Robbins Avenue, Building 4D, Philadelphia, PA 19111-5094).

2.3 Non-Government publications. The following documents form a part of this document to the extent specified herein. Unless otherwise specified, the issues of the documents cited in the solicitation or contract ([see 6.2](#)).

## AMERICAN NATIONAL STANDARDS (ANS)

[J-STD-006](#) - Requirements for Electronic Grade Solder Alloys and Fluxed and Non-Fluxed Solid Solders for Electronic Soldering Applications

(DoD activities may obtain copies of American National Standard J-STD-006 from the Standardization Document Order Desk. Private sector and other Government agencies may purchase copies from the Institute for Interconnecting and Packaging Electronic Circuits (IPC) <http://www.ipc.org/>, 7380 N. Lincoln, Lincolnwood, IL 60646).

## INTERNATIONAL ORGANIZATION for STANDARDS (ISO)

[ISO 10012-1](#) - Equipment, Quality Assurance Requirements for Measuring - Part 1: Meteorological Confirmation System for Measuring Equipment.

(Copies of this document are available online at <http://www.iso.org/> or should be addressed to the American National Standards Institute, 11 West 42nd Street New York, NY 10036.)

MIL-PRF-22097J

## NATIONAL CONFERENCE OF STANDARDS LABORATORIES (NCSL)

NCSL Z540-1 - Laboratories, Calibration, and Measuring and Test Equipment.

(Copies of this document are available from <http://www.ncsli.org/> or from the National Conference of Standards Laboratories (NCSL) International, 1800 30th Street, Suite 305, Boulder, CO 80301-1026.)

2.4 Order of precedence. In event of a conflict between the text of this document and the references cited herein, the text of this document takes precedence. Nothing in this document, however, supersedes applicable laws and regulations unless a specific exemption has been obtained.

## 3. REQUIREMENTS

3.1 Specification sheets. The individual item requirements shall be as specified herein and in accordance with the applicable specification sheet. In the event of any conflict between the requirements of this specification and the specification sheet, the latter shall govern ([see 6.2](#)).

3.2 Qualification. Resistors furnished under this specification shall be products which are authorized by the qualifying activity for listing on the applicable qualified products list at the time of award of contract ([see 4.4](#) and [6.3](#)).

3.3 Material. The material shall be specified herein. However, when a definite material is not specified, a material shall be used which will enable the resistors to meet the performance requirements of this specification. Acceptance or approval of any constituent material shall not be construed as a guaranty of the acceptance of the finish product.

3.3.1 Plastic. Plastic laminates containing a cotton fabric base or plastic molding compounds containing a cotton or wood flour filler shall not be used. When not machined, plastic material shall have smooth, or polished surfaces. Surfaces that have not been sawed, cut, punched, or otherwise machined shall be smooth as practicable in accordance with good manufacturing practice.

3.3.2 Ferrous metals. Unless specifically approved by the Government, the use of ferrous material, with the exception of corrosion resistant steel and the resistance element material is prohibited.

3.4 Interface and physical dimension requirements. The resistors shall meet the interface and physical dimensions specified ([see 3.1](#)).

3.4.1 Resistance element. The resistance element shall be nonwirewound on a form which shall not char or break down as a result of the tests specified herein. The element shall be characterized by a continuous nature of the surface area or multiple paths of the resistance element to be contacted. Contact must be made over a continuous and unbroken resistance path.

3.4.2 Protective housing or enclosure. The resistance element of completed resistors shall be protected by a housing, or an enclosure, or both, which shall completely cover the exterior of the resistance element. The protective housing or enclosure shall be free from holes, fissures, chips, or other faults, and shall be such as to minimize the established of leakage paths between terminals, resulting from collection of moisture film on the exterior surface of the housing or enclosure. If housing is made from aluminum alloy, it shall be properly protected against corrosion and all fasteners shall be plated. Unplated copper alloys metals shall not be used in contact with aluminum.

3.4.3 Terminals. Terminals shall be as specified in [table III](#). All terminals shall be fastened securely. Terminals shall be protected by a corrosion resistant metallic coating, and all terminals or exposed portions of insulated wire shall be treated to facilitate soldering.

## MIL-PRF-22097J

3.4.3.1 Terminal identification and circuit diagram.3.4.3.1.1 Terminal identification.

3.4.3.1.1.1 Terminals P, S, W, X, and Y. For terminals P, S, W, X, and Y type resistors identification shall be by one of two methods. The numerals designating terminal identification may be marked adjacent to the terminals or the circuit diagram (see 3.4.3.1.2) may be used, provided that such identification clearly indicates the applicable terminals.

3.4.3.1.1.2 Terminals L. For terminal L type resistors, the insulation of the flexible leads shall be color coded as shown on figure 2.

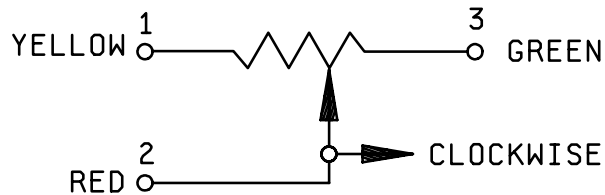

FIGURE 2. Circuit diagram.

3.4.3.1.2 Circuit diagram. The circuit diagram shall be marked on any surface of the resistor in a legible manner, as shown on figure 2.

3.4.3.1.3 Legibility. Marking shall remain legible after all test.

3.4.3.2 Solder dip (retinning) leads (not applicable to terminal L). The manufacturer may solder dip/retin the leads of product supplied to this specification provided the solder dip process (see appendix A) has been approved by the qualifying activity.

3.4.3.2.1 Tin plated finishes. The use of pure tin, as an underplate or final finish is prohibited both internally and externally. Tin content of resistor components and solder shall not exceed 97 percent, by mass. Tin shall be alloyed with a minimum of 3 percent lead, by mass (see 6.13).

3.4.4 Securing of screw thread assemblies. Screw thread assemblies shall not loosen as a result of the tests specified herein.

3.4.5 Operating shaft. The operating shaft shall be of corrosion resistant material with the head insulated from all electrical parts of the resistor. The operating shaft head shall be slotted as specified (see 3.1).

3.4.6 Contact arm assembly. Uniform contact pressure on the resistance element shall be maintained by positive pressure and shall permit smooth electrical and mechanical control of the resistor over the entire range. The moving contact shall have continuous electrical contact with its terminal throughout the entire mechanical travel and shall be insulated from the operating shaft head and case.

3.4.7 Mechanical limits.

3.4.7.1 Clutches (applicable only to multiturn lead-screw actuated units, unless otherwise specified) (see 3.1). Clutches shall be furnished to permit the contact arm to idle at either end of the resistance element without electrical or mechanical malfunctions (see 3.12.2).

## MIL-PRF-22097J

3.4.7.2 Stops (applicable to single turn units, unless otherwise specified) (see 3.1). Stops employed to limit the mechanical rotation of the contact arm assembly may be part of, but shall not complete an electrical circuit (see 3.12.3).

3.5 Power rating. The resistors shall have a power rating based on continuous full load operation at the ambient temperature specified for the applicable characteristic (see 3.1 and table I). The power rating is dependent on the ability of the resistors to meet the life requirements specified in 3.20. For temperatures in excess of those specified, the load shall be derated as shown on figure 1. Power ratings as specified (see 3.1) are applicable only when the maximum resistance is engaged in the circuit. When only a portion of the resistance element is engaged in the circuit, the power rating is reduced in approximately the same proportion as the resistance.

3.6 Voltage rating. The theoretical calculated rated continuous working voltage or the voltage equivalent to power rating (rated wattage) shall be determined from the following formula:

$$E = \sqrt{PR}$$

Where:

- E = Rated dc or root mean square (rms) continuous working voltage.
- P = Power rating.
- R = Nominal total resistance.

The rated voltage shall not exceed the maximum continuous working voltage (see 3.1).

### 3.7 DC resistance (see 4.6.2).

3.7.1 Total resistance. When measured as specified in 4.7.2.1, the total direct-current (dc) resistance shall not deviate from the specified nominal resistance (see 3.1) by more than  $\pm 10$  percent.

3.7.2 End resistance. When measured as specified in 4.7.2.2, the end resistance for all characteristics shall not exceed 20 ohms, or 2 percent of the total resistance, whichever is greater.

3.7.3 Resistance value deviations. All maximum deviations as specified in this section are to be considered absolute limits with the exception of the contact resistance adjustment.

3.8 Actual effective electrical travel. When resistors are tested as specified in 4.7.3, the number of turns of the operating shaft necessary for the contact arm to traverse the resistance element shall be as specified in (see 3.1).

3.9 Contact resistance variation. When measured as specified in 4.7.4, the contact resistance variation shall not exceed the applicable value specified in table I.

3.10 Dielectric withstanding voltage. When resistors are tested as specified in 4.7.5, there shall be no evidence of damage, arcing, or breakdown. The leakage current shall not exceed 1 milliamperere.

3.11 Insulation resistance. When resistors are tested as specified in 4.7.6, the insulation resistance shall not be less than 1,000 megohms.

### 3.12 Torque.

3.12.1 Operating. When resistors are tested as specified in 4.7.7.1, the torque required to move the contact arm shall be as specified (see 3.1).

3.12.2 Clutch (applicable only to multiturn lead screw actuated units, unless otherwise specified). When resistors are tested as specified in 4.7.7.2, the contact arm shall idle against the stop without electrical discontinuity or evidence of mechanical damage. The travel of the contact arm shall be capable of reversing direction.

## MIL-PRF-22097J

3.12.3 Stop (applicable only to single turn units, unless otherwise specified). When resistors are tested as specified in 4.7.7.3, they shall withstand the stop torque specified (see 3.1), without damage to the contact arm or stop.

3.13 Thermal shock. When resistors are tested as specified in 4.7.8, the change in total resistance shall not exceed the applicable value specified in table I. The change in setting stability shall not exceed 2 percent for characteristics A, and 1 percent for characteristic C and characteristic F. There shall be no electrical discontinuity or evidence of mechanical damage.

3.14 Resistance temperature characteristic. When resistors are tested as specified in 4.7.9 and 4.7.9.1, the resistance temperature characteristic, at each of the test temperatures, referred to an ambient temperature of 25°C, shall not exceed the applicable value specified in table I.

3.15 Moisture resistance. When tested as specified in 4.7.10, resistors shall meet the following requirements:

Total resistance:	Change shall not exceed the applicable value specified in table I.
Insulation resistance:	Shall not be less than 100 megohms.
Visual inspection:	There shall be no evidence of mechanical damage.

3.16 Shock (specified pulse). When resistors are tested as specified in 4.7.11, the change in total resistance shall not exceed the applicable value specified in table I. The change in setting stability shall not exceed 2 percent for characteristic A, and 1 percent for characteristic C and characteristic F. There shall be no electrical discontinuity or evidence of mechanical damage.

3.17 Vibration, high frequency. When resistors are tested as specified in 4.7.12, there shall be no electrical discontinuity, and resistors shall meet the following requirements:

Setting stability:	Change shall not exceed 2 percent for characteristic A, and 1 percent for characteristic C and characteristic F.
Total resistance:	Change shall not exceed the applicable value specified in table I.
Operating torque:	Shall not exceed 150 percent of the specified operating torque (see 3.1).
Visual inspection:	There shall be no evidence of mechanical damage.

3.18 Salt spray (corrosion). When resistors are tested as specified in 4.7.13, there shall be no appreciable corrosion.

3.19 Resistance to soldering heat (applicable to terminal types P, S, W, X, and Y only). When resistors are tested as specified in 4.7.14, the change in total resistance shall not exceed the applicable value specified in table I. There shall be no evidence of mechanical damage.



## MIL-PRF-22097J

3.20 Life. When tested as specified in 4.7.15, resistors shall meet the following requirements:

Resistance between end terminals, with the contact arm in the position for setting stability:	Change shall not exceed applicable value for total resistance specified in table I between the initial measurements and each of the succeeding measurements.
Setting stability:	Change shall not exceed 2 percent for characteristic A, and 1 percent for characteristic C and characteristic F.
Total resistance:	Change shall not exceed the applicable value specified in table I.
Dielectric withstanding voltage at (atmospheric pressure):	As specified in 3.10.
Operating torque:	Shall not exceed 150 percent of the specified operating torque (see 3.1).
Visual inspection:	There shall be no evidence of mechanical damage.

3.21 Low temperature operation. When resistors are tested as specified in 4.7.16, resistors shall meet the following requirements:

Setting stability:	Change shall not exceed 2 percent.
Operating torque:	Shall not exceed 150 percent of the specified operating torque (see 3.1).
Total resistance:	Change shall not exceed the applicable value specified in table I.
Visual inspection:	There shall be no evidence of mechanical damage.

3.22 High temperature exposure. When resistors are tested as specified in 4.7.17, resistors shall meet the following requirements:

Setting stability:	Change shall not exceed 2 percent.
Total resistance:	Change shall not exceed the applicable value specified in table I.
Operating torque:	Shall not exceed 150 percent of the specified operating torque.
Dielectric withstanding voltage (at atmospheric pressure):	As specified in 3.10.
Insulation resistance:	Shall not be less than 1,000 megohms.
Visual inspection:	There shall be no evidence of mechanical damage.

3.23 Rotational life. When resistors are tested as specified in 4.7.18, the change in total resistance shall not exceed the applicable value specified in table I. There shall be no evidence of mechanical damage.

3.24 Terminal strength. When resistors are tested as specified in 4.7.19, there shall be no evidence of mechanical damage, and resistors shall be electrically continuous.

## MIL-PRF-22097J

3.25 Solderability (applicable to terminal types P, W, X, and Y only). When resistors are tested as specified in 4.7.20, the dipped surface of the terminals shall be at least 95 percent covered with a new, smooth, continuous surface free from pin holes. The remaining 5 percent of the terminal surface shall show only pin holes, voids, or rough spots. These shall not be concentrated in one area. Bare base metal and areas where the solder dip has failed to cover the original coating are indications of poor solderability, and shall be cause for failure. In case of dispute, the percentage of coverage with pinholes or rough spots shall be determined by actual measurement of these areas, as compared to the total area.

3.26 Immersion (applicable to terminal types P, S, W, X, and Y only). When resistors are tested as specified in 4.7.21, no continuous stream of bubbles shall be emitted.

3.27 Fungus. All external materials shall be nonnutrient to fungus or shall be treated to retard fungus growth. The manufacturer shall verify by certification that all external materials are fungus resistant or shall test resistors as specified in 4.7.22. There shall be no evidence of fungus growth on the external surfaces.

3.28 Marking. Resistors shall be marked with the PIN and the manufacturer's name or code symbol. The circuit diagram shall be marked on the resistor as specified in 3.4.3.1. The location of the manufacturers code symbol shall be at the discretion of the manufacturer. Marking shall remain legible at the end of all tests. There shall be space between the symbols which comprise the PIN. If lack of space requires it, the PIN may be placed on two lines or on separate surfaces. In the event, the PIN shall be divided between the characteristic and terminal symbols, as shown in the following example:

RJ24F  
P103

3.29 Supplying to tighter resistance temperature characteristics. Parts qualified and marked to lower resistance temperature characteristics, with procuring activity approval, are substitutable for higher resistance temperature characteristics and shall not be remarked unless specified in the contract or purchase order (see 6.2) (see table IV).

TABLE IV. Characteristics.

Characteristic		Characteristic substitute
Symbol	ppm/ <sup>o</sup> C	
A	1/	F
F	±100	
C	±250	

1/ See table III.

3.30 Riveting. When riveting is required, the operation shall be carefully performed to insure that the rivets are tight and satisfactorily headed.

3.31 Solder, flux, and soldering. Materials and processes for soft soldering shall be as specified in 3.31.1 and 3.31.2.

3.31.1 Soft solder. Soft solder, when used for electrical connections, shall conform to composition type A of J-STD-006.

3.31.2 Flux and cleaning agents. Flux for soldering electrical connections shall be resin or resin and alcohol. No acid or acid salts shall be permitted for pretinning of electrical connections and for tinning of electrical circuits, but in no case shall acid or acid salts be use where they come into contact with insulation material. Where acid or acid salts are used, as permitted herein, they shall be completely neutralized and removed immediately after use.

## MIL-PRF-22097J

3.31.3 Process. Soldered connections shall be neat. There shall be no sharp points or rough spots surfaces resulting from heating. The solder shall feather out to a thin edge, indicating proper flowing and wetting action, and shall not be crystallized, overheated, or underheated. The minimum necessary amount of flux shall be used for electrical connections. Whenever practical, excess resin shall be removed with a wire brush and a dry cloth. Any resulting loose flakes of resin shall be removed. Insulation resistance material that has been subjected to heating during the soldering operation shall be undamaged and parts fastened thereto shall not have become loosened.

3.32 Welding and brazing. Where welding and brazing is employed, the electrical connections shall be mechanically secure and electrically continuous after welding or brazing. Where brazing is employed, only substantially noncorrosive fluxes shall be used, unless it can be shown that corrosive elements have been satisfactorily removed after brazing.

3.33 Recycling, recovered, or environmentally preferable materials. Recycled, recovered, or environmentally preferable materials should be used to the maximum extent possible provided that the material meets or exceeds the operational and maintenance requirements, and promotes economically advantageous life cycle costs.

3.34 Workmanship. Resistors shall be processed in a manner as to be uniform in quality and shall be free from holes, fissures, chip, and malformation. The leads shall be unbroken and not crushed or nicked, and the resistors shall be free from other defects that will affect life, serviceability, or appearance.

#### 4. VERIFICATION

4.1 Classification of inspections. The inspection requirements specified herein are classified as follows:

- a. Qualification inspection (see 4.4).
- b. Conformance inspection (see 4.6).

4.2 Test equipment and inspection facilities. The manufacturer shall establish and maintain a calibration system in accordance with [NCSL Z540-1](#), [ISO 10012-1](#), or equivalent system as approved by the qualifying activity.

4.3 Inspection conditions and precautions.

4.3.1 Inspection conditions. Unless otherwise specified herein, all inspections shall be in accordance with the test conditions specified in the "GENERAL REQUIREMENT" of [MIL-STD-202](#).

4.3.2 Precautions. Adequate precautions shall be taken during inspection to prevent condensation of moisture on resistors. Precautions shall also be taken to prevent damage by heat when soldering resistor leads to terminals.

4.4 Qualification. Qualification inspection shall be performed at a laboratory acceptable to the Government (see 6.3) on sample units produced with equipment and procedures normally used in production.

4.4.1 Sample size. The number of sample units comprising a sample of resistors to be subjected for qualification inspection shall be as in the appendix to this specification.

4.4.2 Inspection routine. Sample units with any terminal type shall be subjected to the qualification inspection specified in [table V](#), in the order shown. Thirty enclosed sample units shall be subjected to the inspection of group I. They shall then be divided into five groups of six units each, for groups II to VI, inclusive, and subjected to the inspection for their particular group. The remaining three enclosed sample units shall be subjected to the inspection of group VII only. The two unenclosed sample units shall be subjected only to the visual and mechanical inspection of group I. Five enclosed or unenclosed sample units shall be subjected to the fungus test in group VIII. Qualification shall be extended to other terminal types of the same style and characteristic by submission of samples to additional testing in accordance with [table A-1](#).

4.4.3 Failures. Failures in excess of those allowed in [table V](#) shall be cause for refusal to grant qualification.

## MIL-PRF-22097J

TABLE V. Qualification inspection 1/

Inspection	Requirement paragraph	Method Paragraph	Number of failures allowed 2/	
Visual and mechanical inspection 3/ 4/	3.1, 3.3 to 3.3.2, 3.4 to 3.4.3, 3.4.4 to 3.4.7 incl., 3.28 to 3.32 incl.	4.7.1	0	
<u>Group I</u> 4/ Total resistance 1/ Actual effective electrical travel End resistance Contact resistance variation Dielectric withstanding voltage Insulation resistance Torque Thermal shock	3.7.1 3.8 3.7.2 3.9 3.10 3.11 3.12 3.13	4.7.2.1 4.7.3 4.7.2.2 4.7.4 4.7.5 4.7.6 4.7.7 4.7.8		
<u>Group II</u> Resistance temperature characteristic 4/ Moisture resistance Contact resistance variation	3.14 3.15 3.9	4.7.9 and 4.7.9.1 4.7.10 4.7.4		
<u>Group III</u> Shock (specific pulse) Vibration, high frequency Contact resistance variation Salt spray (corrosion)	3.16 3.17 3.9 3.18	4.7.11 4.7.12 4.7.4 4.7.13		
<u>Group IV</u> Resistance to soldering heat (terminal types P, S, W, X, and Y) Life Contact resistance variation	3.19 3.20 3.9	4.7.14 4.7.15 4.7.4		1
<u>Group V</u> Low temperature operation High temperature exposure Contact resistance variation	3.21 3.22 3.9	4.7.16 4.7.17 4.7.4		
<u>Group VI</u> Rotational life Contact resistance variation Terminal strength	3.23 3.9 3.24	4.7.18 4.7.4 4.7.19		
<u>Group VII</u> Solderability (terminal types P, W, X, Y) Immersion (terminal types P, W, X, Y)	3.25 3.26	4.7.20 4.7.21		
<u>Group VIII</u> Fungus	3.27	4.7.22		0

1/ See table A-1.

2/ Failure of a single resistor in one or more tests of a group shall be charged as a single failure.

3/ Marking shall be considered defective only if marking is illegible. Marking shall remain legible at the end of all tests. Marking shall remain legible at the end of all tests. Marking is not applicable to unenclosed resistors.

4/ Nondestructive tests.

## MIL-PRF-22097J

4.5 Retention of qualification. Every 6 months, the manufacturer shall verify the retention of qualification to the qualifying activity. In addition, the manufacturer shall immediately notify the qualifying activity whenever the group B inspection results indicate failures of the qualified product to meet the requirements of this specification. Verification shall be based on meeting the following requirements:

- a. The manufacturer has not modified the design of the item.
- b. The specification requirements for the item have not been amended so far as to affect the character of the item.
- c. Lot rejection for group A inspection does not exceed the group A sampling plan.
- d. The requirements for group B inspection are met.

When group B requirements were not met and the manufacturer has taken corrective action satisfactory to the Government, group B inspection retesting shall be instituted.

4.6 Conformance inspection.

4.6.1 Inspection of product for delivery. Inspection of product for delivery shall consist of groups A and B inspection.

4.6.1.1 Inspection lot. Inspection lot as far as practicable, shall consist of all resistors of the same style and characteristic regardless of the resistance value (combining of all terminal types except L is acceptable) produced in a period not to exceed 30 days, produced under essentially the same conditions, and offered for inspection at one time.

4.6.2 Group A inspection. Group A inspection shall be as specified in [table VI](#). The tests shall be conducted in the order shown.

4.6.2.1 Sampling plan.

4.6.2.1.1 Subgroup 1. A sample of parts from each inspection lot shall be randomly selected in accordance with [table VII](#). If one or more defects are found, the lot shall be reworked or screened and defectives removed. After reworking or screening and removal of defects, a new sample of parts shall be randomly selected in accordance with [table VII](#). If one or more defects are found in this second sample, the lot shall be rejected and shall not be supplied to this specification.

4.6.2.1.2 Subgroup 2. A sample of parts from each inspection lot shall be randomly selected in accordance with [table VII](#). If one or more defects are found, the lot shall be reworked or screened and defectives removed. After reworking or screening and removal of defects, a new sample of parts shall be randomly selected in accordance with [table VII](#). If one or more defects are found in the second sample, the lot shall be rejected and shall not be supplied to this specification.

## MIL-PRF-22097J

TABLE VI. Group A inspection.

Inspection	Requirement Paragraph	Method Paragraph	Sampling plan
<u>Subgroup 1</u> <u>1/</u> Total resistance End resistance Contact resistance variation Immersion (terminal types P, W, X, Y)	3.7.1 3.7.2 3.9 3.26	4.7.2.1 4.7.2.2 4.7.4 4.7.21	4.6.2.1.1
<u>Subgroup 2</u> Visual and mechanical Inspection <u>2/</u>	3.1, 3.3 to 3.4.3 incl., 3.4.4 to 3.4.7 incl., 3.30 to 3.32	4.7.1	4.6.2.1.2
<u>Subgroup 3</u> <u>3/</u> Solderability (terminal types P, W, X, Y)	3.25	4.7.20	4.6.2.1.3

1/ 100 percent inspection may be used in lieu of sampling plan.

2/ Marking defects shall be charged only for illegible, incorrect, or incomplete marking. Any subsequent electrical defect shall not be charged as a marking defect.

3/ The manufacturer may request the deletion of the subgroup 3 solderability test, provided an in line process control system for assessing and assuring the solderability of leads can be validated and approved by the qualifying activity. Deletion of the test does not relieve the manufacturer from meeting this test requirement in case of dispute. If the design, material, construction, or processing of the part is changed or if there are any quality problems, the qualifying activity may require resumption of the test.

TABLE VII. Group A sampling plan.

Lot size	Subgroup 1 Sampling plan	Subgroup 2 Sampling plan
1 to 25	100 percent	3
26 to 50	100 percent	5
51 to 90	100 percent	6
91 to 150	90	7
151 to 280	125	10
281 to 500	192	11
501 to 1,200	192	15
1,201 to 3,200	192	18
3,201 to 10,000	192	22
10,001 to 150,000	294	29
150,001 to 500,000	345	29
500,001 and above	435	29

## MIL-PRF-22097J

4.6.2.1.3 Subgroup 3 (solderability). A sample of five parts from each inspection lot shall be selected and subjected to the subgroup 3 solderability test. If one or more defects, the lot shall be considered to have failed. As an option, the manufacturer may use electrical rejects from the subgroup 1 tests for all or part of the sample. If there are one or more defects, the lot is rejected. The manufacturer may use one of the following options for corrective action:

- a. Each production lot that was used to form the failed inspection lot shall be individually submitted to the solderability test. Production lots that pass the solderability test are available for shipment. Production lots failing the solderability test can be submitted to the solder dip procedure in 4.6.2.1.3b.
- b. The lot is submitted to a 100 percent solder dip using an approved solder dip process in accordance with the appendix. A subsequent solderability test shall then be performed. If the lot passes, it is available for shipment; if the lot fails, the manufacturer may perform the hot solder dip one additional time. If the lot fails to pass, the lot is considered rejected and shall not be supplied to this specification.

4.6.2.1.4 Disposition of samples. The solderability test is considered a destructive test and samples submitted to the solderability test shall not be supplied to this specification.

4.6.3 Group B inspection. Group B inspection shall consist of the tests specified in table VIII, in the order shown, and the sample shall be selected from inspection lots that have passed group A inspection.

TABLE VIII. Group B inspection. 1/

Inspection	Requirement paragraph	Method paragraph	Sampling Procedure
<u>Subgroup 1</u>			
Actual effective electrical travel	3.8	4.7.3	4.6.3.1
Dielectric withstanding voltage	3.10	4.7.5	
Insulation resistance	3.11	4.7.6	
Torque	3.12	4.7.7	
<u>Subgroup 2</u>			
Thermal shock	3.13	4.7.8	4.6.3.2

1/ See table XII.

4.6.3.1 Subgroup 1. A sample of parts shall be randomly selected in accordance with table IX. If one or more defects are found, the lot shall be reworked or screened and defectives removed. After reworking or screening and removal of defectives, a new sample of parts shall be randomly selected in accordance with table IX. If one or more defects are found in the second sample, the lot shall be not supplied to this specification.

TABLE IX. Group B sampling plan.

Lot size	Subgroup 1 and 2 sampling plan
1 to 25	3
26 to 50	5
51 to 90	6
91 to 150	7
151 to 280	10
281 to 500	11
501 to 1,200	15
1,201 to 3,200	18
3,201 to 10,000	22
10,000 and over	29

## MIL-PRF-22097J

4.6.3.2 Subgroup 2. A sample of parts shall be randomly selected with [table IX](#). If one or more defects are found, the lot shall be reworked or screened and defectives removed. After reworking or screening and removal of defectives, a new sample of parts shall be randomly selected in accordance with [table IX](#). If one or more defects are found in the second sample, the lot shall be not supplied to this specification.

4.6.4 Alternate inspection. For the purposes of retention of qualification and conformance inspection ([see 4.5](#) and [4.6](#)), results on identical items covered by [MIL-PRF-39035](#) may be used.

4.6.5 Inspection of preparation for delivery. Sample packages and packs and the inspection of preservation, packaging, packing, and marking for shipment and storage shall be in accordance with [section 5](#).

#### 4.7 Methods of inspection.

4.7.1 Visual and mechanical inspection. Resistors shall be inspected to verify that the materials, design, construction, physical dimensions, marking, and workmanship are in accordance with the applicable requirements ([see 3.1](#), [3.3](#) to [3.3.2](#), [3.4](#) to [3.4.3](#), [3.4.4](#) to [3.4.7](#) inclusive, and [3.28](#) to [3.32](#) inclusive).

4.7.2 DC resistance. Resistors shall be tested in accordance with [method 303](#) of [MIL-STD-202](#) ([see 3.7](#)). The following details shall apply:

- a. Measuring apparatus: The same measuring instrument shall be used for all resistance measurements in any one test, but not necessarily for all the tests.
- b. Measurement energy for electronic test equipment: The measurement energy applied to the unit under test shall not exceed 10 percent of the 25°C rated wattage times 1 second.
- c. Test voltage for bridges: Measurements of resistance shall be made by using the test voltage specified in [table X](#). The test voltage chosen, whether it be the maximum or a lower voltage which would still provide the sensitivity required, shall be applied across the terminals of the resistor. This same voltage shall be used when ever a subsequent resistance measurement s made.

TABLE X. DC resistance test voltage.

Total resistance nominal (in ohms)	Maximum test voltage (in volts)
100	1.0
Over 100 to 1,000 inclusive	3.0
Over 1,000 to 10,000 inclusive	10.0
Over 10,000 to 0.1 megohm, inclusive	30.0
Over 0.1 megohm	100.0

4.7.2.1 Total resistance. The total resistance shall be measured as specified in [4.7.2](#), between the resistance element end terminals (terminals 1 and 3 of [figure 3](#)) with the contact arm against a stop. The positioning of the contact arm and terminal shall be the same for all subsequent measurements of the total resistance on the same specimen ([see 3.7.1](#)).

4.7.2.2 End resistance. The contact arm shall be positioned at the extreme counterclockwise limit of mechanical travel, and the resistance shall be measured as specified in [4.7.2](#) between the contact arm and the corresponding end terminal. The contact arm shall be so positioned at the extreme clockwise limit of clockwise limit of mechanical travel, and the resistance shall be measured as specified in [4.7.2](#) between the contact arm and corresponding end terminal. During this test, precaution shall be taken to insure that rated current of the resistance element is not exceeded. Clockwise and counterclockwise signifies the direction of rotation of the operating shaft when the resistor is viewed from the shaft end ([see 3.7.2](#)).



## MIL-PRF-22097J

4.7.3 Actual effective electrical travel. The actual effective electrical travel shall be measured by placing the resistor in a device and circuit which will indicate both angular position of the operating shaft and voltage output. The actual effective electrical travel will be the number of turns or degrees of the operating shaft in which a change in contact arm position gives a measurable change in voltage output (see 3.8).

4.7.4 Contact resistance variation. Contact resistance variation shall be measured with the measuring circuit shown on figure 3, or its equivalent. The operating shaft shall be rotated in both directions through 90 percent of the actual effective electrical travel for a maximum of six cycles. Only the last 3 cycles shall count in determining whether or not a contact resistance variation is observed at least twice in the same location, exclusive of the roll on or roll off points where the contact arm moves from the termination, on or off, the resistance element. Group A, subgroup I product acceptance may be determined based on one cycle minimum where compliance to the specification is demonstrated. The rate of rotation of the operating shaft shall be such that the wiper completes one cycle in 5 seconds minimum, to 2 minutes maximum (see 3.9).

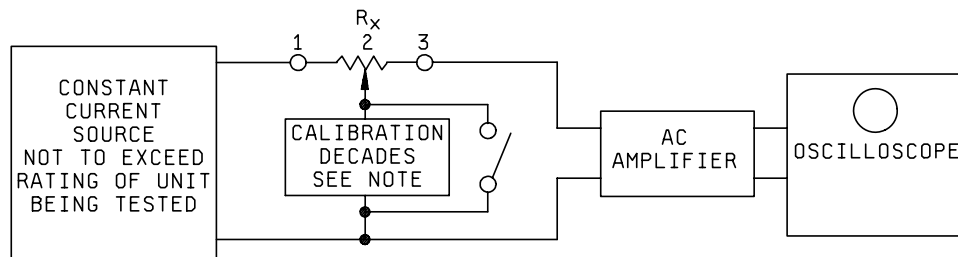

R<sub>x</sub> – Test specimen

Oscilloscope bandwidth: 100 Hz to 50 kHz.

Minimum input impedance: At least 10 times the nominal resistance being tested.

NOTE: At the calibration of the decade, terminals 1 and 2 must be coincident. Calibration decade is to be set for the contact resistance (CRV) level of the specified nominal resistance being tested.

FIGURE 3. Contact resistance variation.

4.7.5 Dielectric withstanding voltage (see 3.10).

4.7.5.1 Atmospheric pressure. Resistors shall be tested in accordance with method 301 of MIL-STD-202. The following details shall apply:

- a. Special preparation: Resistors shall be clamped, or otherwise mounted on metal plates of sufficient size to extend beyond the resistor extremities, tied together and any other external metal parts.
- b. Magnitude of test voltage: As specified (see 3.1).
- c. Nature of potential: From alternating current (ac) supply at commercial line frequency and wave form.
- d. Points of application of test voltage: Between the terminals tied together and all external metal portions of the resistors and metal mounting plate.
- e. Inspection and measurements: During the tests, the leakage current shall be monitored and the resistors inspected for evidence of arcing and breakdown. At the conclusion of the test, resistors shall be examined for evidence of damage.

## MIL-PRF-22097J

4.7.5.2 Barometric pressure. Resistors shall be tested in accordance with [method 105](#) of [MIL-STD-202](#). The following details and exceptions shall apply:

- a. Method of mounting: As specified in 4.7.5.1a.
- b. Test condition C.
- c. Period of time at reduced pressure to application of potential: 1 minute.
- d. Tests during subjection to reduced pressure: Voltage as specified ([see 3.1](#)) from an ac supply at commercial line frequency and waveform shall be applied for 1 minute.
- e. Points of application: As specified in 4.7.5.1d.
- f. Inspections and measurements: As specified in 4.7.5.1e.

4.7.6 Insulation resistance. Resistors shall be tested in accordance with [method 302](#) of [MIL-STD-202](#) ([see 3.11](#)). The following details shall apply:

- a. Test condition: A or B, whichever is more practicable.
- b. Special preparation: As specified in 4.7.5.1a.
- c. Points of application: As specified in 4.7.5.1d.

4.7.7 Torque ([see 3.12](#)).

4.7.7.1 Operating. The maximum operating torque required to move the contact arm on the resistive element shall be determined at approximately 10 percent, 50 percent, and 90 percent of the actual effective electrical travel by the torque wrench or by any other method acceptable to the Government ([see 3.12.1](#)).

4.7.7.2 Clutch. The contact arm shall be adjusted to each extreme limit of mechanical travel, and sufficient torque shall applied to the operating shaft actuator. During idle, a electrical indicating device connected between the contact arm terminal and the adjacent end terminal shall be observed for electrical continuity. After idle, the operating shaft shall be rotated in the opposite direction and the indicating device observed to determine if the contact arm reversed direction ([see 3.12.2](#)).

4.7.7.3 Stop. Resistors shall be mounted by their normal mounting means. The contact arm shall then be rotated to each extreme limit of mechanical rotation, and the specified torque ([see 3.1](#)), applied through the operating shaft to the stop ([see 3.12.3](#)).

4.7.8 Thermal shock. Resistors shall be tested in accordance with [method 107](#) of [MIL-STD-202](#) ([see 3.13](#)). The following details and exceptions shall apply:

- a. Test condition B.
- b. Measurement before cycling: Setting stability and total resistance shall be measured as specified in [4.7.8.1](#) and [4.7.2.1](#), respectively. Continuity of the contact arm shall be verified by connecting a vacuum tube voltmeter or other indicating device, between the contact arm terminal and the counterclockwise end terminal. The applied voltage shall be in accordance with [table XI](#).
- c. Inspection after test: Resistors shall be inspected for evidence of mechanical damage ([see 3.13](#)).

## MIL-PRF-22097J

4.7.8.1 Setting stability. The contact arm shall be set at approximately 40 percent of the actual effective electrical travel. An adequate dc test potential shall be applied between end terminals. The voltage between the end terminals, and the voltage between one end terminal and the contact arm, shall be measured and applied to the following formula:

$$\text{Setting stability} = \frac{E1 \times 100}{E2}$$

Where: E1 = Voltage across one end terminal and the contact arm terminal.  
E2 = Voltage across the end terminals.

The difference between the initial measurement made before the environmental test and the measurement made after the test indicates the setting stability in percent.

4.7.9 Resistance temperature characteristic (not applicable to characteristic A). Resistors shall be tested in accordance with [method 304](#) of [MIL-STD-202](#) ([see 3.14](#)). The following details shall apply:

- a. Test temperatures: As specified in [table XI](#).
- b. Measurement at the end of each period: Total resistance shall be measured as specified in [4.7.2.1](#), at the temperature maintained during the period.

4.7.9.1 Resistance temperature characteristic (applicable to characteristic A only). The resistors shall be maintained at each of the ambient temperatures listed in [table XI](#) ([see 3.14](#)). Resistance measurements shall be made at each temperature, 30 minutes to 45 minutes after resistors have attained that temperature. The temperature adjustment shall be accurate within 1°C. The percent change in resistance, referred to a reference temperature of 25°C, shall be computed by the following formula:

$$\text{Percent change in resistance} = \frac{(R-r) \times 100}{r}$$

Where: R = Resistance at the test temperature.  
r = Resistance at reference temperature.

4.7.10 Moisture resistance. Resistors shall be tested in accordance with [method 106](#) of [MIL-STD-202](#) ([see 3.15](#)). The following details and exceptions shall apply:

- a. Mounting: Clamped, or otherwise mounted with the terminals exposed on a stainless steel panel of sufficient size to extend beyond the resistor extremities, and in such a manner as to allow electrical connections to be made to the terminals.
- b. Initial measurement: Immediately following the initial drying period, total resistance shall be measured as specified in [4.7.2.1](#).
- c. Polarization and loading voltage: The resistors shall be divided in two equal groups; one group shall be subjected to polarization and the other group to load.
  - (1) Polarization: During steps 1 to 6 inclusive, a 100 volt dc potential shall be applied with the positive lead connected to the resistor terminals tied together, and the negative lead connected to the mounting plate.
  - (2) Loading voltage: During the first 2 hours of steps 1 and 4, a dc potential equivalent to 100 percent rated wattage, but not exceeding the maximum rated voltage ([see 3.1](#)), shall be applied to the resistors.

## MIL-PRF-22097J

- d. Test procedures: Moisture resistance cycling requirements shall be 20 cycles.
- e. Final measurements: Upon completion of step 6 of the final cycle, the resistors shall be removed from the chamber and air dried for one-half hour at room ambient conditions. Samples shall not be subjected to force air drying. The total resistance and insulation resistance shall then be measured 30 minutes to 45 minutes after removal from the humidity chambers, as specified in 4.7.2.1 and 4.7.6, respectively. The subsequent 24 hour conditioning period and measurements do not apply.
- f. Inspection after test: Resistors shall be inspected for evidence of mechanical damage.
- g. Steps 7A and 7B; Steps 7A and 7B are not applicable to this specification.

TABLE XI. Resistance temperature characteristic test temperature.

Sequence	Temperature (°C)	
	Characteristic	
	A	C and F
1	25 <u>1/</u>	25 <u>1/</u>
2 <u>2/</u>	-25	-15
3	-55	-55
4	25 <u>1/</u>	25 <u>1/</u>
5 <u>2/</u>	55	65
6	85 <u>3/</u>	
7	125	150

1/ This temperature shall be considered the reference temperature for each of the succeeding temperatures.

2/ Not applicable in conformance inspection.

3/ This temperature applicable to characteristic A only.

NOTE: At the option of the manufacturer, the reverse sequence may be as follows:

1. Room temperature.
2. +150°C ±3°C.
3. Room temperature.
4. -55°C ±3°C.

4.7.11 Shock (specified pulse). Resistors shall be tested in accordance with method 213 of MIL-STD-202 (see 3.16). The following details and exceptions shall apply:

- a. Special mounting means: Resistors shall be mounted by their normal mounting means and within their bodies restrained from movement on an appropriate mounting fixture. The mounting fixture shall be constructed in such a manner as to insure that the mounting supports remain in a static condition with reference to the shock test table. Resistors shall be mounted in relation to the test equipment in such a manner that the stress applied is in the direction which would be considered most detrimental.
- b. Test leads: Test leads used during this test shall be no larger than AWG size 22 stranded wire, so that the influence of the test lead on the resistor shall be held to a minimum. The test lead length shall be no longer than necessary.
- c. Measurement before shock: Total resistance and setting stability shall be measured as specified in 4.7.2.1 and 4.7.8.1, respectively.
- d. Test condition I.

## MIL-PRF-22097J

- e. Measurements during shock: Each resistor shall be monitored to determined electrical discontinuity of the resistance element, between the contact arm and element, by a method that shall at least be sensitive enough to monitor or register, automatically, any electrical discontinuity of 0.1 ms or greater duration.
- f. Measurements after shock: Setting stability and total resistance shall be measured as specified 4.7.8.1 and 4.7.2.1, respectively.
- g. Inspection after shock: Resistors shall be inspected for evidence of mechanical damage.

4.7.12 Vibration, high frequency. Resistors shall be tested in accordance with method 204 of MIL-STD-202 (see 3.17). The following details and exceptions shall apply:

- a. Mounting: As specified in 4.7.11a.
- b. Test leads: As specified in 4.7.11b.
- c. Measurements before vibration: As specified in 4.7.11c.
- d. Test condition D.
- e. Measurement during vibration: As specified in 4.7.11e.
- f. Measurements after vibration: As specified in 4.7.11f, and torque as specified in 4.7.7.1.
- g. Inspection after vibration: Resistors shall be inspected for evidence of mechanical damage.

4.7.13 Salt spray (corrosion). Resistors shall be tested in accordance with method 101 of MIL-STD-202 (see 3.18). The following details shall apply:

- a. Special mounting: As specified in 4.7.10a.
- b. Test condition A.
- c. Inspection after exposure: Resistors shall be inspected for corrosion.

4.7.14 Resistance to soldering heat (applicable to terminal types P, S, W, X, and Y only). Total resistance shall be measured as specified in 4.7.2.1. All resistors terminals shall be immersed in a pot of molten solder at a temperature  $350^{\circ}\text{C} \pm 10^{\circ}\text{C}$ , for a period of 3.0 seconds  $\pm 5$  second, to a point .125 inch (3.18 mm) from the entry of the terminal into the resistor body. After a minimum of 3 hours have elapsed, total resistance shall be measured as specified in 4.7.2.1. Resistors shall then be inspected for evidence of mechanical damage (see 3.19).

4.7.15 Life. Resistors shall be tested in accordance with method 108 of MIL-STD-202 (see 3.20). The following details and exceptions shall apply:

- a. Method of mounting: Resistors shall be mounted by their normal mounting means, on a .625 inch (1.588 mm) thick, glass base, epoxy laminate. The resistors shall be so arranged that the temperature of any one resistor shall not appreciably influence the temperature of any other resistor. There shall be no circulation of air over the resistors other than that caused by the heat of the resistors
- b. Test temperatures and tolerances:  $70^{\circ}\text{C} \pm 5^{\circ}\text{C}$  for characteristic A, and  $85^{\circ}\text{C} \pm 5^{\circ}\text{C}$  for characteristic C and characteristic F.
- c. Initial measurements: Measurements may be made inside or outside the chamber. Total resistance and setting stability shall be measured as specified in 4.7.2.1 and 4.7.8.1, respectively.
- d. After resistors have been stabilized at their respective temperatures for at least 8 hours, the resistance between the end terminals, with the contact arm in the position for setting stability, shall be measured.

## MIL-PRF-22097J

- e. Operating conditions: Rated dc or ac continuous working voltage at commercial line frequency and waveform (see 3.1), shall be applied intermittently to the end terminal of the resistors, 1.5 hours "on", a half hour off, for a total of 1,000 hours, at the test temperature. Each resistor shall dissipate rated wattage, but shall not exceed maximum voltage. Adequate precaution shall be taken to maintain constant voltage on the resistor.
- f. Test condition D.
- g. Measurement during test: While resistors are still in the oven, resistance shall be measured between the end terminals at the end of the half hour "off" periods after 50 hours  $\pm 4$  hours, 100 hours  $\pm 8$  hours, 250 hours  $\pm 12$  hours, 500 hours  $\pm 12$  hours, 750 hours  $\pm 12$  hours, and 1,000 hours  $\pm 12$  hours have elapsed and compared to the similar readings taken 4.7.15d.
- h. Measurement outside of chamber: When measurements are made outside the chamber, resistor shall be outside of the chamber for a minimum of 45 minutes and stabilized before measurement.
- i. Measurement after test: After resistors have been removed from the oven and returned to room temperature, setting stability and total resistance shall be measured as specified in 4.7.8.1 and 4.7.2.1, respectively, and compared to the similar readings taken in 4.7.15c. Dielectric withstanding voltage (at atmospheric pressure), and torque shall be measured as specified in 4.7.5.1 and 4.7.7.1, respectively.
- j. Inspection after test: Resistors shall be inspected for evidence of mechanical damage.

4.7.16 Low temperature operation (see 3.21).

4.7.16.1 Mounting. Resistors shall be mounted in such a manner as to allow electrical connections to be made to the terminals.

4.7.16.2 Procedure. Total resistance shall be measured as specified in 4.7.2.1 and 4.7.8.1, respectively. The resistor shall be placed in a chamber at room temperature. The temperature shall be gradually decreased to  $-55^{\circ}\text{C}$   $+0^{\circ}\text{C}$ ,  $-5^{\circ}\text{C}$  within a period "off" not less than one and one half hours. After 1 hour of stabilization at this temperature, setting stability shall be measured as specified 4.7.8.1. Full rated continuous working voltage (see 3.1 and 3.6) shall be applied for 45 minutes. The resistors may be loaded individually or in parallel. Fifteen minutes  $+5$  minutes,  $-0$  minutes after removal of voltage, setting stability shall be measured as specified in 4.7.8.1. The temperature in the chamber shall be gradually increased to room temperature within a period of not more than 8 hours. The resistors shall be removed from the chamber, and maintained at a temperature of  $25^{\circ}\text{C} \pm 5^{\circ}\text{C}$  for a period of approximately 24 hours. Total resistance shall be measured as specified in 4.7.2.1. Resistors shall be examined for evidence of mechanical damage.

4.7.17 High temperature exposure (see 3.22).

4.7.17.1 Mounting. Resistors shall be examined in such a manner as to allow electrical connections to be made to the terminals.

4.7.17.2 Procedure. Total resistance and setting stability shall then be measured as specified in 4.7.2.1 and 4.7.8.1, respectively. The resistors shall then be exposed to an ambient temperature of  $125^{\circ}\text{C} +5^{\circ}\text{C}$ ,  $-0^{\circ}\text{C}$  for characteristic A, and  $150^{\circ}\text{C} +5^{\circ}\text{C}$ ,  $-0^{\circ}\text{C}$  for characteristic C and characteristic F for a period of 250 hours  $\pm 8$  hours. Not less than 2 hours after the end of the exposure period, setting stability and total resistance shall be measured in 4.7.8.1 and 4.7.2.1, respectively. Torque shall be measured as specified in 4.7.7.1, except that it shall be determined during the movement of the contact arm from the position for setting stability to the position for total resistance. Dielectric withstanding voltage (at atmospheric pressure), and insulation resistance shall be measured as specified in 4.7.5.1 and 4.7.6, respectively. Resistors shall then be examined for evidence of mechanical damage.

## MIL-PRF-22097J

4.7.18 Rotational life (see 3.23).

4.7.18.1 Mounting. Resistors shall be mounted by their normal mounting means on a .625 inch (15.88 mm) thick, glass base, epoxy laminate. The resistors shall be ganged in pairs, and each pair shall be connected in series, as shown on figure 4, so that a nominally constant current flows through the resistors, irrespective of the contact arm position during the tuning of the operating shaft.

4.7.18.2 Procedure. Total resistance shall be measured as specified in 4.7.2.1. A dc potential, equivalent to that required to dissipate rated wattage across the entire resistive element of resistors having the same total resistance as those under test, but not exceeding the maximum rated voltage, shall then be applied as shown on figure 4. The operating shaft shall be continuously cycled through not less than 90 percent of the actual effective electrical travel, at the rated 1 cycle for 2 minutes  $\pm 0.5$  minutes, for a total of 200 cycles. A cycle shall consist of travel through 90 percent of actual effective electrical travel and return to the starting point. After rotation, total resistance shall be measured as specified in 4.7.2.1. Resistors shall then be inspected for evidence of mechanical damage.

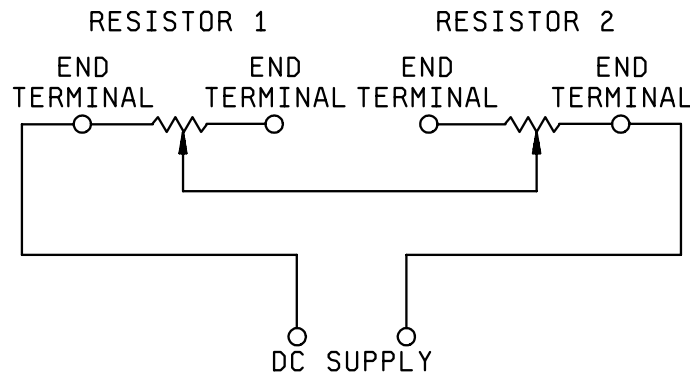

FIGURE 4. Rotational life test circuit.

4.7.19 Terminal strength (see 3.24).

4.7.19.1 Pull (applicable to all terminal types). Resistors shall be tested in accordance with method 211 of MIL-STD-202. The following details and exceptions shall apply:

- a. Test condition A: Applied force : 2 pounds. Resistors clamped by the resistor body, force applied to each lead individually.
- b. Measurement after test: Resistors shall be inspected for evidence of mechanical damage, and tested for electrical continuity.

4.7.19.2 Push (applicable to all terminals except type L). Resistors shall be tested in accordance with method 211 of MIL-STD-202. The following details and exceptions shall apply:

- a. Test condition A: except force shall be applied in the direction toward the resistor body. Applied force: 2 pounds. Resistor clamped by the resistor body, force applied to each terminal individually.
- b. Measurement after test: Resistors shall be inspected for evidence of mechanical damage, and tested for electrical continuity.

## MIL-PRF-22097J

4.7.19.3 Bend (applicable to terminal types P, W, X, and Y only). Resistors shall be firmly clamped and each terminal shall be bent through a 90 degree point .125 inch (3.18 mm) from the body of the resistor, with the radius of the curvature at the bend approximately .03125 inch (0.7938 mm). The pin shall be returned to the original position, bent 90 degree in the opposite direction, and again return to the original position. At the conclusion of the test, the resistors shall be examined for evidence of mechanical damage and tested for electrical continuity.

4.7.20 Solderability (applicable to terminal types P, W, X, and Y only). Resistors shall be tested in accordance with [method 208](#) of [MIL-STD-202](#). The three pin terminal of each resistor shall be tested ([see 3.25](#)).

4.7.21 Immersion (not applicable to L terminations). The surface shall be cleaned of any foreign matter immediately before immersion ([see 3.26](#)).

- a. Precondition: Precondition resistors in an oven at  $125^{\circ}\text{C} \pm 5^{\circ}\text{C}$  for 13 minutes  $\pm 2$  minutes, or use a fluorocarbon bath maintained at  $125^{\circ}\text{C} \pm 5^{\circ}\text{C}$  for a period of 1.5 minutes  $\pm .5$  minute. Upon completion of precondition, allow resistors to stabilize to room temperature for approximately 13 minutes  $\pm 2$  minutes.
- b. Immersion: Immerse resistors (not to exceed 30 samples) into a bath of fluorocarbon bath held at  $85^{\circ}\text{C} + 5^{\circ}\text{C}$ ,  $-0^{\circ}\text{C}$  for a period of 60 seconds  $\pm 5$  seconds. The resistor shall be completely submerged in the bath, with no part at a depth of less than 1 inch. Resistors shall be shaken for a maximum of 5 seconds and shall remain in the bath for a period of 1 minute  $\pm 5$  seconds. Visually examine resistors for inadequate seals, as evidenced by a continuous stream of bubbles emanating from any concentrated point on the resistor.
- c. Dye penetrant verification: A five piece sample of the product exhibiting inconclusive evidence of compliance to immersion requirements ([see 3.26](#)), shall be preconditioned in an oven, stabilized at  $125^{\circ}\text{C} \pm 5^{\circ}\text{C}$  for 13 minutes  $\pm 2$  minutes, or preconditioned in a fluorocarbon bath maintained at  $125^{\circ}\text{C} \pm 5^{\circ}\text{C}$  for 1 minute  $\pm 5$  seconds and immediately upon removal (within 5 seconds), shall be submerged in a dye penetrant solution for 30 seconds minimum. The dye penetrant solution shall consist of 0.1 grams per liter, or equivalent, of a soluble stain dye such as crystal violet dissolved in deionized water maintained at room temperature until external surfaces are dry. The samples shall then be carefully opened and examined under 10X to 30X for evidence of dye penetration into the sealed cavity. Evidence of such penetration verifies loss of immersion seal, and lack of such evidence verifies compliance to the requirements.

4.7.22 Fungus. Resistors shall be tested in accordance with [method 508](#) of [MIL-STD-810](#). Resistors shall be inspected for evidence of mechanical damage ([see 3.27](#)).

## 5. PACKAGING

5.1 Packaging. For acquisition purposes, the packaging requirements shall be as specified in the contract or order ([see 6.2](#)). When packaging of materiel is to be performed by DoD or in-house contractor personnel, these personnel need to contact the responsible packaging activity to ascertain packaging requirements. Packaging requirements are maintained by the Inventory Control Point's packaging activity within the Military Service or Defense Agency, or within the military services system commands. Packaging data retrieval is available from the managing Military Department's or Defense Agency's automated packaging files, CD-ROM products, or by contacting the responsible packaging activity.

## 6. NOTES

(This section contains information of a general or explanatory nature that may be helpful, but is not mandatory.)

6.1 Intended use. Resistors covered by this specification are intended for use in electronic equipment, and are used for matching, balancing, adjusting circuit variables in computers, telemetering equipment, and other critical applications. Resistors covered by this specification are unique due to the fact that these devices must be able to operate satisfactorily in military systems under the following demanding conditions: 20 Gs of high frequency vibration, 100 Gs of shock (specified pulse), undergo moisture resistance, setability, and salt corrosion test. In addition these military requirements are verified under a qualification system. Commercial components are not designed to withstand these military environmental conditions.



## MIL-PRF-22097J

6.2 Acquisition requirements. Acquisition documents must specify the following:

- a. Title, number, and date of this date of this specification, the applicable associated specification, and the complete PIN.
- b. If not otherwise specified ([see 2.1](#)), the versions of the individual documents referenced will be those in effect on the date of release of the solicitation.
- c. Packaging requirements ([see 5.1](#)).
- d. Allowable substitution ([see 3.29](#)).

6.3 Qualification. With respect to products requiring qualification, awards will be made only for products which are, at the time of award of contract, qualified for inclusion in the [Qualified Products List](#) whether or not such products have actually been so listed by that date. The attention of the contractors is called to these requirements, and manufacturers are urged to arrange to have the products that they propose to offer to the Federal Government tested for qualification in order that they may be eligible to be awarded contracts or orders for the products covered by this specification. Information pertaining to qualification of products may be obtained from Defense Supply Center, Columbus, ATTN: DSCC-VQP, 3990 East Broad Street, Columbus, Ohio 43218-3990.

6.4 Sequence for inspection, measurements, and tests. The sequence for inspections, measurements, and tests should be in accordance with [table XII](#).

6.5 High resistance and voltages. Where voltages higher than 250 V rms are present between the resistor circuit and grounded surfaces on which the resistor is mounted, or where the dc resistance is so high that the insulation resistance to ground is an important factor, secondary insulation to withstand the conditions should be provided between the resistor and mounting or between the mounting and ground.

6.6 Mounting resistors. Resistors should not be mounted by their lugs or flexible wire leads. Mounting hardware should be used. Printed circuits types are frequently terminal mounted, although brackets may be necessary for a high shock and vibration environment.

6.7 Resistance temperature characteristic. Consideration should be given to temperature rise and ambient temperature of resistors under operation, in order to allow for the change in resistance due to resistance temperature characteristic. Resistance tolerance may be easily be exceeded unless care is exercised.

## MIL-PRF-22097J

TABLE XII. Sequence for inspections, measurements, and tests. 1/

Inspection	Total resistance	Contact resistance variation	Dielectric withstanding voltage (at atmospheric pressure)	Insulation resistance	Torque	Resistance measured between terminals 1 and 3	Setting stability
<u>Group I</u> Visual and mechanical inspection Actual effective electrical travel End resistance Thermal shock	A  B, A	 A	Atmospheric and barometric	 A	 A		 B, A
<u>Group II</u> Resistance temperature characteristic Moisture resistance	 B, A	 A		 A			
<u>Group III</u> Shock (specified pulse) Vibration, high frequency Salt spray (corrosion)	B, A B, A	 A			 A		 B, A B, A
<u>Group IV</u> Resistance to soldering heat (terminal types P, S, W, X, Y) Life	B, A B, A	 A	 A		 A	 B, D, A	 B, A
<u>Group V</u> Low temperature operation High temperature exposure	B, A B, A	 A	 A	 A	 A		 B, A B, A
<u>Group VI</u> Rotational life Terminal strength	 B, A	 A					
<u>Group VII</u> Solderability (terminal types P, W, X, Y) Immersion (terminal types P, W, X, Y)							

1/ B: Before test.

D: During test.

A: After test.

6.8 Supersession of characteristic. Characteristic B has been deleted. Resistors having characteristic B is replaced by resistors having characteristic C.

6.9 Reduction of power rating. When only a portion of the resistance element is engaged, the wattage rating is reduced in approximately the same proportion as the resistance.

6.10 Stacking of resistors. When stacking of resistors, care should be taken to compensate for the added rise in temperature by derating the wattage rating accordingly.

6.11 Retinning leads. If retinning (hot solder dip) of the leads is required see appendix A.

6.12 Subject term (key word) listing.

Ohmic  
Potentiometer  
Resistance  
Trimmer  
Multiturn  
Single turn

## MIL-PRF-22097J

6.13 Tin whisker growth. The use of alloys with tin content greater than 97 percent, by mass, may exhibit tin whisker growth problems after manufacture. Tin whiskers may occur anytime from a day to years after manufacture and can develop under typical operating conditions, on products that use such materials. Conformal coatings applied over top of a whisker-prone surface will not prevent the formation of tin whiskers. Alloys of 3 percent lead, by mass, have shown to inhibit the growth of tin whiskers. For additional information on this matter, refer to [ASTM-B545](#) (Standard Specification for Electrodeposited Coatings of Tin).

6.14 Environmentally preferable material. Environmentally preferable materials should be used to the maximum extent possible to meet the requirements of this specification. Table XIII lists the Environmental Protection Agency (EPA) top seventeen hazardous materials targeted for major usage reduction. Use of these materials should be minimized or eliminated unless needed to meet the requirements specified herein ([see section 3](#)).

TABLE XIII. EPA top seventeen hazardous materials.

Benzene	Dichloromethane	Tetrachloroethylene
Cadmium and Compounds	Lead and Compounds	Toluene
Carbon Tetrachloride	Mercury and Compounds	1,1,1 - Trichloroethane
Chloroform	Methyl Ethyl Ketone	Trichloroethylene
Chromium and Compounds	Methyl Isobutyl Ketone	Xylenes
Cyanide and Compounds	Nickel and Compounds	

6.15 Changes from previous issue. The margins of this specification are marked with vertical lines to indicate where changes from the previous issue were made. This was done as a convenience only and the Government assumes no liability whatsoever for any inaccuracies in these notations. Bidders and contractors are cautioned to evaluate the requirements of this document based on the entire content irrespective of the marginal notations and relationship to the last previous issue.

## MIL-PRF-22097J

## APPENDIX A

## PROCEDURE FOR QUALIFICATION INSPECTION

## A.1. SCOPE

A.1.1 Scope. This appendix details the procedure for submission of samples for qualification inspection of resistors covered by this specification. The procedure for extending qualification of the required sample to other resistors covered by this specification is also outlined herein. This is a mandatory part of the specification. The information contained herein is intended for compliance.

## A.2. APPLICABLE DOCUMENTS

A.2.1 General. The documents listed in this section are specified in [sections 3](#) and [4](#) of this specification. This section does not include documents cited in other sections of this specification or recommended for additional information or as examples. While every effort has been made to ensure the completeness of this list, document users are cautioned that they must meet all specified requirements documents cited in [sections 3](#) and [4](#) of this specification, whether or not they are listed.

A.2.2 Government documents.

A.2.2.1 Specifications, standards, and handbooks. The following specifications, standards, and handbooks form a part of this document to the extent specified herein. Unless otherwise specified, the issues of these documents are those cited in the solicitation ([see 6.2](#)).

## DEPARTMENT OF DEFENSE STANDARDS

[MIL-STD-1276](#) - Leads for Electronic Component Parts.

(Copies of these documents are available online at <http://assist.daps.dla.mil/quicksearch/> or <http://assist.daps.dla.mil> or from the Standardization Document Order Desk, 700 Robbins Avenue, Building 4D, Philadelphia, PA 19111-5094).

A.2.3 Order of precedence. In event of a conflict between the text of this document and the references cited herein (except for related associated specifications, specification sheets, or MS sheets), the text of this document takes precedence. Nothing in this document, however, supersedes applicable laws and regulations unless a specific exemption has been obtained.

## A.3. SUBMISSION

A.3.1 Sample. A sample consisting of 33 enclosed sample units and 2 unenclosed sample units each with the same terminal type, and of highest and lowest resistance values in each style and characteristic for which qualification is sought shall be submitted.

## A.4. EXTENT OF QUALIFICATION

A.4.1 Extension of qualification. The resistance range included in the qualification of any one resistor style will be between the highest and lowest resistance values inspected. Qualification of characteristic F is the basis for qualification of characteristic C. Characteristic C or characteristic F qualification may also be extended to characteristic A provided test data shows that the 2 percent contact resistance variation requirement of characteristic A has been met. Qualification of one terminal type may be extended to other terminal types provided the internal construction is the same and additional testing is performed in accordance with [table A-I](#).

## MIL-PRF-22097J

## APPENDIX A

TABLE A-I. Additional testing required to extend qualification to other styles.

Terminal types qualified	Terminal type for which qualification is sought	Number of additional sample units		Tests from table V to be performed on additional sample units
P, S, W, or X	L	6	3 highest resistance value	Test group I moisture resistance and terminal strength
			3 lowest resistance value	
P	S, W, or X	6	3 highest resistance value	Test group I and III and terminal strength <u>1/</u>
			3 lowest resistance value	
P	Y	6 any resistance value		Visual and mechanical inspection
S, L, or X	P	6 any resistance value		Visual and mechanical inspection
L	P, W, or X	9	6 highest resistance value	Test groups I, III, VII <u>2/</u> and terminal strength <u>1/</u>
			3 lowest resistance value	
W or X	P	6 any resistance value		Visual and mechanical inspection
X	W	6 any resistance value		Visual and mechanical inspection
W	X	6 any resistance value		Visual and mechanical inspection

1/ Where terminal strength is required the six sample units from the previous test, or six additional sample units may be used at the option of the supplier.

2/ All nine sample units shall be submitted to test group I, then subdivided with six sample units submitted test group III and the remaining three sample units submitted to test group VII.

## A.5. SOLDER DIP (RETNING) LEADS

A.5.1 Solder dip (retinning) leads. The manufacturer may solder dip/retin the leads of product supplied to this specification provided the solder dip process has been approved by the qualifying activity.

A.5.2 Qualifying activity approval. Approval of the solder dip process will be based on one of the following options:

- a. When the original lead finish qualified was hot solder dip lead finish 52 of [MIL-STD-1276](#). (NOTE: The 200 microinch maximum thickness is not applicable). The manufacturer shall use the same solder dip process for retinning as is used in the original manufacture of the product.
- b. When the lead originally qualified was not hot solder dip finish 52 of [MIL-STD-1276](#) as prescribed in A.5.2a, approval for the process to be used for solder dip shall be based on the following test procedure:
  - (1) Thirty samples of any resistance value for each style and lead finish are subjected to the manufacturer's solder dip process. Following the solder dip process, the resistors are subjected to the dc resistance test (and other group A electricals). No defects are allowed.
  - (2) Ten of the 30 samples are then subjected to the solderability test. No defects are allowed.
  - (3) The remaining 20 samples are subjected to the resistance to soldering heat test followed by the moisture resistance test. No defects are allowed.

MIL-PRF-22097J

APPENDIX A

A.5.3 Solder dip retinning options. The manufacture may solder dip/retin as follows:

- a. Following the solder dip/retinning process, total resistance and immersion tests shall be repeated on the lot. The group A, subgroup 4, lot rejection criteria shall be used. Following these tests, the manufacturer shall submit the lot to the group A solderability test as specified in [4.7.20](#).
- b. As a corrective action, if the lot fails the group A solderability test, the lot may be retinned no more than two times. The lot after retinning shall be 100 percent screened for group A electrical requirements (dc resistance) and parts failing (lot not exceeding PDA for group A, subgroup 1, see [4.6.2.1.1](#)) these screens shall not be supplied to this specification, if electrical failures are detected after the second retinning operation exceeding 1 percent of the lot, the lot shall not be supplied to this specification.
- c. After group A inspection has been completed. Following the solder dip/retinning process, the electrical measurements required in group A, subgroup 1, 100 percent screening tests shall be repeated on 100 percent of the lot. The PDA for the electrical measurements shall be as for the subgroup 1 tests. Following these tests, the manufacturer shall submit the lot to the group A solderability test as specified in [4.7.20](#).

Custodians:

Army – CR  
Navy – EC  
Air Force – 11  
DLA - CC

Preparing activity:

DLA – CC

(Project 5905-2007-041)

Review activities:

Army – AR, AT, AV, CR4, MI  
Navy – AS, MC, OS  
Air Force – 19, 99

NOTE: The activities listed above were interested in this document as of the date of the this document. Since organizations and responsibilities can change, you should verify the currency of the information above using the Assist Online database at <http://assist.daps.dla.mil>.