

**INCH-POUND**MIL-PRF-94E  
10 September 1992  
SUPERSEDING  
MIL-R-94D  
16 January 1974

NOTE: The document identifier and heading has been changed on this page to reflect that this is a performance specification. There are no other changes to this document. The document identifier on subsequent pages has not been changed, but will be changed the next time this document is revised.

## PERFORMANCE SPECIFICATION

RESISTORS, VARIABLE, COMPOSITION  
GENERAL SPECIFICATION FOR

This specification is approved for use by all Departments and Agencies of the Department of Defense.

## 1. SCOPE

1.1 Scope. This specification covers the variable resistors having a composition resistance element shaped in a arc, and a contact bearing uniformly thereon, so that a change in resistance is produced between the terminal of the contact and the terminal of either end of the resistance element when the operating shaft is turned. These resistors are capable of full load operation (where maximum resistance is engaged) at a maximum ambient temperature of 70°C, and are suitable for continuous operation when properly derated, at a maximum temperature of 120°C (see 6.8).

1.2 Classification.

1.2 Part or Identifying Number (PIN). The PIN shall be in the following form and as specified (see 3.1 and 6.2):

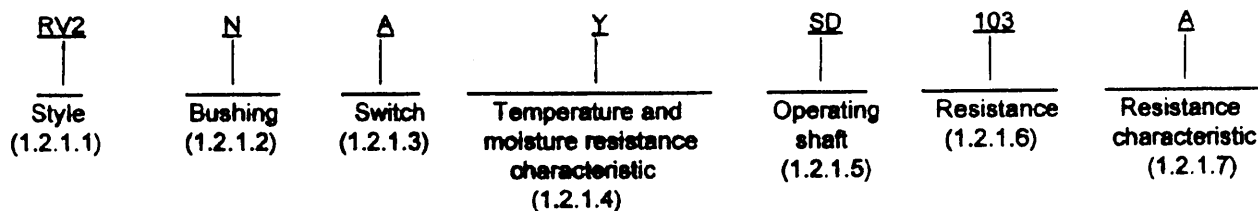

1.2.1.1 Style. The style is identified by the two letter symbol "RV" followed by a one-digit number. The letters identify composition, variable resistors and the number identifies the size and power rating.

1.2.1.2 Bushing. The type of bushing is identified by a single letter in accordance with table I.

TABLE I. Bushing.

| Symbol | Bushing                           |
|--------|-----------------------------------|
| N      | Standard                          |
| L      | Locking                           |
| S      | Shaft and panel-sealed (standard) |
| T      | Shaft and panel sealed (locking)  |

Beneficial comments (recommendations, additions, deletions) and any pertinent data which may be of use in improving this document should be addressed to: DESC-ELDM, 1507 Wilmington Pike, Dayton, OH 45444-5785 by using the self-addressed Standardization Document Improvement Proposal (DD Form 1426) appearing at the end of this document or by letter.

## MIL-R-94E

1.2.1.3 Switch. The type of switch or absence of a switch is identified by a single letter in accordance with table II.

TABLE II. Switch.

| Symbol | Bushing  |
|--------|--|
| A      | No Switch  |
| B      | Single pole, single throw switch which is actuated to the "on" position at the start of clockwise rotation |

1/ For replacement purposes only. Not to be used for new design.

1.2.1.4 Temperature and moisture-resistance characteristic. The temperature and moisture resistance characteristic is identified by a single letter in accordance with table III.

TABLE III. Temperature and Moisture resistance characteristic.

| Symbol | Maximum ambient operating temperature | Maximum ambient temperature at rated wattage | Allowable change in total resistance due to moisture resistance (see 4.6.10) | Insulation resistance (see 4.6.4) |
|--------|---------------------------------------|--|--|-----------------------------------|
|        |                                       |  | Maximum  |                                   |
| Y      | °C<br>120                             | °C<br>70                                     | Percent<br>10  | Megohms<br>100                    |

1.2.1.5 Operating shaft. The operating shaft styles and lengths are identified by a two digit symbol. The first letter indicates operating shaft in accordance with table IV, and the second letter indicates operating shaft length, as specified (see 3.1).

TABLE IV. Style of operating shaft.

| Symbol | Shaft   |
|--------|---------|
| F      | Slotted |
| S      | Flatted |

1.2.1.6 Resistance. The nominal total resistance value expressed in ohms is identified by a three digit number. The first two digits represent significant figures and the last specified the number of zeros to follow.

1.2.1.7 Resistance characteristic. The resistance characteristic is identified by a single letter in accordance with table V.

## MIL-R-94E

TABLE V. Resistance characteristic.

| Symbol | Resistance taper<br>(see figures 3 and 4) | Resistance<br>tolerance |
|--------|---|-------------------------|
| A      | A   | Percent ( $\pm$ )<br>10 |
| B      | A   | 20                      |
| C      | C   | 10                      |
| D      | C   | 20                      |
| E      | F   | 10                      |
| F      | F   | 20                      |

1.2.1.8 Example of PIN. The PIN RV2NAYS0103A signifies:

- RV2 - A composition, variable resistor of the dimensions and power rating specified (see 3.1).
- N - Standard bushing.
- A - No switch.
- Y - Temperature and moisture resistance characteristic as specified in table III.
- SD - Slotted shaft .875 inch long.
- 103 - Nominal total resistance value of 10,000 ohms.
- A - Linear taper with resistance tolerance of  $\pm 10$  percent.

## 2. APPLICABLE DOCUMENTS

2.1 Government documents.

2.1.1 Specifications, standards, and handbooks. The following specifications, standards, and handbooks form a part of this document to the extent specified herein. Unless otherwise specified, the issues of these documents are those listed in the issue of the Department of Defense Index of Specifications and Standards (DODISS) and supplement thereto, cited in the solicitation (see 6.2).

## SPECIFICATION

## FEDERAL

- QQ-B-654 - Brazing, Alloy, Silver.
- QQ-S-571 - Solder, Tin alloy; Lead-Tin alloy; and Lead alloy.

## MILITARY

- MIL-R-39032 - Resistors, Packaging of.

(See supplement 1 for list of associated detail specifications.)

## STANDARDS

## FEDERAL

- FED-STD-H2B - Screw Thread Standards for Federal Services.

## MILITARY

- MIL-STD-202 - Test Methods for Electronic and Electrical Component Parts.
- MIL-STD-810 - Environmental Test Methods and Engineering Guidelines.
- MIL-STD-45662 - Calibration Systems Requirements.

(Unless otherwise indicated, copies of the federal and military specifications, standards, and handbooks are available from the Standardization Documents Order Desk, Building 40, 700 Robins Avenue, Philadelphia, PA 19111-5094.)

## MIL-R-94E

2.3 Order of precedence. In the event of a conflict between the text of this document and the references cited herein (except for related associated detail specifications, specification sheets, or MS standards), the text of this document shall take precedence. Nothing in this document, however, supersedes applicable laws and regulations unless a specific exemption has been obtained.

## 3. REQUIREMENTS

3.1 Associated detail specifications. The individual part requirements shall be as specified herein and in accordance with the applicable associated detail specifications. In the event of a conflict between requirements of this specification and the detail specifications, the latter shall govern (see 6.2).

3.2 Qualification. Resistors furnished under this specification shall be products which are authorized by the qualifying activity for listing on the applicable qualified products list at the time of award of contract (see 4.4 and 6.3).

3.3 Material. The material shall be as specified herein. However, when a definite material is not specified, a material shall be used which will enable the resistors to meet the performance requirements of this specification. Acceptance or approval of any constituent material shall not be construed as a guaranty of the acceptance of the finished product.

3.4 Design and construction. Resistors shall be of the design, construction, and physical dimensions specified (see 3.1).

3.4.1 Operating shaft. All operating shafts shall be of the metal construction.

3.4.1.1 Size. The diameter and length of the operating shaft shall be as specified (see 3.1).

3.4.1.2 Style of operating shaft.

3.4.1.2.1 Slotted operating shaft (see 3.1). In no case shall the slots of slotted shafts be deep enough to interfere with shaft retainers or bearing surfaces. The slot shall be so positioned that the longitudinal centerline of the slot is within  $\pm 10^\circ$  of the longitudinal centerline of the contact area.

3.4.1.2.2 Flattened operating shaft (see 3.1). When flattened operating shaft are specified, the flattened portion shall be as specified in 3.1 and shall be as shown on figure 1. For shafts of 0 length, the flattened surface shall start  $.031 \pm .005$  inch (0.13 mm) from the retaining ring and extend to the free end of the operating shaft.

3.4.2 Rotation. The total mechanical rotation and the electrical rotation shall be defined on figure 2. The electrical rotation of resistors with switches shall be equal to the rotation from the stop at the end opposite the switch to the point where members engage to actuate the switch to the "off" position.

3.4.2.1 Clockwise taper. A clockwise taper is a resistance taper in which the resistance varies approximately as shown on figure 3, increasing as the rotation angle increases in a clockwise direction as viewed from the operating shaft, and measured between the terminals indicated as 1 and 2 on figure 2.

3.4.2.2 Counterclockwise taper. A counterclockwise taper is a resistance taper in which the resistance varies approximately as shown on figure 4 increasing as the rotation angle increases in a counterclockwise direction as viewed from the operating shaft, and measured between terminals indicated as 3 and 2 on figure 2.

3.4.3 Contact-arm assembly. Contact pressure on the resistance element shall be maintained uniformly by positive pressure and shall be such as to permit smooth electrical and mechanical control of the resistor over the entire range of electrical rotation (see figure 2). The rotating contact shall have continuous electrical contact with its terminal throughout the entire electrical rotation and shall be insulated from the rotating operating shaft and the resistor housing. The entire contact-arm assembly shall be sufficiently sturdy to preclude the necessity of adjustment during the life of the resistor.

3.4.3.1 Stops. Stops employed to limit the mechanical rotation of the contact-arm assembly may be part of, but shall not complete any electrical circuit.

MIL-R-94E

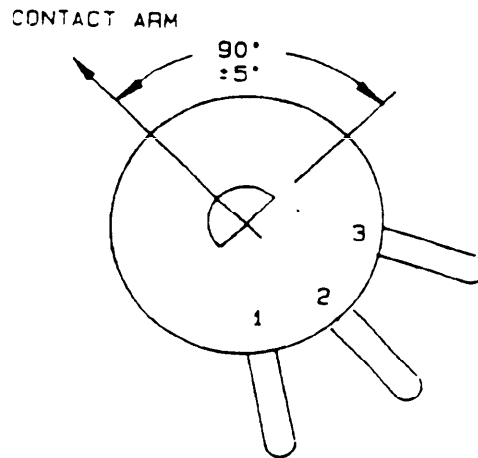

FIGURE 1. Position of flattened surface of flattened operation shaft.

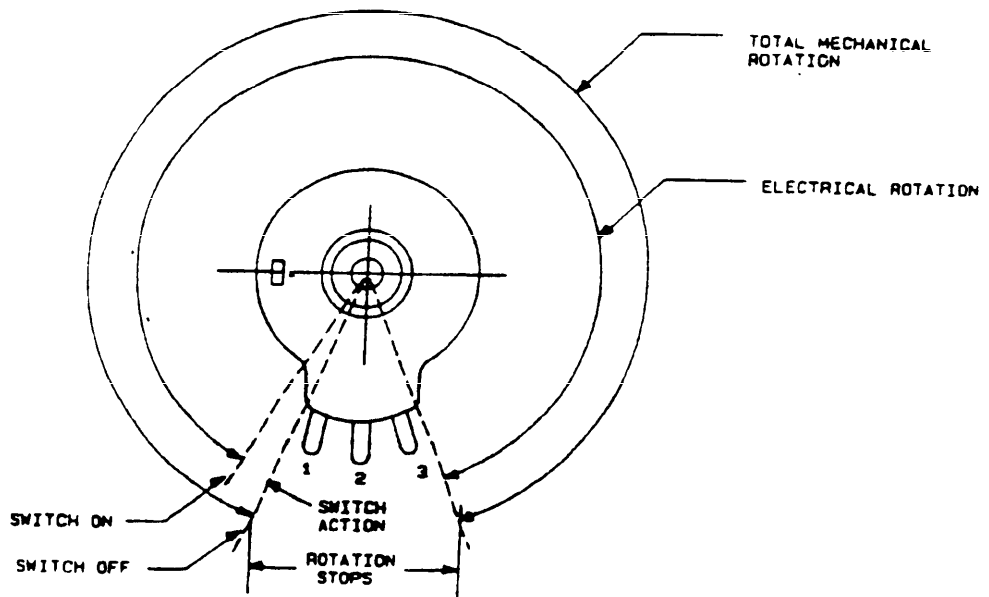

FIGURE 2. Definition of rotation (shaft end view).

MIL-R-94E

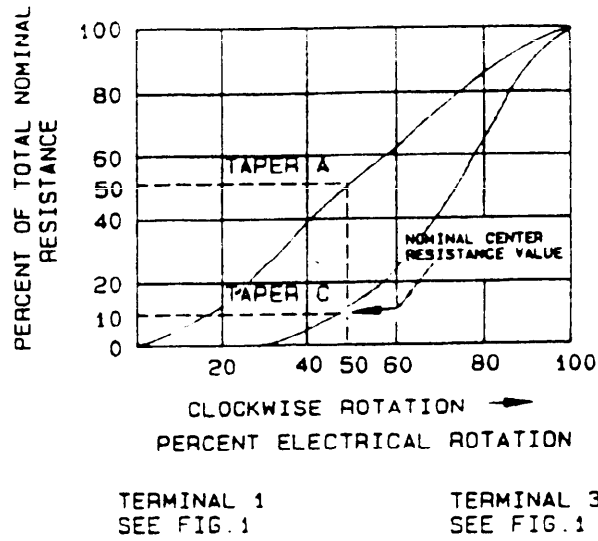

FIGURE 3. Clockwise taper.

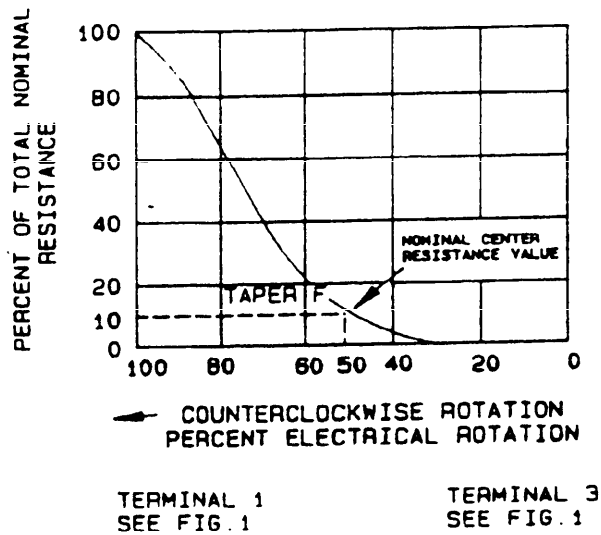

FIGURE 4. Counterclockwise taper.

## MIL-R-94E

**3.4.4 Terminals.** Resistors and attached switches shall be supplied with external terminal lugs or terminal loops of such size and styles as to permit accommodating and soldering of three .032 inch (0.81 mm) diameter (AWG size 22, stranded) wires for resistors with .250 inch (6.35 mm) diameter operating shaft, and three .025 inch (0.64 mm) diameter (AWG 22 solid) wires for resistors with .125 inch (3.18 mm) diameter operating shafts. Terminals shall be suitably treated to facilitate soldering.

**3.4.4.1 Solder dip (retinning) Leads.** The manufacturer may solder dip/retin the leads of product supplied to this specification provided the solder dip process has been approved by the qualifying activity. The manufacturer shall maintain solder purity in accordance with table VI, during the tinning process.

TABLE VI. Contamination Limits.

| Contamination | Tinning percent by weight |
|---------------|---------------------------|
| Copper        | 0.750                     |
| Gold          | 0.500                     |
| Cadmium       | 0.010                     |
| Zinc          | 0.008                     |
| Aluminum      | 0.008                     |
| Antimony      | 0.500                     |
| Iron          | 0.020                     |
| Arsenic       | 0.030                     |
| Bismuth       | 0.250                     |
| Silver        | 0.750                     |
| Nickel        | 0.025                     |

**3.4.4.1.1 Qualifying activity approval.** Approval of the solder dip process will be based on one of the following options:

- a. When the original lead finish qualified was hot solder dip lead finish 52 of MIL-STD-1276 (NOTE: The 200 microinch maximum thickness is not applicable). The manufacturer shall use the same solder dip process for retinning as is used in the original manufacture of the product.
- b. When the lead originally qualified was not hot solder dip finish 52 of MIL-STD-1276 as prescribed in a, approval for the process to be used for solder dip shall be based on the following test procedure:
  - (1) Thirty samples of any resistance value for each style and lead finish are subjected to the manufacturer's solder dip process. Following the solder dip process, the resistors are subjected to the dc resistance test (and other group A electricals). No defects are allowed.
  - (2) Ten of the 30 samples are then subjected to the solderability test. No defects are allowed.
  - (3) The remaining 20 samples are subjected to the resistance to soldering heat test followed by the moisture resistance test. No defects are allowed.

**3.4.4.1.2 Solder dip retinning options.** The manufacturer may solder dip/retin as follows:

- a. After group A tests. Following the solder dip/retinning process, the electrical measurements required in group A, subgroup 1, tests shall be repeated on the lot. The group A, subgroup 1, lot rejection criteria shall be used. Following these tests, the manufacturer shall submit the lot to the group B solderability test as specified in 4.6.5.
- b. As a corrective action if the lot fails the group B solderability test.

**3.4.5 Solder.** Solder for electrical connections shall be in accordance with QQ-B-654 or QQ-S-571.

**3.4.6 Mounting.** Resistors shall be mounted by the single hole method with provisions for the nonturn device as specified (see 3.1).

## MIL-R-94E

3.4.6.1 Hardware. Each resistor shall be furnished with a corrosion resistant, internal tooth lock washer, a hexagonal mounting nut and a locking nut (if applicable), as specified (see 3.1). Hardware shall not be assembled on the resistor unless otherwise specified (see 6.2c). For direct Government orders, hardware shall be assembled on the resistor.

3.4.6.2 Standard bushings. When standard bushings are specified, the bushings shall be as shown for the applicable style of resistor (see 3.1).

3.4.6.3 Locking bushings. When locking bushings are specified, the bushings shall be as shown for the applicable style of resistor (see 3.1).

3.4.6.4 Shaft and panel sealed bushings. When shaft and panel sealed bushings are specified, the panel seal may be an integral part of the resistor or may be detachable (see 3.1).

3.4.6.5 Nonturn device. A nonturn device shall be furnished on resistors, which will prevent their rotation with respect to the surface on which they are mounted. The location of the nonturn device and its widest dimension shall be as specified (see 3.1). If the nonturn device is not symmetrical about its vertical axis, it shall be so placed that a plane passed perpendicular to the widest dimension and through its center shall pass through the axis of the operating shaft, and shall be an integral part of the resistor or permanently attached thereto.

3.4.7 Securing of screws, nuts, and threaded parts. All screw-thread assemblies shall be made resistant to loosening under vibration.

3.4.8 Enclosure. Resistors shall have suitable enclosures for protection against mechanical damage.

3.5 DC resistance (see 4.6.2).

3.5.1 Total resistance. Resistors shall have a total resistance equal to the nominal resistance value plus or minus the resistance tolerance specified (see 1.2.1.6, 1.2.1.7, and 4.6.2.1).

3.5.2 Resistance taper. A linear taper is one having constant change of resistance with angular rotation. The resistance taper shall conform in general shape to the normal curves shown on figures 3 and 4, as applicable. Resistance measurements shall fall within  $\pm 20$  percent of the nominal values shown by curves at the specified angle of 50 percent of electrical rotation (see figures 3 and 4, and 4.6.2.2).

3.5.3 Minimum resistance (see 4.6.2.3).

3.5.3.1 Taper A (linear) resistors. The minimum resistance at either extreme of the electrical rotation shall not exceed the values listed in table VII.

3.5.3.2 Tapers C and F (nonlinear) resistors. The minimum resistance shall not exceed the values listed in table VIII.

3.6 Torque (see 4.6.3).

3.6.1 Operating. The torque required to rotate the contact arm shall be as specified (see 3.1). An additional torque of 15 ounce-inches shall be permitted for operation of attached switches.

3.6.2 Stops. Resistors shall withstand the stop torque specified (see 3.1) without damage to the contact arm and stop.

3.6.3 Locking. Resistors with locking bushings shall withstand the locking torque specified (see 3.1), without damage to the bushings and threads. The contact arm shall not move when subjected to the test specified in 4.6.3.3.

3.7 Dielectric withstanding voltage. When resistors are tested as specified in 4.6.4, resistors or switches, as required, shall withstand the application of potentials without damage, arcing, or breakdown.

3.8 Solderability. When resistors are tested as specified in 4.6.5, resistors shall meet the criteria for tab evaluation in the test method.



## MIL-R-94E

3.9 Resistance to soldering heat. When resistors are tested as specified in 4.6.6, resistors shall show no mechanical damage and the change in resistance shall not exceed 2 percent.

3.10 Rotational life. When resistors are tested as specified in 4.6.7, the permanent change in resistance shall not exceed 10 percent, nor shall proper contact between the resistance element and the contact arm be broken during or as result of the test, and shall show no mechanical damage.

3.11 Switch life. Switches shall show no damage when they make, carry, and break the current as specified in 4.6.8. The contact resistance shall not exceed 0.10 ohm.

3.12 Load life. When resistors are tested as specified in 4.6.9, resistors shall show no evidence of mechanical damage and the change in total resistance between the initial reading and any subsequent reading shall not exceed 10 percent. The minimum resistance both before and after the test shall not exceed the applicable requirements for minimum resistance in tables VII and VIII, as applicable (see 3.5.3).

TABLE VII. Minimum resistance taper (taper A).

| Total resistance       | Maximum value of minimum resistance |
|------------------------|-------------------------------------|
| <u>Ohms</u>            | <u>Ohms</u>                         |
| 50 to 750, incl        | 5 1/2                               |
| 1,000 to 10,000, incl  | 25                                  |
| 15,000 to 50,000, incl | 35                                  |
| 75,000 to 0.1 megohm   | 50                                  |
| <u>Megohms</u>         |                                     |
| 0.15 to 0.25, incl     | 125                                 |
| 0.35 to 0.50, incl     | 250                                 |
| 0.75 to 1.00, incl     | 500                                 |
| 1.50 to 2.50, incl     | 1,000                               |
| 3.50 to 5.00, incl     | 1,500                               |

1/ Applicable to all styles except RV6.  
For values of RV6, see 3.1.

TABLE VIII. Minimum-resistance (C and F).

| Total resistance           | Clockwise maximum value of minimum resistance (measured between 3 and 2 terminals, see figure 1). |             | Counterclockwise maximum value of minimum resistance (measured between 1 and 2 terminals, see figure 1). |             |
|----------------------------|---|-------------|--|-------------|
|                            | Taper C   | Taper F     | Taper C  | Taper F     |
| <u>Ohms</u>                | <u>Ohms</u>   | <u>Ohms</u> | <u>Ohms</u>  | <u>Ohms</u> |
| 100 to 750 incl            | 20  | 5 1/2       | 5 1/2  | 20          |
| 1,000 to 5,000 incl        | 100   | 25          | 25   | 100         |
| 7,500 to 10,000 incl       | 200   | 25          | 25   | 200         |
| 15,000 to 25,000 incl      | 250   | 35          | 35   | 250         |
| 35,000 to 50,000 incl      | 500   | 35          | 35   | 500         |
| 75,000 to 0.1 megohm, incl | 1,000   | 35          | 35   | 1,000       |
| <u>Megohms</u>             |   |             |  |             |
| 0.15 to 0.25, incl         | 2,500   | 50          | 50   | 2,500       |
| 0.35 to 0.50, incl         | 5,000   | 100         | 100  | 5,000       |
| 0.75 to 1.00, incl         | 10,000  | 200         | 200  | 10,000      |
| 1.50 to 2.50, incl         | 25,000  | 500         | 500  | 25,000      |
| 3.50 to 5.00, incl         | 50,000  | 600         | 600  | 50,000      |

1/ Applicable to all styles except RV6. For value of RV6, see 3.1.

## MIL-R-94E

3.13 Moisture resistance. When resistors are tested as specified in 4.6.10, resistors shall show no evidence of mechanical damage. The maximum change in total resistance of any individual resistor shall not exceed the value specified in table III. The resistors shall meet the insulation resistance requirement specified in table III. The resistors shall meet the insulation resistance requirement specified in table III and shall withstand application of the dielectric potential (see 4.6.4) without damage, arcing, or breakdown.

3.14 Low temperature storage. When resistors are tested as specified in 4.6.11, the total resistance shall not change in excess of 2 percent.

3.15 Low temperature operation. When resistors are tested as specified in 4.6.12, the torque required to effect rotation of the contact arm shall not be greater than 30 ounce-inches for all styles except RV4 and 48 ounces-inches for style RV4. The total resistance shall not change in excess of 3 percent.

3.16 Thermal shock. When resistors are tested as specified in 4.6.13, resistor shall show no evidence of mechanical damage and electrical continuity shall not be affected. Rivets, if any, shall not loosen, and the change in total resistance of each resistor shall not exceed the values specified (see 3.1).

3.17 Salt spray (corrosion). When resistors are tested as specified in 4.6.14, resistors shall show no corrosion and shall remain mechanically operative.

3.18 Shock (specified pulse). When resistors are tested as specified in 4.6.15, there shall be no open circuits or intermittent contacts. The resistance shall not change in excess of 5 percent between terminals 1 and 2 and 2 percent between terminals 1 and 3. There shall be no evidence of mechanical damage.

3.19 Vibration, high frequency. When resistors are tested as specified in 4.6.16, there shall be no open circuits or intermittent contacts. The resistance shall not change in excess of 5 percent between terminals 1 and 2, and 2 percent between terminals 1 and 3. There shall be no evidence of mechanical damage.

3.20 Marking. Resistors shall be marked with the PIN and the manufacturer's name or trade mark. If space permits, the total resistance in ohms shall also be marked. The PIN shall be marked on either the rear or the periphery of resistors. There shall be no space between symbols which comprise the PIN. If lack of space requires it, the PIN may be set in two lines. In this event, the PIN shall be divided between the temperature and moisture-resistance characteristic and shaft designations, as shown in the following example:

RV2NAY  
SD103A

Marking shall remain legible at the end of all tests.

3.21 Workmanship. Resistors shall be processed in such a manner as to be uniform in quality and shall meet the requirements of 3.3 to 3.4.4, 3.4.5 to 3.4.8, inclusive, and 3.20 to 3.22, inclusive, as applicable, and shall be free from other defects that will affect life, serviceability, or appearance.

3.21.1 Soldering. When soldering is employed, only substantially noncorrosive fluxes shall be used, unless it can be shown that corrosive elements have been satisfactorily removed after soldering. Solder shall not be used primarily for obtaining mechanical strength. Electrical connections shall be mechanically secure before and electrically continuous after soldering.

3.22 Fungus. All external materials shall be nonnutrient to fungus growth or shall be suitably treated to retard fungus growth. The manufacturer shall verify by certification that all external materials are fungus resistant or shall test resistors as specified in 4.6.17. There shall be no evidence of fungus growth on the external surfaces.

#### 4. QUALITY ASSURANCE PROVISIONS

4.1 Responsibility for inspection. Unless otherwise specified in the contract or purchase order, the contractor is responsible for the performance of all inspection requirements as specified herein. Except as otherwise specified in the contract or purchase order, the contractor may use his own or any other facilities suitable for the performance of the inspection requirements specified herein, unless disapproved by the Government. The government reserves the right to perform any of the inspections set forth in the specification where such inspections are deemed necessary to assure supplies and services conform to prescribed requirement.

## MIL-R-94E

**4.1.1 Responsibility for compliance.** All items shall meet all requirements of sections 3 and 5. The inspection set forth in this specification shall become a part of the contractor's overall inspection system or quality program. The absence of any inspection requirements in the specification shall not relieve the contractor of the responsibility of ensuring that all products or supplies submitted to the Government for acceptance comply with all requirements of the contract. Sampling inspection, as part of manufacturing operations, is an acceptable practice to ascertain conformance to requirements, however, this does not authorize submission of known defective material, either indicated or actual, nor does it commit the Government to accept defective material.

**4.1.2 Test equipment and inspection facilities.** Test and measuring equipment and inspection facilities of sufficient accuracy, quality and quantity to permit performance of the required inspection shall be established and maintained by the supplier. The establishment and maintenance of a calibration system to control the accuracy of the measuring equipment shall be in accordance with MIL-STD-45662.

**4.2 Classification of inspections.** Inspection requirements specified herein are classified as follows:

- a. Qualification inspection (see 4.4).
- b. Quality conformance inspection (see 4.5).

**4.3 Inspection conditions.** Unless otherwise specified herein, all inspections shall be performed in accordance with the test conditions specified in the "GENERAL REQUIREMENTS" of MIL-STD-202.

**4.4 Qualification inspection.** Qualification inspection shall be performed at a laboratory acceptable to the Government (see 6.3) on sample units produced with equipment and procedures normally used in production.

**4.4.1 Sample size.** The number of resistors to be subjected to qualification inspection shall be as specified in the appendix to this specification.

**4.4.2 Inspection routine.**

**4.4.2.1 Single type submission.** The sample shall be subjected to the examinations and tests specified in table IX, in the order shown. Six sample units shall be subjected to the examination and tests of group I. An additional six sample units shall be subjected to group II. All sample units, except those subjected to group II, shall then be placed in a dry oven and maintained for 24 ± 4 hours at a temperature of 40°C ± 5°C, then removed and placed in a desiccator using a suitable desiccant, such as activated alumina or silica gel, before being subjected to the tests of groups III to VIII, inclusive. The six sample units subjected to the examination and tests of group I shall also be subjected to the tests of group III. Twenty-four of the remaining sample units shall be equally divided into four groups and subjected to the tests of groups IV to VII, inclusive. Ten sample units shall be subjected to the tests of group VIII. Ten sample units shall be submitted to group IX (see 3.22).

**4.4.2.2 Combined type submission.** The sample shall be subjected to the examination and tests specified in table IX or X, as applicable, in the order as shown. The sample units shall be assigned to groups in accordance with table XIX or XX, as applicable. After examination and tests of group I and II, all resistors, except those subjected to group II shall be placed in a dry oven and maintained for 24 ± 4 hours at a temperature 40°C ± 5°C, then removed and placed in a desiccator using a suitable desiccant such as activated alumina or silica gel, before being subjected to the tests of groups III to VIII, inclusive, of table XIX or groups II or III, of table XX, as applicable. Ten sample units shall be submitted to group IX.

**4.4.3 Defective.** Defectives in excess of those allowed in table IX and X, shall be cause for refusal to grant qualification.

**4.4.4 Retention of qualification.** To retain qualification, the supplier shall forward at 6-month intervals to the qualifying activity. The qualifying activity shall establish the initial reporting date. The report shall consist of:

- a. A summary of the results of the tests performed for inspection of product for delivery, (groups A and B), indicating as a minimum the number of lots that have passed and the number that have failed. The results of the tests of all reworked lots shall be identified and accounted for.

## MIL-R-94E

- b. A summary of the results of tests performed for qualification verification inspection, (group C including the number and mode of failures. The summary shall include results of all qualification verification inspection test performed and completed during the 6-month period. If summary of the test results indicates nonconformance with specification requirements, and corrective action acceptable to the qualifying activity has not been taken, action will be taken to remove the failing product from the qualified products list.

TABLE IX. Qualification inspection.

| Examination or test   | Requirement paragraph  | Method paragraph | Number of failures allowed <sup>1/</sup> |
|---|--|------------------|--|
| <u>Group I</u><br>Visual and mechanical examination <sup>2/</sup> | 3.1, 3.3 to 3.4.4<br>incl, 3.4.5 to<br>to 3.4.8 incl.<br>3.20 to 3.22 incl | 4.6.1            | 0  |
| DC resistance   | 3.5  | 4.6.2            |  |
| Torque  | 3.6  | 4.6.3            |  |
| Dielectric withstanding voltage                                   | 3.7  | 4.6.4            |  |
| <u>Group II</u><br>Solderability <sup>3/</sup>                    | 3.8  | 4.6.5            | 1  |
| <u>Group III</u><br>Resistance soldering heat                     | 3.9  | 4.6.6            | 1  |
| Rotational life   | 3.10   | 4.6.7            |  |
| Switch Life <sup>4/</sup>   | 3.11   | 4.6.8            |  |
| <u>Group IV</u><br>Load life                                      | 3.12   | 4.6.9            | 1  |
| <u>Group V</u><br>Moisture resistance                             | 3.13   | 4.6.10           | 1  |
| <u>Group VI</u><br>Low temperature storage                        | 3.14   | 4.6.11           | 1  |
| Low temperature operation   | 3.15   | 4.6.12           |  |
| Thermal shock   | 3.16   | 4.6.13           |  |
| <u>Group VII</u><br>Salt spray (corrosion)                        | 3.17   | 4.6.14           | 1  |
| <u>Group VIII</u><br>Shock (specified pulse)                      | 3.18   | 4.6.15           | 0  |
| Vibration, high frequency   | 3.19   | 4.6.16           |  |
| <u>Group IX</u><br>Fungus   | 3.22   | 4.6.17           | 0  |

<sup>1/</sup> Failure of a resistor in one or more tests of a group shall be charged as a single defective.

<sup>2/</sup> Marking shall be considered defective only if the marking is illegible.

<sup>3/</sup> Sample units subjected to group II shall not have been subjected to group I.

<sup>4/</sup> Not applicable to locking bushings type resistors.

## MIL-R-94E

TABLE X. Qualification inspection for locking-bushing-type resistors. 1/

| Examination or test                                    | Requirement paragraph  | Method paragraph | Number of failures allowed 2/ |
|--|--|------------------|-------------------------------|
| <u>Group I</u><br>Visual and mechanical examination 3/ | 3.1, 3.3 to 3.4.4<br>incl, 3.4.5 to<br>3.4.8 incl, 3.20<br>to 3.22 incl, | 4.6.1            | } 0                           |
| DC resistance  | 3.5  | 4.6.2            |                               |
| Torque   | 3.6  | 4.6.3            |                               |
| <u>Group II</u><br>Moisture resistance                 | 3.13   | 4.6.10           | } 1                           |
| <u>Group III</u><br>Rotational life                    | 3.10   | 4.6.7            |                               |

- 1/ This inspection is applicable only to 12 additional locking bushing type resistors when submitted with the standard bushing type.
- 2/ Failure of an individual resistor in one or more tests of a group shall be charged as a single defective.
- 3/ Marking shall be considered defective only if marking is illegible after completion of any the required inspection.

Failure to submit the report within 30 days after the end of each 6-month period may result in loss of qualification for the product. In addition to the periodic submission of inspection data, the supplier shall immediately notify the qualifying activity at any time during the 6-month period that the inspection data indicates failure of the qualified product to meet the requirements of this specification.

In the event that no production occurred during the reporting period, a report shall be submitted certifying that the company still has the capabilities and facilities necessary to produce the item. If during two consecutive reporting periods there has been no production, the manufacturer may be required, at the discretion of the qualifying activity, to submit a representative product of each style and characteristic to testing in accordance with the qualification requirements.

#### 4.5 Quality conformance.

4.5.1 Inspection of product for delivery. Inspection of product for delivery shall consist of groups A and B inspection.

4.5.1.1 Inspection lot. Inspection lot as far as practicable, shall consist of all resistors of the same style produced in a period not to exceed 30 days, produced under essentially the same conditions, and offered for inspection at one time.

4.5.1.2 Group A inspection. Group A inspection shall consist of the examination and tests specified in table XI, and shall be made on the same set of sample units, in the order shown.

##### 4.5.1.2.1 Sampling plan.

4.5.1.2.1.1 Subgroup 1. A sample of parts from each inspection lot shall be randomly selected in accordance with table XII. If one or more defects are found, the lot shall be reworked or screened and defectives removed. After reworking or screening of the lot and removal of defectives, a new sample of parts shall be randomly selected in accordance with table XII. If one or more defects are found in this second sample, the lot shall be rejected and shall not be supplied to this specification. Resistance values in the samples shall be representative, and where possible, in proportion to the resistors in the inspection lot.

## MIL-R-94E

TABLE XI. Group A inspection.

| Examination or test                                    | Requirement paragraph  | Method paragraph | Sampling plan      |
|--|--|------------------|--------------------|
| <u>Subgroup 1</u><br>Total resistance                  | 3.5.1  | 4.6.2.1          | See<br>4.5.1.2.1.1 |
| <u>Subgroup 2</u><br>Visual and mechanical examination | 3.1, 3.3 to<br>3.4.4, 3.4.5 to<br>to 3.4.8 incl.,<br>and 3.20 to<br>3.22 incl. | 4.6.1            | See<br>4.5.1.2.1.2 |
| <u>Subgroup 3</u><br>Solderability                     | 3.8  | 4.6.5            | See<br>4.5.1.2.1.3 |

TABLE XII. Group A sampling plan.

| Lot size           | Subgroup 1<br>sampling plan | Subgroup 2<br>sampling plan |
|--------------------|-----------------------------|-----------------------------|
| 1 to 8             | 100 percent                 | 100 percent                 |
| 9 to 90            | 100 percent                 | 13                          |
| 91 to 150          | 125                         | 13                          |
| 151 to 280         | 192                         | 20                          |
| 281 to 500         | 192                         | 29                          |
| 501 to 1,200       | 192                         | 34                          |
| 1,201 to 3,200     | 192                         | 42                          |
| 3,201 to 10,000    | 192                         | 50                          |
| 10,001 to 35,000   | 294                         | 60                          |
| 35,001 to 150,000  | 294                         | 74                          |
| 150,001 to 500,000 | 345                         | 90                          |
| 500,001 and over   | 435                         | 102                         |

4.5.1.2.1.2 Subgroup 2. A sample of parts from each inspection lot shall be randomly selected in accordance with table XII. If one or more defects are found, the lot shall be reworked or screened and defectives removed. After reworking or screening of the lot and removal of defectives, a new sample of parts shall be randomly selected in accordance with table XII. If one or more defects are found in the second sample, the lot shall be rejected and shall not be supplied to this specification.

4.5.1.2.1.3 Subgroup 3 (solderability).

4.5.1.2.1.3.1 Sampling plan. Five samples (13 samples for RV8) shall be selected randomly from each inspection lot and subjected to the subgroup 3 solderability test. If there are one or more defects, the lot shall be considered to have failed.

4.5.1.2.1.3.2 Rejected lots. In the event of one or more defects, the inspection lot is rejected. The manufacturer may use one of the following options to rework the lot:

- a. Each production lot that was used to form the failed inspection lot shall be individually submitted to the solderability test as required in 4.6.5. Production lots that pass the solderability test are available for shipment. Production lots failing the solderability test can be reworked only if submitted to the solder dip procedure in b.

## MIL-R-94E

- b. The manufacturer submits the failed lot to a 100 percent solder dip using an approved solder dip process in accordance with 3.4.4.1. Following the solder dip the electrical measurements required in group A, subgroup 2 tests shall be repeated on 100 percent of the lot. The Percent Defective Allowable (PDA) for the electrical measurements shall be as for the subgroup 1 tests. Five (5) samples for RVB) additional samples shall then be selected and subjected to the solderability test with zero defects allowed. If the lot fails this solderability test, the lot shall be considered rejected and shall not be furnished against the requirements of this specification.

4.5.1.2.1.3.3 Disposition of samples. The solderability test is considered a destructive test and samples submitted to the solderability test shall not be supplied on the contract.

4.5.1.3 Group B inspection. Group B inspection shall consist of the tests specified in table XIII, in the order shown, and the sample shall be selected from inspection lots that have passed group A inspection.

TABLE XIII. Group B inspection.

| Examination or test             | Requirement paragraph | Method paragraph |
|---------------------------------|-----------------------|------------------|
| Resistance taper                | 3.5.2                 | 4.6.2.2          |
| Minimum resistance              | 3.5.3                 | 4.6.2.3          |
| Torque                          | 3.6                   | 4.6.3            |
| Dielectric withstanding voltage | 3.7                   | 4.6.4            |

4.5.1.3.1 Sampling plan. A sample of parts from each inspection lot shall be randomly selected in accordance with table XIV, if one or more defects are found, the lot shall be rescreened and defects removed. After reworking or screening of the lot and removal of defectives, a new sample of parts shall be randomly selected in accordance with table XIV. If one or more defects are found in the second sample, the lot shall not be supplied to this specification.

TABLE XIV. Group B sampling plan

| Lot size         | Sample size |
|------------------|-------------|
| 1 to 25          | 3           |
| 26 to 50         | 5           |
| 51 to 90         | 6           |
| 91 to 150        | 7           |
| 151 to 280       | 10          |
| 281 to 500       | 11          |
| 501 to 1,200     | 15          |
| 1,201 to 3,200   | 18          |
| 3,201 to 10,000  | 22          |
| 10,001 to 35,000 | 29          |
| 35,001 and over  | 29          |

4.5.1.3.2 Disposition of sample units. Sample units which have passed all the group B inspection may be delivered on the contract or purchase order, if the lot is accepted.

## MIL-R-94E

TABLE XV. Group C inspection.

| Examination or test          | Requirement paragraph | Method paragraph | Number of samples tested | Number of failures allowed |
|------------------------------|-----------------------|------------------|--------------------------|----------------------------|
| <u>Monthly</u>               |                       |                  |                          |                            |
| <u>Subgroup 1</u>            |                       |                  |                          |                            |
| Low temperature storage      | 3.14                  | 4.6.11           | 6                        | 1                          |
| Low temperature operation    | 3.15                  | 4.6.12           |                          |                            |
| Thermal shock                | 3.16                  | 4.6.13           |                          |                            |
| <u>Subgroup 2</u>            |                       |                  |                          |                            |
| Resistance to soldering heat | 3.9                   | 4.6.6            | 6                        | 1                          |
| Rotational life              | 3.10                  | 4.6.7            | 6                        |                            |
| <u>Quarterly</u>             |                       |                  |                          |                            |
| <u>Subgroup 1</u>            |                       |                  |                          |                            |
| Moisture resistance          | 3.13                  | 4.6.10           | 6                        | 1                          |
| <u>Subgroup 2</u>            |                       |                  |                          |                            |
| Shock, (specified pulse)     | 3.18                  | 4.6.15           | 10                       | 0                          |
| Vibration, high frequency    | 3.19                  | 4.6.16           |                          |                            |
| <u>Semiannual</u>            |                       |                  |                          |                            |
| <u>Subgroup 1</u>            |                       |                  |                          |                            |
| Load Life                    | 3.12                  | 4.6.9            | 6                        | 1                          |
| <u>Subgroup 2</u>            |                       |                  |                          |                            |
| Salt spray corrosion         | 3.17                  | 4.6.14           | 2                        |                            |

4.5.2 Periodic inspection. Periodic inspection shall consist of group C. Except where the results of these inspections shown noncompliance with the applicable requirements (see 4.5.2.1.3), delivery of products which have passed groups A and B shall not be delayed pending the results of these qualification verification inspections.

4.5.2.1 Group C inspection. Group C inspection shall be performed monthly, quarterly and semiannually and shall consist of the tests specified in table XV, in the order shown. They shall be performed on sample units that have passed group A inspection.

4.5.2.1.1 Sampling plan. Sample units in each style currently in production shall be selected. The number of sample units to be inspected shall be as specified in table XV. Separate samples of the size required by table XV shall be used for each subgroup listed. In the monthly tests, one defective unit shall be allowed. In the quarterly tests, one defective unit shall be allowed for subgroup 1 and no defectives allowed for subgroup II. In the semiannual tests, one defective unit shall be allowed.

4.5.2.1.2 Disposition of sample units. Sample units subjected to group C inspection shall not be delivered on the contract or purchase order.

4.5.2.1.3 Noncompliance. If a sample fails to pass group C inspection, the manufacturer shall notify the qualifying activity and cognizant inspection activity of such a failure and take corrective action on the materials or processes, or both, as warranted, and on all units of production which can be corrected and which were manufactured under essentially the same materials and processes, and which are considered subject to the same failure. Acceptance and shipment of the product shall be discontinued until corrective action has been taken. Group B inspection shall be repeated on additional sample units (all inspections, or the inspection which the original sample failed, at the option of the qualifying activity). Groups A inspection may be reinstated; however, final acceptance and shipment shall be withheld until the group C inspection has shown that the corrective action was successful. In the event of failure after reinspection, information concerning the failure shall be furnished to the cognizant inspection activity and the qualifying activity.



## MIL-R-94E

4.5.3 Inspection of packaging. The sampling and inspection of the preservation, packing, and container marking shall be in accordance with the requirements of MIL-R-39032.

4.6 Methods of inspection.

4.6.1 Visual and mechanical examination. Resistors shall be examined to verify that the materials, design, construction, physical dimensions, marking, and workmanship are in accordance with the applicable requirements (see 3.3 to 3.4.4, 3.4.5 to 3.4.8, inclusive, and 3.20 to 3.22 inclusive).

4.6.2 DC resistance (see 3.5). Resistors shall be tested in accordance with method 303 of MIL-STD-202. The following details shall apply:

- a. Measuring apparatus: Measuring instruments used for initial and final readings of this test, can be of different styles or models provided the performance is equivalent. All test equipment shall be calibrated in accordance with MIL-STD-45662.
- b. Measurement energy for electronic test equipment: The measurement energy applied to the unit under test shall not exceed 10 percent of the 25°C rated wattage times 1 second.
- c. Limit of error of measuring apparatus: Shall not exceed  $\pm 0.5$  percent for qualification inspection nor  $\pm 1$  percent for quality conformance inspection.
- d. Test voltage for bridges: Measurements of resistance shall be made by using the test voltage specified in table XVI. The test voltage chosen, whether it be the maximum or a lower voltage which would still provide the sensitivity required, shall be applied across the terminals of the resistor. This same voltage shall be used whenever a subsequent resistance measurement is made.

TABLE XVI. DC resistance test voltage.

| Total resistance nominal        | Maximum test voltage |
|---------------------------------|----------------------|
| <u>ohms</u><br>100 to 999, incl | <u>Volts</u><br>2    |
| 1,000 to 9,999, incl            | 4                    |
| 10,000 to 99,999, incl          | 15                   |
| 0.1 megohm and over             | 40                   |

4.6.2.1 Total resistance (see 3.5.1). The total resistance of resistors shall be measured between the terminals of the resistance element with the contact arm against either stop for taper A and against the stop at the low resistance end for tapers C and F. The resistance value obtained shall be compared with the specified nominal total resistance.

4.6.2.2 Resistance taper (see 3.5.2). Following the measurement of total resistance, a resistance measurement shall be made at 50 percent of electrical rotation. The contact arm may be varied  $\pm 3$  percent of total electrical rotation from the specified angle of 50 percent rotation to meet the resistance tolerance of  $\pm 20$  percent.

4.6.2.3 Minimum resistance (see 3.5.3). The contact arm shall be rotated to its extreme counterclockwise limit of mechanical rotation. With the arm in this position, the resistance between the counterclockwise terminal and rotating contact terminal shall be measured. The contact arm shall then be rotated to its extreme clockwise limit of mechanical rotation. With the arm in this position, the resistance between the clockwise terminal and the rotating contact terminal shall be measured (with the switch on) at the exact point where the shaft actuator makes contact with the switch actuator.

4.6.3 Torque (see 3.6).

4.6.3.1 Operating. The torque required to rotate the contact arm of the resistance element shall be determined throughout the entire range of mechanical rotation by the torque wrench method or by any other method satisfactory to the Government.

## MIL-R-94E

4.6.3.2 Stop. Resistors shall be mounted on a metal panel by their normal mounting means. The contact arm shall then be rotated to each extreme limit of mechanical rotation and the specified torque (see 3.1) applied through the operating shaft to the stops.

4.6.3.3 Locking. Resistors shall be mounted on a metal panel by their normal mounting means and the locking device tightened with a torque wrench not greater than that specified (see 3.1).

4.6.4 Dielectric withstanding voltage (see 3.7).

4.6.4.1 Atmospheric pressure. Resistors shall be tested in accordance with method 301 of MIL-STD-202. The following details shall apply:

- a. Special preparation: Resistors shall be mounted on metal plates of sufficient size to extend beyond the resistor extremities, and such a manner that measurements can be made between terminals tied together and any other external metal parts.
- b. Magnitude of test voltage: 900 volts rms (for RV6, 750 volts).
- c. Nature of potential: From alternating current (ac) supply at commercial line frequency and wave form.
- d. Points of application of test voltage: Between the terminals tied together and all external metal portions of the resistors and metal mounting plate.
- e. Examination and measurements: During the tests, the leakage current shall be monitored and the resistors examined for evidence of arcing and breakdown. At the conclusion of the test, resistors shall be examined for evidence of damage.

4.6.4.2 Barometric pressure. Resistors shall be tested in accordance with method 105 of MIL-STD-202. The following details and exceptions shall apply:

- a. Method of mounting: As specified in 4.6.4.1a.
- b. Test condition: B.
- c. Period of time at reduced pressure prior to application of potential: 1 minute.
- d. Tests during subjection to reduced pressure: Voltage as specified (see 3.1) from an ac supply at commercial line frequency and waveform shall be applied for 1 minute.
- e. Points of application: As specified in 4.6.4.1d.
- f. Examinations and measurements: As specified in 4.6.4.1e.

4.6.5 Solderability (see 3.8). Resistors shall be tested in accordance with method 208 of MIL-STD-202. The following details shall apply:

- a. All three terminals shall be tested.
- b. No special preparation of leads is required.
- c. Steam aging shall apply.
- d. Terminals shall be dipped within .125 inch (3.18 mm) of body. All three terminals shall be dipped simultaneously whenever possible. When configuration is such that terminals cannot be dipped simultaneously, the .125 inch (3.18 mm) shall apply to the terminal on whichever it occurs first when all three terminals are dipped in an orientation which most nearly meets the above requirement.
- e. Evaluation for tab terminals shall apply.

## MIL-R-94E

4.6.6 Resistance to soldering heat (see 3.9). Resistors shall be tested in accordance with method 210 of MIL-STD-202. The following details shall apply:

- a. Measurement before test: DC resistance shall be measured as specified.
- b. The temperature of the solder shall be  $350 \pm 10^\circ\text{C}$ , and the duration of immersion shall be  $5 \pm 0.5$  seconds.
- c. Depth of immersion in the molten solder: To a point .125 inch (3.18 mm) from the entry of the terminal into resistor body for resistor for resistors .250 inch (6.35 mm) in diameter operating shaft and .0625 (1.59 mm) for resistors of .125 inch (3.18 mm) diameter operating shaft.
- d. Measurement after test:  $4 \pm 0.5$  hours after completion of test, the dc resistance shall be measured as specified in 4.6.2. Resistors shall be examined for evidence of mechanical damage.

4.6.7 Rotational life (see 3.10). Resistors shall be placed in an a dry oven maintained at a temperature of  $40 \pm 5^\circ\text{C}$ , for a period of  $24 \pm 4$  hours. Following the removal from the oven, resistors shall be rotated 25 times to remove any film, if any, under the contact arm. The total resistance of each resistor shall be measured. Resistor shafts shall be continuously oscillated through not less than 90 percent of the total mechanical rotation at a rate of approximately 10 cycles per minute, for a total of 25,000 cycles. The locking-type resistors shall be rotated only 500 cycles. The rate of rotation for quality conformance inspection shall be 10 to 50 cycles per minute. Taper A resistors shall be ganged in pairs and the resistors in each pair shall be connected in series so that a nominally constant current flows through the resistors irrespective of the contact arm positioning during the rotation of the shaft, as shown on figure 5. Care shall be taken to insure that side thrust is minimized by proper alignment of the resistor shafts with the drive shafts. When performing this test on locking bushing type resistors, the locking nut shall be removed. The shafts shall be so connected mechanically that they turn simultaneously in the same direction. The potential applied during this test shall be obtained from a dc supply and shall be rated continuous working voltage of the resistor (see 3.1). Resistors shall be monitored to ascertain that proper contact is made during and throughout the course of the test. No potential shall be applied to tapers C and F resistors. Total resistance shall be measured at the end of cycling. At the conclusion of this test, resistors shall again be placed in a dry oven maintained at  $40^\circ\text{C}$  for  $24 \pm 4$  hours. Following removal from the oven, the total resistance shall again be measured and the percent of change in resistance from the initial measurement shall be computed.

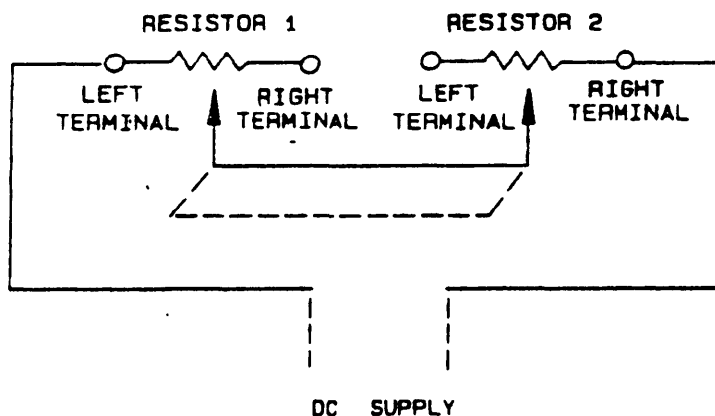

FIGURE 5. Rotational life test circuit.

## MIL-R-94E

4.6.8 Switch life (see 3.11)(not applicable to locking bushing type resistors). A 3.0 ampere current, flowing through a carbon lamp or a wire-wound resistor load with an ac. rms potential of 117 volts  $\pm 10$  percent applied, shall be interrupted 5,000 times by the operation of the switch. Switch contact resistance shall be measured both before and after the test. This test may be conducted concurrently with the rotational life test specified in 4.6.7.

4.6.9 Load life (see 3.12). Resistors shall be tested in accordance with method 108 of MIL-STD-202. The following details and exceptions shall apply:

- a. Method of mounting: By means of their mounting bushings with terminals positioned downward, in the center of a vertical No. 16 gauge, steel panel, 4 inches square in still air. Still air is surrounding air with no circulation other than that created by the heat of the resistor being operated. No shielding shall be located closer than 12 inches from the panel.
- b. Test temperature and tolerance:  $70 \pm 5^\circ\text{C}$ .
- c. Initial measurement: Minimum resistance at  $25^\circ\text{C} +10^\circ$ ,  $-5^\circ\text{C}$  (see 4.6.2.3). Following this measurement, the ambient temperature shall be held at the test temperature for  $24 \pm 4$  hours without load. At the end of this period, total resistance shall be measured. This measurement shall be the initial test measurement which shall be used as a reference for all future measurements of total resistance.
- d. Operating conditions: Rated dc continuous working voltage as specified in (see 3.1), shall be applied intermittently 1.5 hours on and 0.5 hours off for a total of 1,000 hours through the contact arm located against either stop and one resistance element terminal for taper A, and against the stop at the low resistance end and one resistance element for tapers C and F, so that rated wattage is dissipated across the entire resistance element. Adequate precautions shall be taken to maintain constant voltage on resistors under test.
- e. Test condition: D.
- f. Measurements during test: Resistance measurements shall be made at the end of the 0.5 hour off periods after  $100 \pm 8$ ,  $200 \pm 8$ ,  $500 \pm 48$ ,  $\infty$  hours have elapsed and compared to the similar readings taken in c.
- g. Measurements after test: The resistors shall be returned to an ambient temperature of  $25 +10$ ,  $-5^\circ\text{C}$ , and the minimum resistance shall be measured within not less than 2 hours nor more than 4 hours.

4.6.10 Moisture resistance (see 3.13). Resistors shall be tested in accordance with method 106 of MIL-STD-202. The following details and exceptions shall apply:

- a. Mounting: By their bushings on a suitable metal panel with the operating shaft in a horizontal position and radial terminals pointed downward. Vibration shall be performed either in a vertical or horizontal plane.
- b. Initial measurements: Total resistance shall be measured between terminal 1 and the contact arm terminal with the operating shaft rotated to the maximum clockwise position (see figure 2).
- c. Load: During steps 1 and 4, rated (100 percent) wattage or maximum rated dc voltage, whichever is smaller, shall be applied for the first 2 hours of each step.
- d. Method of applying load voltage: Across terminal 1 and the contact arm terminal, with operating shaft rotated to the maximum clockwise position (see figure 2).

## MIL-R-94E

- e. **Final measurements:** At the end of the final cycle and while the resistors are still in the humidity chamber at the high humidity condition, total resistance shall be measured as specified in b. above. Following this measurement, the humidity chamber may be opened in order to make the necessary electrical connections to perform the dielectric withstanding voltage and insulation resistance tests. The chamber shall then be returned to the high humidity condition and maintained at this condition for at least 1 hour prior to these tests. Dielectric withstanding voltage shall be tested as specified in 4.6.4.1 except that the operating shaft shall not be rotated during the test, electrification time shall be 2 minutes, and the test potential applied to styles RV5 and RV6 shall be 500 volts. Insulation resistance shall then be measured between the resistor terminals tied together and mounting bushing, using a dc potential of 500 volts. The subsequent 4- to 24-hour conditioning period and measurements do not apply.

4.6.11 **Low temperature storage (see 3.14).** The total resistance shall be measured at 25°C +10°C, -5°C. Within 1 hour after this measurement, resistors shall be placed in a chamber at a temperature of 25°C +10°C, -5°C. The temperature in this chamber shall be lowered to -63°C +0°C, -2°C within a minimum period of 3 hours. Twenty-four hours after the resistors have reached this temperature, the temperature of the chamber shall be gradually raised to 25°C +10°C, -5°C within a maximum period of 8 hours. Resistors shall then be removed from the chamber and maintained at 25°C +10°C, -0°C for a period of approximately 24 hours, after which the total resistance shall be measured.

4.6.11.1 **Quality conformance inspection.** For quality conformance inspection and at the option of the manufacturer, the sample units may be placed in or removed from the test chamber while the chamber is at the extreme low temperature.

4.6.12 **Low temperature operation (see 3.15).** The total resistance shall be measured at 25°C +10°C, -5°C. The resistors shall then be placed in a chamber at 25°C +10°C, -5°C and the temperature in the chamber shall be lowered to -55°C +0°C, -5°C with a minimum period of 1.5 hours. After 1 hour ±15 minutes of stabilization at this low temperature, rated continuous working voltage (see 3.1), shall be applied for 45 minutes across the resistance element between one end terminal and the contact arm terminal. The resistors shall then be allowed to stabilize for 1 hour ±15 minutes and the torque necessary to effect rotation of the contact arm shall be measured. Following this measurement, the temperature shall be gradually raised to 25°C +10°C, -5°C within a period of 8 hours. The resistors shall then be removed from the chamber and maintained at 25°C +10°C, -5°C for approximately 24 hours, after which the total resistance shall be measured (see 3.1).

4.6.13 **Thermal shock (see 3.16).**

4.6.13.1 **Mounting.** Resistors shall be mounted by their mounting bushings in such a manner that there is at least 1 inch free air space around each resistor, and with the mounting in such position with respect to the air stream that it offers the least obstruction to the flow of air across and around the resistors.

4.6.13.2 **Cycling.** Sample units shall be conditioned at 70°C ±5°C for 24 ±4 hours. The sample units shall be returned to room ambient (25°C ±5°C) and allowed to stabilize. After stabilization, the initial resistance readings shall be taken. The sample units shall then be subjected to the applicable thermal shock shown in table XVII for a total of five cycles performed continuously. In transferring the sample units from one chamber to another, they shall not be subjected to circulating air. The air temperature of the two chambers shall be held at each of the extreme temperatures by means of circulation and sufficient hot or cold chamber capacity so that air at the sample units will reach the temperature specified within 2 minutes after they have been transferred to the appropriate chamber. The final resistance reading shall be taken at the end of thermal shock at 25°C ±5°C after the samples have been stabilized.

## MIL-R-94E

TABLE XVII. Thermal shock.

| Steps              | Temperature | Time          |
|--------------------|-------------|---------------|
|                    | °C          |               |
| 1... <sup>1/</sup> | -55 +0, -3  | Minimum<br>30 |
| 2....              | 25 +10, -5  | 10 to 15      |
| 3....              | 120 +3, -0  | 30            |
| 4....              | 25 +10, -5  | 10 to 15      |

<sup>1/</sup> For quality conformance inspection and at the option of the manufacturer, this temperature may be -63°C +0°C, -2°C.

NOTE: At the option of the manufacturer the reverse sequence may be as follows:

1. Room temperature
2. +120 ±3
3. Room temperature
4. -55 ±3

4.6.14 Salt spray (corrosion)(see 3.17). Resistors shall be mounted on an aluminum panel and tested in accordance with method 101, test condition A, of MIL-STD-202. Following removal from the chamber, the resistors shall be thoroughly washed for 1 minute in free running tap water, the temperature of which shall not exceed 38°C. The resistors shall then be placed in an oven and maintained at 50°C ±3°C for a period of 24 ±4 hours. At the end of this period, resistors shall be removed from the oven and examined for corrosion and mechanical operation.

4.6.15 Shock (specified pulse)(see 3.18). Resistors shall be tested in accordance with method 213 of MIL-STD-202. The following details and exceptions shall apply:

- a. Resistors shall be mounted by their normal mounting means and affixed on an appropriate mounting fixture. A suggested mounting fixture is shown on figure 7. The mounting fixture shall be constructed in such a manner as to insure that the mounting supports remain in a static condition with reference to the shock test table. Test leads used during this test shall be as small a wire size as practicable (e.g., AWG 22 stranded) so the influence of the test lead on the resistor will be held to a minimum. The test lead length shall be no longer than necessary. In all cases, the resistors shall be mounted in relation to the test equipment in such a manner that the stress applied is in the direction which would be considered most detrimental. The contact arm shall be positioned at 50 percent of mechanical rotation. The locking bushing styles shall be in the locking position.
- b. Measurements after mounting: Resistors shall be measured as specified in 4.6.2. The resistance shall be measured between the contact arm terminal and terminal 1, and between terminals 1 and 3.
- c. Test condition: I.
- d. Motion: Resistors shall be subjected to a total of 20 impacts (five blows in each of two directions in each of two mutually perpendicular planes). One of the test planes used shall be perpendicular and the other parallel to the longitudinal axis of the operating shaft.
- e. Measurement during test: Each resistor shall be monitored to determine momentary discontinuity by a method which shall at least be sensitive enough to monitor or register automatically any momentary discontinuity of 0.1 millisecond or greater duration.
- f. Measurements and examination after test: Resistors shall be measured as specified in 4.6.2. The resistance shall be measured between the contact arm terminal and terminal 1, and between terminals 1 and 3. Resistors shall then be examined for evidence of mechanical damage.

## MIL-R-94E

4.6.16 Vibration, high frequency (see 3.19). Resistors shall be tested in accordance with method 204 of MIL-STD-202. The following details and exceptions shall apply:

- a. Mounting: By normal mounting means and affixed to an appropriate nonresonant mounting fixture. A suggested mounting fixture is shown on figure 7. The mounting fixture shall be constructed in such a manner as to insure that the points of the resistor mounting supports shall have the same motion as the vibration test table. Test leads used during this test shall be as small as practicable (e.g., AWG size 22, stranded) so that the influence of the test lead on the resistor shall be held to a minimum. The test lead lengths shall be no longer than necessary. A shielded cable which may be necessary because of the field surrounding the vibration test table, shall be clamped to the mounting fixture. In all cases, resistors shall be mounted in relation to the test equipment in such a manner that the stress applied is in the direction which would be considered the most detrimental. The contact arm shall be positioned at 50 percent of mechanical rotation. The locking bushing styles shall be in the locked position.
- b. Measurements after mounting: Resistance shall be measured as specified in 4.6.2. Resistance shall be measured between the contact arm terminal and terminal 1, and between terminals 1 and 3.
- c. Test condition: C, part 2.
- d. Motion: In each of two mutually perpendicular directions, one perpendicular and the other parallel to the longitudinal axis of the resistor.
- e. Measurement during test: Each resistor shall be monitored to determine momentary discontinuity by a method which shall at least be sensitive enough to monitor or register automatically any momentary discontinuity of 0.1 millisecond or greater duration. A measurement of transient resistance change between the contact arm terminal and terminal 1 shall also be made.
- f. Measurements and examinations after test: Total resistance shall be measured as specified in 4.6.2. The resistance shall also be measured between the contact arm terminal and terminal 1 and between terminals 1 and 3. Resistors shall then be examined for evidence of mechanical damage.

4.6.17 Fungus (see 3.22). Resistors shall be tested in accordance with method 508 of MIL-STD-810. Resistors shall be examined for evidence of mechanical damage.

## 5. PACKAGING

5.1 Packaging. Resistors shall be prepared for delivery in accordance with MIL-R-39032.

## 6. NOTES

(This section contains information of a general or explanatory nature that may be helpful, but is not mandatory.)

6.1 Intended use. Resistors covered by this specification are intended for use in electronic equipment, and are used for matching, balancing, and adjusting circuit variables in computers, telemetering equipment, and other applications.

6.2 Acquisition documents. Acquisition documents should specify the following:

- a. Title, number, and date of this specification.
- b. Title, number, and date of the applicable detail specification, and complete PIN (see 1.2.1 and 3.1).
- c. Mounting hardware (see 3.4.6.1).

## MIL-R-94E

6.3 Qualification. With respect to products requiring qualification awards will be made only for products which are, at the time of award of contract, qualified for inclusion in Qualified Products List QPL-94 whether or not such products have actually been so listed by that date. The attention of the contractors is called to these requirements, and manufacturers are urged to arrange to have the products that they propose to offer to the Federal Government tested for qualification in order that they may be eligible to be awarded contracts or purchase orders for the products covered by this specification. The activity responsible for the Qualified Products List is US Army Laboratory Command; however, information pertaining to qualification of products may be obtained from the Defense Electronics Supply Center (DESC-E), 1507 Wilmington Pike, Dayton, OH 45444.

6.4 Supplementary insulation. Resistors should not be used at potentials to ground greater than a peak voltage of 500 volts, or 200 volts for aircraft equipment, unless supplementary insulation is provided.

6.5 Soldering. Care should be taken in soldering resistors, since all properties of a composition resistors may be seriously affected when soldering irons are applied to terminals for too long a period.

6.6 Hum pickup. Design engineers confronted with the problem of hum pickup by resistors from attached switches in any particular application should specify separate switches at an appropriate distance from the resistors.

6.7 Shaft-locking devices. Suitable locking devices are commercially available which may be readily attached to any standard bushing type resistor covered by this specification. These locking devices permit any degree of torque from normal up to complete locking of the operating shaft of the resistor. The locking bushing type resistor specified herein provides the shaft locking feature without additional equipment.

6.8 Derating. If it is desired to operate these resistors at ambient temperature greater than 70°C, the resistors should be derated in accordance with figure 6.

6.9 Transient change in resistance. It is suggested that when these resistors encounter shock and high frequency vibration forces of the magnitudes enumerated in this specification, that they be used only in applications where a 10-percent variation can be tolerated in the resistance at the contact area.

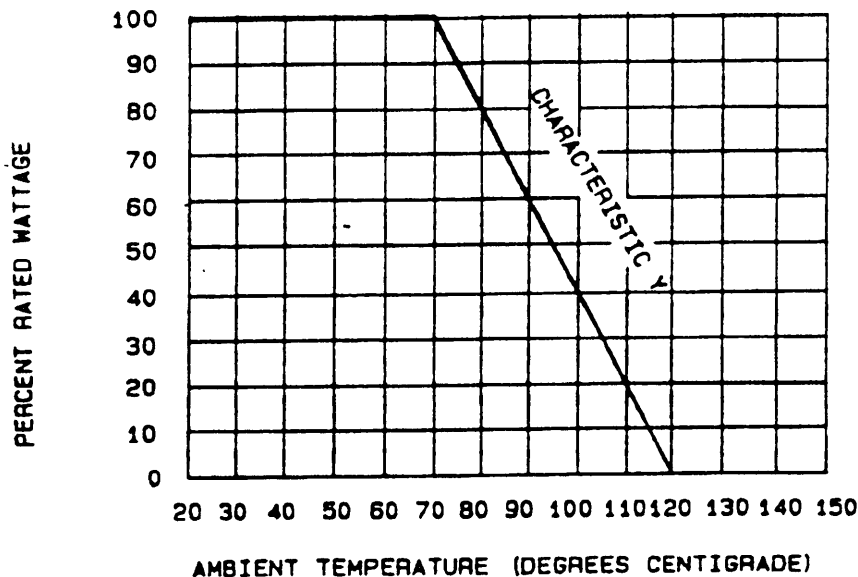
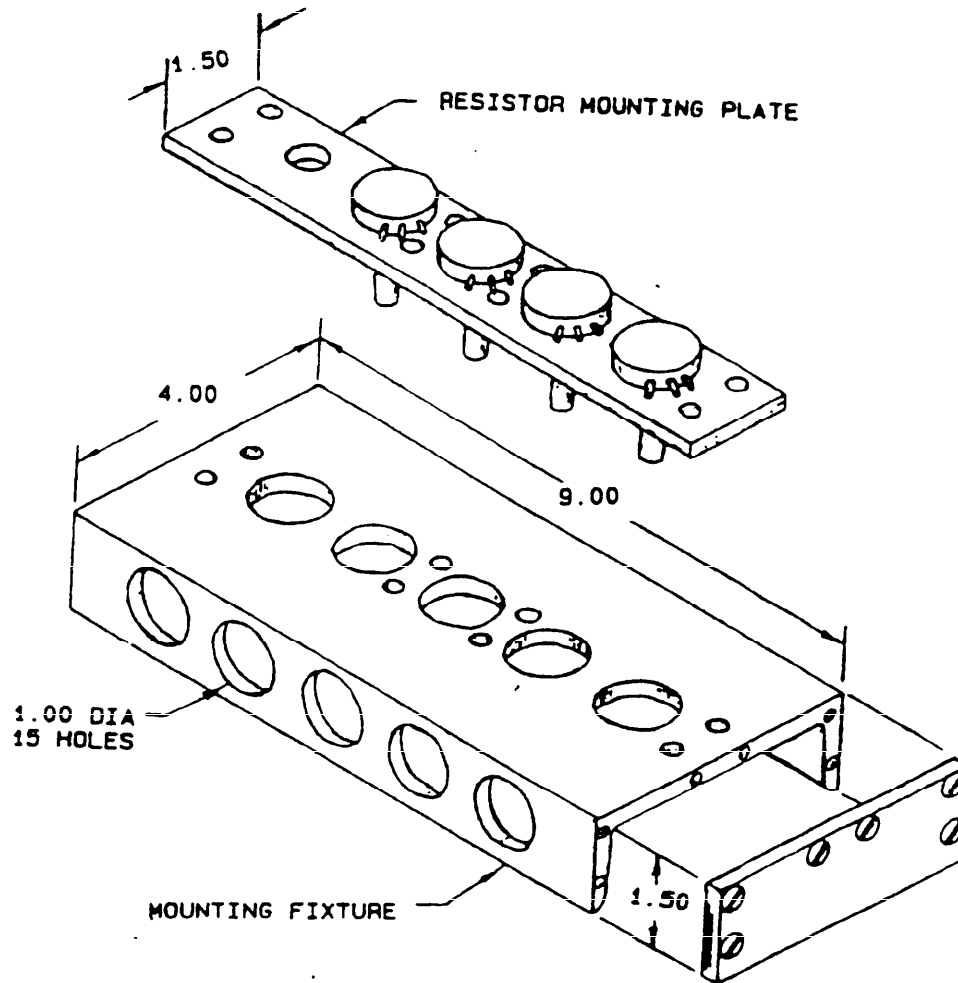

FIGURE 6. Derating curve for continuous duty.



MIL-R-94E



| Inches | mm     |
|--------|--------|
| 1.00   | 25.40  |
| 1.50   | 38.10  |
| 4.00   | 101.60 |
| 9.00   | 228.60 |

NOTES:

1. Dimensions are in inches.
2. Metric equivalents are given for general information only.
3. Tolerance is  $\pm 0.02$  (0.51 mm)

FIGURE 7. Suggested mounting fixture and resistor mounting plate for shock, and high frequency vibration tests.

## MIL-R-94E

- 6.10 Shock and vibration, high frequency. Suggested mounting fixture is shown on figure 7.
- 6.11 Temperature characteristic. The temperature characteristic will change an average of  $\pm 8$  percent due to thermal cycling.
- 6.12 Acceleration. The acceleration test was deleted from this revision because the thermal shock and vibration tests will show up any defects that the acceleration test would have accomplished.
- 6.13 Selection and use information. Equipment designers should refer to MIL-STD-199, "Resistors, Selection and Use of" for a selection of standard resistor types and values for new equipment designs. Application and use information concerning these resistors is also provided in MIL-STD-199.
- 6.14 Supersession data. Slotted shafts, identified by symbol S shall be used for replacement of flatted shafts, identified by symbol F. For military replacement purposes, resistors with resistance characteristics identified by symbols A, C, and E shall be used for replacement of resistors with resistance characteristics identified by symbols B, D, and F. Supersession of styles and other characteristics shall be as specified in table XVIII.
- 6.15 Retinning leads. If retinning (hot solder dip) of the leads is required (see 3.4.4.1).
- 6.16 Subject (key word) listing. Potentiometer
- 6.17 PIN. PIN is a new term encompassing terms previously used in specifications such as part number, type designation, identification number etc. (see 1.2.1).
- 6.18 Changes from the previous issue. Marginal notations are not used in this revision to identify changes with respect to the previous issue due to the extensiveness of the changes.

TABLE XVIII. Styles and characteristics.

| Style and characteristics in MIL-R-94 | Supersedes style and characteristics in MIL-R-94C | Supersedes styles and characteristics in MIL-R-94B   |
|---------------------------------------|---|--|
| RV2Y<br>RV4Y<br>RV5Y<br>RV6Y          | RV2Y<br>RV4Y<br>RV5Y<br>RV6Y                      | RV2 characteristic X and Y<br>RV4 characteristic X and Y<br>RV5 characteristic X and Y<br>RV1 and RV6 characteristic X and Y |

## MIL-R-94E

## APPENDIX

## PROCEDURE FOR QUALIFICATION INSPECTION

## 10. SCOPE

10.1 Scope. This appendix details the procedure for submission of samples, with related data, for qualification inspection of resistors covered by this specification. The procedure for extending qualification of required sample to other resistors covered by this specification is also outlined herein. This appendix is a mandatory part of this specification. The information contained herein is intended for compliance.

20. APPLICABLE DOCUMENTS. This section is not applicable to this document.

TABLE XIX. Samples for qualification inspection.

| Lot     | Number of samples units to be submitted (see 30.1.2) | Total resistance  | Switch | Taper  | Groups (see table IX) and sample units numbers |         |        |          |          |          |          |          |          |
|---------|--|-------------------|--------|--------|--|---------|--------|----------|----------|----------|----------|----------|----------|
|         |  |                   |        |        | I  | II      | III    | IV       | V        | VI       | VII      | VIII     | IX 4/    |
| 1       | 56   | Lowest 1/         | None   | A      | 1 to 6   | 7 to 12 | 1 to 6 | 13 to 18 | 19 to 24 | 25 to 30 | 31 to 36 | 37 to 46 | 47 to 56 |
| 2       | 6  | 10,000 ohms       | None   | C or F | 1 to 6   |         | 1 to 6 |          |          |          |          |          |          |
| 3       | 12   | Critical value 2/ | None   | A      | 1 to 6   |         |        | 1 to 6   | 13 to 18 |          |          |          |          |
| 4<br>3/ | 12   | Critical value 2/ | SPST   | A      | 1 to 6   |         | 1 to 6 |          | 13 to 18 |          |          |          |          |
| 5       | 56   | Highest 1/        | None   | A      | 1 to 6   | 7 to 12 | 1 to 6 | 13 to 18 | 19 to 24 | 25 to 30 | 31 to 36 | 37 to 46 | 47 to 56 |

1/ For which qualification is sought.

2/ See table XXI.

3/ If lot 4 is not submitted, 24 sample units shall be submitted for lot 3. Six of the additional sample units shall be subjected to the tests of group III and the remaining 6 to the tests of group VI.

4/ Manufacturers can provide certification that resistors are fungus free or shall test resistor.

## 30. SUBMISSION

30.1 Sample.

30.1.1 Single type submission. A sample consisting of 56 specimens of each type for which qualification is sought shall be submitted in accordance to table XIX. All specimens shall have .875 inch (22.23 mm) shaft lengths.

## MIL-R-94E

## APPENDIX

30.1.2 Combined type submission. For qualification of either the standard bushing or the locking bushing type resistors, a sample consisting of the number of sample units specified in table XIX shall be submitted in each style and moisture resistance characteristic for which qualification is sought. To receive qualification of locking bushing type resistors when standard bushing type resistors have been submitted, an additional sample of locking bushing type resistors shall be submitted. This sample shall consist of the number of sample units specified in table XX and shall have a resistance value equal to the critical value as specified in table XXI. All sample units shall have .875 inch (22.23 mm) length shafts.

TABLE XX. Samples for qualification inspection of additional locking bushing types.

| Number of sample units in the same style to be submitted (see 30.1.2) | Groups (see table X) and sample units numbers |        |         |
|---|---|--------|---------|
|   | I   | II     | III     |
| 12  | 1 to 12                                       | 1 to 6 | 7 to 12 |

TABLE XXI. Critical resistance value.

| Style | Resistance     |
|-------|----------------|
|       | <u>Megohms</u> |
| RV5   | 0.10           |
| RV6   | 0.25           |
| RV2   | 0.10           |
| RV4   | 0.10           |

## MIL-R-94E

## APPENDIX

TABLE XXII. Extent of qualification.

| Lots passed           |  |
|-----------------------|--|
| 1, 2, 3, 4, 5         | All resistance values between the highest and lowest values submitted, all tapers with or without switches.                |
| 1, 2, 3, 4            | All resistance values between the lowest value submitted and critical value, all tapers with or without a switch.          |
| 1, 2, 3, 5 <u>1</u> / | All resistance values between the highest and lowest values submitted, all tapers without switches.                        |
| 1, 2, 4, 5            | No qualification   |
| 1, 3, 4, 5            | All resistance values between the highest and lowest values submitted, taper A only, with or without switches.             |
| 2, 3, 4, 5            | All resistance values between critical value and highest value submitted, all tapers, with or without switches.            |
| 1, 2, 3 <u>1</u> /    | Lowest value submitted to the critical value, all tapers, without switches.  |
| 1, 2, 4               | No qualification.  |
| 1, 2, 5               | No qualification.  |
| 1, 3, 4               | All resistance values between the lowest value submitted and the critical values, taper A only, with and without a switch. |
| 1, 3, 5 <u>1</u> /    | All resistance values between the highest and lowest values submitted, taper A only, without switches.                     |
| 1, 4, 5               | No qualification.  |

See footnote at end of table.

## MIL-R-94E

## APPENDIX

TABLE XXII. Extent of qualification - Continued.

| Lots passed       |   |
|-------------------|---|
| 2, 3, 4           | No qualification.   |
| 2, 3, 5 <u>1/</u> | All resistance values between the critical value submitted, all tapers, without switches.                         |
| 3, 4, 5           | All resistance values between critical value and highest value submitted, taper A only, with or without a switch. |
| 1, 2              | No qualification.   |
| 1, 3 <u>1/</u>    | All resistance values between lowest value submitted and the critical value, taper A only without switches.       |
| 1, 4              | No qualification.   |
| 1, 5              | No qualification.   |
| 2, 3 or 2, 4      | No qualification.   |
| 2, 5              | No qualification.   |
| 3, 4              | No qualification.   |
| 3, 5              | All resistance values between the critical value and the highest value submitted, taper A only, without switches. |
| 1                 | No qualification.   |
| 2, 3, or 4        | No qualification.   |
| 5                 | No qualification.   |

1/ If only the switch fails, this statement applies; if resistor fails in lot 4, no qualification shall be granted.

30.2 Test data. Each submission shall be accompanied by test data covering the nondestructive tests listed in table IX or X which have been performed on the submitted sample units. The performance of the destructive tests by the supplier on a duplicate set of sample units is encouraged, although is not required. All test data shall be submitted in duplicate. Qualification of the switch in any style will qualify switches in all other styles. Approval of resistors with slotted shafts shall be the basis for approval of flatted shafts. Approval of flatted shafts will be the basis for approval of slotted shafts.

30.3 Certificate of material. When submitting samples for qualification, the supplier shall submit certification, in duplicate, of the materials used in the components and that they are in accordance with the applicable specification requirements.

30.4 Description of items. The supplier shall submit a detailed description of the resistors being submitted for test, including a description of case material, type of element and contacts, and method of fastening of terminals to base and element.

#### 40. EXTENT OF QUALIFICATION

40.1 Single type submission. Qualification shall be for the type submitted.

## MIL-R-94E

## APPENDIX

40.2 Combined type submission. Qualification within a style and characteristic shall be shown in table XXII. Qualification of resistors with standard (N) type bushings shall qualify resistors with sealed (S) type bushings. Conversely, qualification of resistors with sealed (S) type bushing shall qualify resistors with standard (N) type bushing. Qualification of resistors with locking (L) type bushing shall qualify resistors with sealed (T) type bushings. Conversely, qualification resistors with sealed (T) type bushings shall qualify resistors with locking (L) type bushings.

## CONCLUDING MATERIAL

## Custodians:

Army: ER  
Navy: EC  
Air Force: 85

## Review activities:

Army: AR, MI  
Navy: AS, OS  
Air Force: 17, 80, 99

## User activities:

Army: AT, AV, ME  
Navy: MC  
Air Force: 19

## Preparing activity:

Army: ER

## Agent:

DLA: ES

(Project 5905-1248)