

INCH-POUND

MIL-PRF-6164G  
 16 October 2012  
 SUPERSEDING  
 MIL-PRF-6164F  
 10 October 1998

## PERFORMANCE SPECIFICATION

## VALVE; AIRCRAFT, PNEUMATIC, HIGH-PRESSURE CHARGING

This specification is approved for use by all Departments and Agencies of the Department of Defense.

## 1. SCOPE

1.1 Scope. This specification covers several types of high-pressure pneumatic valves for aircraft use.

1.2 Classification. High-pressure air valves should be supplied in the following Government designations, types, and classes, as specified (see 6.2).

TABLE I. Valve classification.

| Dash No | Type of valve |                               | Class of valve |  |
|---------|---------------|-------------------------------|----------------|--|
|         | type          | maximum rated pressure (psig) | class          | Fluid compatibility                          |
| -1      | A             | 5000                          | 1              | MIL-PRF-5606, MIL-PRF-83282<br>MIL-PRF-87257 |
| -3      | B             | 5000(special)                 | 1              | MIL-PRF-5606, MIL-PRF-83282<br>MIL-PRF-87257 |
| -4      | A             | 5000                          | 2              | Jet Fuel, Synthetic Oil, hydraulic fluid     |
| -5      | A             | 5000                          | 3              | SAE-AS1241, phosphate ester hydraulic fluid  |
| -12     | C             | 8000                          | 1              | MIL-PRF-5606, MIL-PRF-83282<br>MIL-PRF-87257 |

Comments, suggestions, or questions on this document should be addressed to Oklahoma City Air Logistics Center/ENSDAA, 3001 Staff Drive, Tinker AFB, OK. 73145 or emailed to [af71@tinker.af.mil](mailto:af71@tinker.af.mil). Since contact information can change, you may want to verify the currency of this address information using the ASSIST Online database at <https://assist.dla.mil>.

## MIL-PRF-6164G

1.3 Part or identifying number (PIN). The PIN to be used for valves acquired to this specification are created as follows:

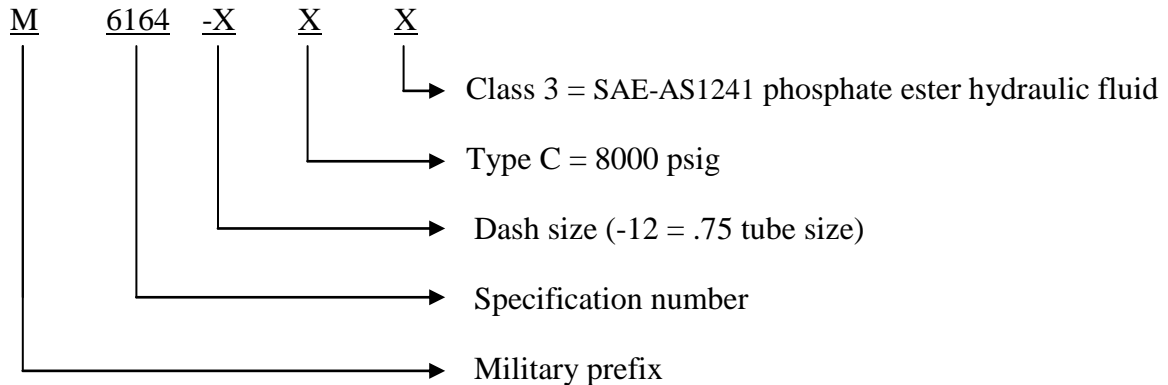

## 2. APPLICABLE DOCUMENTS

2.1 General. The documents listed in this section are specified in sections 3, 4, or 5 of this specification. This section does not include documents cited in other sections of this specification or recommended for additional information or as examples. While every effort has been made to ensure the completeness of these lists, document users are cautioned that they must meet all specified requirements of the documents cited in sections 3, 4, or 5 of this specification, whether or not they are listed.

### 2.2 Government documents.

2.2.1 Specifications and standards. The following specifications and standards form a part of this document to the extent specified herein. Unless otherwise specified, the issues of these documents are those cited in the solicitation or contract.

## INTERNATIONAL STANDARDIZATION AGREEMENTS

AIR-STD-25/35A(2) - Aircraft Gaseous Air/Nitrogen Replenishment Connections

## FEDERAL SPECIFICATIONS

BB-A-1034 - Compressed Air, Breathing  
BB-H-1168 - Helium, Technical

## COMMERCIAL ITEM DESCRIPTIONS

A-A-59503 - Nitrogen, Technical

## DEPARTMENT OF DEFENSE SPECIFICATIONS

MIL-PRF-5606 - Hydraulic Fluid, Petroleum Base; Aircraft, Missile and Ordnance

## MIL-PRF-6164G

- MIL-PRF-83282 - Hydraulic Fluid, Fire Resistant, Synthetic Hydrocarbon Base, Metric, NATO Code Number H-537
- MIL-PRF-87257 - Hydraulic Fluid, Fire Resistant; Low Temperature, Synthetic Hydrocarbon Base, Aircraft and Missile

## DEPARTMENT OF DEFENSE STANDARDS

- AND10071 - Boss and Installations-Air Connection (AN6287)
- MS20813 - Cap, High-Pressure Air Valve
- MS33651 - Boss and Installations-Air Connection

(Copies of these documents are available online at <https://assist.dla.mil/> or from the Standardization Document Order Desk, 700 Robbins Avenue, Building 4D, Philadelphia, PA 19111-5094.)

2.3 Non-government publications. The following documents form a part of this document to the extent specified herein. Unless otherwise specified, the issues of these documents are those cited in the solicitation or contract.

## AEROSPACE INDUSTRIES ASSOCIATION of AMERICA, INC. (AIA)

- NAS1611 - Packing, Ethylene Propylene Preformed O-Ring Phosphate Ester Resistant (-65°F to 250/300°F) (DoD adopted)

(AIA documents may be obtained at [www.aia-aerospace.org/](http://www.aia-aerospace.org/) or from Aerospace Industries Association, 1000 Wilson Boulevard, Suite 1700, Arlington, VA 22209-3928.)

## AMERICAN SOCIETY OF MECHANICAL ENGINEERS (ASME)

- ASME-B46.1 - Surface Texture, (Surface Roughness, Waviness, and Lay)

(ASME documents may be obtained at <http://www.asme.org/> or addressed to American Society of Mechanical Engineers, United Engineering Center, Three Park Avenue New York, NY 1006-5990).

## AMERICAN SOCIETY FOR TESTING AND MATERIALS (ASTM)

- ASTM-B117 - Salt Spray (Fog) Apparatus, Operating (DoD adopted)

(ASTM documents may be obtained at [www.astm.org](http://www.astm.org) or addressed to the American Society for Testing and Material, 100 Barr Harbor Drive, P.O. West Conshohocken, PA 19428-2959.)

## SOCIETY OF AUTOMOTIVE ENGINEERS (SAE)

- SAE-AS1241 - Fire Resistant Phosphate Ester Hydraulic Fluid for Aircraft

## MIL-PRF-6164G

|                    |   |   |
|--------------------|---|---|
| SAE-AMS2610        | - | Pressure Testing, Gaseous Media Pressure as Specified   |
| SAE-AS5202         | - | Port or Fitting End, Internal Straight Thread (DoD adopted)   |
| SAE-AS8879         | - | Screw Threads – UNJ Profile, Inch Controlled Radius<br>Root with Increased Minor Diameter   |
| SAE-AMS-P-83461/1- |   | Packing, Preformed, Petroleum Hydraulic Fluid Resistant,<br>Improved Performance at 275°F (135°C) Sizes and<br>Tolerances (DoD adopted) |
| SAE-AMS-R-83485/1- |   | Rubber, Fluorocarbon Elastomer, Improved Performance<br>at Low Temperatures, O-Rings, Sizes and Tolerances<br>(DoD adopted)             |

(SAE documents may be obtained at <http://www.sae.org/> or addressed to Society of Automotive Engineering, Inc., 400 Commonwealth Drive, Warrendale, PA 15096-0001.)

2.4 Order of precedence. Unless otherwise noted herein or in the contract, in the event of a conflict between the text of this document and the references cited herein, the text of this document takes precedence. Nothing in this document, however, supersedes applicable laws and regulations unless a specific exemption has been obtained.

### 3. REQUIREMENTS

3.1 First article. When specified (see 6.2), a sample shall be subjected to first article inspection in accordance with 4.2.

3.2 Recycled, recovered, or environmentally preferable materials. Recycled, recovered, or environmentally preferable materials should be used to the maximum extent possible, provided that the material meets or exceeds the operational and maintenance requirements, and promotes economically advantageous life cycle costs.

3.3 Materials. All materials shall be corrosion resistant or treated to resist corrosion due to electrolytic decomposition, salt air, and any other atmospheric condition that may be encountered during operational use or storage. The use of toxic chemicals, hazardous substances, or ozone depleting chemicals shall be avoided, whenever feasible.

#### 3.4 Interface.

3.4.1 Dimensions. The dimensions of the M6164-2 through M6164-5 and M6164-12 valves shall conform to figure 1.

3.4.2 Bosses. The M6164-2 through M6164-5 valves shall install into SAE-AS5202 or MS33651 boss. The M6164-12 valve shall install into a boss (see MS33651 for guidance), but the selected boss must be rated for a maximum pressure of 8,000 psig.

#### 3.5 Performance.

3.5.1 Cap. The valve shall have a cap in accordance with MS20813.

## MIL-PRF-6164G

3.5.2 Nut. The valve shall be opened and closed by a nut located on and attached to the valve body (see figure 1). With the valve installed in the boss, the nut shall be rotated clockwise (CW) to close the valve and counter clockwise (CCW) to open the valve. The valve shall go from fully closed to the fully opened position in 1 to 2 ¼ turns of the nut. The nut shall stop rotating in the fully closed and opened positions.

3.5.3 Leakage. There shall be no leakage when the valve is subjected to its maximum rated pressure (see 1.2).

3.5.4 Cycling.

3.5.4.1 M6164-2 through M6164-5. The valve shall withstand 100 cycles of opening and closing to 55 ±5 inch pounds torque at pressure to 5000 psi and temperature -65°F to + 275°F (see 6.6).

3.5.4.2 M6164-12. The valve shall withstand 500 cycles of opening and closing to 55 ±5 inch pounds torque (see 6.6) at pressures to 8,000 psig and temperatures of -65° to 275°F.

3.5.5 Burst pressure. There shall be no evidence of failure or leakage when the valve is pressurized to 2.5 times its maximum rated pressure.

3.5.6 M6164-3 and M6164-12 helium leakage. There shall be no leakage when the valve is pressurized between 16 and 18 psig with helium.

3.5.7 Flow rate. The gas flow rate through the valve at its maximum rated pressure shall be a minimum of 80 liters per minute (LPM).

3.5.8 Audible pressure warning feature. The valve shall have an audible pressure warning feature which creates an audible warning when the valve body is loosened from the boss while pressurized between 50 psig and the maximum rated pressure of the valve (see 6.7).

3.6 Item identification. The valves and fittings shall be marked with the following information (see 6.2).

- a. Manufacturer's identification
- b. Manufacturer's CAGE code
- c. Manufacturer's part number (PN)
- d. Part or Identification Number (PIN) (see 6.10)
- e. Additional identification information if available (see 6.2)

3.7 Interchangeability. All parts having the same manufacturer's part number shall be functionally and dimensionally interchangeable.

#### 4. VERIFICATION

## MIL-PRF-6164G

4.1 Classification of inspections. The inspection requirements specified herein are classified as follows:

- a. First article inspection (see 4.2).
- b. Conformance inspection (see 4.3).

4.2 First article inspection. First article inspection shall be performed on ten valves of each class and shall consist of installing valves as specified in 4.4.3, pre-torquing them as specified in 4.4.4, and then subjecting them to all the tests in 4.6 except 4.6.2.2. The test in 4.6.8 is required when specified in the acquisition document (see 6.2). All valves subjected to first article inspection shall not be delivered (see 6.9).

4.3 Conformance inspection. Conformance inspection shall consist of the following tests:

- a. Examination (see 4.6.1)
- b. Leakage (see 4.6.2.2)

4.4 Test conditions.

4.4.1 Temperature and pressure. Unless otherwise specified in the individual test description, tests shall be conducted at ambient temperature and pressure.

4.4.2 Test medium. Unless otherwise specified in the individual test description, the gas used for testing shall be compressed air conforming to BB-A-1034, Grade B or nitrogen conforming to A-A-59503, type I, Class I, Grade B.

4.4.3 Valve installation.

4.4.3.1 O-ring. SAE-AMS-P-83461/1 O-ring shall be used. The valve O-ring shall be lubricated (see 6.4) before installing the valve into the boss.

4.4.3.2 M6164-2 through M6164-5 valves. The M6164-2 through M6164-5 shall have the cap removed before installing, finger tight, into SAE-AS5202 boss. MS33651 may be used for installation guidance. The valve body shall be torqued to  $120 \pm 5$  inch-pounds. The nut shall be opened to a free swiveling condition (see 6.8).

4.4.3.3 M6164-12 valve. The M6164-12 valve shall have the cap removed before installing into SAE-AS5202 boss rated for 8,000 psig applications. The MS33651 boss may be used for installation guidance but is only rated for a maximum 5000 psig. The valve body shall be torqued to  $120 \pm 5$  inch-pounds. The nut shall be opened to a free swiveling condition (see 6.8).

4.4.4 First article pre-torque. All first article valves shall have the nut pre-torqued to  $120 \pm 5$  inch-pounds two successive times before beginning tests in 4.6.3. The nut shall be opened to a free swiveling condition (see 6.8) after each torque application and remain attached to the valve body. This pre-torque does not apply to valves subjected to conformance inspection.

## MIL-PRF-6164G

4.5 Requirements cross-reference matrix. Table II provides a cross-reference matrix of the section 3 requirements tested or verified in the paragraphs below.

TABLE II. Requirements cross-reference matrix

| Requirement | Verification | Requirement | Verification |
|-------------|--------------|-------------|--------------|
| 3.1         | 4.2          | 3.5.4.2     | 4.6.3.2      |
| 3.3         | 4.6.1, 4.6.8 | 3.5.5       | 4.6.4        |
| 3.4.1       | 4.6.1        | 3.5.6       | 4.6.5        |
| 3.4.2       | 4.6.1        | 3.5.7       | 4.6.6        |
| 3.5.1       | 4.6.1        | 3.5.8       | 4.6.7        |
| 3.5.2       | 4.6.1, 4.6.9 | 3.6         | 4.6.1        |
| 3.5.3       | 4.6.2        | 3.7         | 4.6.1        |
| 3.5.4.1     | 4.6.3.1      |             |              |

4.6 Tests.

4.6.1 Examination. The valve shall be examined for compliance with the requirements for materials, dimensions, cap, nut, valve core, markings, and interchangeability.

4.6.2 Leakage.

4.6.2.1 First article leakage test. The valve shall be closed by rotating the nut CW to a torque of  $55 \pm 5$  inch-pounds. With the valve immersed in water, the maximum rated pressure shall be applied for 1 minute. The pressure shall then be reduced to 0 psig, increased to 85 psig for 1 minute, and then reduced to 0 psig. There shall be no leakage. Leakage is defined as gas bubbles forming or rising from the valve or the boss during the last 55 seconds of each 1 minute period of pressure application (see 6.5).

4.6.2.2 Conformance leakage test. The valve shall be cycled once by opening and closing the valve to  $55 \pm 5$  inch-pounds (see 6.6) then subjected to the leakage test in 4.6.2.1.

4.6.3 Cycling.

4.6.3.1 M6164-2 through M6164-5. The valve shall be subjected to 100 cycles of opening and closing to  $55 \pm 5$  inch-pounds (see 6.6). After 100 cycles, the valve shall be subjected to the leakage test in 4.6.2.1.

4.6.3.2 M6164-12. The valve shall be subjected to 500 cycles of testing divided into five 100 cycle sequences of opening and closing to  $55 \pm 5$  inch-pounds (see 6.6). The first 100 cycle sequence is performed with the valve pressurized to 8,000 psig and released between cycles. The second 100 cycle sequence is conducted after the valve is exposed to  $-65^{\circ}\text{F}$  for 1 hour at ambient pressure and then allowed to return to ambient temperature. The third and fifth 100 cycle sequence shall be performed at ambient temperature and pressure. The fourth 100 cycle sequence shall be performed after the test valve is exposed to  $275^{\circ}\text{F}$  for 1 hour at ambient pressure and

## MIL-PRF-6164G

then allowed to return to ambient temperature. The valve shall be subjected to the leakage test in 4.6.2.1 after each of the five 100 cycle sequences.

4.6.4 Burst pressure. The valve shall be installed in a boss as specified in 4.4.3. Hydraulic or air pressure equal to 2.5 times the valves maximum rated pressure shall be applied for at least 15 seconds. There shall be no evidence of failure or leakage.

4.6.5 M6164-3 and M6164-12 helium leak. The valve shall be subjected to the leakage test specified in SAE-AMS-2610 while immersed in water and pressurized between 16 to 18 psig using helium conforming to BB-H-1168, Grade B. There shall be no leakage.

4.6.6 Flow rate. With the valve fully opened, the maximum rated pressure shall be applied to the valve stem (see figure 1). The minimum flow through the body of the valve shall be 80 LPM.

4.6.7 Audible pressure warning feature. The valve shall be installed in a boss as specified in 4.4.3. With the valve and boss pressurized between 50 psig and maximum rated pressure, the valve body shall be loosened from the boss. The air escaping through the feature shall create an audible sound.

4.6.8 Salt fog. If specified (see 6.2), the valve, with inlet and outlet plugged, shall be subjected to the salt fog test in accordance with ASTM-B117 for 50 hours. There shall be no damage to the valve. The valve shall then be subjected to the leakage test in 4.6.2.1.

4.6.9 Nut travel. The nut shall be turned CW to the closed position and then CCW to the fully open position. The rotation of the nut between closed and opened positions shall be between 1 to 2 ¼ turns. The nut rotation shall stop at the closed and fully open positions.

## 5. PACKAGING

5.1 Packaging. For acquisition purposes, the packaging requirements shall be as specified in the contract or order (see 6.2). When packaging of materiel is to be performed by DoD or in-house contractor personnel, these personnel need to contact the responsible packaging activity to ascertain packaging requirements. Packaging requirements are maintained by the Inventory Control Point's packaging activities within the Military Service or Defense Agency, or within the military service's system commands. Packaging data retrieval is available from the managing Military Department's or Defense Agency's automated packaging files, CD-ROM products, or by contacting the responsible packaging activity.

## 6. NOTES

(This section contains information of a general or explanatory nature that may be helpful, but is not mandatory.)

6.1 Intended use. The high pressure air valves covered by this specification are intended for use in gas-charged units such as shock-absorber struts, hydraulic-pressure accumulators, surge cylinders, and air bottles which may be in JSSG 2009 Pneumatic Power Systems, High Pressure



## MIL-PRF-6164G

(pneumatic), SAE-AS5440 Hydraulic Systems, Aircraft, Design and Installation Requirements For (hydraulic), and similar systems. The M6164-3 is intended for use where a more extreme definition of leak-free is required to be verified. The M6164-12 is intended for use where higher pressure is used or increased durability is needed.

6.2 Acquisition requirements. Acquisition documents should specify the following:

- a. Title, number, and date of this specification.
- b. Classification (see 1.2).
- c. Issue of ASSIST to be cited in solicitation, and if required, the specific issue of individual documents referenced (see 2.2.1 and 2.3).
- d. When first article is required (see 3.1).
- e. Additional item identification required, if any (see 3.6).
- f. Whether the salt fog is waived and material certification is acceptable (see 4.6.8).
- g. Packaging requirements (see 5.1).

6.3 Interchangeability. The high pressure air valve classes in this specification are not interchangeable with each other. A higher pressure valve may be substituted for a lower, but not the reverse. If a substitution is made it should be noted that the charging, discharging and removal requirements differ.

6.4 Lubrication. SAE-AMS-G-4343 grease and MIL-PRF-6083 hydraulic fluid are proven o-ring lubricants.

6.5 Leakage test. A light has been used during the leakage tests to aid in detection of gas bubbles.

6.6 One cycle of opening and closing. One cycle of opening and closing is defined as rotating the nut CCW until it swivels freely (open) and then rotating the nut CW to the specified torque (closed).

6.7 Audible pressure warning feature. The audible pressure warning feature is to warn a user not to loosen the valve body from the boss while under pressure. If not warned, the user can continue to loosen the valve and the valve could become a projectile injuring the user. A proven audible pressure warning feature is a slot cut into the valve body threads (.500-20 UNF-3A) which allows air to escape from the threads when loosened.

6.8 Free swiveling. The free swiveling condition is when the nut is between open and closed positions and rotates freely.

6.9 First article valves. The first article inspection depletes the usable life of the valve. These valves should be used only for inspection and reference applications.

6.10 Supersession data. For supersession data see figure 1.

## MIL-PRF-6164G

### 6.11 Subject term (key word) listing.

Air bottles  
Accumulators  
Surge cylinders

6.12 International standardization agreement implementation. This specification implements ASCC Air STD-25/35A(2) Aircraft Gaseous Air/Nitrogen Replenishment Connections. When amendment, revision, or cancellation of this specification is proposed, the preparing activity must coordinate the action with the U.S. National Point of Contact for the international standardization agreement, as identified in the ASSIST database at <https://assist.dla.mil/>.

6.13 Changes from previous issue. Marginal notations are not used in this revision to identify changes with respect to the previous issue due to the extent of the changes.

MIL-PRF-6164G

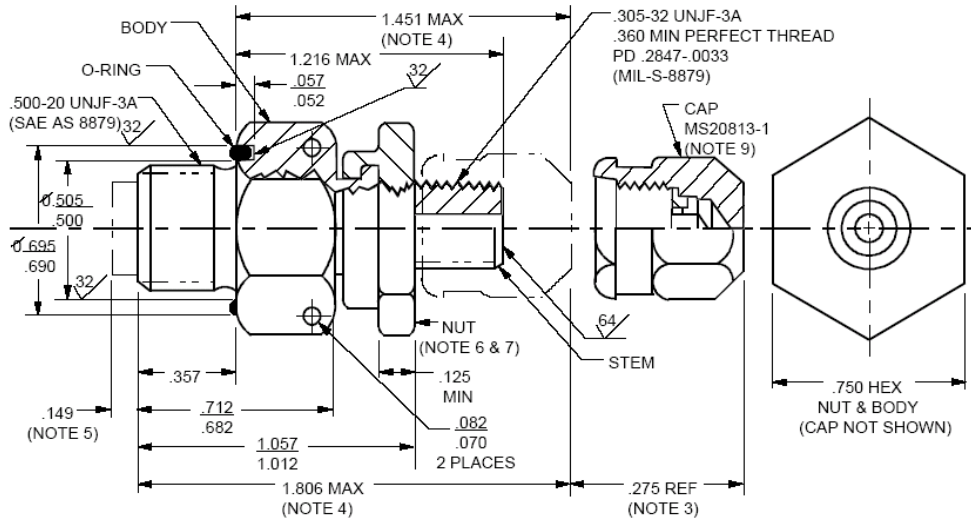

| PIN      | TYPE           | O-RING TYPE  | CLASS FLUID COMPATIBILITY                                  | SUPERSEDING |
|----------|----------------|--------------|--|-------------|
| M6164-2  | 5000           | M83461/A-015 | MIL-PRF-83282, MIL-H-5606, MIL-PRF-87257 HYDRAULIC FLUID   | MS28889-2   |
| M6164-3  | 5000 (SPECIAL) | M83461/A-015 | MIL-PRF-83282, MIL-H-5606 MIL-PRF-87257 HYDRAULIC FLUID    | -           |
| M6164-4  | 5000           | M83485/A-015 | FUEL, SYNTHETIC OIL, & SOME HYDRAULIC FLUID                | -           |
| M6164-5  | 5000           | NAS1611-015  | SAE AS 1241, "SKYDROL TM" PHOSPHATE ESTER; HYDRAULIC FLUID | -           |
| M6164-12 | 8000           | M83461/A-015 | MIL-PRF-83282, MIL-H-5606 MIL-PRF-87257 HYDRAULIC FLUID    | -           |

- NOTES:
1. DIMENSIONS IN INCHES, UNLESS OTHERWISE SPECIFIED
  2. TOLERANCES; UNLESS OTHERWISE SPECIFIED: DECIMALS  $\pm .005$   
ANGLES  $\pm .5^\circ$
  3. CLEARANCE REQUIRED TO REMOVE CAP.
  4. MAXIMUM DIMENSION WITH CAP INSTALLED.
  5. CLEARANCE REQUIRED TO FULLY OPEN VALVE.
  6. THE NUT REQUIRES 1 TO 2 1/4 TURNS TO FULLY OPEN THE VALVE.
  7. NUT SHALL SWIVEL FREELY WHEN SWAGED ON BODY
  8. ALL VALVES FURNISHED WITH MS20813-1 CAP.
  9. FIGURE NOT TO SCALE
  10. UNLESS OTHERWISE SPECIFIED, MAXIMUM ROUGHNESS SHALL BE  $125\mu$  IN ACCORDANCE WITH ASME B46.1.

FIGURE 1. M6164 valve.

MIL-PRF-6164G

Custodians:

Air Force – 71  
Army – AV  
DLA – CC  
Navy – AS

Preparing Activity:

Air Force – 71

(Project 4820-2009-028)

Review Activities:

Air Force – 99  
Navy - SA

NOTE: The activities listed above were interested in this document as of the date of this document. Since organizations and responsibilities can change, you should verify the currency of the information above using the ASSIST database at <https://assist.dla.mil/>.