

INCH-POUND

MIL-PRF-5350G

4 May 2009

SUPERSEDING

MIL-PRF-5350F

28 February 1998

PERFORMANCE SPECIFICATION

TRANSMITTER, SYNCHRO OPERATED, AIRCRAFT, GENERAL SPECIFICATION FOR

This specification is approved for use by all Departments and Agencies of the Department of Defense.

1. SCOPE

1.1 Scope. This general specification covers aircraft synchro transmitters (see 6.3.2).

2. APPLICABLE DOCUMENTS

2.1 General. The documents listed in this section are cited in sections 3, 4, or 5 of this specification. This section does not include documents cited in other sections of this specification or recommended for additional information or as examples. While every effort has been made to ensure the completeness of this list, document users are cautioned that they must meet all specified requirements documents cited in sections 3, 4, or 5 of this specification, whether or not they are listed.

2.2 Government documents.

2.2.1 Specifications and standards. The following specifications and standards form a part of this document to the extent specified herein. Unless otherwise specified, the issues of these documents are those cited in the solicitation or contract.

Comments, suggestions, or questions on this document should be addressed to: Oklahoma City Air Logistics Center/ENSDAA, 3001 Staff Drive, Tinker AFB, OK. 73145-3036 or emailed to af71@tinker.af.mil. Since contact information can change, you may want to verify the currency of this address information using ASSIST Online database at <http://assist.daps.dla.mil>.

MIL-PRF-5350G

DEPARTMENT OF DEFENSE SPECIFICATIONS

MIL-I-7057 - Indicators, Synchro, Aircraft, General Specification for

DEPARTMENT OF DEFENSE STANDARDS

MIL-STD-461 - Requirements for the Control of Electromagnetic Interference Characteristics of Subsystems and Equipment

MIL-STD-1651 - Insert Arrangements for MIL-C-5015, MIL-C-22992 (Classes C, J, and R), and MIL-C-83723 (Series II) Electrical Connectors

MS3102 - Connector, Receptacle, Electric, Box Mounting, Solder Contacts, AN Type

(Copies of these documents are available online at <http://assist.daps.dla.mil/quicksearch/> or from the Standardization Document Order Desk, 700 Robbins Avenue, Building 4D, Philadelphia, PA 19111-5094.)

2.3. Non-Government publications. The following documents form a part of this document to the extent specified herein. Unless otherwise specified, the issues of these documents are those cited in the solicitation or contract.

AMERICAN SOCIETY FOR QUALITY (ASQ)

ANSI/ASQ Z1.4 - Sampling Procedures and Tables for Inspection by Attributes

(ASQ documents may be obtained at <http://asq.org> or addressed to the American Society for Quality P.O. Box 3005 Milwaukee, WI 53201-3005 or 600 North Plankinton Avenue, Milwaukee, Wisconsin, 53203, USA)

AMERICAN SOCIETY FOR TESTING AND MATERIALS (ASTM)

ASTM B117 - Salt Spray (Fog) Apparatus, Operating

(ASTM documents may be obtained at www.astm.org or addressed to the American Society for Testing and Material, 100 Barr Harbor Drive, West Conshohocken, PA 19428-2959.)

RADIO TECHNICAL COMMISSION FOR AERONAUTICS (RTCA)

RTCA/DO-160 - Environmental Conditions and Test Procedures for Airborne Equipment

MIL-PRF-5350G

(RTCA documents may be obtained at www.rtca.org or addressed to RTCA Inc., 1828 L Street, NW, Suite 805, Washington, DC 20036.)

SOCIETY OF AUTOMOTIVE ENGINEERS (SAE)

SAE AS20708 - Synchron, General Specification For

(SAE documents may be obtained at <http://www.sae.org> or from Society of Automotive Engineers, Inc., 400 Commonwealth Drive, Warrendale PA 15096.)

2.4 Order of precedence. Unless otherwise noted herein or in the contract, in the event of a conflict between the text of this document and the references cited herein, the text of this document takes precedence. Nothing in this document, however, supersedes applicable laws and regulations unless a specific exemption has been obtained.

3. REQUIREMENTS

3.1 Associated specifications. The individual item requirements shall be as specified in the associated specification and herein (see 6.2). In the event of any conflict between the requirements of this specification and the associated specification, the latter shall govern.

3.2 First article or qualification. The requirement for first article or qualification shall be imposed by the associated specification (see 4.2, 4.3, 6.2, and 6.4).

3.3 Recycled, recovered, or environmentally preferable materials. Recycled, recovered, or environmentally preferable materials should be used to the maximum extent possible, provided that the material meets or exceeds the operational and maintenance requirements, and promotes economically advantageous life cycle costs.

3.4 Materials. Materials shall produce no toxic, corrosive, or deleterious fumes and shall be resistant to corrosion due to electrolytic decomposition, fungus, fuels, salt fog, and any other atmospheric condition that may be encountered during operational use or storage. Nonmagnetic materials shall be used except where magnetic materials are essential.

3.5 Interface.

3.5.1 General. Transmitters conforming to this specification shall operate with indicators conforming to MIL-I-7057.

3.5.2 Adjustments. No special tools shall be required to adjust the transmitter. Hermetically sealed cases (see 6.3.1) shall have a means of adjustment accessible from the exterior of the case. It shall provide a range of at least 14° of scale adjustment.

3.5.3 Electrical connectors. The transmitter electrical connector shall be as specified in the acquisition document (see 6.2). If not so specified, the connector shall be in accordance

MIL-PRF-5350G

with figure 1, 14S-2P.

3.5.4 External wiring. External wiring between the transmitter and indicator shall be as shown on figure 2 or 3.

3.5.5 Power supply. The transmitter shall operate with a supply voltage between 22 and 30Vac at a frequency between 320 and 400Hz.

3.5.6 Electromagnetic interference and compatibility. The transmitter shall neither cause nor be susceptible to electromagnetic interference.

3.6 Performance.

3.6.1 Case distortion. The operation of the transmitter shall be unaffected by case distortion (see 6.3.3).

3.6.2 Reliability. The reliability of the transmitter shall be as specified in the acquisition document.

3.6.3 Operation. Each transmitter shall be capable of operating up to two indicators without a change in performance.

3.6.4 Dielectric strength. The transmitter shall withstand a potential of 500Vac, 60Hz for unsealed cases and 250Vac, 60Hz for sealed cases applied for 5 seconds between each pin of the electrical connector and the transmitter case.

3.6.5 Seasoning. The transmitter shall meet the scale error requirements after experiencing 10,000 deflection cycles (see 6.3.4).

3.6.6 Endurance. The transmitter shall meet the scale error requirement after experiencing 60,000 deflection cycles (see 6.3.4).

3.6.7 Shock. The transmitter shall withstand a 20g shock with a duration of 11 milliseconds.

3.6.8 Acceleration. The transmitter shall withstand acceleration as specified in the acquisition document.

3.6.9 Humidity. The transmitter shall withstand humidity of 95 percent.

3.6.10 Overscale operation. The transmitter shall withstand an input equivalent to 150% of full scale indication for 10 minutes.

3.6.11 High temperature (non-operational; direct engine-mounted transmitters only). The transmitter shall withstand a temperature of $450^{\circ} \pm 18^{\circ}\text{F}$ for 80 hours.

MIL-PRF-5350G

3.6.12 Torque. The transmitter shall develop a torque in the indicator of no less than 2,000 milligram millimeters per degree of angular displacement from synchronous operation in the range of -20° to 20° of angular displacement.

3.6.13 Sealing (hermetically sealed transmitters only). The case leakage of the transmitter shall be no greater than 0.10 micron cubic foot per hour when the filling medium is nitrogen and helium, and no greater than 1.0 micron cubic foot per hour when the medium is 100% helium.

3.6.14 Scale error. The transmitter shall have a scale error as required in the acquisition document.

3.6.15 Friction error. The transmitter shall have a friction error as required in the acquisition document.

3.6.16 Electrical zero. With R2 connected to S2, and 26Vac, 400Hz electrical power applied to R1 and R2, the transmitter shall meet the following requirements:

- a. The voltage between S1 and S3 (S3S1) shall be at minimum, shall be in phase with rotor voltage E (R2R1), and shall remain approximately in phase as the rotor is turned counterclockwise through an angle not exceeding 180° from electrical zero.
- b. The voltage between R1 and S3 shall be at a minimum null and shall reach the minimum when the rotor is turned clockwise 30° from electrical zero.
- c. Clockwise rotation of the rotor, not exceeding 30° from electrical zero, shall cause an increase in voltage between S3 and S2 and a decrease in voltage between S2 and S1.

3.6.17 Damping. The damping of the transmitter shall be as required in the acquisition document.

3.6.18 Electrical characteristics.

3.6.18.1 Open secondary. The current drawn by one self-synchronous motor shall not exceed 240 milliamperes with the secondaries (stator) open-circuited.

3.6.18.2 Power input. The transmitter power consumption shall not exceed 6.24 Volt-Amperes.

3.6.18.3 Secondary voltage. The maximum open-circuit voltage measured between any two secondary leads shall be 11.8 ± 0.3 Vac. The variation between the three maximum secondary voltages on any one synchro shall not exceed 0.2Vac.

3.6.18.4 Synchro type. The transmitter shall have electrical characteristics compatible with

MIL-PRF-5350G

those defined in AS20708, with the exception of electrical zero.

3.7 Item identification. Item identification shall be as required in the acquisition document (see 6.2).

3.8 Interchangeable parts. All parts having the same manufacturer's part number shall be functionally and dimensionally interchangeable.

3.9 Environmental conditions. The transmitter shall withstand the following environmental conditions.

3.9.1 Aircraft attitude. The transmitter shall meet performance requirements in both the horizontal and vertical position.

3.9.2 Temperature range:

a. Operating:

-67° to 250° ± 3°F

Remote mounted transmitters

-67° to 374° ± 3°F

Direct engine mounted transmitters

b. Non-operating:

-85° to 293° ± 3°F

Remote mounted transmitters

-85° to 450° ± 3°F

Direct engine mounted transmitters

3.9.3 Pressure altitude. Pressure altitude up to 0.64 ± 0.1 inch Hg (85,000 ± 3,000 feet).

3.9.4 Vibration. The transmitter shall withstand the vibration conditions specified in tables I and II.

Table I. Shock mounted transmitters

Frequency (Hz)	Displacement in double amplitude (inch) and acceleration (g), if applicable
5-14	0.1
14-23	0.1 to 0.036 at ±1g
23-74	0.036
74-2000	0.036 to 0.01 at ±10g

MIL-PRF-5350G

Table II. Engine mounted transmitters

Frequency (Hz)	Displacement in double amplitude (inch) and acceleration (g), if applicable
5-10	0.2
10-18	0.2 to 0.06 at $\pm 1g$
18-99	0.06
99-2000	0.06 to 0.00015 at $\pm 30g$

4. VERIFICATION

4.1 Classification of inspections. The inspection requirements specified herein shall be in accordance with the associated specification and this document and are classified as follows:

- a. First article or qualification inspection (see 4.2).
- b. Conformance inspection (see 4.3).

4.2 First article or qualification inspection. Transmitters shall be subjected to all tests in 4.6 and the tests specified in the associated specification.

4.3 Conformance inspection. Conformance inspection shall consist of the following:

- a. Individual tests (see 4.3.1)
- b. Sampling tests (see 4.3.2)

4.3.1 Individual tests. Each transmitter shall be subjected to the following tests.

- a. Examination (see 4.6.1)
- b. Scale error at room temperature (see 4.6.2)
- c. Friction error (see 4.6.3)
- d. Aircraft attitude (see 4.6.4)
- e. Dielectric strength (see 4.6.5)
- f. Sealing (see 4.6.6)
- g. Electrical zero (see 4.6.7)

4.3.2 Sampling tests. Transmitters shall be subjected to the following sampling tests According to ANSI/ASQ Z1.4, at the inspection level (normal, tightened, or reduced) specified in the acquisition document (see 6.2).

- a. Electrical characteristics (see 4.6.8)
- b. Seasoning (see 4.6.9)

MIL-PRF-5350G

- c. Endurance (see 4.6.10)
- d. Power supply variations (see 4.6.12)
- e. Damping (see 4.6.13)
- f. Overscale (see 4.6.14)
- g. Low temperature (see 4.6.15)
- h. High temperature (see 4.6.16)
- i. Vibration (see 4.6.17)
- j. Low temperature exposure (see 4.6.18)
- k. Low pressure (see 4.6.19)
- l. Extreme high temperature (see 4.6.20)
- m. Acceleration (see 4.6.25)
- n. Torque (see 4.6.28)

4.4 Test conditions. Unless otherwise specified in the acquisition document, all inspections shall be performed in accordance with the test conditions described below, or as specified in the acquisition document.

4.4.1 Standard atmospheric condition. Unless otherwise specified in the individual test description, all tests shall be performed at ambient pressure and temperature.

4.4.2 Tapping. Unless otherwise specified in the individual test description, the transmitter shall be tapped before testing to overcome friction.

4.4.3 Test voltage. Unless otherwise specified in the individual test description, the transmitter shall be tested with the voltage and frequency specified in 3.5.5. The voltage and frequency shall be maintained within 1% of the nominal value.

4.4.4 Standard production indicating unit. The transmitters shall be tested with a standard production indicating unit with a maximum error of 0.5 degree.

4.5 Requirements cross-reference matrix. Table III provides a cross reference matrix of the section 3 requirements tested or verified in the paragraphs below.

Table III. Requirements cross-reference matrix

Requirement	Verification	Requirement	Verification
3.2	4.2	3.6.11	4.6.20.2
3.4	4.6.1, 4.6.22, 4.6.23	3.6.12	4.6.28
3.5.1	4.6.26	3.6.13	4.6.6
3.5.2	4.6.1	3.6.14	4.6.2
3.5.3	4.6.1	3.6.15	4.6.3
3.5.4	4.6.1	3.6.16	4.6.7
3.5.5	4.6.12	3.6.17	4.6.13
3.5.6	4.6.11	3.6.18.1	4.6.8

MIL-PRF-5350G

3.6.1	4.6.1, 4.6.26	3.6.18.2	4.6.8
3.6.2	4.6.27	3.6.18.3	4.6.8
3.6.3	4.6.26	3.6.18.4	4.6.26
3.6.4	4.6.5	3.7	4.6.1
3.6.5	4.6.9	3.8	4.6.1
3.6.6	4.6.10	3.9.1	4.6.4
3.6.7	4.6.24	3.9.2	4.6.15, 4.6.16, 4.6.18, 4.6.20
3.6.8	4.6.25	3.9.3	4.6.19
3.6.9	4.6.21	3.9.4	4.6.17
3.6.10	4.6.14		

4.6 Tests.

4.6.1 Examination. The transmitter shall be examined to determine compliance with materials, identification, weight, and those interface and performance requirements indicated in table III.

4.6.2 Scale error. The transmitter shall be tested for scale error at the test points specified in the acquisition document for both upscale and downscale readings. The test points on the upscale reading shall be measured by bringing the input reading up to, but not exceeding, the specified test point. The transmitter shall then be vibrated at a frequency of 3,600Hz with an amplitude of 0.002 inch. The difference in the scale error after vibration from the true input value shall not exceed the scale error tolerance specified in the acquisition document. The downscale error shall be measured in the same manner, except that the input reading value shall be brought down to, but not below, the specified test point.

4.6.3 Friction error. The difference in readings prior to application of the vibration specified in 4.6.2 and after application of vibration is friction error. The friction error shall not exceed the friction error tolerance specified in the acquisition document.

4.6.4 Aircraft attitude. The transmitter shall be energized to obtain a reading of one half scale on the indicating standard. The change in indication produced by rotating the transmitter from the normal operating position to a position 90° clockwise and counterclockwise (longitudinal axis vertical) shall not exceed the tolerance specified for position error in the acquisition document. The position error test may be conducted in conjunction with the scale error test.

4.6.5 Dielectric strength. An electric potential shall be applied between each pin of the electrical connector and the case for 5 seconds. There shall be no breakdown of the insulation. The potential shall be 500Vac if the case is not hermetically sealed, and 250Vac if the case is hermetically sealed.

4.6.6 Sealing (applicable to hermetically sealed transmitters only). The case shall be tested for leaks with a mass spectrometer helium detector. Where a nitrogen-helium mixture is

MIL-PRF-5350G

used as the fill medium, the detected leak rate shall not exceed 0.10 micron cubic foot per hour. Where 100% helium is used as the filling medium, the leak rate shall not exceed 1.0 micron cubic foot per hour.

4.6.7 Electrical zero. The (synchro) transmitter shall have R2 connected to S2, and 26Vac, 400Hz shall be applied to R1 and R2 for the following tests.

- a. Rotate the rotor until the voltage between R1 and S3 is minimum.
- b. Rotate the rotor counterclockwise approximately 30° until the voltage between S3 and S1 is minimum (null). This rotor position is electrical zero.
- c. Rotate the rotor clockwise 30° from electrical zero. The voltage between S3 and S2 shall increase and the voltage between S2 and S1 shall decrease during the rotation.

4.6.8 Electrical characteristics. The transmitter shall be tested for compliance with the requirements for open secondary, power input, and secondary voltage.

4.6.9 Seasoning. The transmitter shall be subjected 10,000 deflection cycles (see 6.3.4). One hour after the completion of this test, the transmitter shall be subjected to the scale error test and shall be within the tolerances in the acquisition document.

4.6.10 Endurance. The transmitter shall be subjected 60,000 deflection cycles (see 6.3.4). One hour after the completion of this test, the transmitter shall be subjected to the scale error test at ambient temperature, and shall be within the tolerances in the acquisition document.

4.6.11 Electromagnetic interference and compatibility. The transmitter shall be subjected to electromagnetic interference and compatibility tests as specified in MIL-STD-461 and MIL-STD-462. No "S" entries are defined for the transmitters covered by this specification for use in MIL-STD-461.

4.6.11.1 RS103 (Army only). The RS103 test limit shall average 200 volts/meter for 10kHz through 40GHz.

4.6.12 Power supply. The transmitter shall be subjected to the scale error and friction error tests at all combinations of 22, 24, 26, 28, and 30Vac and 320, 340, 360, 380, and 400Hz.

4.6.13 Damping. The transmitter shall drive the indicating standard from full scale deflection to the level, and in the time limit specified in the acquisition document.

4.6.14 Overscale. The transmitter shall be operated at 150% of full scale for a period of 10 minutes. The transmitter shall then be subjected to the scale error test. The three secondary leads of the synchro transmitter shall be connected to the corresponding leads of a synchro indicator conforming to MIL-I-7057 (see figures 2 and 3).

MIL-PRF-5350G

4.6.15 Low temperature. The transmitter shall be subjected to a temperature of $-67^{\circ} \pm 3^{\circ}\text{F}$ for 4 hours. At the end of this period and while still at this temperature, the transmitter shall be subjected to the friction and scale error tests.

4.6.16 High temperature. The transmitter shall be subjected to $250^{\circ} \pm 3^{\circ}\text{F}$ for remotely mounted transmitters or $374^{\circ} \pm 3^{\circ}\text{F}$ for direct engine mounted engine transmitters for a period of 6 hours. The transmitter shall be electrically connected to the standard production indicating unit with power applied during this test. At the end of this period, with the transmitter still at the test temperature, the transmitter shall be subjected to the scale error and friction error tests.

4.6.17 Vibration.

4.6.17.1 Shock mounted transmitter. Shock mounted transmitters shall be subjected to the vibration test in RTCA/DO-160, using the test levels specified in table I. Throughout the vibration test, an input shall be applied to the sensing element sufficient to produce approximately a half-scale indication on the indicating standard. The amplitude of pointer oscillation of the standard production indicating unit shall not exceed the tolerance specified in the acquisition document. Following the vibration period the transmitter shall be subjected to the scale error test on upscale readings only.

4.6.17.2 Direct engine mounted transmitters. Direct engine mounted transmitters shall be subjected to the vibration test in RTCA/DO-160, using the test levels specified in table II. Following the vibration period, the transmitter shall be subjected to the scale error test for upscale readings only.

4.6.18 Low temperature (non-operational). The transmitter shall be subjected to $-85^{\circ} \pm 3^{\circ}\text{F}$ for 50 hours. The temperature shall then be raised to $-65^{\circ} \pm 3^{\circ}\text{F}$ for 24 hours. The transmitter shall then be subjected to the low temperature test. The transmitter shall then be returned to room temperature for 4 hours and then subjected to the scale error test.

4.6.19 Pressure altitude. The transmitter shall be subjected to a pressure altitude test with an absolute internal chamber pressure of 0.64 ± 0.1 inch Hg ($85,000 \pm 3,000$ feet). The transmitter vent shall be held at the prevailing atmospheric pressure. The transmitter shall then be subjected to the scale error test for upscale pressure only.

4.6.20 High temperature (non-operational).

4.6.20.1 Remotely mounted transmitters. The transmitter shall be exposed to $293^{\circ} \pm 3^{\circ}\text{F}$ for 50 hours. The transmitter shall be returned to room temperature for 4 hours. The transmitter shall then be subjected to the scale error and friction error tests.

4.6.20.2 Direct engine-mounted transmitters. The transmitter shall be exposed to $450^{\circ} \pm 18^{\circ}\text{F}$ for 80 hours and returned to room temperature for 4 hours. The transmitter shall then be subjected to the scale error and friction error tests.

MIL-PRF-5350G

4.6.21 Humidity. The transmitters shall be subjected to the humidity test in RTCA/DO-160, Category B. External connections shall be made to the transmitter to simulate installed conditions. Immediately upon completion of the test, the transmitter shall be externally dried and subjected to scale error, friction error, and dielectric strength tests.

4.6.22 Salt fog. The transmitter shall be subjected to the salt fog test in ASTM B117. The transmitter shall be examined, and there shall be no evidence of external corrosion or deterioration. The transmitter shall then be subjected to the dielectric strength test. The impedance between the case and each pin shall be measured and shall be a minimum of 20 megohms. The external surface of the transmitter may be washed with distilled water and air-dried prior to its subjection to the dielectric strength test.

4.6.23 Fungus. The transmitter shall be subjected to the fungus test in RTCA/DO-160.

4.6.24 Shock. The transmitter shall be subjected to 20g for 11 milliseconds. The transmitter shall then be subjected to the scale error and friction error tests. The three secondary leads of the synchro transmitter shall be connected to the corresponding leads of a synchro indicator conforming to MIL-I-7057 (see figures 2 and 3).

4.6.25 Acceleration. The transmitter shall be subjected to the acceleration specified in the acquisition document. The acceleration shall be applied in each of the six cardinal directions. The transmitter shall then be subjected to the scale error and friction error tests. The three secondary leads of the synchro transmitter shall be connected to the corresponding leads of a synchro indicator conforming to MIL-I-7057 (see figures 2 and 3).

4.6.26 Compatibility. The manufacturer shall demonstrate compatibility with end item systems using the following tests. The three secondary leads of the synchro transmitter shall be connected to the corresponding leads of a synchro indicator conforming to MIL-I-7057 (see figures 2 and 3).

4.6.26.1 Bench test. The bench test shall be performed using an indicator of the type used on the end item or as specified in the acquisition document. The indicator shall conform to MIL-I-7057. The combination of the transmitter and indicator shall be subjected to the scale error test. The tolerance at each test point shall be the sum of the tolerances in the transmitter and indicator specified in the applicable specification sheet cited in the acquisition document.

4.6.26.2 Field test. The field test shall be performed with the transmitter installed in the end item. The transmitter shall be subjected to the scale error test.

4.6.26.3 Indicators. The transmitter shall be subjected to the scale error and function error tests while connected to one indicator. The transmitter shall then be subjected to the scale error and friction error tests while connected to 2 indicators. There shall be no more than 1 } change of indication.

MIL-PRF-5350G

4.6.27 Reliability. The manufacturer shall demonstrate that the transmitter has been subjected to a reliability test and has met the reliability required in the in the acquisition document.

4.6.28 Torque. The torque requirement shall be verified by a test designed by the manufacturer.

5. PACKAGING

5.1 Packaging. For acquisition purposes, the packaging requirements shall be as specified in the contract or order (see 6.2). When packaging of materiel is to be performed by DoD or in-house contractor personnel, these personnel need to contact the responsible packaging activity to ascertain packaging requirements. Packaging requirements are maintained by the Inventory Control Point's packaging activities within the Military Service or Defense Agency, or within the Military service's system commands. Packaging data retrieval is available from the managing Military Department's or Defense Agency's automated packaging files, CD-ROM products, or by contacting the responsible packaging activity.

6. NOTES

(This section contains information of a general or explanatory nature that may be helpful, but is not mandatory.)

6.1 Intended use. The synchro transmitters are intended to sense variable data and transmit signals dependent on their magnitudes to remote indicators.

6.2 Acquisition requirements. Acquisition document must specify the following:

- a. Title, number, and dates of this specification and the associated specification (see 3.1).
- b. Specification applicable to the procurement (see 3.1).
- c. Item identification requirements (see 3.7).
- d. Inspection level (normal, tightened, or reduced) for sampling tests (see 4.3.2).
- e. Data required.

6.3 Definitions.

6.3.1 Hermetic seal. A hermetic seal is defined as a perfectly closed and airtight seal made between vitric or metallic materials, or both. A hermetic seal is not intended to include seals accomplished by gaskets.

6.3.2 Synchro transmitter. The integral assembly of a transmitter and a data sensor.

6.3.3 Case distortion. Case distortion is defined as a minor malformation of the case caused by adjustment and installation that does not preclude proper operation.

MIL-PRF-5350G

6.3.4 Deflection cycle. Deflection cycles are the movement of the indicator from 0 to $85 \pm 5\%$ of full scale to 0 by the transmitter at a rate of $30 \pm 10\text{Hz}$.

6.4 Qualification. If the associated specification requires qualification, the attention of the contractors is called to the requirements with respect to products requiring qualification. Awards will be made only for products which are, at the time of award of contract, qualified for inclusion in Qualified Products List of the associated specification whether or not such products have actually been listed by that date. The attention of the manufacturers is called to these requirements and they are urged to arrange to have the products that they propose to offer to the Federal Government tested for qualification. Information pertaining to qualification of products may be obtained from af71@tinker.af.mil or mail to: Oklahoma City Air Logistics Center/ENSDDA, 3001 Staff Drive, Tinker AFB, OK 73145-3036. An online listing of products qualified to this specification may be found in the Qualified Products Database (QPD) at <http://assist.dap.mil> .

6.5 Subject term (key word) listing.

Electrical Zero
Friction Error
Scale Error
26Vac

6.6 Changes from previous issue. Marginal notations are not used in this revision to identify changes with respect to the previous issue due to the extent of the changes.

MIL-PRF-5350G

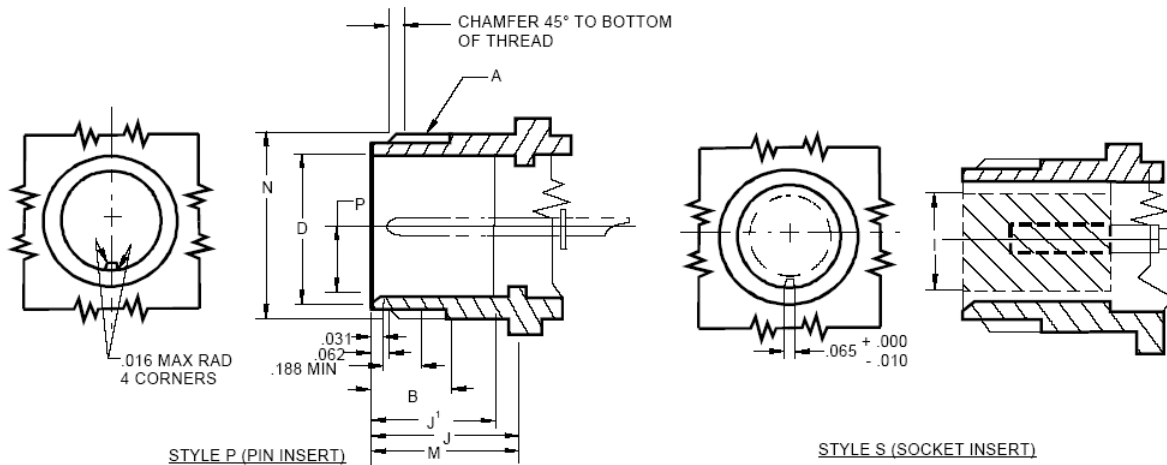

SIZE	A COUPLING THREAD	B MIN USABLE THREAD	D + .015 - .000 ID	I MAX INSERT DIA	J + .031 - .000	J' + .031 - .000 INSERT LOCATION	M + .031 - .000 MOUNTING FLANGE LOCATION	N MAX OD	P + .015 - .000 KEY HEIGHT
8S	1/2-28	.375	.370	.250	.562	.562	.562	.532	.130
10S	5/8-24		.448	.320				.656	.165
10SL			.557	.448				.782	.224
12S	3/4-20		.682	.525				.906	.263
14S	7/8-20		.807	.650				1.032	.325
16S	1-20	.625	.557	.448	.750	.750	.782	.224	
12	3/4-20		.682	.525			.906	.263	
14	7/8-20		.807	.650			1.032	.325	
16	1-20		.932	.770			1.156	.385	
18	1-1/8-18		1.058	.925			1.282	.463	
20	1-1/4-18		1.182	1.020			1.406	.510	
22	1-3/8-18		1.307	1.145			1.532	.573	
24	1-1/2-18		1.526	1.365			1.782	.683	
28	1-3/4-18		1.776	1.615			2.032	.808	
32	2-18		.875	1.995			1.830	2.282	.915
36	2-1/4-16								

- NOTES:
- WHERE RESILIENT INSERTS ARE USED, J' MAY BE .109 LESS THAN INDICATED.
 - MS3102R OR MODIFICATION THEREOF, MAY BE USED IN LIEU OF THIS DESIGN.
 - DIMENSIONS IN INCHES. UNLESS OTHERWISE SPECIFIED, TOLERANCES: DECIMALS ± .016.
 - THE PART NUMBER OF THE ELECTRICAL CONNECTOR IS BROKEN DOWN IN THE FOLLOWING MANNER. 14S REFERS TO THE SIZE IN THE TABLE ABOVE. -2 REFERS TO THE INSERT ARRANGEMENT DESCRIBED IN MIL-STD-1651. P IS A PIN INSERT IN THE ABOVE FIGURE.

FIGURE 1. Electrical connectors

MIL-PRF-5350G

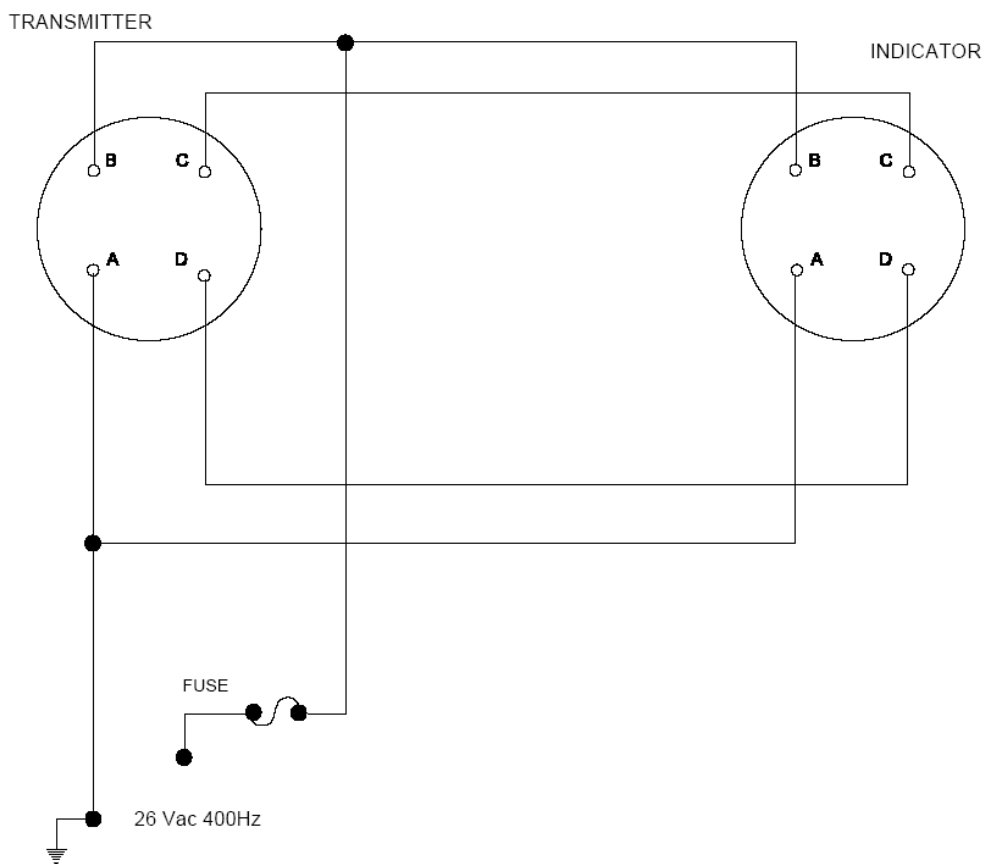

FIGURE 2. Single indicator configuration

MIL-PRF-5350G

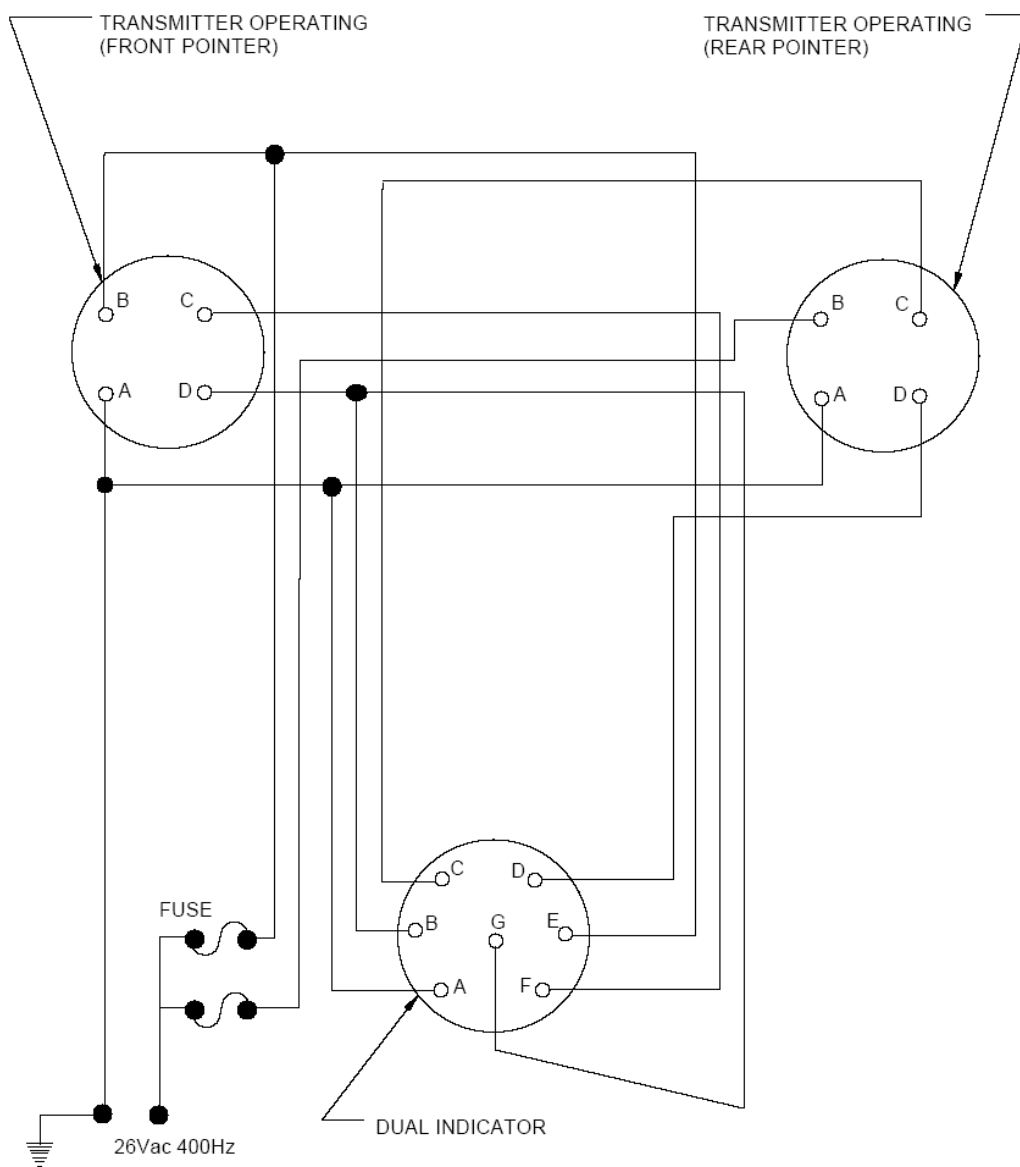

FIGURE 3. Dual indicator configuration

MIL-PRF-5350G

Custodians:

Air Force - 71

Navy - AS

Army - AV

Preparing activity:

Air Force - 71

(Project 6620-2009-002)

Reviewer activities:

DLA - GS

“NOTE: The activities listed above were interested in this document as of date of this document. Since organizations and responsibilities can change, you should verify the currency of the information above using the ASSIST Online database at <http://assist.daps.dla.mil>.