

✓

MIL-HDBK-1032/2  
30 SEPTEMBER 1987  
SUPERSEDING  
NAVFAC DM-32  
1 June 1982

MILITARY HANDBOOK

COVERED STORAGE



NO DELIVERABLE DATA REQUIRED BY THIS DOCUMENT

DISTRIBUTION STATEMENT A. APPROVED FOR PUBLIC RELEASE: DISTRIBUTION IS  
UNLIMITED

AREA FACR

MIL-HDBK-1032/2

ABSTRACT

Design criteria are presented as guidance for use by experienced architects and engineers to assure that appropriate layout and design considerations are included in the design of facilities in Category Code 400. The contents include general facility planning and layout guidance, as well as specific facility requirements for flammable/hazardous storage, heavy materials storage, cold storage, shed storage, and controlled humidity storage. General guidance is also included for modernization of existing warehouse buildings.

MIL-HDBK-1032/2

FOREWORD

This military handbook has been developed from an evaluation of facilities in the shore establishment, surveys of the availability of new materials and construction methods, and selection of the best design practices of the Naval Facilities Engineering Command (NAVFACENGCOM), other Government agencies, and the private sector. This manual uses, to the maximum extent feasible, national professional society, association, and institute standards in accordance with NAVFACENGCOM policy. Deviations from these criteria in the planning, engineering, design, and construction of Naval shore facilities cannot be made without prior approval of NAVFACENGCOM Headquarters (Code 04).

Design cannot remain static any more than can the naval functions it serves or the technologies it uses. Accordingly, recommendations for improvement are encouraged and should be furnished on the DOD Form 1426 provided inside the back cover, to Chesapeake Division, Naval Facilities Engineering Command, Building 212, Washington Navy Yard, Washington, DC 20374-2121, telephone 202-433-3314.

THIS HANDBOOK SHALL NOT BE USED AS A REFERENCE DOCUMENT FOR PROCUREMENT OF FACILITIES CONSTRUCTION. IT IS TO BE USED IN THE PURCHASE OF FACILITIES ENGINEERING STUDIES AND DESIGN (FINAL PLANS, SPECIFICATIONS, AND COST ESTIMATES). DO NOT REFERENCE IT IN MILITARY OR FEDERAL SPECIFICATIONS OR OTHER PROCUREMENT DOCUMENTS.

## MIL-HDBK-1032/2

STORAGE CRITERIA MANUALS

| <u>Criteria Manual</u> | <u>Title</u>    | <u>PA</u> |
|------------------------|-----------------|-----------|
| DM-32.01               | Open Storage    | CHESDIV   |
| MIL-HDBK-1032/2        | Covered Storage | CHESDIV   |

Note: Design manuals, when revised, will be converted to military handbooks and listed in the military handbook section of NAVFAC P-34.

## MIL-HDBK-1032/2

## COVERED STORAGE

## CONTENTS

|           |  | <u>Page</u> |
|-----------|--|-------------|
| Section 1 | CRITERIA FOR COVERED STORAGE BUILDINGS .....             | 1           |
| 1.1       | Scope.....   | 1           |
| 1.2       | Cancellation.....  | 1           |
| 1.3       | Related Criteria.....                                    | 1           |
| 1.3.1     | DOD Construction Criteria.....                           | 1           |
| 1.3.2     | Requirements of Other Commands or Bureaus.....           | 1           |
| 1.3.3     | Facility Plates.....                                     | 1           |
| 1.3.4     | Definitive Drawings.....                                 | 2           |
| 1.3.5     | Other Sources.....                                       | 2           |
| 1.4       | Classification of Facility Groups.....                   | 2           |
| 1.4.1     | Cold Storage (Code 431-10).....                          | 2           |
| 1.4.1.1   | Material Categories.....                                 | 2           |
| 1.4.1.2   | Exclusions.....  | 2           |
| 1.4.2     | General Warehouse Navy (Code 441-10).....                | 2           |
| 1.4.3     | Controlled Humidity Warehouse (Code 441-20).....         | 2           |
| 1.4.4     | Flammable/Hazardous Storehouse (Code 441-30).....        | 3           |
| 1.4.5     | Shed Storage (Code 441-35).....                          | 3           |
| 1.5       | Storage Categories Not Addressed                         |             |
|           | In This Handbook.....                                    | 3           |
| 1.5.1     | Liquid Storage - Fuel and NonPropellants (Code 410)..... | 3           |
| 1.5.2     | Ammunition Storage (Code 420).....                       | 4           |
| 1.5.3     | Open Storage (Code 450).....                             | 4           |
| Section 2 | PLANNING FACTORS.....                                    | 5           |
| 2.1       | Geographic Location.....                                 | 5           |
| 2.1.1     | Tropical Regions.....                                    | 5           |
| 2.1.2     | Cold Regions.....  | 5           |
| 2.1.3     | Mountainous Areas.....                                   | 5           |
| 2.1.4     | Desert Areas.....  | 5           |
| 2.1.5     | Waterfront Areas.....                                    | 5           |
| 2.2       | Site Planning.....                                       | 5           |
| 2.2.1     | Vehicle Access.....                                      | 5           |
| 2.2.2     | Rail Access.....   | 5           |
| 2.2.3     | Grading and Drainage.....                                | 6           |
| 2.2.3.1   | Groundwater.....   | 6           |
| 2.2.3.2   | Roof Drainage.....                                       | 6           |
| 2.2.3.3   | Site Grading.....  | 6           |
| 2.2.3.4   | Cut and Fill.....  | 6           |
| 2.2.4     | Utilities.....   | 6           |
| 2.2.5     | Security.....  | 6           |
| 2.3       | Storage/Handling System Selection.....                   | 6           |
| 2.3.1     | Design Parameters.....                                   | 6           |
| 2.3.1.1   | Load Size.....   | 6           |
| 2.3.1.2   | Transaction Activity.....                                | 7           |
| 2.3.1.3   | Standards.....   | 7           |

## MIL-HDBK-1032/2

|         | <u>Page</u>                                    |    |
|---------|--|----|
| 2.3.1.4 | Storage Height.....                            | 7  |
| 2.3.2   | Procedures.....                                | 7  |
| 2.3.2.1 | Define Inventory.....                          | 7  |
| 2.3.2.2 | Define Daily Transactions.....                 | 7  |
| 2.3.2.3 | Define Available Area.....                     | 7  |
| 2.3.2.4 | Compute Transaction/Inventory (T/I) Ratio..... | 7  |
| 2.3.2.5 | Select System.....                             | 7  |
| 2.3.2.6 | Determine Cost.....                            | 7  |
| 2.3.2.7 | Determine Area.....                            | 9  |
| 2.3.2.8 | Determine Support Requirements.....            | 9  |
| 2.3.2.9 | Integrate Layout.....                          | 9  |
| 2.3.3   | Materials Handling Equipment.....              | 9  |
| 2.3.3.1 | Pallet Handling Equipment.....                 | 9  |
| 2.3.3.2 | Order Picking Equipment.....                   | 9  |
| 2.3.3.3 | Transport Systems.....                         | 9  |
| 2.3.4   | Storage Equipment.....                         | 9  |
| 2.3.4.1 | Pallet Rack.....                               | 9  |
| 2.3.4.2 | Shelving/Bins.....                             | 9  |
| 2.3.4.3 | Special.....                                   | 9  |
| 2.3.4.4 | Installation and Operation Tolerances.....     | 9  |
| 2.4     | System Considerations.....                     | 10 |
| 2.4.1   | Receiving/Shipping Operations.....             | 10 |
| 2.4.2   | Order Picking Operations.....                  | 10 |
| 2.4.3   | Support Areas.....                             | 10 |
| 2.4.3.1 | Supervisory Offices.....                       | 10 |
| 2.4.3.2 | Receiving Office.....                          | 12 |
| 2.4.3.3 | Shipping Office.....                           | 12 |
| 2.4.3.4 | Rest Rooms.....                                | 12 |
| 2.4.3.5 | Employee Services.....                         | 12 |
| 2.4.3.6 | Crating Operations.....                        | 12 |
| 2.4.3.7 | Packing/Packaging Operations.....              | 12 |
| 2.4.4   | Parking.....                                   | 12 |
| 2.4.5   | Traffic Flow.....                              | 15 |
| 2.4.6   | Safety.....                                    | 15 |
| 2.5     | System Costs.....                              | 15 |
| 2.5.1   | Investment Cost.....                           | 15 |
| 2.5.1.1 | Research and Development.....                  | 15 |
| 2.5.1.2 | Facility Investment.....                       | 15 |
| 2.5.1.3 | Working Capital Changes.....                   | 15 |
| 2.5.1.4 | Value of Existing Assets Employed.....         | 15 |
| 2.5.1.5 | Value of Existing Assets Replaced.....         | 16 |
| 2.5.1.6 | Terminal Value.....                            | 16 |
| 2.5.2   | Recurring Cost.....                            | 16 |
| 2.5.2.1 | Personnel Cost.....                            | 16 |
| 2.5.2.3 | Other.....                                     | 16 |
| 2.5.3   | Life-Cycle Cost.....                           | 16 |
| 2.6     | Technical Approval.....                        | 16 |
| 2.6.1   | Layout and Flow Concept.....                   | 16 |
| 2.6.2   | Architectural Design.....                      | 18 |
| 2.7     | Computer Design Aids.....                      | 18 |

## MIL-HDBK-1032/2

|           | <u>Page</u>                                     |
|-----------|---|
| Section 3 | BUILDING REQUIREMENTS..... 19                   |
| 3.1       | General Design Factors..... 19                  |
| 3.1.1     | Materials Movement..... 19                      |
| 3.1.2     | Expansion Capability..... 19                    |
| 3.1.3     | Flexibility of Design..... 19                   |
| 3.1.4     | Requirements of Specific Buildings..... 19      |
| 3.2       | Building Shape and Proportions..... 19          |
| 3.2.1     | Travel Distance..... 19                         |
| 3.2.2     | Irregular Shapes..... 19                        |
| 3.2.3     | Height..... 19                                  |
| 3.2.4     | Area..... 19                                    |
| 3.3       | Building Spacing..... 23                        |
| 3.3.1     | Rail Side..... 23                               |
| 3.3.2     | Truck Side..... 23                              |
| 3.3.3     | Warehouses In-line..... 23                      |
| 3.3.4     | Flammable/Hazardous Material Facilities..... 23 |
| 3.4       | Docking Facilities..... 23                      |
| 3.4.1     | Truck Docks..... 23                             |
| 3.4.2     | Rail Docks..... 32                              |
| 3.4.2.1   | Outside Docks..... 32                           |
| 3.4.2.2   | Inside Docks..... 32                            |
| 3.4.2.3   | Platforms..... 32                               |
| 3.4.3     | Ramp Access..... 32                             |
| 3.4.4     | Dock Levelers..... 32                           |
| 3.4.5     | Dock Weather Protection..... 32                 |
| 3.4.5.1   | Dock Shelters..... 32                           |
| 3.4.5.2   | Door Seals..... 32                              |
| 3.4.5.3   | Canopy..... 36                                  |
| 3.4.6     | Safety Equipment..... 36                        |
| 3.5       | Construction..... 36                            |
| 3.5.1     | Construction Materials..... 36                  |
| 3.5.2     | Foundation..... 36                              |
| 3.5.3     | Structural Frame..... 36                        |
| 3.5.3.1   | Selection Factors..... 36                       |
| 3.5.3.2   | Conventional Construction..... 39               |
| 3.5.3.3   | Rack Supported Construction..... 39             |
| 3.5.4     | Roof..... 39                                    |
| 3.5.4.1   | Flat Roofs..... 39                              |
| 3.5.4.2   | Sloped Roofs..... 39                            |
| 3.5.5     | Exterior Walls..... 39                          |
| 3.5.6     | Interior Walls..... 39                          |
| 3.5.6.1   | Fixed Partitions..... 41                        |
| 3.5.6.2   | Movable Partitions..... 41                      |
| 3.5.6.3   | Wire Mesh Partitions..... 41                    |
| 3.5.7     | Doors and Windows..... 41                       |
| 3.5.8     | Interior Finishes..... 41                       |
| 3.5.9     | Plumbing..... 41                                |
| 3.5.10    | Mechanical..... 41                              |
| 3.5.11    | Electrical..... 42                              |
| 3.6       | Floors..... 42                                  |

## MIL-HDBK-1032/2

|         | <u>Page</u>                                      |
|---------|--|
| 3.6.1   | Floor Construction..... 42                       |
| 3.6.1.1 | Concrete Strength..... 42                        |
| 3.6.1.2 | Reinforcement..... 42                            |
| 3.6.1.3 | Flatness..... 42                                 |
| 3.6.1.4 | Thickness..... 42                                |
| 3.6.1.5 | Finishes..... 42                                 |
| 3.6.1.6 | Static Load..... 44                              |
| 3.6.1.7 | Impact Load..... 44                              |
| 3.6.2   | Superflat Floors..... 44                         |
| 3.6.2.1 | Construction Guidelines..... 44                  |
| 3.6.2.2 | Measurement..... 44                              |
| 3.6.3   | Wire Guide Requirements..... 45                  |
| 3.6.3.1 | Conduits..... 45                                 |
| 3.6.3.2 | Reinforcing..... 45                              |
| 3.6.3.3 | Expansion Joints..... 45                         |
| 3.6.3.4 | Hardening Agents..... 45                         |
| 3.7     | Fire Protection..... 45                          |
| 3.7.1   | Location of Buildings..... 45                    |
| 3.7.2   | Fire Apparatus Access..... 45                    |
| 3.7.3   | Separation Distance..... 46                      |
| 3.7.4   | Protected Area..... 46                           |
| 3.7.4.1 | General Storage..... 46                          |
| 3.7.4.2 | Flammable/Hazardous Storage..... 46              |
| 3.7.5   | Sprinkler Systems..... 46                        |
| 3.7.5.1 | Storage System Sprinklers..... 46                |
| 3.7.5.2 | Water Supply..... 50                             |
| 3.7.6   | Hose Connections..... 50                         |
| 3.7.7   | Fire Walls..... 50                               |
| 3.7.8   | Fire Doors..... 50                               |
| 3.7.9   | Ventilation..... 50                              |
| 3.8     | Architectural Details..... 50                    |
| 3.8.1   | Battery Charging and Handling Operations..... 51 |
| 3.8.1.1 | Safety Showers/Spill Control..... 51             |
| 3.8.1.2 | Fire Extinguishing Equipment..... 51             |
| 3.8.1.3 | Battery Handling Equipment..... 51               |
| 3.8.1.4 | Ventilation..... 51                              |
| 3.8.2   | Pallet Racks..... 55                             |
| 3.8.2.1 | Dimensions..... 55                               |
| 3.8.2.2 | Stability..... 55                                |
| 3.8.2.3 | Flue Space..... 55                               |
| 3.8.2.4 | Attachment..... 55                               |
| 3.8.2.5 | System Interface..... 55                         |
| 3.8.3   | Aisle Dimensions..... 55                         |
| 3.8.3.1 | Rail Guidance..... 55                            |
| 3.8.3.2 | Wire Guidance..... 55                            |
| 3.8.3.3 | Transport Aisles..... 55                         |
| 3.8.4   | Building Bay Dimensions..... 55                  |
| 3.8.4.1 | Universal Bay Size..... 64                       |
| 3.8.4.2 | Optimum Bay Size..... 64                         |
| 3.8.4.3 | Comparison of Bay Sizes..... 64                  |



## MIL-HDBK-1032/2

|           |  | <u>Page</u> |
|-----------|--|-------------|
| 3.8.4.4   | Clear Storage Height.....                    | 64          |
| 3.8.5     | Communication Systems.....                   | 64          |
| 3.8.6     | Alarm Systems.....                           | 66          |
| 3.8.6.1   | Fire Alarms.....                             | 67          |
| 3.8.6.2   | Hazardous Chemical Spill Alarms.....         | 67          |
| 3.8.6.3   | Security Alarms.....                         | 67          |
| 3.8.7     | Door Clearances.....                         | 67          |
| 3.8.7.1   | Door Height.....                             | 67          |
| 3.8.7.2   | Door Width.....                              | 67          |
| 3.8.8     | Signage.....                                 | 67          |
| 3.8.8.1   | Identification.....                          | 67          |
| 3.8.8.2   | Warning.....                                 | 67          |
| 3.8.9     | Pest Control.....                            | 67          |
| 3.8.10    | Design for Handicapped.....                  | 69          |
| 3.9       | Seismic Design.....                          | 69          |
| 3.9.1     | Facility Loss Potential.....                 | 69          |
| 3.9.1.1   | Essential Facilities.....                    | 69          |
| 3.9.1.2   | High Risk Facilities.....                    | 69          |
| 3.9.1.3   | Other Facilities.....                        | 69          |
| 3.9.2     | Effects on Storage System Design.....        | 69          |
| 3.10      | Environmental Control.....                   | 69          |
| 3.10.1    | Heating System.....                          | 69          |
| 3.10.2    | Heating Plant.....                           | 70          |
| 3.10.3    | Air Conditioning.....                        | 70          |
| 3.10.4    | Humidity Control.....                        | 70          |
| 3.10.5    | Energy Conservation.....                     | 70          |
| 3.10.6    | Insulation.....                              | 70          |
| 3.11      | Electrical Requirements.....                 | 70          |
| 3.11.1    | Illumination.....                            | 70          |
| 3.11.2    | Lighting Fixtures.....                       | 72          |
| 3.11.3    | Receptacles.....                             | 72          |
| 3.11.4    | Battery Chargers.....                        | 72          |
| 3.11.5    | Emergency Lighting.....                      | 72          |
| 3.12      | Plumbing Requirements.....                   | 72          |
| 3.12.1    | Cold Water.....                              | 72          |
| 3.12.2    | Hot Water.....                               | 72          |
| 3.12.3    | Floor Drains.....                            | 72          |
| Section 4 | FLAMMABLE/HAZARDOUS MATERIALS WAREHOUSE..... | 73          |
| 4.1       | Definition.....                              | 73          |
| 4.1.1     | Compliance Standards.....                    | 73          |
| 4.1.1.1   | Federal Regulations.....                     | 73          |
| 4.1.1.2   | National Fire Protection Association.....    | 73          |
| 4.1.1.3   | Other Criteria.....                          | 74          |
| 4.1.2     | Hazardous Materials Storage Facilities.....  | 74          |
| 4.1.3     | Design Criteria.....                         | 74          |
| 4.1.4     | Storage Requirements.....                    | 74          |
| 4.1.5     | Materials Handling Equipment.....            | 74          |
| 4.2       | Segregation of Materials.....                | 75          |
| 4.2.1     | Categories of Materials.....                 | 75          |

## MIL-HDBK-1032/2

|           |   | <u>Page</u> |
|-----------|---|-------------|
| 4.2.1.1   | Flammable and Combustible Liquids.....  | 75          |
| 4.2.1.2   | Acids.....                              | 75          |
| 4.2.1.3   | Oxidizers.....                          | 75          |
| 4.2.1.4   | Poisons.....                            | 75          |
| 4.2.1.5   | Water Reactive Materials.....           | 75          |
| 4.2.1.6   | Caustics.....                           | 76          |
| 4.2.1.7   | Organic Peroxides.....                  | 76          |
| 4.2.2     | Segregation Requirements.....           | 76          |
| 4.2.2.1   | Compressed Gas Cylinders.....           | 76          |
| 4.2.2.2   | Drummed POL.....                        | 76          |
| 4.2.2.3   | Other Materials.....                    | 76          |
| 4.3       | Building Layout.....                    | 76          |
| 4.3.1     | Relationship to Other Buildings.....    | 76          |
| 4.3.2     | Area and Height Restrictions.....       | 76          |
| 4.3.3     | Combined Shed Storage.....              | 78          |
| 4.4       | Construction.....                       | 78          |
| 4.4.1     | Structural Elements.....                | 78          |
| 4.4.2     | Fire Walls.....                         | 78          |
| 4.4.3     | Doors.....                              | 78          |
| 4.4.4     | Explosion Relief.....                   | 78          |
| 4.4.5     | Floor Coatings.....                     | 78          |
| 4.4.6     | Showers and Eye Wash Stations.....      | 78          |
| 4.4.7     | Ventilation.....                        | 78          |
| 4.4.8     | Lightning Protection.....               | 80          |
| 4.4.9     | Alarms.....                             | 80          |
| 4.5       | Spill Containment and Control.....      | 80          |
| 4.5.1     | Dikes.....                              | 80          |
| 4.5.2     | Floor Trenches and Capture Systems..... | 80          |
| 4.5.2.1   | Electronic Guide Wire Crossing.....     | 80          |
| 4.5.2.2   | Personnel Exits.....                    | 80          |
| 4.5.3     | Recessed Floors.....                    | 80          |
| 4.5.4     | Containment.....                        | 83          |
| 4.5.5     | Drainage.....                           | 83          |
| 4.6       | Automatic Fire Suppression Systems..... | 83          |
| 4.6.1     | Design Requirements.....                | 83          |
| 4.6.2     | Sprinkler Adjustment.....               | 83          |
| Section 5 | HEAVY MATERIALS WAREHOUSE.....          | 84          |
| 5.1       | Definition.....                         | 84          |
| 5.2       | Construction.....                       | 84          |
| 5.2.1     | Doors/Windows.....                      | 84          |
| 5.2.2     | Floors.....                             | 84          |
| 5.2.3     | Craneways.....                          | 84          |
| 5.3       | Site Planning.....                      | 84          |
| 5.3.1     | Rail Access.....                        | 84          |
| 5.3.2     | Truck Access.....                       | 84          |
| 5.3.3     | Expansion.....                          | 84          |
| Section 6 | COLD STORAGE WAREHOUSE.....             | 85          |
| 6.1       | Definition.....                         | 85          |

## MIL-HDBK-1032/2

|           | <u>Page</u>                                   |
|-----------|---|
| 6.2       | Construction..... 85                          |
| 6.2.1     | DOD Requirements..... 85                      |
| 6.2.2     | Construction Details..... 85                  |
| 6.2.3     | Doors/Windows..... 85                         |
| 6.2.4     | Floors..... 85                                |
| 6.2.5     | Floor Drains..... 85                          |
| 6.2.6     | Insulation..... 85                            |
| 6.2.6.1   | Cost of Insulation..... 85                    |
| 6.2.6.2   | Selection..... 86                             |
| 6.2.6.3   | Mechanical Protection for Insulation..... 86  |
| 6.2.7     | Exterior Finishes..... 86                     |
| 6.2.8     | Interior Finishes..... 86                     |
| 6.2.9     | Vapor Barrier System..... 86                  |
| 6.2.10    | Sealants, Fasteners, and Adhesives..... 87    |
| 6.2.11    | Built-up Roofing Over Deck Insulation..... 87 |
| 6.2.12    | Doors..... 87                                 |
| 6.2.13    | Refrigeration Systems..... 87                 |
| 6.2.14    | Special Equipment Ratings..... 87             |
| 6.2.15    | Alarms..... 87                                |
| 6.2.15.1  | Safety Alarm..... 87                          |
| 6.2.15.2  | Security Alarm..... 87                        |
| 6.2.15.3  | High Temperature Alarm..... 87                |
| 6.3       | Sprinklers..... 88                            |
| 6.3.1     | Design Requirements..... 88                   |
| 6.3.2     | Drainage..... 88                              |
| 6.3.3     | Floor Flatness..... 88                        |
| 6.4       | Electrical Requirements..... 88               |
| 6.4.1     | Lighting Fixtures..... 88                     |
| 6.4.2     | Illumination Levels..... 88                   |
| 6.4.3     | Other Equipment..... 88                       |
| 6.5       | Inspection Area..... 88                       |
| 6.6       | Storage Requirements..... 88                  |
| 6.6.1     | Storage Height..... 90                        |
| 6.6.2     | Spacing of Pallets..... 90                    |
| 6.6.3     | Maximum Aisle Width..... 90                   |
| 6.6.4     | Pallet Rack Attachment..... 90                |
| 6.6.5     | Volume Efficiency..... 90                     |
| Section 7 | SHED STORAGE..... 91                          |
| 7.1       | Definition..... 91                            |
| 7.1.1     | General Purpose Shed..... 91                  |
| 7.1.2     | Transitory Shed..... 91                       |
| 7.1.3     | Flammable/Hazardous Materials Shed..... 91    |
| 7.2       | General Requirements..... 91                  |
| 7.2.1     | Layout..... 91                                |
| 7.2.1.1   | Shape and Proportion..... 91                  |
| 7.2.1.2   | Access..... 91                                |
| 7.2.2     | Support Areas..... 91                         |
| 7.2.2.1   | Supervisory Offices..... 91                   |
| 7.2.2.2   | Employee Service Areas..... 92                |

## MIL-HDBK-1032/2

|           |   | <u>Page</u> |
|-----------|---|-------------|
| 7.2.2.3   | Other Support Areas.....  | 92          |
| 7.2.3     | Storage Areas.....  | 92          |
| 7.2.4     | Storage Surface.....  | 92          |
| 7.2.4.1   | Improved.....   | 92          |
| 7.2.4.2   | Semi-Improved.....  | 92          |
| 7.2.5     | Drainage.....   | 92          |
| 7.2.6     | Utilities.....  | 92          |
| 7.2.6.1   | Water, Plumbing, and Sanitary Sewer.....                          | 93          |
| 7.2.6.2   | Electrical.....   | 93          |
| 7.2.6.3   | Communications.....   | 93          |
| 7.2.7     | Security.....   | 93          |
| 7.2.7.1   | Fencing.....  | 93          |
| 7.2.7.2   | Surveillance.....   | 93          |
| 7.2.7.3   | Lighting.....   | 93          |
| 7.2.8     | Preservation Measures.....  | 93          |
| 7.2.8.1   | Direct Exposure.....  | 93          |
| 7.2.8.2   | Corrosive Environment, Humidity, and<br>Temperature Extremes..... | 93          |
| 7.3       | Bottled Gas and Drummed POL Storage.....                          | 93          |
| 7.3.1     | Layout.....   | 93          |
| 7.3.2     | Drainage/Containment.....   | 94          |
| 7.3.3     | Sprinklers.....   | 94          |
| 7.3.4     | Fire Walls/Fire Doors.....  | 94          |
| 7.3.5     | Ventilation.....  | 94          |
| Section 8 | CONTROLLED HUMIDITY WAREHOUSING.....                              | 95          |
| 8.1       | Dehumidification.....   | 95          |
| 8.2       | Carbon Monoxide Control.....                                      | 95          |
| 8.3       | New Construction.....   | 95          |
| 8.3.1     | Floors.....   | 95          |
| 8.3.2     | Walls.....  | 95          |
| 8.3.2.1   | Joints.....   | 95          |
| 8.3.2.2   | Sides and End Laps.....   | 95          |
| 8.3.2.3   | Fire Walls.....   | 95          |
| 8.3.2.4   | Junctions.....  | 95          |
| 8.3.3     | Roof.....   | 95          |
| 8.3.4     | Doors.....  | 96          |
| 8.3.4.1   | Personnel Doors.....  | 96          |
| 8.3.4.2   | Fire Doors.....   | 96          |
| 8.4       | Conversion of Existing Structures to<br>Dehumidified Storage..... | 96          |
| 8.4.1     | Ventilators.....  | 96          |
| 8.4.2     | Openings.....   | 96          |
| 8.4.3     | New Doors.....  | 96          |
| 8.4.4     | Active Doors.....   | 96          |
| 8.4.5     | Excess Doors.....   | 96          |
| Section 9 | MODERNIZATION OF EXISTING GENERAL WAREHOUSE<br>BUILDINGS.....     | 97          |
| 9.1       | Purpose.....  | 97          |

## MIL-HDBK-1032/2

|         | <u>Page</u>                        |
|---------|------------------------------------|
| 9.2     | Architectural Requirements..... 97 |
| 9.2.1   | Floors..... 97                     |
| 9.2.2   | Interior Finishes..... 97          |
| 9.2.3   | Design for Handicapped..... 97     |
| 9.2.4   | Roof..... 97                       |
| 9.2.5   | Doors and Windows..... 97          |
| 9.3     | Structural Requirements..... 97    |
| 9.3.1   | Structural Systems..... 97         |
| 9.3.1.1 | Steel Members..... 97              |
| 9.3.1.2 | Concrete Members..... 97           |
| 9.3.1.3 | Wood Members..... 98               |
| 9.3.2   | Modifications..... 98              |
| 9.4     | Plumbing Requirements..... 98      |
| 9.5     | Electrical Requirements..... 98    |
| 9.6     | Mechanical Requirements..... 98    |
| 9.7     | Fire Protection..... 98            |
| 9.8     | Asbestos..... 98                   |

## APPENDICES

|            |  |
|------------|--|
| APPENDIX A | Illustrations of Typical Cold Storage Construction<br>and Insulation..... 99 |
|------------|--|

## MIL-HDBK-1032/2

Page

## FIGURES

|    |  |    |
|----|--|----|
| 1  | System Selection Flowchart.....  | 8  |
| 2  | Typical Receiving Office (Functional Dimensions).....  | 13 |
| 3  | Typical Shipping Office (Functional Dimensions).....   | 14 |
| 4  | Facility Design Process Flowchart.....   | 17 |
| 5  | Building Elevation Parameters.....   | 22 |
| 6  | Truck Apron Criteria (Functional Dimensions).....  | 24 |
| 7  | Building Protection Devices.....   | 25 |
| 8  | Truck Dock Configurations.....   | 27 |
| 9  | Typical Truck Dock (Section).....  | 28 |
| 10 | Typical Truck Dock (Plan).....   | 29 |
| 11 | Truck Apron Section.....   | 30 |
| 12 | Door Size Characteristics.....   | 31 |
| 13 | Rail Car Characteristics.....  | 33 |
| 14 | Truck Dock Weather Seals.....  | 35 |
| 15 | Truck Dock Canopy.....   | 37 |
| 16 | Trailer Restraint System.....  | 38 |
| 17 | Exterior Wall Detail.....  | 40 |
| 18 | Floor Loading Nomograph.....   | 43 |
| 19 | Standard Navy In-Rack Sprinkler Arrangement (Class I, II, III,<br>IV Commodity Storage Height Over 25 Feet - Excludes Flam/Haz<br>Storage Facilities)..... | 47 |
| 20 | Standard Navy Face and Longitudinal Flue Sprinkler Mounting<br>(To Prevent Pallet and Load Interference).....  | 48 |
| 21 | Standard Navy Flammable/Hazardous Flue Sprinkler System (To<br>Permit Adjustment of Flam/Haz Rack Shelves - Face Sprinklers<br>Not Required).....          | 49 |
| 22 | Battery Charging Area (Open Locations).....  | 52 |
| 23 | Battery Charging Area (One-Entrance Room).....   | 53 |
| 24 | Typical Battery Charger Installation (with Eye Wash/Shower).....   | 54 |
| 25 | Pallet Rack Terminology.....   | 56 |
| 26 | Navy/DOD Pallet Arrangement.....   | 57 |
| 27 | Standard Pallet Rack Elevation.....  | 58 |
| 28 | Pallet Rack Fire Protection Terminology.....   | 59 |
| 29 | Pickup and Delivery (P&D) Stations.....  | 60 |
| 30 | Typical Rail Guidance System.....  | 61 |
| 31 | Typical Wire Guidance System.....  | 62 |
| 32 | Building Column Spacing Parameters.....  | 65 |
| 33 | Typical Safety Markings.....   | 68 |
| 34 | Flammable/Hazardous Materials Storage Segregation Block Layouts.   | 77 |
| 35 | Spill Capture/Containment System.....  | 81 |
| 36 | Electronic Guide Wire Crossing.....  | 82 |

## MIL-HDBK-1032/2

|      | <u>Page</u>   |
|------|---|
| A-1  | Cold Room Insulation Detail 1..... 100  |
| A-2  | Cold Room Insulation Detail 2..... 101  |
| A-3  | Cold Room Insulation Detail 3..... 102  |
| A-4  | Cold Room Insulation Detail 4..... 103  |
| A-5  | Cold Room Insulation Detail 5..... 104  |
| A-6  | Cold Room Insulation Detail 6..... 105  |
| A-7  | Cold Room Insulation Detail 7..... 106  |
| A-8  | Enlarged Cold Room Insulation Detail..... 107   |
| A-9  | Cold Room Insulation Detail 8..... 108  |
| A-10 | Cold Room Insulation Detail 9..... 109  |
| A-11 | Cold Room Insulation Detail 10..... 110   |
| A-12 | Precast Concrete Single Tee Construction..... 111   |
| A-13 | Typical Underfloor Air Duct Heat System For<br>Slab-On-Ground Freezers..... 112                 |
| A-14 | Typical Underfloor Air Duct Heat System..... 113  |
| A-15 | Underfloor Air Duct Heat System Thru Wall Detail..... 114                                       |
| A-16 | Underfloor Warming System Detail..... 115   |
| A-17 | Typical Electric-Resistance Heating System For<br>Slab-On-Ground Freezers..... 116              |
| A-18 | Typical Ground Temperature Indicator Installation..... 117                                      |
| A-19 | Typical Cold Storage Door With Air Curtain..... 118   |
| A-20 | Typical Air Curtain Detail At Door Head..... 119  |
| A-21 | Typical Suspended Ceiling Panel/Wall Panel<br>Construction - 1..... 120                         |
| A-22 | Typical Suspended Ceiling Panel/Wall Panel<br>Construction - 2..... 121                         |
| A-23 | Typical Wall Curb..... 122  |
| A-24 | Typical Vinyl Moldings For Use On Interior<br>Wall Finishes..... 123                            |
| A-25 | Typical Fastener Detail And Vapor Barrier Penetration<br>At Masonry Wall/Roof Juncture..... 124 |
| A-26 | Typical Cooler Floor Insulation..... 125  |
| A-27 | Typical Freezer Floor Insulation..... 126   |
| A-28 | Typical Exterior Wall Panel/Roof Panel Construction... 127                                      |
| A-29 | Typical Wall Panel Construction - 1..... 128  |
| A-30 | Typical Wall Panel Construction - 2..... 129  |
| A-31 | Typical Prefabricated Insulated Building..... 130   |

## MIL-HDBK-1032/2

## TABLES

|   | <u>Page</u>   |
|---|---|
| 1 | Administrative and Supervisory Offices and Support Area             |
|   | Space Requirements..... 11  |
| 2 | Special Requirements for Covered Storage Buildings..... 20          |
| 3 | Truck and Rail Vehicle and Dock Heights..... 26                     |
| 4 | Dock Leveler Life (Years) Based on Impact Loading..... 34           |
| 5 | Building Bay Size Comparison..... 63                                |
| 6 | Required Clear Building Heights..... 66                             |
| 7 | Lighting Standards for Federal Supply Service                       |
|   | Distribution Facilities..... 71                                     |
| 8 | General Requirements for Hazardous Materials Storage Facilities. 79 |
| 9 | Pallet Storage Quantities for Cold Storage Warehouses..... 89       |
|   | REFERENCES..... 131   |
|   | GLOSSARY..... 137   |



MIL-HDBK-1032/2

## MIL-HDBK-1032/2

## Section 1: CRITERIA FOR COVERED STORAGE BUILDINGS

1.1 Scope. The criteria in this handbook covers the design requirements for covered storage facilities in Category Codes 431-10 (Cold Storage), 441-10 (General Warehouse Navy), 441-20 (Controlled Humidity Warehouse), 441-30 (Flammable/Hazardous Storehouse), and 441-35 (Shed Storage), or the combination of these Category Codes. These criteria address the factors which affect the functional effectiveness of covered storage facilities. Included in these factors are siting, system selection, facility layout, area, storage height, and internal details. Since modern storage facilities are integrated operations in which the structure and materials handling/ storage equipment function as a system, coordination of equipment and structure requirements is essential to proper operation of the system. The more common facility types required for naval shore activities include:

- a) Warehouses for hazardous materials, heavy materials, dehumidified storage, aviation, medical supplies, boxing, crating, and cold storage.
- b) Receiving, shipping, and issue buildings.
- c) Preservation buildings.

Certain Marine Corps expeditionary units require permanent warehousing facilities while in garrison. These Marine Corps facilities may include offices, an armory (in accordance with Department of Defense Storage and Materials Handling Manual, DOD 4145.19-R-1; and Physical Security and Loss Prevention Manual, OPNAVINST 5530.14 Series), and a camp maintenance workroom.

1.2 Cancellation. This handbook on covered storage, MIL-HDBK-1032/2, cancels and supersedes NAVFAC DM-32.02, Covered Storage, June 1982.

1.3 Related Criteria. The following criteria are related to the design of covered storage buildings:

1.3.1 DOD Construction Criteria. Refer to, and comply with, all pertinent criteria in Department of Defense Construction Criteria Manual, DOD 4270.1-M.

1.3.2 Requirements of Other Commands or Bureaus. Cold storage installations must meet specifications of the management or system command exercising control over them. General criteria of the management or system command are incorporated in the General Development Map of the activity. Specific requirements must be coordinated with the cognizant management or system command.

1.3.3 Facility Plates. As military handbooks and definitive drawings are revised, definitive drawings are being restructured to be included in the handbook which covers that type of building. These are included in the various handbooks manuals and are titled Facility Plates. The facility plate number is the category code number, and the sheets required to present the information are numbered sequentially.

## MIL-HDBK-1032/2

1.3.4 Definitive Drawings. Drawings contained in Definitive Designs for Naval Shore Facilities, NAVFAC P-272, Part 1, are an integral part of NAVFAC design policy and shall be used in conjunction with this publication.

1.3.5 Other Sources. All documents referenced in this military handbook are included in the REFERENCES.

1.4 Classification of Facility Groups. Major supply activities may be comprised of some or all of the facility codes listed below. For guidance in determining space allowances, see Facility Planning Criteria for Navy and Marine Corps Shore Installations, NAVFAC P-80, Sections 440A, 440B, and 440C (1985 Revision). Supply Facilities in Category Group 400 described in this manual include:

1.4.1 Cold Storage (Code 431-10). Cold storage warehousing is planned to satisfy the primary function of preservation of the quality of perishable foods and general supply materials that require refrigeration. The warehouse will include freeze and chill space, processing facilities, and mechanical areas.

1.4.1.1 Material Categories. Cold storage is planned to provide storage of General Supply Materials which require temperatures ranging from -10F to 60F (-23C to +16C) in the following categories:

- a) Perishable Subsistence
- b) Photosensitized Material
- c) General Supply Batteries
- d) Medical and Dental Supplies

1.4.1.2 Exclusions. Excluded from this Category Code is cold storage for weapons-related batteries (use Category Code 424-10) and cold storage spaces which are a functional part of another facility such as an open mess, club, hospital, commissary, or exchange. These latter cold storage spaces are planned as part of the main facility and must be accommodated within its space allowances.

1.4.2 General Warehouse Navy (Code 441-10). This Category Code includes general warehouses, heated or unheated, and with or without heavy duty lifting (overhead crane) capability, sprinkler systems, and alarm systems. The general warehouse provides space for bulk and bin storage, aisle space, receiving and shipping space, packing and crating space, and office and toilet space.

1.4.3 Controlled Humidity Warehouse (Code 441-20). A controlled humidity warehouse is similar to a general warehouse in every respect except that it is constructed with vapor barriers and contains humidity control equipment to maintain humidity at desired levels. This warehouse may be a separate building or contiguous with a general warehouse. Requirements for controlled humidity space must be thoroughly justified. Such requirements must be considered a portion of the total space allowed for Category Codes 441-10

## MIL-HDBK-1032/2

through 441-40. Planning for storage of material in controlled humidity space for varying periods of time is authorized when the use of such space performs the following:

- a) Permits technical material and material highly sensitive to moisture to be stored in a state of readiness for immediate issue.
- b) Permits a reduction in the cost in initial preservation or representation of material.
- c) Affords significant reduction in either the reactivation time or the reactivation cost of material, or both.
- d) Maintains the condition of any material being held in temporary storage while awaiting repair, disposition, preservation or representation, or assembly of components.
- e) Affords the desired supplemental protection to material already subjected to preservation treatment.

1.4.4 Flammable/Hazardous Storehouse (Code 441-30). Flammable/hazardous materials storehouses differ significantly from general warehouses due to the materials stored and the provisions made to prevent, and remove through proper ventilation, mists, gases, and vapors in accordance with National Fire Protection Association (NFPA) Flammable and Combustible Liquids Code, NFPA 30. Materials considered for storage in this category facility include paints, certain packaged petroleum/oil/lubricant (POL) materials, chemicals, acids, corrosive liquids, oxidizing materials, and other similar hazardous flammable materials. Space justified for flammable/hazardous storehouses must be considered a portion of the total space allowed for Category Codes 441-10 through 441-40. Such space should not exceed 5 percent of the total space unless thoroughly justified. Whenever practical, shed storage (see paragraph 1.4.5) should be justified and used. If necessary, the Naval Supply Systems Command (NAVSUP), Washington, DC, should be consulted for guidance. Such flammable and combustible liquid storehouse facilities must comply with the requirements of Section 4 of this handbook.

1.4.5 Shed Storage (Code 441-35). A shed is a roofed structure without complete side or end walls and with or without sprinklers or alarm systems. Sheds are typically used for storage of gas cylinders, drummed POL, vehicles, unfinished lumber, and other construction material. In areas where it is impractical to use shed space for the storage of materials because of weather conditions, storage requirements must be included as warehouse space and complete justification must be submitted. Sheds storing hazardous materials are subject to special design requirements. Comply with criteria in Section 4 of this handbook.

1.5 Storage Categories Not Addressed in This Handbook. The following storage categories are not addressed in this handbook:

1.5.1 Liquid Storage - Fuel and Nonpropellants (Code 410). Bulk tanks and associated equipment for liquid fuel storage and storage of liquids other than water, fuel, and propellants are not included. Refer to Petroleum Fuel Facilities, NAVFAC DM-22, for criteria regarding petroleum fuel facilities.

MIL-HDBK-1032/2

1.5.2 Ammunition Storage (Code 420). Magazines, specialized warehouses, tanks, and open pads for storage of ammunition, inert ammunition components, liquid propellants, and weapon related batteries are not included.

1.5.3 Open Storage (Code 450). Non-covered storage areas, paved or otherwise, established for storage of General Supply Materials are not included.

## MIL-HDBK-1032/2

## Section 2: PLANNING FACTORS

2.1 Geographic Location. Planning and design of covered storage facilities must address the specific climatic and geographic conditions of the intended site.

2.1.1 Tropical Regions. Refer to Tropical Engineering, MIL-HDBK-1011/1, for criteria regarding the design, construction, and maintenance of shore facilities in the tropics utilizing qualified materials, applications, and methods to overcome aggressive solar radiation, high humidity, salt spray, mildew, and termites.

2.1.2 Cold Regions. Refer to Arctic and Subarctic Construction, Technical Manual (TM) 5-852 Series, for criteria regarding construction in cold regions. Problems include permafrost, foundation design, extreme cold, draft control, and wind-driven snow.

2.1.3 Mountainous Areas. For mountainous regions, investigate site drainage, soil stability, site layout (grading), snow pack conditions, and wind.

2.1.4 Desert Areas. For desert regions, investigate intense solar radiation, high temperatures, site drainage (flash floods), and wind-driven sand.

2.1.5 Waterfront Areas. Refer to General Criteria for Waterfront Construction, NAVFAC DM-25.06, for criteria for waterfront construction. Specific factors to evaluate in design include salt water, water spray, corrosion, ice damage, foundations, and marine insect damage.

2.2 Site Planning. Overall layout of major storage activities or areas shall be as stipulated by the General Development Map of the activity. General planning considerations shall serve as the basis for establishing relationships between buildings and other facilities. Future expansion of all buildings shall be considered when developing the layout. Site facilities above, or protected from, a 500 year flood plane. Perform a Preliminary Environmental Assessment (PEA) in accordance with Environmental and Natural Resources Protection Manual, OPNAVINST 5090.1; and Real Property Facilities Manual, Volume 5 (Environmental Management), Marine Corps Order (MCO) 11000.8B. The PEA requires detailed assessment of hydrological, geological, and meteorological conditions. Also consider the following:

2.2.1 Vehicle Access. All covered storage buildings must be provided with access for trucks, materials handling apparatus, and fire apparatus. Truck parking and turning space must be provided.

2.2.2 Rail Access. Larger buildings must have rail access beside or inside them.

## MIL-HDBK-1032/2

2.2.3 Grading and Drainage. Check the following:

2.2.3.1 Groundwater. The designer shall determine variations in groundwater elevation and direction of groundwater flow. These data shall be used by the designer to evaluate the damage potential of a spill or release and to assure the design is adequate to prevent spills from contaminating surface and groundwater. Groundwater monitoring, sufficient to establish background levels, may be performed by the host installation.

2.2.3.2 Roof Drainage. Roof drainage shall be provided through underground piping or natural runoff.

2.2.3.3 Site Grading. Eliminate water pockets onsite through proper site grading.

2.2.3.4 Cut and Fill. Determine whether the building can be designed to reduce cut and fill.

2.2.4 Utilities. The source and location of all major utilities (water, electric, sewage, and steam), both above and below ground, must be known. The facility site should be selected so as to take advantage of direct access to needed utilities while preserving the expandability and maintainability of the utility system.

2.2.5 Security. Use criteria in Physical Security, MIL-HDBK-1013/1, as guidance to ensure that physical security considerations are included in the design of Naval shore facilities. Security factors include threat considerations and delay time and cost relationships to apply for appropriate and economical physical security at Naval shore facilities.

2.3 Storage/Handling System Selection. Functional concept planning for new facilities or modernization of existing facilities should include review of concepts presented in the Warehouse Modernization and Layout Planning Guide, NAVSUP PUB-529. Evaluation of alternative materials handling systems, selection of handling and storage equipment, design of operations, and layout of the building shall consider the following:

2.3.1 Design Parameters. The following design parameters shall be observed when collecting data and analyzing requirements:

2.3.1.1 Load Size. The standard Navy cargo load size (including pallet) is 40 inches x 48 inches x 36 inches high (1020 millimeters [mm] x 1220 mm x 915 mm), or 40 cubic feet (ft<sup>3</sup>) (1.13 cubic meters [mm<sup>3</sup>]) which is equal to 1 Measurement Ton (M/T). The average storage load is 0.8 M/Ts (32 ft<sup>3</sup>, 0.91 mm<sup>3</sup>) which equates to a pallet size 40 inches x 48 inches x 28.8 inches (1020 mm x 1220 mm x 730 mm). A 48-inch (1220 mm) vertical pallet rack beam spacing is provided by the standard pallet rack configuration for this average height load. Maximum DOD allowances for loaded pallets with overhanging loads is 43 inches x 52 inches (1090 mm x 1320 mm). Planning should accommodate such vertical dimensions or be adjusted where loads differ significantly from the average height. In special cases such as automated storage/retrieval system racks, it may be necessary to maintain the 40-inch x 48-inch (1020 mm x 1220 mm) dimensions due to equipment restrictions.

## MIL-HDBK-1032/2

2.3.1.2 Transaction Activity. Transaction activity is based on use of a 1348-1 order document.

2.3.1.3 Standards. Standard estimating factors for storage costs, handling costs, and handling times in NAVSUP PUB-529, are normalized to represent typical applications. Accuracy of these standards relative to actual performance of an activity must be evaluated before comparisons are made between proposed designs and current operations. Refer to Section 19 of NAVSUP PUB-529 for guidance in adjusting these factors.

2.3.1.4 Storage Height. Economical storage height is dictated by space availability, foundation cost, aviation restrictions, materials handling equipment availability, and storage requirements. These characteristics shall be considered when making system evaluations. Hazardous materials warehouses are limited to a maximum storage height of 25 feet (7620 mm) or less, depending upon the type of materials handling equipment used. See paragraph 4.3.2.

2.3.2 Procedures. The following steps should be followed in developing a facility concept using NAVSUP PUB-529 procedures. Figure 1 illustrates these steps in flowchart form. Refer to Sections 14-17 of NAVSUP PUB-529 for details. The Activity or Project Manager shall designate in the project scope the following factors, as well as any special requirements for storage or handling.

2.3.2.1 Define Inventory. State inventory levels in terms of 0.80 Measurement Ton (M/T) pallet loads (32 ft<sup>3</sup> or 0.91 m<sup>3</sup>) or 0.0095 M/T (0.38 cubic foot; 0.011 cu. m) shelf boxes. Separate inventory into groups with similar storage, handling, or transaction characteristics. Examples are pallet storage, bin storage, high and low activity material, Pre-Positioned War Reserve Stocks, etc.

2.3.2.2 Define Daily Transactions. Define daily activity levels for pallet systems in terms of daily quantities of pallets stored and retrieved. Define daily activity for binnables and rackables order picking systems in line item document issues.

2.3.2.3 Define Available Area. Define the area available for system installation for both new facility designs and conversion of existing facilities.

2.3.2.4 Compute Transaction/Inventory (T/I) Ratio. Compute the system T/I ratio based upon the defined inventory and transaction quantities. Develop separate T/I ratios for each inventory or handling group identified by the procedure in sub-subparagraph 2.3.2.1.

2.3.2.5 Select System. Evaluate and select alternative systems based on the computed T/I ratios.

2.3.2.6 Determine Cost. Determine the relative system cost for each alternative system and select the least cost system.



MIL-HDBK-1032/2

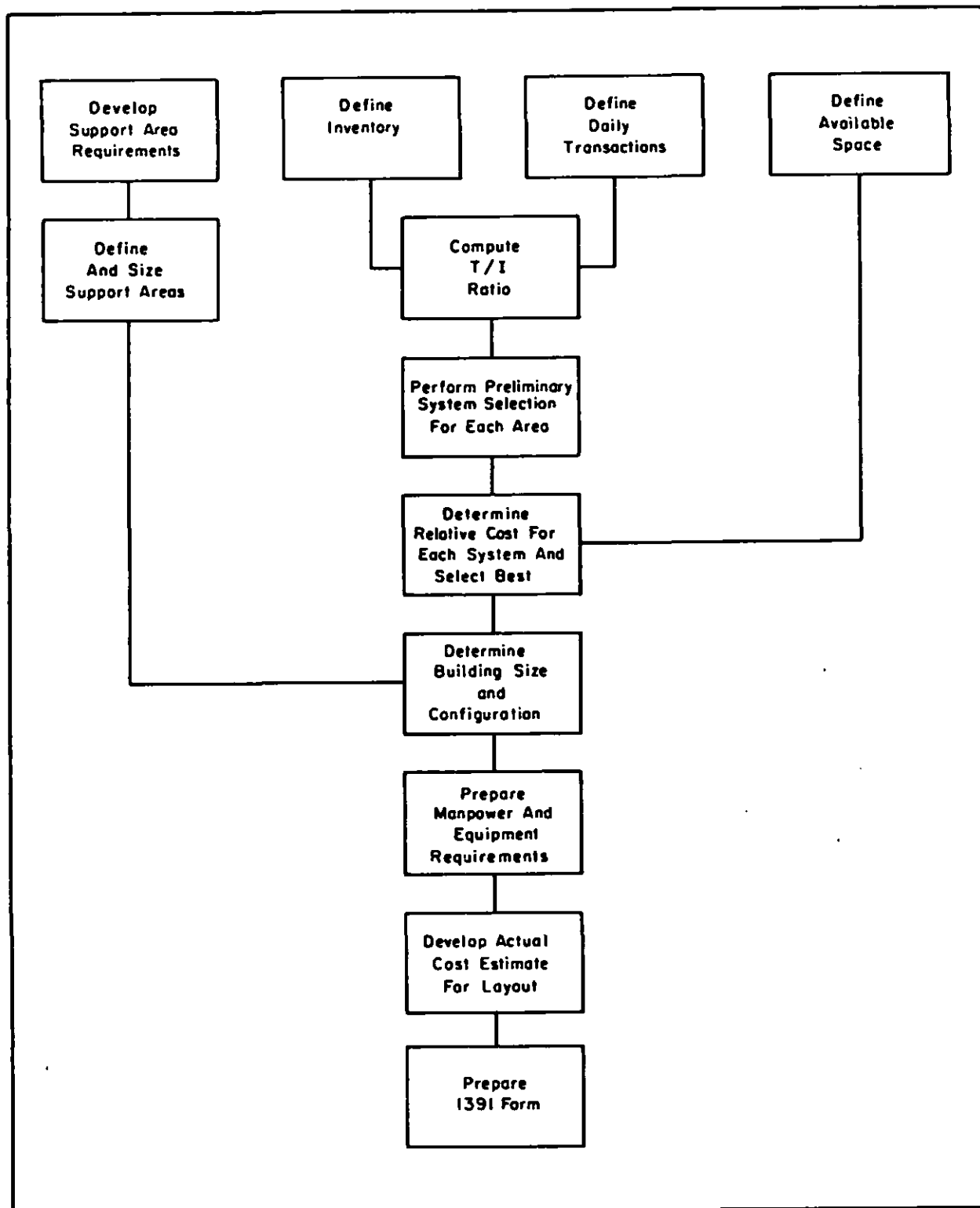

Figure 1  
System Selection Flowchart

## MIL-HDBK-1032/2

2.3.2.7 Determine Area. Determine the required building area for the selected system(s). Include cube and stacking height values as per Shore Facilities Planning, NAVFACINST 11010.44d; and Facility Planning Criteria for Navy and Marine Corps Installations, NAVFAC P-80, Section 440-C.

2.3.2.8 Determine Support Requirements. Evaluate and size support areas.

2.3.2.9 Integrate Layout. Develop a composite building layout by integrating the various storage and support areas into a facility layout. Hazardous materials storage areas must be isolated in combination layouts.

2.3.3 Materials Handling Equipment. The following materials handling equipment are essential components of covered storage facilities and their characteristics must be considered during the design phase.

2.3.3.1 Pallet Handling Equipment. This equipment may be either vehicular (truck-like) or specifically designed (i.e., storage/retrieval machine) for transporting and storing the standard Navy pallet. Refer to NAVSUP PUB-529 for descriptions of available equipment.

2.3.3.2 Order Picking Equipment. This equipment is designed to aid a worker in the selection and transportation of supplies and may be vehicle based or designed as an application specific piece of equipment.

2.3.3.3 Transport Systems. These systems are designed for the movement of supplies between two or more locations within or outside of a facility. They may be designed to transport packaged loads (pallets or shelf boxes), loose loads, bulk liquids, or solids.

2.3.4 Storage Equipment. The following types of storage equipment are essential components of covered storage facilities and their characteristics must be considered during the design phase.

2.3.4.1 Pallet Rack. Pallet racks shall be designed for safe storage of palletized loads based on the standard Navy pallet. Designs for other size pallets may be used in concurrence with NAVSUP. Refer to Section 6 of NAVSUP PUB-529 and NAVSUP specifications for pallet rack for related criteria.

2.3.4.2 Shelving/Bins. Shelving and bins are designed for storage of package type items in less than pallet load quantities. Refer to Section 5 of NAVSUP PUB-529 for shelving/bin characteristics.

2.3.4.3 Special. Special storage equipment consists of devices designed for specific purposes such as cantilever rack, vertical sheet storage rack, pallet stacking frames, rigid and collapsible metal bins, etc.

2.3.4.4 Installation and Operation Tolerances. Observe the following tolerances for installation and operation of storage equipment. These tolerances apply in the absence of more stringent manufacturer tolerances.

a) Plumbness of pallet racks and high rise shelving  $\pm 1/16$  inch ( $\pm 1.6$  mm) over total height.

## MIL-HDBK-1032/2

- b) Pallet rack beam elevation  $\pm 1/4$  inch ( $\pm 6.4$  mm) between adjacent beams.
- c) Rail guide position  $\pm 1/4$ ,  $-0$  inches ( $\pm 6.4$  mm,  $-0$  mm) from specified rail spacing.
- d) Wire guide position  $\pm 1/4$  inch ( $\pm 6.4$  mm) from specified centerline.
- e) Pallet rack aisle spacing  $\pm 1/4$  inch ( $\pm 6.4$  mm) from design aisle width.
- f) Down-aisle rack offset  $\pm 1/4$  inch ( $\pm 6.4$  mm) from aisle centerline.

2.4 System Considerations. Consider the following system factors when planning or revising materials handling systems:

2.4.1 Receiving/Shipping Operations. Review vehicle and material flow characteristics, including:

- a) Types of vehicles to be serviced.
- b) Location of rail and road access.
- c) Location with respect to other facility operations.
- d) Support area requirements, such as staging areas and offices.

2.4.2 Order Picking Operations. Review load and documentation requirements, including:

- a) Type of product being processed.
- b) Documentation requirements.
- c) Packing/packaging requirements.

2.4.3 Support Areas. Separate support areas from hazardous materials storage areas with a 2-hour fire wall and from combustible or flammable storage areas with a 4-hour fire wall. Direct access between support areas and hazardous materials storage areas is not permitted. Refer to Table 1 for space estimating criteria for administrative and supervisory offices. Refer to NAVFAC P-80 and Appendix B of NAVSUP PUB-529 for criteria relating to other warehouse support functions. Areas considered for support of a storage facility should include the following:

2.4.3.1 Supervisory Offices. Provide offices for supervisory personnel such as foremen, crew leaders, etc. Offices shall accommodate two people and provide filing space, one desk, and two chairs per person. Offices shall be located near their associated activity areas. Offices may consist of prefabricated partition-type enclosures or more permanent forms of construction such as concrete block.

Separate shipping and receiving office areas may be required in larger facilities and combined hazardous/flammables and general storage facilities for safe operation and to expedite the flow of paperwork associated with the increased activity. A facility with few employees may use a single multipurpose office located away from any hazardous/flammables storage area. Office location and arrangement shall provide separation of work functions and maintain security by controlling access to the facility by outsiders. Offices

## MIL-HDBK-1032/2

Table 1  
Administrative and Supervisory Offices and  
Support Area Space Requirements

| LOCATION                | LENGTH |        | WIDTH |       | AREA            |                   |
|-------------------------|--------|--------|-------|-------|-----------------|-------------------|
|                         | ft.    | (m)    | ft.   | (m)   | ft <sup>2</sup> | (m <sup>2</sup> ) |
| Private Offices         |        |        |       |       |                 |                   |
| Warehouses Manager      | 20     | ( 6.1) | 16    | (4.9) | 320             | ( 29.7)           |
| Personnel Manager       | 14     | ( 4.3) | 12    | (3.7) | 168             | ( 15.6)           |
| Open Office Dividers    |        |        |       |       |                 |                   |
| Managers                | 12     | ( 3.7) | 12    | (3.7) | 144             | ( 13.4)           |
| Assistants              | 10     | ( 3.0) | 8     | (2.4) | 80              | ( 7.4)            |
| Secretaries             | 8      | ( 2.4) | 8     | (2.4) | 64              | ( 5.9)            |
| Accounts Payable        | 5      | ( 1.5) | 7     | (2.1) | 35              | ( 3.3)            |
| Inventory Control       | 5      | ( 1.5) | 7     | (2.1) | 55              | ( 3.3)            |
| Procurement             | 6      | ( 1.8) | 8     | (2.4) | 48              | ( 4.5)            |
| Operations              | 6      | ( 1.8) | 6     | (1.8) | 36              | ( 3.3)            |
| Meeting Area            | 10     | ( 3.0) | 10    | (3.0) | 100             | ( 9.3)            |
| Interview Area          | 8      | ( 2.4) | 8     | (2.4) | 64              | ( 5.9)            |
| Programmers             | 8      | ( 2.4) | 8     | (2.4) | 64              | ( 5.9)            |
| Open Support Services   |        |        |       |       |                 |                   |
| Files                   | 1      | ( 0.3) | 5     | (1.5) | 5               | ( 0.5)            |
| Reception/Lobby Area    | 30     | ( 9.1) | 20    | (6.1) | 600             | ( 55.7)           |
| Main Aisles (1)         | --     | --     | --    | --    | --              | --                |
| Secondary Aisles (2)    | --     | --     | --    | --    | --              | --                |
| Photocopy Machine       | 6      | ( 1.8) | 4     | (1.2) | 24              | ( 2.2)            |
| Closed Support Services |        |        |       |       |                 |                   |
| Mail Room               | 25     | ( 7.6) | 12    | (3.7) | 300             | ( 27.9)           |
| Restrooms (1 each)      | 24     | ( 7.3) | 8     | (2.4) | 192             | ( 17.8)           |
| Janitorial Closet       | 6      | ( 1.8) | 4     | (1.2) | 24              | ( 2.2)            |
| Clothes Closet          | 10     | ( 3.0) | 2     | (0.6) | 20              | ( 1.8)            |
| Supply Room             | 18     | ( 5.5) | 12    | (3.7) | 216             | ( 20.1)           |
| Computer Room           | 25     | ( 7.6) | 20    | (6.1) | 500             | ( 46.5)           |
| Conference Room         | 25     | ( 7.6) | 20    | (6.1) | 500             | ( 46.5)           |
| Lunch/Break Room (3)    | 60     | (18.3) | 20    | (6.1) | 1200            | (111.5)           |
| First-Aid Room          | 16     | ( 4.9) | 12    | (3.7) | 192             | ( 17.8)           |

## Notes:

- (1) Estimated at 25% of Private Office/Open Office Divider area.
- (2) Estimated at 30% of floor area for Open Office Divider areas.
- (3) Size estimate for 50 employees.

## MIL-HDBK-1032/2

shall permit an unobstructed view of the inside and outside dock areas. Rest room facilities for both truck drivers and employees may be integrated into the office design.

2.4.3.2 Receiving Office. The typical receiving office illustrated in Figure 2 provides space for a building and site security system and office space for receiving personnel. The secured entrance, lobby and rest room for truck drivers, provides controlled entry into the facility. Separate rest rooms are provided for supervisory and warehouse personnel.

2.4.3.3 Shipping Office. The typical shipping office illustrated in Figure 3 provides a separate entrance, lobby, and rest room for truck drivers. A central office area and separate rest room facilities are provided for shipping department and supervisory personnel.

2.4.3.4 Rest Rooms. Separate rest room facilities may be provided for supervisory and general warehouse personnel. Fixture allowances shall be in accordance with the NAVFAC Mechanical Engineering Criteria Manuals and DOD 4270.1-M.

2.4.3.5 Employee Services. Employee service areas consist of break rooms, canteen and vending machine facilities, and locker rooms. Size these areas to accommodate the expected number of employees. Multiple installations may be required to place these facilities within required distances from employee activity areas. Refer to the NAVFAC Architecture Criteria Manuals; Plumbing Systems, NAVFAC DM-3.01; and DOD 4270.1-M for specific requirements.

2.4.3.6 Crating Operations. General purpose storage facilities may require crating of large or odd shaped items prior to storage or shipment. Variability in requirements for materials, product size, and tools necessitates individual design of crating areas. Refer to Packaging of Materiel, Preservation, NAVSUP PUB-502; Packaging of Materiel, Packing, NAVSUP PUB-503; and NAVSUP PUB-529 for criteria.

2.4.3.7 Packing/Packaging Operations. Requirements for small item packaging may be met through use of multipurpose packing table work stations. Small item packaging must support a supply of cartons, filler material, tape, glue, labels, and scales. The design of small item packing operations must be approached on an individual facility basis. Refer to NAVSUP PUB-502, Preservation and Packing; NAVSUP PUB-503, Packing; and NAVSUP PUB-529 for criteria. Repackaging of damaged hazardous materials packages must be performed in a designated safe area.

2.4.4 Parking. Provide parking space for all facility employees within walking distance of the facility entrance. Parking areas shall be separated from truck docks and other activity areas by fences. Site security shall be enforced by separating the storage facility from the remainder of the activity and further isolating parking from receiving and shipping functions. Refer to DOD 4270.1-M for parking requirements.

MIL-HDBK-1032/2

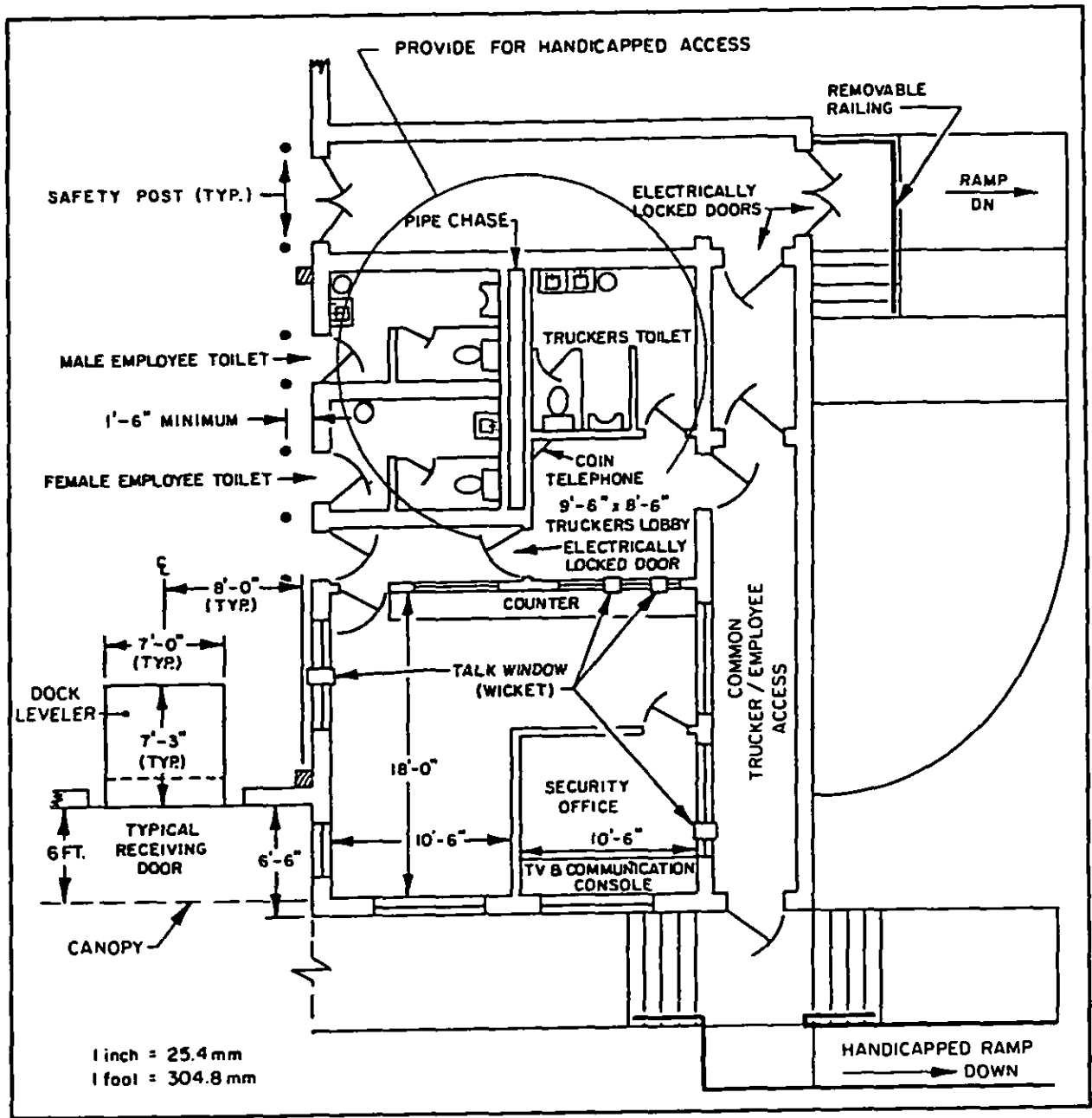

Figure 2  
Typical Receiving Office (Functional Dimensions)

MIL-HDBK-1032/2

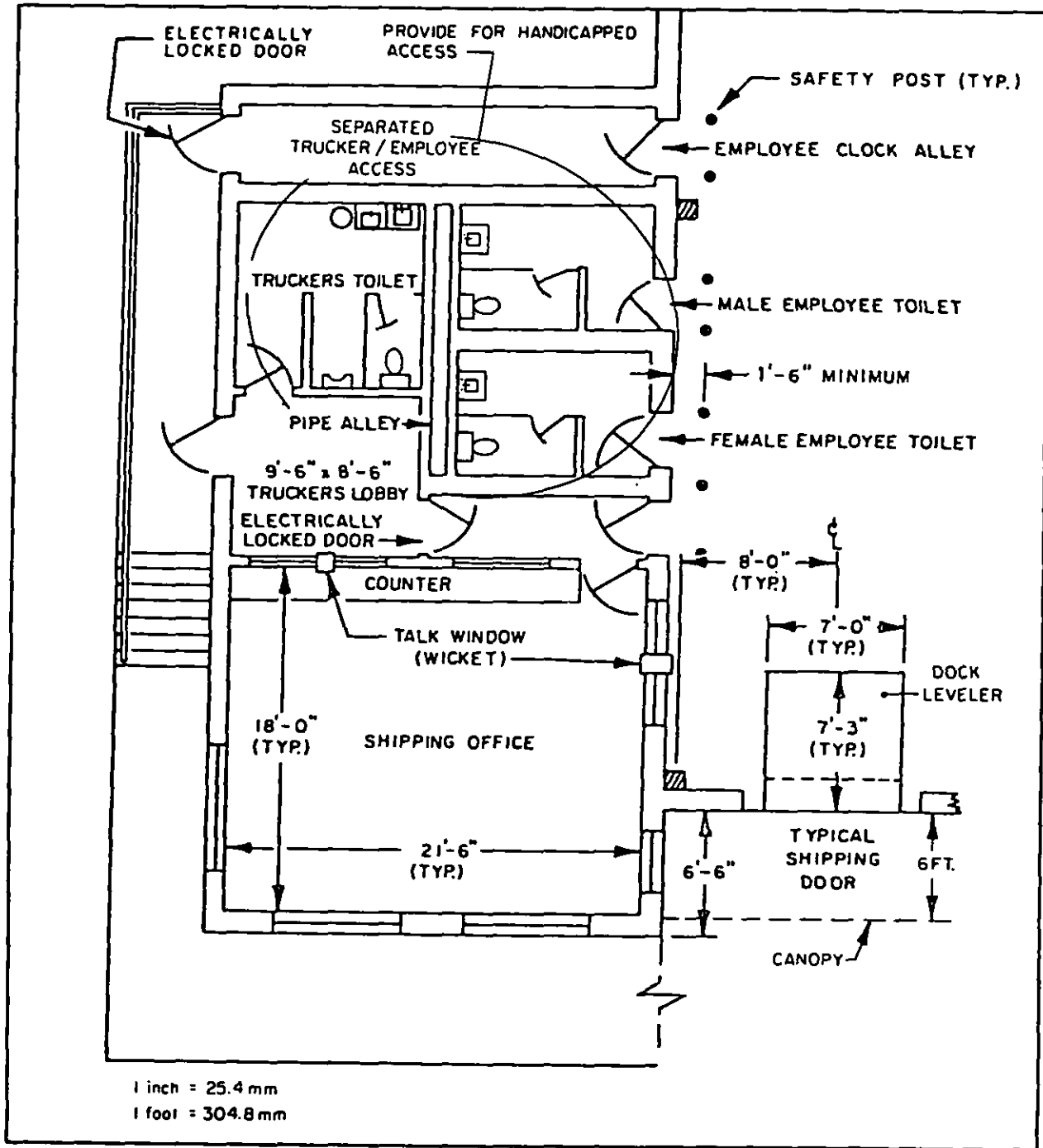

Figure 3  
Typical Shipping Office (Functional Dimensions)

## MIL-HDBK-1032/2

2.4.5 Traffic Flow. Arrangement of the facility on the site and internal arrangement of the operating systems shall be evaluated to reduce or eliminate areas of conflicting traffic. Consider interaction with base traffic flow.

2.4.6 Safety. Provide safety markings on walls and floors. Define areas for fork-truck battery charging and refueling. Provide fire protection equipment (fire hoses, portable extinguishers, standpipes, etc.). Provide specialized safety equipment (eye wash/shower, spill lockers, etc.) in hazardous materials areas. Provide all additional safety features required by the Occupational Safety and Health Administration (OSHA), in accordance with Title 29 Code of Federal Regulations (CFR) Part 1910, Occupational Safety and Health Standards.

2.5 System Costs. Several alternative systems may be feasible to satisfy a given storage requirement. Each alternative under consideration must be considered in terms of its full life-cycle total funding implications regardless of funding source, as well as its benefits. Selected equipment shall be identified, evaluated, and priced as early as practical. Timing of costs and savings is an essential factor in economic analysis. Include only those costs and cash flows which the decision can affect. Refer to the Economic Analysis Handbook, NAVFAC P-442, for procedures and analysis presentation format.

2.5.1 Investment Cost. Investment cost includes some or all of the following costs associated with development of alternatives. Net total investment is the algebraic sum (plus and minus) of the dollar amounts of the one-time cost elements in subparagraphs 2.5.1.1 to 2.5.1.6. In the event these costs do not occur during the project base year (Time Zero), convert all costs to their equivalent present value costs for the project base year.

2.5.1.1 Research and Development. Include all research and development costs incurred after the decision point.

2.5.1.2 Facility Investment. Include all costs associated with the acquisition of equipment, real property, nonrecurring services, nonrecurring operation and maintenance (startup) costs, and other one-time investment costs. If investment costs may be spread over several years, the year(s) must be identified.

2.5.1.3 Working Capital Changes. Working capital changes can be positive, representing additional funding requirements, or negative, representing a reduction in funding requirements.

2.5.1.4 Value of Existing Assets Employed. The value of existing assets (already onhand) shall be included in the investment cost only when one of the two following conditions is met:

a) When the use of the existing asset will result in a cash outlay on some other project which would otherwise not be incurred; i.e., when the existing asset is currently in use (or has an alternative planned use) on some other project.



## MIL-HDBK-1032/2

b) When the use of the existing asset will deprive the Government of cash planned to be realized by sale.

In all other cases, the value of existing assets employed will be treated as expenses incurred prior to the decision point and will not affect the analysis. Existing assets shall be included at their fair market value. The basis for arriving at the estimate shall be fully documented.

2.5.1.5 Value of Existing Assets Replaced. The value of assets or property already onhand, the current need for which is eliminated by a proposed project, shall be deducted from investment cost if, and only if, there is a documented alternative use for the assets.

2.5.1.6 Terminal Value. The terminal value of a project is the estimated value of the proposed investment at the end of its economic life. Terminal value is impacted by such factors as the probability of continued need for the asset for Government or private use, appreciation, and depreciation (physical and functional).

2.5.2 Recurring Costs. Recurring costs are annual costs associated with operation of the facilities and consist of personnel costs, operating costs, and other annual costs.

2.5.2.1 Personnel Cost. All costs of civilian and military personnel and employee benefits.

2.5.2.2 Operating Cost. All operating costs, other than labor. Include materials, supplies, utilities, other services, maintenance, repair, support, and overhead costs.

2.5.2.3 Other. All recurring annual costs which do not fit into the above categories.

2.5.3 Life-Cycle Cost. Life-cycle cost in an economic analysis is the total cost to the Government of acquisition and ownership of an alternative system over its full life. It includes the investment and recurring costs of subparagraphs 2.5.1 and 2.5.2 and emphasizes the timing of costs and savings.

2.6 Technical Approval. Figure 4 illustrates the administrative steps that a project must follow. Technical review and approval of functional plans and specifications prior to and at the 35 percent design stage by the Naval Supply Systems Command (NAVSUP) Navy Warehouse Utilization Program is required in consonance with Storage and Warehousing Facilities and Services, NAVSUPINST 4450.21 Series. Coordination of system and facility layout and material flow patterns with architectural design is critical to completion of a functional facility. The Navy Energy and Environmental Support Activity shall be included in the review of Navy Occupational Safety and Health funded hazardous material storage facilities.

2.6.1 Layout And Flow Concept. Facility aspects dealing with system layout and material flow shall be coordinated and reviewed with NAVSUP Navy Warehouse Utilization Program for compliance with operational requirements.

MIL-HDBK-1032/2

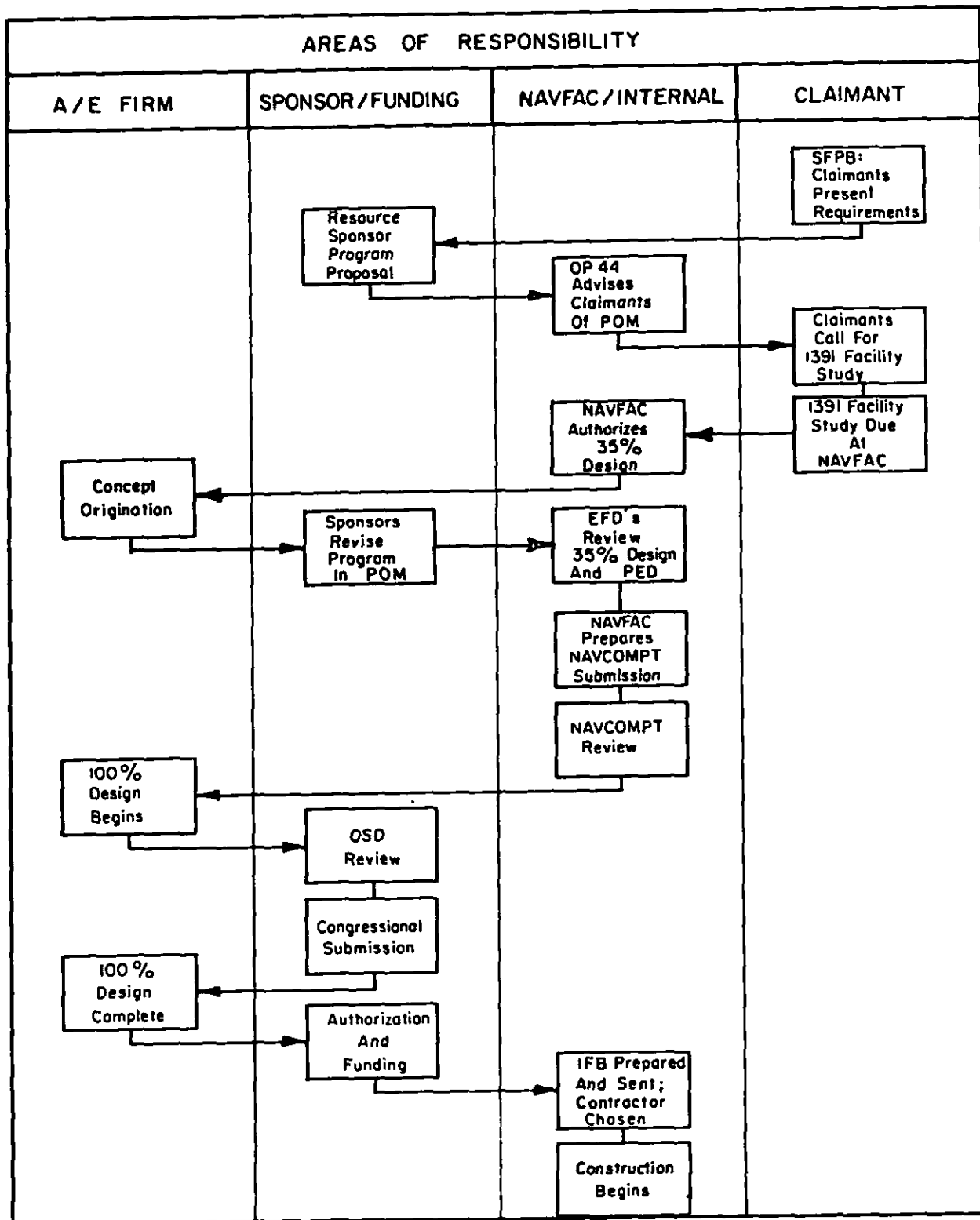

Figure 4  
Facility Design Process Flowchart

MIL-HDBK-1032/2

2.6.2 Architectural Design. Architectural design aspects of the facility shall be reviewed by NAVFAC and the Engineer-In-Charge (EIC) who is responsible for management of the Architect/Engineer (A/E) design contract.

2.7 Computer Design Aids. An interactive system selection model (CM-529), based on NAVSUP PUB-529 procedures, has been developed by the David W. Taylor Naval Ship Research and Development Center (DTNSRDC) to facilitate use of NAVSUP PUB-529. CM-529 displays the least cost system and storage height that satisfies specified criteria. It also displays the least cost system at all applicable storage heights. The user can then examine all systems at a specified height regardless of system cost. The selection of a system to meet the specified requirements is under the control of the user who can make a selection considering unique requirements that cannot be specified in the model. This aid is available through NAVSUP Navy Warehouse Utilization Program.

## MIL-HDBK-1032/2

## Section 3: BUILDING REQUIREMENTS

3.1 General Design Factors. Providing easy and rapid materials handling and maximum clear storage space are the prime considerations in warehouse design. Refer to NAVFAC P-272, drawings 1404209, 1404210, 1404211, 1404212, 1404516, and 1404517, for typical configurations. Section 3 provides criteria applicable to all storage facility classes.

3.1.1 Materials Movement. Transport paths and building layout shall avoid discontinuities and elevation changes which impede material movement and the integrity of the separation between flammable/hazardous materials storage and general storage. Locate covered storage facilities on a site to take advantage of highway and rail facilities. Evaluate location of the facility on the site to reduce or eliminate areas of conflicting traffic.

3.1.2 Expansion Capability. Consider present and future requirements in building construction and site location to permit future expansion of facilities in an orderly, safe, and cost-efficient manner.

3.1.3 Flexibility of Design. Where facility usage is uncertain or subject to change, building design shall use the universal bay dimension of 33 feet-0 inches x 64 feet-0 inches (10 060 mm x 19 510 mm).

3.1.4 Requirements of Specific Buildings. Building requirements are dictated by the function of the facility. Refer to Table 2 for general requirements for specific types of buildings. Hazardous materials storage facilities have specific requirements addressed in Section 4.

3.2 Building Shape and Proportions. Observe the following cautions relating to building size and shape:

3.2.1 Travel Distance. Arrange buildings or increments of buildings for minimum distance between high activity operations. Square buildings minimize perimeter wall area for a given floor area. Aspect ratios (ratio of length to width) of 1.25 or less are considered square. If possible, avoid aspect ratios exceeding 3.00 for conventional warehousing operations.

3.2.2 Irregular Shapes. Avoid irregular shapes, such as U or L.

3.2.3 Height. High-rise storage is preferred over low height buildings on a life-cycle cost basis since storage costs per unit stored, over the life of the project, decrease as height is increased. Coordinate building height parameters with storage system characteristics, as illustrated in Figure 5.

3.2.4 Area. Limit building size based only on restrictions due to loss potential and fire and hazardous chemicals safety. For criteria on area limitations, refer to subparagraph 3.7.4.

Table 2  
Special Requirements for Covered Storage Buildings

| BUILDING TYPE                           | FUNCTIONS   | SPECIAL REQUIREMENTS  |
|---|---|---|
| General Warehouse                       | All purpose structure for storing and handling supplies not requiring special considerations.   | Fire protection separation between buildings; Refer to MIL-HDBK-1008 for required building separation based upon construction and exposure. Provide separation of 120 ft. (36.6 m) between truck dock and any obstructions or buildings.  |
| Navy Materials Warehouse                | Storing and handling heavy and bulky supplies incapable of being handled by forklift trucks, but which may be handled more economically by overhead traveling cranes. | Overhead electrical traveling cranes to handle loads too heavy or bulky to be handled by forklift trucks. Elimination of fire walls because of interference with operation of overhead traveling cranes. Railroad service tracks within building. Flooring elevations at same level as top of inside railroad tracks. Doors for truck entry into building and truck entrances at floor level. Ventilation: continuous ridge ventilators in unheated and non-humidified buildings only. Heating: storage areas are not heated. |
| Aeronautical Materials Warehouse        | Storage of spare parts and component assemblies of aircraft.  | Truck and rail access. High, clear storage space and large doors. Overhead traveling cranes. Heating required only for personnel comfort. Dehumidification required. Bins or storage shelves.   |
| Flammable/Hazardous Materials Warehouse | Storage and handling of hazardous chemicals and highly combustible materials.   | Floor: 6 in. (150 mm) below the floor elevation of outside platforms or provide floor trenches for spill control. Flat floor with no drains or slope. Chemical resistant floor coating. Outside drainage with valve. Corrosive materials storage areas with external access doors. Ventilation: Continuous mechanical from floor and roof; minimum of 6 air changes per hour.   |
| Dehumidified Warehouse                  | Preserving of stores at maximum relative humidity of 40 percent.  | Proper equipment for dehumidifying. Additional electrical requirements. Measures to effectively seal openings.  |
| Medical Warehouse                       | Storage of medical supplies:<br>1. Small auxiliary facility for hospital or dispensary.<br>2. Large medical supply warehouse.   | Diversified functional elements include: Refrigeration, dehumidification, narcotics vaults, and heated spaces. Small facility is located and designed to best fit in local needs and support the parent structure. Large supply warehouse is a large building designed to meet present and foreseeable needs over wide areas for specified periods and situations.  |

Table 2  
Special Requirements for Covered Storage Buildings (Continued)

|   |   |   |
|---|---|---|
| Receiving, Shipping and Issue Buildings | Receiving: central point for receipt of shipments.<br>Shipping: central point for outloading.<br>Issue: standard storage buildings arranged for issuing supplies. | Based on the needs for receipt, unpackaging, inspecting, sorting, assembling, storage, repackaging, issue, reshipment, and other necessary handling. Special interior arrangements to carry out its mission and possibly special outloading facilities and techniques.<br><br>Provisions for local issue are met by special interior layout, such as in packaging and sorting space, assembly space, inspection, bins, counters, enclosures, space for item accounting, and provisions for personnel traffic. Requirements are determined largely by the characteristics of the using agency. |
| Receiving, Shipping and Issue Buildings | Receiving: central point for receipt of shipments.<br>Shipping: central point for outloading.<br>Issue: standard storage buildings arranged for issuing supplies. | Based on the needs for receipt, unpackaging, inspecting, sorting, assembling, storage, repackaging, issue, reshipment, and other necessary handling. Special interior arrangements to carry out its mission and possibly special outloading facilities and techniques.  |
| Miscellaneous Facilities                | Bulk Storage bins: storage of large lots of loose, solid materials.<br>Warehouse bins: provide additional storage space in warehouse buildings.                   | Varying, depending on the needs of the installation and materials to be contained. Materials, shape, and size determined by local needs. Arrange in double rows, back to back, and at right angles to main aisles: single rows may be arranged against walls. Passageways between open faces of bins should be a minimum of 36 in. (915 mm) wide. Metal units: width, 36 in. (915 mm); height, 7 ft. 3 in. (2.51 m); depth, 18 in. (460 mm).  |
| Boxing and Crating Buildings            | Boxing and crating material.  | One portion of building outfitted for necessary industrial operations; another portion for processing depot supplies; and the remainder devoted to storage of manufacturing stocks and assembled units.   |
| Preservation Buildings                  | Special operations for preserving supplies.   | Special equipment and facilities for preserving supplies before being placed in storage.  |
| Cold Storage                            | Preserving stores in controlled climate ranging from -5° F (-21° F) to 50° F (10° C).   | Proper equipment for cooling. Additional electrical requirements. Measures to effectively seal openings. Additional insulation requirements. Maximum utilization for storage space.   |

MIL-HDBK-1032/2

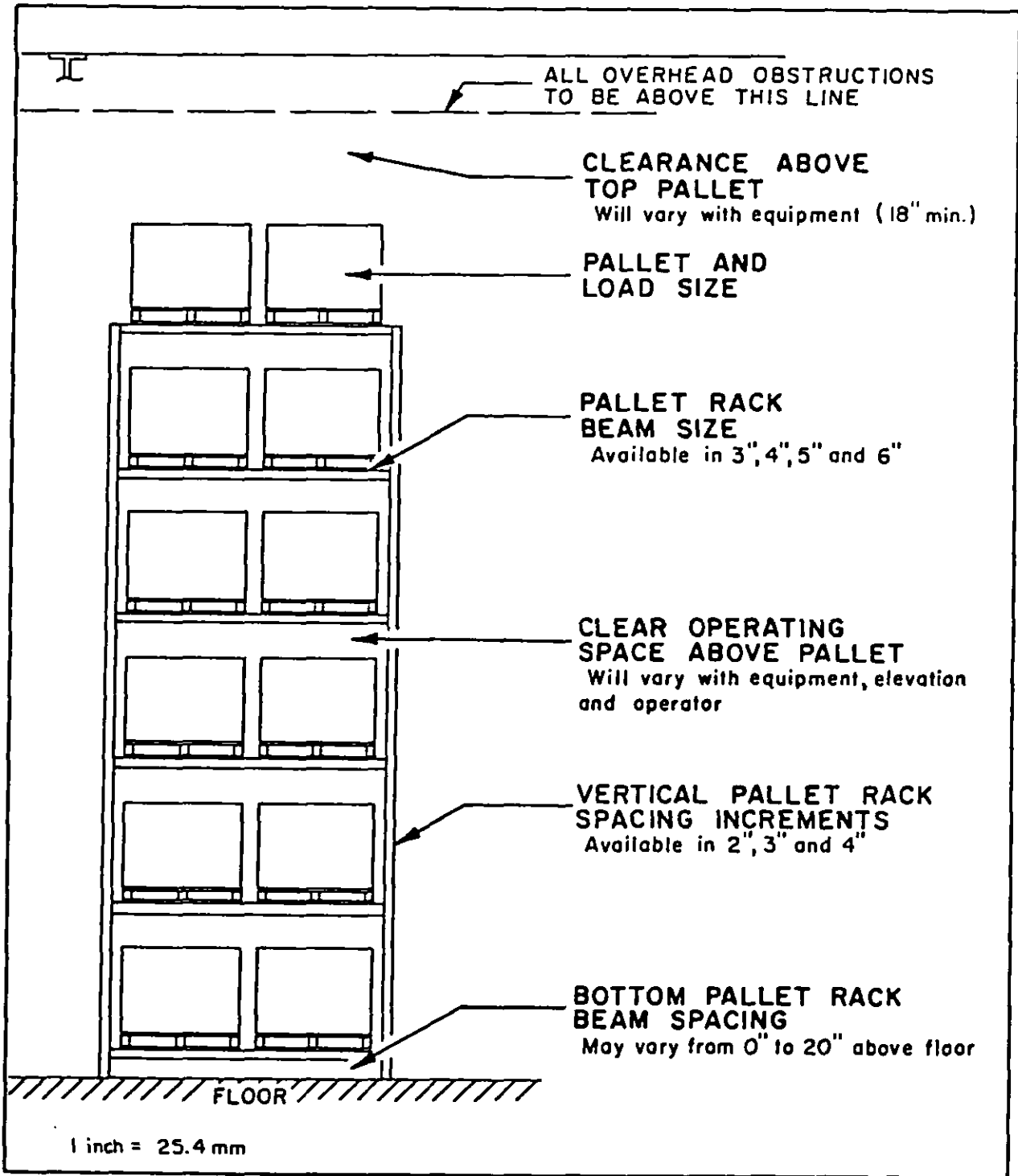

Figure 5  
Building Elevation Parameters

## MIL-HDBK-1032/2

3.3 Building Spacing. Required spacing between buildings to facilitate operations and aid in fire prevention, protection, and hazardous chemical spills (liquid/gas) control, will vary according to the type of construction and exposure classification. Refer to Department of Defense Military Handbook, Fire Protection for Facility Engineering, Design, and Construction, DOD MIL-HDBK-1008, for case specific requirements. Otherwise, observe the following:

3.3.1 Rail Side. Allow 120 feet (36.6 meters [m]) between faces of walls.

3.3.2 Truck Side. Allow 175 feet (53.3 m) between faces of walls.

3.3.3 Warehouses In-Line. Allow 30 feet to 150 feet (9.1 m to 45.7 m) between faces of walls.

3.3.4 Flammable/Hazardous Materials Facilities. Provide a 50-foot (15.2 m) buffer zone between the facility and the nearest inhabited area, stream, or body of water.

3.4 Docking Facilities. Provide maneuvering space to facilitate loading and unloading operations at warehouse rail and truck docks (see Figure 6). For information on overall tractor-trailer lengths, necessary turning radii for such units, and required apron space and clearances, refer to NAVSUP PUB-529. All docks and platforms shall be protected by full width canopies. Protect building corners and dock areas from vehicle impact by using concrete-filled steel pipes (see Figure 7). Dock areas in hazardous materials facilities must provide a manually operated valve in the outside drain trench to prevent spills from entering the storm sewer system. The drain shall discharge into a sump sized to accommodate the expected quantity of discharge.

3.4.1 Truck Docks. Truck dock height will vary between 44 and 52 inches (1120 mm and 1320 mm) depending on the class of trucks served (see Table 3). Use a 48-inch (1220 mm) height for general highway tractor-trailer service. Configure truck docks to conform to building, site, and traffic flow requirements (see Figure 8). Figures 9 and 10 show a typical dock. Use adjustable dockboards to adjust for variable bed heights and spring deflection. Slope dock apron areas away from the building, as illustrated in Figure 11. Provide doors of a size consistent with truck characteristics, as shown in Figure 12. Exterior truck platforms are not recommended.

Provide space to load and unload flatbed and low-boy trucks and to move material in and out of the warehouse using a rolling A-Frame hoist or similar material handling equipment. A dock adjacent to the ramp of the building may be equipped with a 5-ton (4500 kilogram [kg]) monorail, interrupted at the door with a moveable (swing) section. A 12 x 12 foot (3660 mm x 3660 mm) door shall be specified with this option. All outside supports shall have protective barriers.



MIL-HDBK-1032/2

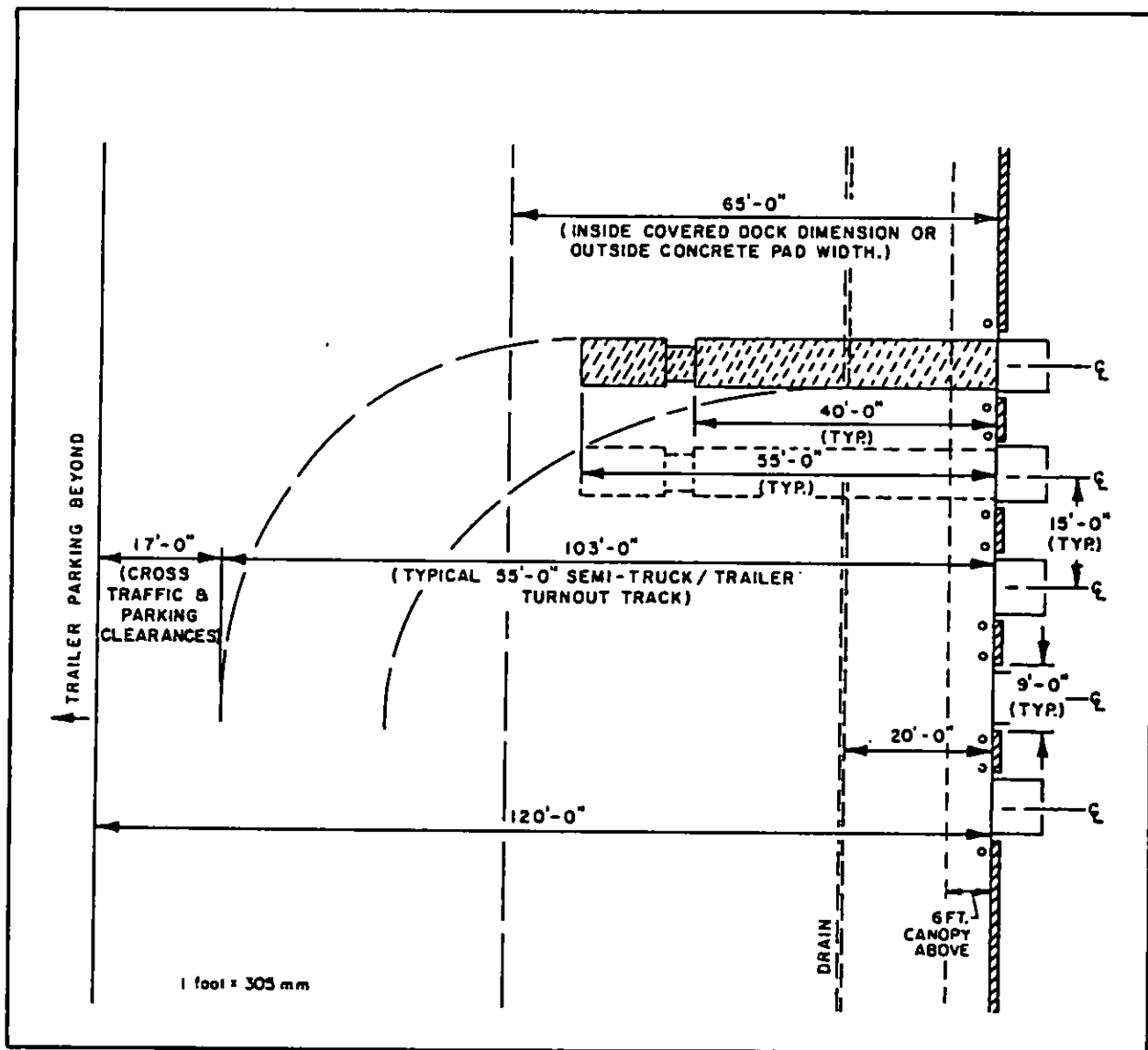

Figure 6  
Truck Apron Criteria (Functional Dimensions)

MIL-HDBK-1032/2

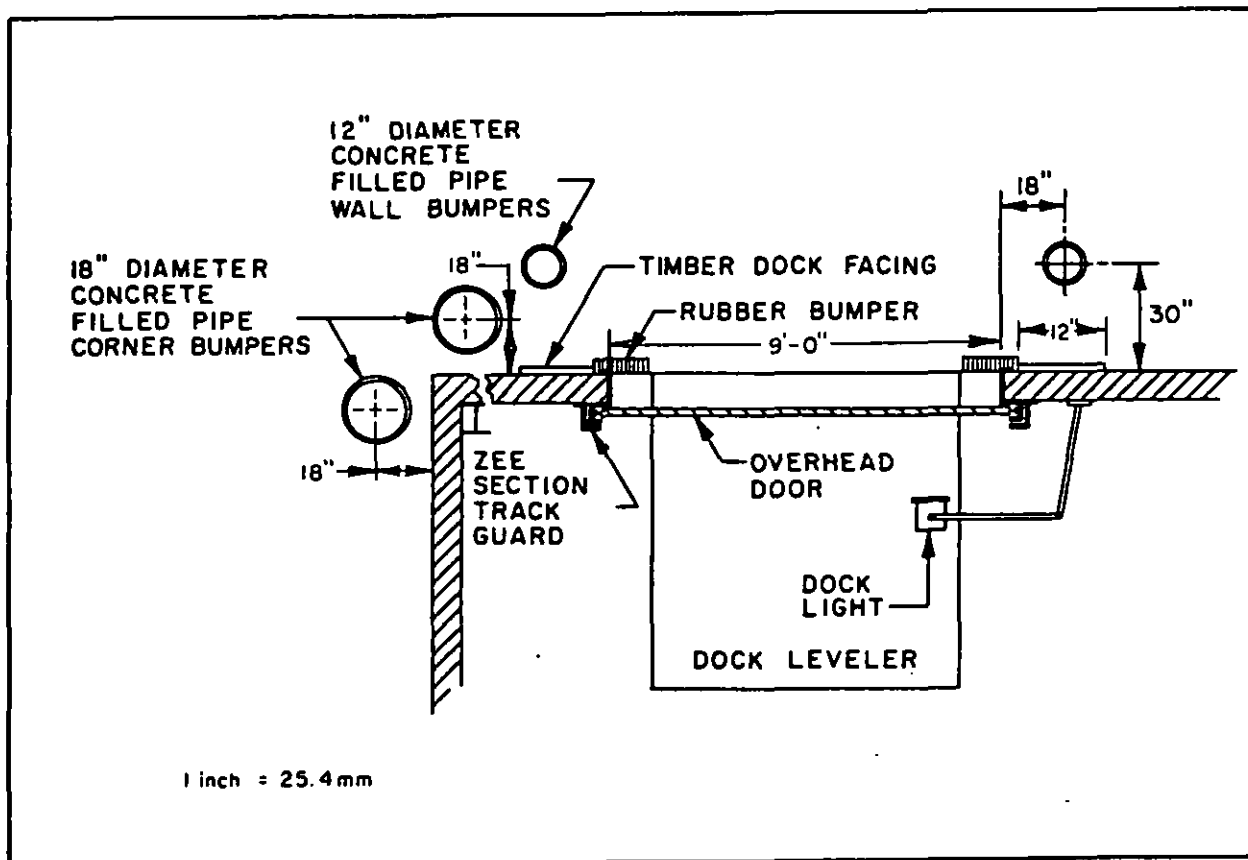

Figure 7  
Building Protection Devices

Table 3  
Truck and Rail Vehicle and Dock Heights

| TYPE OF TRUCK        | BED HEIGHT |      |         |      | OVERALL HEIGHT      |                     | DOCK HEIGHT |      | DOCK LEVELER LENGTH (Minimum) |         |
|----------------------|------------|------|---------|------|---------------------|---------------------|-------------|------|-------------------------------|---------|
|                      | Minimum    |      | Maximum |      | Minimum             | Maximum             | in.         | mm   | ft.                           | m       |
|                      | in.        | mm   | in.     | mm   |                     |                     |             |      |                               |         |
| Container            | 56         | 1420 | 62      | 1570 | 12'-2"<br>(3710 mm) | 13'-6"<br>(4110 mm) | 52          | 1320 | 6-10                          | 1.8-3.0 |
| Reefer               | 50         | 1270 | 60      | 1520 | 12'-6"<br>(3810 mm) | 13'-6"<br>(4110 mm) | 52          | 1320 | 6-8                           | 1.8-2.4 |
| Flatbed (1)          | 48         | 1220 | 60      | 1520 | ---                 | ---                 | 48          | 1220 | 6-12                          | 1.8-3.7 |
| Double Axle Semi (2) | 46         | 1170 | 56      | 1420 | 12'-0"<br>(3660 mm) | 13'-6"<br>(4110 mm) | 48          | 1220 | 6-8                           | 1.8-2.4 |
| Straight Semi (2)    | 44         | 1120 | 52      | 1320 | 12'-0"<br>(3660 mm) | 13'-6"<br>(4110 mm) | 48          | 1220 | 8                             | 2.4     |
| City Delivery        | 42         | 1070 | 48      | 1220 | 11'-0"<br>(3350 mm) | 12'-6"<br>(3810 mm) | 48          | 1220 | 6-8                           | 1.8-2.4 |
| Stake Body           | 42         | 1070 | 48      | 1220 | ---                 | ---                 | 48          | 1220 | 6-8                           | 1.8-2.4 |
| High Cube Van        | 32         | 810  | 38      | 960  | 13'-0"<br>(3960 mm) | 13'-6"<br>(4110 mm) | 43          | 1090 | 8-12                          | 2.4-3.7 |
| Furniture Van (3)    | 24         | 610  | 36      | 910  | 13'-0"<br>(3960 mm) | 13'-6"<br>(4110 mm) | 30          | 760  | 8                             | 2.4     |
| Step Van (3)         | 20         | 510  | 30      | 760  | 8'-6"<br>(2590 mm)  | 10'-0"<br>(3050 mm) | 30          | 760  | 6-10                          | 1.8-3.0 |
| Panel Truck (3)      | 20         | 510  | 24      | 610  | 8'-0"<br>(2440 mm)  | 9'-0"<br>(2740 mm)  | 30          | 760  | 8-10                          | 2.4-3.0 |
| Low Boy (3)          | 20         | 510  | 24      | 610  | ---                 | ---                 | 30          | 760  | 8-10                          | 2.4-3.0 |
| Box Car (4)          | 41         | 1040 | 44      | 1120 | ---                 | ---                 | 44          | 1120 | 6                             | 1.8     |
| Reefer Rail Car (4)  | 46         | 1170 | 52      | 1320 | ---                 | ---                 | 48          | 1220 | 5-6                           | 1.5-1.8 |

## Notes:

- (1) Dock height range of 48"-52" (1220-1320 mm)
- (2) Dock height of 50" (1270 mm) if serving semis only
- (3) Dock height of 48"-50" (1220-1270 mm) recommended with exterior ramp to elevate truck to provide nominal 30" (760 mm) dock height
- (4) Minimum dock leveler length determined by required clearance between rail car and dock

MIL-HDBK-1032/2

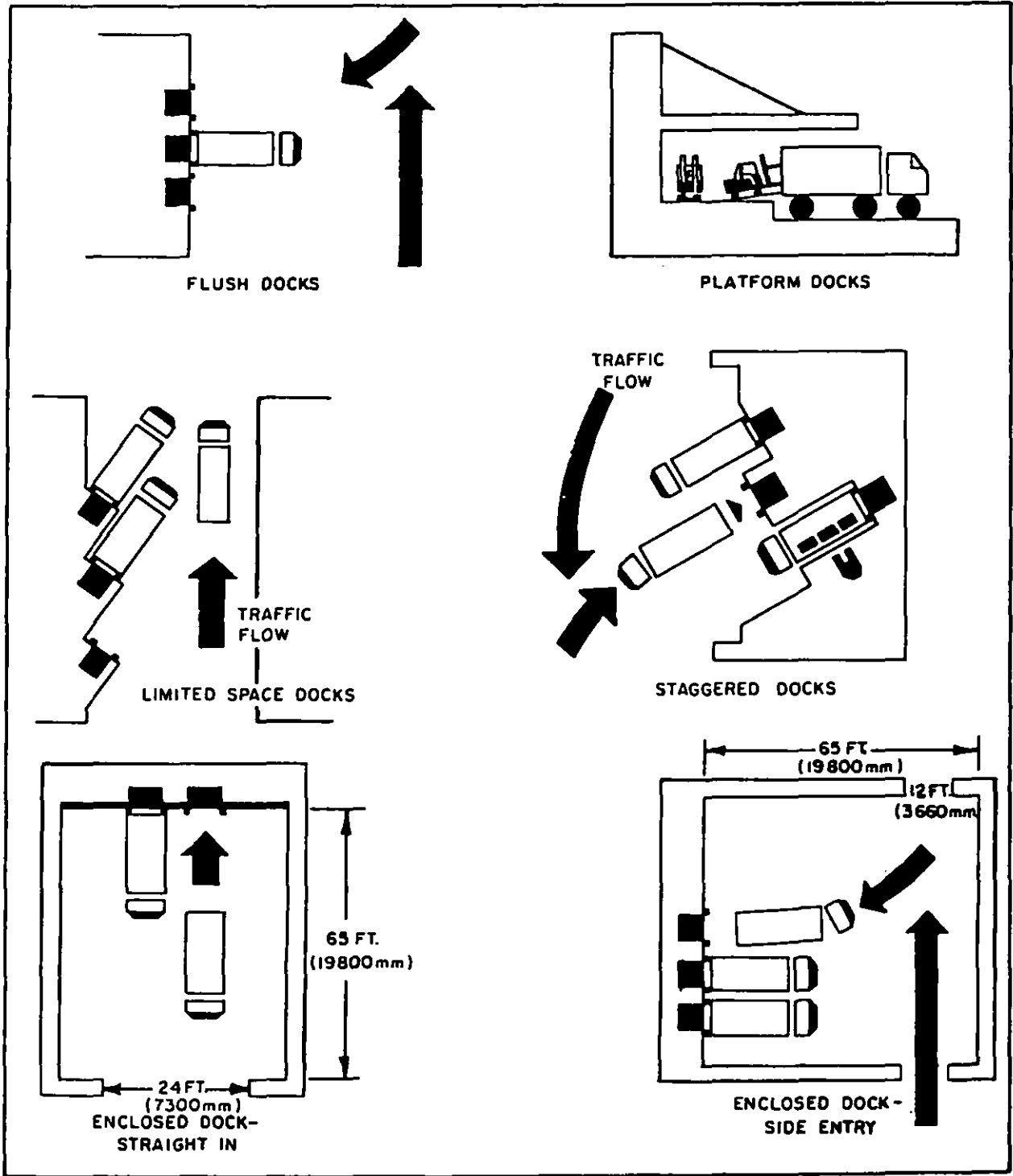

Figure 8  
Truck Dock Configurations

MIL-HDBK-1032/2

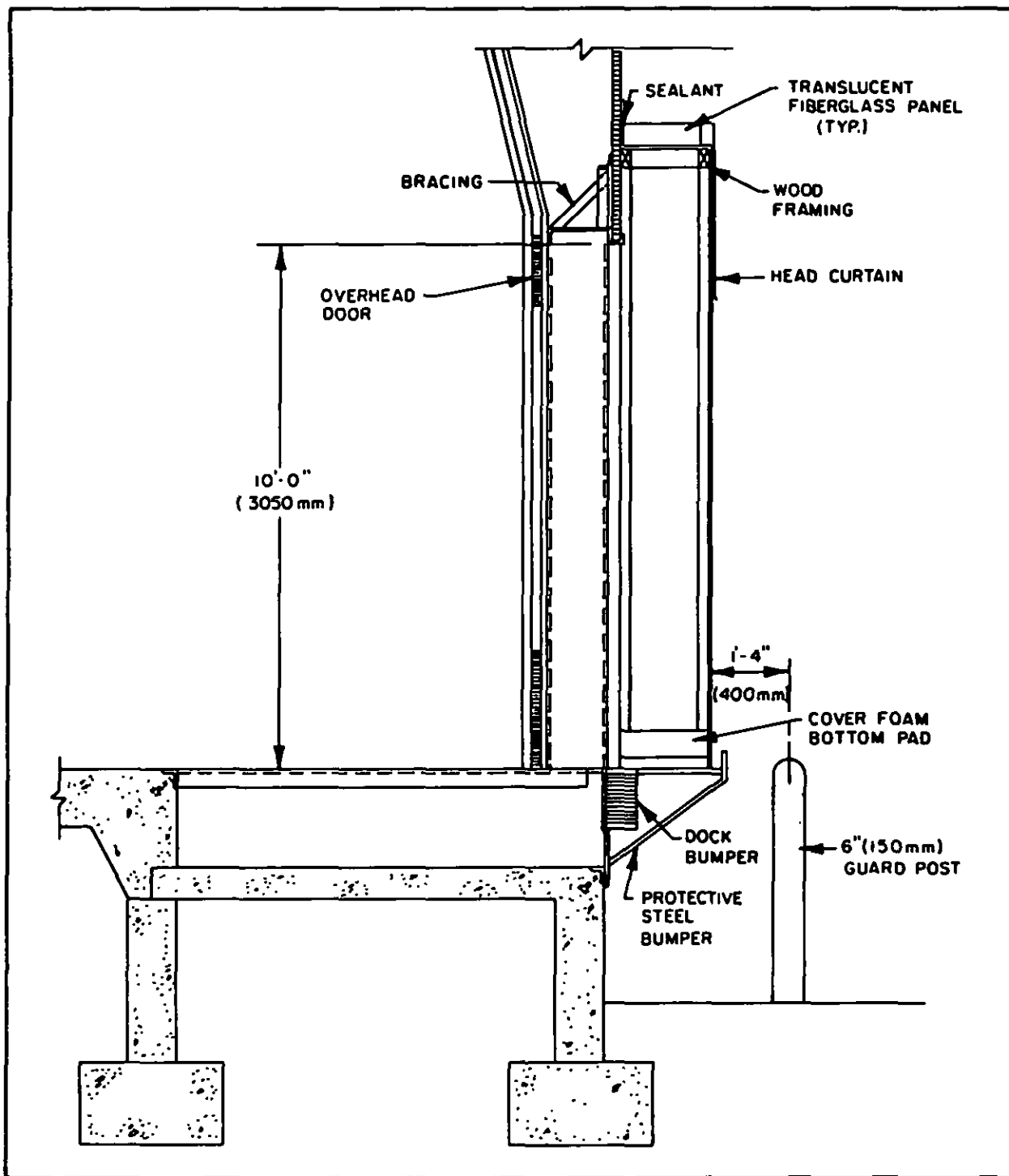

Figure 9  
Typical Truck Dock (Section)

MIL-HDBK-1032/2

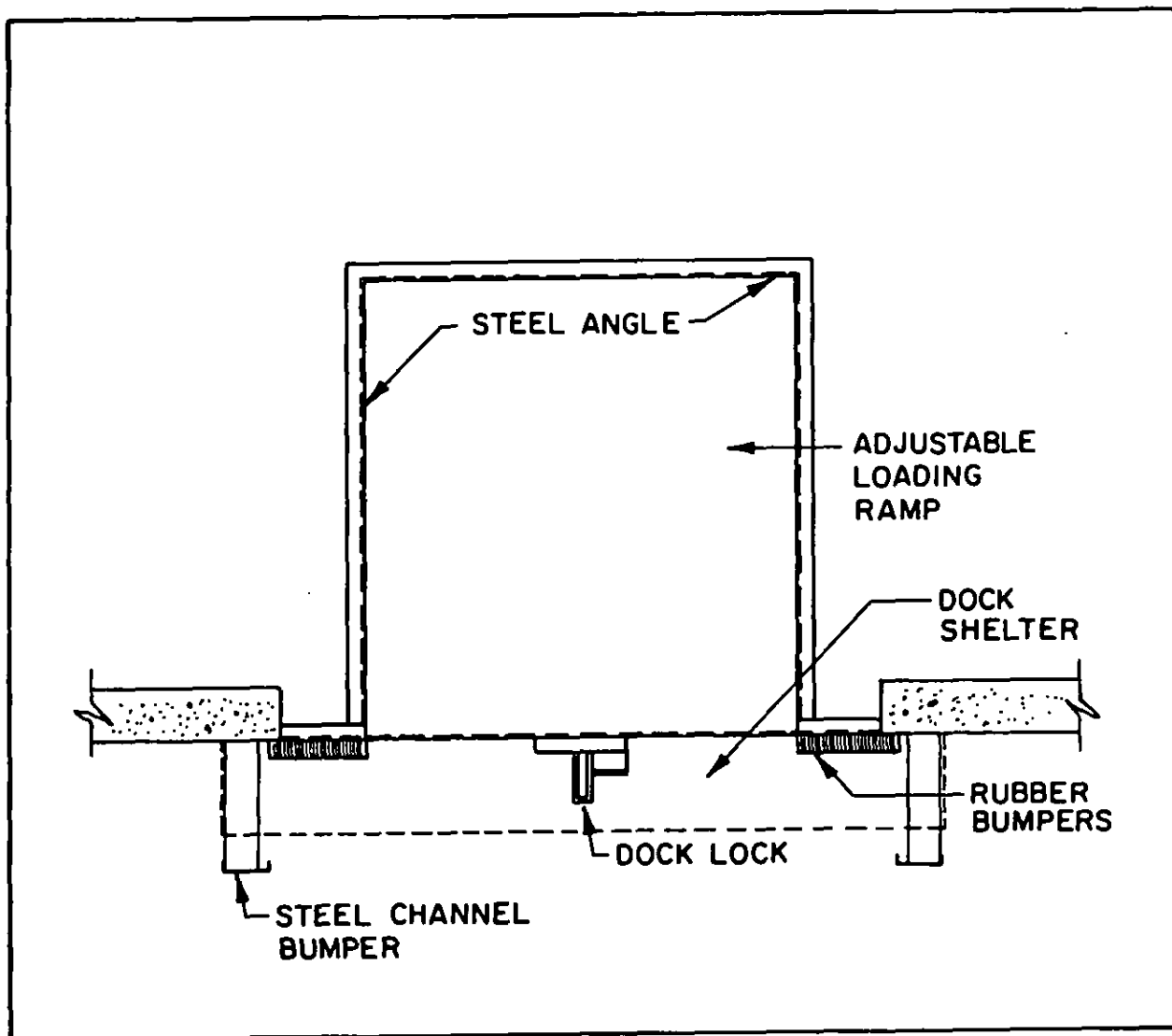

Figure 10  
Typical Truck Dock (Plan)

MIL-HDBK-1032/2

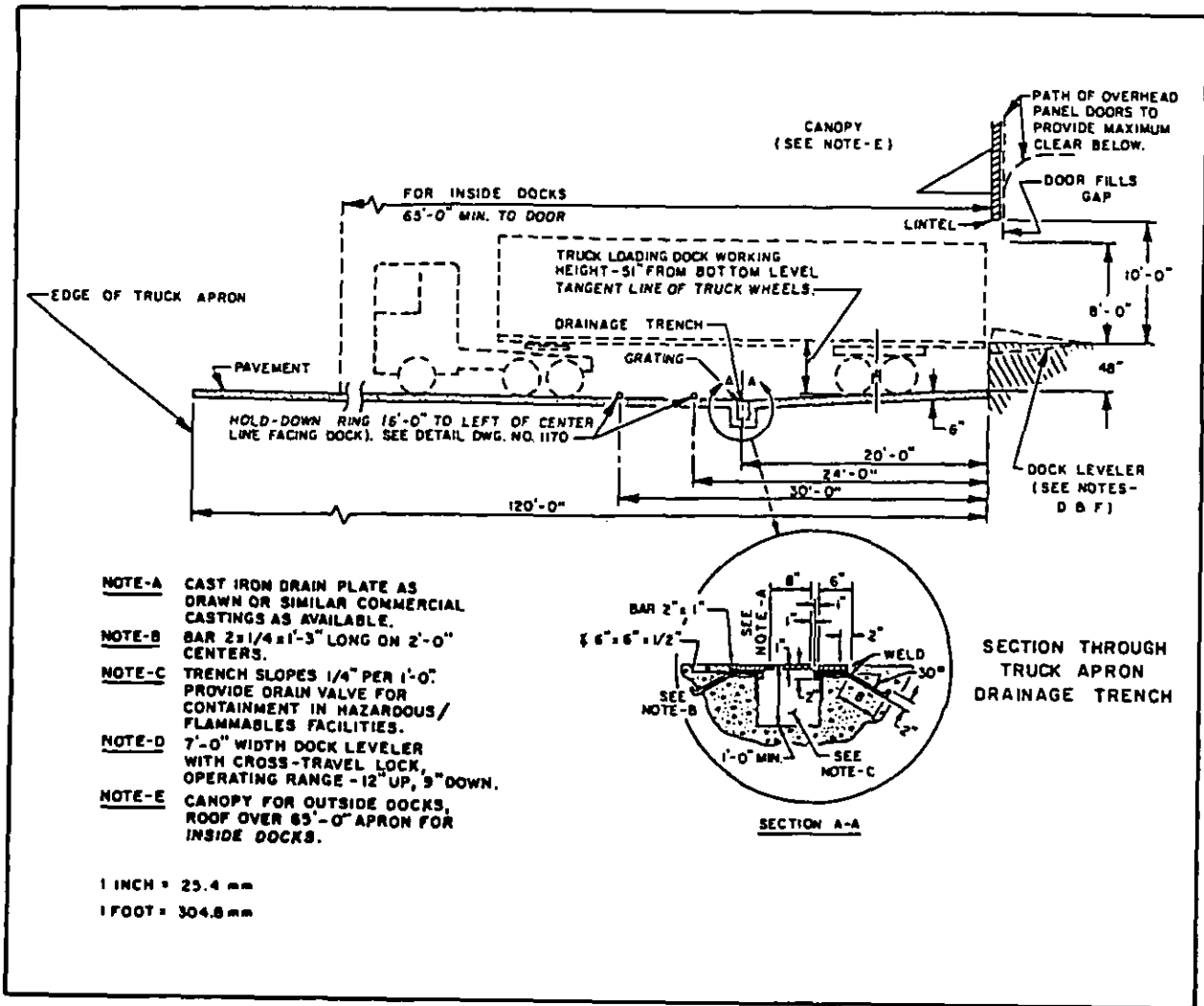

Figure 11  
Truck Apron Section

MIL-HDBK-1032/2

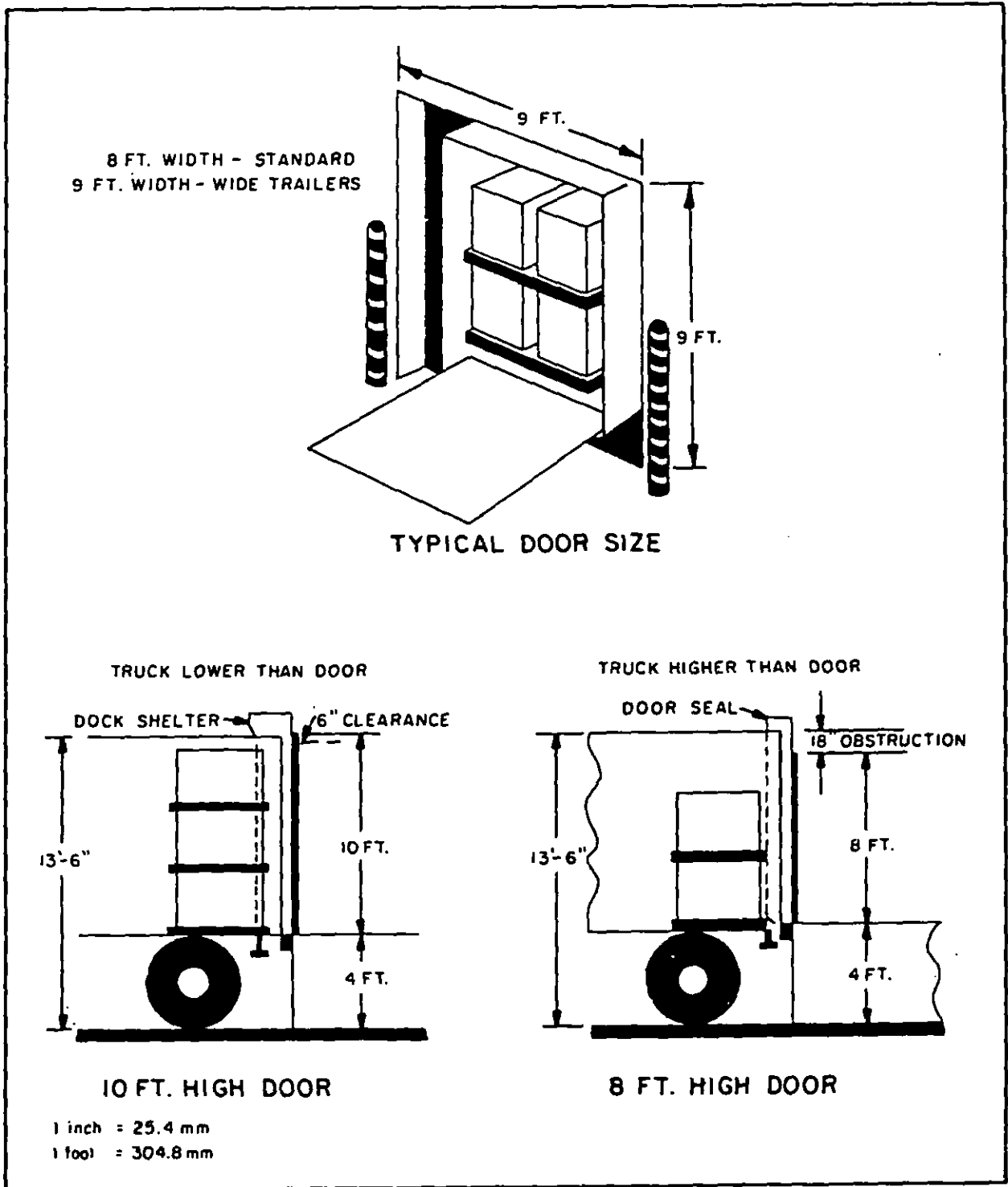

Figure 12  
Door Size Characteristics



## MIL-HDBK-1032/2

3.4.2 Rail Docks. Include provisions for rail docks (see Figure 13) as an option in the design of all storage facilities exceeding 40,000 square feet (3716 sq. m). There are three primary types of rail dock:

3.4.2.1 Outside Docks. Outside rail docks use through-the-wall access to rail cars without using an outside platform. Use inflatable seals to seal the space between the rail car and the warehouse. Include a wall-mounted dock board to provide access to the rail car.

3.4.2.2 Inside Docks. Inside rail docks may place the tracks inside the building in a pit constructed to place the car floor at the same level as the warehouse floor or on a floor level track. Pit type installations shall include track-mounted dock boards. Because of the large amount of warehouse storage space occupied by this type of dock, inside docks are not recommended except under extreme circumstances in which sheltering of the car or additional security is required.

3.4.2.3 Platforms. Platforms for rail service shall extend the full length of the building and be 15 feet (4570 mm) wide. Platform height above rails shall be 3 feet 8 inches (1118 mm) for general use. Equip platforms with track-mounted dock boards.

3.4.3 Ramp Access. Provide ramps at the end of rail platforms and at one warehouse truck dock door for vehicle access. Ramp slope shall not exceed 10 percent. Ramps for handicapped access shall be designed in accordance with the Specification for Making Buildings and Facilities Accessible to, and Usable by, the Physically Handicapped, American National Standards Institute (ANSI), A117.1-1961(R1980). Handicapped access ramp slope shall not exceed 8.33 percent.

3.4.4 Dock Levelers. Provide dock levelers at all truck and rail dock positions. Dock leveler life is directly affected by load weight, fork truck weight, and frequency of use. Specify dock leveler capacity to provide a minimum 20 year life (See Table 4).

3.4.5 Dock Weather Protection. Provide dock shelters or door seals in heated, refrigerated, and dehumidified warehouses, to seal the space between the truck or railcar and the building (see Figure 14). A canopy shall be used to shield docks from precipitation.

3.4.5.1 Dock Shelters. Use dock shelters in applications where truck size cannot be controlled. Sealing action is achieved through the wiping action of the shelter on the trailer when a truck backs into and through the shelter to the dock. Use shelters when the dock wall is not capable of resisting the compressive forces exerted by a door seal.

3.4.5.2 Door Seals. Door seals achieve a seal by compressing between the building wall and the trailer. Door seals provide greater sealing efficiency than dock shelters but require a structural wall capable of resisting compressive forces. Use of door seals requires close coordination of door opening size and trailer size. Excessive size incompatibility will require use of a dock shelter.

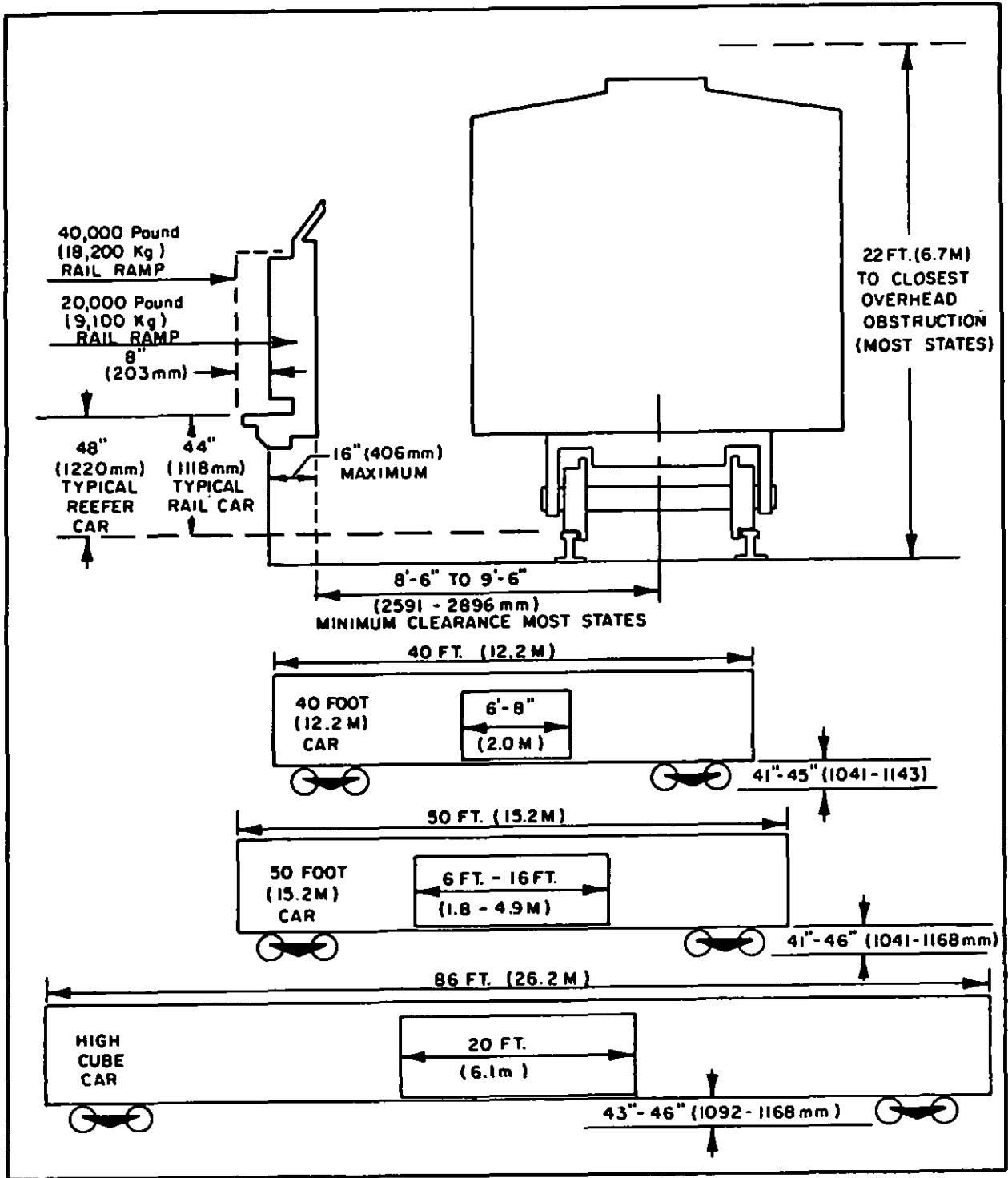

Figure 13  
Rail Car Characteristics

Table 4  
Dock Leveler Life (Years) Based on Impact Loading

| RATED CAPACITY            | WORKING SHIFTS | MAXIMUM GROSS LOAD<br>(Including weight of fork truck and load) |                          |                          |                          |                           |
|---------------------------|----------------|---|--------------------------|--------------------------|--------------------------|---------------------------|
|                           |                | 5,000 lb.<br>(2 270 kg)   | 10,000 lb.<br>(4 540 kg) | 15,000 lb.<br>(6 800 kg) | 20,000 lb.<br>(9 070 kg) | 25,000 lb.<br>(11 340 kg) |
| 20,000 lb.<br>(9 070 kg)  | 1              | +   | 13                       | -                        | -                        | -                         |
|                           | 2              | 19  | 7                        | -                        | -                        | -                         |
|                           | 3              | 9   | -                        | -                        | -                        | -                         |
| 30,000 lb.<br>(13,600 kg) | 1              | +   | +                        | 13                       | -                        | -                         |
|                           | 2              | +   | 13                       | 6                        | -                        | -                         |
|                           | 3              | 18  | 5                        | -                        | -                        | -                         |
| 40,000 lb.<br>(18 140 kg) | 1              | +   | +                        | 20                       | 8                        | -                         |
|                           | 2              | +   | +                        | 9                        | -                        | -                         |
|                           | 3              | +   | +                        | 5                        | -                        | -                         |
| 50,000 lb.<br>(22 680 kg) | 1              | +   | +                        | +                        | 16                       | 11                        |
|                           | 2              | +   | +                        | 15                       | 8                        | -                         |
|                           | 3              | +   | 18                       | 9                        | -                        | -                         |
| 60,000 lb.<br>(27 220 kg) | 1              | +   | +                        | +                        | 18                       | 12                        |
|                           | 2              | +   | +                        | +                        | 8                        | -                         |
|                           | 3              | +   | +                        | 15                       | -                        | -                         |

+ Estimated life in excess of 20 years

- Estimated life less than 5 years

MIL-HDBK-1032/2

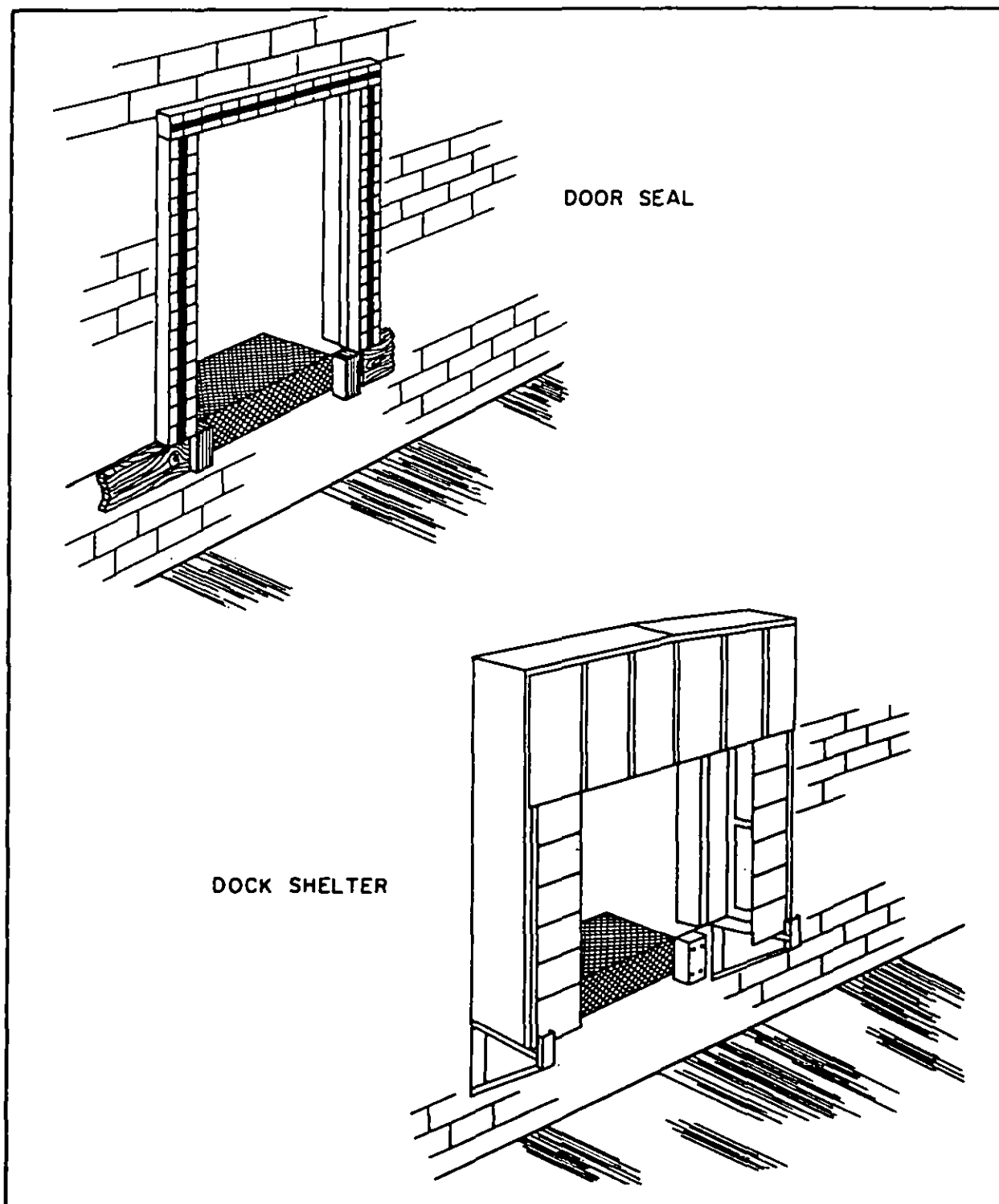

Figure 14  
Truck Dock Weather Seals

## MIL-HDBK-1032/2

3.4.5.3 Canopy. Provide a minimum 6 foot 0 inch (1830 mm) full length canopy (Figure 15) over outside docks to protect the trailer and door interface and dock shelter or door seal from excessive weather exposure.

3.4.6 Safety Equipment. Equip each truck dock with safety equipment consisting of wheel chocks and door-mounted lights to illuminate the trailer interior. In lieu of wheel chocks, dock levelers may be equipped with manually or electrically operated trailer restraints. Figure 16 illustrates a typical installation of a dock shelter, dock leveler, and trailer restraint device.

3.5 Construction. Economy and local availability of materials shall be a major factor in building design and selection of construction materials. The most prevalent construction materials are conventional structural steel frames with insulated metal siding or siding of protected metal or corrugated aluminum. Alternate systems may be used, including reinforced concrete frame construction with precast or masonry walls. Where possible, tubular interior columns shall be used in steel construction. Provide allowances for seismic and wind loads as required by Seismic Design for Buildings, NAVFAC P-355; and DOD 4270.1-M. Provide lightning protection per Lightning Protection Code, NFPA 78.

3.5.1 Construction Materials. Structural steel framing with insulated metal siding shall be used for economy and availability of components. Systems employing reinforced concrete frame construction or precast or masonry walls may be used, depending on their cost, availability of materials, and protective design and fire/hazardous chemicals protection requirements. Seismic and wind load factors shall be included in all designs. Roof systems may be of a tar, felt, and gravel buildup roof construction over a concrete deck or metal pan roof system, or a single layer membrane-type roof over insulation. Comply with requirements of DOD 4270.1-M and MIL-HDBK-1008 for combustibility and flame spread criteria.

3.5.2 Foundation. Foundation design shall be based on criteria in Foundations and Earth Structures, NAVFAC DM-7.02.

3.5.3 Structural Frame. Selection of a structural frame system other than steel must show careful study of the advantages and disadvantages of alternative systems, as well as the reasons for using the system considered most suitable. Before selecting structural systems, determine if the building will be wall-bearing or framed construction. Refer to the NAVFAC Architecture Criteria Manuals and Structural Engineering - General Requirements, NAVFAC DM-2.01, for criteria.

3.5.3.1 Selection Factors. Investigate the following during selection of the structural system:

- a) Availability of materials.
- b) Speed of erection.
- c) Local labor and construction practices.
- d) Quality of local materials.

MIL-HDBK-1032/2

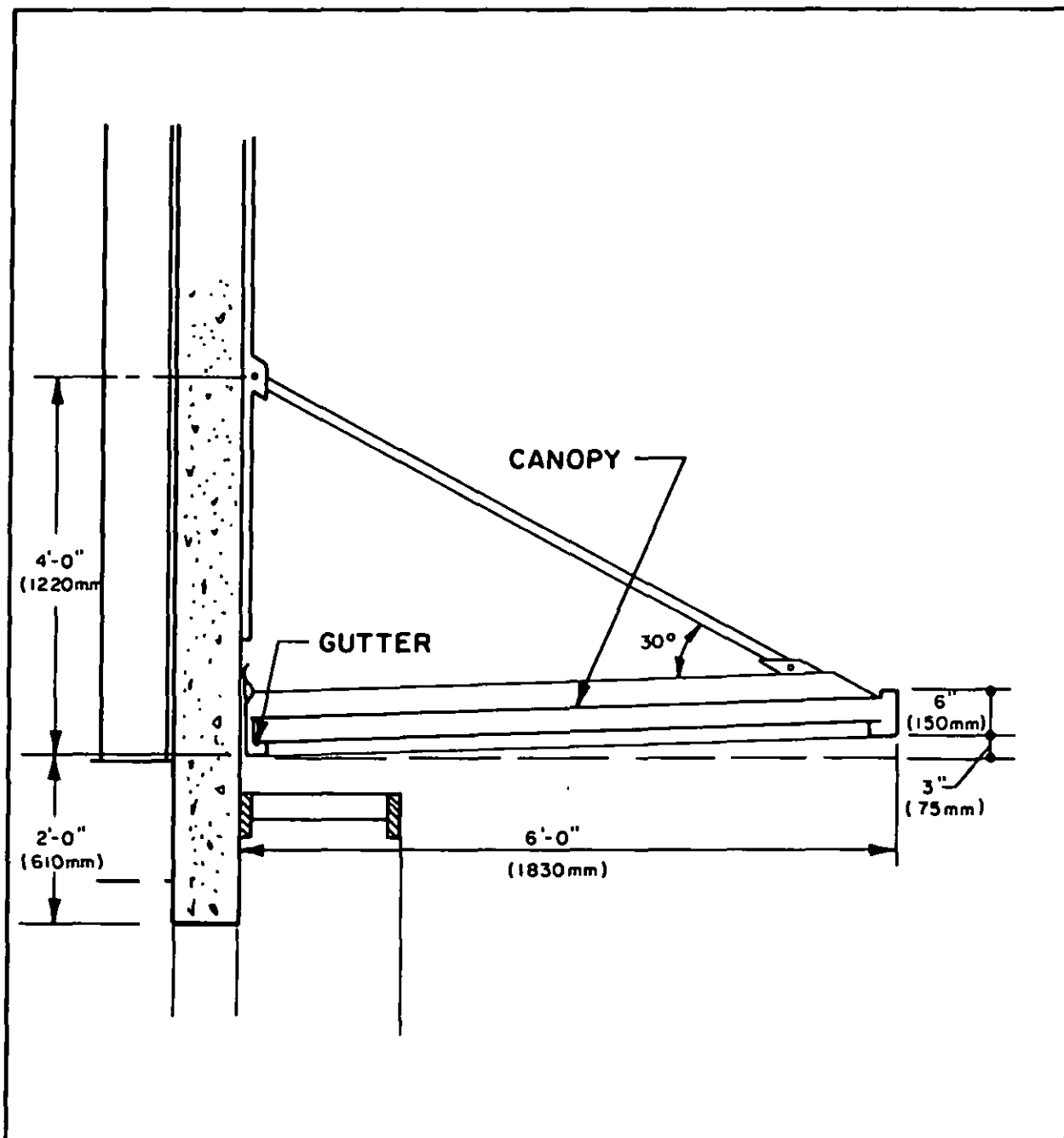

Figure 15  
Truck Dock Canopy

MIL-HDBK-1032/2

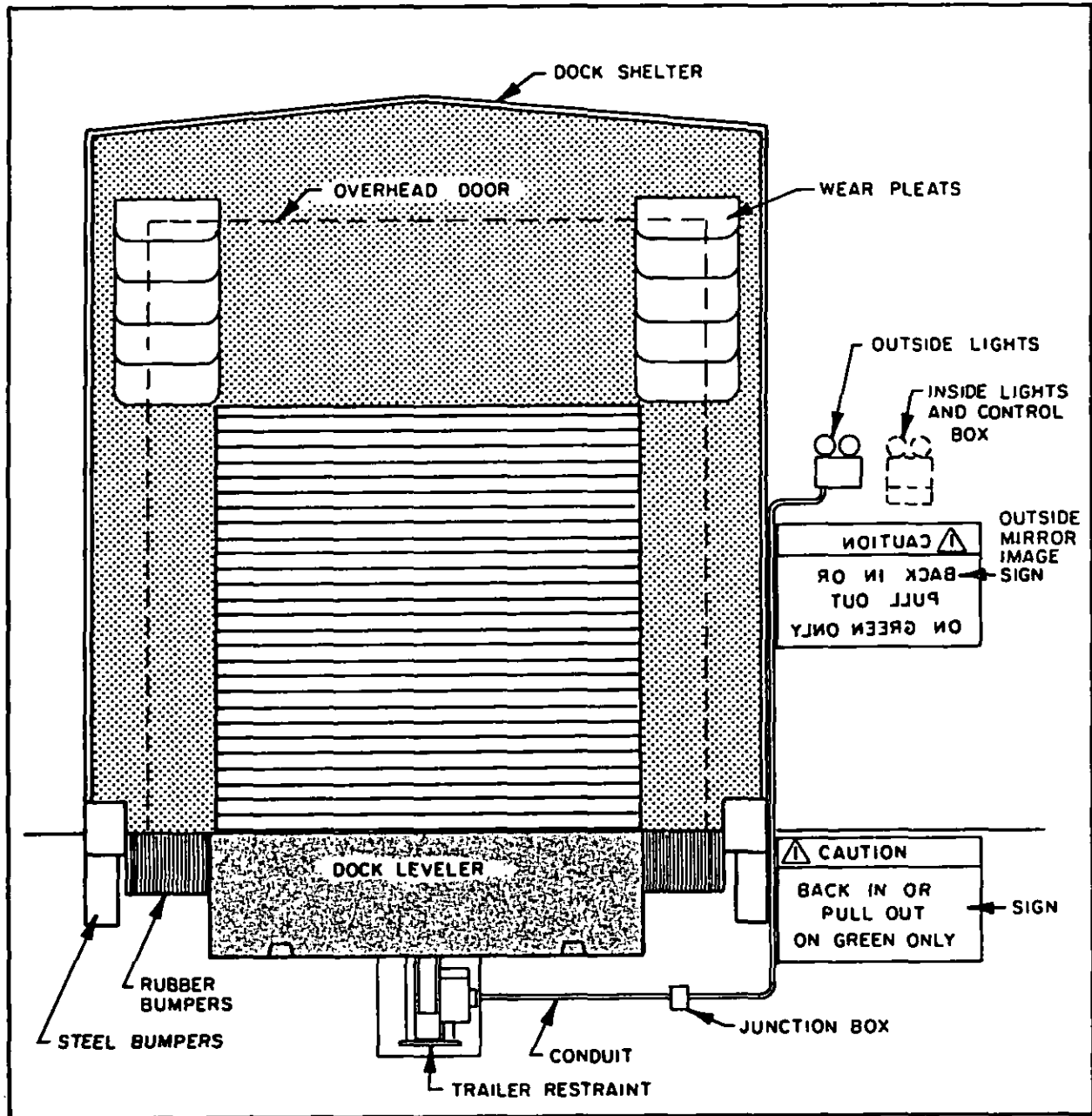

Figure 16  
Trailer Restraint System

## MIL-HDBK-1032/2

e) Limitations on materials by Department of Defense, Bureau of the Budget, or other mandatory standards.

f) Mandatory standard drawings and specifications for certain types of buildings, such as ammunition magazines.

g) Criteria for design of structures in typhoon, hurricane, and other high wind areas as described in NAVFAC DM-2.01.

3.5.3.2 Conventional Construction. Conventional column/beam/truss construction or pre-engineered designs may be used for buildings up to 44 feet (13 410 mm) in height.

3.5.3.3 Rack Supported Construction. Rack supported construction, in which the storage (pallet rack) system provides the building support in the storage area, shall be evaluated for all structures over 44 feet (13 410 mm) in height. For lower buildings, this method of construction shall be reviewed for economic suitability.

3.5.4 Roof. The following criteria apply:

a) Combustible roofing is permitted only in emergency construction.

b) Roofing construction may consist of steel decking, reinforced concrete, or precast concrete panels.

c) Gutters and downspouts shall be used. Positive measures must be taken to prevent accumulations of mud, snow, or ice.

d) Refer to Engineering and Design Criteria for Navy Facilities, NAVFAC P-34, for standards concerning materials and installation for built-up roofing. Insulate roofs in accordance with DOD 4270.1-M.

3.5.4.1 Flat Roofs. Flat roofs shall be used to minimize potentially unusable space caused by the roof rise associated with sloped roofs. Flat roofs shall have a minimum pitch of of 1/2 inch per foot (42 mm per meter).

3.5.4.2 Sloped Roofs. Sloped roofs having a pitch exceeding 1 inch per foot (83 mm per meter) shall be avoided for covered storage facilities unless available roofing materials require a greater pitch. Sloped roofs having a pitch of 3-4 inches per foot (250-333 mm per meter) may be used in small spans where roof rise can be limited to 5 feet (1525 mm) or less. Sheds may have a roof pitch of 2 inches per foot (166 mm per meter) or greater.

3.5.5 Exterior Walls. Exterior walls may be of insulated metal siding, brick or concrete masonry, or tiltup precast or cast-in-place concrete panels. When metal walls are used, the first 4 feet (1220 mm) of wall above the floor shall be of reinforced masonry construction to protect the structure from fork truck impact and provide additional security (see Figure 17). Walls located on sides designated for future expansion shall be removable.

3.5.6 Interior Walls. Interior wall construction will vary depending upon use, finish, and required fire and corrosion resistance. Refer to NAVFAC P-34 for specifications for the following:

a) Lath and Plaster



MIL-HDBK-1032/2

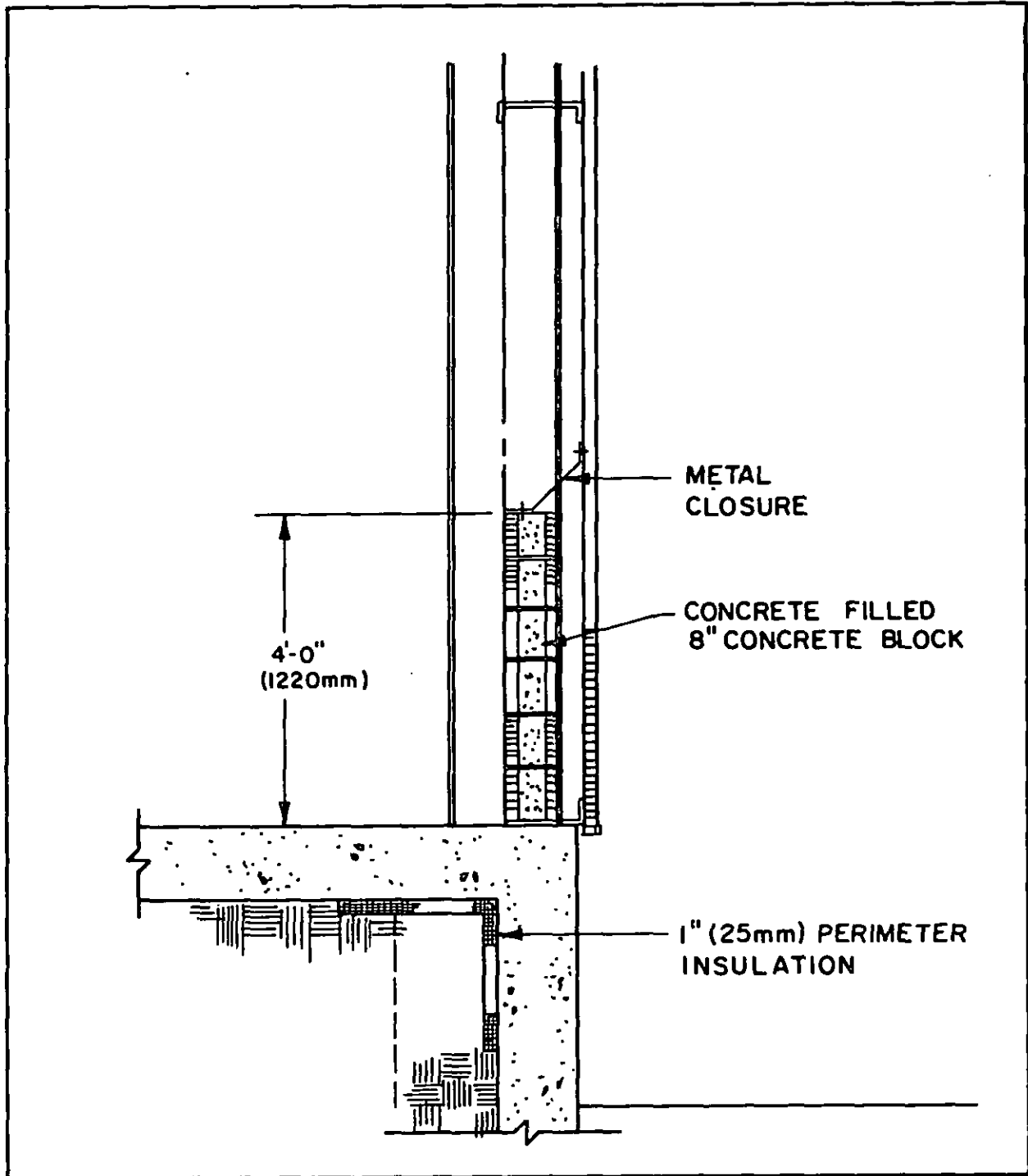

Figure 17  
Exterior Wall Detail

## MIL-HDBK-1032/2

- b) Dry Wall Construction
- c) Structural Facing Tile
- d) Concrete Masonry Units
- e) Toilet and Cubicle Partitions

3.5.6.1 Fixed Partitions. Refer to NAVFAC DM-1, Architectural Series, for construction and partition facing information for fixed partitions.

3.5.6.2 Movable Partitions. In selecting movable partitions, consider the fire rating, corrosives resistance, availability of modular size to meet the building module, ease of moving to a new location, acoustic properties, and cost. The use of low partitions in a landscaped interior shall be considered. Place all wiring in ceiling space or in-floor ducts. Wiring shall not be installed in movable partitions.

3.5.6.3 Wire Mesh Partitions. Consider these partitions for securing storage areas, tool cribs, issue rooms, and similar spaces.

3.5.7 Doors and Windows. Windows shall be provided for office and service structures. A continuous narrow band of high windows may be justified in large warehouses by savings in electric lighting costs. Skylights shall be considered to supplement inside lighting.

3.5.8 Interior Finishes. Interior finishes do not contribute structural gains to the construction and do not require secondary structural assemblies for installation. They do contribute surfaces exhibiting fire and corrosion protection, durability, appearance, or special maintenance qualities. Materials which contribute structural gain to the construction and have inherent surfaces or factory applied finishes that may be used as interior finishes are discussed in the NAVFAC Architecture Criteria Manuals.

Refer to NAVFAC P-34 for interior finish specifications, and the NAVFAC Architecture Criteria Manuals for material criteria. Refer to Color for Naval Shore Facilities, NAVFAC P-309, for color criteria.

3.5.9 Plumbing. Refer to NAVFAC DM-3.01 for the design of building plumbing systems including above ground and buried sanitary DWV (drain, waste, and vent), roof (storm) drainage, and water piping within and under each building and within 5 feet (1.5 m) outside of the building walls. In specific instances, connections to existing exterior distribution systems and buried piping beyond 5 feet (1.5 m) outside of the building walls may be included in the design.

3.5.10 Mechanical. Refer to Heating, Ventilating, Air Conditioning, and Dehumidifying Systems, NAVFAC DM-3.03, for criteria relating to the design, system and equipment selection criteria, control system criteria, and energy conservation considerations for heating, ventilating, air conditioning and dehumidifying systems.

## MIL-HDBK-1032/2

3.5.11 Electrical. Refer to Electrical Engineering, Design Considerations, NAVFAC DM-4.01, and Electrical Engineering, Electrical Utilization Systems, NAVFAC DM-4.04, for criteria relating to estimation of loads, selection of electric power source, and requirements for the installation, voltage level, grounding, and selection of electric distribution systems.

3.6 Floors. Critical attention to floor design and construction is essential to proper operation of narrow aisle high-rise storage systems. Refer to American Concrete Institute (ACI) Guide for Concrete Floor Slab Construction, ACI 302.1R-80, for design and construction of Class 5 floors.

3.6.1 Floor Construction. Where construction conditions permit, construct warehouse floors of reinforced concrete poured on-grade over a vapor barrier and 6 inch (150 mm) capillary barrier. Precision floor flatness requirements apply to storage areas only. Coordinate the location of floor joints, reinforcement steel, and in-floor utilities with vehicle guidance system and aisle requirements. If a specific layout is not known or is subject to change, floors shall be designed for any configuration of racks and shelving.

3.6.1.1 Concrete Strength. Concrete 28-day compressive strength shall be a minimum of 3,500 pounds per square inch (246 kg/square centimeter (cm<sup>2</sup>)).

3.6.1.2 Reinforcement. Provide crack control using reinforcement consisting of minimum number 6 welded wire fabric in a 6- by 6-inch (150 mm x 150 mm) mesh or alternative non-reinforced methods.

3.6.1.3 Flatness. Finished surfaces of nonstorage areas shall be checked for smoothness with a 10-foot (3050 mm) straightedge and comply with ACI Class Bx surface finish requirements. When placed at any location on the finished floor, in any direction, the plane of the floor surface shall not deviate from the plane of the straightedge by more than 5/16 inch (8 mm) at any location along the straightedge. There shall be no more than 5/16 inch (8 mm) deviation in any 10-foot (3050 mm) measurement. The elevation difference between any two points on the floor shall not exceed 1/2 inch (13 mm).

3.6.1.4 Thickness. Floor thickness will be determined by a combination of live load, dead load, strength of concrete, and subgrade conditions. The nomograph in Figure 18 is based upon information contained in Appendix D of NAVSUP PUB-529 and provides a means for determining floor load capacity or required floor thickness for varying conditions of concrete strength and subgrade reaction. Refer to Structural Engineering, Concrete Structures, NAVFAC DM-2.04; Soil Mechanics, NAVFAC DM-7.01; and NAVFAC DM-7.02, for more detailed information on floor and foundation design. Floors in covered storage facilities shall be no less than 6 inches (150 mm) thick.

3.6.1.5 Finishes. Floor hardeners, dressings, or toppings may be required for durability in areas of exceptionally high activity such as main aisles, towline paths, or industrial shop areas. Sealers are desirable for dust control.

43

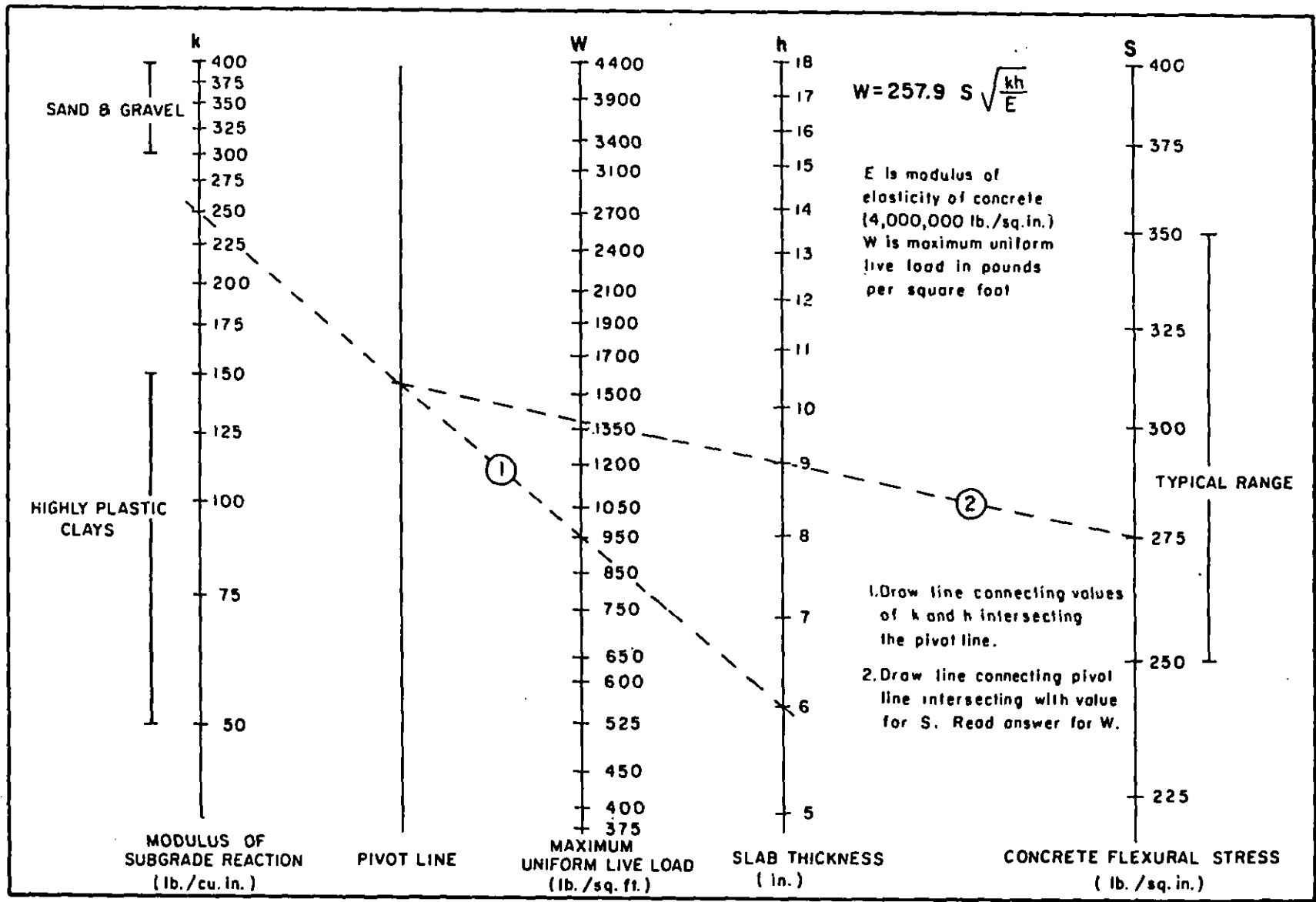

MIL-HDBK-1032/2

Figure 18  
 Floor Loading Nomograph

## MIL-HDBK-1032/2

3.6.1.6 Static Load. Floors shall be designed to support the estimated static load of stored material and storage equipment. Refer to Appendix D of NAVSUP PUB-529 for static floor load estimating criteria.

3.6.1.7 Impact Load. Floor design shall incorporate the effects of impact loads caused by operation of materials handling equipment. Consult equipment manufacturers for characteristics of specific vehicle impact loads.

3.6.2 Superflat Floors. High rise, narrow aisle storage systems with aisles less than 96 inches (2440 mm) wide and storage heights exceeding 20 feet (6100 mm) require extremely smooth and flat floors to control operating tolerances. Superflat floors shall be designed and specified for vehicles such as turret trucks and man-up order picking trucks.

3.6.2.1 Construction Guidelines. In order to assure that superflat tolerances can be achieved, the following design and construction guidelines shall be followed:

- a) Clearly identify on the design drawings those areas of the warehouse floor which must meet superflat tolerances.
- b) Incorporate a requirement in the construction contract for test slabs to assure that the superflat floor tolerances can be achieved with the contractor's proposed operations.
- c) All longitudinal construction joints shall be located outside of the aisles in which the trucks operate. Space transverse weakened plane joints to control random cracking and potential slab warping. A transverse joint spacing of 20 feet (6100 mm) will generally be satisfactory. Transverse joints shall be sawed and sealed.
- d) Locate floor drains, cleanouts, conduits, and other floor discontinuities outside of the aisles.
- e) Specify a concrete mix having a low water-cement ratio and low shrinkage characteristics. Achieve concrete workability through use of plasticizers in lieu of additional water.
- f) During construction, pour concrete between rigid forms in lanes less than 20 feet (6100 mm) wide. Strike off concrete with a vibrating screed.
- g) After initial floating, use a 10 foot (3050 mm) long transverse scraping straightedge (highway straightedge) to remove high spots.
- h) Check the surface of the plastic concrete frequently with a 10 foot (3050 mm) long straightedge placed both parallel and transverse to the centerline. Correct any high spots and fill any low spots using the highway straightedge.

3.6.2.2 Measurement. New criteria for tolerances and measurement of superflat floors are currently under development. The following requirements are provided as interim guidance:

- a) In specifying floor flatness for turret truck and order-picking truck operations, require a complete (100%) profile analysis of the wheel path portion of the concrete floor in the storage aisles and a statistical profile analysis of other portions of the concrete floor on which turret trucks and order-picking trucks will operate.

## MIL-HDBK-1032/2

b) For measurement of floor flatness, require use of special floor flatness profile measurement equipment such as the "Profilograph" of the Edward W. Face Company (427 West 35th Street, Norfolk, Virginia 23508), the "Floor Crab" of the Austin Company-Kalman Floor Company (2942 Highway 74, Evergreen, Colorado 80439), or an equivalent measuring equipment technique which is certified as acceptable by the Headquarters Office of the truck manufacturer(s) and approved by the Contracting Officer.

c) Require in the specifications that the general contractor provide certification to be prepared by the measuring equipment operator. Certification states that the "wheel path" and other portions of the concrete floor to be used for turret truck and order-picking truck operations must completely meet maximum rated productivity floor flatness requirements of the Headquarters Office of the truck manufacturer(s). Floors which fail to meet the required tolerances will be corrected as directed by the Contracting Officer.

d) All noncritical floor slabs shall be specified to be an ACI Class Bx floor. See ACI 302.1R-80 for Class Bx criteria.

3.6.3 Wire Guide Requirements. When electronic wire guide vehicle controls are used, observe the following floor design criteria:

3.6.3.1 Conduits. Avoid installing conduits in the floor.

3.6.3.2 Reinforcing. Reinforcing steel shall be located at least 2 inches (50 mm) below the concrete surface. Wire mesh shall be tack-welded together wherever possible. Rebars and wire mesh shall be grounded.

3.6.3.3 Expansion Joints. Where possible, expansion joints shall be located under storage racks. When expansion joints are located in the storage aisle, they shall run parallel to the aisle and not be within 3 inches (75 mm) of the centerline of the storage aisle nor within materials handling equipment wheel tracks.

3.6.3.4 Hardening Agents. If a ferrous hardening agent is specified, this material must be distributed evenly over the entire floor.

3.7 Fire Protection. All storage structures shall be designed to comply with the applicable sections of the fire safety codes governing the activity. Rack storage system fire protection shall comply with the requirements of MIL-HDBK-1008 and the Standard for Rack Storage of Materials, NFPA 231C. Floor storage over 12 feet (3660 mm) high shall also comply with Standards for General Storage, NFPA 231.

3.7.1 Location of Buildings. Building location on the site shall permit easy access by emergency vehicles. Orderly flow of people and equipment is essential to the conduct of a safe operation.

3.7.2 Fire Apparatus Access. Provide space between buildings sufficient to permit access by fire and emergency vehicles.

## MIL-HDBK-1032/2

3.7.3 Separation Distance. As an aid to fire prevention and protection, covered storage facilities shall be separated by the distances described in paragraph 3.3. Multipurpose warehouses may be constructed as a single structure. These buildings may include a flammable/hazardous storage area contiguous to the general warehouse, provided the two storage areas are separated by a 4-hour fire wall.

3.7.4 Protected Area. Warehouse fire area between fire walls shall comply with MIL-HDBK-1008 and be subject to the following:

3.7.4.1 General Storage. Warehouse area for storage of materials of moderate combustibility shall not exceed 40,000 square feet (3716 square meters [m<sup>2</sup>]) between fire walls in accordance with DOD 4270.1-M and shall otherwise conform to NFPA 231. When such warehouses are located at depot-type activities that furnish supply support to other activities, the area confined by fire walls may be increased upon a finding and determination by the Secretary of the Navy (with documentation submitted via cognizant claimant and NAVFAC fire protection engineers) that:

- a) The increased size is required for efficient operation.
- b) Additional loss potential has been recognized and is acceptable.
- c) Other fire safety features have been designed to compensate for the additional hazard as far as such design is practical.

3.7.4.2 Flammable/Hazardous Storage. Warehouse areas for storage of flammable liquids, solids, and/or hazardous chemicals, shall not exceed 20,000 square feet (1858 m<sup>2</sup>) between fire walls in accordance with DOD 4270.1-M. Fire walls shall have a 4-hour rating.

3.7.5 Sprinkler Systems. Provide automatic fire suppression systems in accordance with provisions of MIL-HDBK-1008; Carbon Dioxide Extinguishing Systems, NFPA 12; Halon 1301 Fire Extinguishing Systems, NFPA 12A; Standard for the Installation of Sprinkler Systems, NFPA 13; Deluge Foam-Water Sprinkler Systems and Foam-Water Spray Systems, NFPA 16; NFPA 231; and NFPA 231C. Water demand shall be based on the hydraulic design of the sprinkler system.

3.7.5.1 Storage System Sprinklers. In general purpose, controlled humidity, refrigerated and other type warehouses where flammable/hazardous materials are not to be stored, nonadjustable face and flue sprinkler heads (see Figure 19) are required at or immediately below the 20-, 40-, 60- and 80-foot (6100 mm; 12 190 mm; 18 290 mm; and 24 380 mm) rack levels. Rack shelving at these levels shall not be adjustable. Additional flue sprinklers may be required depending upon storage height and its relationship to the nonadjustable sprinklers. Face and flue sprinkler heads shall be placed at or below each 108-inch (2745 mm) open frame shelf at the required levels in a manner which prevents sprinkler head damage during storage operations, as illustrated in Figure 20. The sprinklers at all other shelf levels shall be capable of vertical adjustment (Figure 21) using mechanically grooved fittings. Depending upon Commodity Class and whether the load is encapsulated, rack systems with clear stacking height (SH) values of less than 25 feet (7620 mm) from floor to the top of material on the top shelf may be exempted from the in-rack sprinkler requirement.

MIL-HDBK-1032/2

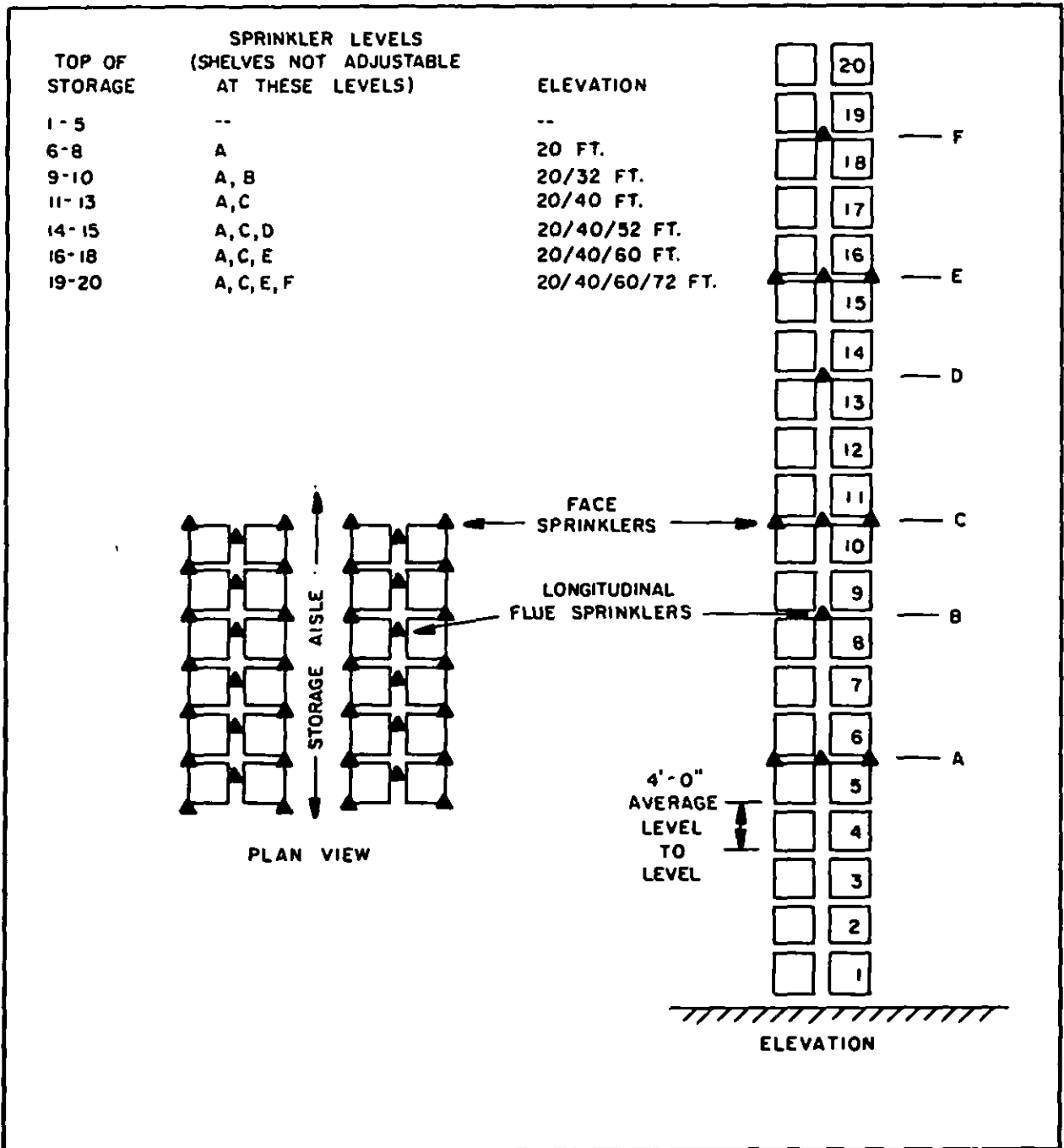

Figure 19

Standard Navy In-Rack Sprinkler Arrangement

(Class I, II, III, IV Commodity Storage Height Over 25 Feet - Excludes Flam/Haz Storage Facilities)



MIL-HDBK-1032/2

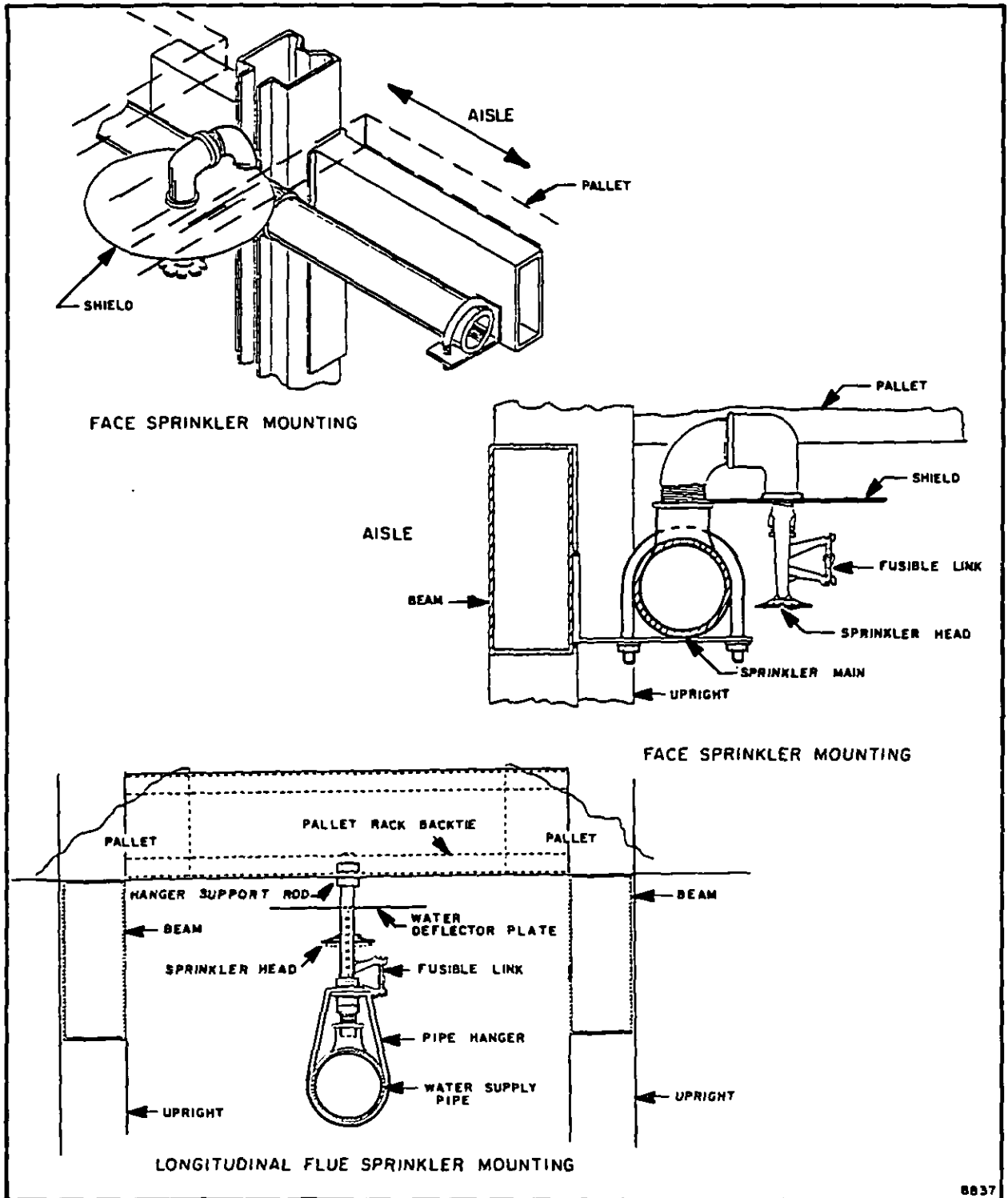

8837

Figure 20  
Standard Navy Face and Longitudinal Flue Sprinkler Mounting  
(to Prevent Pallet and Load Interference)

MIL-HDBK-1032/2

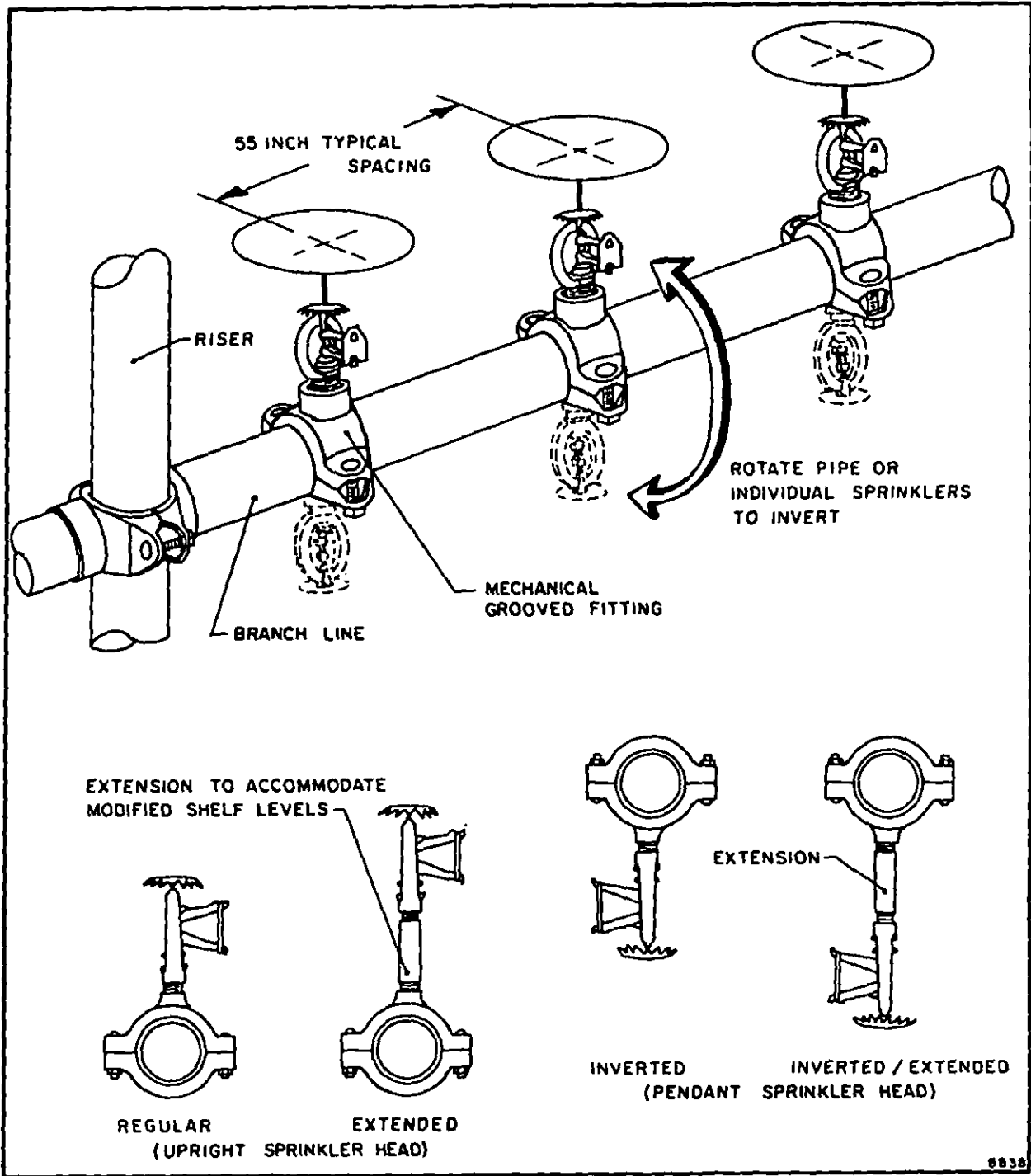

Figure 21  
Standard Navy Flam/Haz Flue Sprinkler System  
(to Permit Adjustment of Flam/Haz Rack Shelves -  
Face Sprinklers Not Required)

## MIL-HDBK-1032/2

In flammable/hazardous materials storage areas, flue sprinklers are required above each shelf level in accordance with NFPA 30. Racks in flammable/hazardous areas are limited to SH values of 25 feet (7620 mm) from the floor to the top of material on the top shelf level. Sprinkler heads must be positioned so they do not interfere with pallet loads that overhang shelf beams as much as 3 inches (75 mm) into the flue.

3.7.5.2. Water Supply. Evaluation of the available water supply shall be a primary consideration in the preliminary design stages of any covered storage facility. Water supply duration shall be at least two hours for all classifications of commodities. If the volume and pressure available in water mains is inadequate, onsite storage in the form of a water tower or ground storage tank with fire pumps may be required to provide an adequate supply of fire fighting water.

3.7.6 Hose Connections. Hose connections shall be provided with 75 foot (22.9 m) long hoses at suitable locations to achieve overlapping coverage of all areas of the warehouse.

3.7.7 Fire Walls. Fire walls shall be of brick or concrete masonry construction, have sufficient thickness to develop a 4-hour fire resistance, have independent structural stability, and be continuous to the roof. Fire wall projection above the roof shall be subject to the following:

a) Where roof decks are made of heavy noncombustible materials such as concrete or gypsum, parapets are not required provided the fire walls fit tightly against the inside of the roof deck.

b) Where roof decks are Factory Mutual approved Class I steel decks, a 12-inch (300 mm) parapet is required.

c) All other roof decks require a 30-inch (760 mm) parapet measured from the top surface of the lower roof to the top of the parapet.

3.7.8 Fire Doors. In heater rooms and transformer vaults, doors shall be metal-covered or industrial-type metal doors or fire doors, as required. Metal overhead doors shall be chain hoist operated, except when frequent use demands motorized operation. Openings in 4-hour rated interior fire walls shall be protected by a fire-rated door on each side of the wall. Refer to DOD MIL-HDBK-1008 and DOD 4270.1-M.

3.7.9 Ventilation. Provide lock-in type roof vents to achieve a venting ratio based upon the heat release of the contents and in accordance with the Guide for Smoke and Heat Venting, NFPA 204M. Recommended venting ratios of vent area to floor area are 1:150 for low heat release, 1:100 for moderate heat release, and 1:50 for high heat release. Use of roof vents as skylights to reduce electrical lighting requirements shall be considered. Include draft curtains in storage facilities in accordance with NFPA 204M. Draft curtains shall define areas of 20,000 square feet (1858 m<sup>2</sup>) or less and be positioned so as not to interfere with storage operations.

3.8 Architectural Details. Observe the following architectural details during facility design:

## MIL-HDBK-1032/2

3.8.1 Battery Charging and Handling Operations. Provide an equipped and ventilated area for the charging of materials handling vehicle batteries. Figures 22 and 23 illustrate typical battery charging layouts. Refer to General Maintenance Facilities, NAVFAC DM-28.04, for additional information regarding enclosed battery charging areas.

3.8.1.1 Safety Showers/Spill Control. Provide facilities for emergency drenching of the eyes and body, flushing and neutralizing spilled electrolyte, fire protection, and protecting charging apparatus from damage by vehicles (Figure 24), in accordance with American National Standard for Emergency Eyewash and Shower Equipment, ANSI Z358.1-1981. Battery charging areas shall be equipped with neutralizing chemicals. Floors shall be treated with an acid resistant coating. Install permanent eye wash and shower facilities wherever permanent charging or servicing areas are constructed.

3.8.1.2 Fire Extinguishing Equipment. Fire fighting equipment, consisting of fire extinguishers of either the carbon dioxide or dry powder type suitable for use on chemical and electrical fires, shall be included in the battery charging area.

3.8.1.3 Battery Handling Equipment. Provide specialized battery handling equipment in battery charging and work areas. Equipment used must be selected based on the characteristics of the vehicle and battery being serviced, the activity of the charging station, and the maintenance work performed on the battery. Devices include handling beams, jib hoists, special charging stations, and battery transporters.

3.8.1.4 Ventilation. Provide natural and mechanical exhaust ventilation to ensure diffusion of the gases from the battery and to prevent the accumulation of an explosive mixture. Provide ventilation to limit hydrogen gas buildup to no more than 1 percent by volume in room air. If battery charging room air is air conditioned as part of a general building air conditioning system, exhaust air directly to the outdoors and do not return it to the air distribution system. Required air changes shall be based on the expected activity in the charging room, but shall be no less than six air changes per hour. Activity must consider the number of cells being charged at a given time and the charging current being used. Provide an air velocity rate across battery charging shelves of at least 125 feet per minute (0.64 m/s) in accordance with NAVFAC DM-28.04 and the American Conference of Governmental Industrial Hygienists Industrial Ventilation Manual. Interlock the ventilation system with the chargers to prevent charger operation unless the ventilation system is operating. Refer to NAVSUP PUB-529, Section 23.4.4, for charging rate and hydrogen production criteria.

MIL-HDBK-1032/2

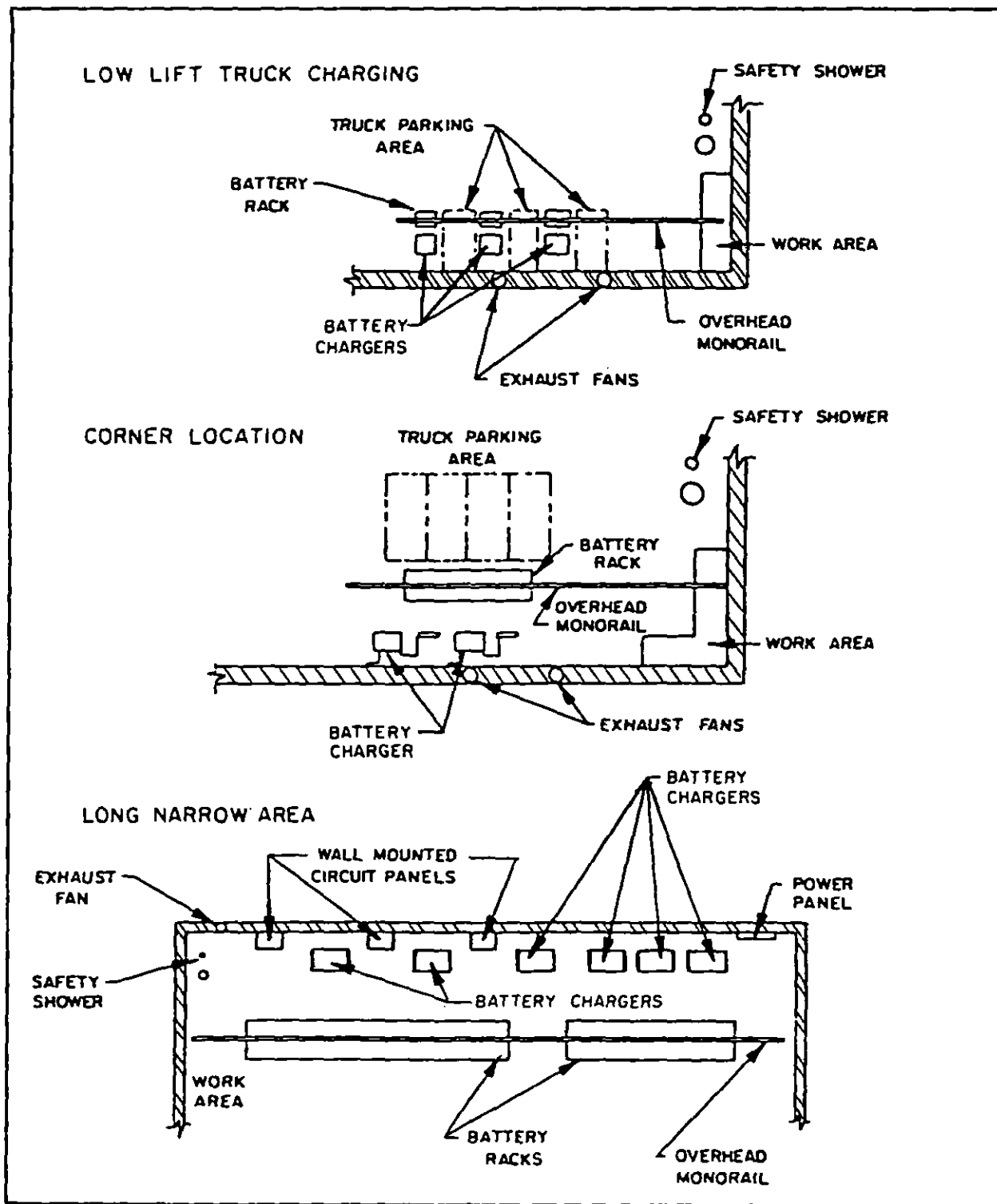

Figure 22  
Battery Charging Area (Open Locations)

MIL-HDBK-1032/2

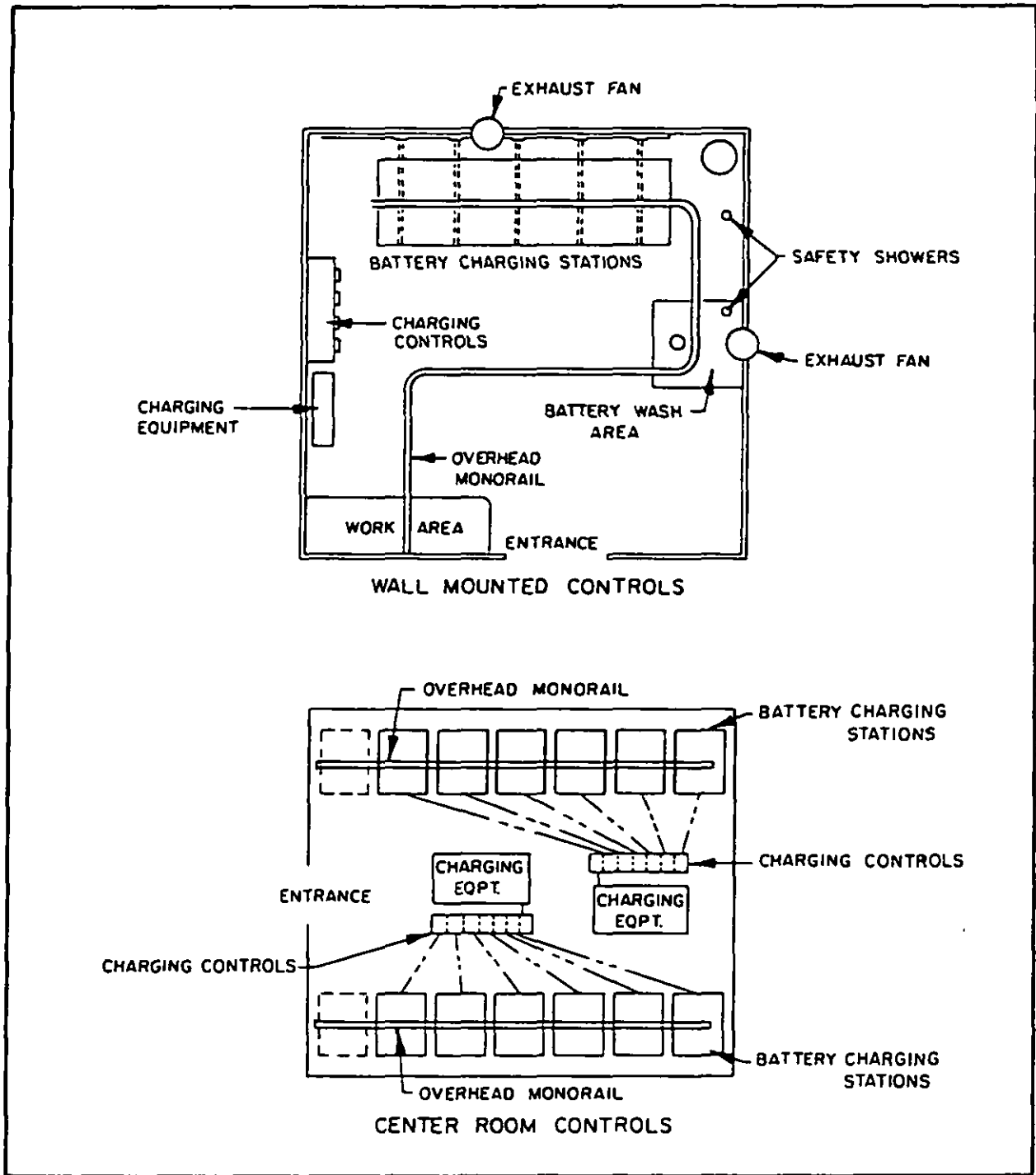
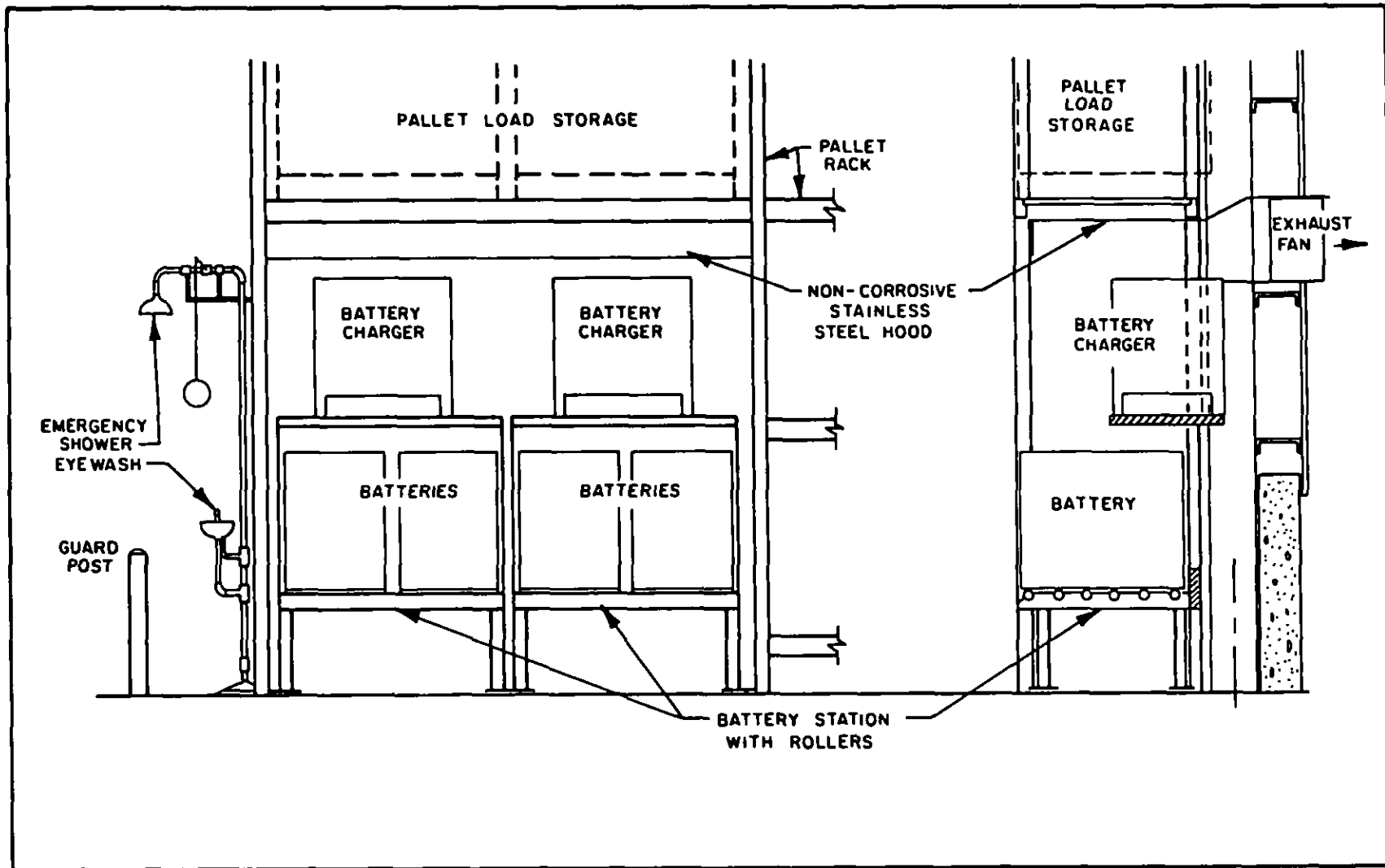

Figure 23  
Battery Charging Area (One-Entrance Room)



54

MIL-HDBK-1032/2

Figure 24  
Typical Battery Charger Installation  
(With Eye Wash/Shower)

## MIL-HDBK-1032/2

3.8.2 Pallet Racks. Selective pallet racks (see Figure 25) consist of uprights, pallet beams, bracing, and miscellaneous accessories. Minimum design load shall be 3,000 pounds (1360 kg) per pallet. Installation must observe the following:

3.8.2.1 Dimensions. Pallet racks shall have a 40-inch (1020 mm) depth and accommodate standard 40- x 48-inch (1020 mm x 1220 mm) Navy pallets without front or rear pallet overhang (see Figure 26). Use of other sizes of pallet racks or pallets must be documented and justified. Beam to beam vertical spacing averages 48 inches (1220 mm) (see Figure 27).

3.8.2.2 Stability. Rack stability is influenced by loading conditions, attachment, and rack assembly. Racks exceeding a 6:1 height to depth ratio must be securely anchored or braced externally. For standard Navy racks, this applies to racks exceeding 20 feet (6096 mm) in height.

3.8.2.3 Flue Space. Fire protection requirements dictate a minimum longitudinal flue space (Figure 28) of 6 inches (150 mm). Flues shall be 12 inches (300 mm) deep in refrigerated areas. In flammable/hazardous materials storage areas, provide 12-inch (300 mm) flues between back-to-back racks. Flues of 8-12 inches (200-300 mm) shall be provided between backs of racks and walls. Navy standard pallet racks provide a minimum 4-inch (100 mm) transverse flue space. Comply with NFPA 231C if rack or load sizes are changed.

3.8.2.4 Attachment. Securely attach all pallet racks to floors, walls, and each other, to ensure stability and safety. Cold storage facilities require special rack attachment procedures. Refer to subparagraph 6.5.4 for cold storage rack attachment criteria.

3.8.2.5 System Interface. Interface operations with pallet rack using pickup and delivery (P&D) stations, as illustrated in Figure 29. Provide additional cross-aisle width to accommodate these P&D stations.

3.8.3 Aisle Dimensions. Coordinate aisle dimensions with specific equipment requirements. Observe the following:

3.8.3.1 Rail Guidance. Coordinate rail locations with pallet rack and vehicle characteristics (see Figure 30). Provide sufficient cross aisle width to accommodate the entrance flare.

3.8.3.2 Wire Guidance. Coordinate guide wire locations with pallet rack and vehicle characteristics (see Figure 31). Review guide wire location plan to provide a continuous loop and avoid crossovers. Install loop driver and control panel in a protected location.

3.8.3.3 Transport Aisles. Width of transport aisles shall be at least twice the vehicle width plus 18 inches (145 mm) to permit two-way traffic.

3.8.4 Building Bay Dimensions. Modular building dimensions (See Table 5) were developed using the systems requirements established in NAVSUP PUB-529. The universal bay size will not represent the optimum column spacing for



MIL-HDBK-1032/2

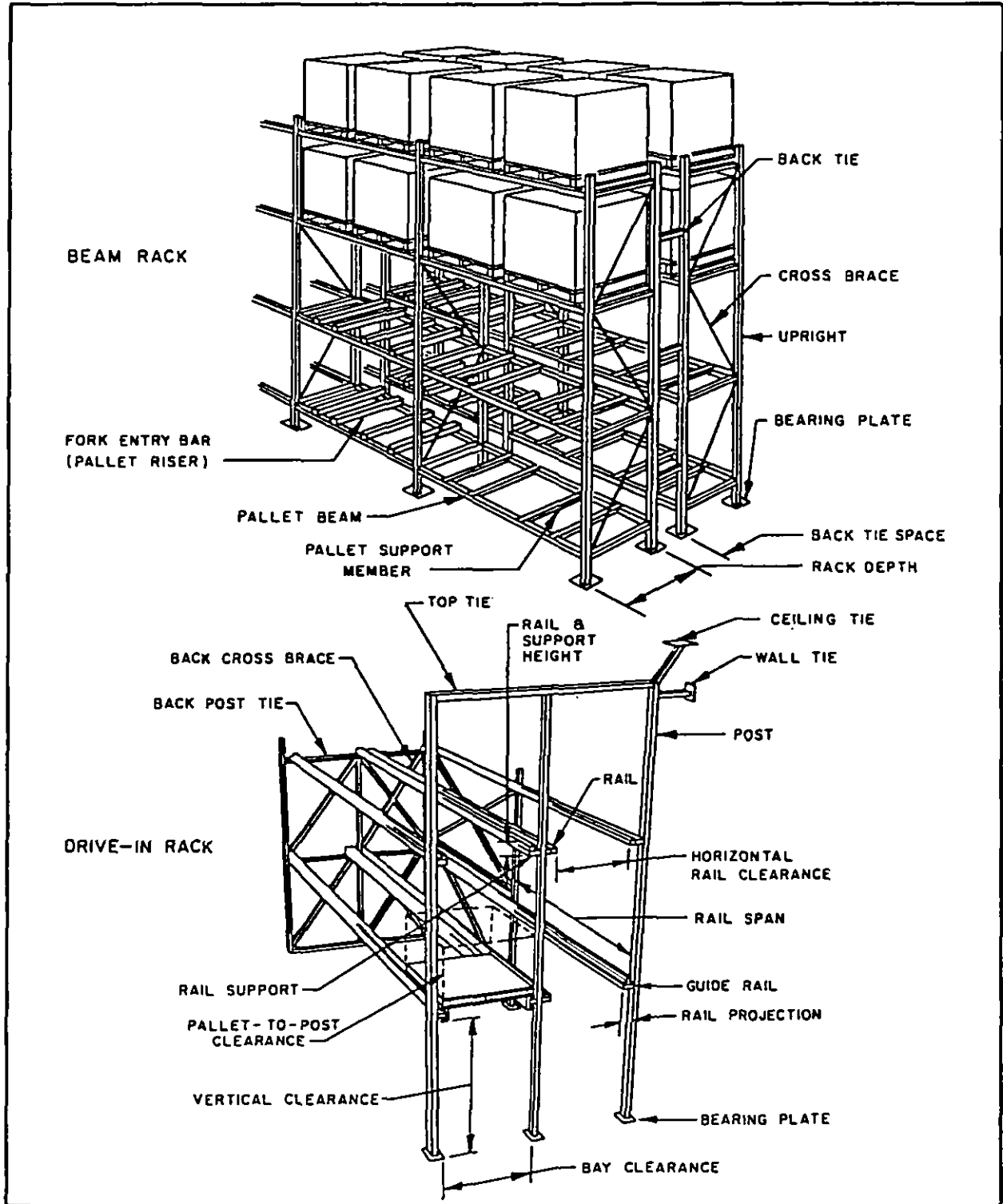

Figure 25  
Pallet Rack Terminology

MIL-HDBK-1032/2

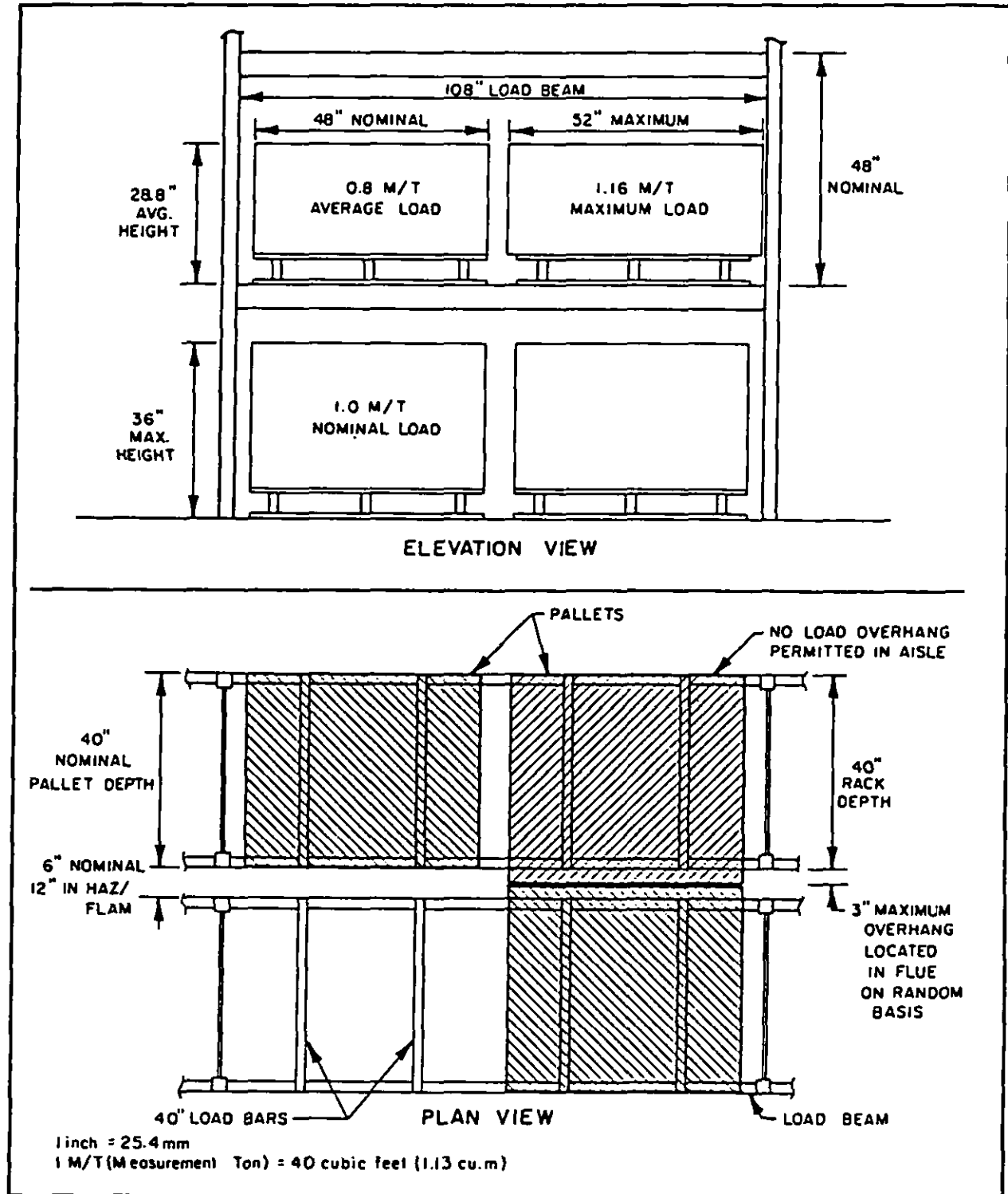

Figure 26  
 Navy/DOD Pallet Arrangement

MIL-HDBK-1032/2

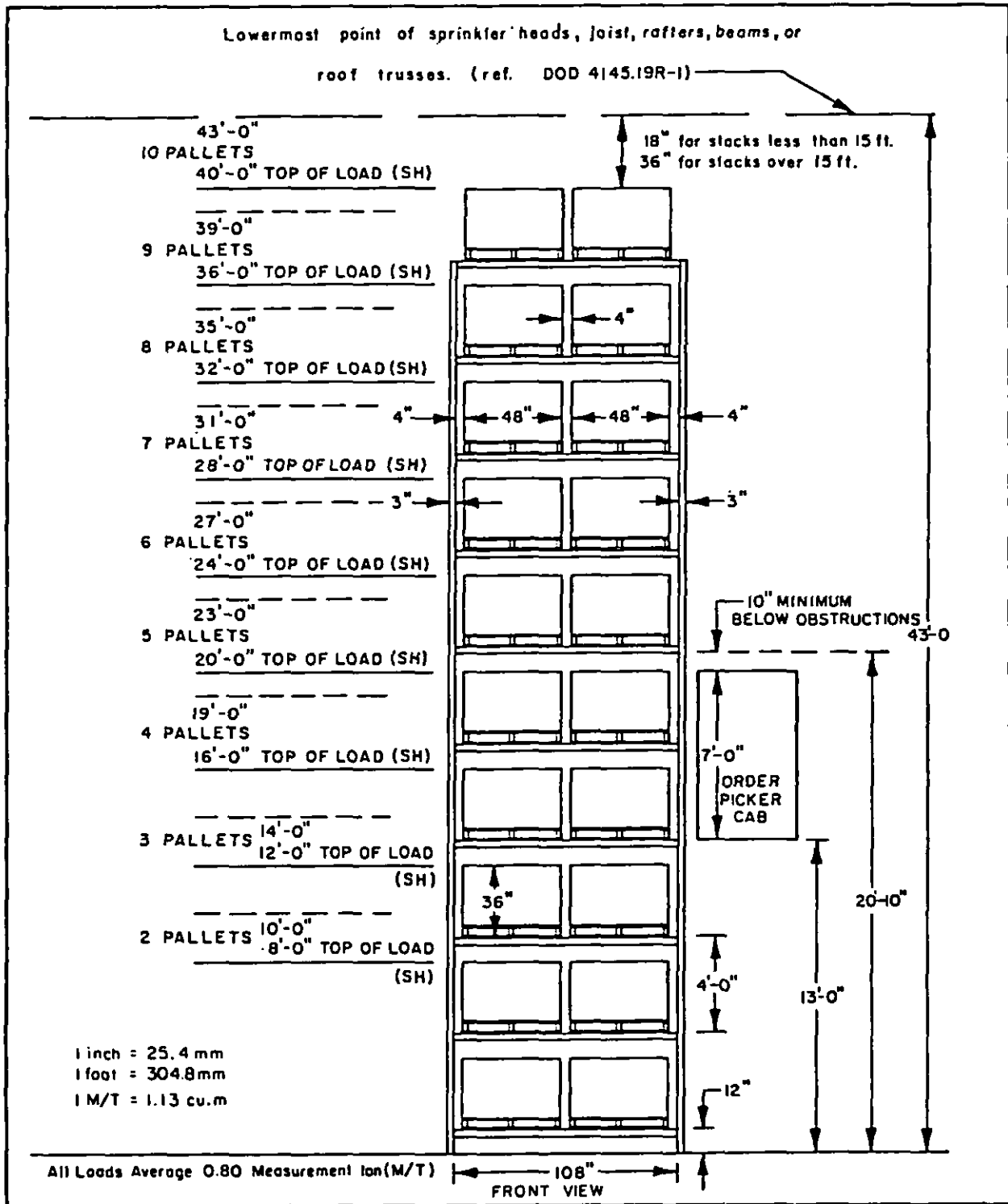

Figure 27  
Standard Pallet Rack Elevation

MIL-HDBK-1032/2

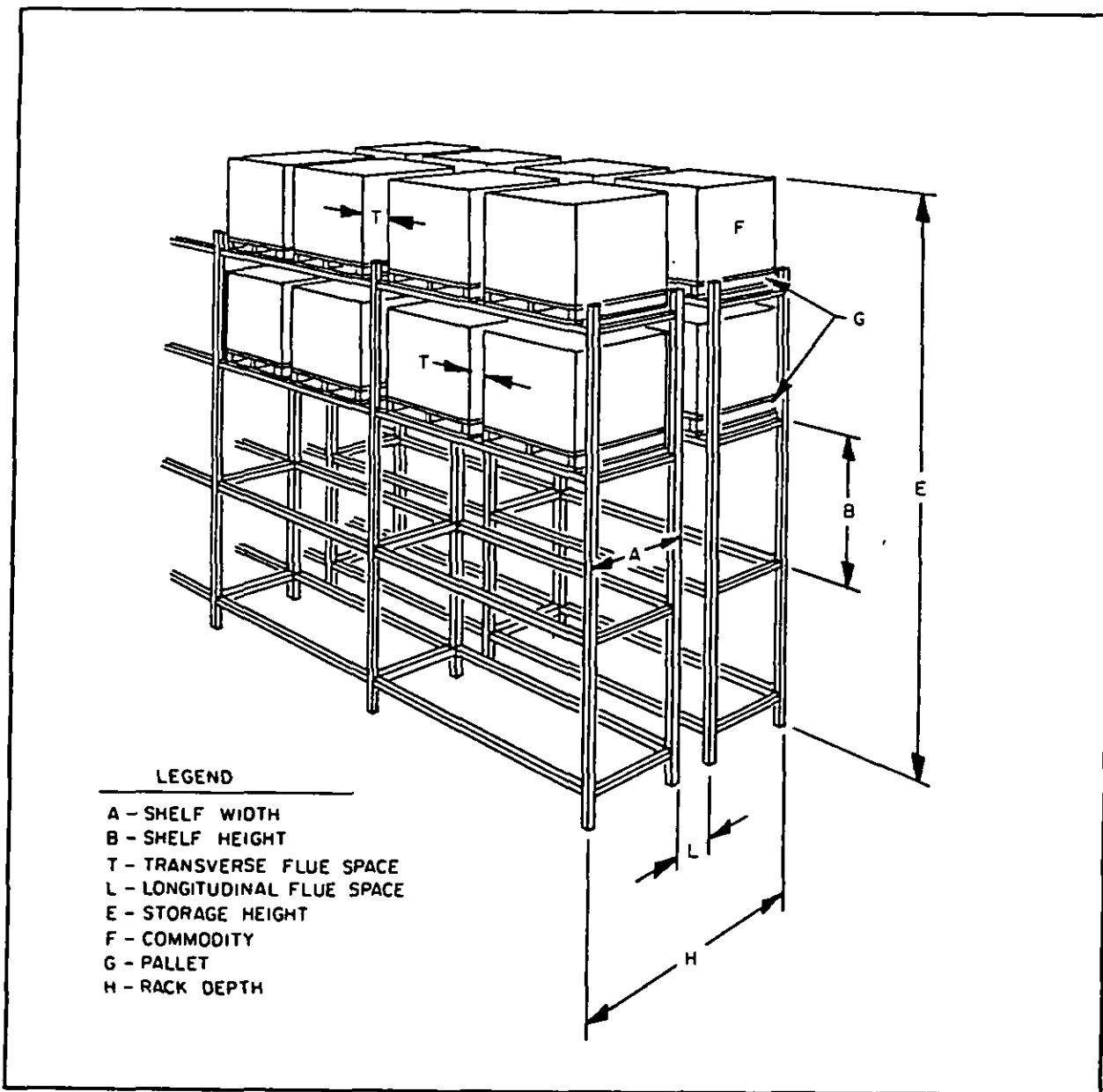

Figure 28  
Pallet Rack Fire Protection Terminology

MIL-HDBK-1032/2

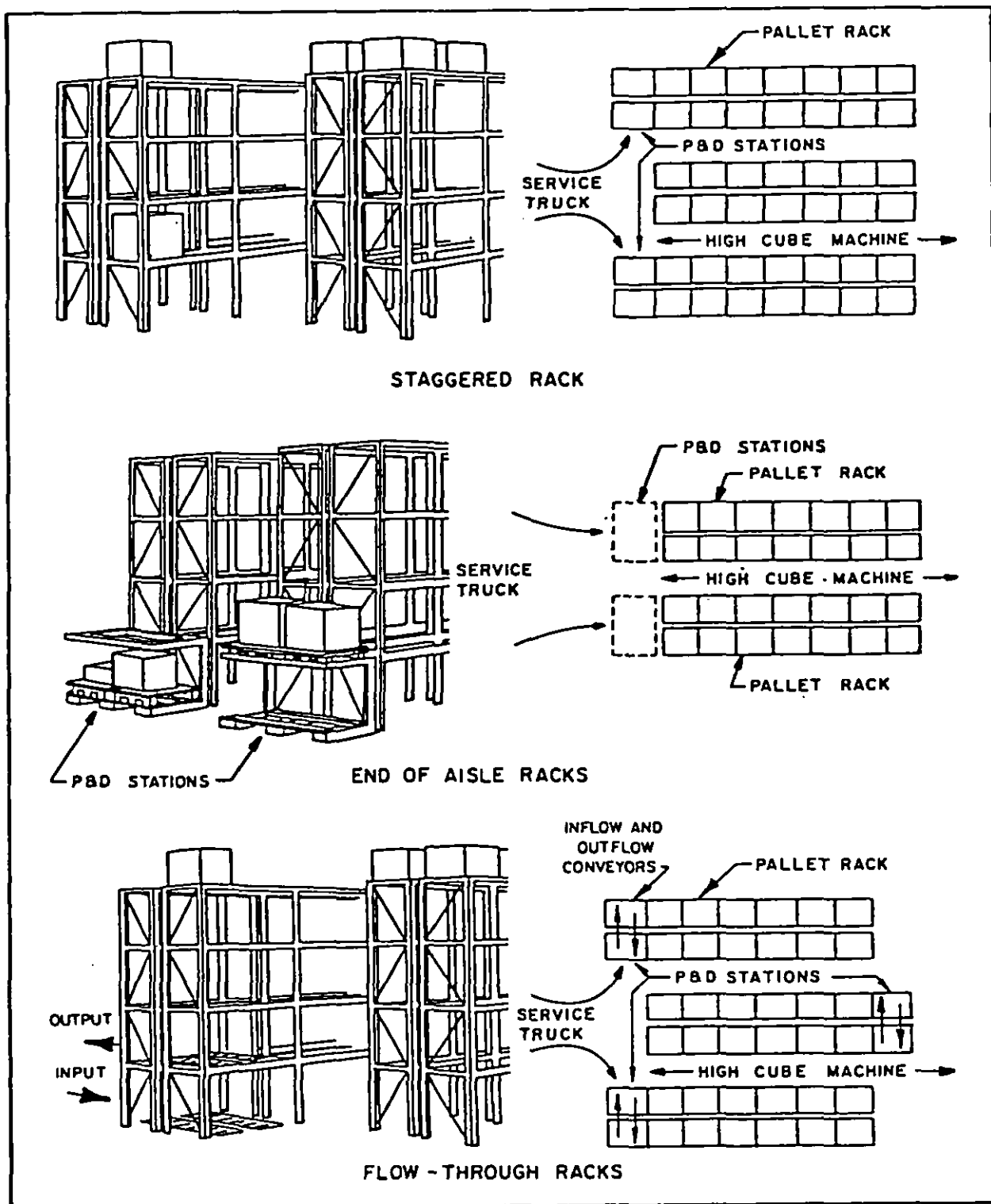

Figure 29  
Pickup and Delivery (P&D) Stations

MIL-HDBK-1032/2

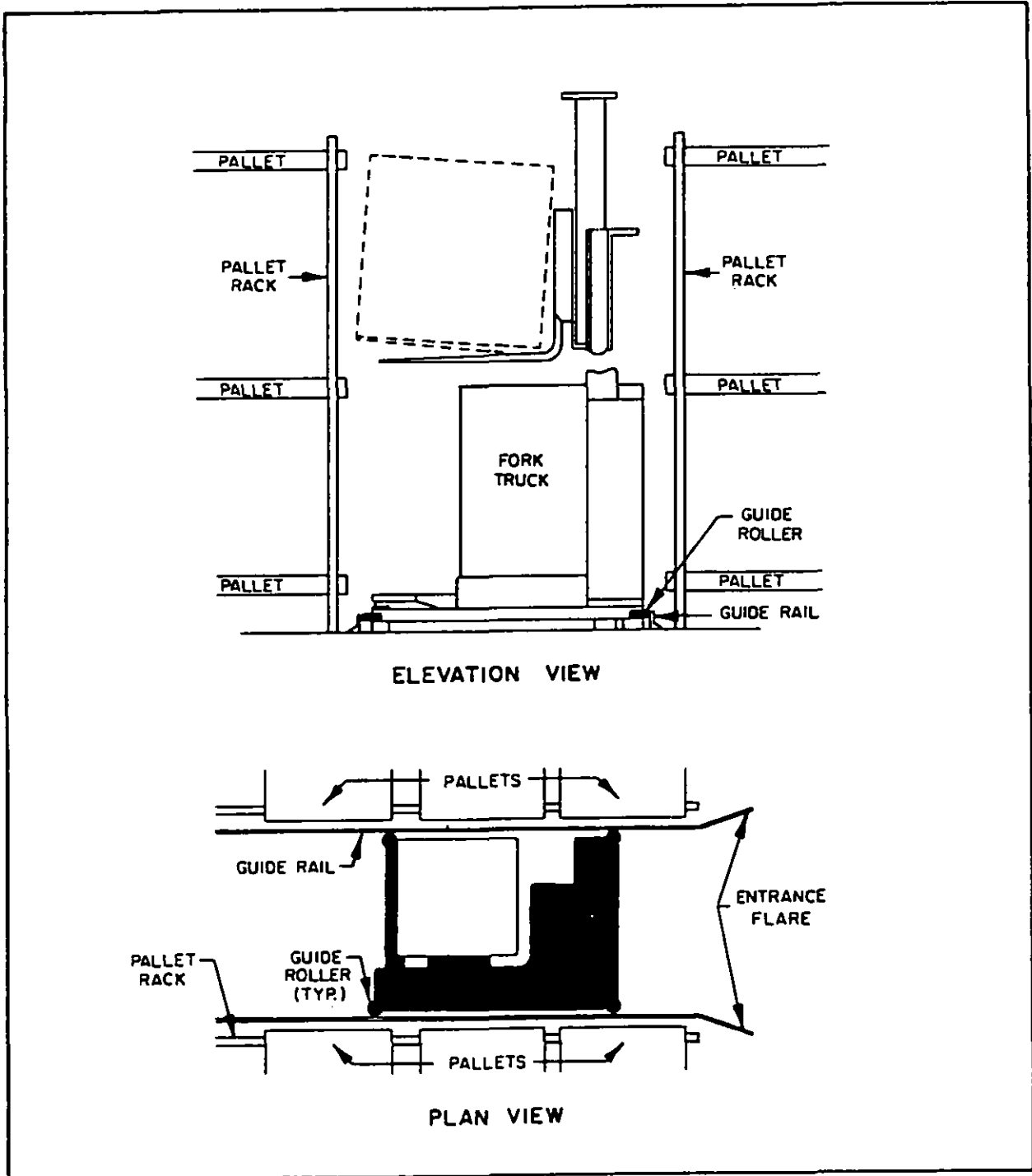

Figure 30  
Typical Rail Guidance System

MIL-HDBK-1032/2

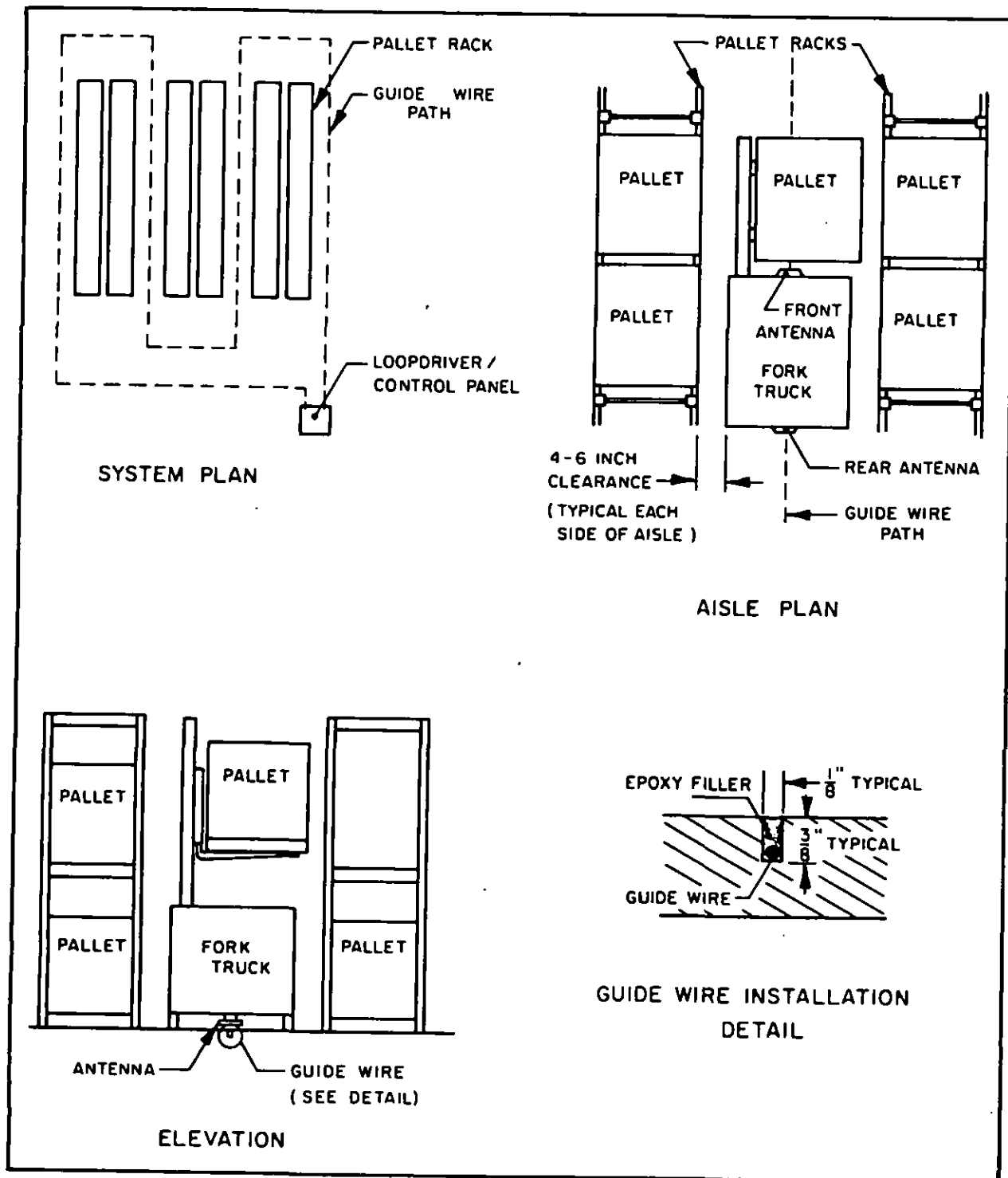

Figure 31  
Typical Wire Guidance System

Table 5  
Building Bay Size Comparison

| SYSTEM  | OPTIMUM BAY SIZE (1)                        | MODULAR EQUIVALENT BAY SIZE (2)   | BAY DIMENSION FOR FIT (3)                      | SPACE UTILIZATION IN UNIVERSAL BAY (4) |
|---|---|---|--|--|
| Counterbalance Truck  | 39'-2" x 39'-2"<br>(11 940 mm x 11 940 mm)  | 39'-2" x 58'-4"<br>(11 940 mm x 17 780 mm)  | 64'-0"<br>(19 510 mm)                          | 91.1%                                  |
| Reach Truck   | 30'-2" x 44'-10"<br>( 9 190 mm x 13 670 mm) | 30'-2" x 44'-10"<br>( 9 190 mm x 13 670 mm)<br>30'-2" x 59'-5"<br>( 9 190 mm x 18 110 mm) | 33'-0"<br>(10 060 mm)<br>64'-0"<br>(19 510 mm) | 91.4%<br>92.9%                         |
| Front/Sideloader Truck<br>Turret Truck<br>Man-Up Turret Truck | 26'-2" x 38'-10"<br>( 7 980 mm x 11 840 mm) | 26'-2" x 38'-10"<br>( 7 980 mm x 11 840 mm)<br>26'-2" x 64'-2"<br>( 7 980 mm x 19 560 mm) | 33'-0"<br>(10 060 mm)<br>64'-0"<br>(19 510 mm) | 79.3%<br>100.3%                        |
| Hybrid Truck  | 24'-2" x 35'-10"<br>( 7 370 mm x 10 920 mm) | 24'-2" x 59'-2"<br>( 7 370 mm x 18 030 mm)  | 64'-0"<br>(19 510 mm)                          | 92.4%                                  |
| Manual Order Picker   | 31'-0" x 49'-0"<br>( 9 450 mm x 14 940 mm)  | 31'-0" x 61'-0"<br>( 9 450 mm x 18 590 mm)<br>31'-0" x 61'-0"<br>( 9 450 mm x 18 590 mm)  | 33'-0"<br>(10 060 mm)<br>64'-0"<br>(19 510 mm) | 93.9%<br>95.3%                         |
| Order Picking Truck   | 33'-0" x 49'-0"<br>(10 060 mm x 14 940 mm)  | 33'-0" x 59'-0"<br>(10 060 mm x 17 980 mm)<br>33'-0" x 59'-0"<br>(10 060 mm x 17 980 mm)  | 33'-0"<br>(10 060 mm)<br>64'-0"<br>(19 510 mm) | 100.0%<br>92.2%                        |
| Manned S/R Machine  | 31'-0" x 49'-0"<br>( 9 450 mm x 14 940 mm)  | 31'-0" x 61'-0"<br>( 9 450 mm x 18 590 mm)<br>31'-0" x 61'-0"<br>( 9 450 mm x 18 590 mm)  | 33'-0"<br>(10 060 mm)<br>64'-0"<br>(19 510 mm) | 93.9%<br>95.3%                         |
| Carousel  | 32'-6" x 45'-6"<br>( 9 910 mm x 13 870 mm)  | 32'-6" x 45'-6"<br>( 9 910 mm x 13 870 mm)<br>32'-6" x 58'-6"<br>( 9 910 mm x 17 830 mm)  | 33'-0"<br>(10 060 mm)<br>64'-0"<br>(19 510 mm) | 98.5%<br>91.4%                         |
| Mini-S/R Machine  | 26'-0" x 51'-0"<br>( 7 920 mm x 15 540 mm)  | 26'-0" x 63'-6"<br>( 7 920 mm x 19 350 mm)<br>26'-0" x 63'-6"<br>( 7 920 mm x 19 350 mm)  | 33'-0"<br>(10 060 mm)<br>64'-0"<br>(19 510 mm) | 78.8%<br>99.2%                         |

Note: Standard Space Analysis Module dimensions from PUB-529 used unless otherwise noted.

- (1) From line 2(c) in Layout Planning Charts I and II, NAVSUP PUB-529.
- (2) Obtained by adding aisles to modular layout to obtain an approximate 33 feet x 64 feet (10 060 mm x 19 510 mm) bay dimension.
- (3) Dimension of the universal building bay in which the repeating rack/aisle pattern is aligned.
- (4) Ratio of Modular Equivalent dimension to Bay Dimension. Comparisons made for utilizations in excess of 75%.



## MIL-HDBK-1032/2

every system. Figure 32 illustrates column spacing parameters which affect bay dimensions. For large facilities designed for a specific system, greater utilization of building area will be obtained by selecting a column spacing matching the requirements of the material handling system. When selecting a column spacing pattern, consider the following:

3.8.4.1 Universal Bay Size. If a general purpose facility is required, or a specific materials handling system has not been selected, maintain versatility in selecting the universal pattern subject to the following considerations:

- a) The universal pattern will not represent the optimum spacing for all systems.
- b) The facility may be more costly than necessary because of the inefficient use of space. A smaller building can generally be constructed if the optimum column spacing is used.
- c) Use of the universal pattern will permit the building to fulfill a variety of missions due to its ability to function with many materials handling systems.

3.8.4.2 Optimum Bay Size. Use of the optimum bay size for a particular materials handling system will provide the most efficient use of the building area. In addition:

- a) Use of the optimum bay size will reduce the size of the required building due to more efficient use of the building cube.
- b) Ultimate versatility of the facility will be reduced because the column pattern will not fit every system.

3.8.4.3 Comparison of Bay Sizes. The information presented in Table 5 provides comparison information to enable a designer to measure the effects of changes to the building bay size. Use of the universal bay size results in an average 7 percent increase in required building area.

3.8.4.4 Clear Storage Height. For storage less than 15 feet (4570 mm) high, at least 18 inches (460 mm) is required between the top of the load and any overhead obstructions and sprinklers. For storage above 15 feet (4570 mm) high, at least 36 inches (915 mm) of clearance is required. Refer to DOD 4145.19-R-1 for details.

Clear height requirements for specific levels of storage, as well as three modular clear heights covering a range of storage levels, are summarized in Table 6. Construction of a covered storage facility to a modular height greater than that required for the desired system or level of storage will result in an unutilized cube and extra construction and operating costs.

3.8.5 Communication Systems. Provide telephones, service entrances, telephone cabinets, conduit runs, and telephone outlets. Locate at least one telephone in each office.

MIL-HDBK-1032/2

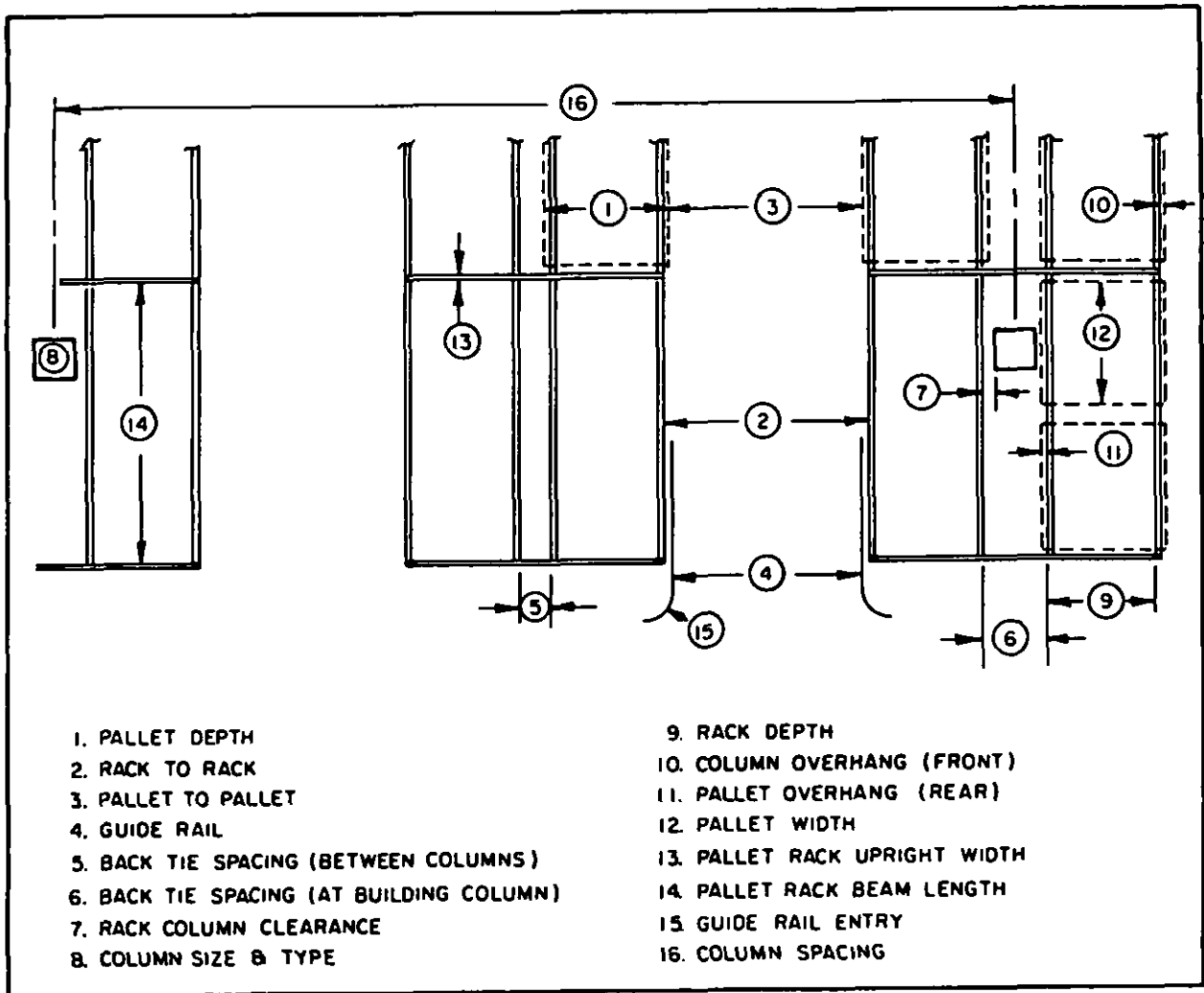

Figure 32  
Building Column Spacing Parameters

Table 6  
Required Clear Building Heights

| SYSTEM                           | PALLET STORAGE LEVELS |                   |                   |                   |                      |                     |                     |                        |                        |
|----------------------------------|-----------------------|-------------------|-------------------|-------------------|----------------------|---------------------|---------------------|------------------------|------------------------|
|                                  | 2                     | 3                 | 4                 | 5                 | 6                    | 7                   | 8                   | 9                      | 10                     |
| Counterbalance Truck             | 8'-6"<br>2590 mm      | 12'-6"<br>3810 mm | 18'-0"<br>5490 mm | 22'-0"<br>6700 mm | --                   | --                  | --                  | --                     | --                     |
| Reach Truck                      | 9'-6"<br>2900 mm      | 13'-6"<br>4110 mm | 19'-0"<br>5790 mm | 23'-0"<br>7010 mm | --                   | --                  | --                  | --                     | --                     |
| Front/Sideloader                 | 8'-6"<br>2590 mm      | 12'-6"<br>3810 mm | 18'-0"<br>5490 mm | 22'-0"<br>6700 mm | 26'-0"<br>7920 mm    | 30'-0"<br>9140 mm   | 34'-0"<br>10 360 mm | --                     | --                     |
| Turret Truck                     | 8'-6"<br>2590 mm      | 12'-6"<br>3810 mm | 18'-0"<br>5490 mm | 22'-0"<br>6700 mm | 26'-0"<br>7920 mm    | 30'-0"<br>9140 mm   | 34'-0"<br>10 360 mm | 38'-0"<br>11 580 mm    | 42'-0"<br>12 800 mm    |
| Man-Up Turret Truck              | 8'-6"<br>2590 mm      | 12'-6"<br>3810 mm | 18'-0"<br>5490 mm | 22'-0"<br>6700 mm | 26'-0"<br>7920 mm    | 30'-0"<br>9140 mm   | 34'-0"<br>10 360 mm | 38'-0"<br>11 580 mm    | 42'-0"<br>12 800 mm    |
| Hybrid Truck                     | --<br>--              | --<br>--          | --<br>--          | --<br>--          | --<br>--             | 31'-6"<br>9600 mm   | 35'-0"<br>10 670 mm | 39'-6"<br>12 040 mm    | 43'-6"<br>13 260 mm    |
| SYSTEM                           | STORAGE UNIT LEVELS   |                   |                   |                   |                      |                     |                     |                        |                        |
|                                  | 1                     |                   | 2                 | 2                 | 3                    | 4                   |                     | 5                      | Other                  |
| Manual Order Picker              | 9'-0"<br>2740 mm      | --                | 18'-0"<br>5490 mm | --                | 26'-0"<br>7920 mm    | --                  | --                  | --                     | --                     |
| Order Picking Truck              | --                    | --                | 17'-0"<br>5180 mm | --                | 24'-0"<br>7310 mm    | 31'-0"<br>9450 mm   | --                  | 38'-0"<br>11 580 mm    | --                     |
| Manned S/R Machine               | --                    | --                | --                | --                | 24'-0"<br>7310 mm    | 31'-0"<br>9450 mm   | --                  | 38'-0"<br>11 580 mm    | --                     |
| Carousel                         | 10'-0"<br>3050 mm     | --                | --                | 20'-0"<br>6100 mm | 29'-0"<br>8840 mm    | --                  | --                  | --                     | --                     |
| Mini-S/R Machine                 | --                    | --                | --                | --                | 24'-5"(1)<br>7440 mm | --                  | --                  | 34'-6"(2)<br>10 510 mm | 44'-7"(3)<br>13 590 mm |
| Modular Building<br>Clear Height | 19'-0"<br>5790 mm     |                   | 31'-0"<br>9450 mm |                   |                      | 47'-0"<br>14 330 mm |                     |                        |                        |
| Height Use<br>Efficiency         | 47% - 105%            |                   | 65% - 100%        |                   |                      | 73% - 95%           |                     |                        |                        |

## Notes:

Hybrid Truck storage above 10 levels not listed. Refer to NAVSUP PUB-529, Section 21, for details.

Clear height includes sprinkler clearance of 18" (460 mm) for stacks 15 feet (4572 mm) and less and 36" (910 mm) for stacks over 15 feet (4572 mm). Clear height does not include clearance allowances for draft curtains.

Pallet storage levels based on a standard 48" (1220 mm) vertical spacing; see alternative spacings in Appendix C of NAVSUP PUB-529.

Height use efficiency is ratio of required clear building height to modular building clear height

(1) 20 ft. (6096 mm) high system. (2) 30 ft. (9144 mm) high system. (3) 40 ft. (12192 mm) high system.

## MIL-HDBK-1032/2

3.8.6 Alarm Systems. Provide fire, hazardous chemical spill, and security alarms as follows:

3.8.6.1 Fire Alarms. Provide storage facilities with both local and fire department fire and evacuation alarms which transmit a signal to the fire department, in accordance with MIL-HDBK-1008. Equip sprinkler systems with automatic flow alarms which also activate the local fire department alarms.

3.8.6.2 Hazardous Chemical Spill Alarms. Provide hazardous chemical storage areas with alarms signalling escape or spillage of stored chemicals.

3.8.6.3 Security Alarms. Protect stored materials with security alarm systems for intrusion detection.

3.8.7 Door Clearances. Provide interior door openings of sufficient height and width to permit passage of materials handling equipment. Size truck dock doors consistent with the types of trucks expected to operate in the facility. These requirements do not apply to personnel type exit doors.

3.8.7.1 Door Height. Doors shall provide a minimum of 6 inches (150 mm) clearance for the highest loads or vehicles expected to operate in the facility. Interior doors shall be at least 10 feet (3050 mm) high. Truck dock doors shall be at least 9 feet (2745 mm) high.

3.8.7.2 Door Width. Doors shall provide a minimum of 12 inches (300 mm) clearance on each side of passing materials handling equipment. Interior doors shall be at least 6 feet (1830 mm) wide. Truck dock doors shall be at least 9 feet (2745 mm) wide.

3.8.8 Signage. Provide safety markings in accordance with the requirements of NAVFAC P-309. Typical safety markings are shown in Figure 33.

3.8.8.1 Identification. Provide identification signage to inform personnel of area identification, function, services, safety, and storage locations.

3.8.8.2 Warning. Identify all hazards, hazardous equipment, and restricted areas with suitable warning signage.

3.8.9 Pest Control. Incorporate pest control measures into building design to ensure the efficient control and quarantine of insects, rodents, and other pests. Refer to Pest Control Facilities, MIL-HDBK-1028/8. Measures shall include:

- a) Establishment of construction needs and maintenance criteria for prevention of pests.
- b) Land drainage; clearing and control of vegetation in outside storage and pest breeding areas.
- c) Application of pesticides on materials, in buildings, on the ground, and as soil treatment.
- d) Use of wood preservatives.

MIL-HDBK-1032/2

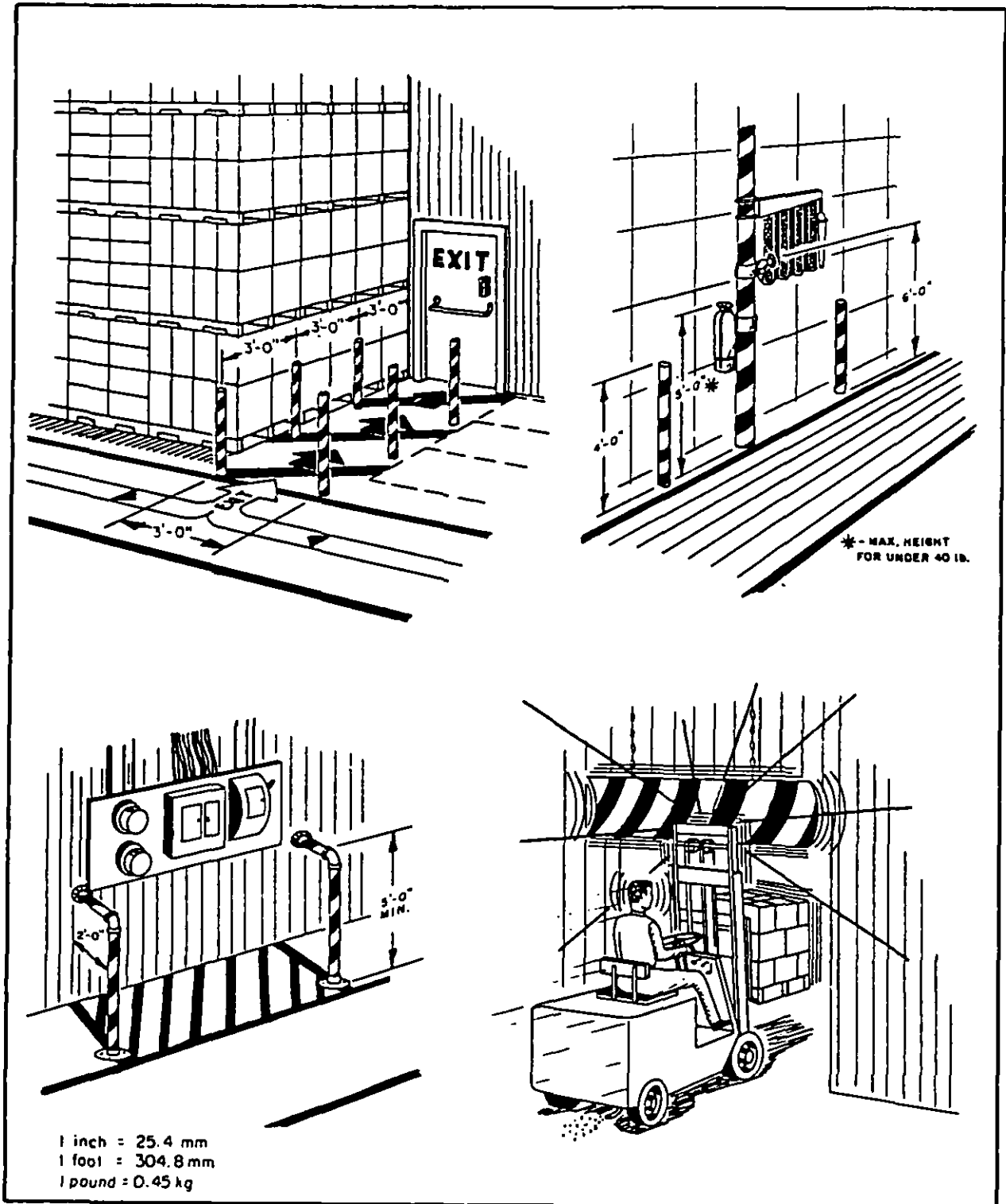

Figure 33  
Typical Safety Markings

## MIL-HDBK-1032/2

3.8.10 Design For Handicapped. Every facility shall be designed to ensure access to the handicapped unless its intended use is specifically restricted to able-bodied military or civilian personnel. Facilities shall be designed in accordance with DOD 4270.1-M and ANSI A117.1-1961(R1980). Refer to the NAVFAC Architecture Criteria Manuals for additional guidance.

3.9 Seismic Design. Determine or estimate the forces that will act on the structure and design, or specify the structure and storage equipment to resist these forces and maintain deflections within prescribed limits. Refer to NAVFAC P-355 for details on seismic design procedures.

3.9.1 Facility Loss Potential. Perform seismic design in proportion to the loss potential and importance of the facility, classified as follows:

3.9.1.1 Essential Facilities. Essential facilities house critical operations which are necessary for post-disaster recovery and require continuous operation during and after an earthquake. This includes facilities where damage from an earthquake may cause significant loss of strategic and general communications and disaster response capability.

3.9.1.2 High Risk Facilities. High risk facilities are governed by Flood Plains Management, Executive Order 11988, and DOD 4270.1-M and consist of structures in which the primary occupancy is:

- a) Assembly of a large number of people.
- b) People that are confined (e.g., prison).
- c) Services which are provided to a large area or large number of other buildings.
- d) Housing of high value equipment.
- e) Storage of fuels or hazardous chemicals.

3.9.1.3 Other Facilities. All structures not covered by the above categories.

3.9.2 Effects On Storage System Design. Seismic effects will increase the size and number of structural elements. The effect on storage equipment layout must be evaluated.

3.10 Environmental Control. Provide heating in all offices in all heating zones. Provide air conditioning in offices as permitted by Chapter 8 of DOD 4270.1-M. Determine requirements for heating in storage space based on the temperature requirements of material stored and the extent and activity level of occupancy. Need for heating of storage spaces shall be clearly demonstrated. Warehouses for storage of materials not subject to freezing shall not be heated. In warehouses containing materials subject to freezing, design heating system to maintain an inside winter temperature of 45°F (7°C). Maintain a temperature of 55°F (13°C) in warehouse areas with active employment.

3.10.1 Heating System. The heating system shall be a steam, hot water, gas fired hot air, or solar system. Provide unit heaters or hot air registers at cargo doors and over aisles between stored material.

## MIL-HDBK-1032/2

Direct-fired hot air systems shall not be used for flammable/hazardous materials warehouses. Selection of unit heaters, radiant (infrared) heaters, spot heating systems, and design of total heating systems, shall be considered on an energy and life-cycle cost basis.

3.10.2 Heating Plant. The heating plant shall be located in a heater room with no access to the storage area. When the heating plant is located inside the warehouse, the following shall be observed:

- a) Provide a wall with a 2-hour fire resistance rating between the heater room and storage area.
- b) All access to the heating area shall be from the outside only.

3.10.3 Air Conditioning. Office areas in cooling zones shall be air-conditioned by either high efficiency small area units or a central system, as appropriate.

3.10.4 Humidity Control. Appropriate humidification devices shall be considered for office heating systems to permit comfort at lower inside temperatures.

3.10.5 Energy Conservation. For descriptions, illustrations, and design criteria to be applied for energy conservation in buildings, refer to Energy Management, OPNAVINST 4100.5C.

3.10.6 Insulation. Warehousing facilities that require heating shall be insulated. Determine the amount and type of insulation by a life-cycle cost analysis. Asbestos or asbestos-based insulation shall not be used. For insulation requirements and inside design temperatures, refer to NAVFAC DM-3.03. Refer to subparagraph 6.1.6 for criteria governing cold storage facilities.

3.11 Electrical Requirements. Electrical system design and installation shall be in accordance with the NAVFAC Electrical Engineering Criteria Manuals; DOD 4270.1-M; and the requirements of the National Electrical Code, NFPA 70. Electrical requirements are as follows:

3.11.1 Illumination. Provide illumination in accordance with the recommendations in Table 7 and DOD 4270.1-M. The use of skylights and light colored floors shall be considered to supplement artificial illumination. Where possible, high efficiency lighting systems shall be used instead of conventional incandescent lights. Lighting requirements may be minimized by providing specialized lighting on the materials handling equipment, as required by the user. The following shall be observed:

- a) Position lighting fixtures directly over the storage aisles.
- b) Position lighting fixtures over the order-picking aisles or use directional lighting to illuminate the face of the storage structure.
- c) Provide task lighting for those areas requiring light levels greater than those provided for the general office area.

## MIL-HDBK-1032/2

Table 7  
Lighting Standards for Federal Supply Service Distribution Facilities

| LOCATION   | LIGHT SOURCE | LUMINAIRE TYPE    | INTENSITY Min.-Max.<br>Foot-Candles (lux) |
|--|--------------|-------------------|---|
| Active Bulk Storage (in aisles)                          | MH, HPS      | Direct            | 15 (160)                                  |
| Active Bulk Storage (stocking areas)                     | MH, HPS      | Direct            | 10 (110)                                  |
| Bin Storage (1)  | F, MH        | Direct            | 5 (50)                                    |
| Inactive Bulk Storage                                    | F, MH, HPS   | Direct            | 5 (50)                                    |
| Rack Storage   | MH, HPS      | Direct            | 20 (215)                                  |
| Mechanical Material Handling<br>Control Centers/Stations | F, MH, HPS   | Direct-Louvered   | 30 (320)                                  |
| Loading/unloading areas                                  | F, MH, HPS   | Direct-Louvered   | 20 (215)                                  |
| Accumulation Conveyor Lines (unmanned)                   | F, MH, HPS   | Direct-Louvered   | 10 (110)                                  |
| Bin Packing  | F, MH        | Direct-Louvered   | 40-50 (430-540)                           |
| Parcel Post Packing                                      | F, MH        | Direct-Louvered   | 40-50 (430-540)                           |
| Shipping   | F, MH        | Direct-Louvered   | 30-40 (320-430)                           |
| Receiving  | F, MH        | Direct-Louvered   | 30-40 (320-430)                           |
| Export Packing   | F, MH        | Direct-Louvered   | 30-40 (320-430)                           |
| Flammable Liquids (2)                                    | I, MH, HPS   | Direct            | 15-20 (160-215)                           |
| Truck Wells  | I, MH, HPS   | Direct            | 20-25 (215-270)                           |
| Truck Dock   | I, MH, HPS   | Direct            | 25-30 (270-320)                           |
| Rail Dock (3)  | I, MH, HPS   | Direct            | 20-25 (215-270)                           |
| Rail Dock Entrance                                       | MH, HPS      | Direct            | 30-40 (320-430)                           |
| Equipment Maintenance                                    | F, MH        | Direct-Industrial | 40-50 (430-540)                           |
| Battery Charging Area                                    | F, MH        | Direct-Industrial | 25-30 (270-320)                           |
| Small Storage Rooms                                      | F, MH        | Strip-Lights      | 10-15 (110-160)                           |
| Fire Alarm Stations                                      | I            | Red-100 Watt      | ---                                       |
| Exterior Lighting (4)                                    | MH, HPS      | ---               | 0.04-2.0 (0.4-20)                         |

## Key to Light Sources

MH - Metal Halide      HPS - High Pressure Sodium      I - Incandescent      F - Fluorescent

## General Requirements:

- Emergency lighting systems shall be provided and installed so that the failure of any individual lighting element cannot leave any space in total darkness.
- Foot-candle (lux) levels required are based on generally maintained intensities measured at 4 ft. (1.2 m) above the floor in space unoccupied by stock or equipment and at ground level for exterior lighting.
- Other Distribution Facility areas such as offices, laboratories, snack bars, stairways, etc., are covered in the PBS Mechanical and Electrical Engineering Handbook and/or the Illuminating Engineering Society Lighting Handbook.
- All fluorescent ballasts for indoor use shall be high power factor, rapid start, automatic reset, Class P, thermally protected type.
- Exterior lighting shall be controlled by skip-a-day type time switch.

## Notes:

- Specialized lighting designed to illuminate the bins as required is to be provided by the user.
- Fixtures and installation shall be in accordance with the requirements of the National Fire Protection Association and the National Electrical Code for the type of hazardous occupancy involved.
- Dock lights with 150-watt lamps should be provided for every 25 feet (8 m) of rail dock and for each truck dock for illumination of rail car, truck or trailer interior.
- Parking lots, maneuvering areas, outside storage, and, where required, fence lighting.



## MIL-HDBK-1032/2

3.11.2 Lighting Fixtures. Provide vapor-proof fixtures for shower rooms and explosion-proof fixtures with guards for hazardous materials storage areas. Comply with requirements of NFPA 30 and NFPA 70.

3.11.3 Receptacles. Locate convenience outlets at least every 10 feet (3050 mm) along wall space in offices and every 50 feet (15 240 mm) in all other areas.

3.11.4 Battery Chargers. Provide circuits to power battery chargers for battery-operated materials handling equipment.

3.11.5 Emergency Lighting. Provide a battery-powered emergency lighting system to provide exit and storage aisle lighting.

3.12 Plumbing Requirements. Provide plumbing fixtures and capacity in accordance with NAVFAC DM-3.01, DOD 4270.1-M, and the following:

3.12.1 Cold Water. Nominal flow rate for cold water, exclusive of fire protection requirements, shall be 55 gallons per minute (3.5 liters per second).

3.12.2 Hot Water. Provide a minimum of 30 gallons (115 liters [L]) of hot water storage capacity. Provide additional capacity for facilities requiring washdown operations.

3.12.3 Floor Drains. Provide floor drains with drain traps for general purpose and cold storage areas. A single floor drain may serve more than one area. When it is anticipated that a floor drain trap may lose its water seal because of infrequent use, means for automatically maintaining the seal shall be provided. Automatic priming of the trap may be through a drain from a fixture within the area or by a connection to the water system. When automatic priming is through a device connected to the water system, that device shall be equipped with a vacuum breaker. Floor drains are not required in service sink and transformer rooms.

## MIL-HDBK-1032/2

## Section 4: FLAMMABLE/HAZARDOUS MATERIALS WAREHOUSE

4.1 Definition. Hazardous materials storage facilities are buildings designed and constructed in accordance with the standard references listed in subparagraph 4.1.2 for storage of materials classified as hazardous to health, environment, and property, i.e., flammables, acids, caustics, oxidizers, water reactives, or others considered hazardous by the following CFR's: 29CFR - Part 1910; 40CFR - Protection of Environment; 49CFR - Parts 171-177, Hazardous Material; and Federal Standard 313B, Materials Safety Data Sheet, Preparation, and the Submission of (April 14, 1983). Refer to NAVFAC P-272, drawings 1404214 and 1404518, for typical building configurations. Section 4 provides additional specific criteria applicable to flammable/hazardous storage.

4.1.1 Compliance Standards. Comply with the following federal, industry, and association standards.

4.1.1.1 Federal Regulations. Comply with requirements of 29CFR, 40CFR, 49CFR, and Navy Hazardous Material Control Program, NAVSUPINST 5100.27.

4.1.1.2 National Fire Protection Association. The following NFPA standards shall be applied to the design, construction, and fire protection of hazardous materials storage facilities:

- a) NFPA 490 Ammonium Nitrate, Storage of
- b) NFPA 72E Automatic Fire Detectors
- c) NFPA 220 Building Construction, Standard Types of
- d) NFPA 12 Carbon Dioxide Extinguishing Systems
- e) NFPA 491M Chemical Reactions, Hazardous
- f) NFPA 49 Chemicals Data, Hazardous
- g) NFPA 16 Deluge Foam-Water Sprinkler Systems and Foam-Water Spray Systems
- h) NFPA 17 Dry Chemical Extinguishing Systems
- i) NFPA 70 Electrical Code, National
- j) NFPA 497M Classification of Gases, Vapors, and Dusts for Electrical Equipment in Hazardous Locations
- k) NFPA 68 Explosion Venting
- l) NFPA 80 Fire Doors and Windows
- m) NFPA 704 Fire Hazards of Materials, Identification
- n) NFPA 321 Flammable and Combustible Liquids, Classification
- o) NFPA 30 Flammable and Combustible Liquids, Code
- p) NFPA 325M Flammable Liquids, Gases, and Volatile Solids, Fire Hazard Properties of
- q) NFPA 12A Halon 1301 Fire Extinguishing Systems
- r) NFPA 101 Life Safety Code
- s) NFPA 78 Lightning Protection Code
- t) NFPA 72A Local Protection Signalling Systems
- u) NFPA 43C Oxidizing Materials, Gaseous, Storage
- v) NFPA 43A Oxidizing Materials, Liquid and Solid Storage of
- w) NFPA 43D Pesticides in Portable Containers
- x) NFPA 10 Portable Fire Extinguishers
- y) NFPA 72D Proprietary Protection Signalling Systems

## MIL-HDBK-1032/2

- z) NFPA 231C Rack Storage of Materials
- aa) NFPA 231D Rubber Tires, Storage of
- ab) NFPA 204M Smoke and Heat Venting
- ac) NFPA 13 Sprinkler Systems, Installation
- ad) NFPA 14 Standpipe and Hose Systems, Installation of
- ae) NFPA 231 Storage, General Indoor

4.1.1.3 Other Criteria. For cylinder storage, also observe requirements of the Compressed Gas Association Handbook of Compressed Gases, and Storage and Handling of Compressed Gases and Gas Cylinders, NAVSUPINST 4440.128B.

4.1.2 Hazardous Materials Storage Facilities. Hazardous materials storage facilities shall be designed and constructed to offer protection against the physical, health, or environmental hazards presented by the material. Storage and handling of hazardous materials shall be confined to buildings or parts of buildings meeting the requirements of this section. Mixed occupancy buildings will not house hazardous materials storage and handling operations. Under no circumstances will office buildings contain hazardous material storage and handling operations.

4.1.3 Design Criteria. Facility design and layout shall take into consideration the incompatibility of hazardous materials and hazardous material groups as described in subparagraph 4.2.2. Further guidance is provided by the applicable standards of subparagraph 4.1.1. Individual facility design and layout shall be based upon the specific types and categories of hazardous materials that are to be handled and stored. Structural and fire control system design must be approved by a registered Professional Engineer licensed in Fire Protection Engineering. Perform a system safety analysis in accordance with Military Standard System Safety Program Requirements, MIL-STD-882B, as required by Chief of Naval Operations and NAVFAC direction. Specific guidance and assistance can be obtained through NAVFAC.

4.1.4 Storage Requirements. Accommodate the following storage requirements in the design of flammable/hazardous storage facilities.

- a) The storage area shall be designed to prevent surface or groundwater contamination in the event of a spill or leak, and to capture completely each class of material individually.
- b) In acid or caustic liquid storage, a man-up type vehicle MUST be used. Otherwise, the liquids must be stored on the floor to keep the loads below the operator's eye level.

4.1.5 Materials Handling Equipment. Electrically powered materials handling equipment is the only type of powered material handling equipment rated for use in hazardous material storage areas. Use Type EE vehicles, which have all electrical equipment completely enclosed, in flammable and hazardous materials warehouses. Type EX vehicles, which have all fittings and equipment designed, constructed, and assembled for use in atmospheres containing flammable vapors, dust, and fibers, may be required for unique chemicals or applications. Verify the need for any additional requirements which may be imposed by special storage conditions.

## MIL-HDBK-1032/2

4.2 Segregation of Materials. Provide separate storage areas for materials having incompatible hazardous characteristics.

4.2.1 Categories of Materials. Normally, six categories of flammable/hazardous materials must be accommodated and provided segregated storage areas within a flammable/hazardous storage facility. Other categories may be encountered in some designs and require an additional segregated storage areas. These materials consist of the following:

4.2.1.1 Flammable and Combustible Liquids. Liquids are defined by NFPA 30 as any material having a fluidity greater than 300 penetration asphalt, when tested in accordance with Test for Penetration for Bituminous Materials, ASTM D-5-78.

Flammable liquids have a flash point below 100°F (38°C) and a vapor pressure not exceeding 40 psi absolute (275 kPa) at 100°F (38°C). These liquids are also classified as Class I liquids.

Combustible liquids have a flash point of 100°F (38°C) or higher. Combustible liquids are further classified as Class II for flash points at or above 100°F (38°C) and below 140°F (60°C), and Class III for flash points at or above 140°F (60°C).

4.2.1.2 Acids. Acids and acid mists and gases react with arsenides, borides, carbides, cyanides, fluorides, phosphides, selenides, silicides, sulfides, sulfites, and tellurides to generate toxic fumes. They also liberate hydrogen upon contact with metals and hydrides.

4.2.1.3 Oxidizers. Oxidizing materials are those chemicals which will decompose readily under certain conditions to yield oxygen. They may cause a fire in contact with combustible materials, may react violently with water, and when involved in a fire may react violently. Typical oxidizers include: organic and inorganic peroxides, permanganates, chlorates, perchlorates, persulfates, organic and inorganic nitrates, bromates, perbromates, chromates, and dichromates.

4.2.1.4 Poisons. Poisons are materials that cause death by systemic poisoning rather than by corrosive destruction of tissue. Under adverse conditions, such as a leak, spill, fire, or poor ventilation, a common chemical or compound (e.g., ammonia) may be considered poisonous.

4.2.1.5 Water Reactive Materials. These materials react with water, steam, or water solutions to produce flammable gases, toxic gases, explosive gases, or heat. Flammable gas producers include calcium, cobalt, hydrides, lithium, potassium, rubidium alloys, and sodium. Explosive gas producers include arsenides, borides, carbides, nitrides, phosphides, selenides, silicides, sulfides, and tellurides. Heat producers include acid anhydrides, concentrated acids, and concentrated alkalis. It is essential that NO water-based fire extinguishment system be used in storage areas designated for water reactive materials. Carbon dioxide or Halon systems are acceptable.

## MIL-HDBK-1032/2

4.2.1.6 Caustics. Caustics (alkalis) may liberate hydrogen upon contact with aluminum. They are not compatible with acids and should be segregated from acids for safe and efficient operations.

4.2.1.7 Organic Peroxides. Organic peroxides shall be stored in a segregated storage area, separated from all other materials.

4.2.2 Segregation Requirements. Provide for segregated storage of hazardous materials as described in NAVSUPINST 5100.27. Typical segregated storage block layouts are shown in Figure 34. Comply with the following segregation requirements:

- a) Acids shall be isolated from other materials, including chemicals within the corrosives area.
- b) Flammable liquids shall be isolated from acids and oxidizers.
- c) Organic acids shall be isolated from oxidizers.
- d) Oxidizers shall be isolated from all flammable and combustible liquids.

4.2.2.1 Compressed Gas Cylinders. Compressed gas cylinders of flammable and nonflammable gases, and gases classified as oxidizers, shall be stored in sheds and NOT in flammable/hazardous materials warehouses. Small cylinders in boxes, which are an integral part of other equipment, may be stored in flammable/hazardous warehouses, if properly segregated from incompatible materials.

4.2.2.2 Drummed POL. Drummed POL products with a flash point of more than 100°F (38°C) shall be stored in shed or open storage facilities with sealed pavements and berms/dikes to contain spills. Outside storage for drummed POL may be used, provided the drums are of corrosion resistant material or are hot-dipped galvanized for corrosion protection.

4.2.2.3 Other Materials. Dry corrosive materials, Other Regulated Materials, and radioactive materials having no other hazard, may be stored in general warehouses. All other radioactive materials shall be stored in a designated, separate area in accordance with Radioactive Commodities in the DOD Supply Systems, NAVSUPINST 4000.34B.

#### 4.3 Building Layout.

4.3.1 Relationship To Other Buildings. Siting requirements shall take into consideration adjacent buildings and the exposure hazard presented by the hazardous materials. Site drainage and spill containment systems may require increasing the minimum building separation distances prescribed in paragraph 3.3. Refer to 29CFR Part 1910.106 for additional guidance. A buffer zone of 50 feet (15.2 m) shall be provided between the facility and the nearest inhabited area, stream, or body of water.

4.3.2 Area And Height Restrictions. Warehouse areas for storage of flammable liquids or other hazardous materials shall not exceed 20,000 square feet (1858 m<sup>2</sup>) between fire walls, as stipulated in DOD 4270.1-M. Storage heights above 25 feet (7620 mm) are not permitted for flammable/hazardous

MIL-HDBK-1032/2

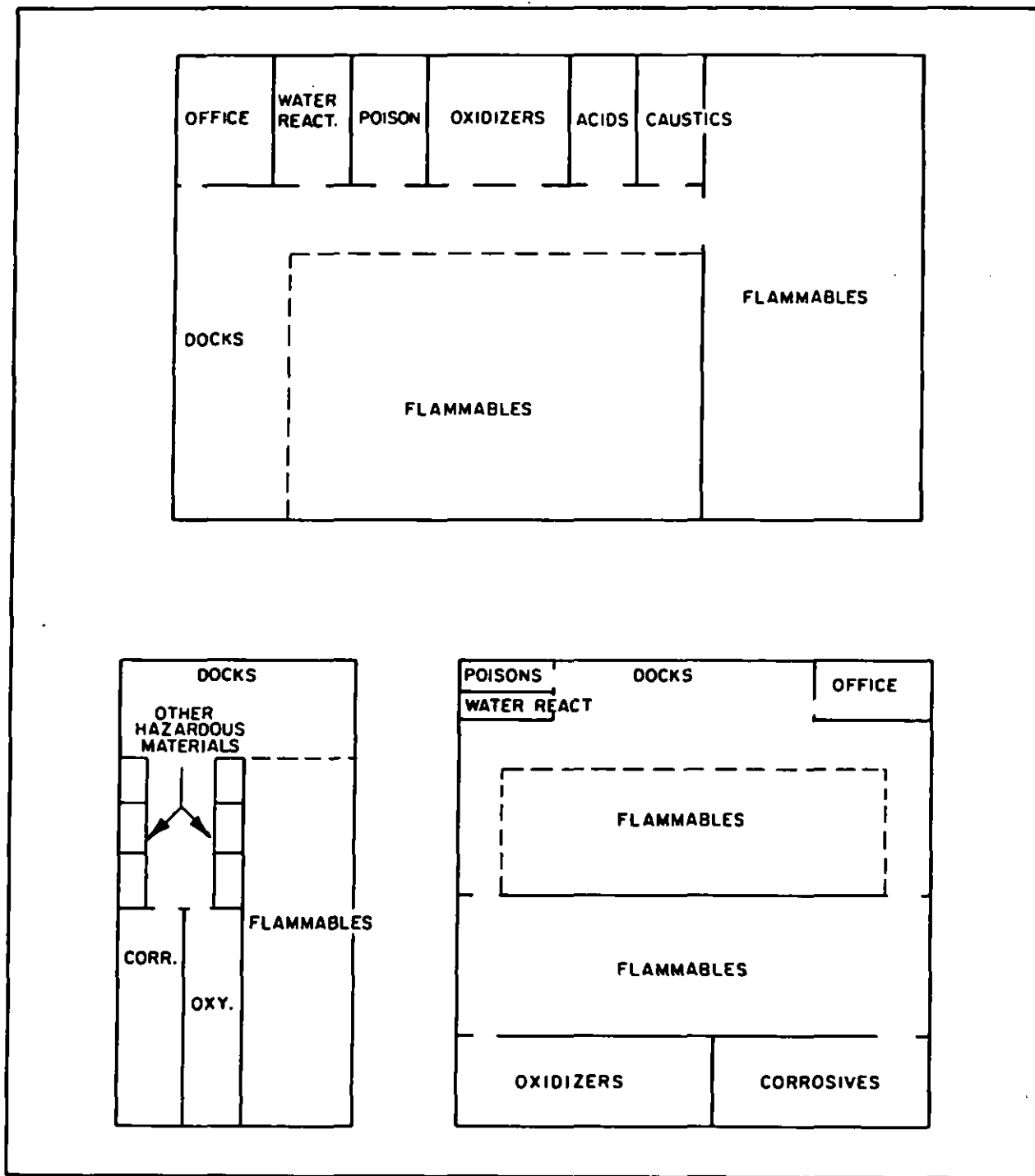

Figure 34  
Flammable/Hazardous Materials  
Storage Segregation Layouts

## MIL-HDBK-1032/2

materials warehouses by NAVSUP policy and storage restrictions of certain materials. NAVSUP policy permits man-up equipment to operate to the 25-foot (7620 mm) limit while man-down equipment is restricted to 18 feet (5490 mm).

4.3.3 Combined Shed Storage. When a flammable/hazardous materials warehouse is combined with shed storage, provide a 4-hour fire wall to separate the two storage areas. Shed and warehouse floors shall be at the same elevation, with spill containment trenches or drains at fire doors. Access to the shed shall be from the dock area of the warehouse, NOT from within a storage area.

4.4 Construction. Construction requirements for flammable/hazardous materials warehouses shall be in accordance with the provisions of DOD MIL-HDBK-1008; 29CFR Part 1910.106(d); and NFPA 30. Roofing must be specified to resist thermal expansion and twisting which may lead to roof collapse during a fire. Refer to Table 8 for general design requirements.

4.4.1 Structural Elements. Structural elements shall be noncombustible.

4.4.2 Fire Walls. Provide fire walls with a 4-hour rating to separate noncompatible storage areas from other occupancies and limit fire areas as described in subparagraph 4.3.2. Outside walls may be 2-hour rated.

4.4.3 Doors. Fire doors shall be of the rolling or sliding steel type. Where possible, eliminate fire door penetration of fire walls. Provide metal doors for personnel use.

4.4.4 Explosion Relief. In storage areas that are classified as a cut-off room or an attached building, and where Class 1-A liquids (NFPA 30) are stored in containers larger than one gallon (3.79 L), the exterior wall or roof construction shall be designed to include explosion venting features such as lightweight wall and roof assemblies, and roof hatches or windows of the explosion venting type. NFPA 68, which provides information on this subject, shall be used in conjunction with good engineering judgment.

4.4.5 Floor Coatings. Provide nonabsorbent, nonskid, corrosion, and acid resistant coatings on all flammable storage and staging area floors.

4.4.6 Showers and Eye Wash Stations. Provide emergency showers and eye wash stations within 100 feet (30.5 m) of areas inside the facility subject to potential spills.

4.4.7 Ventilation. Storage spaces for each category of hazardous material listed in Table 8 must have separate ventilation systems. Ventilation systems must provide continuous control and prevent build-up of explosive concentrations of vapors. Provide a ventilation ratio of effective vent area to floor area of at least 1:30 using roof vents or other suitable methods. Provide minimum mechanical air circulation of six air changes per hour for inside storage. Connect ventilation system to room lighting switch and supply air system. Exhaust from both the floor and roof heights. Refer to 29CFR Part 1910 and NAVSUPINST 5100.27. Ducts, fans, and other parts of systems used to ventilate corrosive atmospheres shall be of corrosion resistant construction.

Table 8  
General Requirements for Hazardous Materials Storage Facilities

| LOCATION                       | MECHANICAL<br>VENTILATION | ELECTRICAL         |                        |              | MATERIALS OF CONSTRUCTION |                   |                        | FIRE PROTECTION   |  |                      |
|--------------------------------|---------------------------|--------------------|------------------------|--------------|---------------------------|-------------------|------------------------|-------------------|--|----------------------|
|                                |                           | EXPLOSION<br>PROOF | CORROSION<br>RESISTANT | NEMA<br>TYPE | FIRE<br>RESISTANT         | NON-<br>ABSORBENT | CORROSION<br>RESISTANT | DRAINS            | SPRINKLER<br>DENSITY<br>gpm/sq ft<br>(L/s/sq. m) | EXPLOSION<br>VENTING |
| Office                         | Positive<br>Pressure      | No                 | No                     | 1            | Yes                       | No                | No                     | N/A               | 0.16 (0.10)                                      | No                   |
| Lavatory                       | Positive<br>Pressure      | No                 | No                     | 4            | Yes                       | No                | No                     | Sanitary<br>Sewer | 0.16 (0.10)                                      | No                   |
| Mechanical<br>Room             | Positive<br>Pressure      | No                 | No                     | 1            | Yes                       | No                | No                     | Sanitary<br>Sewer | 0.16 (0.10)                                      | No                   |
| Acid<br>Material               | Negative<br>Pressure      | No                 | Yes                    | 7            | Yes                       | Yes               | Yes                    | Captured          | 0.35 (0.23)                                      | No                   |
| Caustic<br>Material            | Negative<br>Pressure      | No                 | Yes                    | 7            | Yes                       | Yes               | Yes                    | Captured          | 0.35 (0.23)                                      | No                   |
| Reactive<br>Material           | Negative<br>Pressure      | Yes                | Yes                    | 7            | Yes                       | Yes               | Yes                    | Captured          | Dry  | Yes                  |
| Oxidizer<br>Material           | Negative<br>Pressure      | Yes                | Yes                    | 7            | Yes                       | Yes               | Yes                    | Captured          | 0.35 (0.23)                                      | No                   |
| Flammable<br>Material          | Negative<br>Pressure      | Yes                | Yes                    | 7            | Yes                       | Yes               | Yes                    | Captured          | 0.35 (0.23)                                      | Yes                  |
| Other<br>Regulated<br>Material | Negative<br>Pressure      | No                 | No                     | 4            | Yes                       | Yes               | Yes                    | Captured          | 0.35 (0.23)                                      | No                   |



## MIL-HDBK-1032/2

4.4.8 Lightning Protection. Protect structures against lightning damage in accordance with NFPA 78.

4.4.9 Alarms. Provide hazardous chemical storage areas with alarms signalling escape or spillage of stored chemicals.

4.5 Spill Containment and Control. Means of providing containment and removal must be provided in the event of spills.

4.5.1 Dikes. Dikes shall be used for containment of spills for commodities stored or handled outside of buildings. In accordance with NFPA 30, their volume shall be not less than the greatest amount of liquid that can be released from the largest storage container within the diked area.

4.5.2 Floor Trenches and Capture Systems. A continuous floor trench with grating (see Figure 35) shall be used at all doorways for the capture and control of hazardous chemical spills. All spill containment systems shall provide separate containment as described in subparagraph 4.5.4. Secure grate frame support channels to concrete floors. Grate design shall provide for the ability to latch the removable grate sections at aisle crossings and cargo doors to ensure that grates will remain firmly in place when material handling equipment moves over them. The cross section of the grate frame members shall be "Z-", rather than "L-", shaped so that two legs of the "Z" form a pocket for grates and the third leg is in the horizontal plane at floor level, as illustrated in Figure 35. This protects the edges of concrete around grate frames from impact damage from the wheels of materials handling equipment.

4.5.2.1 Electronic Guide Wire Crossing. When floor-buried electronic guide wire is used to guide material handling vehicles through trench grates that cross aisles or are at cargo doors, use a nonmagnetic grate section extending at least 6 inches (150 mm) on each side of the wire path so that the magnetic field of the guide wire is not distorted by passing the wire through a ferrous or magnetic grate. Alternatively, use slotted drains and pass the guide wire under the drains and shield the guide wire when passing through ferrous or magnetic grates or drains. Figure 36 illustrates typical crossing methods.

4.5.2.2 Personnel Exits. Raise personnel exit doors 6 inches (150 mm) above the floor to prevent escape of spilled liquids. Where a trench passes in front of a personnel door, use solid plates instead of grating to prevent a fire in the trench from blocking the exit door.

4.5.3 Recessed Floors. When required for specific design or containment needs, interior storage floor surfaces may be recessed 6 inches (150 mm) below the level of adjoining dock, office, and support areas to prevent the flow of spilled hazardous liquids into these areas. Vehicle access ramps shall be provided at all doorways into such areas. The use of this method is discouraged due to operational inefficiencies and the additional space requirements caused by the ramps.

MIL-HDBK-1032/2

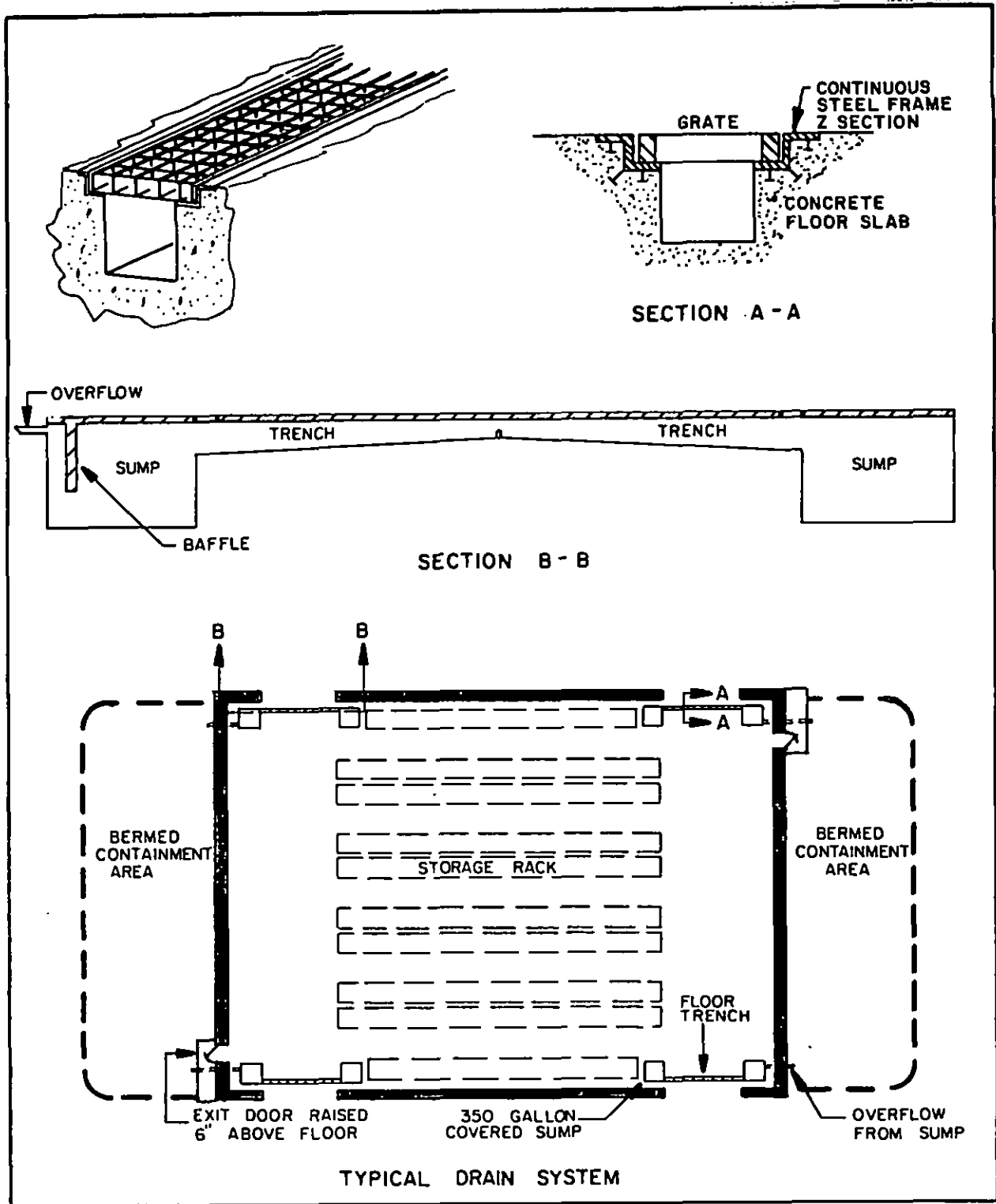

Figure 35  
Spill Capture/Containment System

MIL-HDBK-1032/2

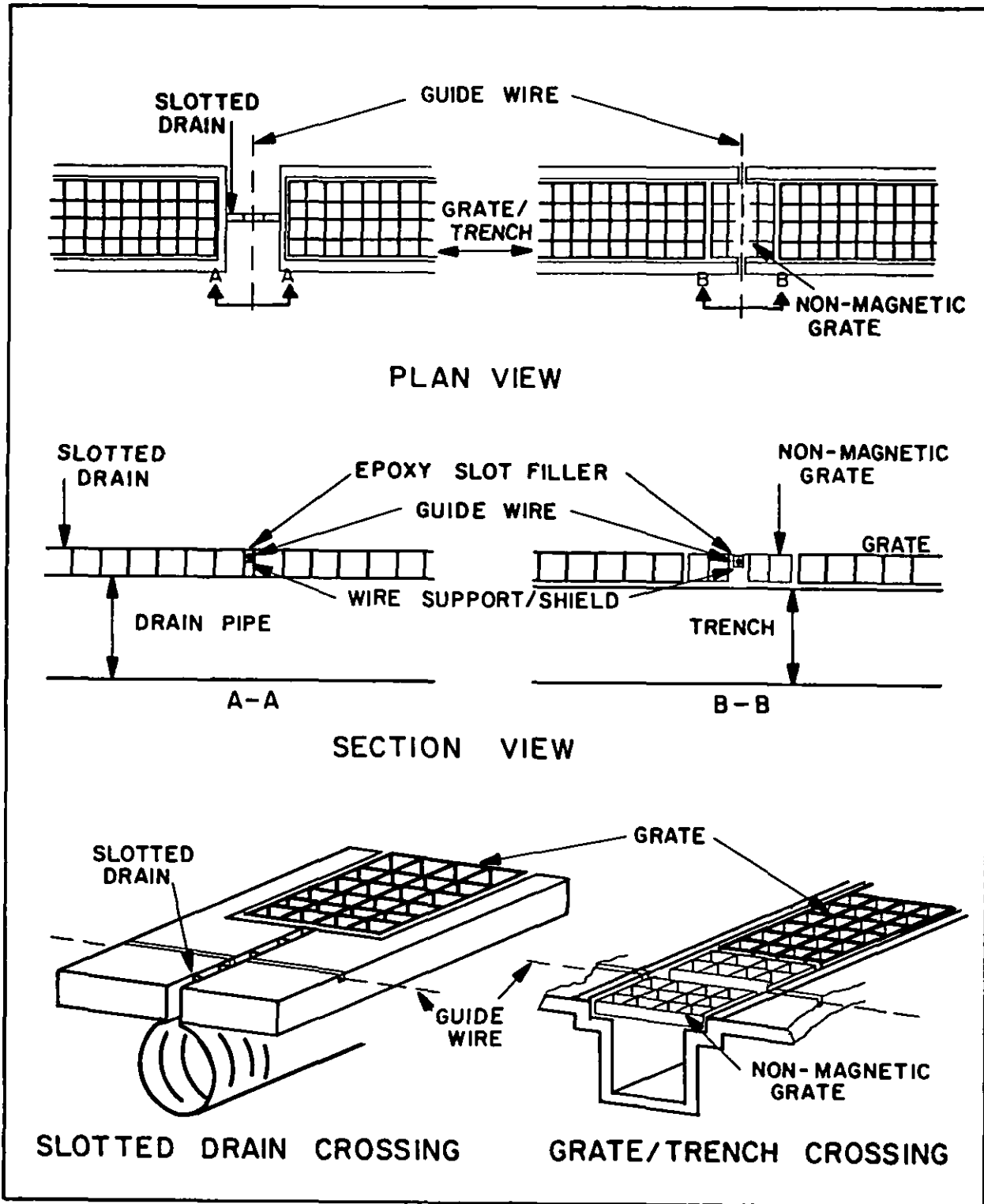

Figure 36  
Electronic Guide Wire Crossing

## MIL-HDBK-1032/2

4.5.4 Containment. Use grate-covered interior 350 gallon (1323 L) sumps in conjunction with the trench system to provide spill or leakage containment for the lesser of 1,000 gallons (3785 L) or 10 percent of the total free flowing liquid volume of all containers stored in each room. Provide a containment capacity of 1,000 gallons (3785 L) at the truck apron adjacent to the shipping and receiving area. Include a controlled flow system to prevent spilled or leaking materials from entering the storm drainage system, stream, or body of water.

4.5.5 Drainage. Install pallet racks and associated mechanical vehicle guidance systems so as to permit the unimpeded flow of spilled liquids to collecting trenches. Maintain floor flatness requirements. Floor drains shall not be installed in the storage areas of flammable/hazardous warehouses.

4.6 Automatic Fire Suppression Systems. Provide all areas with automatic fire suppression systems.

4.6.1 Design Requirements. System design shall comply with the requirements of MIL-HDBK-1008; Low Expansion Foam and Combined Agent Systems, NFPA 11; NFPA 12; NFPA 13; NFPA 30; NFPA 231; NFPA 231C; and 29CFR Part 1910. Water demand for sprinklers shall be based on hydraulic design of the system. Sprinkler heads shall be suitable for installation in a corrosive environment. Storage areas for water reactive materials shall be protected by a bromotrifluoromethane (Halon 1301) or carbon dioxide fire extinguishing system. Where nonwater systems are used, provide a 30-second audible warning prior to system activation. Provide automatic local fire department signaling upon system activation.

4.6.2 Sprinkler Adjustment. Provide adjustment of sprinkler positioning through use of mechanical grooved piping rather than threaded pipe fittings, as illustrated in Figure 21. Contact the Navy Warehouse Utilization Program at NAVSUP for guidance in specific applications.

## MIL-HDBK-1032/2

## Section 5: HEAVY MATERIALS WAREHOUSE

5.1 Definition. Heavy materials warehouses are facilities designed for the storage and handling of loads which exceed the average size and weight of Navy standard pallets. Such facilities are usually associated with manufacturing/fabrication or steel storage. Overhead handling devices such as bridge cranes are important elements in the design of these facilities. Refer to NAVFAC P-272, drawing 1404213, for a typical configuration. Section 5 provides additional specific criteria applicable to heavy materials storage.

5.2 Construction. Observe the following requirements:

5.2.1 Doors/Windows. Provide windows for office and service structures. A narrow row of windows shall be considered along the top of exterior walls to supplement electric illumination.

5.2.2 Floors. Design concrete floors for the expected load conditions. Minimum floor thickness shall be 6 inches (150 mm). Provide reinforcement for crack control or incorporate alternative methods of crack control. Increased floor thickness may be required for areas subject to heavy loading. Special toppings or hardening compounds may be specified for areas subjected to extreme loading, traffic conditions, or requiring the use of air film transporters.

5.2.3 Craneways. Design craneways for the intended load capacity and type equipment to be used. Craneway location shall avoid interference with the building structure or areas of personnel activity. Provide clearance between adjacent cranes and between the crane and the building structure.

5.3 Site Planning. The location of a heavy materials warehouse will be determined by the source of materials, the destination of materials, associated shop operations, and internal shop operations required to rough size material before being sent to its destination. Consider the following:

5.3.1 Rail Access. Building location will be affected by the ability to provide rail access from nearby tracks. The possibility of running a track through the building shall be considered. Inside tracks shall be at floor level and be equipped with crossing plates to provide a continuous, smooth crossing over the entire length of the track. A rail pit, placing the car floor at the building floor level, is not recommended since such a pit will divide the warehouse and prevent efficient use of the facility.

5.3.2 Truck Access. Provide truck dock and apron space for truck access to the building. A combination of floor level drive-in doors and docks with dock levelers shall be provided to handle any combination of vehicles. Drive-in doors should accommodate flatbed and semi-trailers and be located to permit overhead crane loading and unloading.

5.3.3 Expansion. Provide for expansion in proportion to the requirements expected of the associated operations to be supported by the heavy materials warehouse. Provisions shall be made for the expansion of the building width and length to accommodate growth.

## MIL-HDBK-1032/2

## Section 6: COLD STORAGE WAREHOUSE

6.1 Definition. Cold storage facilities are buildings designed and constructed to provide preservation of the quality of perishable foods and general supply materials requiring refrigeration. Such facilities will include freeze and chill space, mechanical areas, and may contain inspection and processing facilities. Refer to NAVFAC P-272, drawing 1404208, for typical configurations. Section 6 provides additional specific criteria applicable to cold storage.

6.2 Construction. Refer to Mechanical Engineering, Refrigeration Systems for Cold Storage, NAVFAC DM-3.04, for criteria relating to the design, installation, and operation of refrigeration systems not otherwise defined in this handbook. Observe the following:

6.2.1 DOD Requirements. Comply with DOD 4270.1-M for building heat gain maximums, equipment, and vapor barriers. Comply with requirements of Section 4 if storage of hazardous or flammable materials is required.

6.2.2 Construction Details. Refer to Appendix A for illustrations of typical cold storage construction and insulation methods.

6.2.3 Doors/Windows. Fenestration is not permitted in storage areas. Use security-type windows with wire glass in offices, equipment rooms, toilets, and locker areas. Cold storage doors shall open from inside as well as outside.

6.2.4 Floors. All finished floors shall be at one level to avoid the use of steps or ramps. Floors of different rooms may have different insulation thicknesses. Differences in insulation thicknesses shall be adjusted by the level of the rough floor slabs. Provide under floor heating for slab-on-grade floors as required by local conditions.

6.2.5 Floor Drains. Provide floors with drains to permit periodic washdown and cleaning operations. Floor drains shall not be located in storage aisles. The floor shall not slope toward drains. Floor flatness requirements must be maintained.

6.2.6 Insulation. Insulate all refrigerated structures and the low temperature piping and mechanical equipment. Insulation must have a flame-spread rating of 75 or less or the entire panel must be Underwriters Laboratory (UL) or Factory Mutual approved as a noncombustible building unit. Insulation shall have a smoke developed rating of 100 or less. Refer to NAVFAC DM-3.04 for criteria on insulation.

6.2.6.1 Cost of Insulation. In cold storage plants, the cost of insulation of cold storage rooms constitutes a substantial part of the total cost of the installation. Prepare an Economic Analysis in accordance with NAVFAC P-442 to determine optimum insulation thickness for cold storage buildings.

## MIL-HDBK-1032/2

6.2.6.2 Selection. The selected thickness and type of insulation shall result in minimum total life-cycle cost over the 25-year life of the structure. For methods of determining the economic thickness, refer to the American Society of Heating, Refrigeration, and Air Conditioning Engineers (ASHRAE) ASHRAE Handbook, Fundamentals.

6.2.6.3 Mechanical Protection for Insulation. Provide mechanical protection for insulation using exterior finishes described in subparagraph 6.2.8. Otherwise, provide an auxiliary means of protection. The following factors are significant in assuring insulation integrity.

a) Chemical Compatibility. Interior finishes shall be chemically compatible with the surfaces to which they are applied.

b) Fire Retardance. Interior finishes shall have a flame-spread rating of 75 or less and a smoke developed rating of 100 or less. Comply with DOD 4270.1-M and DOD MIL-HDBK-1008.

c) Protection from Direct Water Entry. Interior finishes shall provide protection from the direct entry of water during washing and cleaning operations.

d) Freedom from Rot, Corrosion, and Odor. Interior finishes shall neither absorb nor impart any odors to the stored product. Finishes shall not be susceptible to decay caused by corrosion or rotting.

e) Repairability. Interior finishes shall be repairable at the operating temperature of the refrigerated room or structure.

6.2.7 Exterior Finishes. Provide for expansion and contraction of the building structure. Outer surfaces shall be designed to effectively withstand prevalent conditions of weather, wind load, and corrosive environment. Exterior finishes shall be fire resistant, water proof, and prevent the entry of vermin. When the exterior surface is used as the vapor barrier, design details shall include the recommendations listed in subparagraph 6.2.9.

6.2.8 Interior Finishes. Interior finishes shall mount apart from the insulation. Interior finishes shall have a permeance significantly greater than that of the vapor barrier system. No interior finish shall be used that may cause contamination of stored products. Interior surfaces shall meet health and sanitary regulations applicable to the intended storage and facility use. The appearance of the interior finish shall be considered secondary to its meeting of functional requirements.

6.2.9 Vapor Barrier System. Every installation shall be protected by a vapor barrier system. Vapor barriers shall be placed on the warm side of the insulation and be covered to prevent damage. Conditions of reverse vapor flow; in which temperature vapor conditions are reversed from normal operating conditions, shall be accounted for. Such conditions may typically occur in climates where the refrigerated-space temperature may become greater than the outside temperature, thus reversing the normal temperature pattern. Vapor barrier systems shall be capable of withstanding expansion and contraction in any direction without developing heat, air, or vapor leaks. Permeance shall be no more than 0.1 perm. Vapor barrier systems shall have a minimum life expectancy of 25 years. Special attention shall be given to designs in humid climates where vapor transmissions are a significant problem.

## MIL-HDBK-1032/2

6.2.10 Sealants, Fasteners, and Adhesives. Sealants, fasteners, and adhesives used for installing insulation shall not impair the integrity of the vapor barrier system. Metal skewers shall not be used as fasteners. Adhesive and sealants shall not be used in multilayer construction in a manner that will create restrictive vapor dams which may cause internal condensation and possible frost formation. Fasteners and adhesives shall be applied only to reasonably smooth surfaces.

6.2.11 Built-up Roofing Over Deck Insulation. The extreme conditions under which a built-up roofing system must operate when over a cold storage facility increases the possibility of failure. Installation of built-up roofing over cold storage areas shall be incorporated as part of the cold room insulation work to permit a more forceful coordination and inspection of the roofing that is applied over the insulation.

6.2.12 Doors. Door heaters shall be included when needed to prevent frost and moisture accumulation on door gaskets. Also reconsider recirculating air curtains on both sides of all doors between areas of differing temperature.

6.2.13 Refrigeration Systems. Refer to NAVFAC DM-3.04 for guidance on the selection of refrigeration systems for cold storage warehouses.

6.2.14 Special Equipment Ratings. Cold storage equipment conditioning includes hydraulic, mechanical, and electrical modifications for trucks which will be used in cold storage applications. Class I conditioning, consisting of special condensation protection, shall be applied to trucks operating in an environment where temperatures fluctuate from normal warehouse ambient temperature to 32°F (0°C). Class II conditioning, consisting of battery heaters, hydraulic system modifications, and condensation protection, shall be applied to trucks operating in an environment where temperatures fluctuate from normal warehouse ambient temperature to -40°F (-40°C) or where continuous operation at temperatures of 32°F to -20°F (0°C to -29°C) is expected.

6.2.15 Alarms. Cold storage facilities shall be equipped with safety, security, and high temperature alarms.

6.2.15.1 Safety Alarm. Each room shall have a pushbutton wired to an alarm bell outside the room and to a location manned or monitored on a 24-hour basis so that any person locked inside the room can call for help.

6.2.15.2 Security Alarm. When a security system is present, alarms shall be installed to indicate unauthorized entry to the building or individual storage rooms.

6.2.15.3 High Temperature Alarm. Alarms to indicate compressor faults or excessive temperature in cold storage spaces shall be located both locally and in the office or other supervisory area. Panel-mounted alarm lights with audible alarms and manual silencing switches shall be provided for each room and for each compressor.



## MIL-HDBK-1032/2

6.3 Sprinklers. Sprinklers shall be installed in all storage, operation, and equipment areas.

6.3.1 Design Requirements. Provide a dry pipe sprinkler system or dry pendant sprinkler heads for refrigerated spaces. Provide wet pipe systems in other areas. Design sprinkler systems in accordance with MIL-HDBK-1008, NFPA 13, NFPA 231C, and subparagraph 3.7.5. Storage over 12 feet (3660 mm) must also comply with NFPA 231.

6.3.2 Drainage. Pallet racks and any associated mechanical vehicle guidance systems shall be installed in such a manner so as to permit the unimpeded flow of liquids to collecting drains.

6.3.3 Floor Flatness. Floor flatness requirements dictate that the floor remain level at floor drains. Depressions shall NOT be made in the floor to channel flow to the drains as such depressions will interfere with material handling equipment operation. Floor drains shall be located under the pallet racks and NOT in the storage aisle.

6.4 Electrical Requirements. Requirements for electrical systems are as follows:

6.4.1 Lighting Fixtures. Provide vapor-proof fixtures with guards for all refrigerated spaces. Consider the use of high pressure sodium lighting for bay areas. Consider the use of mineral insulated-type cable in refrigerated spaces.

6.4.2 Illumination Levels. For refrigerated spaces, provide a lighting level of 10 footcandles (107.6 lux) 4 feet (1200mm) above the floor, with additional lighting provided on the materials handling vehicle. Provide levels of illumination for all other areas as defined in subparagraph 3.11.1 and DOD 4270.1-M.

6.4.3 Other Equipment. Provide electrical service for the following:

- a) Power-operated doors.
- b) Refrigeration compressors.
- c) Material handling equipment battery chargers.
- d) High temperature alarm for refrigerated areas.

6.5 Inspection Area. For large activities, provide a veterinary inspection area with fork truck access to permit inspection of incoming goods. For activities with resident veterinarians, inspection facilities (lab and office) shall be provided in accordance with Defense Personnel Subsistence Center requirements.

6.6 Storage Requirements. Pallet storage capacity depends on the number of personnel and the number of days of storage to be served by the building (See Table 9). To conserve space and use the maximum storage height, pallet racks and narrow aisle fork trucks shall be used.

## MIL-HDBK-1032/2

Table 9  
Pallet Storage Quantities for Cold Storage Warehouses

| STORAGE<br>LOCATION                       | PALLET REQUIREMENTS             |                     |                                   |                     |              |
|---|---------------------------------|---------------------|-----------------------------------|---------------------|--------------|
|   | Daily Receipts<br>of Bread/Milk |                     | Monthly Receipts<br>of Bread/Milk |                     |              |
|   | Days of<br>Supply               | Percent of<br>Total | Days of<br>Supply                 | Percent of<br>Total |              |
|   | 10                              | 30                  | 30                                |                     |              |
| Freeze -5°F (-21°C)                       | 9                               | 27                  | 34.6                              | 51                  | 50.0         |
| Chill +35°F (+2°C)<br>(Cured meats/dairy) | 7                               | 21                  | 26.9                              | 21                  | 20.6         |
| Chill +35°F (+2°C)<br>(Other)             | 4                               | 12                  | 15.4                              | 12                  | 11.8         |
| Chill +50°F (+10°C)                       | 6                               | 18                  | 23.1                              | 18                  | 17.6         |
| <b>TOTAL</b>                              | <b>26</b>                       | <b>78</b>           | <b>100.0</b>                      | <b>102</b>          | <b>100.0</b> |

Notes:

Data excludes refrigerated requirements for storage of film, batteries, medical supplies and other nonsubsistence items.

Pallet quantities and percentages are for use in the absence of other data based on experience. Assume that each pallet load of subsistence averages approximately 1 M/T or 40 ft<sup>3</sup> (1.1 m<sup>3</sup>). On the basis of this assumption, multiplying the pallets required for a 30-day supply by 40 ft<sup>3</sup> (1.1 m<sup>3</sup>) gives totals of 3,120 and 4,080 ft<sup>3</sup> (8813 and 115.5 m<sup>3</sup>) for daily and monthly receipts, respectively, required to support 1,000 men for 30 days. This reconciles with allowances of 3 and 4 ft<sup>3</sup> (0.08 and 0.11 m<sup>3</sup>) per man per month contained in Refrigerated Warehouse, Category Code 431-10, of NAVFAC P-80.

## MIL-HDBK-1032/2

6.6.1 Storage Height. Design for the maximum economic storage height, using pallet racks. Floor-stacked pallets shall be stored four high (16 feet or 4880 mm).

6.6.2 Spacing of Pallets. The minimum spacing between walls and floor-stacked pallets shall be 6 inches (150 mm), and the minimum spacing between pallets shall be 4 inches (100 mm).

6.6.3 Maximum Aisle Width. Aisle width between floor-stacked pallets shall be 8 feet (2440 mm) maximum. Narrow-aisle fork lift trucks shall be used to provide the minimum possible aisle width.

6.6.4 Pallet Rack Attachment. Pallet racks shall be anchored to the floor. Attachment to, or penetration of, ceiling or wall insulation is not permitted. Provide additional rack stability by installing cross-aisle bridging to tie racks into a single structure.

6.6.5 Volume Efficiency. The greatest volume efficiency (ratio of enclosed volume to surface area) at a given height is achieved in a square structure.

## MIL-HDBK-1032/2

## Section 7: SHED STORAGE

7.1 Definition. Sheds are permanent structures without complete sides and end walls. Utilities such as water, electric, and natural gas, may be provided depending upon personnel support and fire protection requirements. Sheds are used for the storage of material that requires maximum ventilation or material that does not require complete protection from the weather. Section 7 provides additional specific criteria applicable to shed storage.

7.1.1 General Purpose Shed. Provide minimum utilities consisting of electricity for lighting and electrically operated equipment and tools. Provide fire protection in proportion to the type of material stored and the loss potential.

7.1.2 Transitory Shed. Transitory sheds are prefabricated structures which can be dismantled for movement and reassembly. They can also be positioned on concrete slabs.

7.1.3 Flammable/Hazardous Materials Shed. Bottled gases and drummed POL materials shall be stored in sheds specifically designed for such occupancies. Provide roof ventilators and ceiling sprinkler systems. Separate bottled gas storage from drummed POL storage with a 4-hour fire wall. Provide spill containment as described in subparagraph 7.3.2.

7.2 General Requirements. Design sheds for general purpose storage unless specific applications are designated in the design process.

7.2.1 Layout. Refer to NAVFAC P-272, drawings 1404519 and 1404520, for typical shed configurations. Shed layout shall be determined by function and site conditions.

7.2.1.1 Shape and Proportion. Shed shape and proportion shall be dictated by storage requirements and site conditions. Sheds for bottled gas and drummed POL storage shall not exceed a 3:1 ratio of length to width. Sheds designed for vehicle or other storage may be elongated. Length shall be limited to 600 feet (183 m).

7.2.1.2 Access. Provide access from all sides in an open POL shed or only one side in a shed designed for vehicle or construction material storage. Evaluate access requirements on the basis of function and site location.

7.2.2 Support Areas. Support functions for shed storage shall be provided by adjacent covered storage facilities. When such facilities are not available, provide office and rest room areas within the immediate shed storage area.

7.2.2.1 Supervisory Offices. Supervisory offices shall be located in existing covered storage facilities and provide the most efficient adjacency relationship with the shed storage areas, employee service and operating areas, parking, and utilities.

## MIL-HDBK-1032/2

7.2.2.2 Employee Service Areas. Size and extent of rest room and locker facilities provided to shed storage personnel depend on the number of employees required and on the adjacency relationship to the other support systems. In cold or wet climates, provide a heated warm-up room for shelter.

7.2.2.3 Other Support Areas. The need for inspection, classification, crating, packing, and repair areas shall be evaluated. If appropriate, these areas, as well as other support areas, may be provided adjacent to similar facilities for covered storage.

7.2.3 Storage Areas. Sheds may be divided into multiple storage areas to provide material segregation or improved security.

7.2.4 Storage Surface. Both improved and semi-improved shed storage surfaces shall be graded and finished to provide controlled drainage and a durable storage surface.

7.2.4.1 Improved. Improved surfaces are impervious and therefore demand careful attention to slope and drainage requirements.

a) Portland Cement Concrete. Concrete surfaces provide the strongest base of support for heavy materials and shall be reinforced. Concrete may also be used where heavy traffic volumes are anticipated or where an impervious surface is required and asphaltic concrete is inappropriate due to susceptibility to petroleum spills.

b) Asphaltic Concrete. Asphaltic concrete surfaces may be used where a durable impervious surface is desired, but the strength provided by portland cement concrete is not required.

7.2.4.2 Semi-Improved. Unpaved surfaces are not recommended for shed storage functions unless the structure is designated as temporary and permanent surface improvements are not justified.

7.2.5 Drainage. Provide drainage for the shed and adjacent open areas to maintain the structural integrity of the storage surfaces and prevent flooding of the structure during and after inclement weather.

7.2.6 Utilities. Provide water and electric utilities, as required, for fire protection and lighting purposes.

7.2.6.1 Water, Plumbing, and Sanitary Sewer. Water may be required for maintenance cleaning of stored material and equipment upon receipt or shipment, and also for cleaning of storage/handling equipment. In cases where water used for cleaning may become contaminated with petroleum products, the water shall be contained and treated as required for wash facilities. For detailed design criteria, refer to Water Supply Systems, NAVFAC DM-5.07; Domestic Wastewater Control, NAVFAC DM-5.08; and DOD 4270.1-M.

## MIL-HDBK-1032/2

7.2.6.2 Electrical. Electrical system design shall be in accordance with the NAVFAC Electrical Engineering Criteria Manuals and NFPA 70. Requirements for shed support areas are similar to covered storage requirements. Electrical power may be required in shed storage areas for power tool operation involved with crating, packing, or any special operation required by storage/handling of certain materials and equipment.

7.2.6.3 Communications. Intercoms, remote call boxes, or telephones shall be evaluated for cost-effectiveness based on the size, location, and layout of the facility.

7.2.7 Security. Where stored materials or equipment require security due to the open construction of sheds, provide the following:

7.2.7.1 Fencing. Provide security fencing in conformance with the activity security policy and as required by Fencing, Gates, and Guard Towers, NAVFAC DM-5.12.

7.2.7.2 Surveillance. Surveillance of the entire fenced perimeter must be possible.

7.2.7.3 Lighting. Provide illumination of 0.5-1.0 footcandles (5-10 lux) in open areas around sheds. Where necessary for security reasons, increase lighting intensity to meet security requirements of the activity.

7.2.8 Preservation Measures. The semi-open or open nature of sheds requires attention to preservation measures for materials stored in shed storage areas. Evaluate design elements of shed layout with regard to sun, prevailing wind direction, and wind-blown snow or rain.

7.2.8.1 Direct Exposure. Avoiding direct exposure to the following physical agents is a function of shed design and orientation.

- a) Sun
- b) Precipitation
- c) Wind driven sand
- d) Wind driven snow

7.2.8.2 Corrosive Environment, Humidity, and Temperature Extremes. Materials and equipment sensitive to these problems require protective coating treatment and periodic inspection.

### 7.3 Bottled Gas and Drummed POL Storage.

7.3.1 Layout. Storage of bottled gas and drummed POL may be performed in sheds either separated from or contiguous with covered storage or flammable or hazardous materials warehouses. Provide fire walls and fire doors to separate bottled gases from drummed POL.

MIL-HDBK-1032/2

7.3.2 Drainage/Containment. Provide containment systems for spills outside of sheds designed for storage of drummed POL. Containment systems shall provide access across berms or curbing for materials handling equipment and fire protection apparatus and shall be capable of containing the maximum potential volume of spillage or 10 percent of the volume of liquid stored. Refer to 29CFR, 1910.106, for additional guidance.

7.3.3 Sprinklers. Equip sheds with ceiling sprinklers providing a density equivalent to that required for similar materials in a covered storage warehouse. All doors leading to contiguous buildings shall be equipped with flow intercepting drains or berms.

7.3.4 Fire Walls/Fire Doors. Separate sheds from contiguous hazardous materials warehouses by a 4-hour rated blank fire wall. Sheds storing both bottled gases and drummed POL materials shall separate the two materials with a 4-hour rated blank fire wall. The fire wall shall project above the roof a minimum of 3 feet (915 mm). Openings through fire walls shall be protected on both sides by 3-hour rated fire doors.

7.3.5 Ventilation. Provide roof and eave mounted nonpowered ventilation devices to reduce heat build-up.

## MIL-HDBK-1032/2

## Section 8: CONTROLLED HUMIDITY WAREHOUSING

8.1 Dehumidification. Warehouses designed for dehumidified storage shall be vapor sealed against entrance of moisture from points of higher vapor pressure. Refer to NAVFAC DM-3.03 for additional design criteria. A dry desiccant-type dehumidifier shall be used. The preferred unit is a steam-fired type with two stationary beds operating alternately on the drying and regeneration cycles. Rotary-type units may also be used. If steam is not available, electric or gas-fired units may be used. A study evaluating the energy efficiency of the desiccant system compared to a refrigerated dehumidification system shall be made. Section 8 provides additional specific criteria applicable to controlled humidity storage.

8.2 Carbon Monoxide Control. Supply outside air ventilation if gasoline-driven materials handling equipment is operated in a dehumidified warehouse and the average concentration of carbon monoxide in the space will exceed 50 parts per 1,000,000 parts of air. Provide portable carbon monoxide detection equipment to periodically check for carbon monoxide concentrations in facilities with gasoline powered equipment. Ventilation may be obtained by opening operable material transfer doors. Provide a 20-ampere electric power outlet receptacle at each operable transfer door to operate a portable circulating fan when natural ventilation is inadequate. Use of battery operated vehicles is recommended where practical.

8.3 New Construction. For new construction, the following sealing methods and materials shall be used.:

8.3.1 Floors. Vapor barriers having a permeance characteristic of 1.0 perm or less, laid on a gravel capillary barrier and finished to a smooth surface, shall be provided beneath concrete slabs laid on-grade.

8.3.2 Walls. Insulation shall not be provided for walls. Apply two coats of cement water paint to exterior exposed surfaces of concrete masonry unit walls. Sprayed-on cement mortar coating 1/8 inch (3mm) in total thickness may be used as an alternative method.

8.3.2.1 Joints. All joints in precast concrete construction shall be sealed, caulked, and made as airtight as possible.

8.3.2.2 Sides and End Laps. All sides and end laps of metal or similar type walls shall be sealed with bituminous mastic as erected.

8.3.2.3 Fire Walls. If only certain areas are to be dehumidified, the fire wall between the dehumidified and general storage areas shall be made airtight.

8.3.2.4 Junctions. Exterior junctions between walls and roofs shall be made as airtight as possible.

8.3.3 Roof. Vapor barriers shall be provided. All sides and end laps in steel or similar roof decking shall be coated with bituminous mastic as laid. Scuttles shall be gasketed and fitted with inside and outside locks.



## MIL-HDBK-1032/2

8.3.4 Doors. Active cargo doors shall be gasketed by means of extruded, non-ferrous weatherstrips housing sponge rubber seals. One door to each exterior side wall of each compartment shall be motor operated. The other doors shall be chain hoist operated, from the inside only, with provision for future motor operation. Active cargo doors at end walls shall be similarly gasketed and chain hoist operated.

8.3.4.1 Personnel Doors. Provide two 3-foot (915 mm) by 6-foot 8-inch (2030 mm) personnel doors, hinged and gasketed, located near motor operated doors.

8.3.4.2 Fire Doors. Fire doors between dehumidified and nondehumidified areas shall be gasketed and made as airtight as possible.

8.4 Conversion of Existing Structures to Dehumidified Storage. Apply requirements for new construction to existing walls and roofs. To convert structures, accomplish the following:

8.4.1 Ventilators. Remove roof ventilators. Cover openings and patch roofing.

8.4.2 Openings. Seal all louvered openings and windows in walls.

8.4.3 New Doors. Ensure that all new doors (required to replace existing doors) conform to new construction requirements.

8.4.4 Active Doors. Existing cargo doors that are to remain active shall be gasketed and shall otherwise conform to requirements for new construction. Provide sliding doors with CAM action hangars to allow them to be drawn up tight against gaskets when closed.

8.4.5 Excess Doors. Deactivate and seal excess cargo doors.

## MIL-HDBK-1032/2

## Section 9: MODERNIZATION OF EXISTING GENERAL WAREHOUSE BUILDINGS

9.1 Purpose. It is the intent to bring the existing semi-permanent and permanent warehouse buildings to a level comparable with current standards for new construction, in accordance with criteria in the appropriate Design Manuals. Buildings selected for modernization shall be architecturally acceptable and structurally sound. Existing low-rise buildings can be used for support functions when located adjacent to new high-rise facilities. Section 9 provides additional specific criteria applicable to modernization of facilities.

9.2 Architectural Requirements. General architectural requirements include the following:

9.2.1 Floors. Install resilient floor tiles, with appropriate base, in administration offices where the present floor surface is concrete. If the present floor is wood, tiles, or linoleum, provide new tile only if the existing floor is excessively worn and unattractive. Repair concrete floors in storage areas if the surface is in poor condition.

9.2.2 Interior Finishes. The painting of some spaces may be in an unacceptable condition or of colors contrary to those prescribed by criteria or according to use or occupancy. Such spaces shall be repainted in colors complying with the NAVFAC Architecture Criteria Manuals and NAVFAC P-309.

9.2.3 Design For Handicapped. Perform modifications necessary to assure access to the handicapped unless building use is specifically restricted to able-bodied military personnel. Modifications shall be in accordance with criteria in the NAVFAC Architecture Criteria Manuals, DOD 4270.1-M, and ANSI A117.1-1961 (R1980).

9.2.4 Roof. Inspect roofing and flashing for deterioration, cracks, and wind damage. Repair or replace deteriorated, damaged, or missing flashing and roofing. Install or increase insulation in accordance with requirements of NAVFAC DM-3.03.

9.2.5 Doors And Windows. Inspect doors and windows. Replace broken glass and repair or replace weatherstripping. If doors or windows are severely deteriorated, investigate the economics of replacement with energy efficient models.

9.3 Structural Requirements. When it is determined that the structural system will not satisfy the design loads, those members which are considered inadequate shall be strengthened, modified, or replaced.

9.3.1 Structural Systems. Structural systems should be inspected and, where deficiencies are noted, the following shall be performed:

9.3.1.1 Steel Members. Clean off any corrosion and apply rust-resistant paint.

## MIL-HDBK-1032/2

9.3.1.2 Concrete Members. Fill cracks with filler and patch any spalling areas.

9.3.1.3 Wood Members. Tighten all bolts, screws, and other fasteners. Where necessary, impregnate timber with antimildew and antitermite solutions.

9.3.2 Modifications. Where modifications are made to improve functional operations, the structural system may be modified, providing that the new load distribution created by such modifications does not overload existing members.

9.4 Plumbing Requirements. For plumbing requirements, refer to NAVFAC DM-3.01. Reuse acceptable fixtures.

9.5 Electrical Requirements. For electrical requirements, refer to the NAVFAC Electrical Engineering Criteria Manuals. All undisturbed wiring and the equipment judged to be in safe, operable condition shall be reused.

9.6 Mechanical Requirements. For mechanical requirements, refer to NAVFAC DM-3.01. Reuse acceptable fixtures and equipment.

9.7 Fire Protection. For fire protection requirements, refer to MIL-HDBK-1008.

9.8 Asbestos. Asbestos based floor tile, building insulation, or mechanical equipment insulation shall not be used in Navy facilities. Removal and disposal of existing asbestos containing material shall be in accordance with criteria of Environmental Protection Agency, OSHA, and Removal and Disposal of Asbestos Materials, NFGS-02075.

## MIL-HDBK-1032/2

## APPENDIX A

## ILLUSTRATIONS OF TYPICAL COLD STORAGE CONSTRUCTION AND INSULATION

The Figures in Appendix A illustrate typical methods and means for the construction and insulation of Cold Storage Facilities. These illustrations shall be used in conjunction with the comments in Section 6 regarding cold storage facility criteria as well as NAVFAC P-272 Definitive Drawing 1404208 which illustrates typical facility configurations. Although built-up roofing is indicated, single-ply Ethylene Propylene Diene Monomer may be used, if applicable.

## --- Abbreviations Used On Drawings ---

|      |                         |       |               |
|------|-------------------------|-------|---------------|
| CMU  | - Concrete masonry unit | FL    | - Floor       |
| COL  | - Column                | INSUL | - Insulation  |
| CONC | - Concrete              | OC    | - On center   |
| FIP  | - Foam-in-place         | TEMP  | - Temperature |
| FIN  | - Finished              | WD    | - Wood        |

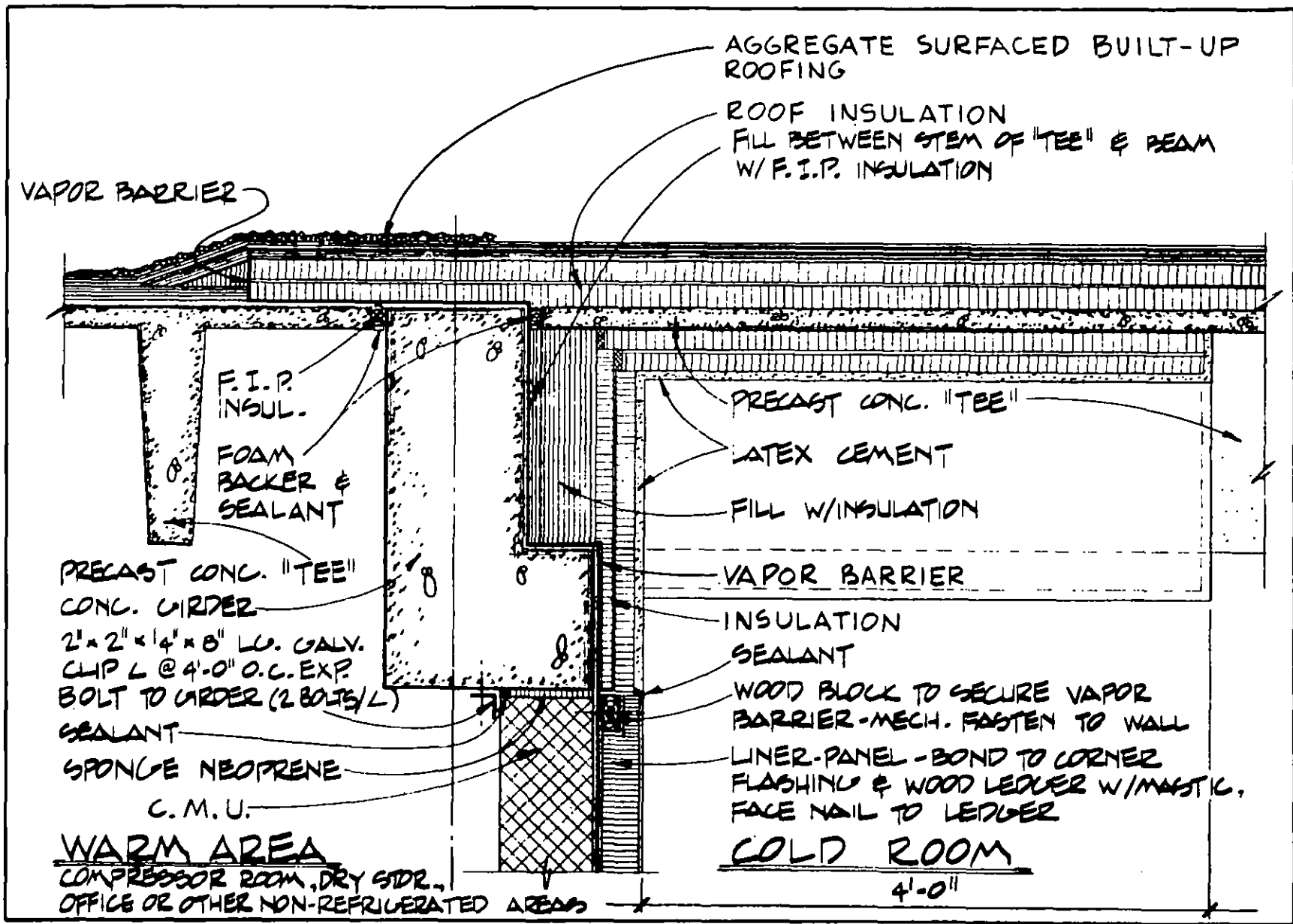

Figure A-1

Cold Room Insulation Detail 1

101

MIL-HDBK-1032/2

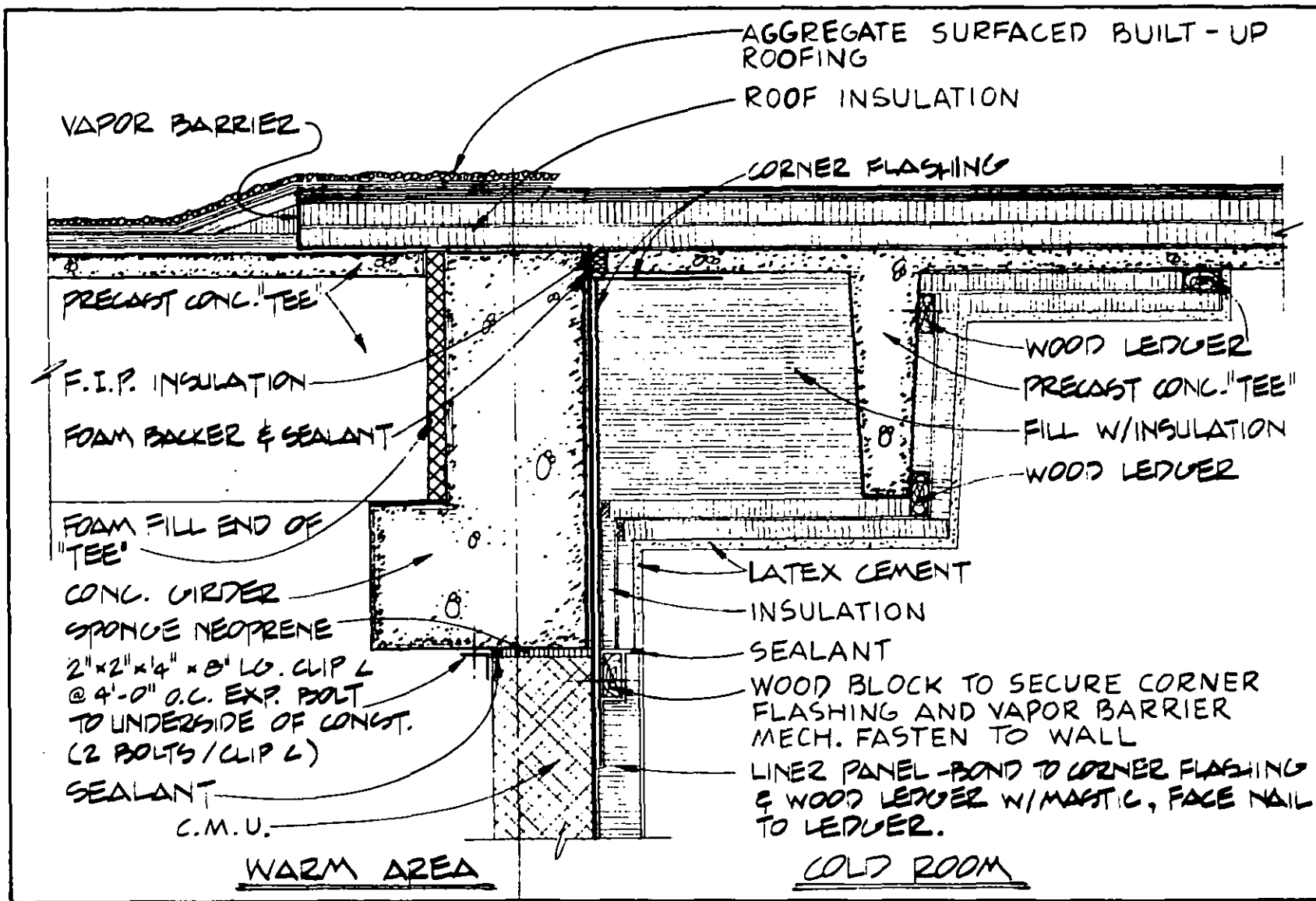
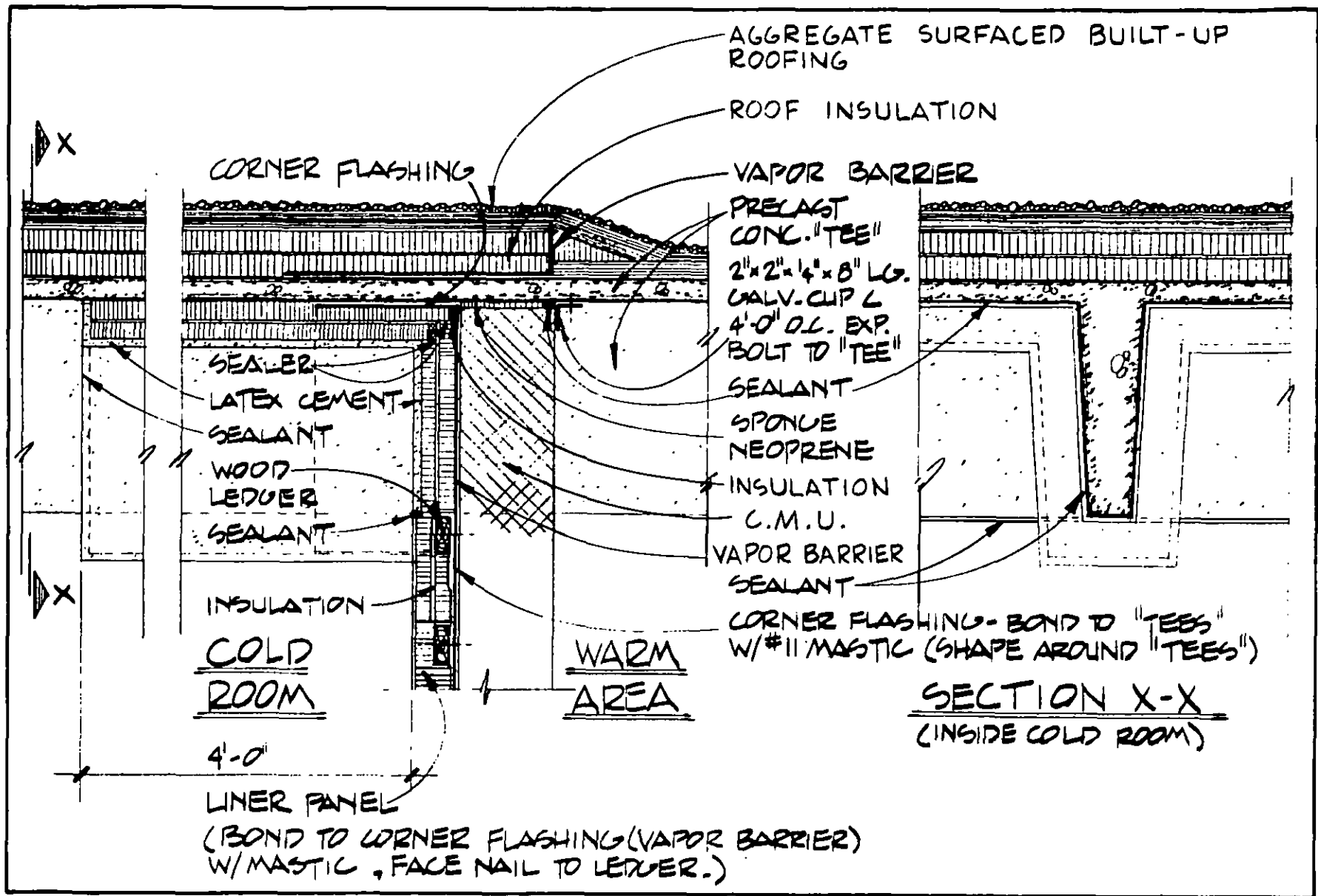

Figure A-2

Cold Room Insulation Detail 2

102



MIL-HDBK-1032/2

Figure A-3

Cold Room Insulation Detail 3

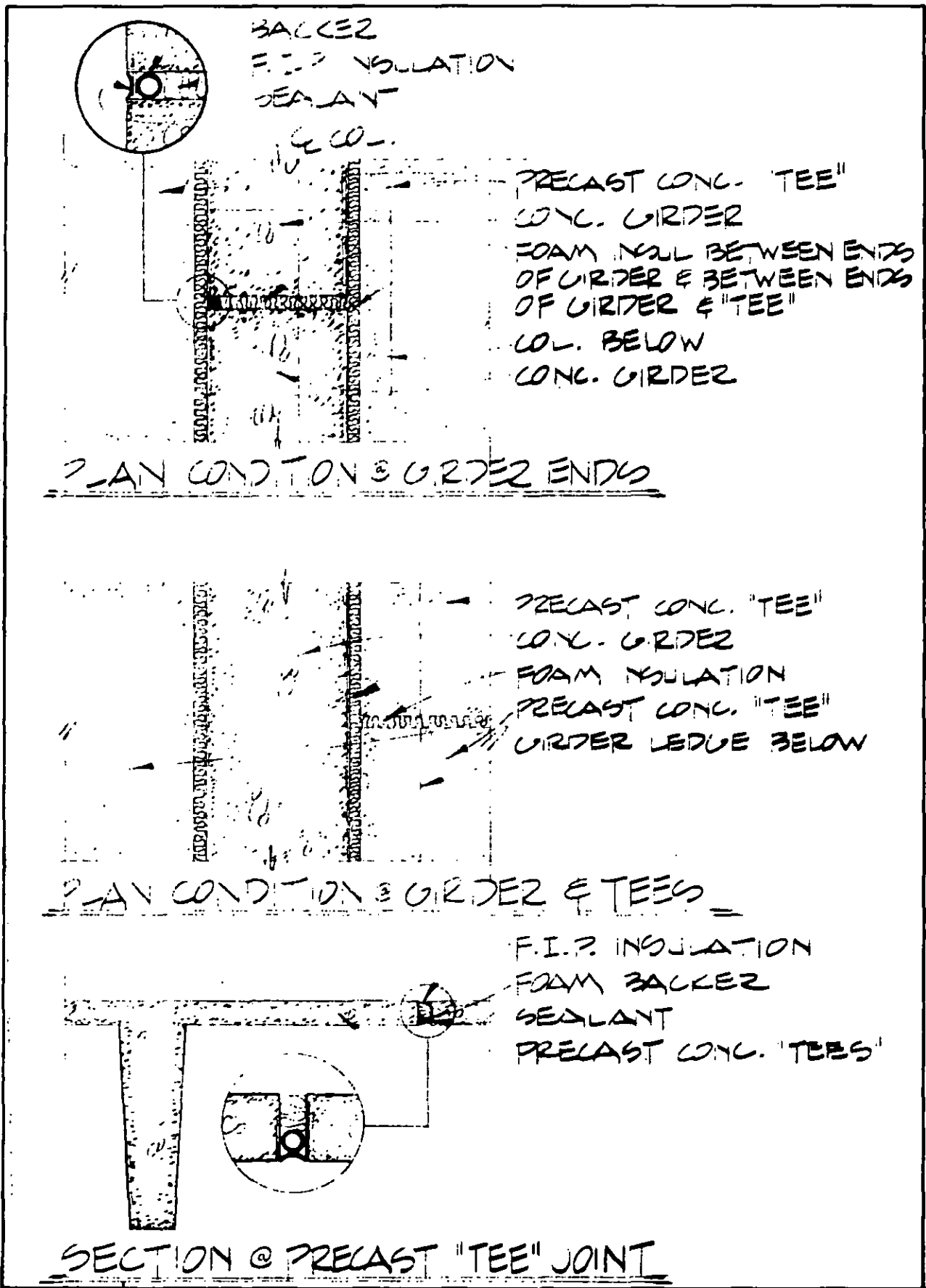
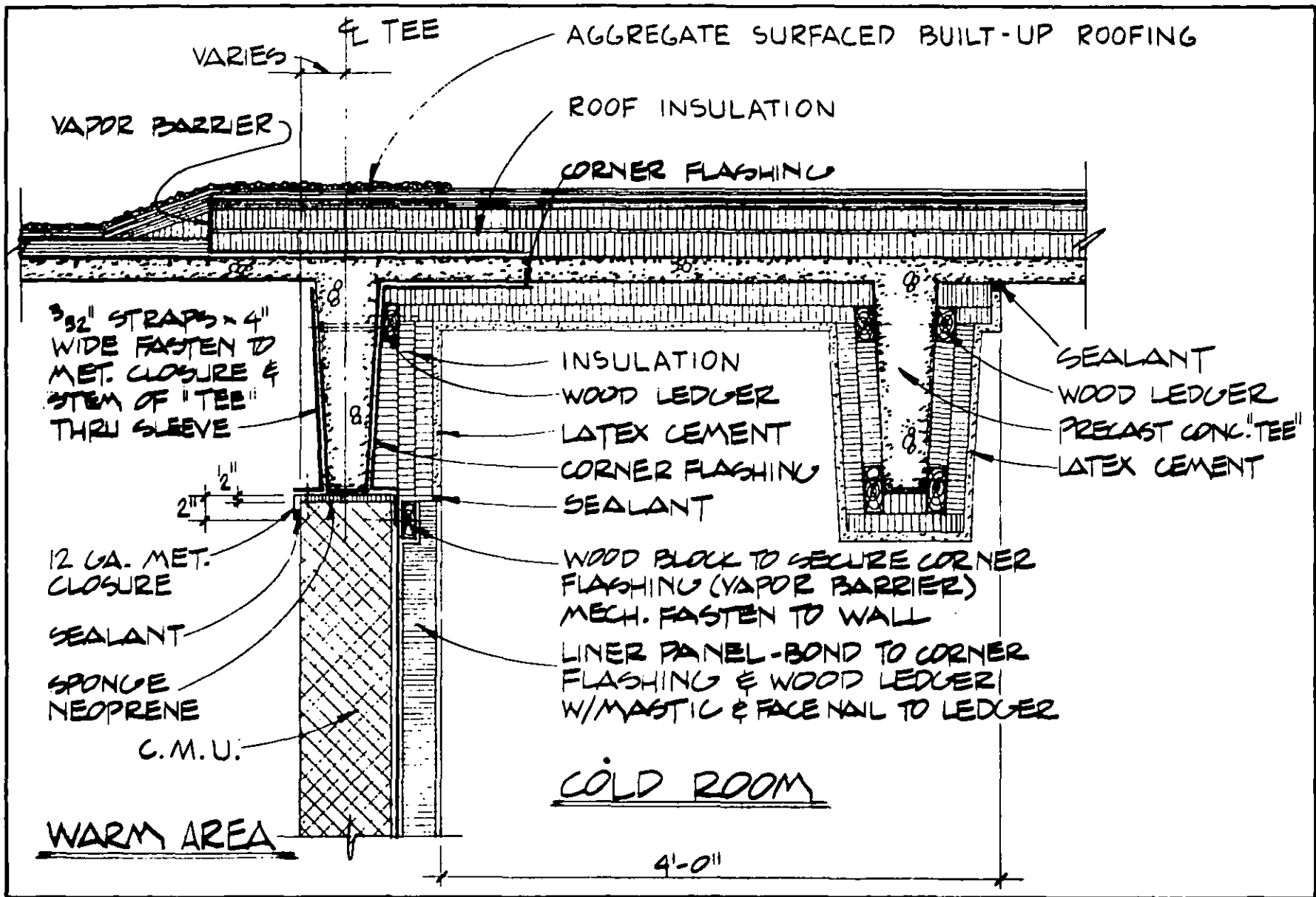

Figure A-4  
Cold Room Insulation Detail 4





104

MIL-HDBK-1032/2

Figure A-5

Cold Room Insulation Detail 5

105

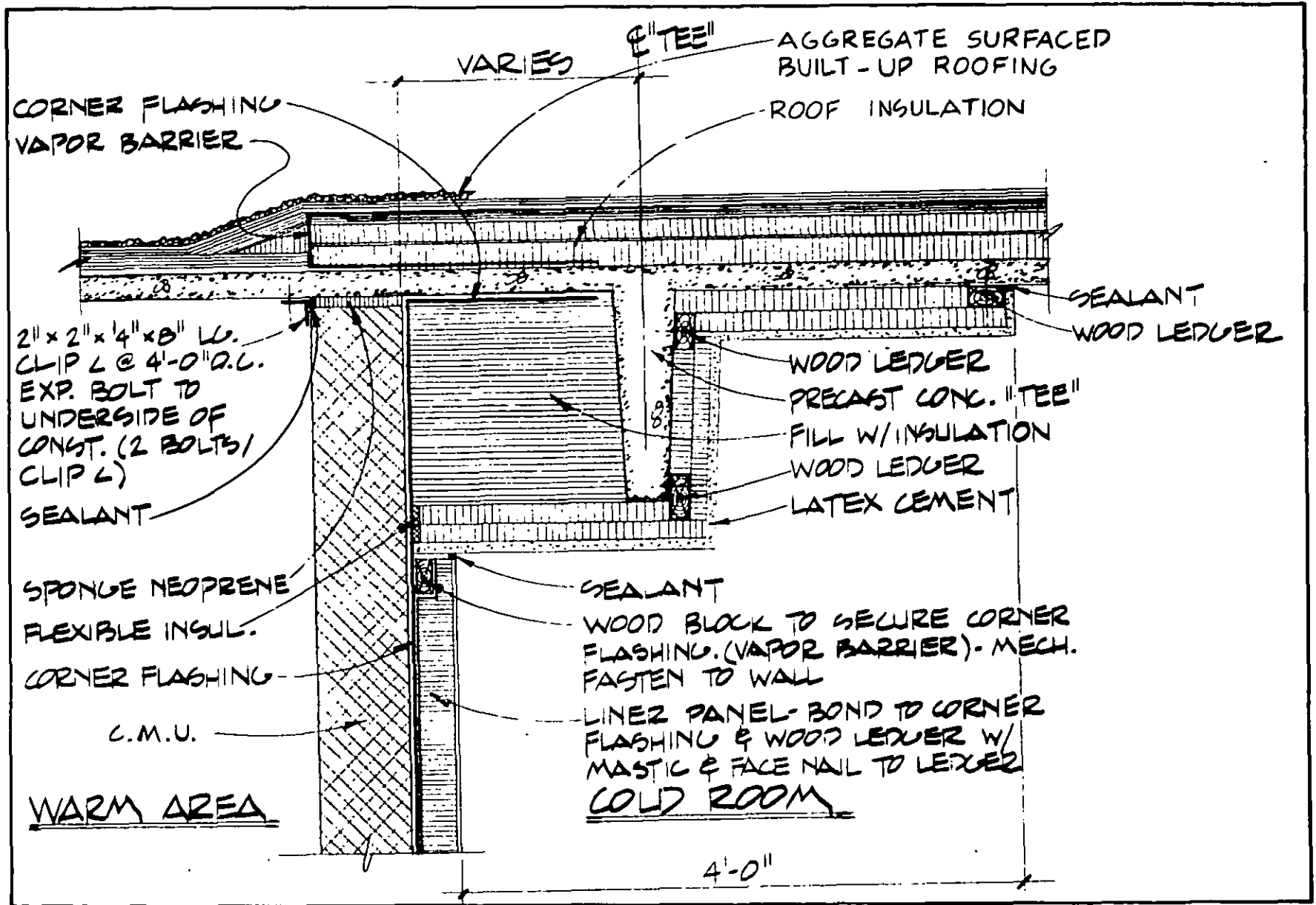

MIL-HDBK-1032/2

Figure A-6

Cold Room Insulation Detail 6

106

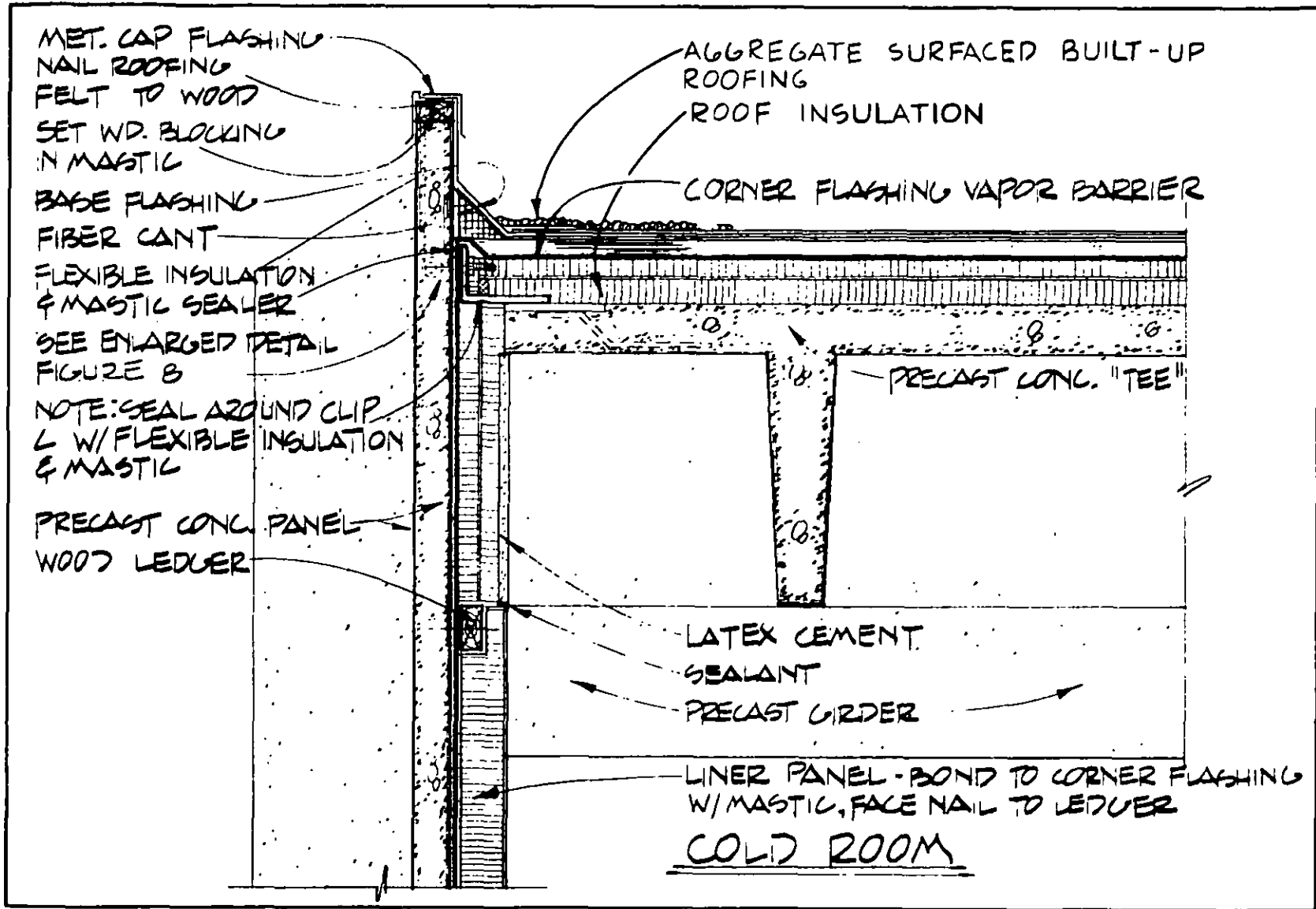

MIL-HDBK-1032/2

Figure A-7

Cold Room Insulation Detail 7

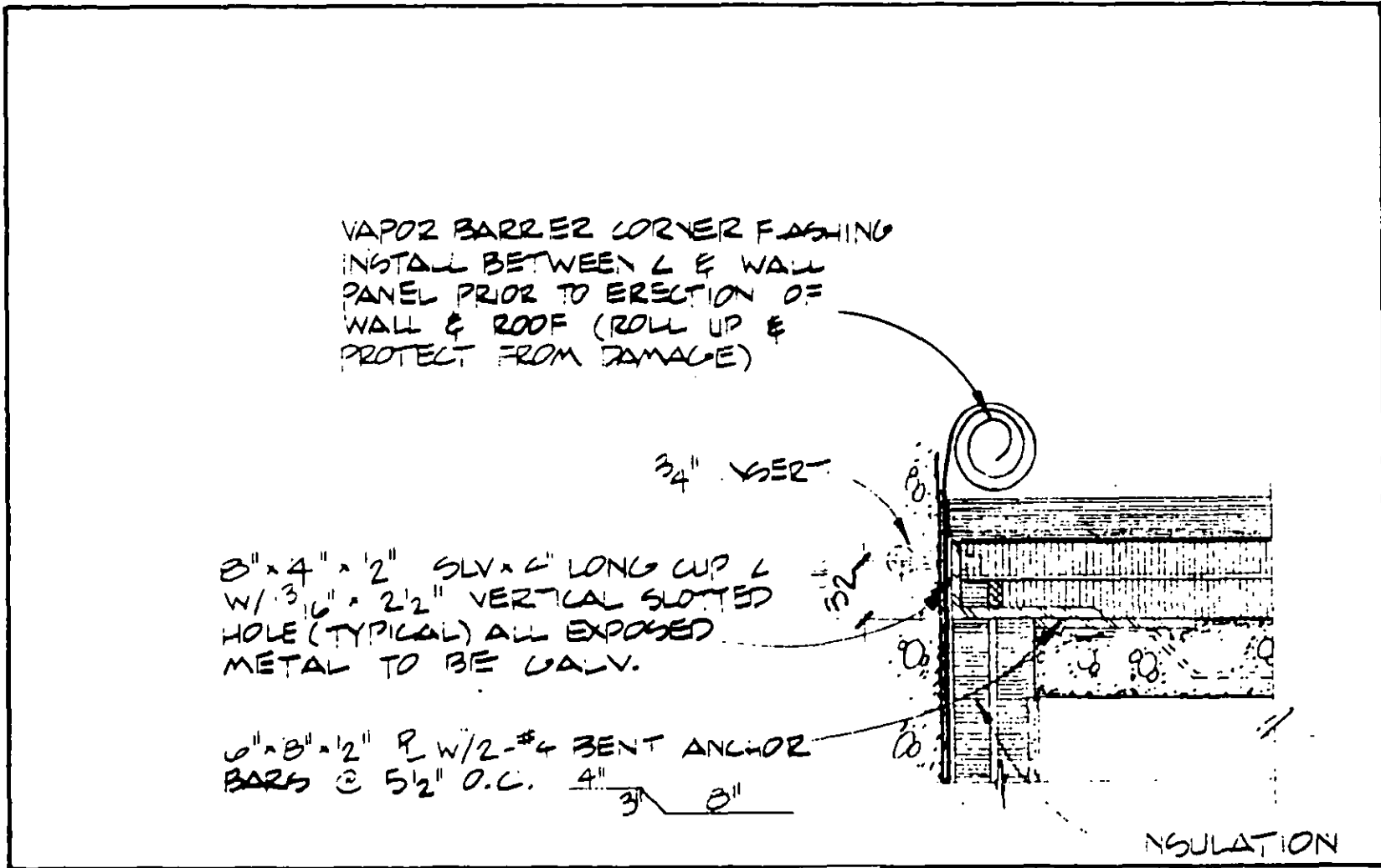
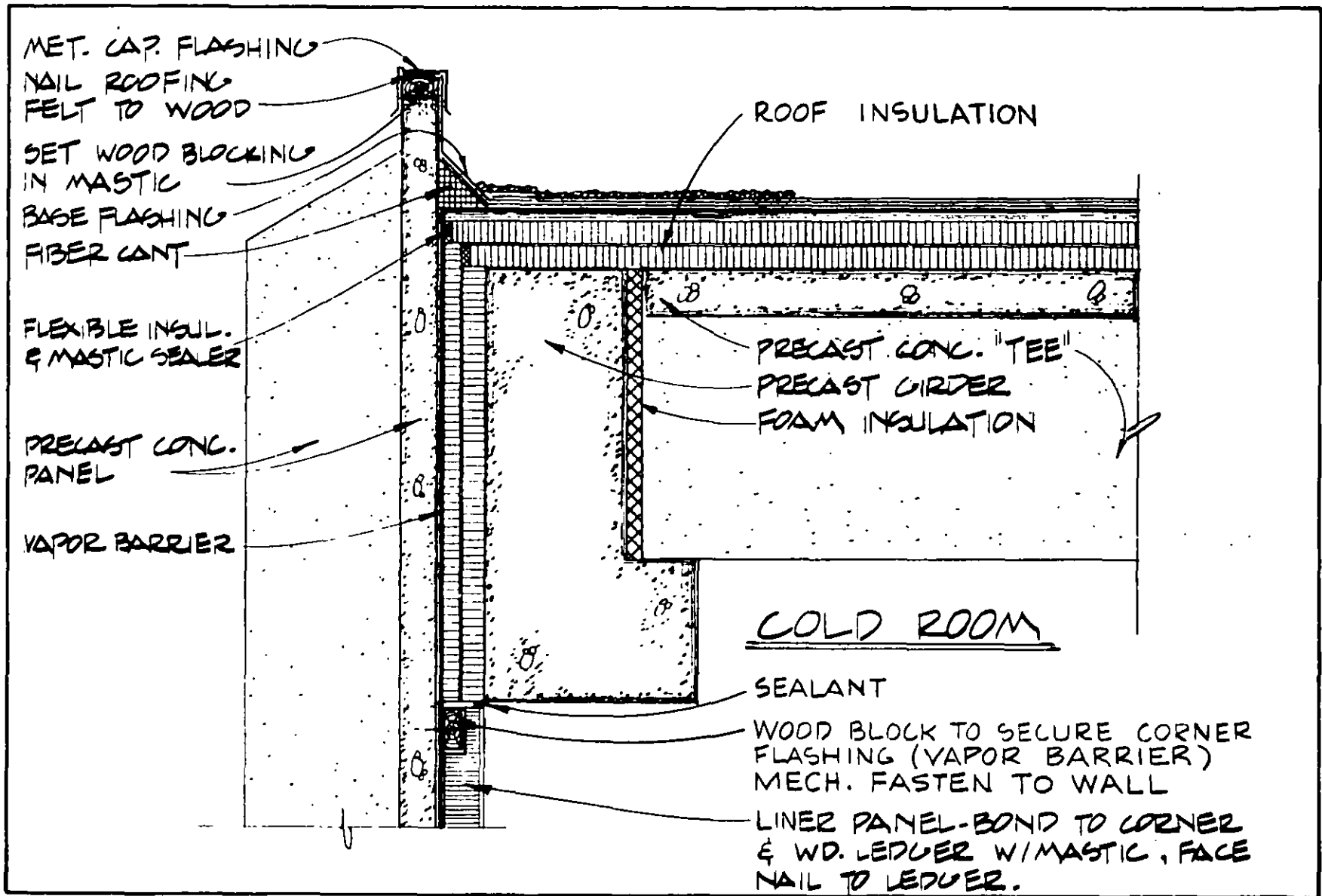

Figure A-8

Enlarged Cold Room Insulation Detail



108

MIL-HDBK-1032/2

Figure A-9

Cold Room Insulation Detail 8

MIL-HDBK-1032/2

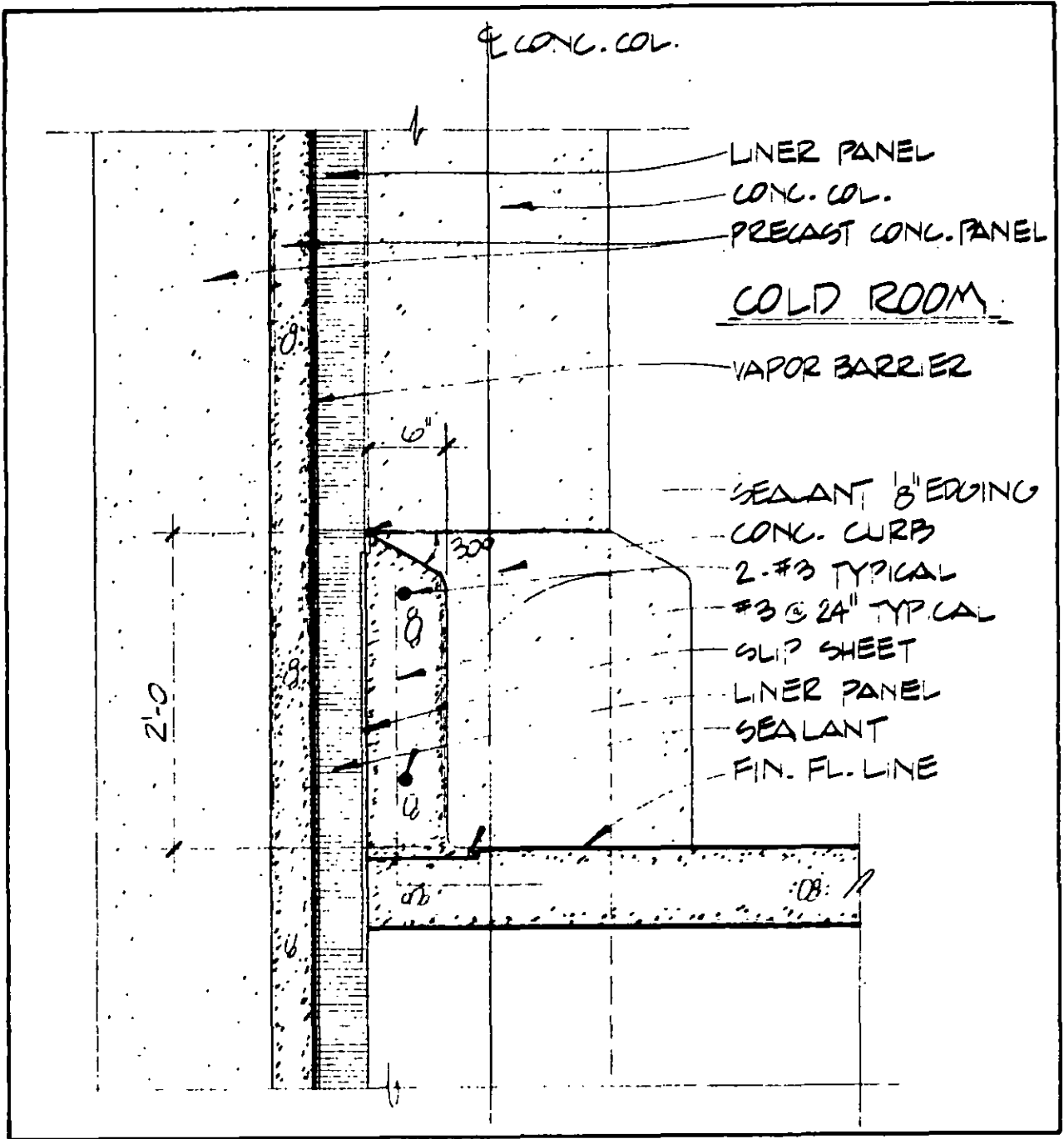

Figure A-10

Cold Room Insulation Detail 9

MIL-HDBK-1032/2

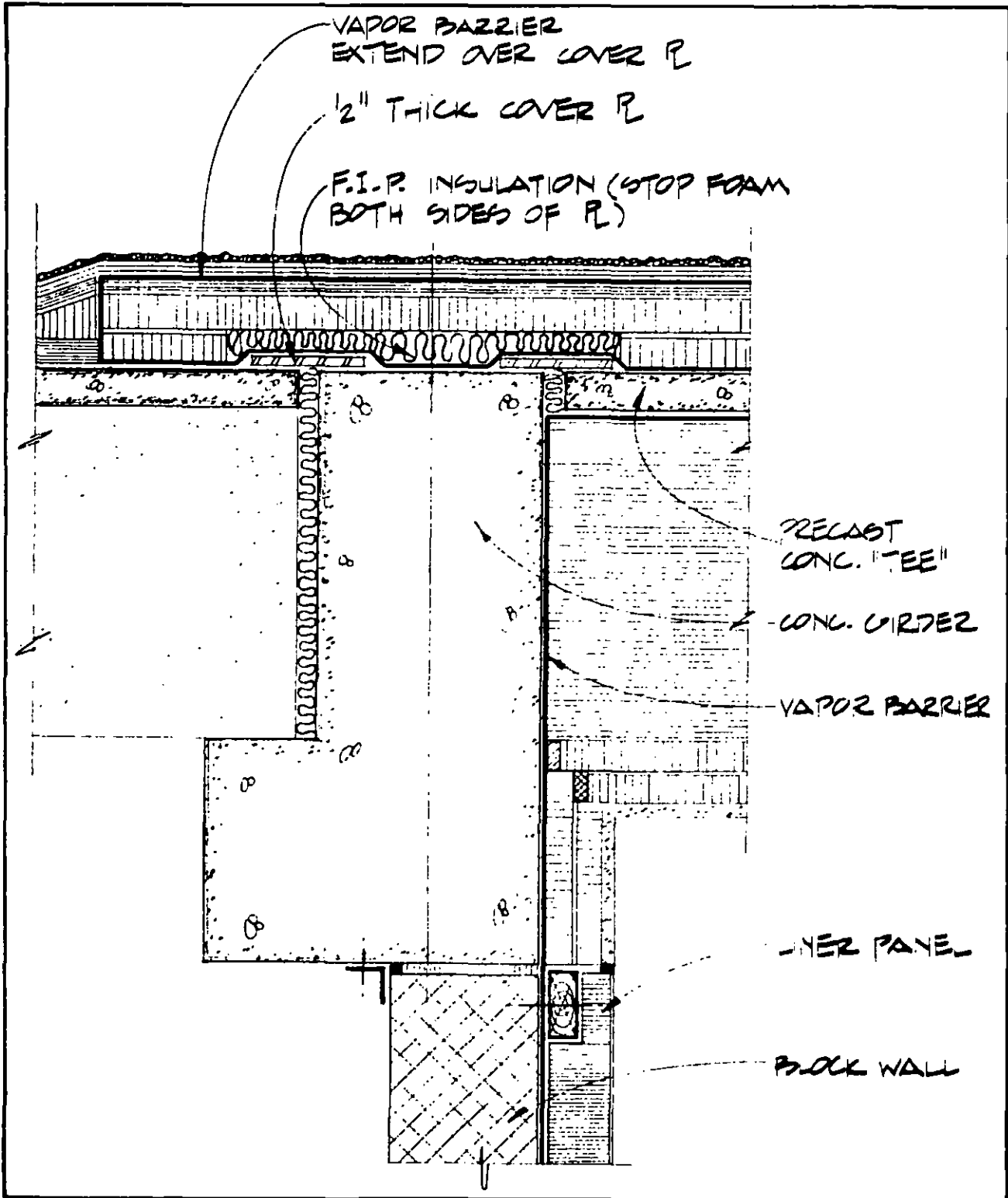
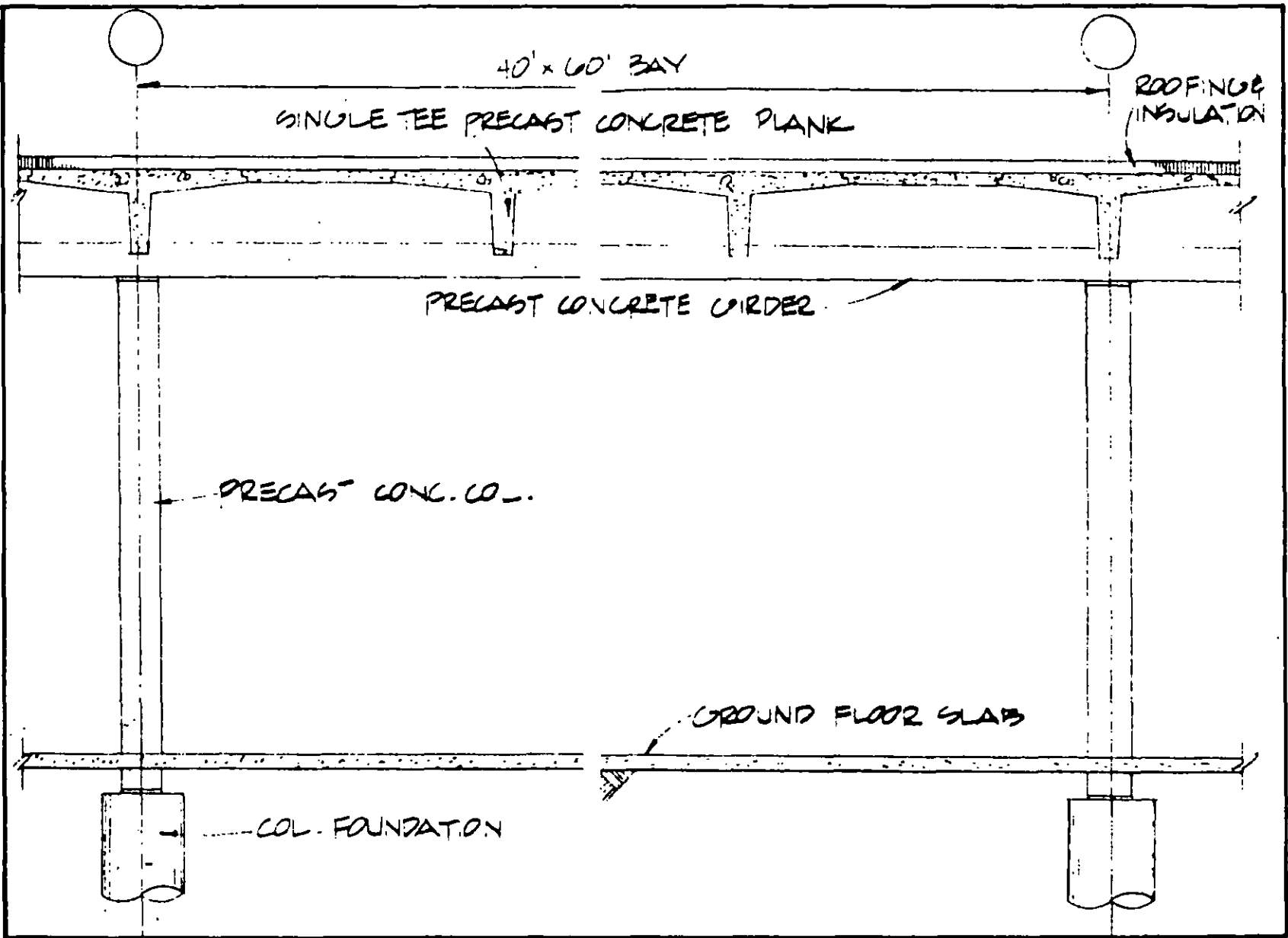

Figure A-11

Cold Room Insulation Detail 10



111

MIL-HDBK-1032/2

Figure A-12

Precast Concrete Single Tee Construction



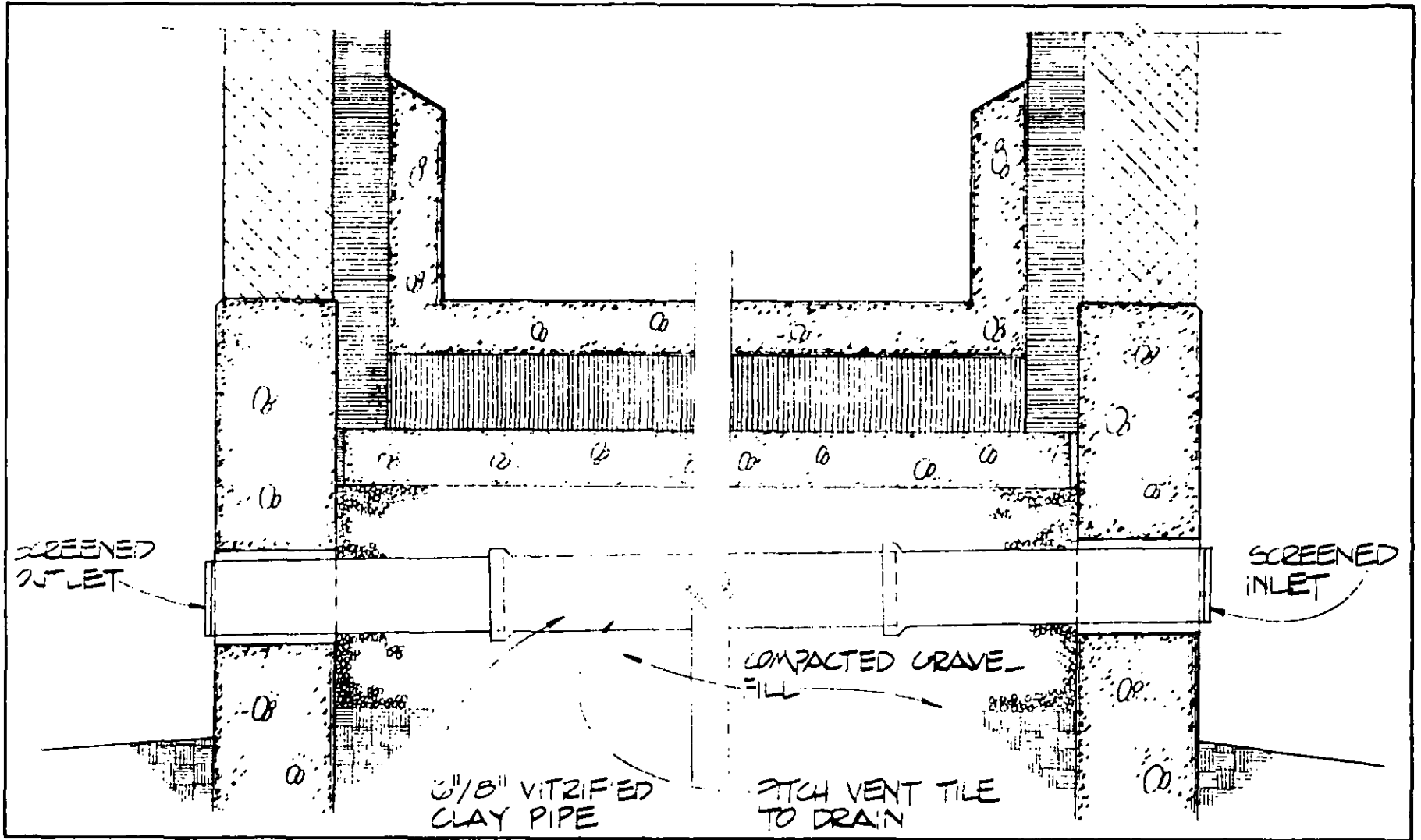

Figure A-13  
Typical Underfloor Air Duct Heat System For Slab On Ground Freezers

MIL-HDBK-1032/2

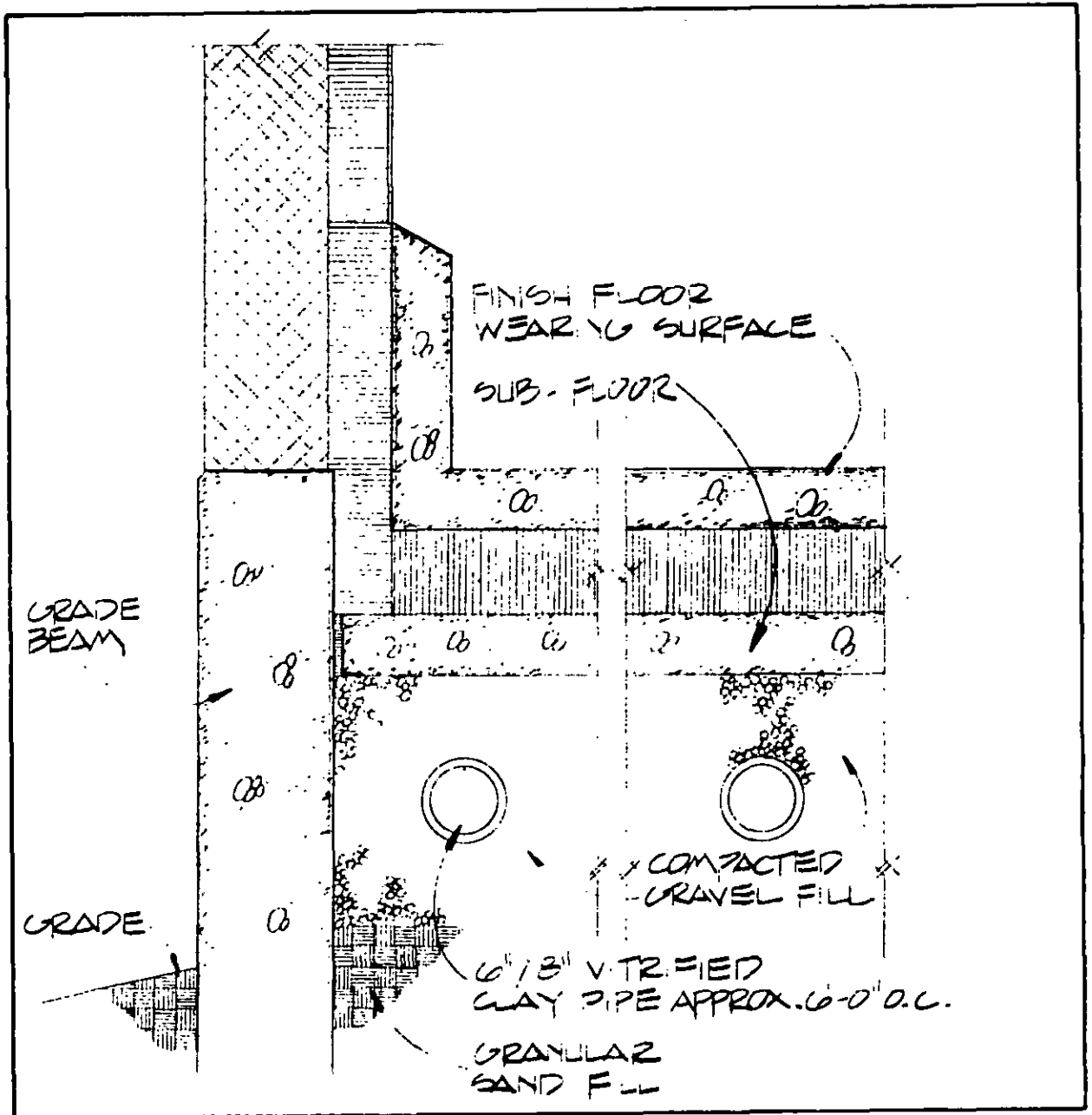

Figure A-14

Typical Underfloor Air Duct Heat System

MIL-HDBK-1032/2

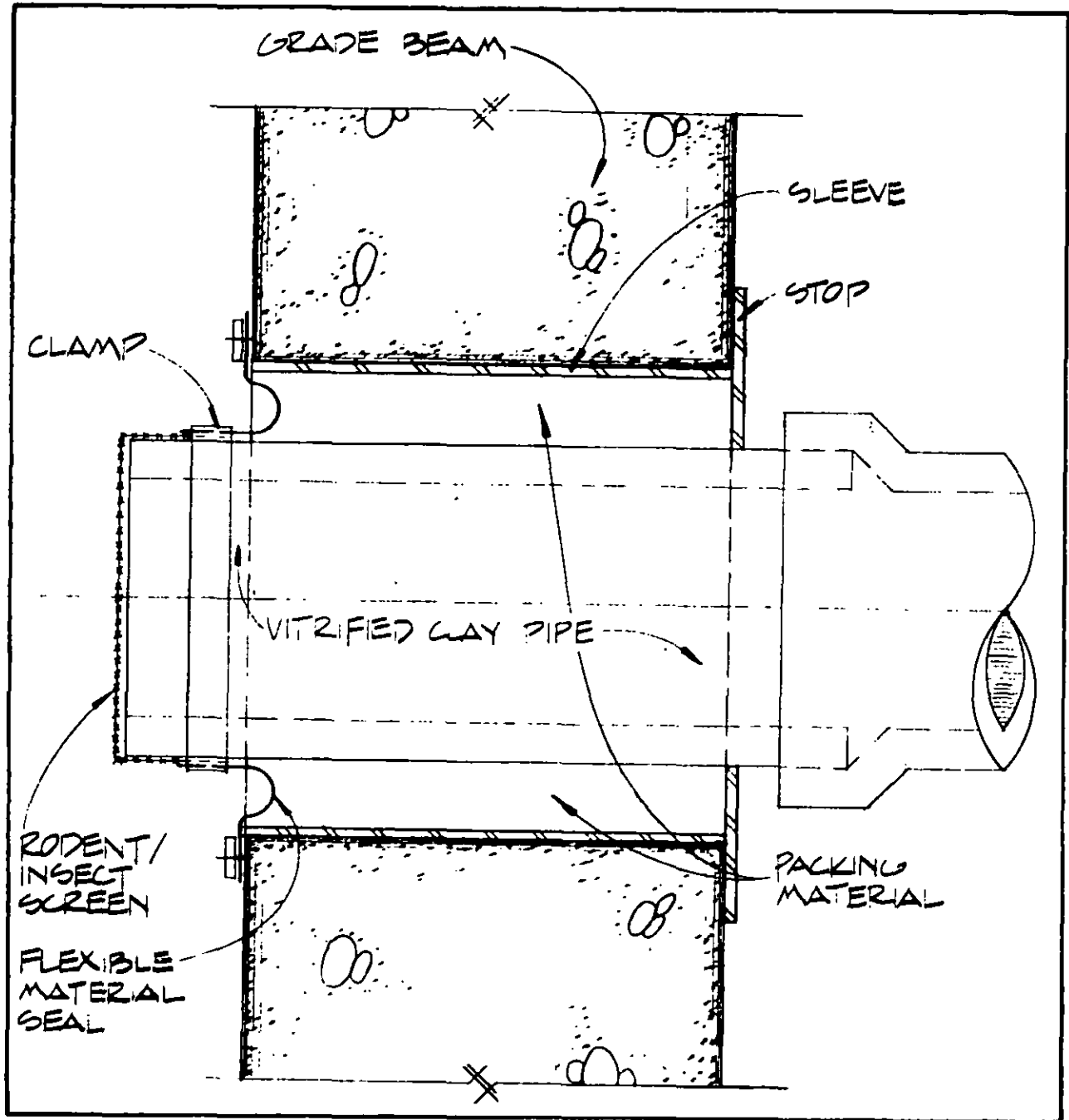

Figure A-15

Underfloor Air Duct Heat System  
Thru Wall Detail

MIL-HDBK-1032/2

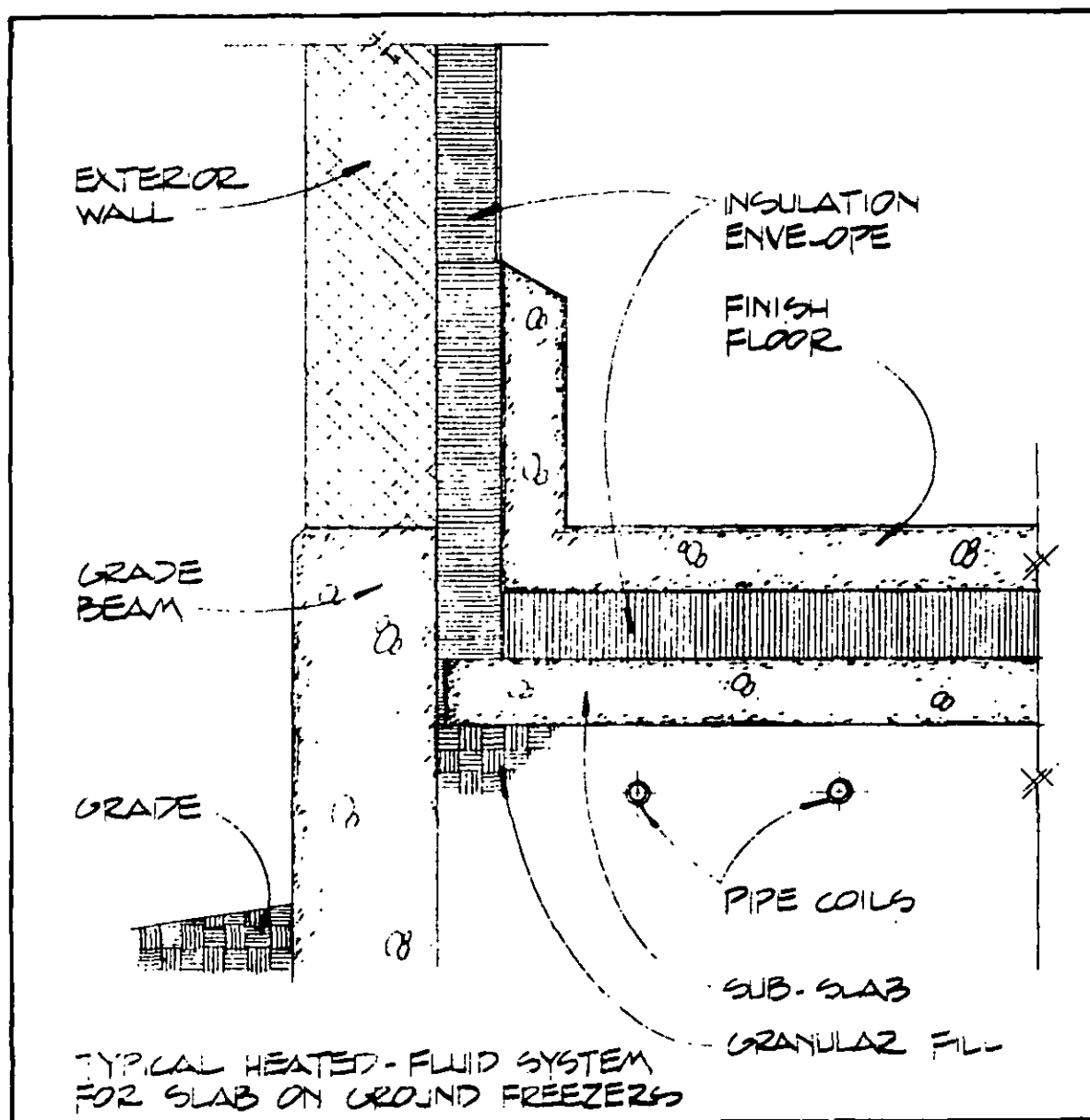

Figure A-16

Underfloor Warming System Detail

MIL-HDBK-1032/2

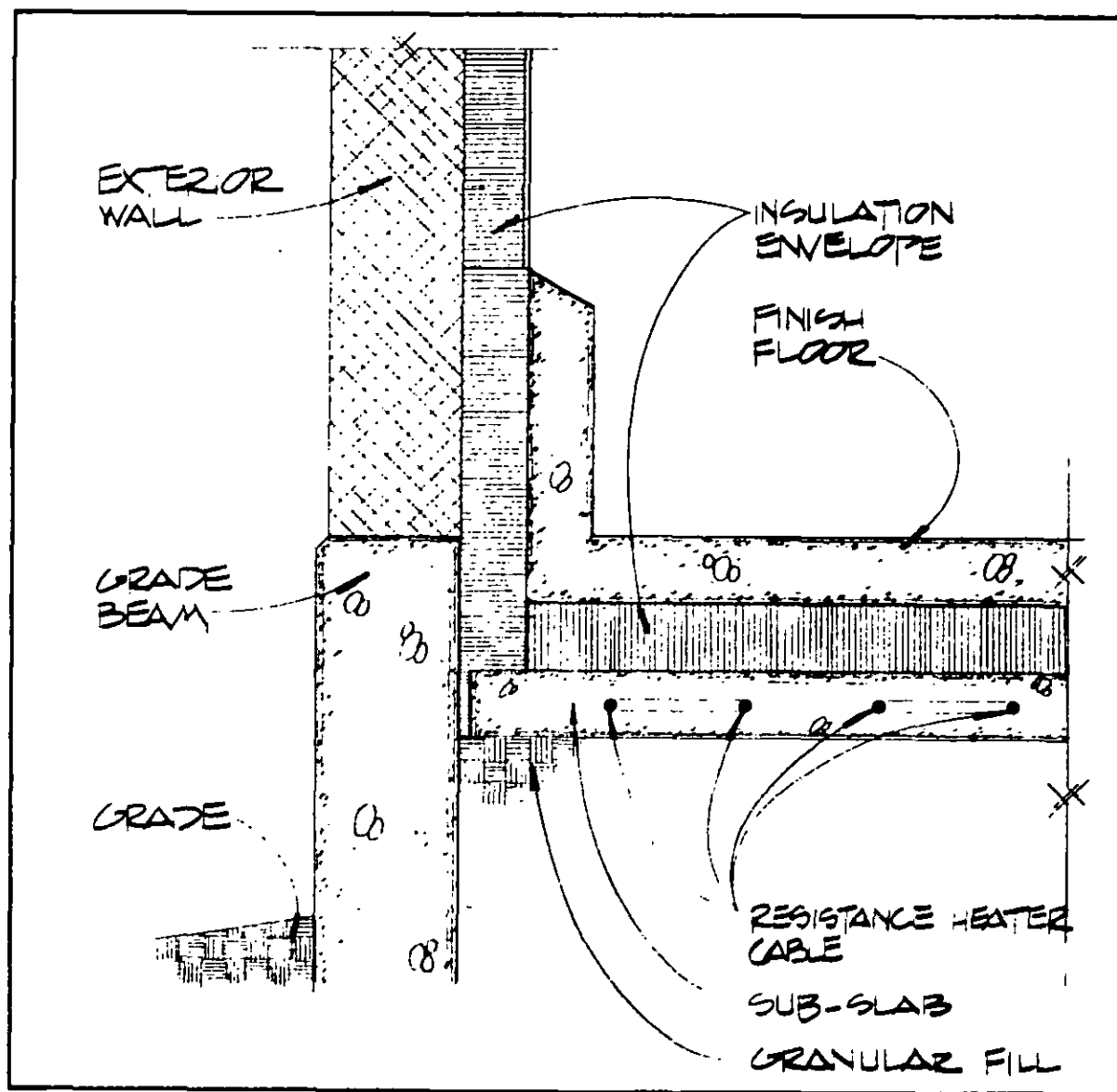

Figure A-17

Typical Electric-Resistance Heating System  
For Slab On Ground Freezers

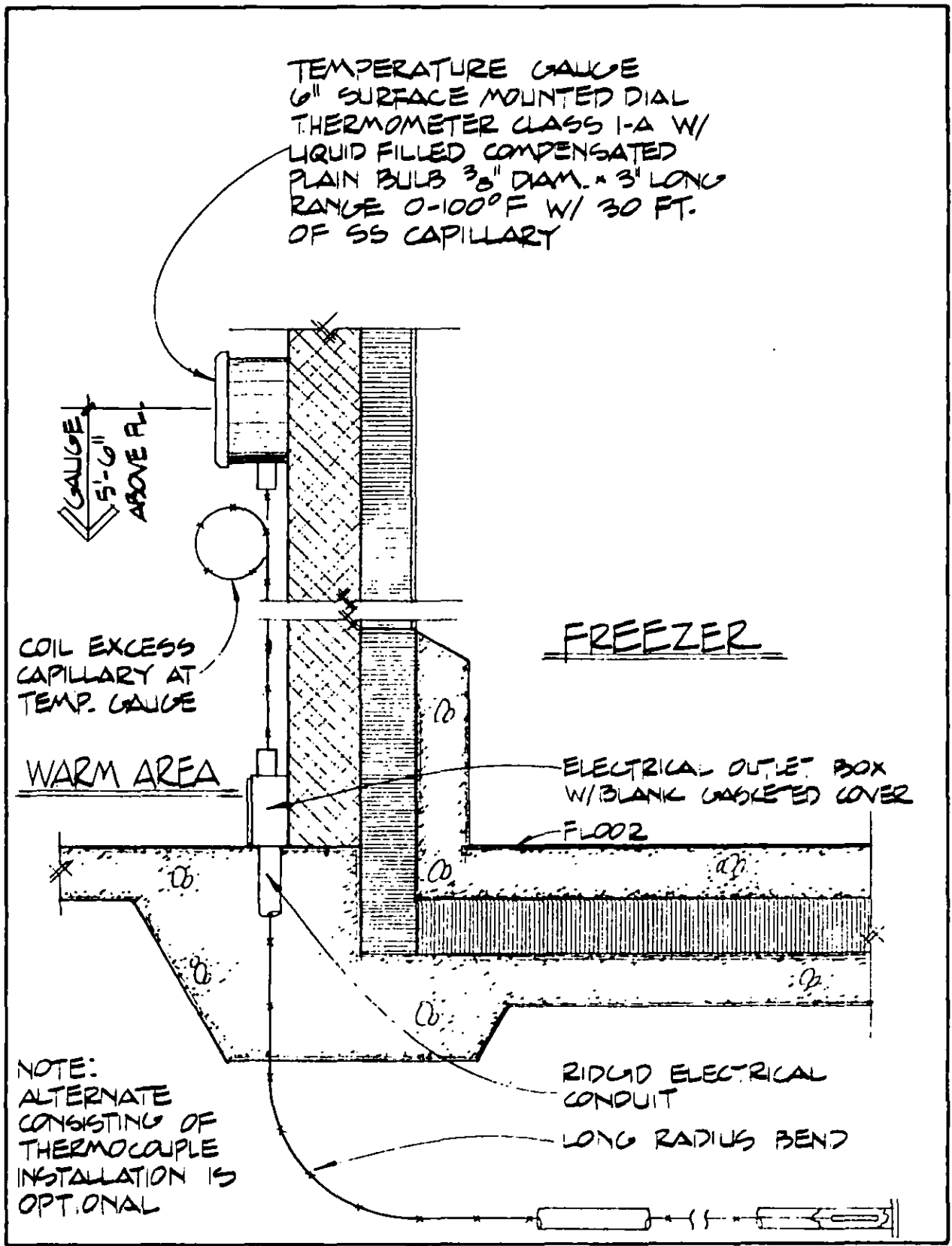
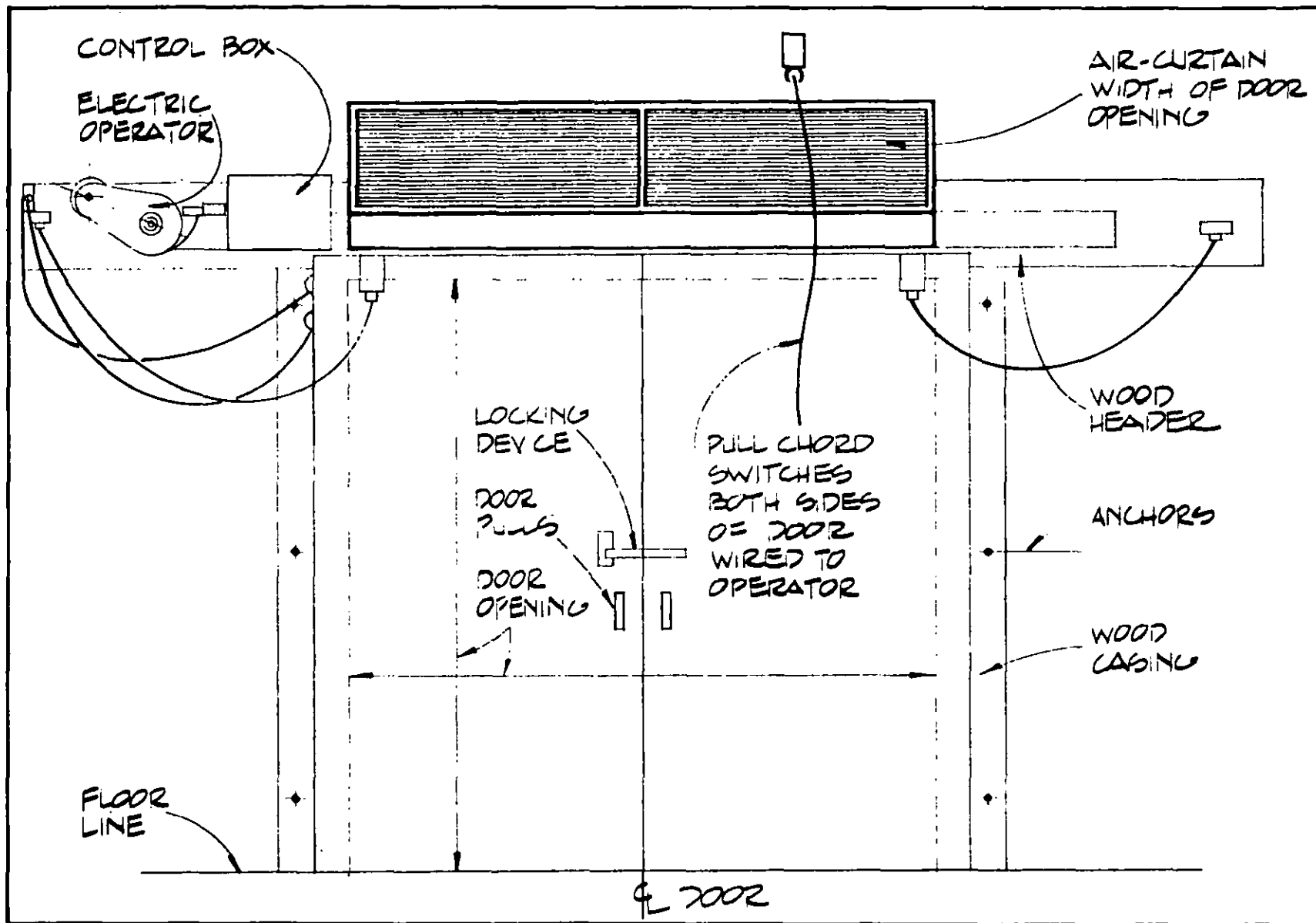

Figure A-18

Typical Ground Temperature Indicator Installation



118

MIL-HDBK-1032/2

Figure A-19

Typical Cold Storage Door With Air Curtain

MIL-HDBK-1032/2

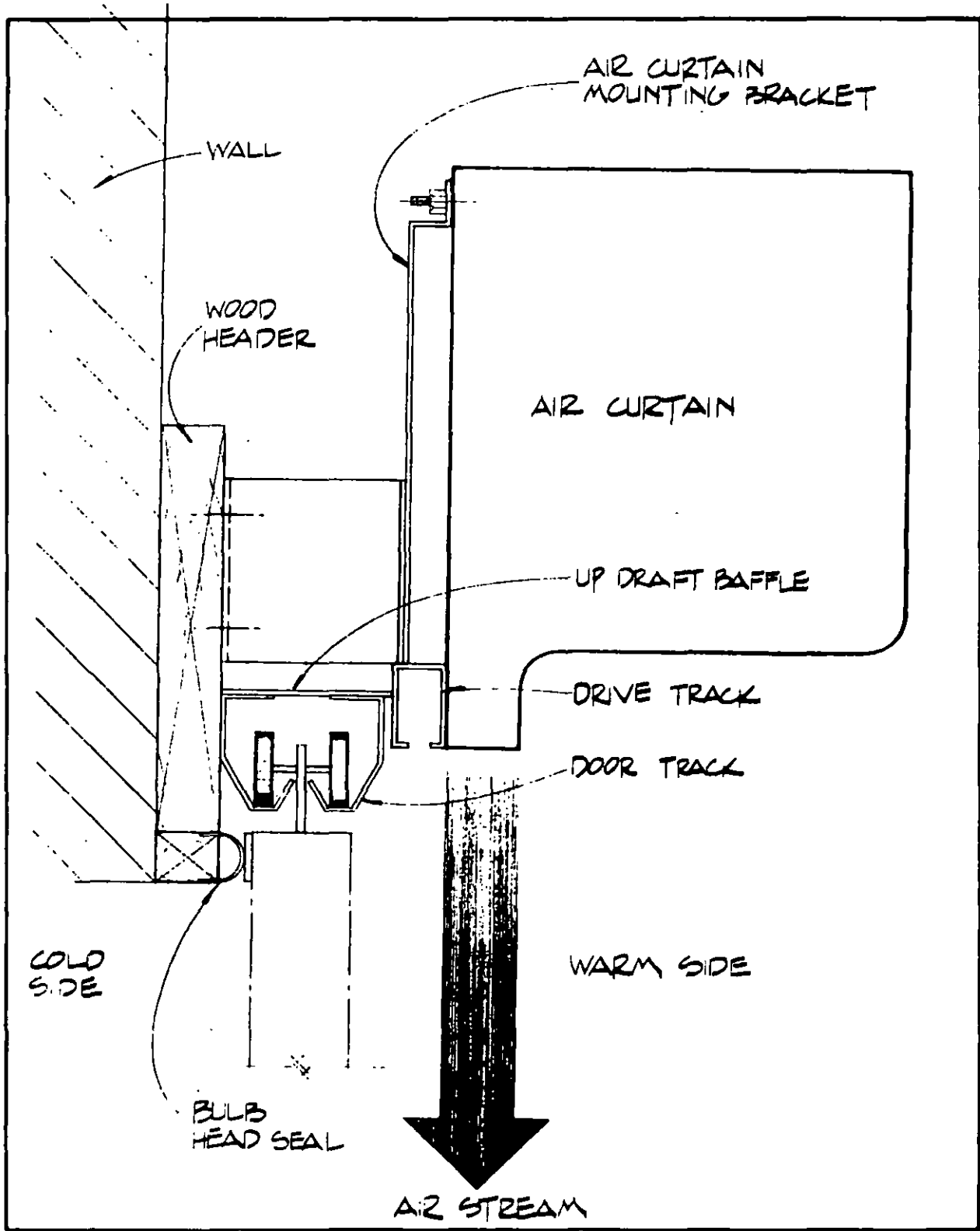

Figure A-20

Typical Air Curtain Detail At Door Head



MIL-HDBK-1032/2

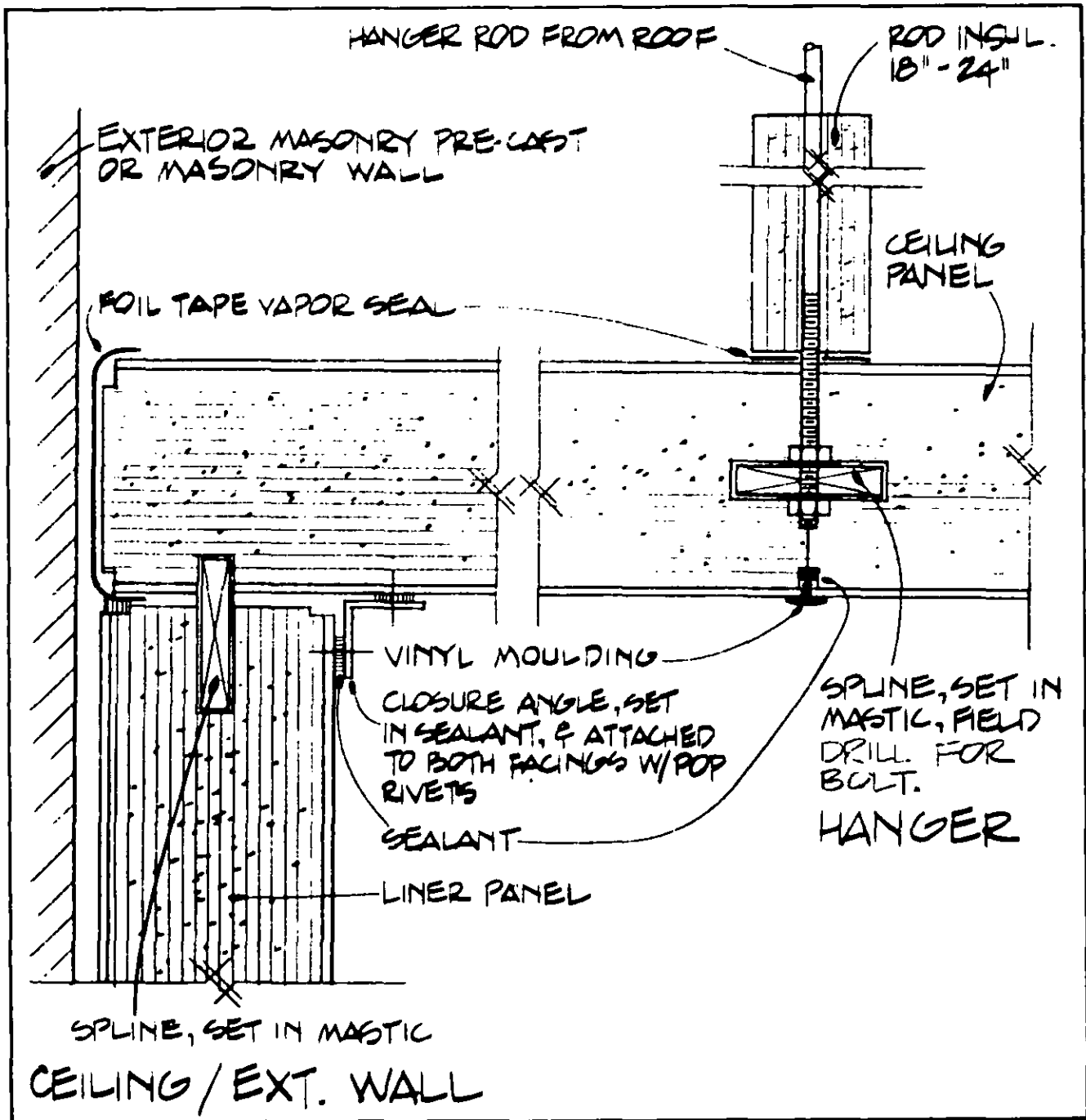

Figure A-21

Typical Suspended Ceiling Panel/Wall Panel Construction - 1

MIL-HDBK-1032/2

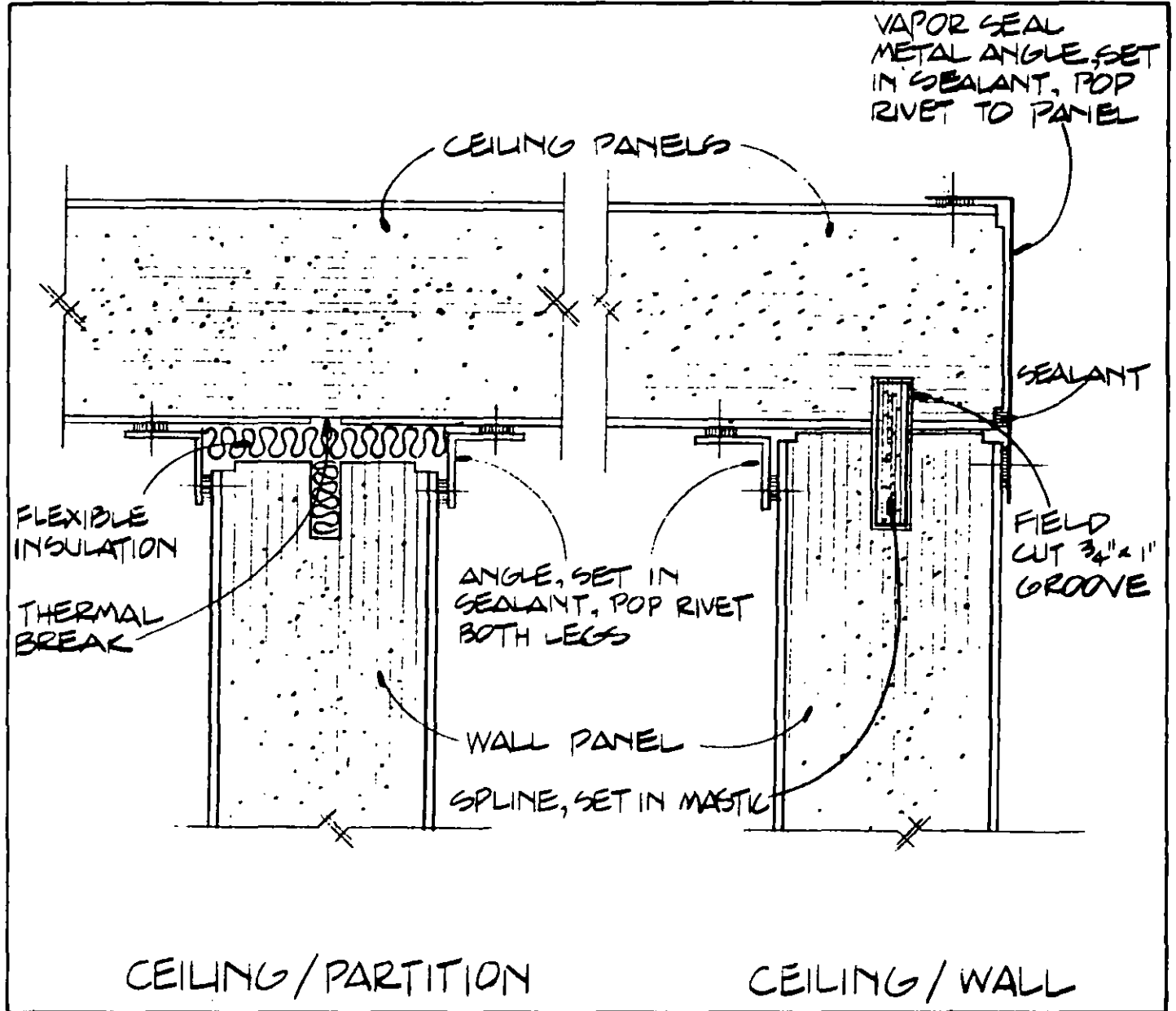

Figure A-22

Typical Suspended Ceiling Panel/Wall Panel Construction - 2

MIL-HDBK-1032/2

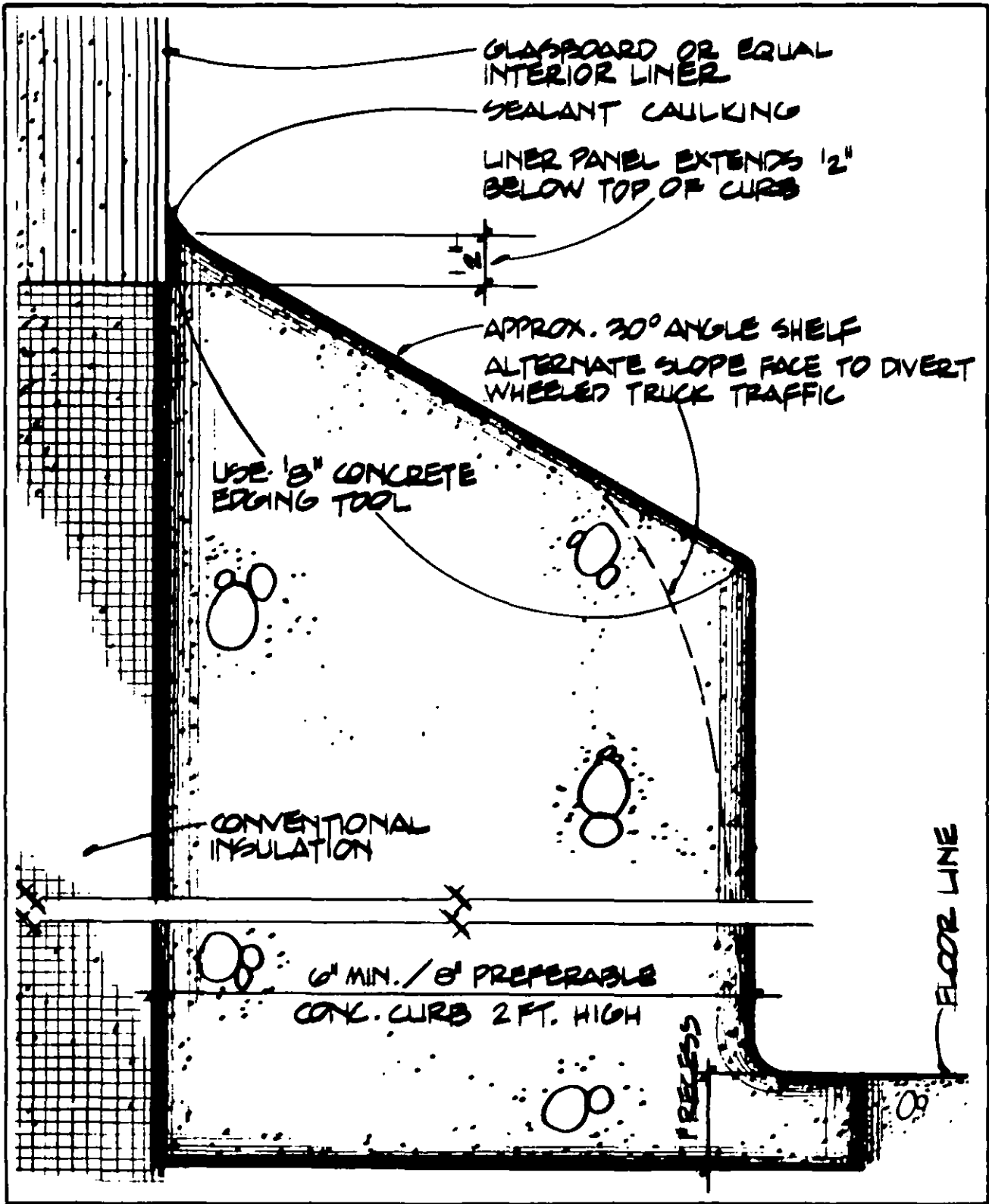

Figure A-23

Typical Wall Curb

MIL-HDBK-1032/2

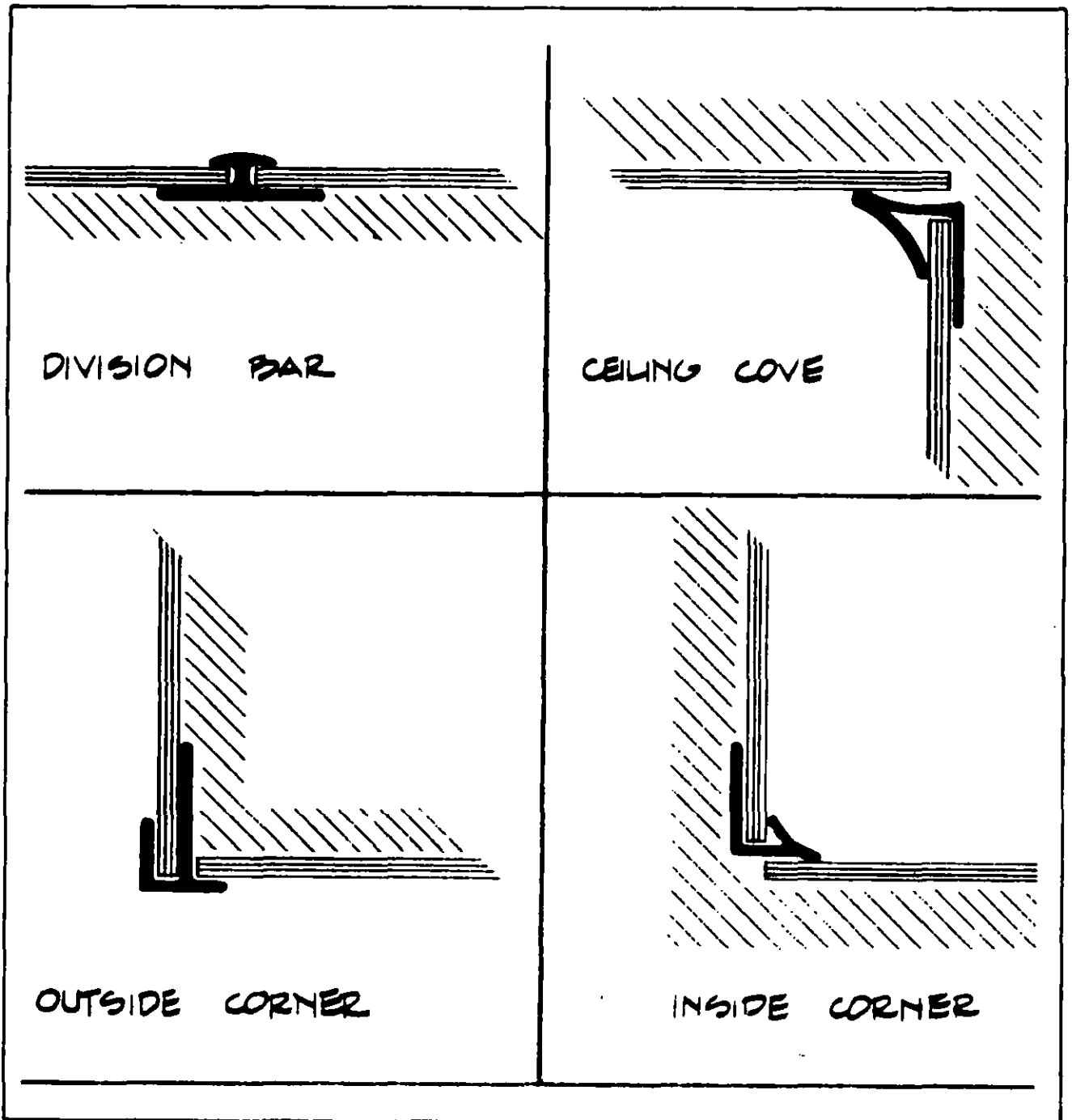

Figure A-24

Typical Vinyl Moldings For Use On Interior Wall Finishes

MIL-HDBK-1032/2

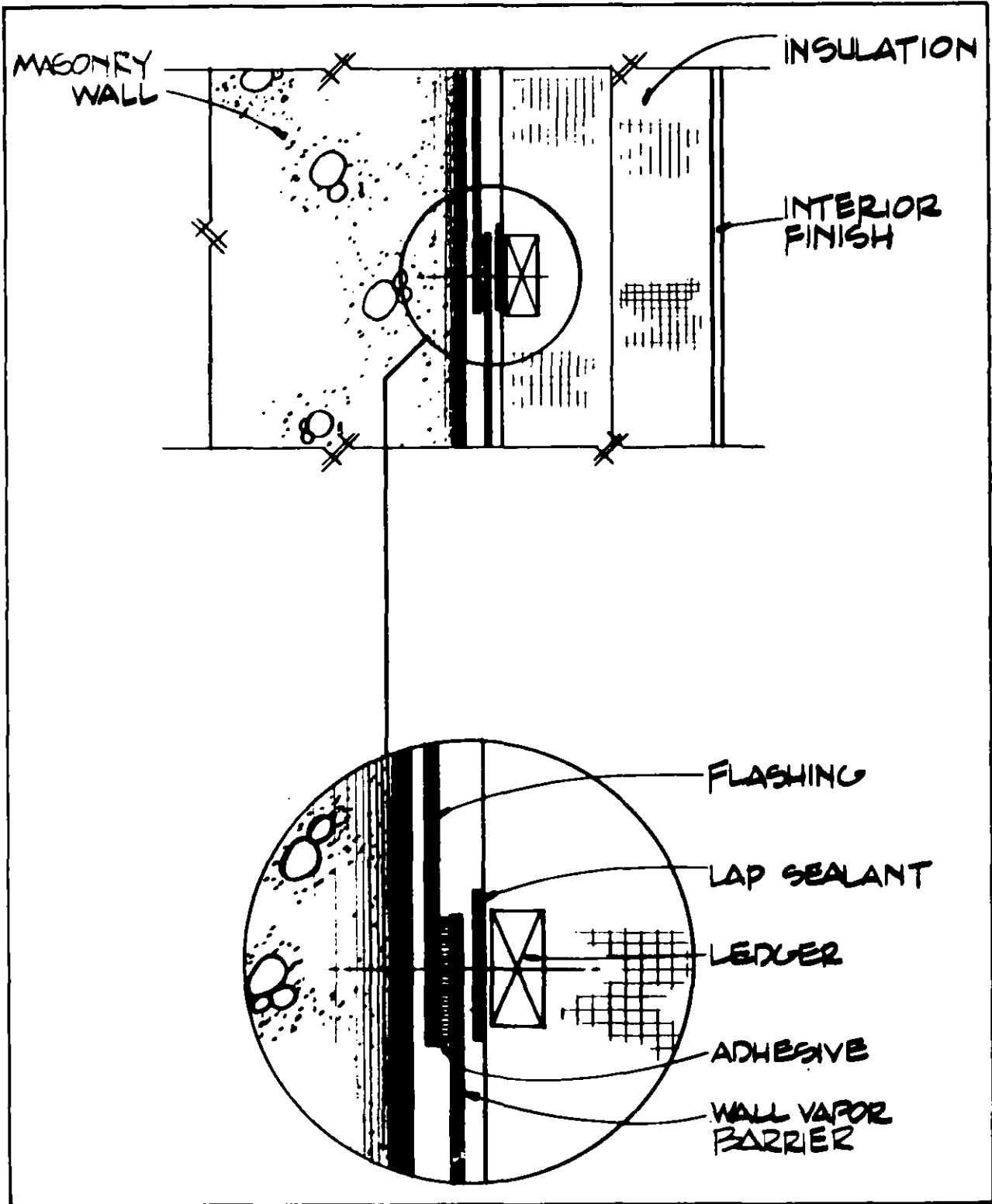

Figure A-25

Typical Fastener Detail And Vapor Barrier Penetration At  
Masonry Wall/Roof Juncture

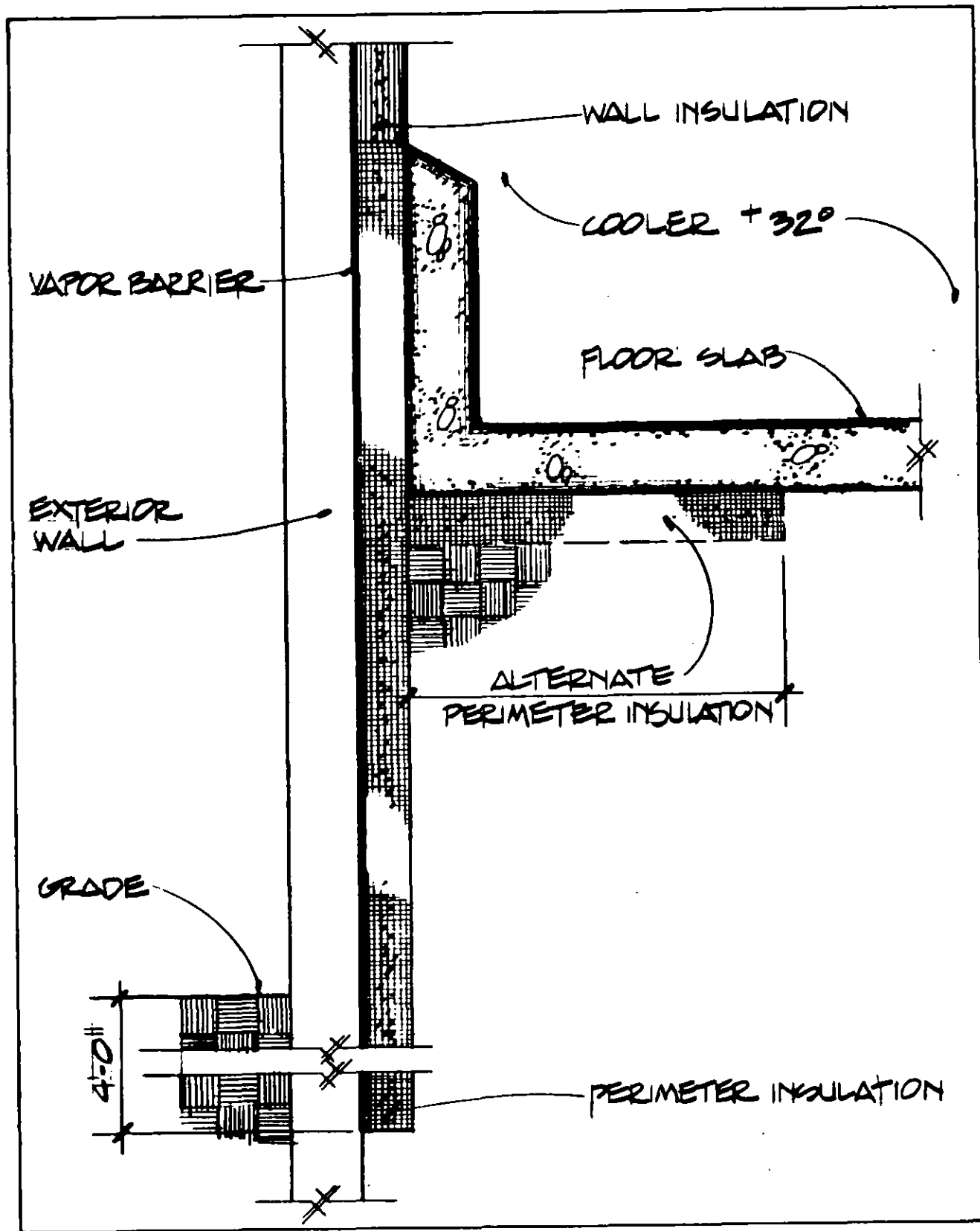

Figure A-26

Typical Cooler Floor Insulation

MIL-HDBK-1032/2

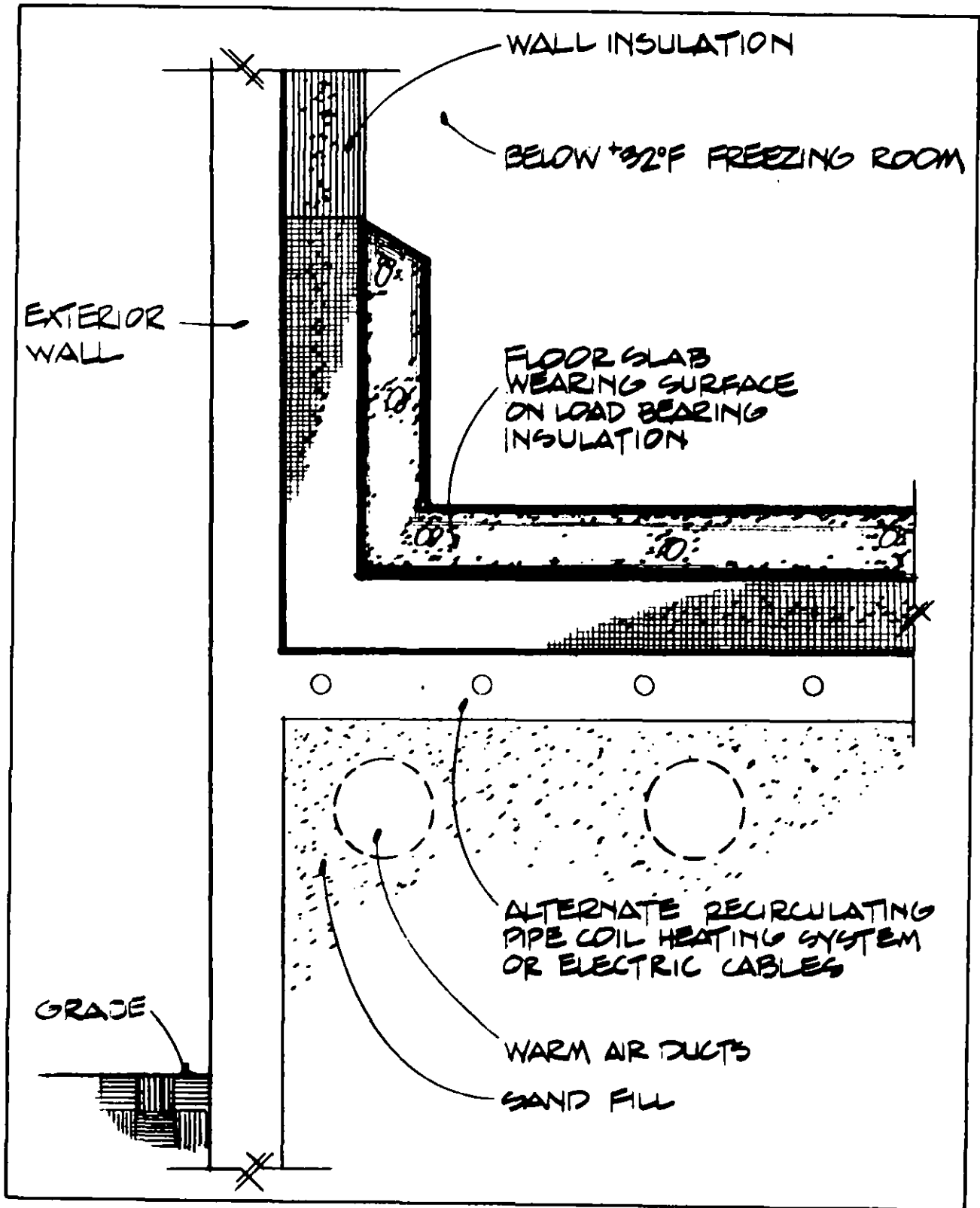

Figure A-27

Typical Freezer Floor Insulation

MIL-HDBK-1032/2

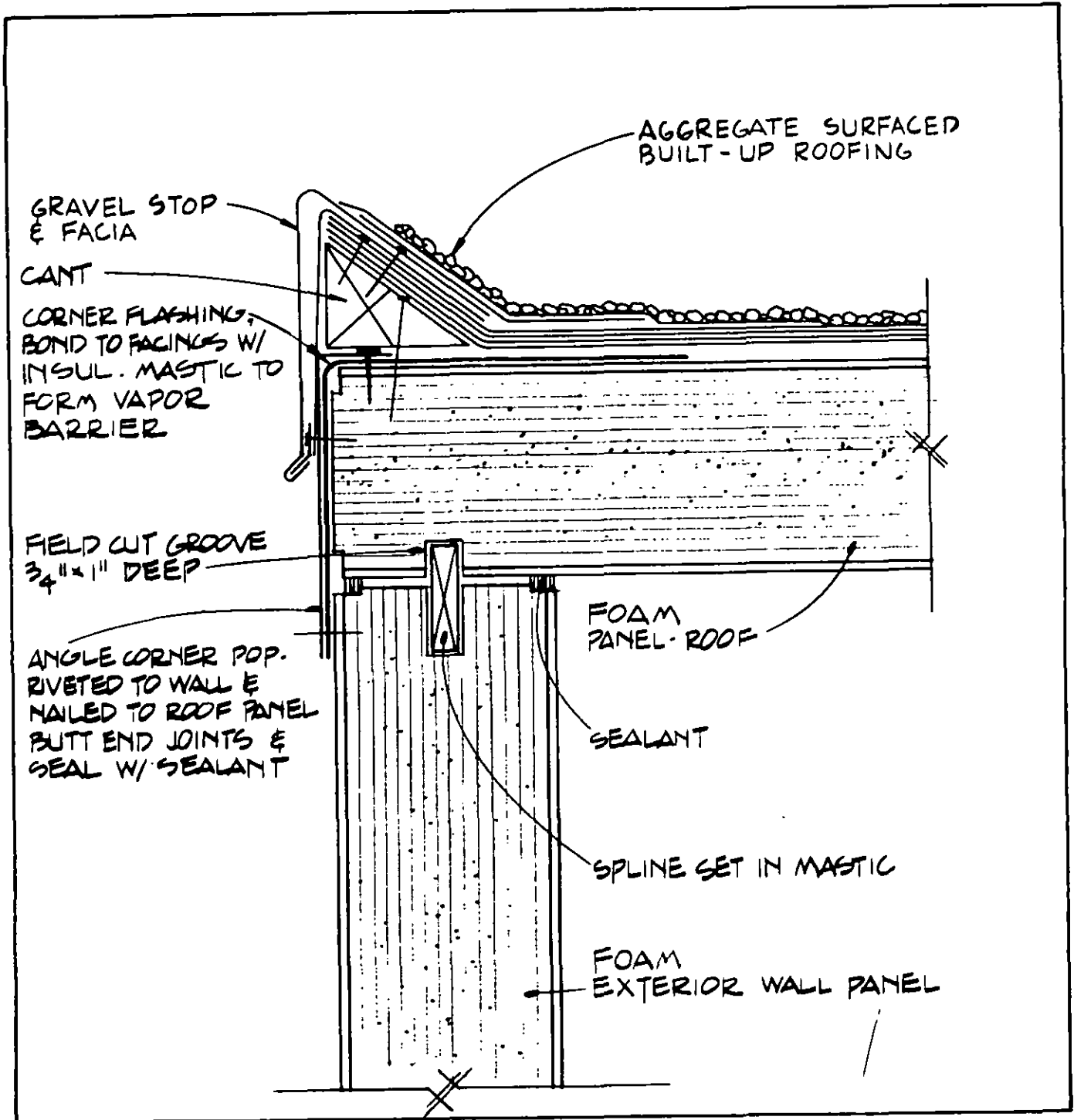

Figure A-28

Typical Exterior Wall, Panel/Roof Panel Construction



MIL-HDBK-1032/2

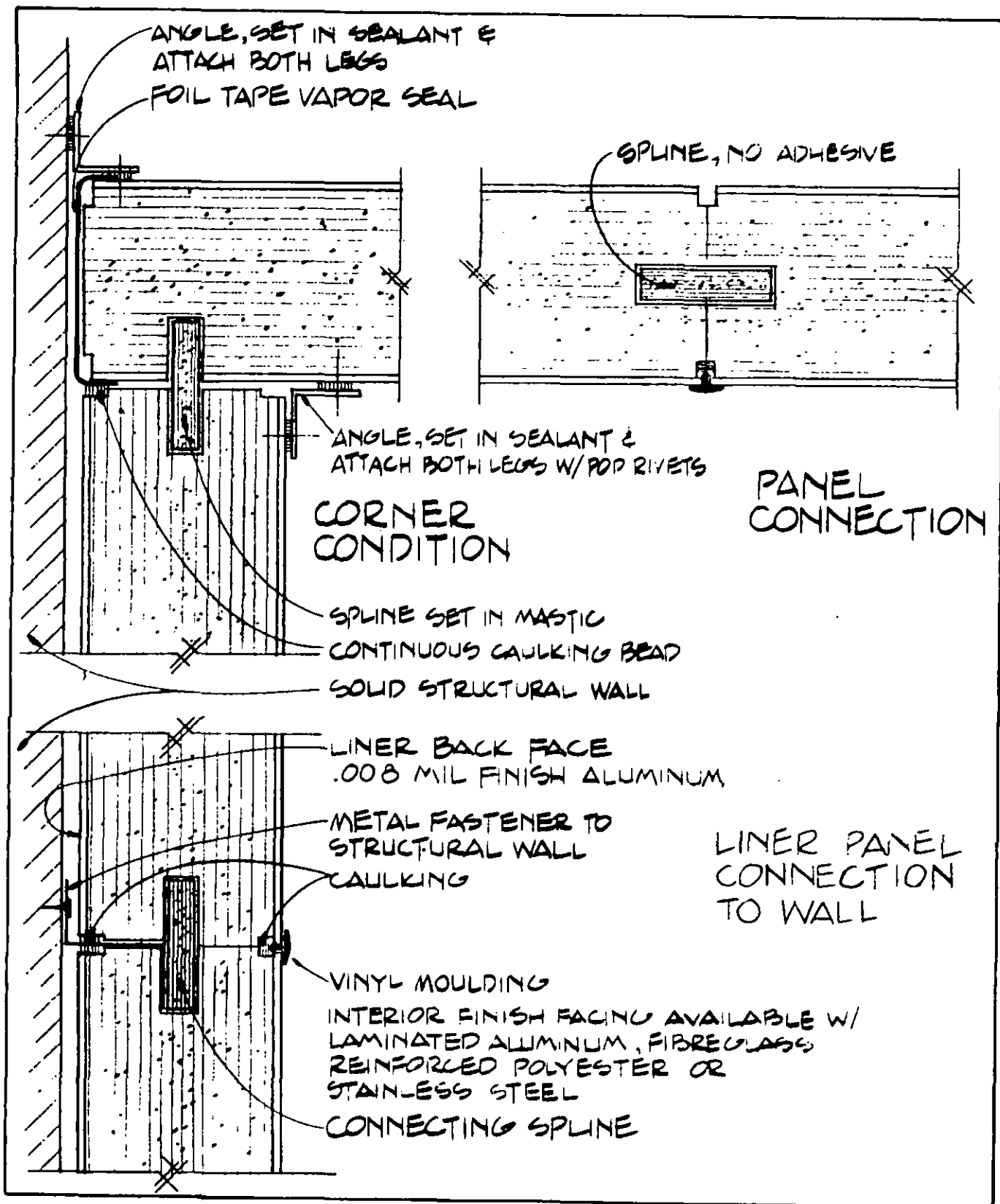

Figure A-29

Typical Wall Panel Construction - 1

MIL-HDBK-1032/2

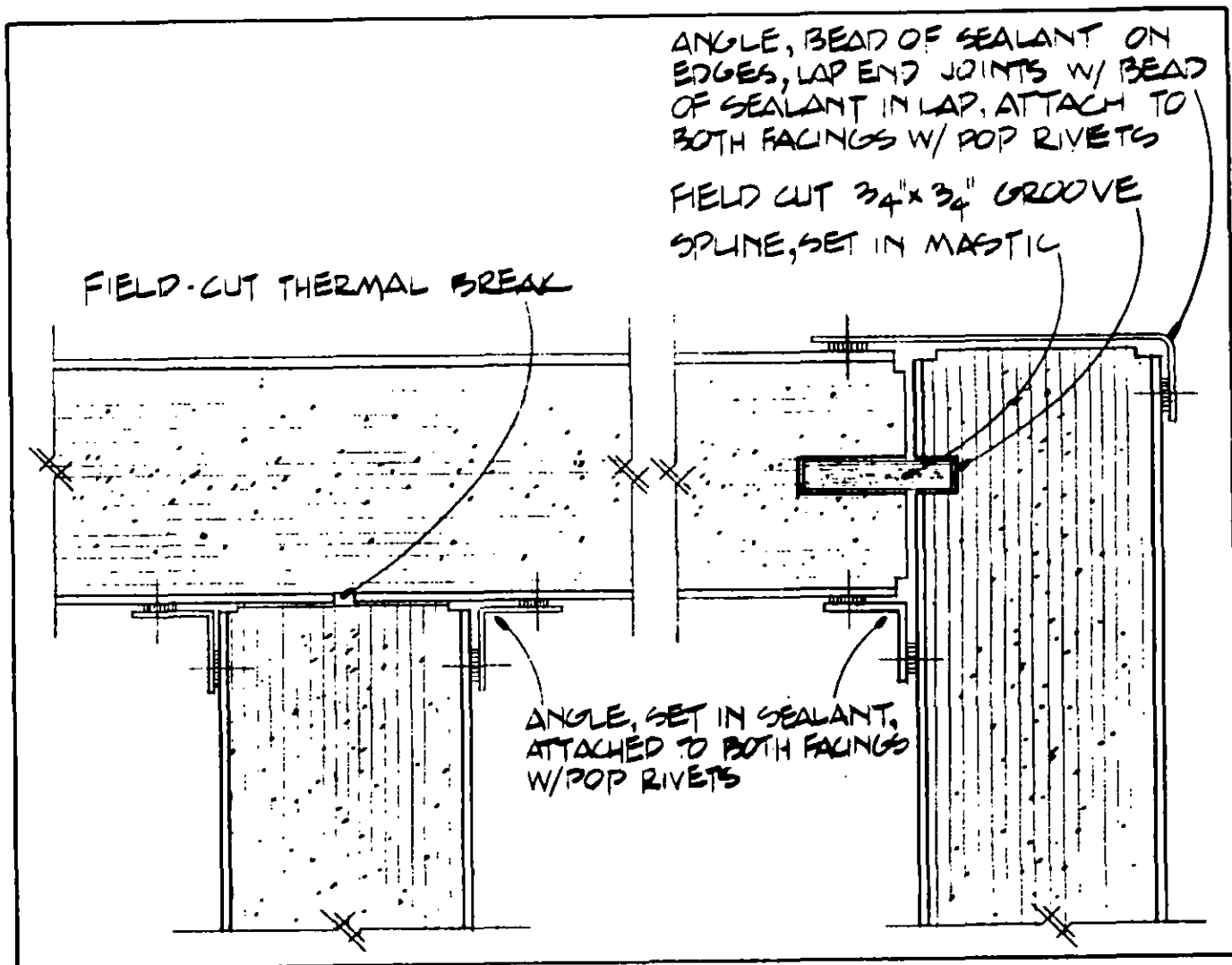

Figure A-30

Typical Wall Panel Construction - 2

MIL-HDBK-1032/2

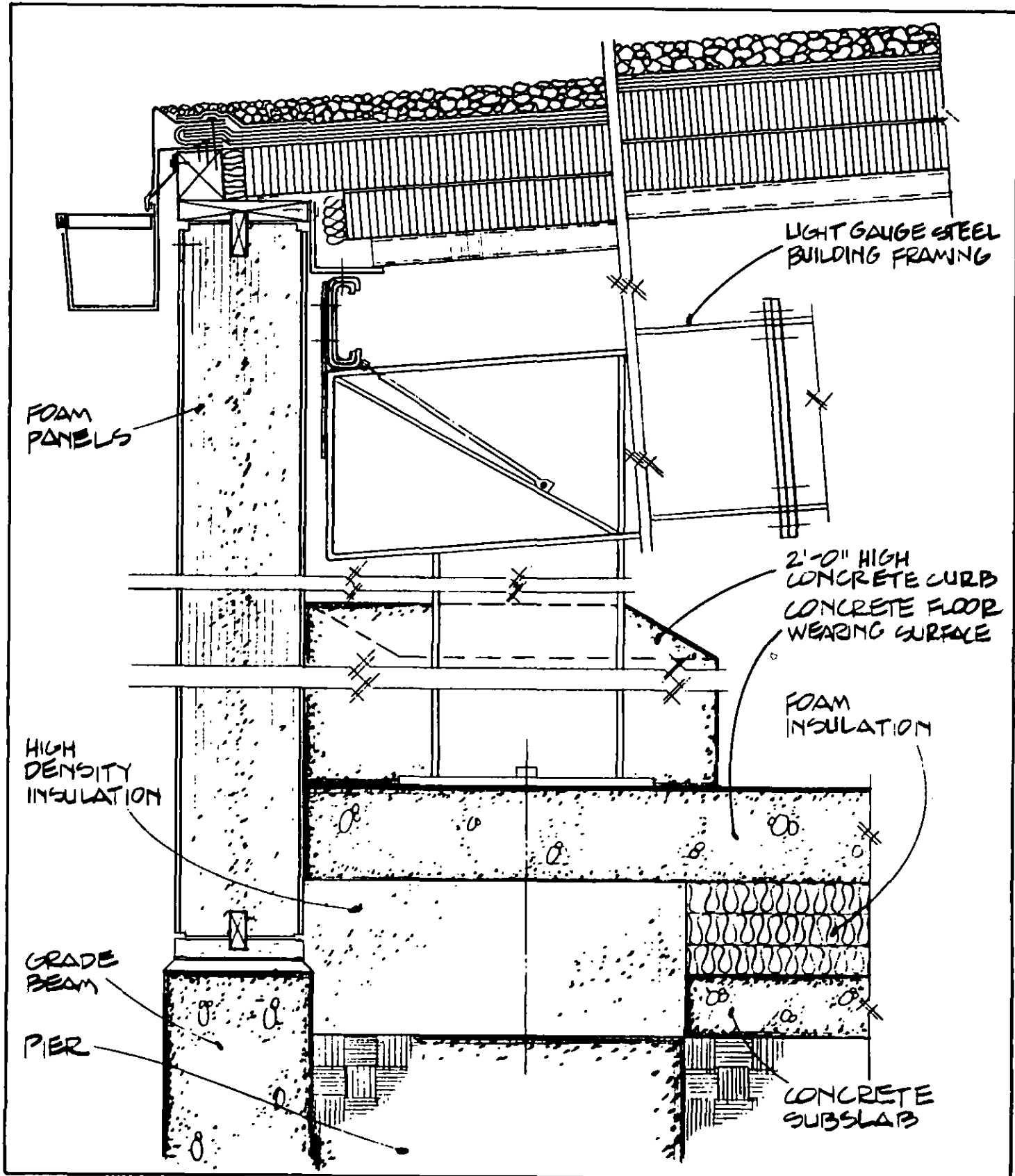

Figure A-31

Typical Pre-Fabricated Insulated Building

## MIL-HDBK-1032/2

## REFERENCES

American Concrete Institute (ACI) Publications, available from the American Concrete Institute, P.O. Box 19150, Redford Station, Detroit, MI 48219.

ACI 302.1R-80                      Manual of Concrete Practice, 1986 Edition  
Guide for Concrete Floor Slab Construction

American National Standards Institute (ANSI) Standards, available from the American National Standards Institute, 1430 Broadway, New York, NY 10018.

ANSI A117.1-1961                      Specification for Making Buildings and  
(R1980)                                  Facilities Accessible To, and Usable By,  
the Physically Handicapped

ANSI Z358.1-1981                      American National Standard for Emergency  
Eye Wash and Shower Equipment

Arctic and Subarctic Construction, TM 5-852 Series, available from U.S. Army AG Publications Center, 1655 Woodson Road, St. Louis, MO 63114.

ASHRAE Handbook, Fundamentals, available from American Society of Heating, Refrigeration, and Air Conditioning Engineers, Inc. (ASHRAE), 1791 Tulle Circle NE., Atlanta, GA 30329.

Code of Federal Regulations (CFR), available from the Government Printing Office, Superintendent of Documents, Washington, DC 20402.

29CFR Part 1910                      Occupational Safety and Health Standards

40CFR                                      Protection of Environment

49CFR Parts 171-177                      Hazardous Materials Regulations

Department of Defense (DOD) Manuals, available from Naval Publications and Forms Center, 5801 Tabor Avenue, Philadelphia, PA 19120.

DOD 4145.19-R-1                      Department of Defense Storage and Materials  
Handling Manual; September 1979

DOD 4270.1-M                              Department of Defense Construction Criteria  
Manual; February 1983

MIL-HDBK-1028/8                      Department of Defense Military Handbook, Pest  
Control Facilities; October 1984

MIL-HDBK-1008                              Department of Defense Military Handbook, Fire  
Protection for Facility Engineering; Design,  
and Construction, April 1985

## MIL-HDBK-1032/2

Department of the Navy, Office Chief of Naval Operations (OPNAVINST), available from Naval Publications and Forms Center, 5801 Tabor Avenue, Philadelphia, PA 19120.

|           |          |   |
|-----------|----------|---|
| OPNAVINST | 4100.5C  | Energy Management; July 1986                                    |
| OPNAVINST | 5090.1   | Environmental and Natural Resources Protection Manual; May 1983 |
| OPNAVINST | 5530.14A | Physical Security and Loss Prevention Manual; September 1985    |

Flood Plains Management, contained in 40CFR, Executive Order 11988, Part 6, Appendix A and DOD 4270.1-M, Chapter 4.

Handbook of Compressed Gases, available from the Compressed Gas Association, 1235 Jefferson Davis Highway, Arlington, VA 22202.

Industrial Ventilation Manual, available from American Conference of Governmental Industrial Hygienists, 6500 Glenway Avenue, Building D-5, Cincinnati, OH 45211

Materials Safety Data Sheet, Preparation and the Submission of, Federal Standard 313B. Copies can be obtained from the General Services Administration, 7th & D Streets, SW, Washington, DC 20407.

Military Standard System Safety Program Requirements, MIL-STD 882B, available from Naval Publications and Forms Center, 5801 Tabor Avenue, Philadelphia, PA 19120.

National Fire Protection Association (NFPA) Standards, available from the National Fire Protection Association, Batterymarch Park, Quincy, MA 02269.

|          |  |
|----------|--|
| NFPA 10  | Portable Fire Extinguishers; 1984                                      |
| NFPA 11  | Low Expansion Foam and Combined Agent Systems; 1983                    |
| NFPA 12  | Carbon Dioxide Extinguishing Systems; 1985                             |
| NFPA 12A | Halon 1301 Fire Extinguishing Systems; 1985                            |
| NFPA 13  | Sprinkler Systems, Installation; 1985                                  |
| NFPA 14  | Standpipe and Hose Systems, Installation of; 1983                      |
| NFPA 16  | Deluge Foam-Water Sprinkler Systems and Foam-Water Spray Systems; 1980 |
| NFPA 17  | Dry Chemical Extinguishing Systems; 1984                               |
| NFPA 30  | Flammable and Combustible Liquids, Code; 1984                          |

## MIL-HDBK-1032/2

|           |  |
|-----------|--|
| NFPA 43A  | Oxidizing Materials, Liquid and Solid Storage of; 1980   |
| NFPA 43C  | Oxidizing Materials, Gaseous, Storage; 1980  |
| NFPA 43D  | Pesticides in Portable Containers; 1980  |
| NFPA 49   | Chemicals Data, Hazardous; 1975  |
| NFPA 68   | Explosion Venting; 1978  |
| NFPA 70   | Electrical Code, National; 1984  |
| NFPA 72A  | Local Protection Signalling Systems; 1985  |
| NFPA 72D  | Proprietary Protection Signalling Systems; 1979  |
| NFPA 72E  | Automatic Fire Detectors; 1984   |
| NFPA 78   | Lightning Protection Code; 1983  |
| NFPA 80   | Fire Doors and Windows; 1983   |
| NFPA 101  | Life Safety Code; 1985   |
| NFPA 204M | Smoke and Heat Venting; 1985   |
| NFPA 220  | Building Construction, Standard Types of; 1985   |
| NFPA 231  | Storage, General Indoor; 1985  |
| NFPA 231C | Rack Storage of Materials; 1980  |
| NFPA 231D | Rubber Tires, Storage of; 1980   |
| NFPA 321  | Flammable and Combustible Liquids, Classification; 1982  |
| NFPA 325M | Flammable Liquids, Gases, and Volatile Solids, Fire Hazard Properties of; 1984                   |
| NFPA 490  | Ammonium Nitrate, Storage of; 1980   |
| NFPA 491M | Chemical Reactions, Hazardous; 1975  |
| NFPA 497M | Classification of Gases, Vapors, and Dusts for Electrical Equipment in Hazardous Locations; 1983 |
| NFPA 704  | Fire Hazards of Materials, Identification; 1985  |

Naval Facilities Engineering Command (NAVFACENGCOM) Manuals. Design Manuals (DM) and Publications (P) may be obtained from the Naval Publications and Forms Center, 5801 Tabor Avenue, Philadelphia, PA 19120.

DM-2.01

Structural Engineering, General Requirements; May 1980

## MIL-HDBK-1032/2

|                  |   |
|------------------|---|
| DM-2.04          | Structural Engineering, Concrete Structures; May 1980   |
| DM-3.01          | Plumbing Systems; May 1986  |
| DM-3.03          | Heating, Ventilating, Air Conditioning, and Dehumidifying Systems; January 1987                       |
| DM-3.04          | Refrigeration Systems for Cold Storage; August 1986   |
| DM-3.05          | Compressed Air and Vacuum Systems; March 1983   |
| DM-4.01          | Electrical Engineering, Design Considerations; March 1983   |
| DM-4.04          | Electrical Utilization Systems; April 1982  |
| DM-5.04          | Pavements; March 1986   |
| DM-5.05          | General Provisions and Geometric Design for Roads, Streets, Walks, and Open Storage Areas; April 1977 |
| DM-5.06          | Trackage; November 1981   |
| DM-5.07          | Water Supply Systems; October 1979  |
| DM-5.08          | Domestic Wastewater Control; December 1986  |
| DM-5.12          | Fencing, Gates, and Guard Towers; April 1980  |
| MIL-HDBK-1005/13 | Hazardous Waste Storage Facilities; April 1987  |
| DM-7.01          | Soil Mechanics; September 1986  |
| DM-7.02          | Foundations and Earth Structures; September 1986  |
| MIL-HDBK-1011/1  | Tropical Engineering; March 1980  |
| MIL-HDBK-1013/1  | Physical Security; April 1987   |
| DM-22            | Petroleum Fuel Facilities; August 1982  |
| DM-25.06         | General Criteria for Waterfront Construction; July 1981   |
| DM-28.04         | General Maintenance Facilities; September 1984  |
| DM-38.01         | Weight Handling Equipment; October 1986   |
| P-80             | Facility Planning Criteria for Navy and Marine Corps Shore Installations;                             |
| P-309            | Color for Naval Shore Facilities; September 1981  |

## MIL-HDBK-1032/2

- P-355 Seismic Design for Buildings; February 1982
- P-442 Economic Analysis Handbook; July 1980

The following NAVFACENGCOM Publications may be obtained directly from the individual Engineering Field Division (EFD) offices.

- P-34 Engineering and Design Criteria for Navy Facilities
- P-272 Definitive Designs for Naval Shore Facilities (1404208 thru 1404214 and 1404516 thru 1404520)

Naval Facilities Engineering Command Instructions (NAVFACINST), are available from the Naval Publications and Forms Center, 5801 Tabor Avenue, Philadelphia, PA 19120.

Naval Supply Systems Command (NAVSUP) Publications, available from Naval Publications and Forms Center, 5801 Tabor Avenue, Philadelphia, PA 19120.

- NAVSUP PUB-502 Preservation and Packing; August 1982
- NAVSUP PUB-503 Packing; June 1977
- NAVSUP PUB-529 Warehouse Modernization and Layout Planning Guide; March 1985
- NAVSUPINST 4000.34B Radioactive Commodities in the DOD Supply Systems; April 1985
- NAVSUPINST 4440.128B Storage and Handling of Compressed Gases and Gas Cylinders; September 1971
- NAVSUPINST 4450.21A Storage and Warehousing Facilities and Services; June 1978
- NAVSUPINST 5100.27 Navy Hazardous Material Control Program; August 1985

Real Property Facilities, Marine Corps Order MCO, 11000.8 (Environmental Management), available from Headquarters, United States Marine Corps, Code HQSP, Washington, DC 20380-0001.

Removal and Disposal of Asbestos Material, NAVFAC Guide Specification NFGS-02075, available from Naval Publications and Forms Center, 5801 Tabor Avenue, Philadelphia, PA 19120.

- NAVFACINST 11010.44D Shore Facilities Planning Manual; November 1979

Test for Penetration for Bituminous Materials, ASTM D-5-78 (1978); available from American Society for Testing and Materials (ASTM), 1916 Race Street, Philadelphia, PA 19103.



MIL-HDBK-1032/2

CUSTODIAN  
NAVY - YD

PREPARING ACTIVITY  
NAVY - YD

PROJECT NO.  
FACR-0176

**INSTRUCTIONS:** In a continuing effort to make our standardization documents better, the DoD provides this form for use in submitting comments and suggestions for improvements. All users of military standardization documents are invited to provide suggestions. This form may be detached, folded along the lines indicated, taped along the loose edge (*DO NOT STAPLE*), and mailed. In block 5, be as specific as possible about particular problem areas such as wording which required interpretation, was too rigid, restrictive, loose, ambiguous, or was incompatible, and give proposed wording changes which would alleviate the problems. Enter in block 6 any remarks not related to a specific paragraph of the document. If block 7 is filled out, an acknowledgement will be mailed to you within 30 days to let you know that your comments were received and are being considered.

**NOTE:** This form may not be used to request copies of documents, nor to request waivers, deviations, or clarification of specification requirements on current contracts. Comments submitted on this form do not constitute or imply authorization to waive any portion of the referenced document(s) or to amend contractual requirements.

(Fold along this line)

(Fold along this line)

DEPARTMENT OF THE NAVY  
NAVAL FACILITIES ENGINEERING COMMAND  
200 Stovall Street  
Alexandria, VA 22332-2300



NO POSTAGE  
NECESSARY  
IF MAILED  
IN THE  
UNITED STATES

OFFICIAL BUSINESS  
PENALTY FOR PRIVATE USE \$300

**BUSINESS REPLY MAIL**  
FIRST CLASS PERMIT NO. 12503 WASHINGTON D. C.  
POSTAGE WILL BE PAID BY THE DEPARTMENT OF THE NAVY

COMMANDING OFFICER  
Chesapeake Division  
Naval Facilities Engineering  
Command  
Washington Navy Yard  
Washington, DC 20374

